

FCC TEST REPORT
FOR
GUANGZHOU ADS AUDIO SCIENCE & TECHNOLOGY CO., LTD.
WIRELESS MICROPHONE
Model No.: W-1606D
Additional Model No.: Please refer to page 7

Prepared for : GUANGZHOU ADS AUDIO SCIENCE & TECHNOLOGY CO., LTD.
Address : SHIMA INDUSTRIAL PARK, XINSHI TOWN, BAIYUN DISTRICT,
GUANGZHOU, China

Prepared by : Shenzhen LCS Compliance Testing Laboratory Ltd.
Address : 1/F., Xingyuan Industrial Park, Tongda Road, Bao'an Avenue, Bao'an
District, Shenzhen, Guangdong, China

Tel : (+86)755-82591330
Fax : (+86)755-82591332
Web : www.LCS-cert.com
Mail : webmaster@LCS-cert.com

Date of receipt of test sample : June 06, 2016
Number of tested samples : 1
Serial number : Prototype
ate of Test : June 06, 2016~August 18, 2016
Date of Report : August 18, 2016

FCC TEST REPORT

FCC CFR 47 PART 74H (74.861): 2015

Report Reference No. : LCS1606060517E

Date of Issue : August 18, 2016

Testing Laboratory Name : Shenzhen LCS Compliance Testing Laboratory Ltd.

Address : 1/F., Xingyuan Industrial Park, Tongda Road, Bao'an Avenue, Bao'an District, Shenzhen, Guangdong, China

Testing Location/ Procedure : Full application of Harmonized standards ■
Partial application of Harmonized standards □
Other standard testing method □

Applicant's Name : GUANGZHOU ADS AUDIO SCIENCE & TECHNOLOGY CO., LTD.

Address : SHIMA INDUSTRIAL PARK, XINSHI TOWN, BAIYUN DISTRICT, GUANGZHOU, China

Test Specification

Standard : FCC CFR 47 PART 74H (74.861): 2015

Test Report Form No. : LCSEMC-1.0

TRF Originator : Shenzhen LCS Compliance Testing Laboratory Ltd.

Master TRF : Dated 2011-03

Shenzhen LCS Compliance Testing Laboratory Ltd. All rights reserved.

This publication may be reproduced in whole or in part for non-commercial purposes as long as the Shenzhen LCS Compliance Testing Laboratory Ltd. is acknowledged as copyright owner and source of the material. Shenzhen LCS Compliance Testing Laboratory Ltd. takes no responsibility for and will not assume liability for damages resulting from the reader's interpretation of the reproduced material due to its placement and context.

Test Item Description : WIRELESS MICROPHONE

Trade Mark : 1)■■■a/d/s/, 2)QFX, 3) PRECISION

Model/ Type reference : W-1606D

Ratings : DC 3.0V by 2*AA battery

Result : Positive

Compiled by:

Jacky Li

Jacky Li/ File administrators

Supervised by:

Glin Lu

Glin Lu/ Technique principal

Approved by:

Gavin Liang

Gavin Liang/ Manager

FCC -- TEST REPORT

Test Report No. : LCS1606060517E	<u>August 18, 2016</u> Date of issue
--	---

Type / Model.....	: W-1606D
EUT.....	: WIRELESS MICROPHONE
Applicant.....	: GUANGZHOU ADS AUDIO SCIENCE & TECHNOLOGY CO., LTD.
Address.....	: SHIMA INDUSTRIAL PARK, XINSHI TOWN, BAIYUN DISTRICT, GUANGZHOU, China
Telephone.....	: 020-36409886
Fax.....	: 020-36409999
Manufacturer.....	: GUANGZHOU ADS AUDIO SCIENCE & TECHNOLOGY CO., LTD.
Address.....	: SHIMA INDUSTRIAL PARK, XINSHI TOWN, BAIYUN DISTRICT, GUANGZHOU, China
Telephone.....	: 020-36409886
Fax.....	: 020-36409999
Factory.....	: GUANGZHOU ADS AUDIO SCIENCE & TECHNOLOGY CO., LTD.
Address.....	: SHIMA INDUSTRIAL PARK, XINSHI TOWN, BAIYUN DISTRICT, GUANGZHOU, China
Telephone.....	: 020-36409886
Fax.....	: 020-36409999

Test Result	Positive
--------------------	-----------------

The test report merely corresponds to the test sample.
It is not permitted to copy extracts of these test result without the written permission of the test laboratory.

Revision History

Revision	Issue Date	Revisions	Revised By
00	2016-08-18	Initial Issue	Gavin Liang

TABLE OF CONTENTS

Description	Page
1. GENERAL INFORMATION	7
1.1 Description of Device (EUT)	7
1.2 Support equipment List.....	7
1.3 External I/O Cable	7
1.4 Description of Test Facility	8
1.5 Statement of The Measurement Uncertainty	8
1.6 Measurement Uncertainty	8
1.7 Description Of Test Modes	8
2. TEST METHODOLOGY	9
2.1 EUT Configuration.....	9
2.2 EUT Exercise	9
3. SYSTEM TEST CONFIGURATION	10
3.1 Justification.....	10
3.2 EUT Exercise Software	10
3.3 Special Accessories.....	10
3.4 Block Diagram/Schematics	10
3.5 Equipment Modifications	10
3.6 Test Setup	10
4. SUMMARY OF TEST RESULTS.....	11
5. SUMMARY OF TEST EQUIPMENT	12
6. MAXMIUM OUTPUT POWER.....	13
6.1 Limit	13
6.2 Test Procedure	13
6.3 Test Configuration.....	14
6.4 Test Results	14
7. MODULATION CHARACTERISTICS.....	15
7.1 Limit	15
7.2 Test Procedure	15
7.3 Test Configuration.....	15
7.4 Test Results	16
8. FREQUENCY TOLERANCE.....	20
8.1 Limit	20
8.2 Test Configuration.....	20
8.3 Test Procedure	20
8.4 Test Results	21
9. OPERATING BANDWIDTH	22
9.1 Limit	22
9.2 Test Configuration.....	22
9.3 Test Procedure	22
9.4 Test Results	23
10. UNWANTED RADIATION	24
10.1 Limit.....	24
10.2 Test Configuration	24
10.3 Test Procedure	25
10.4 Test Results of Conducted Emissions Mask	26
10.5 Test Results of Radiated Emissions	27

11. NECESSARY BANDWIDTH 28
 11.1 Limit28
 11.2 Test Configuration28
 11.3 Instruments Setting28
 11.4 Test Procedures29
 11.5 Test Results29
12. TEST SETUP PHOTOS OF THE EUT 31
13. EXTERNAL PHOTOS OF THE EUT 31
14. INTERNAL PHOTOS OF THE EUT..... 31

1. GENERAL INFORMATION

1.1 Description of Device (EUT)

EUT	: WIRELESS MICROPHONE
Model No.	: W-1606D, W-1506D, W-1529D, W-1129D, W-1629D, W-1229D
Model Declaration	: PCB board, structure and internal of these model(s) are the same, So no additional models were tested
Test Model No.:	: W-1606D
Frequency Range	: 185.15~202.20MHz
Channel Number	: 2 channels
Channel frequency	: 185.15MHz, 202.20MHz
Modulation Type	: FM
Emission Type	: F3E
Antenna Gain	: Integral antenna, 0 dBi (Max.)
Input Voltage	: DC 3.0V by 2*AA battery
Voltage of End Point	: DC 2.5V

1.2 Support equipment List

Manufacturer	Description	Model	Serial Number	Certificate
--	--	--	--	-

1.3 External I/O Cable

I/O Port Description	Quantity	Cable
--	--	--

1.4 Description of Test Facility

Site Description
EMC Lab.

: CNAS Registration Number. is L4595.
 FCC Registration Number. is 899208.
 Industry Canada Registration Number. is 9642A-1.
 VCCI Registration Number. is C-4260 and R-3804.
 ESMD Registration Number. is ARCB0108.
 UL Registration Number. is 100571-492.
 TUV SUD Registration Number. is SCN1081.
 TUV RH Registration Number. is UA 50296516-001

The test site is constructed and calibrated to meet the FCC requirements in documents ANSI C63.4:2014.

1.5 Statement of the Measurement Uncertainty

The data and results referenced in this document are true and accurate. The reader is cautioned that there may be errors within the calibration limits of the equipment and facilities. The measurement uncertainty was calculated for all measurements listed in this test report acc. To CISPR 16 – 4 “Specification for radio disturbance and immunity measuring apparatus and methods – Part 4: Uncertainty in EMC Measurements” and is documented in the LCS quality system acc. To DIN EN ISO/IEC 17025. Furthermore, component and process variability of devices similar to that tested may result in additional deviation. The manufacturer has the sole responsibility of continued compliance of the device.

1.6 Measurement Uncertainty

Test Item	Frequency Range	Uncertainty	Note
Radiation Uncertainty	9KHz~30MHz	3.10dB	(1)
	30MHz~200MHz	2.96dB	(1)
	200MHz~1000MHz	3.10dB	(1)
	1GHz~26.5GHz	3.80dB	(1)
	26.5GHz~40GHz	3.90dB	(1)
Conduction Uncertainty	150kHz~30MHz	1.63dB	(1)
Power disturbance	30MHz~300MHz	1.60dB	(1)

(1). This uncertainty represents an expanded uncertainty expressed at approximately the 95% confidence level using a coverage factor of k=2.

1.7 Description of Test Modes

WIRELESS MICROPHONE operates in the licensed Band at 185.15~202.20MHz. The EUT works in the X-axis, Y-axis and Z-axis. The following operating modes were applied for the related test items. All test modes were tested, only the result of the worst case was recorded in the report.

Mode of Operations	Frequency Range (MHz)
FM	185.15
	202.20
Radiated Emission	
Test Mode	Continuous Transmit

2. TEST METHODOLOGY

The tests documented in this report were performed in accordance with ANSI C63.4-2014, ANSI TIA/EIA 603, FCC CFR 47 2.1046, 2.1047, 2.1049, 2.1051, 2.1053, 2.1055, 2.1057, 74.861.

2.1 EUT Configuration

The EUT configuration for testing is installed on RF field strength measurement to meet the Commissions requirement and operating in a manner that intends to maximize its emission characteristics in a continuous normal application.

2.2 EUT Exercise

The EUT was operated in the engineering mode to fix the TX frequency that was for the purpose of the measurements.

According to its specifications, the EUT must comply with the requirements of the Section 74.861 under the FCC Rules Part 74 Subpart H.

3. SYSTEM TEST CONFIGURATION

3.1 Justification

The system was configured for testing in a continuous transmits condition.

3.2 EUT Exercise Software

N/A.

3.3 Special Accessories

N/A.

3.4 Block Diagram/Schematics

Please refer to the related document.

3.5 Equipment Modifications

Shenzhen LCS Compliance Testing Laboratory Ltd. has not done any modification on the EUT.

3.6 Test Setup

Please refer to the test setup photo.

4. SUMMARY OF TEST RESULTS

Applied Standard: FCC Part 74 Subpart H			
FCC Rules	Description of Test	Limit	Result
§74.861(e)(1)	Maximum Output Power	(i)54-72, 76-88, and 174-216 MHz bands: 50 mW EIRP (ii)470-608 and 614-698: 250 mW conducted power (iii)600 MHz duplex gap: 20 mW EIRP	Compliant
§74.861(e)(3) §2.1047	Frequency Modulation Modulation Characteristics	Maximum deviation: ±75 kHz	Compliant
§74.861(e)(4)	Frequency Tolerance	0.005 percent	Compliant
§74.861(e)(5)	Operating Bandwidth	Less than 200kHz	Compliant
§74.861(e)(6)	Unwanted Emission	(i)50%~100% authorized bandwidth: At least 25dB; (ii)100%~250% authorized bandwidth: At least 35dB; (ii)More than 250% authorized bandwidth: At least 43 + 10log10 (mean output power in watts) dB;	Compliant
§74.861(e)(7)	Necessary bandwidth	Prefer to ETSI EN 300 422-1 v1.4.2 (2011-08) Section 8.3.1.2	Compliant

5. SUMMARY OF TEST EQUIPMENT

Item	Equipment	Manufacturer	Model No.	Serial No.	Last Cal.	Next Cal.
1	DC Filter	MPE	23872C	N/A	2016-06-18	2017-06-17
2	RF Cable	Harbour Industries	1452	N/A	2016-06-18	2017-06-17
3	SMA Connector	Harbour Industries	9625	N/A	2016-06-18	2017-06-17
4	Spectrum Analyzer	Agilent	N9020A	MY50510140	2015-10-27	2016-10-26
5	RF Cable	Hubersuhne	Sucoflex104	FP2RX2	2016-06-18	2017-06-17
6	3m Semi Anechoic Chamber	SIDT FRANKONIA	SAC-3M	03CH03-HY	2016-06-18	2017-06-17
7	Amplifier	SCHAFFNER	COA9231A	18667	2016-06-18	2017-06-17
8	Amplifier	Agilent	8449B	3008A02120	2016-06-16	2017-06-15
9	Amplifier	MITEQ	AMF-6F-260400	9121372	2016-06-16	2017-06-15
10	Loop Antenna	R&S	HFH2-Z2	860004/001	2016-06-18	2017-06-17
11	By-log Antenna	SCHWARZBECK	VULB9163	9163-470	2016-06-10	2017-06-09
12	By-log Antenna	SCHWARZBECK	VULB9163	9163-484	2016-06-10	2017-06-09
13	Horn Antenna	EMCO	3115	6741	2016-06-10	2017-06-09
14	Horn Antenna	SCHWARZBECK	BBHA9170	BBHA9170154	2016-06-10	2017-06-09
15	RF Cable-R03m	Jye Bao	RG142	CB021	2016-06-18	2017-06-17
16	RF Cable-HIGH	SUHNER	SUCOFLEX 106	03CH03-HY	2016-06-18	2017-06-17
19	EMI Test Software	AUDIX	E3	N/A	2016-06-18	2017-06-17
20	Oscilloscope	Tektonix	TDS380	B016197	2016-06-18	2017-06-17
21	RF COMMUNICATION TEST SET	HP	8920A	3813A10254	2016-10-25	2017-10-24
22	Temperature & Humidity Chamber	Wuhuan	HTP205	/	2016-06-18	2017-06-17

6. MAXMIUM OUTPUT POWER

6.1 Limit

According to §74.861(e) (1), the power may not exceed the following values:

- (i) 54-72, 76-88, and 174-216 MHz bands: 50 mW EIRP
- (ii) 470-608 and 614-698: 250 mW conducted power
- (iii) 600 MHz duplex gap: 20 mW EIRP

6.2 Test Procedure

1). EUT was placed on a 1.50 meter high non-conductive stand at a 3 meter test distance from the receive antenna. A receiving antenna was placed on the antenna mast 3 meters from the EUT for emission measurements. The height of receiving antenna is 1.50m. Detected emissions were maximized at each frequency by rotating the EUT through 360° and adjusting the receiving antenna polarization. The radiated emission measurements of all transmit frequencies in three channels (High, Middle, Low) were measured with peak detector.

2). A log-periodic antenna or double-ridged waveguide horn antenna shall be substituted in place of the EUT. The log-periodic antenna will be driven by a signal generator and the level will be adjusted till the same power value on the spectrum analyzer or receiver. The level of the spurious emissions can be calculated through the level of the signal generator, cable loss, the gain of the substitution antenna and the reading of the spectrum analyzer or receiver.

3). The EUT is then put into continuously transmitting mode at its maximum power level during the test. Set Test Receiver or Spectrum RBW=1MHz, VBW=1MHz, And the maximum value of the receiver should be recorded as (Pr).

4). The EUT shall be replaced by a substitution antenna. In the chamber, a substitution antenna for the frequency band of interest is placed at the reference point of the chamber. An RF Signal source for the frequency band of interest is connected to the substitution antenna with a cable that has been constructed to not interfere with the radiation pattern of the antenna. A power (P_{Mea}) is applied to the input of the substitution antenna, and adjusts the level of the signal generator output until the value of the receiver reach the previously recorded (Pr). The power of signal source (P_{Mea}) is recorded. The test should be performed by rotating the test item and adjusting the receiving antenna polarization.

5). A amplifier should be connected to the Signal Source output port. And the cable should be connect between the Amplifier and the Substitution Antenna. The cable loss (P_{cl}), the Substitution Antenna Gain (G_a) and the Amplifier Gain (P_{Ag}) should be recorded after test.

The measurement results are obtained as described below:

$$\text{Power (EIRP)} = P_{Mea} - P_{Ag} - P_{cl} + G_a$$

6). this value is EIRP since the measurement is calibrated using an antenna of known gain (2.15 dBi) and known input power.

7). ERP can be calculated from EIRP by subtracting the gain of the dipole, $ERP = EIRP - 2.15\text{dBi}$.

6.3 Test Configuring

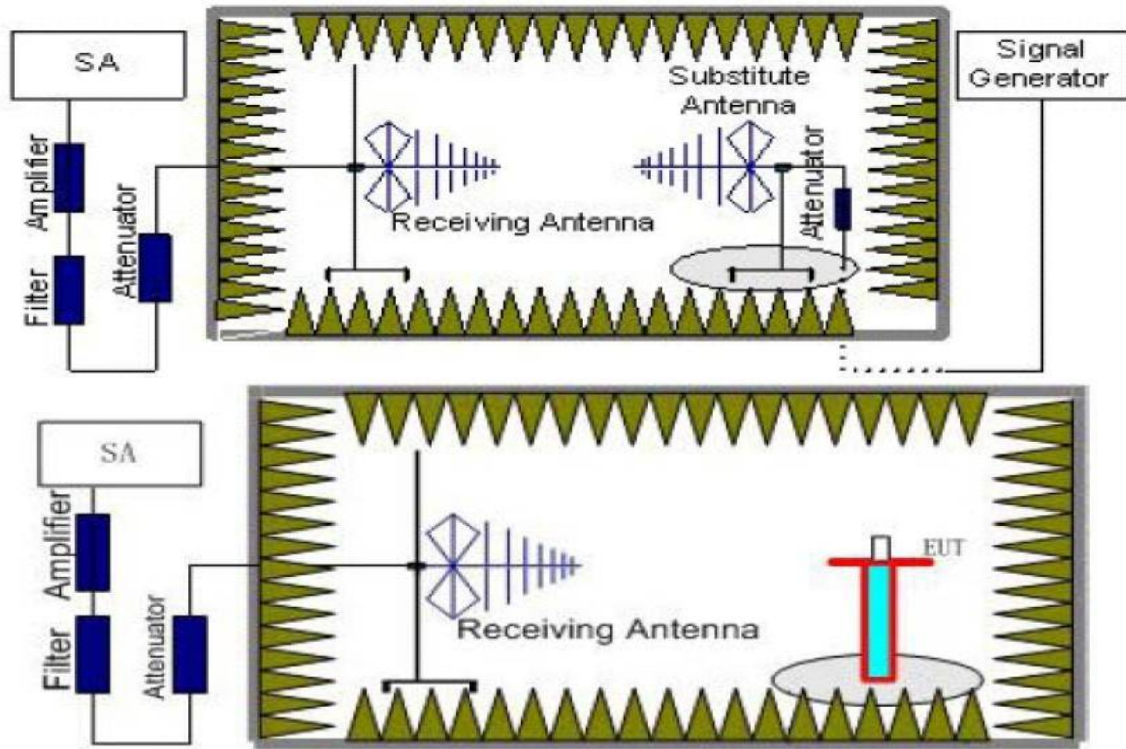

6.4 Test Results

Test Mode	Frequency (MHz)	EIRP Output Power (dBm)	EIRP Output Power (mw)	Limit (mW)	Result
FM	185.15	14.351	27.2333	50	Pass
	202.20	14.662	29.2550	50	Pass

7. MODULATION CHARACTERISTICS

7.1 Limit

- 1). According to §74.861(e)(3): A maximum deviation of ± 75 kHz is permitted when frequency modulation is employed.
- 2). According to CFR 47 section 2.1047(a), Voice Modulation Communication Equipment, the frequency Response of the audio modulation circuit over a range of 100 to 5000Hz shall be measured.
- 3). Equipment which employs modulation limiting. A curve or family of curves showing the percentage of modulation versus the modulation input voltage shall be supplied.

7.2 Test Procedure

7.2.1 Modulation Limit

- 1). Configure the EUT as shown in figure 7-1, adjust the audio input for 60% of rated system deviation at 1KHz using this level as a reference (0dB) and vary the input level from -20 to $+20$ dB. Record the frequency Deviation obtained as a function of the input level.
- 2). Repeat step 1 with input frequency changing to 300, 1000, 3000, and 12000 Hz in sequence.

7.2.2 Audio Frequency Response

- 1). Configure the EUT as shown in figure 7-1.
- 2). Adjust the audio input for 20% of rated system deviation at 1 KHz using this level as a reference (0 dB).
- 3). Vary the Audio frequency from 100 Hz to 5 KHz and record the frequency deviation.
- 4). Audio Frequency Response = $20\log_{10}$ (Deviation of test frequency/Deviation of 1 KHz reference).

7.3 Test Configuring

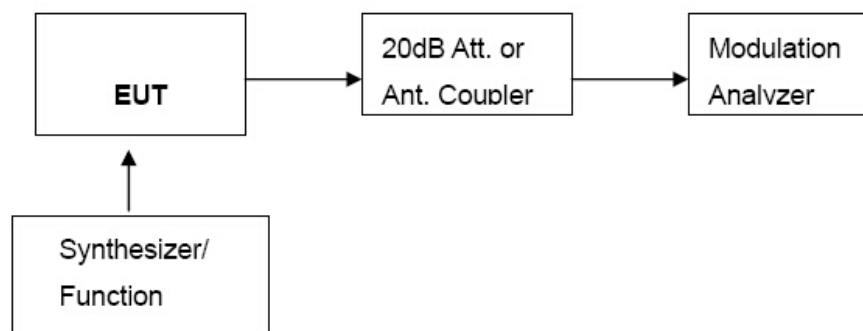
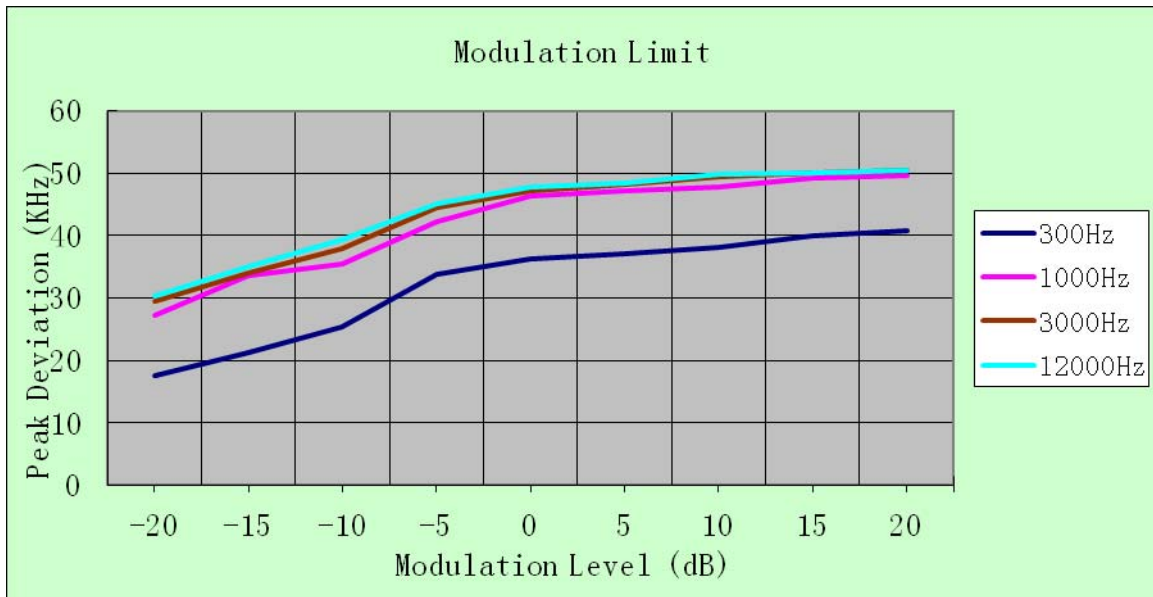

Figure 7-1: Modulation Characteristic Measurement Configuration

7.4 Test Results

Test data of Modulation Limit 185.15MHz				
Modulation Level (dB)	Peak Freq. Deviation At 300 Hz (KHz)	Peak Freq. Deviation At 1000 Hz (KHz)	Peak Freq. Deviation At 3000 Hz (KHz)	Peak Freq. Deviation At 12000 Hz (KHz)
-20	17.62	27.21	29.52	30.41
-15	21.25	33.69	34.02	35.11
-10	25.41	35.48	37.95	39.41
-5	33.75	42.16	44.47	45.12
0	36.33	46.42	47.15	47.89
+5	37.08	47.11	48.12	48.52
+10	38.11	47.87	49.52	49.89
+15	39.95	49.23	49.98	50.12
+20	40.86	49.65	50.54	50.45



Test data of Modulation Limit 202.20MHz				
Modulation Level (dB)	Peak Freq. Deviation At 300 Hz (KHz)	Peak Freq. Deviation At 1000 Hz (KHz)	Peak Freq. Deviation At 3000 Hz (KHz)	Peak Freq. Deviation At 12000 Hz (KHz)
-20	17.52	27.46	29.41	30.52
-15	21.74	33.22	34.34	35.63
-10	25.01	35.45	37.12	39.56
-5	33.22	42.41	44.78	45.52
0	36.37	46.74	47.26	47.14
+5	37.48	47.01	48.12	48.33
+10	38.46	47.36	49.36	49.78
+15	39.77	49.55	49.12	50.20
+20	40.01	49.78	50.73	50.77

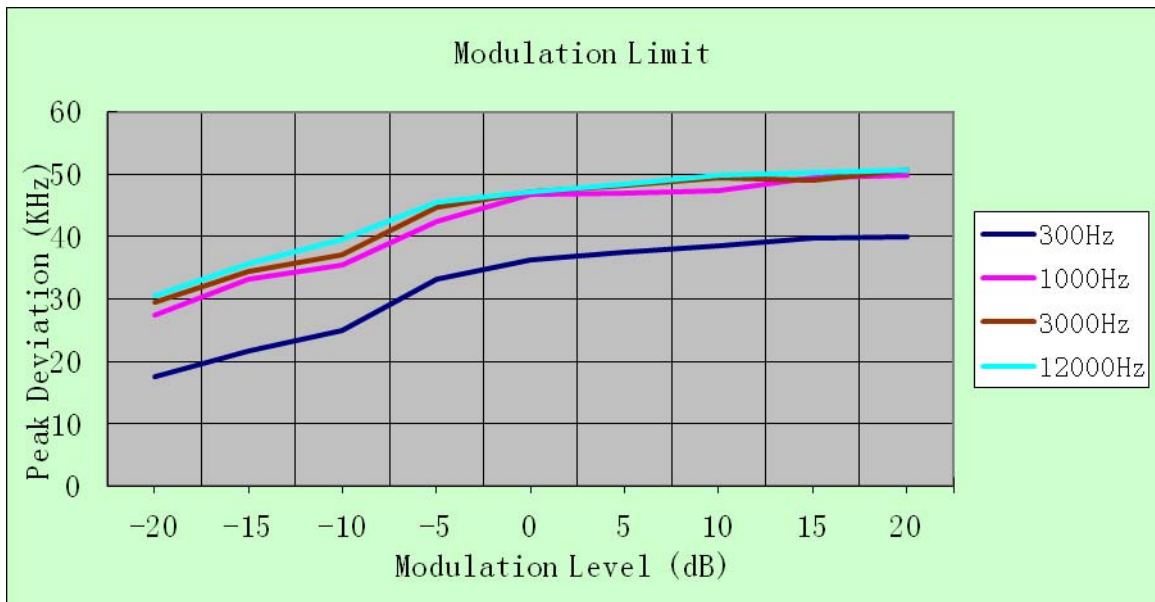

Test data of Audio Frequency Response 185.15MHz		
Frequency (Hz)	Deviation (KHz)	Measured Value(dB)
100	8.21	-4.86
200	9.72	-3.40
300	10.45	-2.77
400	11.32	-2.07
500	11.71	-1.78
600	12.41	-1.27
700	12.67	-1.09
800	13.11	-0.80
900	13.28	-0.69
1000	14.37	0.00
1200	14.69	0.19
1400	15.44	0.62
1600	15.85	0.85
1800	16.54	1.22
2000	17.23	1.58
2400	17.56	1.74
2500	17.88	1.90
2800	18.11	2.01
3000	18.37	2.13
3400	19.12	2.48
3800	19.57	2.68
4000	19.62	2.70
4500	19.77	2.77
5000	19.55	2.67

Note: Measured Value=20log10 (Deviation of test frequency/Deviation of 1 KHz reference)

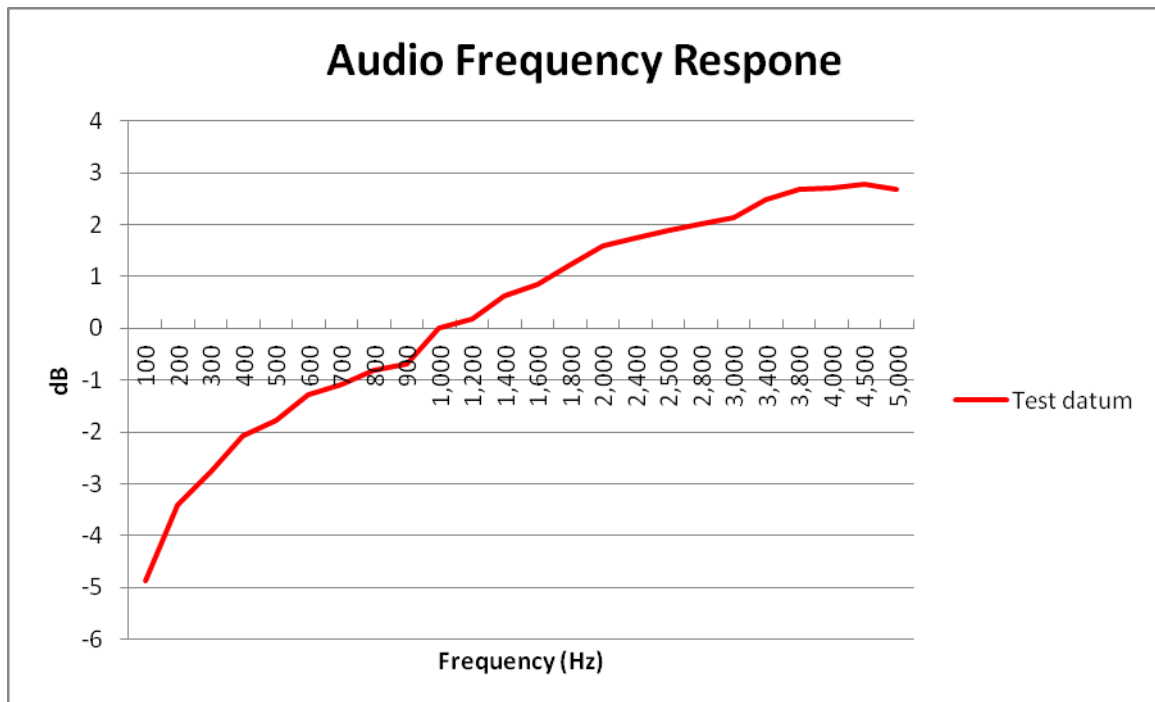

Test data of Audio Frequency Response 202.20MHz		
Frequency (Hz)	Deviation (KHz)	Measured Value(dB)
100	8.78	-4.20
200	9.45	-3.56
300	10.01	-3.06
400	11.38	-1.95
500	11.77	-1.65
600	12.45	-1.17
700	12.89	-0.87
800	13.51	-0.46
900	13.98	-0.16
1000	14.24	0.00
1200	14.74	0.30
1400	15.44	0.70
1600	15.89	0.95
1800	16.01	1.02
2000	17.52	1.80
2400	17.79	1.93
2500	17.94	2.01
2800	18.06	2.06
3000	18.47	2.26
3400	19.44	2.70
3800	19.78	2.85
4000	19.52	2.74
4500	19.32	2.65
5000	19.17	2.58

Note: Measured Value=20log10 (Deviation of test frequency/Deviation of 1 KHz reference)

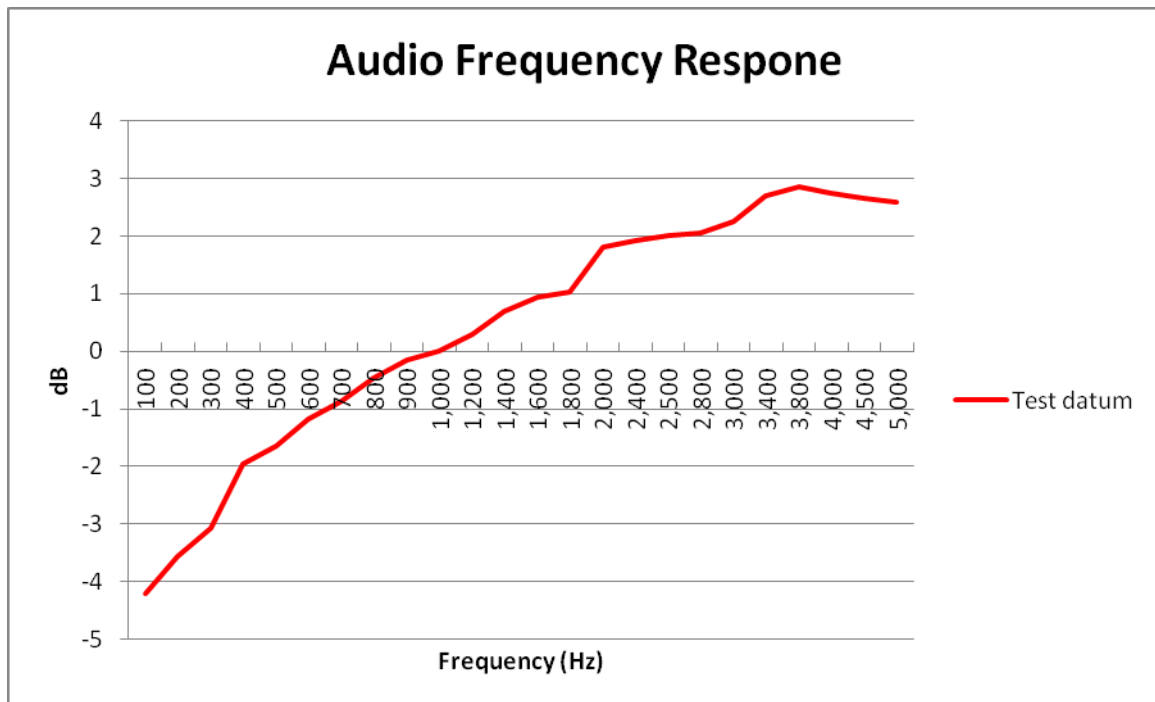

8. FREQUENCY TOLERANCE

8.1 Limit

- 1). According to §74.861(e)(4), The frequency tolerance of the transmitter shall be 0.005 percent.
- 2). According to FCC Part 2 Section 2.1055(a)(1), the frequency stability shall be measured with variation of ambient temperature from -30°C to $+50^{\circ}\text{C}$ centigrade.
- 3). According to FCC Part 2 Section 2.1055(d)(2), for hand carried battery powered equipment, the frequency stability shall be measured with reducing primary supply voltage to the battery operating end point, which is specified by the manufacture.

8.2 Test Configuring

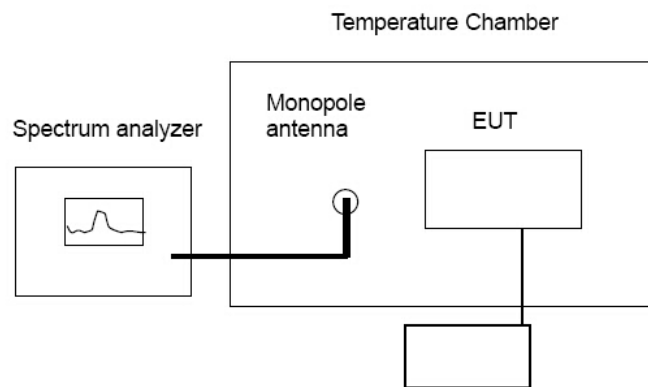

Figure 8-1

8.3 Test Procedure

8.3.1 FREQUENCY STABILITY VERSUS ENVIRONMENTAL TEMPERATURE

- 1). Setup the configuration per figure 8-1 for frequencies measurement inside an environment chamber, install new battery in the EUT.
- 2). Turn on EUT and set SA center frequency to the EUT radiated frequency. Set SA Resolution Bandwidth to 1KHz and Video Resolution Bandwidth to 1KHz and Frequency Span to 50KHz. Record this frequency as reference frequency.
- 3). Set the temperature of chamber to 50°C . Allow sufficient time (approximately 30 min) for the temperature of the chamber to stabilize. While maintaining a constant temperature inside the chamber, turn the EUT on and measure the EUT operating frequency.
- 4). Repeat step 2 with a 10°C decreased per stage until the lowest temperature -30°C is measured, record all measured frequencies on each temperature step.

8.3.2 FREQUENCY STABILITY VERSUS INPUT VOLTAGE

- 1). Setup the configuration per figure 8-1 for frequencies measured at temperature if it is within 15°C to 25°C . Otherwise, an environment chamber set for a temperature of 20°C shall be used. Install new battery in the EUT.
- 2). Set SA center frequency to the EUT radiated frequency. Set SA Resolution Bandwidth to 1 KHz and Video Resolution Bandwidth to 1KHz. Record this frequency as reference frequency.
- 3). For battery operated only device, supply the EUT primary voltage at the operating end point which is specified by manufacturer and record the frequency.

8.4 Test Results

The data of frequency stability versus input voltage				Test Result
Test Frequency (MHz)	Frequency Measured at End Point Voltage (MHz)	Frequency Error (%)	Limit (%)	
185.15	185.1514	0.00076	0.005	Pass
202.20	202.2035	0.00173	0.005	Pass

Note: Test environment temperature is 25°C

The data of frequency stability versus ambient temperature				
Environment Temperature (°C)	Channel Frequency: 185.15MHz		Limit (%)	Test Result
	Frequency Measured with time Elapsed (MHz)	Frequency Error (%)		
-30	185.1515	0.00081	0.005	Pass
-20	185.1511	0.00059	0.005	Pass
-10	185.1509	0.00049	0.005	Pass
0	185.1520	0.00108	0.005	Pass
10	185.1519	0.00103	0.005	Pass
20	185.1514	0.00076	0.005	Pass
30	185.1522	0.00119	0.005	Pass
40	185.1511	0.00059	0.005	Pass
50	185.1517	0.00092	0.005	Pass

The data of frequency stability versus ambient temperature				
Environment Temperature (°C)	Channel Frequency: 202.20MHz		Limit (%)	Test Result
	Frequency Measured with time Elapsed (MHz)	Frequency Error (%)		
-30	202.2041	0.00203	0.005	Pass
-20	202.2027	0.00134	0.005	Pass
-10	202.2037	0.00183	0.005	Pass
0	202.2034	0.00168	0.005	Pass
10	202.2029	0.00143	0.005	Pass
20	202.2031	0.00153	0.005	Pass
30	202.2045	0.00223	0.005	Pass
40	202.2033	0.00163	0.005	Pass
50	202.2042	0.00208	0.005	Pass

Note: Test input voltage is DC 3.0V

9. OPERATING BANDWIDTH

9.1 Limit

According to §74.861(e)(5), The operating bandwidth shall not exceed 200 kHz.

9.2 Test Configuring

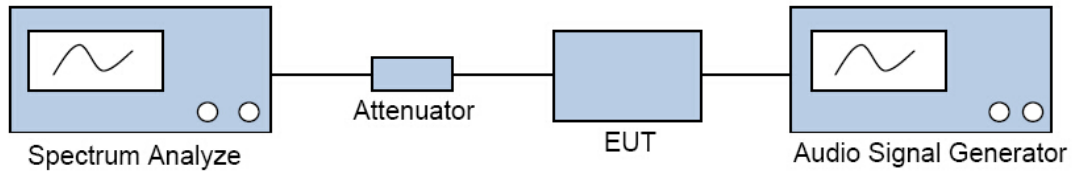

9.3 Test Procedure

- 1). Place the EUT on the table and set it in transmitting mode with 2.5 kHz tone signal.
- 2). Remove the antenna from the EUT and then connect a low loss RF cable from the antenna port to the Spectrum Analyzer.
- 3). Set center frequency of Spectrum Analyzer = operating frequency.
- 4). Set the Spectrum Analyzer as RBW=3 kHz, VBW=10 kHz, Span = 300 kHz, Sweep = auto.
- 5). Repeat above procedures until all frequency measured was complete.

9.4 Test Results

Test Result of Operating Bandwidth		
Channel Frequency (MHz)	Measured Result (kHz)	Limit (kHz)
185.15	82.420	200
202.20	72.991	200

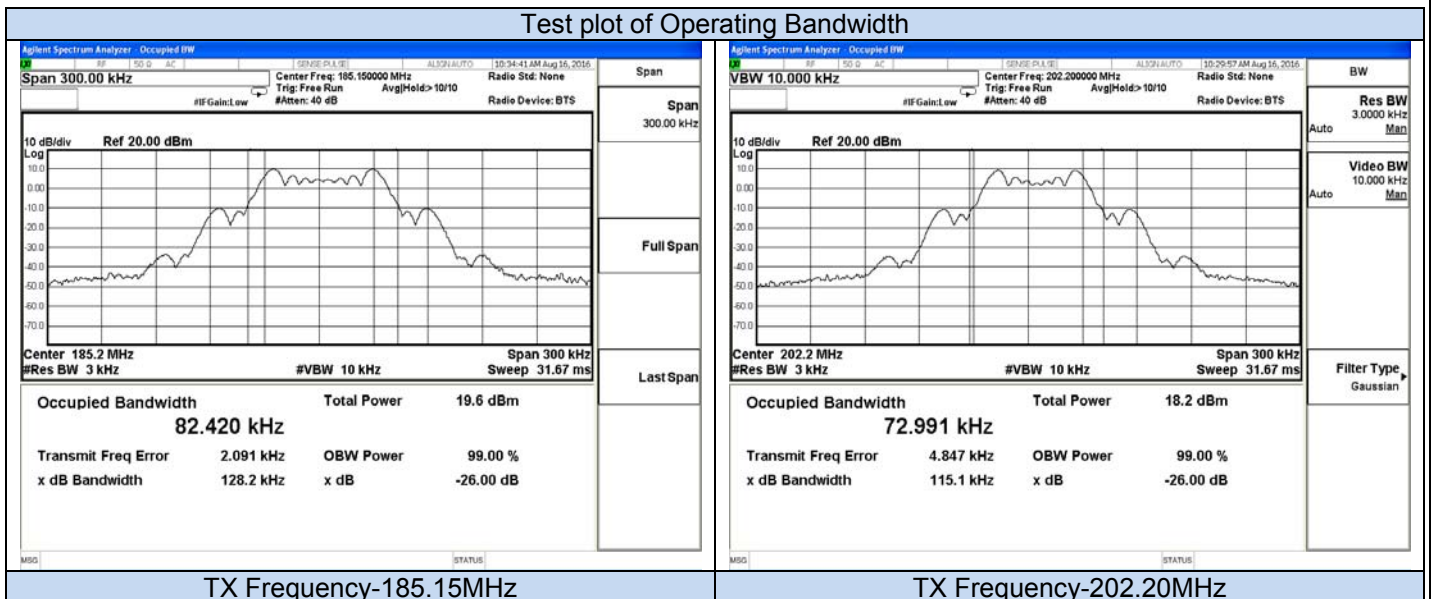

10. UNWANTED EMISSION

10.1 Limit

According to §74.861(e)(6), The mean power of emissions shall be attenuated below the mean output power of the transmitter in accordance with the following schedule:

- (i) On any frequency removed from the operating frequency by more than 50 percent up to and including 100 percent of the authorized bandwidth: at least 25 dB;
- (ii) On any frequency removed from the operating frequency by more than 100 percent up to and including 250 percent of the authorized bandwidth: at least 35 dB;
- (iii) On any frequency removed from the operating frequency by more than 250 percent of the authorized bandwidth: at least $43 + 10\log_{10}$ (mean output power in watts) dB.

10.2 Test Configuration

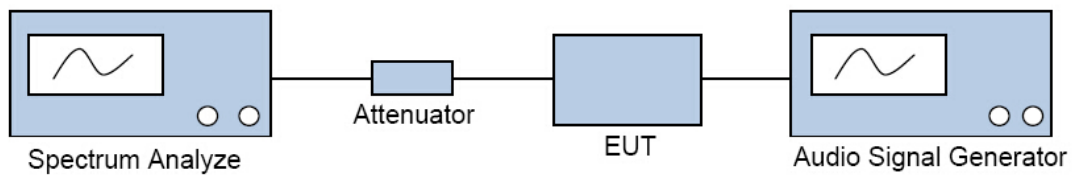

Figure 10-1: Test Setup for Conducted Emission

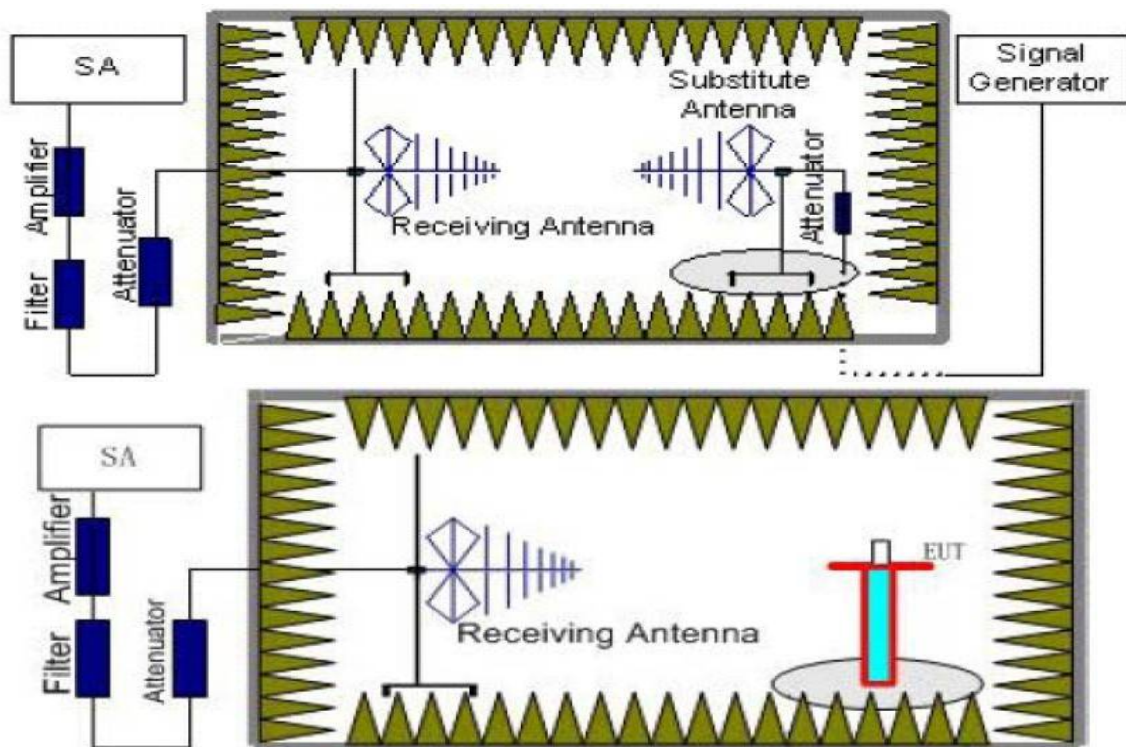

Figure 10-2: Test Setup for Radiated Emission

10.3 Test Procedure

During the measurement the EUT works with a 2.5 kHz tone signal.

10.3.1 Conducted Emission

Conducted RF measurements of the Unwanted Radiation were made to confirm that the EUT antenna port conducted emissions meet the specified limit and to identify any spurious signals that require further investigation or measurements on the radiated emissions site.

The transmitter output is connected to the spectrum analyzer. The resolution bandwidth is set to 1 kHz. The video bandwidth is set to 3 kHz. The span is set to 1MHz

10.3.2 Radiated Emission

1). EUT was placed on a 1.50 meter high non-conductive stand at a 3 meter test distance from the receive antenna. A receiving antenna was placed on the antenna mast 3 meters from the EUT for emission measurements. The height of receiving antenna is 1.50m. Detected emissions were maximized at each frequency by rotating the EUT through 360° and adjusting the receiving antenna polarization. The radiated emission measurements of all transmit frequencies in three channels (High, Middle, Low) were measured with peak detector.

2). A log-periodic antenna or double-ridged waveguide horn antenna shall be substituted in place of the EUT. The log-periodic antenna will be driven by a signal generator and the level will be adjusted till the same power value on the spectrum analyzer or receiver. The level of the spurious emissions can be calculated through the level of the signal generator, cable loss, the gain of the substitution antenna and the reading of the spectrum analyzer or receiver.

3). The EUT is then put into continuously transmitting mode at its maximum power level during the test. Set Test Receiver or Spectrum RBW=1MHz, VBW=1MHz, And the maximum value of the receiver should be recorded as (P_r).

4). The EUT shall be replaced by a substitution antenna. In the chamber, an substitution antenna for the frequency band of interest is placed at the reference point of the chamber. An RF Signal source for the frequency band of interest is connected to the substitution antenna with a cable that has been constructed to not interfere with the radiation pattern of the antenna. A power (P_{Mea}) is applied to the input of the substitution antenna, and adjust the level of the signal generator output until the value of the receiver reach the previously recorded (P_r). The power of signal source (P_{Mea}) is recorded. The test should be performed by rotating the test item and adjusting the receiving antenna polarization.

5). A amplifier should be connected to the Signal Source output port. And the cable should be connect between the Amplifier and the Substitution Antenna. The cable loss (P_{cl}), the Substitution Antenna Gain (G_a) and the Amplifier Gain (P_{Ag}) should be recorded after test.

The measurement results are obtained as described below:

$$\text{Power(EIRP)} = P_{Mea} - P_{Ag} - P_{cl} + G_a$$

6). This value is EIRP since the measurement is calibrated using an antenna of known gain (2.15 dBi) and known input power.

7). ERP can be calculated from EIRP by subtracting the gain of the dipole, $ERP = EIRP - 2.15\text{dBi}$.

Subrange (GHz)	RBW	VBW	Sweep time (s)
0.00009~0.15	1KHz	3KHz	30
0.00015~0.03	10KHz	30KHz	10
0.03~1	100KHz	300KHz	10
1~3	1 MHz	3 MHz	2

10.4 Test Results of Conducted Emissions Mask

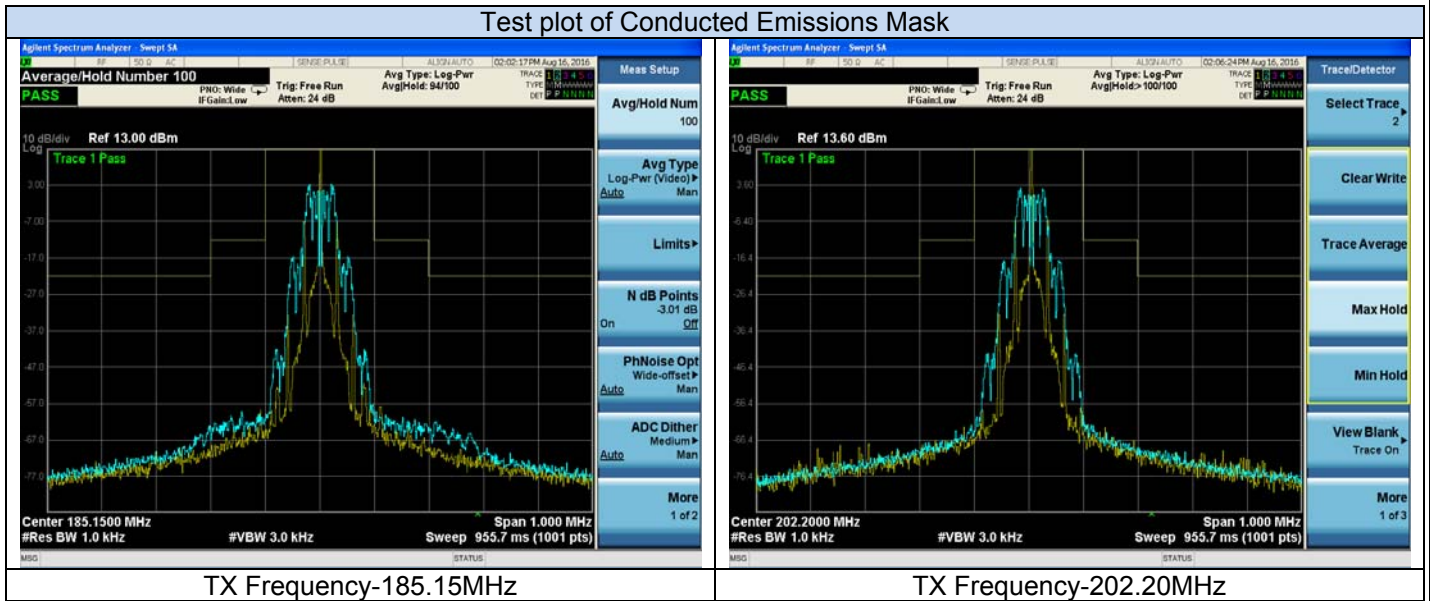

10.5 Test Results of Radiated Emissions

Calculation: Limit (dBm)= EL-43-10lg (TP)

Notes: No emission found below 30MHz, EL is the emission level of the Output

Power expressed in dBm, TP=[10^(EL/10)]/1000 W.

Limit (dBm)=EL-43-10lg(TP) = -13dBm

Channel Frequency-185.15MHz								
Frequency (MHz)	PMea (dBm)	Pcl (dB)	Distance (m)	Ga Antenna Gain (dB)	EIRP (dBm)	Limit (dBm)	Margin (dB)	Polarization
370.31	-25.68	3.22	3	8.12	-20.78	-13.00	-7.78	H
370.31	-27.34	3.22	3	8.12	-22.44	-13.00	-9.44	V
555.45	-24.30	3.41	3	8.10	-19.61	-13.00	-6.61	H
555.45	-27.06	3.41	3	8.10	-22.37	-13.00	-9.37	V
740.60	-27.29	3.44	3	8.21	-22.52	-13.00	-9.52	H
740.60	-28.94	3.44	3	8.21	-24.17	-13.00	-11.17	V

Channel Frequency-202.20MHz								
Frequency (MHz)	PMea (dBm)	Pcl (dB)	Distance (m)	Ga Antenna Gain (dB)	EIRP (dBm)	Limit (dBm)	Margin (dB)	Polarization
404.44	-26.13	3.23	3	8.13	-21.23	-13.00	-8.23	H
404.44	-28.68	3.23	3	8.13	-23.78	-13.00	-10.78	V
606.62	-24.91	3.43	3	8.19	-20.15	-13.00	-7.15	H
606.62	-27.74	3.43	3	8.19	-22.98	-13.00	-9.98	V
808.83	-26.95	3.47	3	8.25	-22.17	-13.00	-9.17	H
808.83	-30.25	3.47	3	8.25	-25.47	-13.00	-12.47	V

Note:

- 1). All test modes have been tested and we only record the worst result.
- 2). Measuring frequencies from 9k~10th harmonic (ex. 3GHz), No emission found between lowest internal used/generated frequency to 30 MHz.
- 2). Radiated emissions measured in frequency range from 9k~10th harmonic (ex. 3GHz) were made with an instrument using Peak detector mode.

11. NECESSARY BANDWIDTH

11.1 Limit

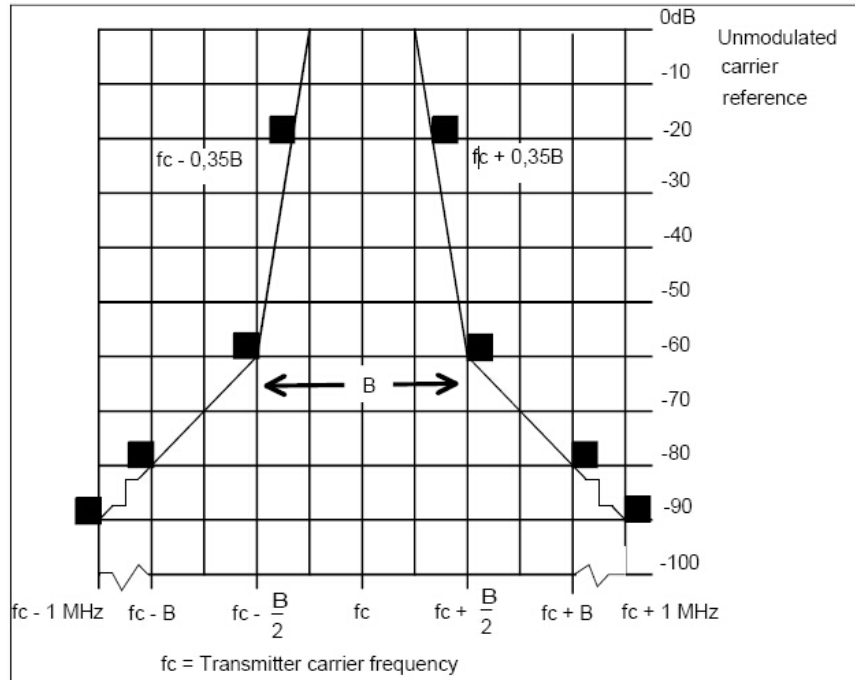

11.2 Test Configuration

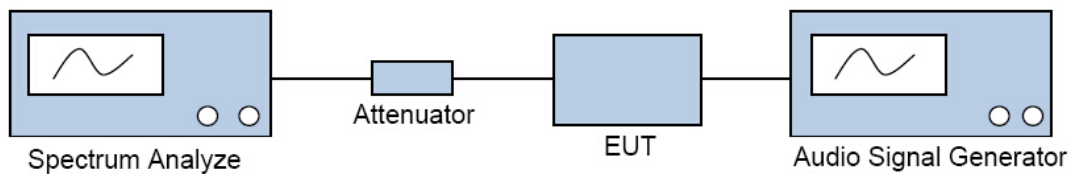

Figure 11-1: Test Setup for Necessary bandwidth Test

11.3 Instruments Setting

- 1). Centre frequency: f_c : Transmitter (Tx) nominal frequency;
- 2). Dispersion (Span): $f_c - 1\text{ MHz}$ to $f_c + 1\text{ MHz}$;
- 3). Resolution BandWidth (RBW): 1 kHz;
- 4). Video BandWidth (VBW): 1 kHz;
- 5). Detector: Peak hold.

11.4 Test Procedures

- 1). With the Low Frequency (LF) audio signal generator set to 500 Hz, the audio input level to the EUT shall be adjusted to 8 dB below the limiting threshold (-8 dB (lim)) as declared by the manufacturer.
- 2). The corresponding audio output level from the demodulator shall be measured and recorded.
- 3). The input impedance of the noise meter shall be sufficiently high to avoid more than 0,1 dB change in input level when the meter is switched between input and output.
- 4). The audio input level shall be increased by 20 dB, i.e. to +12 dB (lim), and the corresponding change in output level shall be measured.
- 5). It shall be checked that the audio output level has increased by ≤ 10 dB.
- 6). If this condition is not met, the initial audio input level shall be increased from -8 dB (lim) in 1 dB steps until the above condition is fulfilled, and the input level recorded in the test report. This level replaces the value derived from the manufacturer's declaration and is defined as -8 dB (lim).
- 7). Measure the input level at the transmitter required to give +12 dB (lim).

11.5 Test Results

Test plot of Necessary bandwidth for 185.15MHz (+12dB)

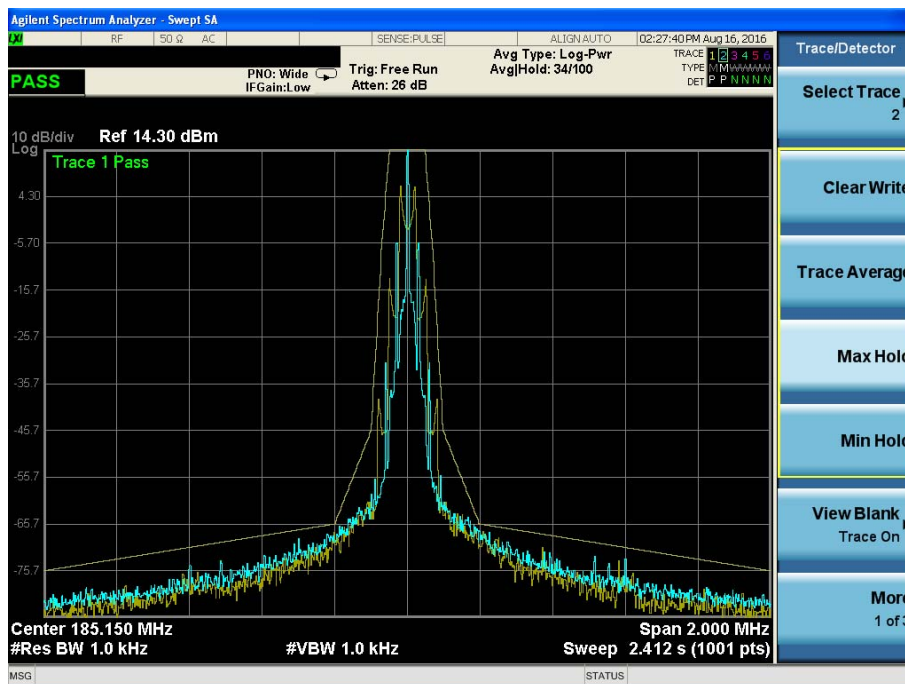

Test plot of Necessary bandwidth for 202.20MHz (+12dB)

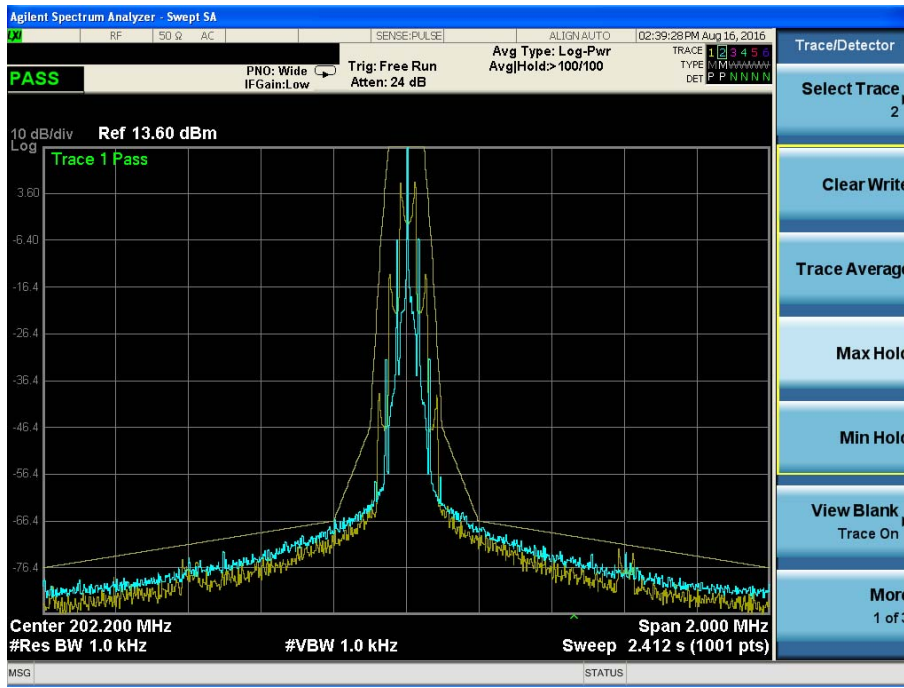

Note:

- 1). All test modes have been tested and we only show the worst result.

12. TEST SETUP PHOTOS OF THE EUT

Please refer to separated files for Test Setup Photos of the EUT.

13. EXTERNAL PHOTOS OF THE EUT

Please refer to separated files for External Photos of the EUT.

14. INTERNAL PHOTOS OF THE EUT

Please refer to separated files for Internal Photos of the EUT.

-----THE END OF REPORT-----