

# RF TEST REPORT

**Report No.** : 160728012SZN-004  
**Model No.** : TWFP-M601D  
**Issued Date** : 31 August 2016

**Applicant:** Shen Zhen MTC Co., LTD  
Co., LTD MTC Industry Park, 1st Lilang Road, Xialilang  
community, Nanwan street, Longgang district, Shenzhen,  
China

**Test Method/  
Standard:** FCC Part 15 Subpart E;  
KDB 789033 D02 v01r03;  
KDB 662911 D01 v02r01;  
ANSI C63.10-2013

**Test By:** Intertek Testing Services Shenzhen Ltd. Kejiyuan Branch  
6F, D Block, Huahan Building, Langshan Road,  
Nanshan District, Shenzhen, P. R. China

**The test report was prepared by:** Sign on File  
Powell Bao / Engineer

**The test report was reviewed by:**

**Name** Kidd Yang  
**Title** Senior Project Engineer

- The test results reported in this test report shall refer only to the sample actually tested and shall not refer or be deemed to refer to bulk from which such a sample may be said to have been obtained.
- This report is for the exclusive use of Intertek's Client and is provided pursuant to the agreement between Intertek and its Client. Intertek's responsibility and liability are limited to the terms and conditions of the agreement. Intertek assumes no liability to any party, other than to the Client in accordance with the agreement, for any loss, expense or damage occasioned by the use of this report. Only the Client is authorized to copy or distribute this report. Any use of the Intertek name or one of its marks for the sale or advertisement of the tested material, product or service must first be approved in writing by Intertek. The observations and test results referenced from this report are relevant only to the sample tested. This report by itself does not imply that the material, product, or service is or has ever been under an Intertek certification program.
- For Terms And Conditions of the services, it can be provided upon request.
- The evaluation data of the report will be kept for 3 years from the date of issuance.

## Table of Contents

|  |    |
|--|----|
| Summary of Tests .....   | 3  |
| 1. General information .....   | 4  |
| 1.1 Identification of the EUT .....                                      | 4  |
| 1.2 Additional information about the EUT .....                           | 5  |
| 1.3 Antenna description (15.203) .....                                   | 5  |
| 1.4 Peripherals equipment .....  | 5  |
| 2. Test specifications .....   | 6  |
| 2.1 Test standard .....  | 6  |
| 2.2 Operation mode .....   | 7  |
| 3. Maximum Output Power test (FCC 15.407) .....                          | 8  |
| 3.1 Operating environment .....  | 8  |
| 3.2 Test setup & procedure .....   | 8  |
| 3.3 Limit .....  | 8  |
| 3.4 Measured data of Maximum Output Power test results .....             | 9  |
| 4. Power Spectrum Density test (FCC 15.407) .....                        | 13 |
| 4.1 Operating environment .....  | 13 |
| 4.2 Test setup & procedure .....   | 13 |
| 4.3 Limit .....  | 13 |
| 4.4 Measured data of Power Spectrum Density test results .....           | 14 |
| 5. Minimum 6 dB RF Bandwidth (FCC 15.407) .....                          | 16 |
| 5.1 Operating environment .....  | 16 |
| 5.2 Test setup & procedure .....   | 16 |
| 5.3 Limit .....  | 16 |
| 5.4 Measured data of Minimum 6 dB RF Bandwidth test results .....        | 17 |
| 6. Radiated Emission test (FCC 15.205 & 15.209 & 15.407) .....           | 18 |
| 6.1 Operating environment .....  | 18 |
| 6.2 Test setup & procedure .....   | 18 |
| 6.3 Limit .....  | 20 |
| 6.4 Radiated spurious emission test data .....                           | 22 |
| 6.4.1 Measurement results: frequencies equal to or less than 1 GHz ..... | 22 |
| 6.4.2 Measurement results: frequency above 1GHz .....                    | 23 |
| 7. Power Line Conducted Emission test .....                              | 41 |
| 7.1 Operating environment .....  | 41 |
| 7.2 Test setup & procedure .....   | 41 |
| 7.3 Limit .....  | 42 |
| 7.4 Power Line Conducted Emission test data .....                        | 43 |
| 8. Frequency Stability Test .....  | 45 |
| 8.1 Test setup & procedure .....   | 45 |
| 8.2 Frequency Stability Test Data .....                                  | 45 |

### Summary of Tests

| FCC Parts                   | Test                            | Section | Results |
|-----------------------------|---------------------------------|---------|---------|
| 15.203                      | Antenna Requirement             | 1.3     | Pass    |
| 15.407 a (1)/(3)            | Maximum output power test       | 3       | Pass    |
| 15.407 a (1)/(3)            | Power Spectrum Density test     | 4       | Pass    |
| 15.407 e                    | 6dB Bandwidth                   | 5       | Pass    |
| 15.407 b,<br>15.205, 15.209 | Radiated spurious emission test | 6       | Pass    |
| 15.207                      | AC line conducted emission test | 7       | Pass    |
| 15.407 g                    | Frequency Stability             | 8       | Pass    |

## 1. General information

### 1.1 Identification of the EUT

|                            |  |
|----------------------------|--|
| Product:                   | WiFi Module  |
| Model No.:                 | TWFP-M601D   |
| Type of Device:            | Master device  |
| Nominal Channel Bandwidth: | 802.11a/n-HT20 (20 MHz), 802.11n-HT40 (40MHz), 802.11ac (20/40/80MHz)  |
| Operating Frequency:       | 1. 5180 MHz ~ 5240 MHz<br>2. 5745 MHz ~ 5825 MHz   |
| Channel Number:            | 4 channels for 5180 MHz ~ 5240 MHz for 802.11a/n/ac-HT20;<br>2 channels for 5190 MHz ~ 5230 MHz for 802.11n/ac-HT40;<br>1 channels for 5210 MHz for 802.11ac;<br>5 channels for 5745 MHz ~ 5825 MHz for 802.11a/n/ac-HT20;<br>2 channels for 5755 MHz ~ 5795 MHz for 802.11n/ac-HT40<br>1 channels for 5775 MHz for 802.11ac   |
| Rated Power:               | 5.0Vdc, 1.5A from adapter<br>(Model No.: GAC-002)  |
| Test Date(s):              | 1 August 2016 to 30 August 2016  |
| Note 1:                    | This report is for the exclusive use of Intertek's Client and is provided pursuant to the agreement between Intertek and its Client. Intertek's responsibility and liability are limited to the terms and conditions of the agreement. Intertek assumes no liability to any party, other than to the Client in accordance with the agreement, for any loss, expense or damage occasioned by the use of this report. Only the Client is authorized to permit copying or distribution of this report and then only in its entirety. Any use of the Intertek name or one of its marks for the sale or advertisement of the tested material, product or service must first be approved in writing by Intertek. The observations and test results in this report are relevant only to the sample tested. This report by itself does not imply that the material, product, or service is or has ever been under an Intertek certification program. |
| Note 2:                    | When determining the test conclusion, the Measurement Uncertainty of test has been considered.   |

## 1.2 Additional information about the EUT

The EUT is a WiFi Module with 4 Antennas. 4 antennas can be used for WiFi 5GHz band and 2.4GHz band. When product operates on SISO mode 802.11a/n/ac mode (5.2/5.8G band), only one antenna(Ant1) is used for transmitting according the rationale that the receiver sensitivity has meet internal limit valve. When product operates on MIMO mode (4Tx), Ant1 to Ant4 will transmit simultaneously.

For more detail features, please refer to User's description as file name “descri.pdf”.

## 1.3 Antenna description (15.203)

The EUT uses Integral Antenna which in accordance to Section 15.203 is considered sufficient to comply with the provisions of this section.

## 1.4 Peripherals equipment

| Description | Manufacturer | Model No.         |
|-------------|--------------|-------------------|
| Laptop      | HP           | Compaq 2510p      |
| Adapter     | N/A          | GAC-002           |
| HDMI Cable  | N/A          | 1.5m (Unshielded) |

## 2. Test specifications

### 2.1 Test standard

The EUT was performed according to the procedures in FCC Part 15 E, Section 15.203, 15.207, 15.209, 15.407 and ANSI C63.10/2013, method of measurement: KDB 789033.

The test of radiated measurements according to FCC Part 15 Section 15.33(a) had been conducted and the field strength of this frequency band was all meet limit requirement, thus we evaluate the EUT pass the specified test.

The AC power conducted emissions was investigated over the frequency range from 0.15 MHz to 30 MHz using a receiver bandwidth of 9 kHz (15.207 paragraph).

Radiated emissions were investigated cover the frequency range from 9KHz to 30MHz using a receiver RBW of 9kHz, from 30 MHz to 1000 MHz using a receiver RBW of 120 kHz record QP reading, and the frequency over 1 GHz using a spectrum analyzer RBW of 1 MHz, VBW of 3MHz, Detector=Peak record for Peak reading, RBW of 1 MHz, VBW of 3MHz, Detector=RMS record for Average reading recorded on the report.

The EUT setup configurations please refer to the photo of radiated setup photos.pdf & conducted setup photos.pdf.

## 2.2 Operation mode

The EUT was supplied by adapter with 5.0Vdc, 1.5A and it was run in TX mode that was controlled by client provided RF testing program.

The EUT was transmitted continuously during the test. The worst case test result was showed in the report.

With individual verifying, the maximum output power was found at 6 Mbps data rate for 802.11a mode, 6.5 Mbps data rate for 802.11n-HT20 mode, 13.5 Mbps data rate for 802.11n-HT40 mode, 29.3Mbps data rate for 802.11ac. The final tests were executed under these conditions and recorded in this report individually.

### **Table for Parameters of Test Software Setting**

During testing, Channel & Power Controlling Software provided by the customer was used to control the operating channel as well as the output power level. The RF output power selection is for the setting of RF output power expected by the customer and is going to be fixed on the firmware of the final end product.

### 3. Maximum Output Power test (FCC 15.407)

#### 3.1 Operating environment

Temperature: 25 °C  
 Relative Humidity: 50 %  
 Atmospheric Pressure: 1023 hPa

#### 3.2 Test setup & procedure

The power output per FCC §15.407(a) was measured on the EUT using a 50 ohm SMA cable connected to Power Meter and the measurement method refer to 789033 D02. Power was read directly and cable loss correction (0.5dB) was added to the reading to obtain power at the EUT antenna terminals.

#### 3.3 Limit

| Operating Frequency (MHz) | Max Conducted TX Power                      | Max EIRP                                    |
|---------------------------|---|---|
| 5150~5250                 | * <sub>1</sub> 30dBm (1W) for master device | * <sub>2</sub> 4W (36dBm) with 6dBi antenna |
|                           | 24dBm (250mW) for client device             |   |
| 5725~5850                 | * <sub>1</sub> 30dBm (1W)                   | * <sub>2</sub> 4W (36dBm) with 6dBi antenna |

Remark: \*<sub>1</sub> The device declare as Master device.

- \*<sub>2</sub> 1).Tx Power Reduction (dBm-by-dBi) required when antenna exceeds 6dBi.
- 2). For MIMO system of 802.11n/ac, total power is calculated by combining the output power of each antenna according to KDB662911.
- 3). 5.2/5.8G band Ant: -3.5dBi
- 4). In MIMO (4Tx), Ant1+Ant2+Ant3+Ant4 Directional gain = GANT + 10 log(N)  
 dBi = -3.5 + 10 log(4) = 2.5 dBi < 6 dBi.



### 3.4 Measured data of Maximum Output Power test results

#### 5150 MHz ~ 5250 MHz

#### Max Conducted TX Power

SISO Mode, Ant1

| Mode          | Channel | Data Rate (Mbps) | Output Power (dBm) | Limit (dBm) |
|---------------|---------|------------------|--------------------|-------------|
| 802.11a       | 36      | 6                | 19.0               | 30          |
|               | 40      |                  | 19.0               | 30          |
|               | 48      |                  | 19.2               | 30          |
| 802.11n-HT20  | 36      | 6.5              | 19.2               | 30          |
|               | 40      |                  | 19.2               | 30          |
|               | 48      |                  | 19.3               | 30          |
| 802.11n-HT40  | 38      | 13.5             | 19.1               | 30          |
|               | 46      |                  | 19.7               | 30          |
| 802.11ac-HT20 | 36      | 6.5              | 19.2               | 30          |
|               | 40      |                  | 19.6               | 30          |
|               | 48      |                  | 19.9               | 30          |
| 802.11ac-HT40 | 38      | 13.5             | 20.6               | 30          |
|               | 46      |                  | 20.4               | 30          |
| 802.11ac-HT80 | 42      | 29.3             | 19.4               | 30          |

MIMO Mode, Ant1+Ant2+Ant3+Ant4

| Mode          | Channel 1 | Data Rate (Mbps) | Output Power (dBm) |      |      |      |       | Limit (dBm) |
|---------------|-----------|------------------|--------------------|------|------|------|-------|-------------|
|               |           |                  | Ant1               | Ant2 | Ant3 | Ant4 | Total |             |
| 802.11n-HT20  | 36        | 26               | 19.2               | 19.0 | 19.2 | 19.3 | 25.2  | 30          |
|               | 40        |                  | 19.2               | 19.0 | 19.0 | 19.1 | 25.1  | 30          |
|               | 48        |                  | 19.3               | 19.2 | 19.3 | 19.3 | 25.3  | 30          |
| 802.11n-HT40  | 38        | 54               | 19.1               | 19.1 | 19.2 | 19.2 | 25.2  | 30          |
|               | 46        |                  | 19.7               | 19.2 | 19.3 | 19.5 | 25.4  | 30          |
| 802.11ac-HT20 | 36        | 26               | 19.2               | 19.2 | 19.2 | 19.3 | 25.2  | 30          |
|               | 40        |                  | 19.6               | 19.3 | 19.4 | 19.4 | 25.4  | 30          |
|               | 48        |                  | 19.9               | 19.0 | 19.5 | 19.0 | 25.4  | 30          |
| 802.11ac-HT40 | 38        | 54               | 20.6               | 20.0 | 20.6 | 20.0 | 26.3  | 30          |
|               | 46        |                  | 20.4               | 20.1 | 20.1 | 20.0 | 26.2  | 30          |
| 802.11ac-HT80 | 42        | 117.2            | 19.4               | 19.0 | 19.0 | 19.1 | 25.1  | 30          |

Max EIRP  
 SISO Mode, Ant1

| Mode          | Channel | Data Rate (Mbps) | Duty cycle | Output Power (dBm) | Gain (dBi) | E.I.R.P (dBm) | Limit (dBm) |
|---------------|---------|------------------|------------|--------------------|------------|---------------|-------------|
| 802.11a       | 36      | 6                | 99%        | 19.0               | -3.5       | 15.5          | 36          |
|               | 40      |                  |            | 19.0               | -3.5       | 15.5          | 36          |
|               | 48      |                  |            | 19.2               | -3.5       | 15.7          | 36          |
| 802.11n-HT20  | 36      | 6.5              | 99%        | 19.2               | -3.5       | 15.7          | 36          |
|               | 40      |                  |            | 19.2               | -3.5       | 15.7          | 36          |
|               | 48      |                  |            | 19.3               | -3.5       | 15.8          | 36          |
| 802.11n-HT40  | 38      | 13.5             | 99%        | 19.1               | -3.5       | 15.6          | 36          |
|               | 46      |                  |            | 19.7               | -3.5       | 16.2          | 36          |
| 802.11ac-HT20 | 36      | 6.5              | 99%        | 19.2               | -3.5       | 15.7          | 36          |
|               | 40      |                  |            | 19.6               | -3.5       | 16.1          | 36          |
|               | 48      |                  |            | 19.9               | -3.5       | 16.4          | 36          |
| 802.11ac-HT40 | 38      | 13.5             | 99%        | 20.6               | -3.5       | 17.1          | 36          |
|               | 46      |                  |            | 20.4               | -3.5       | 16.9          | 36          |
| 802.11ac-HT80 | 42      | 29.3             | 99%        | 19.4               | -3.5       | 15.9          | 36          |

MIMO Mode, Ant1+Ant2+Ant3+Ant4

| Mode          | Channel | Data Rate (Mbps) | Duty cycle | Output Power (dBm) |      |      |      |       | Gain (dBi) | E.I.R.P (dBm) | Limit (dBm) |
|---------------|---------|------------------|------------|--------------------|------|------|------|-------|------------|---------------|-------------|
|               |         |                  |            | Ant1               | Ant2 | Ant3 | Ant4 | Total |            |               |             |
| 802.11n-HT20  | 36      | 26               | 99%        | 19.2               | 19.0 | 19.2 | 19.3 | 25.2  | -3.5       | 21.7          | 36          |
|               | 40      |                  |            | 19.2               | 19.0 | 19.0 | 19.1 | 25.1  | -3.5       | 21.6          | 36          |
|               | 48      |                  |            | 19.3               | 19.2 | 19.3 | 19.3 | 25.3  | -3.5       | 21.8          | 36          |
| 802.11n-HT40  | 38      | 54               | 99%        | 19.1               | 19.1 | 19.2 | 19.2 | 25.2  | -3.5       | 21.7          | 36          |
|               | 46      |                  |            | 19.7               | 19.2 | 19.3 | 19.5 | 25.4  | -3.5       | 21.9          | 36          |
| 802.11ac-HT20 | 36      | 26               | 99%        | 19.2               | 19.2 | 19.2 | 19.3 | 25.2  | -3.5       | 21.7          | 36          |
|               | 40      |                  |            | 19.6               | 19.3 | 19.4 | 19.4 | 25.4  | -3.5       | 21.9          | 36          |
|               | 48      |                  |            | 19.9               | 19.0 | 19.5 | 19.0 | 25.4  | -3.5       | 21.9          | 36          |
| 802.11ac-HT40 | 38      | 54               | 99%        | 20.6               | 20.0 | 20.6 | 20.0 | 26.3  | -3.5       | 22.8          | 36          |
|               | 46      |                  |            | 20.4               | 20.1 | 20.1 | 20.0 | 26.2  | -3.5       | 22.7          | 36          |
| 802.11ac-HT80 | 42      | 117.2            | 99%        | 19.4               | 19.0 | 19.0 | 19.1 | 25.1  | -3.5       | 19.6          | 36          |

**5725 MHz ~ 5850 MHz**

**Max Conducted TX Power**

SISO Mode, Ant1

| Mode          | Channel | Data Rate (Mbps) | Output Power (dBm) | Limit (dBm) |
|---------------|---------|------------------|--------------------|-------------|
| 802.11a       | 149     | 6                | 19.5               | 30          |
|               | 157     |                  | 19.1               | 30          |
|               | 165     |                  | 19.0               | 30          |
| 802.11n-HT20  | 149     | 6.5              | 19.8               | 30          |
|               | 157     |                  | 19.6               | 30          |
|               | 165     |                  | 19.2               | 30          |
| 802.11n-HT40  | 151     | 13.5             | 19.2               | 30          |
|               | 159     |                  | 19.9               | 30          |
| 802.11ac-HT20 | 149     | 6.5              | 19.8               | 30          |
|               | 157     |                  | 19.5               | 30          |
|               | 165     |                  | 19.4               | 30          |
| 802.11ac-HT40 | 151     | 13.5             | 19.8               | 30          |
|               | 159     |                  | 19.7               | 30          |
| 802.11ac-HT80 | 155     | 29.3             | 19.5               | 30          |

MIMO Mode, Ant1+Ant2+Ant3+Ant4

| Mode          | Channel | Data Rate (Mbps) | Output Power (dBm) |      |      |      |       | Limit (dBm) |
|---------------|---------|------------------|--------------------|------|------|------|-------|-------------|
|               |         |                  | Ant1               | Ant2 | Ant3 | Ant4 | Total |             |
| 802.11n-HT20  | 149     | 26               | 19.8               | 17.7 | 17.6 | 17.7 | 24.3  | 30          |
|               | 157     |                  | 19.6               | 16.6 | 16.5 | 16.6 | 23.6  | 30          |
|               | 165     |                  | 19.2               | 17.4 | 17.5 | 19.2 | 24.4  | 30          |
| 802.11n-HT40  | 151     | 54               | 19.2               | 17.0 | 17.5 | 18.2 | 24.4  | 30          |
|               | 159     |                  | 19.9               | 17.9 | 17.0 | 17.9 | 24.1  | 30          |
| 802.11ac-HT20 | 149     | 26               | 19.8               | 17.8 | 17.5 | 17.8 | 24.3  | 30          |
|               | 157     |                  | 19.5               | 17.6 | 17.6 | 18.5 | 24.4  | 30          |
|               | 165     |                  | 19.4               | 18.6 | 17.6 | 19.4 | 24.8  | 30          |
| 802.11ac-HT40 | 151     | 54               | 19.8               | 19.1 | 18.1 | 19.8 | 25.3  | 30          |
|               | 159     |                  | 19.7               | 18.2 | 18.5 | 19.7 | 25.1  | 30          |
| 802.11ac-HT80 | 155     | 117.2            | 19.5               | 18.3 | 17.3 | 19.5 | 24.8  | 30          |

Max EIRP

SISO Mode, Ant1

| Mode         | Channel | Data Rate (Mbps) | Duty cycle | Output Power (dBm) | Gain (dBi) | E.I.R.P (dBm) | Limit (dBm) |
|--------------|---------|------------------|------------|--------------------|------------|---------------|-------------|
| 802.11a      | 149     | 6                | 99%        | 19.5               | -3.5       | 16.0          | 36          |
|              | 157     |                  |            | 19.1               | -3.5       | 15.6          | 36          |
|              | 165     |                  |            | 19.0               | -3.5       | 15.5          | 36          |
| 802.11n-HT20 | 149     | 6.5              | 99%        | 19.8               | -3.5       | 16.3          | 36          |
|              | 157     |                  |            | 19.6               | -3.5       | 16.1          | 36          |
|              | 165     |                  |            | 19.2               | -3.5       | 15.7          | 36          |
| 802.11n-HT40 | 151     | 13.5             | 99%        | 19.2               | -3.5       | 15.7          | 36          |
|              | 159     |                  |            | 19.9               | -3.5       | 16.4          | 36          |
| 802.11n-HT20 | 149     | 6.5              | 99%        | 19.8               | -3.5       | 16.3          | 36          |
|              | 157     |                  |            | 19.5               | -3.5       | 16.0          | 36          |
|              | 165     |                  |            | 19.4               | -3.5       | 15.9          | 36          |
| 802.11n-HT40 | 151     | 13.5             | 99%        | 19.8               | -3.5       | 16.3          | 36          |
|              | 159     |                  |            | 19.7               | -3.5       | 16.2          | 36          |
| 802.11ac     | 155     | 29.3             | 99%        | 19.5               | -3.5       | 16.0          | 36          |

MIMO Mode, Ant1+Ant2+Ant3+Ant4

| Mode          | Channel | Data Rate (Mbps) | Duty cycle | Output Power (dBm) |      |      |      |       | Gain (dBi) | E.I.R.P (dBm) | Limit (dBm) |
|---------------|---------|------------------|------------|--------------------|------|------|------|-------|------------|---------------|-------------|
|               |         |                  |            | Ant1               | Ant2 | Ant3 | Ant4 | Total |            |               |             |
| 802.11n-HT20  | 149     | 26               | 99%        | 19.8               | 17.7 | 17.6 | 17.7 | 24.3  | -3.5       | 20.6          | 36          |
|               | 157     |                  |            | 19.6               | 16.6 | 16.5 | 16.6 | 23.6  | -3.5       | 20.1          | 36          |
|               | 165     |                  |            | 19.2               | 17.4 | 17.5 | 19.2 | 24.4  | -3.5       | 20.9          | 36          |
| 802.11n-HT40  | 151     | 54               | 99%        | 19.2               | 17.0 | 17.5 | 18.2 | 24.4  | -3.5       | 20.9          | 36          |
|               | 159     |                  |            | 19.9               | 17.9 | 17.0 | 17.9 | 24.1  | -3.5       | 20.6          | 36          |
| 802.11ac-HT20 | 149     | 26               | 99%        | 19.8               | 17.8 | 17.5 | 17.8 | 24.3  | -3.5       | 20.8          | 36          |
|               | 157     |                  |            | 19.5               | 17.6 | 17.6 | 18.5 | 24.4  | -3.5       | 20.9          | 36          |
|               | 165     |                  |            | 19.4               | 18.6 | 17.6 | 19.4 | 24.8  | -3.5       | 21.3          | 36          |
| 802.11ac-HT40 | 151     | 54               | 99%        | 19.8               | 19.1 | 18.1 | 19.8 | 25.3  | -3.5       | 21.8          | 36          |
|               | 159     |                  |            | 19.7               | 18.2 | 18.5 | 19.7 | 25.1  | -3.5       | 21.6          | 36          |
| 802.11ac-HT80 | 155     | 117.2            | 99%        | 19.5               | 18.3 | 17.3 | 19.5 | 24.8  | -3.5       | 21.3          | 36          |

#### 4. Power Spectrum Density test (FCC 15.407)

##### 4.1 Operating environment

Temperature: 25 °C  
 Relative Humidity: 50 %  
 Atmospheric Pressure: 1023 hPa

##### 4.2 Test setup & procedure

###### Method of Measurement:

The power spectrum density per FCC §15.407(a) was measured from the antenna port of the EUT using a 50 ohm spectrum analyzer with the resolution bandwidth set at 1MHz/500KHz, the video bandwidth set at 3 MHz/2MHz (measurement method refer to KDB 789033 D02). Power spectrum density was read directly and cable loss (0.5 dB) reading to obtain power at the EUT antenna terminals.

For MIMO system 4Tx the antenna ports is checked, the worst case power density is calculated from the method of Measure by adding  $10\text{Log}(2)/10\text{Log}(3)$  according KDB662911.

##### 4.3 Limit

| Operating Frequency (MHz) | Max Conducted Power Spectral Density          |
|---------------------------|---|
| 5150~5250                 | * <sub>1</sub> 17dBm/MHz for master device    |
|                           | 11dBm/MHz for mobile/portable client device   |
| 5725~5850                 | * <sub>1</sub> 30dBm/500KHz for master device |

Remark: \*<sub>1</sub> The device declare as Master device.

- 1). Tx Power Reduction (dBm-by-dBi) required when antenna exceeds 6dBi.
- 2). 5.2/5.8G band Ant: -3.5dBi
- 3). In MIMO (4Tx), Ant1+Ant2+Ant3+Ant4 Directional gain = GANT + 10 log(N)  
 $\text{dBi} = -3.5 + 10 \log(4) = 2.5\text{dBi} < 6\text{dBi}$

#### 4.4 Measured data of Power Spectrum Density test results

##### 5150 MHz ~ 5250 MHz

SISO Mode, Ant1

| Mode          | Channel | Data Rate (Mbps) | PSD (dBm/MHz) | Limit (dBm/MHz) |
|---------------|---------|------------------|---------------|-----------------|
| 802.11a       | 36      | 6                | 7.87          | 17              |
|               | 40      |                  | 7.44          | 17              |
|               | 48      |                  | 7.96          | 17              |
| 802.11n-HT20  | 36      | 6.5              | 8.64          | 17              |
|               | 40      |                  | 8.49          | 17              |
|               | 48      |                  | 8.34          | 17              |
| 802.11n-HT40  | 38      | 13.5             | 4.38          | 17              |
|               | 46      |                  | 4.48          | 17              |
| 802.11ac-HT20 | 36      | 6.5              | 8.50          | 17              |
|               | 40      |                  | 8.32          | 17              |
|               | 48      |                  | 8.61          | 17              |
| 802.11ac-HT40 | 38      | 13.5             | 5.02          | 17              |
|               | 46      |                  | 4.92          | 17              |
| 802.11ac-HT80 | 42      | 29.3             | 1.88          | 17              |

MIMO Mode, Ant1+Ant2+Ant3+Ant4

| Mode          | Channel | Data Rate (Mbps) | PSD (dBm/MHz) |       |       |       |       | Limit (dBm/MHz) |
|---------------|---------|------------------|---------------|-------|-------|-------|-------|-----------------|
|               |         |                  | Ant1          | Ant2  | Ant3  | Ant4  | Total |                 |
| 802.11n-HT20  | 36      | 26               | 7.06          | 7.94  | 5.30  | 3.90  | 12.34 | 17              |
|               | 40      |                  | 7.50          | 8.01  | 4.61  | 3.33  | 12.30 | 17              |
|               | 48      |                  | 7.51          | 8.04  | 4.76  | 3.87  | 12.41 | 17              |
| 802.11n-HT40  | 38      | 54               | 0.56          | 2.95  | 0.74  | 1.59  | 7.59  | 17              |
|               | 46      |                  | 0.69          | 3.10  | 0.01  | 0.50  | 7.27  | 17              |
| 802.11ac-HT20 | 36      | 26               | 7.16          | 7.95  | 5.58  | 4.64  | 12.54 | 17              |
|               | 40      |                  | 4.31          | 5.65  | 4.60  | 4.04  | 10.72 | 17              |
|               | 48      |                  | 3.89          | 5.36  | 4.34  | 3.58  | 10.37 | 17              |
| 802.11ac-HT40 | 38      | 54               | 0.31          | 3.46  | 1.25  | 1.91  | 7.91  | 17              |
|               | 46      |                  | 0.49          | 3.65  | 0.67  | 0.81  | 7.64  | 17              |
| 802.11ac-HT80 | 42      | 117.2            | -2.17         | -0.70 | -1.78 | -1.40 | 4.54  | 17              |

**5725 MHz ~ 5850 MHz**

SISO Mode, Ant1

| Mode          | Channel | Data Rate (Mbps) | PSD (dBm/500KHz) | Limit (dBm/500KHz) |
|---------------|---------|------------------|------------------|--------------------|
| 802.11a       | 149     | 6                | 5.96             | 30                 |
|               | 157     |                  | 5.74             | 30                 |
|               | 165     |                  | 5.58             | 30                 |
| 802.11n-HT20  | 149     | 6.5              | 6.13             | 30                 |
|               | 157     |                  | 6.13             | 30                 |
|               | 165     |                  | 5.61             | 30                 |
| 802.11n-HT40  | 151     | 13.5             | 2.13             | 30                 |
|               | 159     |                  | 1.98             | 30                 |
| 802.11ac-HT20 | 149     | 6.5              | 5.92             | 30                 |
|               | 157     |                  | 5.84             | 30                 |
|               | 165     |                  | 6.00             | 30                 |
| 802.11ac-HT40 | 151     | 13.5             | 2.14             | 30                 |
|               | 159     |                  | 2.06             | 30                 |
| 802.11ac-HT80 | 155     | 29.3             | -1.43            | 30                 |

MIMO Mode, Ant1+Ant2+Ant3+Ant4

| Mode          | Channel | Data Rate (Mbps) | PSD (dBm/500KHz) |       |       |       |       | Limit (dBm/500KHz) |
|---------------|---------|------------------|------------------|-------|-------|-------|-------|--------------------|
|               |         |                  | Ant1             | Ant2  | Ant3  | Ant4  | Total |                    |
| 802.11n-HT20  | 149     | 26               | 1.54             | 2.71  | 2.31  | 0.38  | 7.84  | 30                 |
|               | 157     |                  | 1.37             | 2.86  | 2.45  | 0.49  | 7.91  | 30                 |
|               | 165     |                  | 1.66             | 1.95  | 2.35  | 0.50  | 7.69  | 30                 |
| 802.11n-HT40  | 151     | 54               | -2.67            | -0.53 | -1.28 | -2.78 | 4.31  | 30                 |
|               | 159     |                  | -2.19            | -1.38 | -1.44 | -2.26 | 4.22  | 30                 |
| 802.11ac-HT20 | 149     | 26               | 1.93             | 1.40  | 2.48  | 1.51  | 7.87  | 30                 |
|               | 157     |                  | 1.99             | 1.88  | 2.32  | 1.56  | 7.97  | 30                 |
|               | 165     |                  | 2.04             | 1.89  | 2.38  | 1.60  | 8.00  | 30                 |
| 802.11ac-HT40 | 151     | 54               | -2.21            | -0.73 | -0.86 | -2.19 | 4.67  | 30                 |
|               | 159     |                  | -1.90            | -0.81 | -0.69 | -1.92 | 4.73  | 30                 |
| 802.11ac-HT80 | 155     | 117.2            | -4.90            | -4.45 | -4.70 | -5.39 | 1.17  | 30                 |

Please refer the graph of “PSD.pdf”.

## 5. Minimum 6 dB RF Bandwidth (FCC 15.407)

### 5.1 Operating environment

Temperature: 25 °C  
 Relative Humidity: 50 %  
 Atmospheric Pressure: 1023 hPa

### 5.2 Test setup & procedure

The Minimum 6 dB RF Bandwidth per 789033 D02 was measured from the antenna port of the EUT using a 50 ohm spectrum analyzer with the resolution bandwidth set at 100KHz, and set the video bandwidth (VBW)  $\geq 3 \times$  RBW. For each RF output channel investigated, the spectrum analyzer center frequency was set to the channel carrier. A PEAK output reading was taken, a DISPLAY line was drawn 6 dB lower than PEAK level. The 6dB bandwidth was determined from where the channel output spectrum intersected the display line.

#### For 26dB down Emission Bandwidth

The 26dB down Emission Bandwidth per 789033 D02 was measured from the antenna port of the EUT using a 50 ohm spectrum analyzer with the resolution bandwidth set RBW = approximately 1% of the emission bandwidth. Set the VBW  $>$  RBW, Detector = Peak, Trace mode = max hold (Measure the maximum width of the emission that is 26 dB down from the maximum of the emission. Compare this with the RBW setting of the analyzer. Readjust RBW and repeat measurement as needed until the RBW/EBW ratio is approximately 1%).

#### For 99% Occupied Bandwidth

The 99% Occupied Bandwidth per 789033 D02 was measured from the antenna port of the EUT using a 50 ohm spectrum analyzer with the resolution bandwidth set center frequency to the nominal EUT channel center frequency, set span = 1.5 times to 5.0 times the OBW, set RBW = 1 % to 5 % of the OBW, set VBW  $\geq 3 \times$  RBW, The 99% occupied bandwidth was determined from where the channel output spectrum intersected the display line.

### 5.3 Limit

| Operating Frequency (MHz) | Minimum 6 dB RF Bandwidth Limit |
|---------------------------|---------------------------------|
| 5150~5250                 | N/A                             |
| 5725~5850                 | $\geq 500\text{KHz}$            |

**Note: 99% Occupied Bandwidth within the U-NII-1 band and 26dB Emission Bandwidth for reference.**



### 5.4 Measured data of Minimum 6 dB RF Bandwidth test results

SISO Mode, Ant1

| Mode          | Channel | Data Rate (Mbps) | Result |
|---------------|---------|------------------|--------|
| 802.11a       | 157     | 6                | Pass   |
| 802.11n-HT20  | 157     | 6.5              | Pass   |
| 802.11n-HT40  | 159     | 13.5             | Pass   |
| 802.11ac-HT20 | 157     | 6.5              | Pass   |
| 802.11ac-HT40 | 159     | 13.5             | Pass   |
| 802.11ac-HT80 | 155     | 29.3             | Pass   |

MIMO Mode, Ant1+Ant2+Ant3+Ant4

Ant1

| Mode          | Channel | Data Rate (Mbps) | Result |
|---------------|---------|------------------|--------|
| 802.11n-HT20  | 157     | 26               | Pass   |
| 802.11n-HT40  | 159     | 54               | Pass   |
| 802.11ac-HT20 | 157     | 26               | Pass   |
| 802.11ac-HT40 | 159     | 54               | Pass   |
| 802.11ac-HT80 | 155     | 117.2            | Pass   |

Note:

1. Please refer the graph of “6 dB Bandwidth.pdf”.
2. For each operating mode, it is not necessary to measure the bandwidth on the high and low channels, as the measured channel bandwidth on the middle channel is at least 150% of the minimum permitted bandwidth.
3. For multiple-input multiple-output (MIMO) systems, it is not necessary to repeat testing on the other chains, as the measured channel bandwidth on testing the middle channel exceeds the minimum permitted bandwidth by more than 50% on one transmit chain.

**6. Radiated Emission test (FCC 15.205 & 15.209 & 15.407)**

**6.1 Operating environment**

Temperature: 23 °C  
 Relative Humidity: 58 %  
 Atmospheric Pressure 1023 hPa

**6.2 Test setup & procedure**

The Diagram below shows the test setup, which is utilized to make these measurements.

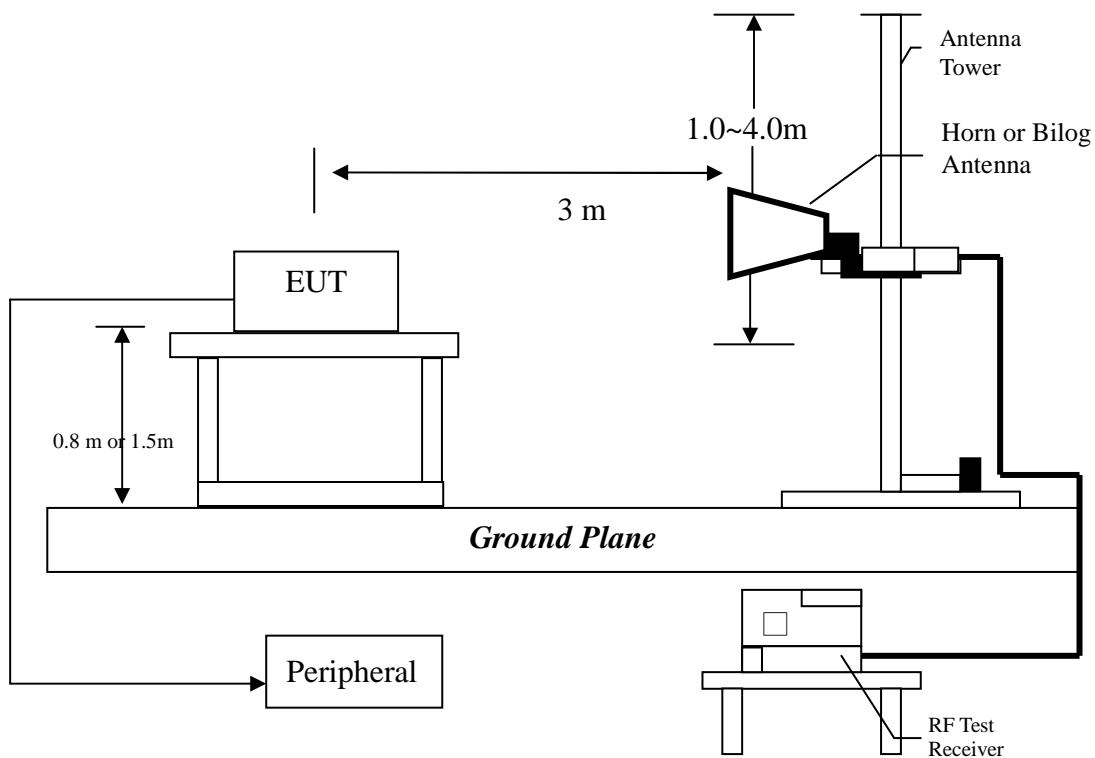

Radiated emission measurements were performed from 9KHz to tenth harmonic or 40GHz. The EUT for testing is arranged on a styrene turntable with the height of 0.8m up to 1GHz and 1.5m above 1GHz. If some peripherals apply to the EUT, the peripherals will be connected to EUT and the whole system. During the test, all cables were arranged to produce worst-case emissions. The signal is maximized through rotation. The height of antenna and polarization is changing constantly for exploring for maximum signal level. The height of antenna can be up to 4 meters and down to 1 meter.

The measurement for radiated emission will be done at the distance of three meters unless the signal level is too low to measure at that distance. In the case of the reading under noise floor, a pre-amplifier is used and/or the test is conducted at a closer distance. And then all readings are extrapolated back to the equivalent three meter reading using inverse scaling with distance.

Testing settings (refer to KDB 789033 D02)

Peak Measurements below 1GHz

- 1, Analyzer center frequency was set to the frequency of the radiated spurious emission.
- 2, Span=encompass the entire emission
- 3, RBW=120KHz
- 4, Detector=Quasi-Peak
- 5, Trace was allowed to stabilize

Peak Measurements above 1GHz

- 1, Analyzer center frequency was set to the frequency of the radiated spurious emission.
- 2, Span=encompass the entire emission
- 3, RBW=1MHz
- 4, VBW=3MHz
- 4, Detector= Peak (Max-hold)
- 5, Trace was allowed to stabilize

Average Measurements above 1GHz

- 1, Analyzer center frequency was set to the frequency of the radiated spurious emission.
- 2, Span=encompass the entire emission
- 3, RBW=1MHz
- 4, VBW=3MHz
- 4, Detector= RMS (Max-hold)
- 5, Trace was allowed to stabilize

### 6.3 Limit

The spurious Emission shall test through the 10th harmonic or 40GHz (whichever is lower). In addition, radiated emissions which fall in the restricted bands, as defined in §15.205(a), must also comply with the radiated emission limits specified in §15.209(a).

#### Notes:

- 1, All emission out-side of the 5.15-5.35GHz & 5.47-5.725GHz band shall not exceed an EIRP of -27dBm/MHz (68.2dBuV/m, test distance: 3 meter), for band 5.725-5.85GHz shall not exceed an  $\leq$ -17dBm/MHz (78.2dBuV/m, test distance: 3 meter) within 5715-5725MHz and 5850-5860MHz,  $\leq$ -27dBm/MHz (68.2dBuV/m, test distance: 3 meter) outside 5715-5860MHz.
- 2, The spectrum is measured from 9KHz to the 10<sup>th</sup> harmonic of the fundamental frequency of the transmitter using QP detector below 1GHz, above 1GHz, average & peak measurements were taken using for test. The worst-case emission are reported however emission whose levels were not within 20dB of the respective limited were not reported.
- 3, The test was performed on EUT under 802.11a/n-HT20/40/ac-HT20/40/80 continuously transmitting mode. Simultaneous transmitting was considered during the testing.

## Field Strength Calculation

The field strength is calculated by adding the reading on the Spectrum Analyzer to the factors associated with preamplifiers (if any), antennas, cables, pulse desensitization and average factors (when specified limit is in average and measurements are made with peak detectors). A sample calculation is included below.

$$FS = RA + AF + CF - AG + PD$$

Where FS = Field Strength in dB $\mu$ V/m  
RA = Receiver Amplitude (including preamplifier) in dB $\mu$ V  
CF = Cable Attenuation Factor in dB  
AF = Antenna Factor in dB  
AG = Amplifier Gain in dB  
PD = Pulse Desensitization in dB

In the radiated emission table which follows, the reading shown on the data table may reflect the preamplifier gain. An example of the calculations, where the reading does not reflect the preamplifier gain, follows:

$$FS = RA + AF + CF - AG + PD$$

### Example

Assume a receiver reading of 62.0 dB $\mu$ V is obtained. The antenna factor of 7.4 dB and cable factor of 1.6 dB is added. The amplifier gain of 29 dB is subtracted. The pulse desensitization factor of the spectrum analyzer was 0 dB. The net field strength for comparison to the appropriate emission limit is 32 dB $\mu$ V/m. This value in dB $\mu$ V/m was converted to its corresponding level in  $\mu$ V/m.

$$\begin{aligned} RA &= 62.0 \text{ dB}\mu\text{V} \\ AF &= 7.4 \text{ dB} \\ CF &= 1.6 \text{ dB} \\ AG &= 29.0 \text{ dB} \\ PD &= 0 \text{ dB} \\ FS &= 62 + 7.4 + 1.6 - 29 + 0 = 42 \text{ dB}\mu\text{V/m} \end{aligned}$$

$$\text{Level in mV/m} = \text{Common Antilogarithm} [(42 \text{ dB}\mu\text{V/m})/20] = 125.9 \mu\text{V/m}$$

## 6.4 Radiated spurious emission test data

### 6.4.1 Measurement results: frequencies equal to or less than 1 GHz

The worst case occurred at 802.11n-HT40, MIMO, 4Tx, Channel 38/54Mbps

| Polarization | Frequency (MHz) | Reading (dB $\mu$ V) | Pre-Amp Gain (dB) | Antenna Factor (dB) | Net at 3m (dB $\mu$ V/m) | Limit at 3m (dB $\mu$ V/m) | Margin (dB) |
|--------------|-----------------|----------------------|-------------------|---------------------|--------------------------|----------------------------|-------------|
| Horizontal   | 30.970          | 23.4                 | 20.0              | 17.9                | 21.3                     | 40.0                       | -18.7       |
| Horizontal   | 441.765         | 38.0                 | 20.0              | 11.3                | 29.3                     | 43.5                       | -14.2       |
| Horizontal   | 638.220         | 22.3                 | 20.0              | 29.7                | 32.0                     | 46.0                       | -14.0       |
| Vertical     | 38.245          | 31.2                 | 20.0              | 13.3                | 24.5                     | 40.0                       | -15.5       |
| Vertical     | 40.680          | 38.9                 | 20.0              | 8.6                 | 27.5                     | 40.0                       | -12.5       |
| Vertical     | 177.925         | 17.5                 | 20.0              | 28.0                | 25.5                     | 43.5                       | -18.0       |

### 6.4.2 Measurement results: frequency above 1GHz

Test Condition : 802.11a, SISO, Ant1, Channel 36/6Mbps

| Polarization | Frequency (MHz) | Reading (dBμV) | Pre-Amp Gain (dB) | Antenna Factor (dB) | Net at 3m (dBμV/m) | Peak Limit at 3m (dBμV/m) | Margin (dB) |
|--------------|-----------------|----------------|-------------------|---------------------|--------------------|---------------------------|-------------|
| Horizontal   | 10360.000       | 59.7           | 36.3              | 38.9                | 62.3               | 68.2                      | -5.9        |
| Horizontal   | 15540.000       | 56.6           | 34.7              | 41.0                | 62.9               | 68.2                      | -5.3        |
| Horizontal   | 5149.300        | 58.8           | 36.1              | 35.5                | 58.2               | 68.2                      | -10.0       |

| Polarization | Frequency (MHz) | Reading (dBμV) | Pre-Amp Gain (dB) | Antenna Factor (dB) | Net at 3m (dBμV/m) | Peak Limit at 3m (dBμV/m) | Margin (dB) |
|--------------|-----------------|----------------|-------------------|---------------------|--------------------|---------------------------|-------------|
| Horizontal   | *15540          | 44.2           | 34.7              | 41.0                | 50.5               | 54.0                      | -3.5        |
| Horizontal   | *5149.3         | 50.6           | 36.1              | 35.5                | 50.0               | 54.0                      | -4.0        |

Test Condition : 802.11a, SISO, Ant1, Channel 40/6Mbps

| Polarization | Frequency (MHz) | Reading (dBμV) | Pre-Amp Gain (dB) | Antenna Factor (dB) | Net at 3m (dBμV/m) | Peak Limit at 3m (dBμV/m) | Margin (dB) |
|--------------|-----------------|----------------|-------------------|---------------------|--------------------|---------------------------|-------------|
| Horizontal   | 10400.000       | 59.2           | 36.3              | 38.9                | 61.8               | 68.2                      | -6.4        |
| Horizontal   | 15600.000       | 53.9           | 34.7              | 41.0                | 60.2               | 68.2                      | -8.0        |

| Polarization | Frequency (MHz) | Reading (dBμV) | Pre-Amp Gain (dB) | Antenna Factor (dB) | Net at 3m (dBμV/m) | Peak Limit at 3m (dBμV/m) | Margin (dB) |
|--------------|-----------------|----------------|-------------------|---------------------|--------------------|---------------------------|-------------|
| Horizontal   | *15600          | 44.8           | 34.7              | 41.0                | 51.1               | 54.0                      | -2.9        |

Test Condition : 802.11a, SISO, Ant1, Channel 48/6Mbps

| Polarization | Frequency (MHz) | Reading (dBμV) | Pre-Amp Gain (dB) | Antenna Factor (dB) | Net at 3m (dBμV/m) | Peak Limit at 3m (dBμV/m) | Margin (dB) |
|--------------|-----------------|----------------|-------------------|---------------------|--------------------|---------------------------|-------------|
| Horizontal   | 10480.000       | 57.6           | 36.3              | 38.9                | 60.2               | 68.2                      | -8.0        |
| Horizontal   | 15720.000       | 51.8           | 34.7              | 41.0                | 58.1               | 68.2                      | -10.1       |
| Horizontal   | 5351.780        | 58.6           | 35.9              | 36.4                | 59.1               | 68.2                      | -9.1        |

| Polarization | Frequency (MHz) | Reading (dB $\mu$ V) | Pre-Amp Gain (dB) | Antenna Factor (dB) | Net at 3m (dB $\mu$ V/m) | Peak Limit at 3m (dB $\mu$ V/m) | Margin (dB) |
|--------------|-----------------|----------------------|-------------------|---------------------|--------------------------|---------------------------------|-------------|
| Horizontal   | *15720.000      | 44.5                 | 34.7              | 41.0                | 50.8                     | 54.0                            | -3.2        |
| Horizontal   | *5351.780       | 49.7                 | 35.9              | 36.4                | 50.2                     | 54.0                            | -3.8        |

Test Condition : 802.11n-HT20, SISO, Ant1, Channel 36/6.5Mbps

| Polarization | Frequency (MHz) | Reading (dB $\mu$ V) | Pre-Amp Gain (dB) | Antenna Factor (dB) | Net at 3m (dB $\mu$ V/m) | Peak Limit at 3m (dB $\mu$ V/m) | Margin (dB) |
|--------------|-----------------|----------------------|-------------------|---------------------|--------------------------|---------------------------------|-------------|
| Horizontal   | 10360.000       | 58.7                 | 36.3              | 38.9                | 61.3                     | 68.2                            | -6.9        |
| Horizontal   | 15540.000       | 56.5                 | 34.7              | 41.0                | 62.8                     | 68.2                            | -5.4        |
| Horizontal   | 5148.569        | 59.1                 | 36.1              | 35.5                | 58.5                     | 68.2                            | -9.7        |

| Polarization | Frequency (MHz) | Reading (dB $\mu$ V) | Pre-Amp Gain (dB) | Antenna Factor (dB) | Net at 3m (dB $\mu$ V/m) | Peak Limit at 3m (dB $\mu$ V/m) | Margin (dB) |
|--------------|-----------------|----------------------|-------------------|---------------------|--------------------------|---------------------------------|-------------|
| Horizontal   | *15540          | 40.5                 | 34.7              | 41.0                | 46.8                     | 54.0                            | -7.2        |
| Horizontal   | *5148.569       | 47.1                 | 36.1              | 35.5                | 46.5                     | 54.0                            | -7.5        |

Test Condition : 802.11n-HT20, SISO, Ant1, Channel 40/6.5Mbps

| Polarization | Frequency (MHz) | Reading (dB $\mu$ V) | Pre-Amp Gain (dB) | Antenna Factor (dB) | Net at 3m (dB $\mu$ V/m) | Peak Limit at 3m (dB $\mu$ V/m) | Margin (dB) |
|--------------|-----------------|----------------------|-------------------|---------------------|--------------------------|---------------------------------|-------------|
| Horizontal   | 10400.000       | 57.7                 | 36.3              | 38.9                | 60.3                     | 68.2                            | -7.9        |
| Horizontal   | 15600.000       | 55.1                 | 34.7              | 41.0                | 61.4                     | 68.2                            | -6.8        |

| Polarization | Frequency (MHz) | Reading (dB $\mu$ V) | Pre-Amp Gain (dB) | Antenna Factor (dB) | Net at 3m (dB $\mu$ V/m) | Peak Limit at 3m (dB $\mu$ V/m) | Margin (dB) |
|--------------|-----------------|----------------------|-------------------|---------------------|--------------------------|---------------------------------|-------------|
| Horizontal   | *15600          | 42.7                 | 34.7              | 41.0                | 49.0                     | 54.0                            | -5.0        |

Test Condition : 802.11n-HT20, SISO, Ant1, Channel 48/6.5Mbps

| Polarization | Frequency (MHz) | Reading (dB $\mu$ V) | Pre-Amp Gain (dB) | Antenna Factor (dB) | Net at 3m (dB $\mu$ V/m) | Peak Limit at 3m (dB $\mu$ V/m) | Margin (dB) |
|--------------|-----------------|----------------------|-------------------|---------------------|--------------------------|---------------------------------|-------------|
| Horizontal   | 10480.000       | 57.9                 | 36.3              | 38.9                | 60.5                     | 68.2                            | -7.7        |
| Horizontal   | 15720.000       | 56.8                 | 34.7              | 41.0                | 63.1                     | 68.2                            | -5.1        |
| Horizontal   | 5351.594        | 58.1                 | 35.9              | 36.4                | 58.6                     | 68.2                            | -9.6        |



| Polarization | Frequency (MHz) | Reading (dBμV) | Pre-Amp Gain (dB) | Antenna Factor (dB) | Net at 3m (dBμV/m) | Peak Limit at 3m (dBμV/m) | Margin (dB) |
|--------------|-----------------|----------------|-------------------|---------------------|--------------------|---------------------------|-------------|
| Horizontal   | *15720          | 40.3           | 34.7              | 41.0                | 46.6               | 54.0                      | -7.4        |
| Horizontal   | *5351.594       | 47.6           | 35.9              | 36.4                | 48.1               | 54.0                      | -5.9        |

Test Condition : 802.11n-HT20, MIMO, Ant1+2+3+4, Channel 36/26Mbps

| Polarization | Frequency (MHz) | Reading (dBμV) | Pre-Amp Gain (dB) | Antenna Factor (dB) | Net at 3m (dBμV/m) | Peak Limit at 3m (dBμV/m) | Margin (dB) |
|--------------|-----------------|----------------|-------------------|---------------------|--------------------|---------------------------|-------------|
| Horizontal   | 10360.000       | 58.0           | 36.3              | 38.9                | 60.6               | 68.2                      | -7.6        |
| Horizontal   | 15540.000       | 53.9           | 34.7              | 41.0                | 60.2               | 68.2                      | -8.0        |
| Horizontal   | 5149.470        | 58.9           | 36.1              | 35.5                | 58.3               | 68.2                      | -9.9        |

| Polarization | Frequency (MHz) | Reading (dBμV) | Pre-Amp Gain (dB) | Antenna Factor (dB) | Net at 3m (dBμV/m) | Peak Limit at 3m (dBμV/m) | Margin (dB) |
|--------------|-----------------|----------------|-------------------|---------------------|--------------------|---------------------------|-------------|
| Horizontal   | *15540          | 43.0           | 34.7              | 41.0                | 49.3               | 54.0                      | -4.7        |
| Horizontal   | *5149.47        | 47.1           | 36.1              | 35.5                | 46.5               | 54.0                      | -7.5        |

Test Condition : 802.11n-HT20, MIMO, Ant1+2+3+4, Channel 40/26Mbps

| Polarization | Frequency (MHz) | Reading (dBμV) | Pre-Amp Gain (dB) | Antenna Factor (dB) | Net at 3m (dBμV/m) | Peak Limit at 3m (dBμV/m) | Margin (dB) |
|--------------|-----------------|----------------|-------------------|---------------------|--------------------|---------------------------|-------------|
| Horizontal   | 10400.000       | 57.9           | 36.3              | 38.9                | 60.5               | 68.2                      | -7.7        |
| Horizontal   | 15600.000       | 53.3           | 34.7              | 41.0                | 59.6               | 68.2                      | -8.6        |

| Polarization | Frequency (MHz) | Reading (dBμV) | Pre-Amp Gain (dB) | Antenna Factor (dB) | Net at 3m (dBμV/m) | Peak Limit at 3m (dBμV/m) | Margin (dB) |
|--------------|-----------------|----------------|-------------------|---------------------|--------------------|---------------------------|-------------|
| Horizontal   | *15600          | 40.5           | 34.7              | 41.0                | 46.8               | 54.0                      | -7.2        |

Test Condition : 802.11n-HT20, MIMO, Ant1+2+3+4, Channel 48/26Mbps

| Polarization | Frequency (MHz) | Reading (dBμV) | Pre-Amp Gain (dB) | Antenna Factor (dB) | Net at 3m (dBμV/m) | Peak Limit at 3m (dBμV/m) | Margin (dB) |
|--------------|-----------------|----------------|-------------------|---------------------|--------------------|---------------------------|-------------|
| Horizontal   | 10480.000       | 58.8           | 36.3              | 38.9                | 61.4               | 68.2                      | -6.8        |
| Horizontal   | 15720.000       | 54.2           | 34.7              | 41.0                | 60.5               | 68.2                      | -7.7        |
| Horizontal   | 5351.562        | 57.8           | 35.9              | 36.4                | 58.3               | 68.2                      | -9.9        |

| Polarization | Frequency (MHz) | Reading (dB $\mu$ V) | Pre-Amp Gain (dB) | Antenna Factor (dB) | Net at 3m (dB $\mu$ V/m) | Peak Limit at 3m (dB $\mu$ V/m) | Margin (dB) |
|--------------|-----------------|----------------------|-------------------|---------------------|--------------------------|---------------------------------|-------------|
| Horizontal   | *15720          | 40.0                 | 34.7              | 41.0                | 46.3                     | 54.0                            | -7.7        |
| Horizontal   | *5351.562       | 46.0                 | 35.9              | 36.4                | 46.5                     | 54.0                            | -7.5        |

Test Condition : 802.11n-HT40, SISO, Ant1, Channel 38/13.5Mbps

| Polarization | Frequency (MHz) | Reading (dB $\mu$ V) | Pre-Amp Gain (dB) | Antenna Factor (dB) | Net at 3m (dB $\mu$ V/m) | Peak Limit at 3m (dB $\mu$ V/m) | Margin (dB) |
|--------------|-----------------|----------------------|-------------------|---------------------|--------------------------|---------------------------------|-------------|
| Horizontal   | 10380.000       | 58.1                 | 36.3              | 38.9                | 60.7                     | 68.2                            | -7.5        |
| Horizontal   | 15570.000       | 55.2                 | 34.7              | 41.0                | 61.5                     | 68.2                            | -6.7        |
| Horizontal   | 5148.850        | 57.1                 | 36.1              | 35.5                | 56.5                     | 68.2                            | -11.7       |

| Polarization | Frequency (MHz) | Reading (dB $\mu$ V) | Pre-Amp Gain (dB) | Antenna Factor (dB) | Net at 3m (dB $\mu$ V/m) | Peak Limit at 3m (dB $\mu$ V/m) | Margin (dB) |
|--------------|-----------------|----------------------|-------------------|---------------------|--------------------------|---------------------------------|-------------|
| Horizontal   | *15570          | 44.3                 | 34.7              | 41.0                | 50.6                     | 54.0                            | -3.4        |
| Horizontal   | *5148.850       | 47.4                 | 36.1              | 35.5                | 46.8                     | 54.0                            | -7.2        |

Test Condition : 802.11n-HT40, SISO, Ant1, Channel 46/13.5Mbps

| Polarization | Frequency (MHz) | Reading (dB $\mu$ V) | Pre-Amp Gain (dB) | Antenna Factor (dB) | Net at 3m (dB $\mu$ V/m) | Peak Limit at 3m (dB $\mu$ V/m) | Margin (dB) |
|--------------|-----------------|----------------------|-------------------|---------------------|--------------------------|---------------------------------|-------------|
| Horizontal   | 10460.000       | 58.7                 | 36.3              | 38.9                | 61.3                     | 68.2                            | -6.9        |
| Horizontal   | 15690.000       | 55.2                 | 34.7              | 41.0                | 61.5                     | 68.2                            | -6.7        |
| Horizontal   | 5352.600        | 58.5                 | 35.9              | 36.4                | 59.0                     | 68.2                            | -9.2        |

| Polarization | Frequency (MHz) | Reading (dB $\mu$ V) | Pre-Amp Gain (dB) | Antenna Factor (dB) | Net at 3m (dB $\mu$ V/m) | Peak Limit at 3m (dB $\mu$ V/m) | Margin (dB) |
|--------------|-----------------|----------------------|-------------------|---------------------|--------------------------|---------------------------------|-------------|
| Horizontal   | *15690          | 45.2                 | 34.7              | 41.0                | 51.5                     | 54.0                            | -2.5        |
| Horizontal   | *5352.6         | 47.3                 | 35.9              | 36.4                | 47.8                     | 54.0                            | -6.2        |

Test Condition : 802.11n-HT40, MIMO, Ant1+2+3+4, Channel 38/54Mbps

| Polarization | Frequency (MHz) | Reading (dBμV) | Pre-Amp Gain (dB) | Antenna Factor (dB) | Net at 3m (dBμV/m) | Peak Limit at 3m (dBμV/m) | Margin (dB) |
|--------------|-----------------|----------------|-------------------|---------------------|--------------------|---------------------------|-------------|
| Horizontal   | 10380.000       | 58.4           | 36.3              | 38.9                | 61.0               | 68.2                      | -7.2        |
| Horizontal   | 15570.000       | 53.1           | 34.7              | 41.0                | 59.4               | 68.2                      | -8.8        |
| Horizontal   | 5148.674        | 59.1           | 36.1              | 35.5                | 58.5               | 68.2                      | -9.7        |

| Polarization | Frequency (MHz) | Reading (dBμV) | Pre-Amp Gain (dB) | Antenna Factor (dB) | Net at 3m (dBμV/m) | Peak Limit at 3m (dBμV/m) | Margin (dB) |
|--------------|-----------------|----------------|-------------------|---------------------|--------------------|---------------------------|-------------|
| Horizontal   | *15570          | 42.5           | 34.7              | 41.0                | 48.8               | 54.0                      | -5.2        |
| Horizontal   | *5148.674       | 47.5           | 36.1              | 35.5                | 46.9               | 54.0                      | -7.1        |

Test Condition : 802.11n-HT40, MIMO, Ant1+2+3+4, Channel 46/54Mbps

| Polarization | Frequency (MHz) | Reading (dBμV) | Pre-Amp Gain (dB) | Antenna Factor (dB) | Net at 3m (dBμV/m) | Peak Limit at 3m (dBμV/m) | Margin (dB) |
|--------------|-----------------|----------------|-------------------|---------------------|--------------------|---------------------------|-------------|
| Horizontal   | 10460.000       | 58.6           | 36.3              | 38.9                | 61.2               | 68.2                      | -7.0        |
| Horizontal   | 15690.000       | 53.5           | 34.7              | 41.0                | 59.8               | 68.2                      | -8.4        |
| Horizontal   | 5351.780        | 58.7           | 35.9              | 36.4                | 59.2               | 68.2                      | -9.0        |

| Polarization | Frequency (MHz) | Reading (dBμV) | Pre-Amp Gain (dB) | Antenna Factor (dB) | Net at 3m (dBμV/m) | Peak Limit at 3m (dBμV/m) | Margin (dB) |
|--------------|-----------------|----------------|-------------------|---------------------|--------------------|---------------------------|-------------|
| Horizontal   | *15690          | 43.6           | 34.7              | 41.0                | 49.9               | 54.0                      | -4.1        |
| Horizontal   | *5351.78        | 47.3           | 35.9              | 36.4                | 47.8               | 54.0                      | -6.2        |

Test Condition : 802.11ac-HT20, SISO, Ant1, Channel 36/6.5Mbps

| Polarization | Frequency (MHz) | Reading (dBμV) | Pre-Amp Gain (dB) | Antenna Factor (dB) | Net at 3m (dBμV/m) | Peak Limit at 3m (dBμV/m) | Margin (dB) |
|--------------|-----------------|----------------|-------------------|---------------------|--------------------|---------------------------|-------------|
| Horizontal   | 10360.000       | 60.5           | 36.3              | 38.9                | 63.1               | 68.2                      | -5.1        |
| Horizontal   | 15540.000       | 53.9           | 34.7              | 41.0                | 60.2               | 68.2                      | -8.0        |
| Horizontal   | 5148.550        | 59.5           | 36.1              | 35.5                | 58.9               | 68.2                      | -9.3        |

| Polarization | Frequency (MHz) | Reading (dBμV) | Pre-Amp Gain (dB) | Antenna Factor (dB) | Net at 3m (dBμV/m) | Peak Limit at 3m (dBμV/m) | Margin (dB) |
|--------------|-----------------|----------------|-------------------|---------------------|--------------------|---------------------------|-------------|
| Horizontal   | *15540          | 43.5           | 34.7              | 41.0                | 49.8               | 54.0                      | -4.2        |
| Horizontal   | *5148.550       | 49.7           | 36.1              | 35.5                | 49.1               | 54.0                      | -4.9        |

Test Condition : 802.11ac-HT20, SISO, Ant1, Channel 40/6.5Mbps

| Polarization | Frequency (MHz) | Reading (dBμV) | Pre-Amp Gain (dB) | Antenna Factor (dB) | Net at 3m (dBμV/m) | Peak Limit at 3m (dBμV/m) | Margin (dB) |
|--------------|-----------------|----------------|-------------------|---------------------|--------------------|---------------------------|-------------|
| Horizontal   | 10400.000       | 61.5           | 36.3              | 38.9                | 64.1               | 68.2                      | -4.1        |
| Horizontal   | 15600.000       | 53.0           | 34.7              | 41.0                | 59.3               | 68.2                      | -8.9        |

| Polarization | Frequency (MHz) | Reading (dBμV) | Pre-Amp Gain (dB) | Antenna Factor (dB) | Net at 3m (dBμV/m) | Peak Limit at 3m (dBμV/m) | Margin (dB) |
|--------------|-----------------|----------------|-------------------|---------------------|--------------------|---------------------------|-------------|
| Horizontal   | *15600          | 42.9           | 34.7              | 41.0                | 49.2               | 54.0                      | -4.8        |

Test Condition : 802.11ac-HT20, SISO, Ant1, Channel 48/6.5Mbps

| Polarization | Frequency (MHz) | Reading (dBμV) | Pre-Amp Gain (dB) | Antenna Factor (dB) | Net at 3m (dBμV/m) | Peak Limit at 3m (dBμV/m) | Margin (dB) |
|--------------|-----------------|----------------|-------------------|---------------------|--------------------|---------------------------|-------------|
| Horizontal   | 10480.000       | 60.9           | 36.3              | 38.9                | 63.5               | 68.2                      | -4.7        |
| Horizontal   | 15720.000       | 53.3           | 34.7              | 41.0                | 59.6               | 68.2                      | -8.6        |
| Horizontal   | 5351.598        | 58.3           | 35.9              | 36.4                | 58.8               | 68.2                      | -9.4        |

| Polarization | Frequency (MHz) | Reading (dBμV) | Pre-Amp Gain (dB) | Antenna Factor (dB) | Net at 3m (dBμV/m) | Average Limit at 3m (dBμV/m) | Margin (dB) |
|--------------|-----------------|----------------|-------------------|---------------------|--------------------|------------------------------|-------------|
| Horizontal   | *15720          | 43.5           | 34.7              | 41.0                | 49.8               | 54.0                         | -4.2        |
| Horizontal   | *5351.98        | 46.4           | 35.9              | 36.4                | 46.9               | 54.0                         | -7.1        |

Test Condition : 802.11ac-HT20, MIMO, Ant1+2+3+4, Channel 36/26Mbps

| Polarization | Frequency (MHz) | Reading (dBμV) | Pre-Amp Gain (dB) | Antenna Factor (dB) | Net at 3m (dBμV/m) | Peak Limit at 3m (dBμV/m) | Margin (dB) |
|--------------|-----------------|----------------|-------------------|---------------------|--------------------|---------------------------|-------------|
| Horizontal   | 10360.000       | 57.9           | 36.3              | 38.9                | 60.5               | 68.2                      | -7.7        |
| Horizontal   | 15540.000       | 54.3           | 34.7              | 41.0                | 60.6               | 68.2                      | -7.6        |
| Horizontal   | 5149.700        | 59.4           | 36.1              | 35.5                | 58.8               | 68.2                      | -9.4        |

| Polarization | Frequency (MHz) | Reading (dBμV) | Pre-Amp Gain (dB) | Antenna Factor (dB) | Net at 3m (dBμV/m) | Average Limit at 3m (dBμV/m) | Margin (dB) |
|--------------|-----------------|----------------|-------------------|---------------------|--------------------|------------------------------|-------------|
| Horizontal   | *15540          | 41.3           | 34.7              | 41.0                | 47.6               | 54.0                         | -6.4        |
| Horizontal   | *5149.7         | 50.5           | 36.1              | 35.5                | 49.9               | 54.0                         | -4.1        |

Test Condition : 802.11ac-HT20, MIMO, Ant1+2+3+4, Channel 40/26Mbps

| Polarization | Frequency (MHz) | Reading (dBμV) | Pre-Amp Gain (dB) | Antenna Factor (dB) | Net at 3m (dBμV/m) | Peak Limit at 3m (dBμV/m) | Margin (dB) |
|--------------|-----------------|----------------|-------------------|---------------------|--------------------|---------------------------|-------------|
| Horizontal   | 10400.000       | 57.8           | 36.3              | 38.9                | 60.4               | 68.2                      | -7.8        |
| Horizontal   | 15600.000       | 53.8           | 34.7              | 41.0                | 60.1               | 68.2                      | -8.1        |

| Polarization | Frequency (MHz) | Reading (dBμV) | Pre-Amp Gain (dB) | Antenna Factor (dB) | Net at 3m (dBμV/m) | Average Limit at 3m (dBμV/m) | Margin (dB) |
|--------------|-----------------|----------------|-------------------|---------------------|--------------------|------------------------------|-------------|
| Horizontal   | *15600          | 43.7           | 34.7              | 41.0                | 50.0               | 54.0                         | -4.0        |

Test Condition : 802.11ac-HT20, MIMO, Ant1+2+3+4, Channel 48/26Mbps

| Polarization | Frequency (MHz) | Reading (dBμV) | Pre-Amp Gain (dB) | Antenna Factor (dB) | Net at 3m (dBμV/m) | Peak Limit at 3m (dBμV/m) | Margin (dB) |
|--------------|-----------------|----------------|-------------------|---------------------|--------------------|---------------------------|-------------|
| Horizontal   | 10480.000       | 58.6           | 36.3              | 38.9                | 61.2               | 68.2                      | -7.0        |
| Horizontal   | 15720.000       | 54.1           | 34.7              | 41.0                | 60.4               | 68.2                      | -7.8        |
| Horizontal   | 5351.600        | 59.3           | 35.9              | 36.4                | 59.8               | 68.2                      | -8.4        |

| Polarization | Frequency (MHz) | Reading (dBμV) | Pre-Amp Gain (dB) | Antenna Factor (dB) | Net at 3m (dBμV/m) | Average Limit at 3m (dBμV/m) | Margin (dB) |
|--------------|-----------------|----------------|-------------------|---------------------|--------------------|------------------------------|-------------|
| Horizontal   | *15720          | 43.6           | 34.7              | 41.0                | 49.9               | 54.0                         | -4.1        |
| Horizontal   | *5351.6         | 47.0           | 35.9              | 36.4                | 47.5               | 54.0                         | -6.5        |

Test Condition : 802.11ac-HT40, SISO, Ant1, Channel 38/13.5Mbps

| Polarization | Frequency (MHz) | Reading (dBμV) | Pre-Amp Gain (dB) | Antenna Factor (dB) | Net at 3m (dBμV/m) | Peak Limit at 3m (dBμV/m) | Margin (dB) |
|--------------|-----------------|----------------|-------------------|---------------------|--------------------|---------------------------|-------------|
| Horizontal   | 10380.000       | 56.7           | 36.3              | 38.9                | 59.3               | 68.2                      | -8.9        |
| Horizontal   | 15570.000       | 54.1           | 34.7              | 41.0                | 60.4               | 68.2                      | -7.8        |
| Horizontal   | 5148.980        | 58.8           | 36.1              | 35.5                | 58.2               | 68.2                      | -10.0       |

| Polarization | Frequency (MHz) | Reading (dBμV) | Pre-Amp Gain (dB) | Antenna Factor (dB) | Net at 3m (dBμV/m) | Average Limit at 3m (dBμV/m) | Margin (dB) |
|--------------|-----------------|----------------|-------------------|---------------------|--------------------|------------------------------|-------------|
| Horizontal   | *15570          | 43.2           | 34.7              | 41.0                | 49.5               | 54.0                         | -4.5        |
| Horizontal   | *5148.98        | 48.4           | 36.1              | 35.5                | 47.8               | 54.0                         | -6.2        |

Test Condition : 802.11ac-HT40, SISO, Ant1, Channel 46/13.5Mbps

| Polarization | Frequency (MHz) | Reading (dBμV) | Pre-Amp Gain (dB) | Antenna Factor (dB) | Net at 3m (dBμV/m) | Peak Limit at 3m (dBμV/m) | Margin (dB) |
|--------------|-----------------|----------------|-------------------|---------------------|--------------------|---------------------------|-------------|
| Horizontal   | 10460.000       | 56.0           | 36.3              | 38.9                | 58.6               | 68.2                      | -9.6        |
| Horizontal   | 15690.000       | 52.4           | 34.7              | 41.0                | 58.7               | 68.2                      | -9.5        |
| Horizontal   | 5352.670        | 58.4           | 35.9              | 36.4                | 58.9               | 68.2                      | -9.3        |

| Polarization | Frequency (MHz) | Reading (dBμV) | Pre-Amp Gain (dB) | Antenna Factor (dB) | Net at 3m (dBμV/m) | Average Limit at 3m (dBμV/m) | Margin (dB) |
|--------------|-----------------|----------------|-------------------|---------------------|--------------------|------------------------------|-------------|
| Horizontal   | *15690          | 43.2           | 34.7              | 41.0                | 49.5               | 54.0                         | -4.5        |
| Horizontal   | *5352.67        | 48.1           | 35.9              | 36.4                | 48.6               | 54.0                         | -5.4        |

Test Condition : 802.11ac-HT40, MIMO, Ant1+2+3+4, Channel 38/54Mbps

| Polarization | Frequency (MHz) | Reading (dBμV) | Pre-Amp Gain (dB) | Antenna Factor (dB) | Net at 3m (dBμV/m) | Peak Limit at 3m (dBμV/m) | Margin (dB) |
|--------------|-----------------|----------------|-------------------|---------------------|--------------------|---------------------------|-------------|
| Horizontal   | 10380.000       | 56.6           | 36.3              | 38.9                | 59.2               | 68.2                      | -9.0        |
| Horizontal   | 15570.000       | 51.9           | 34.7              | 41.0                | 58.2               | 68.2                      | -10.0       |
| Horizontal   | 5148.890        | 58.4           | 36.1              | 35.5                | 57.8               | 68.2                      | -10.4       |

| Polarization | Frequency (MHz) | Reading (dBμV) | Pre-Amp Gain (dB) | Antenna Factor (dB) | Net at 3m (dBμV/m) | Average Limit at 3m (dBμV/m) | Margin (dB) |
|--------------|-----------------|----------------|-------------------|---------------------|--------------------|------------------------------|-------------|
| Horizontal   | *15570          | 40.5           | 34.7              | 41.0                | 46.8               | 54.0                         | -7.2        |
| Horizontal   | *5148.890       | 50.3           | 36.1              | 35.5                | 49.7               | 54.0                         | -4.3        |

Test Condition : 802.11ac-HT40, MIMO, Ant1+2+3+4, Channel 46/54Mbps

| Polarization | Frequency (MHz) | Reading (dBμV) | Pre-Amp Gain (dB) | Antenna Factor (dB) | Net at 3m (dBμV/m) | Peak Limit at 3m (dBμV/m) | Margin (dB) |
|--------------|-----------------|----------------|-------------------|---------------------|--------------------|---------------------------|-------------|
| Horizontal   | 10460.000       | 58.9           | 36.3              | 38.9                | 61.5               | 68.2                      | -6.7        |
| Horizontal   | 15690.000       | 55.3           | 34.7              | 41.0                | 61.6               | 68.2                      | -6.6        |
| Horizontal   | 5352.700        | 58.2           | 35.9              | 36.4                | 58.7               | 68.2                      | -9.5        |

| Polarization | Frequency (MHz) | Reading (dBμV) | Pre-Amp Gain (dB) | Antenna Factor (dB) | Net at 3m (dBμV/m) | Average Limit at 3m (dBμV/m) | Margin (dB) |
|--------------|-----------------|----------------|-------------------|---------------------|--------------------|------------------------------|-------------|
| Horizontal   | *15690          | 42.8           | 34.7              | 41.0                | 49.1               | 54.0                         | -4.9        |
| Horizontal   | *5352.7         | 47.1           | 35.9              | 36.4                | 47.6               | 54.0                         | -6.4        |

Test Condition : 802.11ac, SISO, Ant1, Channel 42/29.3Mbps

| Polarization | Frequency (MHz) | Reading (dBμV) | Pre-Amp Gain (dB) | Antenna Factor (dB) | Net at 3m (dBμV/m) | Peak Limit at 3m (dBμV/m) | Margin (dB) |
|--------------|-----------------|----------------|-------------------|---------------------|--------------------|---------------------------|-------------|
| Horizontal   | 10420.000       | 55.6           | 36.3              | 38.9                | 58.2               | 68.2                      | -10.0       |
| Horizontal   | 15630.000       | 52.7           | 34.7              | 41.0                | 59.0               | 68.2                      | -9.2        |
| Horizontal   | 5148.450        | 58.3           | 35.9              | 36.4                | 58.8               | 68.2                      | -9.4        |
| Horizontal   | 5351.465        | 58.2           | 35.9              | 36.4                | 58.7               | 68.2                      | -9.5        |

| Polarization | Frequency (MHz) | Reading (dBμV) | Pre-Amp Gain (dB) | Antenna Factor (dB) | Net at 3m (dBμV/m) | Average Limit at 3m (dBμV/m) | Margin (dB) |
|--------------|-----------------|----------------|-------------------|---------------------|--------------------|------------------------------|-------------|
| Horizontal   | *15630          | 43.1           | 34.7              | 41.0                | 49.4               | 54.0                         | -4.6        |
| Horizontal   | *5148.450       | 47.2           | 35.9              | 36.4                | 47.7               | 54.0                         | -6.3        |
| Horizontal   | *5351.465       | 46.4           | 35.9              | 36.4                | 46.9               | 54.0                         | -7.1        |

Test Condition : 802.11ac, MIMO, Ant1+2+3+4, Channel 42/117.2Mbps

| Polarization | Frequency (MHz) | Reading (dBμV) | Pre-Amp Gain (dB) | Antenna Factor (dB) | Net at 3m (dBμV/m) | Peak Limit at 3m (dBμV/m) | Margin (dB) |
|--------------|-----------------|----------------|-------------------|---------------------|--------------------|---------------------------|-------------|
| Horizontal   | 10420.000       | 56.3           | 36.3              | 38.9                | 58.9               | 68.2                      | -9.3        |
| Horizontal   | 15630.000       | 53.6           | 34.7              | 41.0                | 59.9               | 68.2                      | -8.3        |
| Horizontal   | 5148.561        | 56.4           | 35.9              | 36.4                | 56.9               | 68.2                      | -11.3       |
| Horizontal   | 5352.586        | 57.0           | 35.9              | 36.4                | 57.5               | 68.2                      | -10.7       |

| Polarization | Frequency (MHz) | Reading (dBμV) | Pre-Amp Gain (dB) | Antenna Factor (dB) | Net at 3m (dBμV/m) | Average Limit at 3m (dBμV/m) | Margin (dB) |
|--------------|-----------------|----------------|-------------------|---------------------|--------------------|------------------------------|-------------|
| Horizontal   | *15630          | 41.5           | 34.7              | 41.0                | 47.8               | 54.0                         | -6.2        |
| Horizontal   | *5148.561       | 47.9           | 35.9              | 36.4                | 48.4               | 54.0                         | -5.6        |
| Horizontal   | *5352.586       | 47.1           | 35.9              | 36.4                | 47.6               | 54.0                         | -6.4        |

Test Condition : 802.11a, SISO, Ant1, Channel 149/6Mbps

| Polarization | Frequency (MHz) | Reading (dBμV) | Pre-Amp Gain (dB) | Antenna Factor (dB) | Net at 3m (dBμV/m) | Peak Limit at 3m (dBμV/m) | Margin (dB) |
|--------------|-----------------|----------------|-------------------|---------------------|--------------------|---------------------------|-------------|
| Horizontal   | 11490.000       | 54.3           | 35.3              | 41.2                | 60.2               | 68.2                      | -8.0        |
| Horizontal   | 17235.000       | 55.3           | 33.9              | 39.2                | 60.6               | 68.2                      | -7.6        |
| Horizontal   | 5716.399        | 68.2           | 36.7              | 27.2                | 58.7               | 78.2                      | -19.5       |

| Polarization | Frequency (MHz) | Reading (dBμV) | Pre-Amp Gain (dB) | Antenna Factor (dB) | Net at 3m (dBμV/m) | Average Limit at 3m (dBμV/m) | Margin (dB) |
|--------------|-----------------|----------------|-------------------|---------------------|--------------------|------------------------------|-------------|
| Horizontal   | *11490          | 41.7           | 35.3              | 41.2                | 47.6               | 54.0                         | -6.4        |

Test Condition : 802.11a, SISO, Ant1, Channel 157/6Mbps

| Polarization | Frequency (MHz) | Reading (dBμV) | Pre-Amp Gain (dB) | Antenna Factor (dB) | Net at 3m (dBμV/m) | Peak Limit at 3m (dBμV/m) | Margin (dB) |
|--------------|-----------------|----------------|-------------------|---------------------|--------------------|---------------------------|-------------|
| Horizontal   | 11570.000       | 54.4           | 35.3              | 41.2                | 60.3               | 68.2                      | -7.9        |
| Horizontal   | 17355.000       | 54.2           | 33.9              | 39.2                | 59.5               | 68.2                      | -8.7        |

| Polarization | Frequency (MHz) | Reading (dBμV) | Pre-Amp Gain (dB) | Antenna Factor (dB) | Net at 3m (dBμV/m) | Average Limit at 3m (dBμV/m) | Margin (dB) |
|--------------|-----------------|----------------|-------------------|---------------------|--------------------|------------------------------|-------------|
| Horizontal   | *11570          | 43.9           | 35.3              | 41.2                | 49.8               | 54.0                         | -4.2        |

Test Condition : 802.11a, SISO, Ant1, Channel 165/6Mbps

| Polarization | Frequency (MHz) | Reading (dBμV) | Pre-Amp Gain (dB) | Antenna Factor (dB) | Net at 3m (dBμV/m) | Peak Limit at 3m (dBμV/m) | Margin (dB) |
|--------------|-----------------|----------------|-------------------|---------------------|--------------------|---------------------------|-------------|
| Horizontal   | 11650.000       | 53.0           | 35.3              | 41.2                | 58.9               | 68.2                      | -9.3        |
| Horizontal   | 17475.000       | 54.9           | 33.9              | 39.2                | 60.2               | 68.2                      | -8.0        |
| Horizontal   | 5856.399        | 71.5           | 36.7              | 27.7                | 62.5               | 78.2                      | -15.7       |

| Polarization | Frequency (MHz) | Reading (dBμV) | Pre-Amp Gain (dB) | Antenna Factor (dB) | Net at 3m (dBμV/m) | Average Limit at 3m (dBμV/m) | Margin (dB) |
|--------------|-----------------|----------------|-------------------|---------------------|--------------------|------------------------------|-------------|
| Horizontal   | *11650          | 43.3           | 35.3              | 41.2                | 49.2               | 54.0                         | -4.8        |

Test Condition : 802.11n-HT20, SISO, Ant1, Channel 149/6.5Mbps

| Polarization | Frequency (MHz) | Reading (dBμV) | Pre-Amp Gain (dB) | Antenna Factor (dB) | Net at 3m (dBμV/m) | Peak Limit at 3m (dBμV/m) | Margin (dB) |
|--------------|-----------------|----------------|-------------------|---------------------|--------------------|---------------------------|-------------|
| Horizontal   | 11490.000       | 55.6           | 35.3              | 41.2                | 61.5               | 68.2                      | -6.7        |
| Horizontal   | 17235.000       | 57.0           | 33.9              | 39.2                | 62.3               | 68.2                      | -5.9        |
| Horizontal   | 5718.024        | 70.9           | 36.7              | 27.2                | 61.4               | 78.2                      | -16.8       |



| Polarization | Frequency (MHz) | Reading (dB $\mu$ V) | Pre-Amp Gain (dB) | Antenna Factor (dB) | Net at 3m (dB $\mu$ V/m) | Average Limit at 3m (dB $\mu$ V/m) | Margin (dB) |
|--------------|-----------------|----------------------|-------------------|---------------------|--------------------------|------------------------------------|-------------|
| Horizontal   | *11490          | 41.6                 | 35.3              | 41.2                | 47.5                     | 54.0                               | -6.5        |

Test Condition : 802.11n-HT20, SISO, Ant1, Channel 157/6.5Mbps

| Polarization | Frequency (MHz) | Reading (dB $\mu$ V) | Pre-Amp Gain (dB) | Antenna Factor (dB) | Net at 3m (dB $\mu$ V/m) | Peak Limit at 3m (dB $\mu$ V/m) | Margin (dB) |
|--------------|-----------------|----------------------|-------------------|---------------------|--------------------------|---------------------------------|-------------|
| Horizontal   | 11570.000       | 54.4                 | 35.3              | 41.2                | 60.3                     | 68.2                            | -7.9        |
| Horizontal   | 17355.000       | 55.2                 | 33.9              | 39.2                | 60.5                     | 68.2                            | -7.7        |

| Polarization | Frequency (MHz) | Reading (dB $\mu$ V) | Pre-Amp Gain (dB) | Antenna Factor (dB) | Net at 3m (dB $\mu$ V/m) | Average Limit at 3m (dB $\mu$ V/m) | Margin (dB) |
|--------------|-----------------|----------------------|-------------------|---------------------|--------------------------|------------------------------------|-------------|
| Horizontal   | *11570          | 41.9                 | 35.3              | 41.2                | 47.8                     | 54.0                               | -6.2        |

Test Condition : 802.11n-HT20, SISO, Ant1, Channel 165/6.5Mbps

| Polarization | Frequency (MHz) | Reading (dB $\mu$ V) | Pre-Amp Gain (dB) | Antenna Factor (dB) | Net at 3m (dB $\mu$ V/m) | Peak Limit at 3m (dB $\mu$ V/m) | Margin (dB) |
|--------------|-----------------|----------------------|-------------------|---------------------|--------------------------|---------------------------------|-------------|
| Horizontal   | 11650.000       | 54.4                 | 35.3              | 41.2                | 60.3                     | 68.2                            | -7.9        |
| Horizontal   | 17475.000       | 55.1                 | 33.9              | 39.2                | 60.4                     | 68.2                            | -7.8        |
| Horizontal   | 5855.892        | 68.4                 | 36.7              | 27.7                | 59.4                     | 78.2                            | -18.8       |

| Polarization | Frequency (MHz) | Reading (dB $\mu$ V) | Pre-Amp Gain (dB) | Antenna Factor (dB) | Net at 3m (dB $\mu$ V/m) | Average Limit at 3m (dB $\mu$ V/m) | Margin (dB) |
|--------------|-----------------|----------------------|-------------------|---------------------|--------------------------|------------------------------------|-------------|
| Horizontal   | *11650          | 42.7                 | 35.3              | 41.2                | 48.6                     | 54.0                               | -5.4        |

Test Condition : 802.11n-HT20, MIMO, Ant1+2+3+4, Channel 149/26Mbps

| Polarization | Frequency (MHz) | Reading (dB $\mu$ V) | Pre-Amp Gain (dB) | Antenna Factor (dB) | Net at 3m (dB $\mu$ V/m) | Peak Limit at 3m (dB $\mu$ V/m) | Margin (dB) |
|--------------|-----------------|----------------------|-------------------|---------------------|--------------------------|---------------------------------|-------------|
| Horizontal   | 11490.000       | 54.6                 | 35.3              | 41.2                | 60.5                     | 68.2                            | -7.7        |
| Horizontal   | 17235.000       | 56.7                 | 33.9              | 39.2                | 62.0                     | 68.2                            | -6.2        |
| Horizontal   | 5717.168        | 70.3                 | 36.7              | 27.2                | 60.8                     | 78.2                            | -17.4       |

| Polarization | Frequency (MHz) | Reading (dB $\mu$ V) | Pre-Amp Gain (dB) | Antenna Factor (dB) | Net at 3m (dB $\mu$ V/m) | Average Limit at 3m (dB $\mu$ V/m) | Margin (dB) |
|--------------|-----------------|----------------------|-------------------|---------------------|--------------------------|------------------------------------|-------------|
| Horizontal   | *11490          | 42.8                 | 35.3              | 41.2                | 48.7                     | 54.0                               | -5.3        |

Test Condition : 802.11n-HT20, MIMO, Ant1+2+3+4, Channel 157/26Mbps

| Polarization | Frequency (MHz) | Reading (dB $\mu$ V) | Pre-Amp Gain (dB) | Antenna Factor (dB) | Net at 3m (dB $\mu$ V/m) | Peak Limit at 3m (dB $\mu$ V/m) | Margin (dB) |
|--------------|-----------------|----------------------|-------------------|---------------------|--------------------------|---------------------------------|-------------|
| Horizontal   | 11570.000       | 55.0                 | 35.3              | 41.2                | 60.9                     | 68.2                            | -7.3        |
| Horizontal   | 17355.000       | 55.1                 | 33.9              | 39.2                | 60.4                     | 68.2                            | -7.8        |

| Polarization | Frequency (MHz) | Reading (dB $\mu$ V) | Pre-Amp Gain (dB) | Antenna Factor (dB) | Net at 3m (dB $\mu$ V/m) | Average Limit at 3m (dB $\mu$ V/m) | Margin (dB) |
|--------------|-----------------|----------------------|-------------------|---------------------|--------------------------|------------------------------------|-------------|
| Horizontal   | *11570          | 41.9                 | 35.3              | 41.2                | 47.8                     | 54.0                               | -6.2        |

Test Condition : 802.11n-HT20, MIMO, Ant1+2+3+4, Channel 165/26Mbps

| Polarization | Frequency (MHz) | Reading (dB $\mu$ V) | Pre-Amp Gain (dB) | Antenna Factor (dB) | Net at 3m (dB $\mu$ V/m) | Peak Limit at 3m (dB $\mu$ V/m) | Margin (dB) |
|--------------|-----------------|----------------------|-------------------|---------------------|--------------------------|---------------------------------|-------------|
| Horizontal   | 11650.000       | 56.1                 | 35.3              | 41.2                | 62.0                     | 68.2                            | -6.2        |
| Horizontal   | 17475.000       | 56.0                 | 33.9              | 39.2                | 61.3                     | 68.2                            | -6.9        |
| Horizontal   | 5853.530        | 67.5                 | 36.7              | 27.7                | 58.5                     | 78.2                            | -19.7       |

| Polarization | Frequency (MHz) | Reading (dB $\mu$ V) | Pre-Amp Gain (dB) | Antenna Factor (dB) | Net at 3m (dB $\mu$ V/m) | Average Limit at 3m (dB $\mu$ V/m) | Margin (dB) |
|--------------|-----------------|----------------------|-------------------|---------------------|--------------------------|------------------------------------|-------------|
| Horizontal   | *11650          | 43.6                 | 35.3              | 41.2                | 49.5                     | 54.0                               | -4.5        |

Test Condition : 802.11n-HT40, SISO, Ant1, Channel 151/13.5Mbps

| Polarization | Frequency (MHz) | Reading (dB $\mu$ V) | Pre-Amp Gain (dB) | Antenna Factor (dB) | Net at 3m (dB $\mu$ V/m) | Peak Limit at 3m (dB $\mu$ V/m) | Margin (dB) |
|--------------|-----------------|----------------------|-------------------|---------------------|--------------------------|---------------------------------|-------------|
| Horizontal   | 11510.000       | 54.3                 | 35.3              | 41.2                | 60.2                     | 68.2                            | -8.0        |
| Horizontal   | 17265.000       | 55.3                 | 33.9              | 39.2                | 60.6                     | 68.2                            | -7.6        |
| Horizontal   | 5719.004        | 69.8                 | 36.8              | 26.5                | 59.5                     | 78.2                            | -18.7       |

| Polarization | Frequency (MHz) | Reading (dBμV) | Pre-Amp Gain (dB) | Antenna Factor (dB) | Net at 3m (dBμV/m) | Average Limit at 3m (dBμV/m) | Margin (dB) |
|--------------|-----------------|----------------|-------------------|---------------------|--------------------|------------------------------|-------------|
| Horizontal   | *11510          | 43.9           | 35.3              | 41.2                | 49.8               | 54.0                         | -4.2        |

Test Condition : 802.11n-HT40, SISO, Ant1, Channel 159/13.5Mbps

| Polarization | Frequency (MHz) | Reading (dBμV) | Pre-Amp Gain (dB) | Antenna Factor (dB) | Net at 3m (dBμV/m) | Peak Limit at 3m (dBμV/m) | Margin (dB) |
|--------------|-----------------|----------------|-------------------|---------------------|--------------------|---------------------------|-------------|
| Horizontal   | 11590.000       | 53.9           | 35.3              | 41.2                | 59.8               | 68.2                      | -8.4        |
| Horizontal   | 17385.000       | 55.3           | 33.9              | 39.2                | 60.6               | 68.2                      | -7.6        |
| Horizontal   | 5855.890        | 72.5           | 36.7              | 27.7                | 63.5               | 78.2                      | -14.7       |

| Polarization | Frequency (MHz) | Reading (dBμV) | Pre-Amp Gain (dB) | Antenna Factor (dB) | Net at 3m (dBμV/m) | Average Limit at 3m (dBμV/m) | Margin (dB) |
|--------------|-----------------|----------------|-------------------|---------------------|--------------------|------------------------------|-------------|
| Horizontal   | *11590          | 43.4           | 35.3              | 41.2                | 49.3               | 54.0                         | -4.7        |

Test Condition : 802.11n-HT40, MIMO, Ant1+2+3+4, Channel 151/54Mbps

| Polarization | Frequency (MHz) | Reading (dBμV) | Pre-Amp Gain (dB) | Antenna Factor (dB) | Net at 3m (dBμV/m) | Peak Limit at 3m (dBμV/m) | Margin (dB) |
|--------------|-----------------|----------------|-------------------|---------------------|--------------------|---------------------------|-------------|
| Horizontal   | 11510.000       | 54.6           | 35.3              | 41.2                | 60.5               | 68.2                      | -7.7        |
| Horizontal   | 17265.000       | 56.3           | 33.9              | 39.2                | 61.6               | 68.2                      | -6.6        |
| Horizontal   | 5722.425        | 73.8           | 36.8              | 26.5                | 63.5               | 78.2                      | -14.7       |

| Polarization | Frequency (MHz) | Reading (dBμV) | Pre-Amp Gain (dB) | Antenna Factor (dB) | Net at 3m (dBμV/m) | Average Limit at 3m (dBμV/m) | Margin (dB) |
|--------------|-----------------|----------------|-------------------|---------------------|--------------------|------------------------------|-------------|
| Horizontal   | *11510          | 43.7           | 35.3              | 41.2                | 49.6               | 54.0                         | -4.4        |

Test Condition : 802.11n-HT40, MIMO, Ant1+2+3+4, Channel 159/54Mbps

| Polarization | Frequency (MHz) | Reading (dBμV) | Pre-Amp Gain (dB) | Antenna Factor (dB) | Net at 3m (dBμV/m) | Peak Limit at 3m (dBμV/m) | Margin (dB) |
|--------------|-----------------|----------------|-------------------|---------------------|--------------------|---------------------------|-------------|
| Horizontal   | 11590.000       | 54.0           | 35.3              | 41.2                | 59.9               | 68.2                      | -8.3        |
| Horizontal   | 17385.000       | 55.9           | 33.9              | 39.2                | 61.2               | 68.2                      | -7.0        |
| Horizontal   | 5852.221        | 72.0           | 36.7              | 27.7                | 63.0               | 78.2                      | -15.2       |

| Polarization | Frequency (MHz) | Reading (dBμV) | Pre-Amp Gain (dB) | Antenna Factor (dB) | Net at 3m (dBμV/m) | Average Limit at 3m (dBμV/m) | Margin (dB) |
|--------------|-----------------|----------------|-------------------|---------------------|--------------------|------------------------------|-------------|
| Horizontal   | *11590          | 43.0           | 35.3              | 41.2                | 48.9               | 54.0                         | -5.1        |

Test Condition : 802.11ac-HT20, SISO, Ant1, Channel 149/6.5Mbps

| Polarization | Frequency (MHz) | Reading (dBμV) | Pre-Amp Gain (dB) | Antenna Factor (dB) | Net at 3m (dBμV/m) | Peak Limit at 3m (dBμV/m) | Margin (dB) |
|--------------|-----------------|----------------|-------------------|---------------------|--------------------|---------------------------|-------------|
| Horizontal   | 11490.000       | 53.6           | 35.3              | 41.2                | 59.5               | 68.2                      | -8.7        |
| Horizontal   | 17235.000       | 55.9           | 33.9              | 39.2                | 61.2               | 68.2                      | -7.0        |
| Horizontal   | 5718.140        | 71.5           | 36.7              | 27.2                | 62.0               | 78.2                      | -16.2       |

| Polarization | Frequency (MHz) | Reading (dBμV) | Pre-Amp Gain (dB) | Antenna Factor (dB) | Net at 3m (dBμV/m) | Average Limit at 3m (dBμV/m) | Margin (dB) |
|--------------|-----------------|----------------|-------------------|---------------------|--------------------|------------------------------|-------------|
| Horizontal   | *11490          | 42.6           | 35.3              | 41.2                | 48.5               | 54.0                         | -5.5        |

Test Condition : 802.11ac-HT20, SISO, Ant1, Channel 157/6.5Mbps

| Polarization | Frequency (MHz) | Reading (dBμV) | Pre-Amp Gain (dB) | Antenna Factor (dB) | Net at 3m (dBμV/m) | Peak Limit at 3m (dBμV/m) | Margin (dB) |
|--------------|-----------------|----------------|-------------------|---------------------|--------------------|---------------------------|-------------|
| Horizontal   | 11570.000       | 56.4           | 35.3              | 41.2                | 62.3               | 68.2                      | -5.9        |
| Horizontal   | 17355.000       | 55.2           | 33.9              | 39.2                | 60.5               | 68.2                      | -7.7        |

| Polarization | Frequency (MHz) | Reading (dBμV) | Pre-Amp Gain (dB) | Antenna Factor (dB) | Net at 3m (dBμV/m) | Average Limit at 3m (dBμV/m) | Margin (dB) |
|--------------|-----------------|----------------|-------------------|---------------------|--------------------|------------------------------|-------------|
| Horizontal   | *11570          | 44.0           | 35.3              | 41.2                | 49.9               | 54.0                         | -4.1        |

Test Condition : 802.11ac-HT20, SISO, Ant1, Channel 165/6.5Mbps

| Polarization | Frequency (MHz) | Reading (dBμV) | Pre-Amp Gain (dB) | Antenna Factor (dB) | Net at 3m (dBμV/m) | Peak Limit at 3m (dBμV/m) | Margin (dB) |
|--------------|-----------------|----------------|-------------------|---------------------|--------------------|---------------------------|-------------|
| Horizontal   | 11650.000       | 54.0           | 35.3              | 41.2                | 59.9               | 68.2                      | -8.3        |
| Horizontal   | 17475.000       | 54.9           | 33.9              | 39.2                | 60.2               | 68.2                      | -8.0        |
| Horizontal   | 5855.916        | 71.3           | 36.7              | 27.7                | 62.3               | 78.2                      | -15.9       |

| Polarization | Frequency (MHz) | Reading (dBμV) | Pre-Amp Gain (dB) | Antenna Factor (dB) | Net at 3m (dBμV/m) | Average Limit at 3m (dBμV/m) | Margin (dB) |
|--------------|-----------------|----------------|-------------------|---------------------|--------------------|------------------------------|-------------|
| Horizontal   | *11650          | 43.7           | 35.3              | 41.2                | 49.6               | 54.0                         | -4.4        |

Test Condition : 802.11ac-HT20, MIMO, Ant1+2+3+4, Channel 149/26Mbps

| Polarization | Frequency (MHz) | Reading (dBμV) | Pre-Amp Gain (dB) | Antenna Factor (dB) | Net at 3m (dBμV/m) | Peak Limit at 3m (dBμV/m) | Margin (dB) |
|--------------|-----------------|----------------|-------------------|---------------------|--------------------|---------------------------|-------------|
| Horizontal   | 11490.000       | 53.5           | 35.3              | 41.2                | 59.4               | 68.2                      | -8.8        |
| Horizontal   | 17235.000       | 55.3           | 33.9              | 39.2                | 60.6               | 68.2                      | -7.6        |
| Horizontal   | 5717.125        | 72.0           | 36.7              | 27.2                | 62.5               | 78.2                      | -15.7       |

| Polarization | Frequency (MHz) | Reading (dBμV) | Pre-Amp Gain (dB) | Antenna Factor (dB) | Net at 3m (dBμV/m) | Average Limit at 3m (dBμV/m) | Margin (dB) |
|--------------|-----------------|----------------|-------------------|---------------------|--------------------|------------------------------|-------------|
| Horizontal   | *11490          | 42.6           | 35.3              | 41.2                | 48.5               | 54.0                         | -5.5        |

Test Condition : 802.11ac-HT20, MIMO, Ant1+2+3+4, Channel 157/26Mbps

| Polarization | Frequency (MHz) | Reading (dBμV) | Pre-Amp Gain (dB) | Antenna Factor (dB) | Net at 3m (dBμV/m) | Peak Limit at 3m (dBμV/m) | Margin (dB) |
|--------------|-----------------|----------------|-------------------|---------------------|--------------------|---------------------------|-------------|
| Horizontal   | 11570.000       | 54.0           | 35.3              | 41.2                | 59.9               | 68.2                      | -8.3        |
| Horizontal   | 17355.000       | 55.1           | 33.9              | 39.2                | 60.4               | 68.2                      | -7.8        |

| Polarization | Frequency (MHz) | Reading (dBμV) | Pre-Amp Gain (dB) | Antenna Factor (dB) | Net at 3m (dBμV/m) | Average Limit at 3m (dBμV/m) | Margin (dB) |
|--------------|-----------------|----------------|-------------------|---------------------|--------------------|------------------------------|-------------|
| Horizontal   | *11570          | 42.6           | 35.3              | 41.2                | 48.5               | 54.0                         | -5.5        |

Test Condition : 802.11ac-HT20, MIMO, Ant1+2+3+4, Channel 165/26Mbps

| Polarization | Frequency (MHz) | Reading (dBμV) | Pre-Amp Gain (dB) | Antenna Factor (dB) | Net at 3m (dBμV/m) | Peak Limit at 3m (dBμV/m) | Margin (dB) |
|--------------|-----------------|----------------|-------------------|---------------------|--------------------|---------------------------|-------------|
| Horizontal   | 11650.000       | 54.6           | 35.3              | 41.2                | 60.5               | 68.2                      | -7.7        |
| Horizontal   | 17475.000       | 55.5           | 33.9              | 39.2                | 60.8               | 68.2                      | -7.4        |
| Horizontal   | 5853.880        | 67.9           | 36.7              | 27.7                | 58.9               | 78.2                      | -19.3       |

| Polarization | Frequency (MHz) | Reading (dB $\mu$ V) | Pre-Amp Gain (dB) | Antenna Factor (dB) | Net at 3m (dB $\mu$ V/m) | Average Limit at 3m (dB $\mu$ V/m) | Margin (dB) |
|--------------|-----------------|----------------------|-------------------|---------------------|--------------------------|------------------------------------|-------------|
| Horizontal   | *11650          | 44.0                 | 35.3              | 41.2                | 49.9                     | 54.0                               | -4.1        |

Test Condition : 802.11ac-HT40, SISO, Ant1, Channel 151/13.5Mbps

| Polarization | Frequency (MHz) | Reading (dB $\mu$ V) | Pre-Amp Gain (dB) | Antenna Factor (dB) | Net at 3m (dB $\mu$ V/m) | Peak Limit at 3m (dB $\mu$ V/m) | Margin (dB) |
|--------------|-----------------|----------------------|-------------------|---------------------|--------------------------|---------------------------------|-------------|
| Horizontal   | 11510.000       | 53.6                 | 35.3              | 41.2                | 59.5                     | 68.2                            | -8.7        |
| Horizontal   | 17265.000       | 55.5                 | 33.9              | 39.2                | 60.8                     | 68.2                            | -7.4        |

| Polarization | Frequency (MHz) | Reading (dB $\mu$ V) | Pre-Amp Gain (dB) | Antenna Factor (dB) | Net at 3m (dB $\mu$ V/m) | Average Limit at 3m (dB $\mu$ V/m) | Margin (dB) |
|--------------|-----------------|----------------------|-------------------|---------------------|--------------------------|------------------------------------|-------------|
| Horizontal   | *11510          | 43.6                 | 35.3              | 41.2                | 49.5                     | 54.0                               | -4.5        |

Test Condition : 802.11ac-HT40, SISO, Ant1, Channel 159/13.5Mbps

| Polarization | Frequency (MHz) | Reading (dB $\mu$ V) | Pre-Amp Gain (dB) | Antenna Factor (dB) | Net at 3m (dB $\mu$ V/m) | Peak Limit at 3m (dB $\mu$ V/m) | Margin (dB) |
|--------------|-----------------|----------------------|-------------------|---------------------|--------------------------|---------------------------------|-------------|
| Horizontal   | 11590.000       | 54.1                 | 35.3              | 41.2                | 60.0                     | 68.2                            | -8.2        |
| Horizontal   | 17385.000       | 54.9                 | 33.9              | 39.2                | 60.2                     | 68.2                            | -8.0        |
| Horizontal   | 5855.860        | 72.2                 | 36.7              | 27.7                | 63.2                     | 78.2                            | -15.0       |

| Polarization | Frequency (MHz) | Reading (dB $\mu$ V) | Pre-Amp Gain (dB) | Antenna Factor (dB) | Net at 3m (dB $\mu$ V/m) | Average Limit at 3m (dB $\mu$ V/m) | Margin (dB) |
|--------------|-----------------|----------------------|-------------------|---------------------|--------------------------|------------------------------------|-------------|
| Horizontal   | *11590          | 43.6                 | 35.3              | 41.2                | 49.5                     | 54.0                               | -4.5        |

Test Condition : 802.11ac-HT40, MIMO, Ant1+2+3+4, Channel 151/54Mbps

| Polarization | Frequency (MHz) | Reading (dBμV) | Pre-Amp Gain (dB) | Antenna Factor (dB) | Net at 3m (dBμV/m) | Peak Limit at 3m (dBμV/m) | Margin (dB) |
|--------------|-----------------|----------------|-------------------|---------------------|--------------------|---------------------------|-------------|
| Horizontal   | 11510.000       | 53.6           | 35.3              | 41.2                | 59.5               | 68.2                      | -8.7        |
| Horizontal   | 17265.000       | 56.2           | 33.9              | 39.2                | 61.5               | 68.2                      | -6.7        |
| Horizontal   | 5722.880        | 73.3           | 36.8              | 26.5                | 63.0               | 78.2                      | -15.2       |

| Polarization | Frequency (MHz) | Reading (dBμV) | Pre-Amp Gain (dB) | Antenna Factor (dB) | Net at 3m (dBμV/m) | Average Limit at 3m (dBμV/m) | Margin (dB) |
|--------------|-----------------|----------------|-------------------|---------------------|--------------------|------------------------------|-------------|
| Horizontal   | *11510          | 40.8           | 35.3              | 41.2                | 46.7               | 54.0                         | -7.3        |

Test Condition : 802.11ac-HT40, MIMO, Ant1+2+3+4, Channel 159/54Mbps

| Polarization | Frequency (MHz) | Reading (dBμV) | Pre-Amp Gain (dB) | Antenna Factor (dB) | Net at 3m (dBμV/m) | Peak Limit at 3m (dBμV/m) | Margin (dB) |
|--------------|-----------------|----------------|-------------------|---------------------|--------------------|---------------------------|-------------|
| Horizontal   | 11590.000       | 54.0           | 35.3              | 41.2                | 59.9               | 68.2                      | -8.3        |
| Horizontal   | 17385.000       | 55.2           | 33.9              | 39.2                | 60.5               | 68.2                      | -7.7        |
| Horizontal   | 5852.106        | 71.0           | 36.7              | 27.7                | 62.0               | 78.2                      | -16.2       |

| Polarization | Frequency (MHz) | Reading (dBμV) | Pre-Amp Gain (dB) | Antenna Factor (dB) | Net at 3m (dBμV/m) | Average Limit at 3m (dBμV/m) | Margin (dB) |
|--------------|-----------------|----------------|-------------------|---------------------|--------------------|------------------------------|-------------|
| Horizontal   | *11590          | 43.5           | 35.3              | 41.2                | 49.4               | 54.0                         | -4.6        |

Test Condition : 802.11ac, SISO, Ant1, Channel 155/29.3Mbps

| Polarization | Frequency (MHz) | Reading (dBμV) | Pre-Amp Gain (dB) | Antenna Factor (dB) | Net at 3m (dBμV/m) | Peak Limit at 3m (dBμV/m) | Margin (dB) |
|--------------|-----------------|----------------|-------------------|---------------------|--------------------|---------------------------|-------------|
| Horizontal   | 11550.000       | 54.0           | 35.3              | 41.2                | 59.9               | 68.2                      | -8.3        |
| Horizontal   | 17325.000       | 55.2           | 33.9              | 39.2                | 60.5               | 68.2                      | -7.7        |
| Horizontal   | 5721.395        | 71.4           | 36.8              | 26.5                | 61.1               | 78.2                      | -17.1       |
| Horizontal   | 5858.068        | 59.5           | 36.3              | 38.6                | 61.8               | 78.2                      | -16.4       |

| Polarization | Frequency (MHz) | Reading (dBμV) | Pre-Amp Gain (dB) | Antenna Factor (dB) | Net at 3m (dBμV/m) | Average Limit at 3m (dBμV/m) | Margin (dB) |
|--------------|-----------------|----------------|-------------------|---------------------|--------------------|------------------------------|-------------|
| Horizontal   | *11550          | 41.0           | 35.3              | 41.2                | 46.9               | 54.0                         | -7.1        |

Test Condition : 802.11ac, MIMO, Ant1+2+3+4, Channel 155/117.2Mbps

| Polarization | Frequency (MHz) | Reading (dB $\mu$ V) | Pre-Amp Gain (dB) | Antenna Factor (dB) | Net at 3m (dB $\mu$ V/m) | Peak Limit at 3m (dB $\mu$ V/m) | Margin (dB) |
|--------------|-----------------|----------------------|-------------------|---------------------|--------------------------|---------------------------------|-------------|
| Horizontal   | 11550.000       | 54.3                 | 35.3              | 41.2                | 60.2                     | 68.2                            | -8.0        |
| Horizontal   | 17325.000       | 55.2                 | 33.9              | 39.2                | 60.5                     | 68.2                            | -7.7        |
| Horizontal   | 5722.140        | 72.8                 | 36.8              | 26.5                | 62.5                     | 78.2                            | -15.7       |
| Horizontal   | 5851.735        | 60.5                 | 36.3              | 38.6                | 62.8                     | 78.2                            | -15.4       |

| Polarization | Frequency (MHz) | Reading (dB $\mu$ V) | Pre-Amp Gain (dB) | Antenna Factor (dB) | Net at 3m (dB $\mu$ V/m) | Average Limit at 3m (dB $\mu$ V/m) | Margin (dB) |
|--------------|-----------------|----------------------|-------------------|---------------------|--------------------------|------------------------------------|-------------|
| Horizontal   | *11550          | 39.9                 | 35.3              | 41.2                | 45.8                     | 54.0                               | -8.2        |

- \* Emission within the restricted band meets the requirement of section 15.205. The corresponding limit as per 15.209 is based on Quasi peak limit for frequencies below 1000 MHz and average limit for frequencies over 1000 MHz. The radio frequency emissions above 1GHz also meet corresponding 20dB permitted peak limit with a peak detector function.



**7. Power Line Conducted Emission test**

**7.1 Operating environment**

Temperature: 23 °C  
 Relative Humidity: 55 %  
 Atmospheric Pressure 1023 hPa

**7.2 Test setup & procedure**

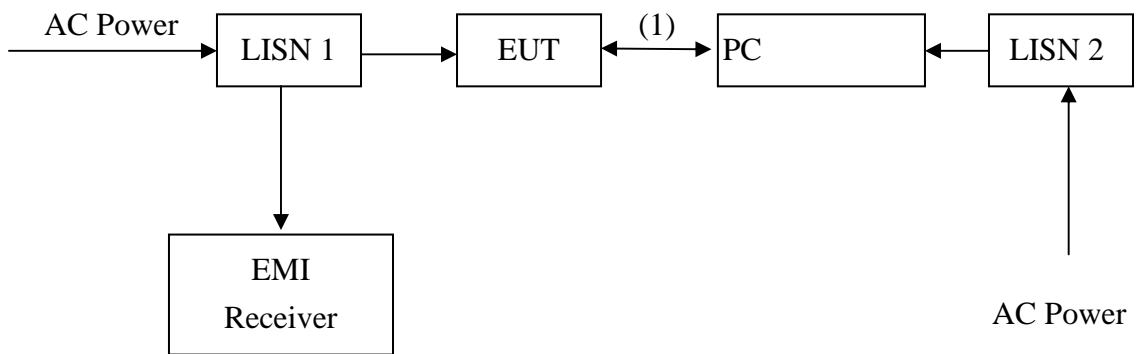

The EUT are connected to the main power through a line impedance stabilization network (LISN). This provides a 50 ohm/50 uH coupling impedance for the measuring equipment. The peripheral devices are also connected to the main power through a LISN that provides a 50 ohm/50 uH coupling impedance with 50 ohm termination.

Both sides (Line and Neutral) of AC line are checked for maximum conducted interference. In order to find the maximum emission, the relative positions of equipment and all of the interface cables must be changed according to ANSI C63.10/2013 on conducted measurement.

The bandwidth of the field strength meter (R & S Test Receiver ESCI 30) is set at 9 kHz.

### 7.3 Limit

| Freq.<br>(MHz) | Conducted Limit (dBuV) |          |
|----------------|------------------------|----------|
|                | Q.P.                   | Ave.     |
| 0.15~0.50      | 66 – 56*               | 56 – 46* |
| 0.50~5.00      | 56                     | 46       |
| 5.00~30.0      | 60                     | 50       |

\*Decreases with the logarithm of the frequency.

### 7.4 Power Line Conducted Emission test data

The worst case test was performed on EUT under 802.11 ac-HT40 Link

Phase: Live  
 Test Condition: 802.11ac-HT40, MIMO, 38/54Mbps

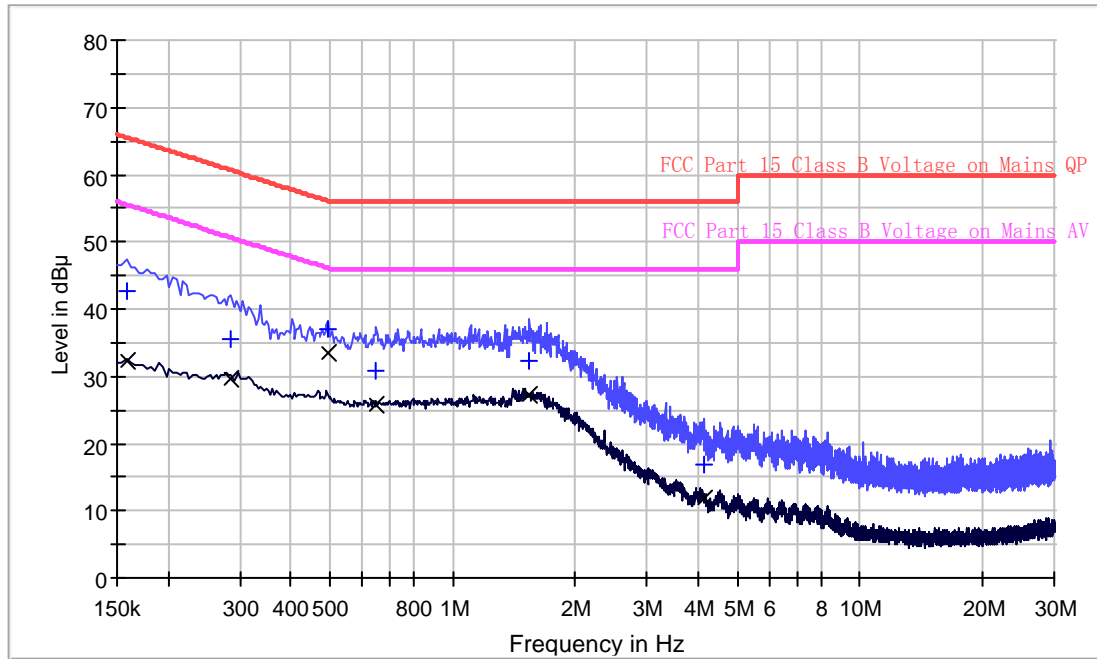

#### Result Table QP

| Frequency (MHz) | QuasiPeak (dB $\mu$ V) | Bandwidth (kHz) | Line | Corr. (dB) | Margin (dB) | Limit (dB $\mu$ V) |
|-----------------|------------------------|-----------------|------|------------|-------------|--------------------|
| 0.158           | 42.5                   | 9.000           | L1   | 9.5        | 23.1        | 65.6               |
| 0.286           | 35.6                   | 9.000           | L1   | 9.6        | 25.0        | 60.6               |
| 0.494           | 36.9                   | 9.000           | L1   | 9.6        | 19.2        | 56.1               |
| 0.650           | 30.8                   | 9.000           | L1   | 9.6        | 25.2        | 56.0               |
| 1.546           | 32.2                   | 9.000           | L1   | 9.6        | 23.8        | 56.0               |
| 4.158           | 17.0                   | 9.000           | L1   | 9.6        | 39.0        | 56.0               |

#### Result Table AV

| Frequency (MHz) | Average (dB $\mu$ V) | Bandwidth (kHz) | Line | Corr. (dB) | Margin (dB) | Limit (dB $\mu$ V) |
|-----------------|----------------------|-----------------|------|------------|-------------|--------------------|
| 0.158           | 32.3                 | 9.000           | L1   | 9.5        | 23.3        | 55.6               |
| 0.286           | 29.5                 | 9.000           | L1   | 9.6        | 21.1        | 50.6               |
| 0.494           | 33.6                 | 9.000           | L1   | 9.6        | 12.5        | 46.1               |
| 0.650           | 25.7                 | 9.000           | L1   | 9.6        | 20.3        | 46.0               |
| 1.546           | 27.1                 | 9.000           | L1   | 9.6        | 18.9        | 46.0               |
| 4.158           | 11.8                 | 9.000           | L1   | 9.6        | 34.2        | 46.0               |

Phase: : Neutral  
 Test Condition: : 802.11ac-HT40, MIMO, 38/54Mbps

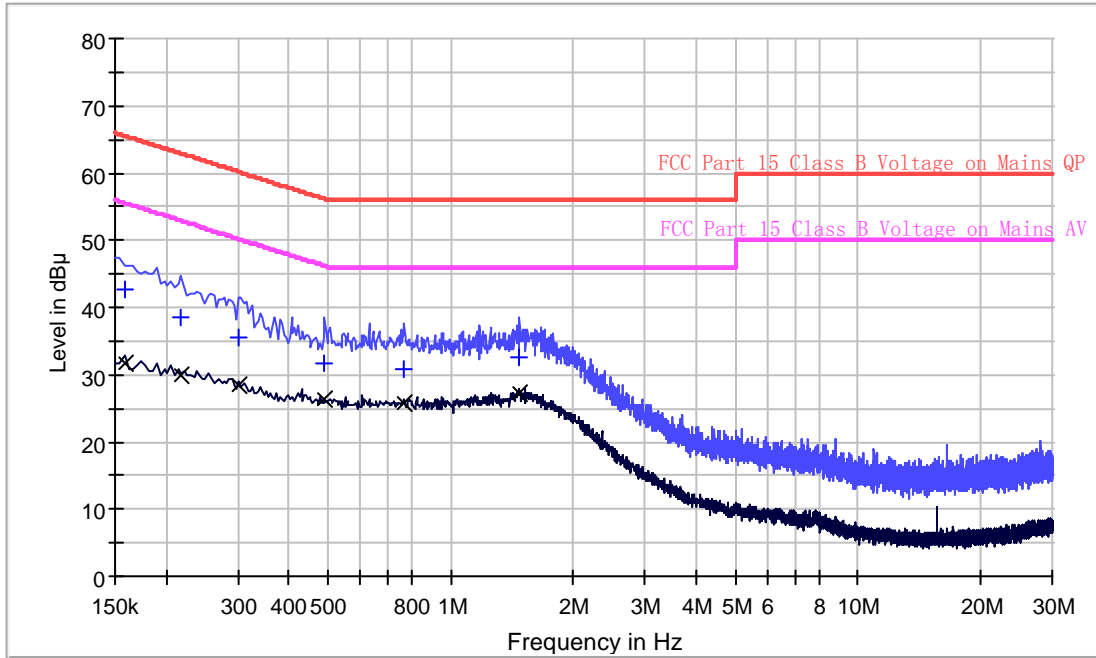

### Result Table QP

| Frequency (MHz) | QuasiPeak (dB $\mu$ V) | Bandwidth (kHz) | Line | Corr. (dB) | Margin (dB) | Limit (dB $\mu$ V) |
|-----------------|------------------------|-----------------|------|------------|-------------|--------------------|
| 0.158           | 42.6                   | 9.000           | N    | 9.6        | 23.0        | 65.6               |
| 0.218           | 38.6                   | 9.000           | N    | 9.6        | 24.3        | 62.9               |
| 0.302           | 35.7                   | 9.000           | N    | 9.6        | 24.5        | 60.2               |
| 0.490           | 31.8                   | 9.000           | N    | 9.6        | 24.4        | 56.2               |
| 0.770           | 30.7                   | 9.000           | N    | 9.6        | 25.3        | 56.0               |
| 1.478           | 32.5                   | 9.000           | N    | 9.6        | 23.5        | 56.0               |

### Result Table AV

| Frequency (MHz) | Average (dB $\mu$ V) | Bandwidth (kHz) | Line | Corr. (dB) | Margin (dB) | Limit (dB $\mu$ V) |
|-----------------|----------------------|-----------------|------|------------|-------------|--------------------|
| 0.158           | 31.7                 | 9.000           | N    | 9.6        | 23.9        | 55.6               |
| 0.218           | 29.9                 | 9.000           | N    | 9.6        | 23.0        | 52.9               |
| 0.302           | 28.3                 | 9.000           | N    | 9.6        | 21.9        | 50.2               |
| 0.490           | 26.3                 | 9.000           | N    | 9.6        | 19.9        | 46.2               |
| 0.770           | 25.7                 | 9.000           | N    | 9.6        | 20.3        | 46.0               |
| 1.478           | 27.3                 | 9.000           | N    | 9.6        | 18.7        | 46.0               |

**8. Frequency Stability Test**

**8.1 Test setup & procedure**

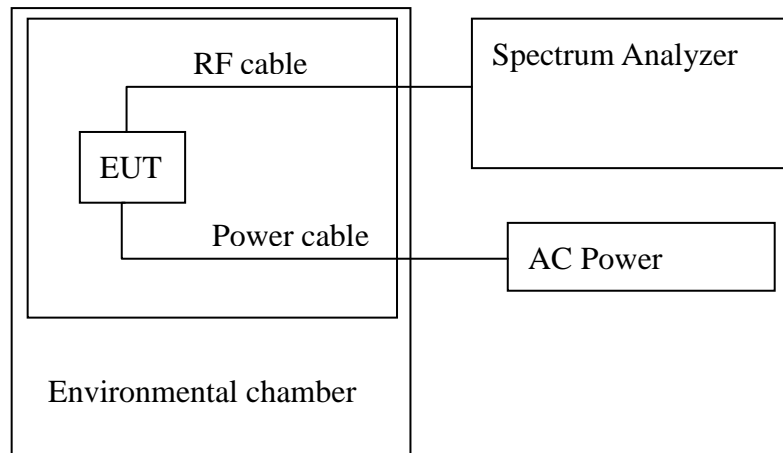

Note1: The frequency stability is measured with the temperature variation range of 0°C to +40°C (10°C increment), and voltage supply variation range of 85% to 115% of nominal AC supply voltage.

2: To ensure emission at the band-edge is maintained within the authorized band, the frequency 802.11a/n-HT20/40/ac-HT20/40/80 channel 36, 48, 38, 46, 42, 149, 165, 151, 159, 155 are selected to test and the worst case of ant1 was reported.

**8.2 Frequency Stability Test Data**

20°C is taken as temperature in normal condition.

Model: 802.11a, Operation frequency: 5180MHz, Channel: 36, Rate: 6Mbps

| Input voltage (VAC) | Temperature (°C) | Measured Frequency (MHz) | Frequency deviation (Hz) | Result |
|---------------------|------------------|--------------------------|--------------------------|--------|
| 120                 | 0                | 5180.000125              | 125                      | Pass   |
|                     | +10              | 5179.999574              | -426                     | Pass   |
|                     | +20              | 5179.999836              | -164                     | Pass   |
|                     | +30              | 5179.999516              | -494                     | Pass   |
|                     | +40              | 5179.999920              | -80                      | Pass   |
| 102                 | +20              | 5180.000115              | 115                      | Pass   |
| 138                 | +20              | 5180.000112              | 112                      | Pass   |

Model: 802.11a, Operation frequency: 5240MHz, Channel: 48, Rate: 6Mbps

| Input voltage (VAC) | Temperature (°C) | Measured Frequency (MHz) | Frequency deviation (Hz) | Result |
|---------------------|------------------|--------------------------|--------------------------|--------|
| 120                 | 0                | 5240.000134              | 134                      | Pass   |
|                     | +10              | 5240.000155              | 155                      | Pass   |
|                     | +20              | 5240.000168              | 168                      | Pass   |
|                     | +30              | 5240.000112              | 112                      | Pass   |
|                     | +40              | 5240.000183              | 183                      | Pass   |
| 102                 | +20              | 5240.000215              | 215                      | Pass   |
| 138                 | +20              | 5240.000228              | 228                      | Pass   |

Model: 802.11n-HT20, Operation frequency: 5180MHz, Channel: 36, Rate: 6.5Mbps

| Input voltage (VAC) | Temperature (°C) | Measured Frequency (MHz) | Frequency deviation (Hz) | Result |
|---------------------|------------------|--------------------------|--------------------------|--------|
| 120                 | 0                | 5180.000125              | 125                      | Pass   |
|                     | +10              | 5179.999524              | -476                     | Pass   |
|                     | +20              | 5179.999860              | -140                     | Pass   |
|                     | +30              | 5179.999523              | -477                     | Pass   |
|                     | +40              | 5179.999576              | -424                     | Pass   |
| 102                 | +20              | 5180.000135              | 135                      | Pass   |
| 138                 | +20              | 5180.000126              | 126                      | Pass   |

Model: 802.11n-HT20, Operation frequency: 5240MHz, Channel: 48, Rate: 6.5Mbps

| Input voltage (VAC) | Temperature (°C) | Measured Frequency (MHz) | Frequency deviation (Hz) | Result |
|---------------------|------------------|--------------------------|--------------------------|--------|
| 120                 | 0                | 5240.000125              | 125                      | Pass   |
|                     | +10              | 5240.000121              | 121                      | Pass   |
|                     | +20              | 5240.000154              | 154                      | Pass   |
|                     | +30              | 5240.000125              | 125                      | Pass   |
|                     | +40              | 5240.000129              | 129                      | Pass   |
| 102                 | +20              | 5240.000181              | 181                      | Pass   |
| 138                 | +20              | 5240.000146              | 146                      | Pass   |

Model: 802.11n-HT40, Operation frequency: 5190MHz, Channel: 38, Rate: 13.5Mbps

| Input voltage (VAC) | Temperature (°C) | Measured Frequency (MHz) | Frequency deviation (Hz) | Result |
|---------------------|------------------|--------------------------|--------------------------|--------|
| 120                 | 0                | 5190.000184              | 184                      | Pass   |
|                     | +10              | 5189.999260              | -740                     | Pass   |
|                     | +20              | 5189.999415              | -585                     | Pass   |
|                     | +30              | 5189.999295              | -705                     | Pass   |
|                     | +40              | 5190.000194              | 194                      | Pass   |
| 102                 | +20              | 5190.000254              | 254                      | Pass   |
| 138                 | +20              | 5190.000188              | 188                      | Pass   |

Model: 802.11n-HT40, Operation frequency: 5230MHz, Channel: 46, Rate: 13.5Mbps

| Input voltage (VAC) | Temperature (°C) | Measured Frequency (MHz) | Frequency deviation (Hz) | Result |
|---------------------|------------------|--------------------------|--------------------------|--------|
| 120                 | 0                | 5230.000251              | 251                      | Pass   |
|                     | +10              | 5230.000285              | 285                      | Pass   |
|                     | +20              | 5230.000266              | 266                      | Pass   |
|                     | +30              | 5230.000198              | 198                      | Pass   |
|                     | +40              | 5230.000126              | 126                      | Pass   |
| 102                 | +20              | 5230.000256              | 256                      | Pass   |
| 138                 | +20              | 5230.000298              | 298                      | Pass   |

Model: 802.11ac-HT20, Operation frequency: 5180MHz, Channel: 36, Rate: 6.5Mbps

| Input voltage (VAC) | Temperature (°C) | Measured Frequency (MHz) | Frequency deviation (Hz) | Result |
|---------------------|------------------|--------------------------|--------------------------|--------|
| 120                 | 0                | 5180.000126              | 126                      | Pass   |
|                     | +10              | 5179.999544              | -456                     | Pass   |
|                     | +20              | 5179.999857              | -143                     | Pass   |
|                     | +30              | 5179.999508              | -492                     | Pass   |
|                     | +40              | 5179.999258              | -742                     | Pass   |
| 102                 | +20              | 5180.000185              | 185                      | Pass   |
| 138                 | +20              | 5180.000159              | 159                      | Pass   |

Model: 802.11ac-HT20, Operation frequency: 5240MHz, Channel: 48, Rate: 6.5Mbps

| Input voltage (VAC) | Temperature (°C) | Measured Frequency (MHz) | Frequency deviation (Hz) | Result |
|---------------------|------------------|--------------------------|--------------------------|--------|
| 120                 | 0                | 5240.000198              | 198                      | Pass   |
|                     | +10              | 5240.000158              | 158                      | Pass   |
|                     | +20              | 5240.000146              | 146                      | Pass   |
|                     | +30              | 5240.000125              | 125                      | Pass   |
|                     | +40              | 5240.000188              | 188                      | Pass   |
| 102                 | +20              | 5240.000168              | 168                      | Pass   |
| 138                 | +20              | 5240.000149              | 149                      | Pass   |

Model: 802.11ac-HT40, Operation frequency: 5190MHz, Channel: 38, Rate: 13.5Mbps

| Input voltage (VAC) | Temperature (°C) | Measured Frequency (MHz) | Frequency deviation (Hz) | Result |
|---------------------|------------------|--------------------------|--------------------------|--------|
| 120                 | 0                | 5190.000124              | 124                      | Pass   |
|                     | +10              | 5189.999254              | -746                     | Pass   |
|                     | +20              | 5189.999385              | -615                     | Pass   |
|                     | +30              | 5189.999295              | -715                     | Pass   |
|                     | +40              | 5190.000191              | 191                      | Pass   |
| 102                 | +20              | 5190.000210              | 210                      | Pass   |
| 138                 | +20              | 5190.000196              | 196                      | Pass   |

Model: 802.11ac-HT40, Operation frequency: 5230MHz, Channel: 46, Rate: 13.5Mbps

| Input voltage (VAC) | Temperature (°C) | Measured Frequency (MHz) | Frequency deviation (Hz) | Result |
|---------------------|------------------|--------------------------|--------------------------|--------|
| 120                 | 0                | 5230.000246              | 246                      | Pass   |
|                     | +10              | 5230.000298              | 298                      | Pass   |
|                     | +20              | 5230.000286              | 286                      | Pass   |
|                     | +30              | 5230.000267              | 267                      | Pass   |
|                     | +40              | 5230.000155              | 155                      | Pass   |
| 102                 | +20              | 5230.000248              | 248                      | Pass   |
| 138                 | +20              | 5230.000296              | 296                      | Pass   |

Model: 802.11ac-HT80, Operation frequency: 5210MHz, Channel: 42, Rate: 29.3Mbps

| Input voltage (VAC) | Temperature (°C) | Measured Frequency (MHz) | Frequency deviation (Hz) | Result |
|---------------------|------------------|--------------------------|--------------------------|--------|
| 120                 | 0                | 5210.000225              | 225                      | Pass   |
|                     | +10              | 5210.000156              | 156                      | Pass   |
|                     | +20              | 5210.000198              | 198                      | Pass   |
|                     | +30              | 5210.000156              | 156                      | Pass   |
|                     | +40              | 5210.000226              | 226                      | Pass   |
| 102                 | +20              | 5210.000290              | 290                      | Pass   |
| 138                 | +20              | 5210.000178              | 178                      | Pass   |

Model: 802.11a, Operation frequency: 5745MHz, Channel: 149, Rate: 6Mbps

| Input voltage (VAC) | Temperature (°C) | Measured Frequency (MHz) | Frequency deviation (Hz) | Result |
|---------------------|------------------|--------------------------|--------------------------|--------|
| 120                 | 0                | 5745.000195              | 195                      | Pass   |
|                     | +10              | 5745.000165              | 165                      | Pass   |
|                     | +20              | 5745.000124              | 124                      | Pass   |
|                     | +30              | 5745.000255              | 255                      | Pass   |
|                     | +40              | 5745.000211              | 211                      | Pass   |
| 102                 | +20              | 5745.000199              | 199                      | Pass   |
| 138                 | +20              | 5745.000122              | 122                      | Pass   |

Model: 802.11a, Operation frequency: 5825MHz, Channel: 165, Rate: 6Mbps

| Input voltage (VAC) | Temperature (°C) | Measured Frequency (MHz) | Frequency deviation (Hz) | Result |
|---------------------|------------------|--------------------------|--------------------------|--------|
| 120                 | 0                | 5825.000165              | 165                      | Pass   |
|                     | +10              | 5825.000246              | 246                      | Pass   |
|                     | +20              | 5825.000218              | 218                      | Pass   |
|                     | +30              | 5825.000139              | 139                      | Pass   |
|                     | +40              | 5825.000228              | 228                      | Pass   |
| 102                 | +20              | 5825.000258              | 258                      | Pass   |
| 138                 | +20              | 5825.000255              | 255                      | Pass   |

Model: 802.11n-HT20, Operation frequency: 5745MHz, Channel: 149, Rate: 6.5Mbps

| Input voltage (VAC) | Temperature (°C) | Measured Frequency (MHz) | Frequency deviation (Hz) | Result |
|---------------------|------------------|--------------------------|--------------------------|--------|
| 120                 | 0                | 5745.000145              | 145                      | Pass   |
|                     | +10              | 5745.000243              | 243                      | Pass   |
|                     | +20              | 5745.000225              | 225                      | Pass   |
|                     | +30              | 5745.000196              | 196                      | Pass   |
|                     | +40              | 5745.000159              | 159                      | Pass   |
| 102                 | +20              | 5745.000245              | 245                      | Pass   |
| 138                 | +20              | 5745.000141              | 141                      | Pass   |



Model: 802.11n-HT20, Operation frequency: 5825MHz, Channel: 165, Rate: 6.5Mbps

| Input voltage (VAC) | Temperature (°C) | Measured Frequency (MHz) | Frequency deviation (Hz) | Result |
|---------------------|------------------|--------------------------|--------------------------|--------|
| 120                 | 0                | 5825.000228              | 228                      | Pass   |
|                     | +10              | 5825.000242              | 242                      | Pass   |
|                     | +20              | 5825.000129              | 129                      | Pass   |
|                     | +30              | 5825.000216              | 216                      | Pass   |
|                     | +40              | 5825.000165              | 165                      | Pass   |
| 102                 | +20              | 5825.000243              | 243                      | Pass   |
| 138                 | +20              | 5825.000125              | 125                      | Pass   |

Model: 802.11n-HT40, Operation frequency: 5755MHz, Channel: 151, Rate: 13.5Mbps

| Input voltage (VAC) | Temperature (°C) | Measured Frequency (MHz) | Frequency deviation (Hz) | Result |
|---------------------|------------------|--------------------------|--------------------------|--------|
| 120                 | 0                | 5754.999826              | -174                     | Pass   |
|                     | +10              | 5754.999858              | -142                     | Pass   |
|                     | +20              | 5754.999825              | -175                     | Pass   |
|                     | +30              | 5754.999877              | -123                     | Pass   |
|                     | +40              | 5754.999845              | -155                     | Pass   |
| 102                 | +20              | 5754.999856              | -144                     | Pass   |
| 138                 | +20              | 5754.999844              | -156                     | Pass   |

Model: 802.11n-HT40, Operation frequency: 5795MHz, Channel: 159, Rate: 13.5Mbps

| Input voltage (VAC) | Temperature (°C) | Measured Frequency (MHz) | Frequency deviation (Hz) | Result |
|---------------------|------------------|--------------------------|--------------------------|--------|
| 120                 | 0                | 5795.000266              | 266                      | Pass   |
|                     | +10              | 5795.000278              | 278                      | Pass   |
|                     | +20              | 5795.000293              | 293                      | Pass   |
|                     | +30              | 5795.000216              | 216                      | Pass   |
|                     | +40              | 5795.000276              | 276                      | Pass   |
| 102                 | +20              | 5795.000146              | 146                      | Pass   |
| 138                 | +20              | 5795.000252              | 252                      | Pass   |

Model: 802.11n-HT20, Operation frequency: 5745MHz, Channel: 149, Rate: 6.5Mbps

| Input voltage (VAC) | Temperature (°C) | Measured Frequency (MHz) | Frequency deviation (Hz) | Result |
|---------------------|------------------|--------------------------|--------------------------|--------|
| 120                 | 0                | 5745.000148              | 148                      | Pass   |
|                     | +10              | 5745.000275              | 275                      | Pass   |
|                     | +20              | 5745.000222              | 222                      | Pass   |
|                     | +30              | 5745.000236              | 236                      | Pass   |
|                     | +40              | 5745.000465              | 465                      | Pass   |
| 102                 | +20              | 5745.000215              | 215                      | Pass   |
| 138                 | +20              | 5745.000235              | 235                      | Pass   |

Model: 802.11n-HT20, Operation frequency: 5825MHz, Channel: 165, Rate: 6.5Mbps

| Input voltage (VAC) | Temperature (°C) | Measured Frequency (MHz) | Frequency deviation (Hz) | Result |
|---------------------|------------------|--------------------------|--------------------------|--------|
| 120                 | 0                | 5825.000335              | 335                      | Pass   |
|                     | +10              | 5825.000346              | 346                      | Pass   |
|                     | +20              | 5825.000217              | 217                      | Pass   |
|                     | +30              | 5825.000255              | 255                      | Pass   |
|                     | +40              | 5825.000236              | 236                      | Pass   |
| 102                 | +20              | 5825.000215              | 215                      | Pass   |
| 138                 | +20              | 5825.000309              | 309                      | Pass   |

Model: 802.11n-HT40, Operation frequency: 5755MHz, Channel: 151, Rate: 13.5Mbps

| Input voltage (VAC) | Temperature (°C) | Measured Frequency (MHz) | Frequency deviation (Hz) | Result |
|---------------------|------------------|--------------------------|--------------------------|--------|
| 120                 | 0                | 5754.999295              | -705                     | Pass   |
|                     | +10              | 5754.999296              | -704                     | Pass   |
|                     | +20              | 5754.999725              | -275                     | Pass   |
|                     | +30              | 5754.999276              | -724                     | Pass   |
|                     | +40              | 5754.999027              | -973                     | Pass   |
| 102                 | +20              | 5755.000180              | 180                      | Pass   |
| 138                 | +20              | 5755.000239              | 239                      | Pass   |

Model: 802.11n-HT40, Operation frequency: 5795MHz, Channel: 159, Rate: 13.5Mbps

| Input voltage (VAC) | Temperature (°C) | Measured Frequency (MHz) | Frequency deviation (Hz) | Result |
|---------------------|------------------|--------------------------|--------------------------|--------|
| 120                 | 0                | 5795.000312              | 312                      | Pass   |
|                     | +10              | 5795.000245              | 245                      | Pass   |
|                     | +20              | 5795.000218              | 218                      | Pass   |
|                     | +30              | 5795.000225              | 225                      | Pass   |
|                     | +40              | 5795.000299              | 299                      | Pass   |
| 102                 | +20              | 5795.000215              | 215                      | Pass   |
| 138                 | +20              | 5795.000214              | 214                      | Pass   |

Model: 802.11ac-HT20, Operation frequency: 5745MHz, Channel: 149, Rate: 6.5Mbps

| Input voltage (VAC) | Temperature (°C) | Measured Frequency (MHz) | Frequency deviation (Hz) | Result |
|---------------------|------------------|--------------------------|--------------------------|--------|
| 120                 | 0                | 5745.000155              | 155                      | Pass   |
|                     | +10              | 5745.000235              | 235                      | Pass   |
|                     | +20              | 5745.000245              | 245                      | Pass   |
|                     | +30              | 5745.000245              | 245                      | Pass   |
|                     | +40              | 5745.000256              | 256                      | Pass   |
| 102                 | +20              | 5745.000258              | 258                      | Pass   |
| 138                 | +20              | 5745.000221              | 221                      | Pass   |

Model: 802.11ac-HT20, Operation frequency: 5825MHz, Channel: 165, Rate: 6.5Mbps

| Input voltage (VAC) | Temperature (°C) | Measured Frequency (MHz) | Frequency deviation (Hz) | Result |
|---------------------|------------------|--------------------------|--------------------------|--------|
| 120                 | 0                | 5825.000204              | 204                      | Pass   |
|                     | +10              | 5825.000236              | 236                      | Pass   |
|                     | +20              | 5825.000156              | 156                      | Pass   |
|                     | +30              | 5825.000246              | 246                      | Pass   |
|                     | +40              | 5825.000235              | 235                      | Pass   |
| 102                 | +20              | 5825.000226              | 226                      | Pass   |
| 138                 | +20              | 5825.000246              | 246                      | Pass   |

Model: 802.11n-HT40, Operation frequency: 5755MHz, Channel: 151, Rate: 13.5Mbps

| Input voltage (VAC) | Temperature (°C) | Measured Frequency (MHz) | Frequency deviation (Hz) | Result |
|---------------------|------------------|--------------------------|--------------------------|--------|
| 120                 | 0                | 5754.999295              | -705                     | Pass   |
|                     | +10              | 5754.999227              | -773                     | Pass   |
|                     | +20              | 5754.999716              | -284                     | Pass   |
|                     | +30              | 5754.999275              | -725                     | Pass   |
|                     | +40              | 5754.999128              | -872                     | Pass   |
| 102                 | +20              | 5755.000265              | 265                      | Pass   |
| 138                 | +20              | 5755.000255              | 255                      | Pass   |

Model: 802.11ac-HT40, Operation frequency: 5795MHz, Channel: 159, Rate: 13.5Mbps

| Input voltage (VAC) | Temperature (°C) | Measured Frequency (MHz) | Frequency deviation (Hz) | Result |
|---------------------|------------------|--------------------------|--------------------------|--------|
| 120                 | 0                | 5795.000224              | 224                      | Pass   |
|                     | +10              | 5795.000248              | 248                      | Pass   |
|                     | +20              | 5795.000215              | 215                      | Pass   |
|                     | +30              | 5795.000235              | 235                      | Pass   |
|                     | +40              | 5795.000278              | 278                      | Pass   |
| 102                 | +20              | 5795.000158              | 158                      | Pass   |
| 138                 | +20              | 5795.000218              | 218                      | Pass   |

Model: 802.11ac-HT80 Operation frequency: 5775MHz, Channel: 155, Rate: 29.3Mbps

| Input voltage (VAC) | Temperature (°C) | Measured Frequency (MHz) | Frequency deviation (Hz) | Result |
|---------------------|------------------|--------------------------|--------------------------|--------|
| 120                 | 0                | 5775.000266              | 266                      | Pass   |
|                     | +10              | 5775.000257              | 257                      | Pass   |
|                     | +20              | 5775.000245              | 245                      | Pass   |
|                     | +30              | 5775.000235              | 235                      | Pass   |
|                     | +40              | 5775.000237              | 237                      | Pass   |
| 102                 | +20              | 5775.000125              | 125                      | Pass   |
| 138                 | +20              | 5775.000216              | 216                      | Pass   |

Note: All emissions are maintained within the band of operation under all conditions of normal operation as specified in the user manual. It fulfills the requirement of 15.407(g).

Appendix A: Test equipment list

| Equipment No. | Equipment  | Manufacturer    | Model No.        | Serial No. | Cal. Date   | Due Date    |
|---------------|--|-----------------|------------------|------------|-------------|-------------|
| SZ182-02      | RF Power Meter   | Anritsu         | ML2496A          | 1302005    | 23-May-2016 | 23-May-2017 |
| SZ182-02-01   | Pulse Power Sensor   | Anritsu         | MA2411B          | 1207429    | 23-May-2016 | 23-May-2017 |
| SZ070-24      | Open Switch and Control Unit with TS8997 option for power measurement test | R&S             | OSP120+B157      | --         | 8-Apr-2016  | 8-Oct-2016  |
| SZ061-12      | BiConiLog Antenna  | ETS             | 3142E            | 00166158   | 15-Sep-2015 | 15-Sep-2016 |
| SZ061-06      | Active Loop Antenna  | Electro-Metrics | EM-6876          | 217        | 29-Apr-2016 | 29-Apr-2017 |
| SZ061-09      | Horn Antenna   | ETS             | 3115             | 00092346   | 31-Oct-2015 | 31-Oct-2016 |
| SZ061-07      | Pyramidal Horn Antenna   | ETS             | 3160-09          | 00083067   | 29-Mar-2016 | 29-Mar-2017 |
| SZ061-13      | Pyramidal Horn Antenna   | ETS             | 3160-10          | 00084329   | 03-Sep-2015 | 03-Sep-2016 |
| SZ185-01      | EMI Receiver   | R&S             | ESCI             | 100547     | 23-Jan-2016 | 23-Jan-2017 |
| SZ056-06      | EXA Spectrum Analyzer  | R&S             | FSV40            | 101101     | 2-Jul-2016  | 2-Jul-2017  |
| SZ181-04      | Preamplifier   | Agilent         | 8449B            | 3008A02474 | 23-Jan-2016 | 23-Jan-2017 |
| SZ188-01      | Anechoic Chamber   | ETS             | RFD-F/A-100      | 4102       | 16-Apr-2016 | 16-Apr-2018 |
| SZ062-02      | RF Cable   | RADIALL         | RG 213U          | --         | 30-Jun-2016 | 30-Dec-2016 |
| SZ062-05      | RF Cable   | RADIALL         | 0.04-26.5GHz     | --         | 6-Apr-2016  | 6-Oct-2016  |
| SZ062-12      | RF Cable   | RADIALL         | 0.04-26.5GHz     | --         | 6-Apr-2016  | 6-Oct-2016  |
| SZ067-21      | Notch Filter   | Micro-Tronics   | High-pass filter | --         | 23-Jan-2016 | 23-Jan-2017 |
| SZ067-04      | Notch Filter   | Micro-Tronics   | BRM50702-02      | --         | 6-Apr-2016  | 6-Oct-2016  |
| SZ185-02      | EMI Test Receiver  | R&S             | ESCI             | 100692     | 23-May-2016 | 23-May-2017 |
| SZ187-01      | Two-Line V-Network   | R&S             | ENV216           | 100072     | 3-Nov-2015  | 3-Nov-2016  |
| SZ187-02      | Two-Line V-Network   | R&S             | ENV216           | 100073     | 3-Nov-2015  | 3-Nov-2016  |
| SZ188-03      | Shielding Room   | ETS             | RFD-100          | 4100       | 1-Jul-2016  | 1-Jul-2017  |
| SZ016-12      | Programmable Temperature & Humidity Chamber                                | Taili           | MHK-120NK        | AB0105     | 23-Jan-2016 | 23-Jan-2017 |
| SZ006-11      | AC Power Source  | Apcpowers       | AFC-11005G       | F311040110 | 23-Mar-2016 | 23-Sep-2016 |

Expanded uncertainty of radiated emission measurement is  $\pm 4.9$  dB.

Expanded uncertainty of conducted emission measurement is  $\pm 3.6$  dB.