



# Shenzhen General Testing & Inspection Technology Co.,Ltd.

1-2/F., Building 2, Jiaquan Building, Guanlan High-Tech Park, Shenzhen, Guangdong, China  
Tel: +86-755- 27521059 Fax: +86-755- 27521011 Http://www.sz-ctc.com.cn

## TEST REPORT

**Report No.** .....: **GTI20182113F**  
**FCC ID.** .....: **2AHVH58658646**  
**Applicant**.....: **Shen Zhen MTC Co.,LTD**  
**Address**.....: MTC Industry Park, 1st Lilang Road, Xialilang community, Nanwan street, Longgang district, Shenzhen, China  
**Manufacturer**.....: Shen Zhen MTC Co.,LTD  
**Address**.....: MTC Industry Park, 1st Lilang Road, Xialilang community, Nanwan street, Longgang district, Shenzhen, China  
**Product Name**.....: **LED TV**  
**Trade Mark**.....: AMTC,JVC  
**Model/Type reference**.....: MUAV5860Y-65864  
**Listed Model(s)** .....: MUAV58\*\*Y-65864( \* can from 0 to 9,A to Z); LT-58MAB887  
**Standard**.....: **47 CFR FCC Part 15 Subpart B - Unintentional Radiators  
ANSI C63.4: 2014**  
**Date of receipt of test sample**...: 2018-11-08  
**Date of testing**.....: 2018-11-08 to 2018-11-16  
**Date of issue**.....: 2018-11-16  
**Result**.....: **PASS**

Compiled by:  
(Printed name+signature) Torny Fang

Supervised by:  
( Printed name+signature) Cary Luo

Approved by:  
( Printed name+signature) Walter Chen

**Testing Laboratory Name**..... **Shenzhen General Testing & Inspection Technology Co.,Ltd.**  
**Address**..... 1-2/F., Building 2, Jiaquan Building, Guanlan High-Tech Park,  
Shenzhen, Guangdong, China

This test report may be duplicated completely for legal use with the approval of the applicant. It should not be reproduced except in full, without the written approval of our laboratory. The client should not use it to claim product endorsement by GTI. The test results in the report only apply to the tested sample. The test report shall be invalid without all the signatures of testing engineers, reviewer and approver. Any objections must be raised to GTI within 15 days since the date when the report is received. It will not be taken into consideration beyond this limit. The test report merely correspond to the test sample.

**Table of Contents****Page**

<b>1. TEST SUMMARY .....</b>	<b>3</b>
1.1. TEST STANDARDS.....	3
1.2. REPORT VERSION.....	3
1.3. TEST DESCRIPTION.....	4
1.4. TEST FACILITY .....	5
1.5. MEASUREMENT UNCERTAINTY .....	5
1.6. ENVIRONMENTAL CONDITIONS .....	6
<b>2. GENERAL INFORMATION .....</b>	<b>7</b>
2.1. CLIENT INFORMATION .....	7
2.2. GENERAL DESCRIPTION OF EUT .....	7
2.3. ACCESSORY EQUIPMENT INFORMATION .....	7
2.4. DESCRIPTION OF TEST MODES .....	8
2.5. MEASUREMENT INSTRUMENTS LIST .....	9
<b>3. EMC EMISSION TEST.....</b>	<b>10</b>
3.1. RADIATED EMISSION .....	10
3.2. CONDUCTED EMISSION (AC MAINS).....	16
3.3. ANTENNA POWER CONDUCTION MEASUREMENT .....	19
3.4. PICTURE SENSITIVITY MEASUREMENT.....	22
3.5. NOISE FIGURE MEASUREMENT .....	23
<b>4. EUT TEST PHOTOS .....</b>	<b>24</b>
<b>5. PHOTOGRAPHS OF EUT CONSTRUCTIONAL .....</b>	<b>25</b>

# 1. TEST SUMMARY

## 1.1. Test Standards

The tests were performed according to following standards:

[47 CFR FCC Part 15 Subpart B](#): Unintentional Radiators.

[ANSI C63.4: 2014](#): American National Standard for Methods of Measurement of Radio-Noise Emissions from Low-Voltage Electrical and Electronic Equipment in the Range of 9 kHz to 40GHz.

## 1.2. Report version

Revised No.	Date of issue	Description
01	2018-11-16	Original

### 1.3. Test Description

FCC CFR Title 47 FCC Part 15 Subpart B / ICES-003			
Test Item	Standard Section	Result	Test Engineer
	FCC Part 15 Subpart B		
Conducted Emissions Test	15.107	Pass	Will Chen
Radiated Emission Test	15.109	Pass	Will Chen
Antenna Power Conduction	15.111	Pass	Will Chen
Picture Sensitivity	15.117(f)	Pass	Will Chen
Noise figure	15.117(g)	Pass	Will Chen

Note: The measurement uncertainty is not included in the test result.

## 1.4. Test Facility

### Address of the report laboratory

**Shenzhen General Testing & Inspection Technology Co., Ltd.**

Add: 1-2/F., Building 2, Jiaquan Building, Guanlan High-Tech Park, Shenzhen, Guangdong, China

### Laboratory accreditation

The test facility is recognized, certified, or accredited by the following organizations:

#### **CNAS-Lab Code: L5365**

Shenzhen General Testing & Inspection Technology Co.,Ltd. has been assessed and proved to be in compliance with CNAS-CL01 Accreditation Criteria for Testing and Calibration Laboratories (identical to ISO/IEC 17025: 2005 General Requirements) for the Competence of Testing and Calibration Laboratories.

#### **A2LA-Lab Cert. No.: 4340.01**

Shenzhen General Testing & Inspection Technology Co.,Ltd. EMC Laboratory has been accredited by A2LA for technical competence in the field of electrical testing, and proved to be in compliance with ISO/IEC 17025: 2005 General Requirements for the Competence of Testing and Calibration Laboratories and any additional program requirements in the identified field of testing.

#### **IC Registration No.: 9783A**

The 3m alternate test site of Shenzhen General Testing & Inspection Technology Co.,Ltd.EMC Laboratory has been registered by Certification and Engineer Bureau of Industry Canada for the performance of with Registration NO.: 9783A on Jan, 2016.

#### **FCC-Registration No.: 951311**

Shenzhen General Testing & Inspection Technology Co.,Ltd. EMC Laboratory has been registered and fully described in a report filed with the (FCC) Federal Communications Commission. The acceptance letter from the FCC is maintained in our files. Registration 951311, Aug 26, 2017

## 1.5. Measurement Uncertainty

The data and results referenced in this document are true and accurate. The reader is cautioned that there may be errors within the calibration limits of the equipment and facilities. The measurement uncertainty was calculated for all measurements listed in this test report acc. to TR-100028-01 "Electromagnetic compatibility and Radio spectrum Matters (ERM);Uncertainties in the measurement of mobile radio equipment characteristics; Part 1" and TR-100028-02 "Electromagnetic compatibility and Radio spectrum Matters (ERM);Uncertainties in the measurement of mobile radio equipment characteristics; Part 2 " and is documented in the Shenzhen General Testing & Inspection Technology Co., Ltd. quality system acc. to DIN EN ISO/IEC 17025. Furthermore, component and process variability of devices similar to that tested may result in additional deviation. The manufacturer has the sole responsibility of continued compliance of the device.

Below is the best measurement capability for Shenzhen General Testing & Inspection Technology Co., Ltd.

Test Items	Measurement Uncertainty	Notes
Conducted Emissions 9kHz~30MHz	3.20 dB	(1)
Radiated Emissions 30~1000MHz	4.70 dB	(1)
Radiated Emissions 1~18GHz	5.00 dB	(1)
Radiated Emissions 18~40GHz	5.54 dB	(1)
Antenna Power Conduction Measurement	2.64 dB	(1)
Picture Sensitivity Measurement	1.85 dB	(1)
Noise Figure Measurement	2.30 dB	(1)

**Note:** (1) This uncertainty represents an expanded uncertainty expressed at approximately the 95% confidence level using a coverage factor of  $k=1.96$ .

## 1.6. Environmental conditions

During the measurement the environmental conditions were within the listed ranges:

Normal Temperature:	25°C
Relative Humidity	55 %
Air Pressure	989 hPa

## 2. GENERAL INFORMATION

### 2.1. Client Information

Applicant:	Shen Zhen MTC Co.,LTD
Address:	MTC Industry Park, 1st Lilang Road, Xialilang community, Nanwan street, Longgang district, Shenzhen, China
Manufacturer:	Shen Zhen MTC Co.,LTD
Address:	MTC Industry Park, 1st Lilang Road, Xialilang community, Nanwan street, Longgang district, Shenzhen, China

### 2.2. General Description of EUT

Product Name:	LED TV
Model/Type reference:	MUAV5860Y-65864
Marketing Name:	AMTC,JVC
Listed Model(s):	MUAV58**Y-65864( * can from 0 to 9,A to Z); LT-58MAB887
Model Difference:	the only differences are the appearance 、 trade name and model no.
Power supply:	INPUT: AC100-240V, 150W, 50/60Hz

### 2.3. Accessory Equipment information

Equipment Information			
Name	Model	S/N	Manufacturer
USB disk	DTGE9	---	Kingston
PC	p7-1035cn	---	HP
Keyboard	RFK-613	---	ERYEFU
Mouse	RFK-613	---	ERYEFU
Printer	HP LaserJet P1007	VNFN584036	HP
DVD Player	DV-310NC-K	---	Plioneer
Cable Information			
Name	Shielded Type	Ferrite Core	Length
VGA Cable	YES	YES	1.5M
HDMI Cable	YES	NO	1.2M
AV Cable	YES	YES	1.2M
component Cable	YES	YES	1.2M

## 2.4. Description of Test Modes

Test mode	ATSC	AV IN	HDMI IN	VGA IN	USB Playing	Lan	Component	NTSC
1	■							
2		■						
3			■					
4				■				
5					■			
6						■		
7							■	
8								■

Note:

1. ■ is operation mode.

Pre-scan above all test mode, found below test mode which it was worse case mode.

Test item	Test mode (Worse case mode)
Conducted emission	Mode 3
Radiated emission	Mode 4
Antenna Power Conduction	Mode 1
Picture Sensitivity	Mode 8
Noise figure	Mode 1



## 2.5. Measurement Instruments List

Conducted Emission					
Item	Test Equipment	Manufacturer	Model No.	Serial No.	Calibrated until
1	LISN	R&S	ENV216	101112	Jan. 04, 2019
2	LISN	R&S	ENV216	101113	Jan. 04, 2019
3	EMI Test Receiver	R&S	ESCI	100920	Jan. 04, 2019
4	UNIVERSAL RADIO COMMUNICATION	Rohde & Schwarz	CMU200	114694	Jan. 04, 2019
5	RF cable	Schwarzbeck	AK9515E	33154	Jan. 04, 2019

Radiated Emission					
Item	Test Equipment	Manufacturer	Model No.	Serial No.	Calibrated until
1	Log-Bicon Antenna	Schwarzbeck	CBL6141A	4180	Jan. 04, 2019
2	Spectrum Analyzer	HP	8563E	02052	Jan. 04, 2019
3	Horn Antenna	Schwarzbeck	BBHA 9120D	648	Jan. 04, 2019
4	Pre-Amplifier	HP	8447D	1937A03050	Jan. 04, 2019
5	Pre-Amplifier	EMCI	EMC051835	980075	Jan. 04, 2019
6	EMI Test Receiver	R&S	ESCI	100658	Jan. 04, 2019
7	Antenna Mast	UC	UC3000	N/A	N/A
8	Turn Table	UC	UC3000	N/A	N/A
9	UNIVERSAL RADIO COMMUNICATION	Rohde & Schwarz	CMU200	114694	Jan. 04, 2019
10	RF cable	Schwarzbeck	AK9515E	33155	Jan. 04, 2019

Antenna Power Conduction& Picture Sensitivity& Noise figure					
Item	Test Equipment	Manufacturer	Model No.	Serial No.	Calibrated until
1	EMI Test Receiver	R&S	ESCI	100920	Jan. 04, 2019
2	Spectrum Analyzer	R&S	FSU26	100105	Jan. 04, 2019
3	Digital signal generator	R&S	SFC-U	N/A	Jan. 04, 2019
4	Analog signal generator	PHILIPS	YQ-70C-1052 (PM5418)	N/A	Jan. 04, 2019
5	RF cable	Schwarzbeck	AK9515E	33154	Jan. 04, 2019

The Cal. Interval was one year.

### 3. EMC EMISSION TEST

#### 3.1. Radiated Emission

**LIMIT**

FCC CFR Title 47 Part 15 Subpart B Section 15.109

Frequency	Limit (dBuV/m @3m)	Value
30MHz-88MHz	40.00	Quasi-peak
88MHz-216MHz	43.50	Quasi-peak
216MHz-960MHz	46.00	Quasi-peak
960MHz-1GHz	54.00	Quasi-peak
Above 1GHz	54.00	Average
	74.00	Peak

**TEST CONFIGURATION**

(B) Radiated Emission Test Set-Up Frequency below 1 GHz

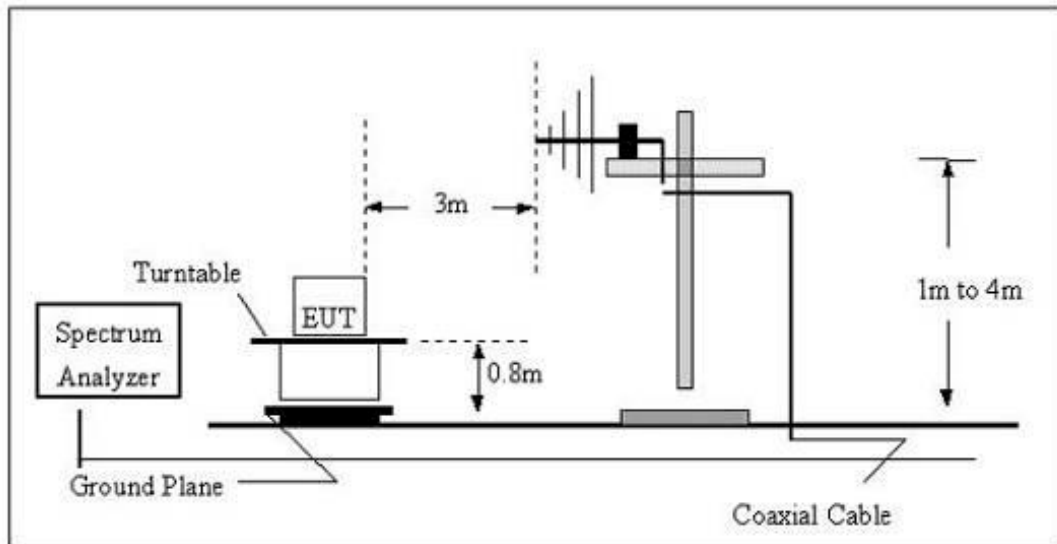

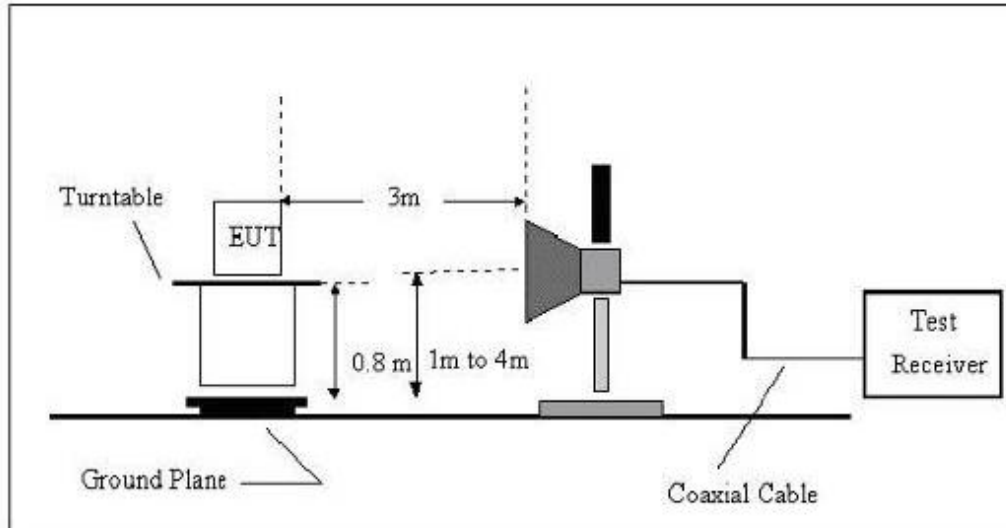
**(B) Radiated Emission Test Set-Up Frequency above 1GHz****TEST PROCEDURE**

1. The EUT was tested according to ANSI C63.4:2014.
2. The EUT is placed on a turn table which is 0.8 meter above ground. The turn table is rotated 360 degrees to determine the position of the maximum emission level.
3. The EUT was positioned such that the distance from antenna to the EUT was 3 meters.
4. The antenna is scanned from 1 meter to 4 meters to find out the maximum emission level. This is repeated for both horizontal and vertical polarization of the antenna.
5. Use the following spectrum analyzer settings
  - (1) Span shall be wide enough to fully capture the emission being measured;
  - (2) Below 1GHz, RBW=120KHz, VBW=300KHz, Sweep=auto, Detector function=peak, Trace=max hold;  
If the emission level of the EUT measured by the peak detector is 3 dB lower than the applicable limit, the peak emission level will be reported. Otherwise, the emission measurement will be repeated using the quasi-peak detector and reported.
  - (3) Above 1GHz, RBW=1MHz, VBW=3MHz

**TEST MODE:**

Please refer to the clause 2.3

**TEST RESULTS**

30MHz-1GHz

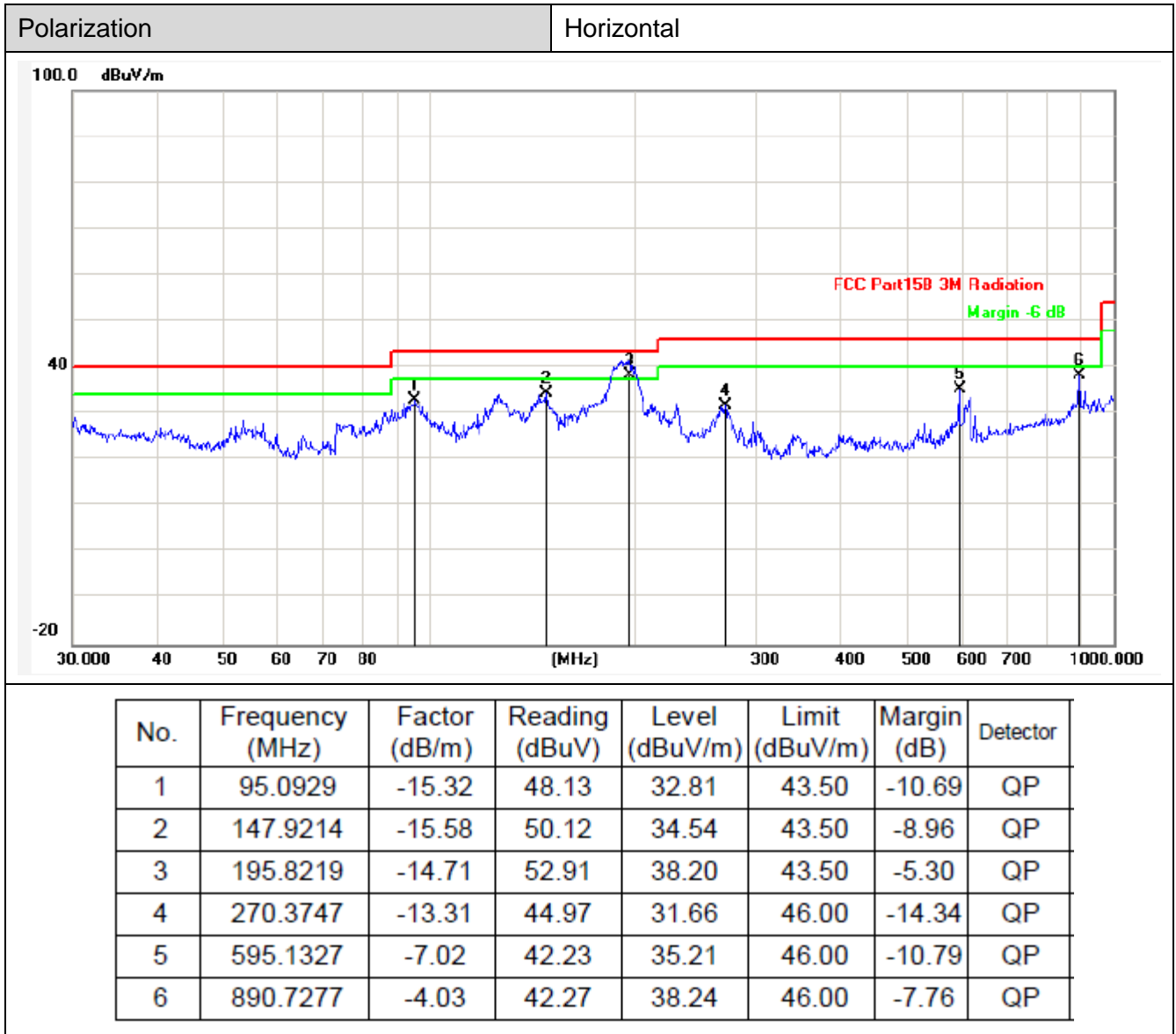

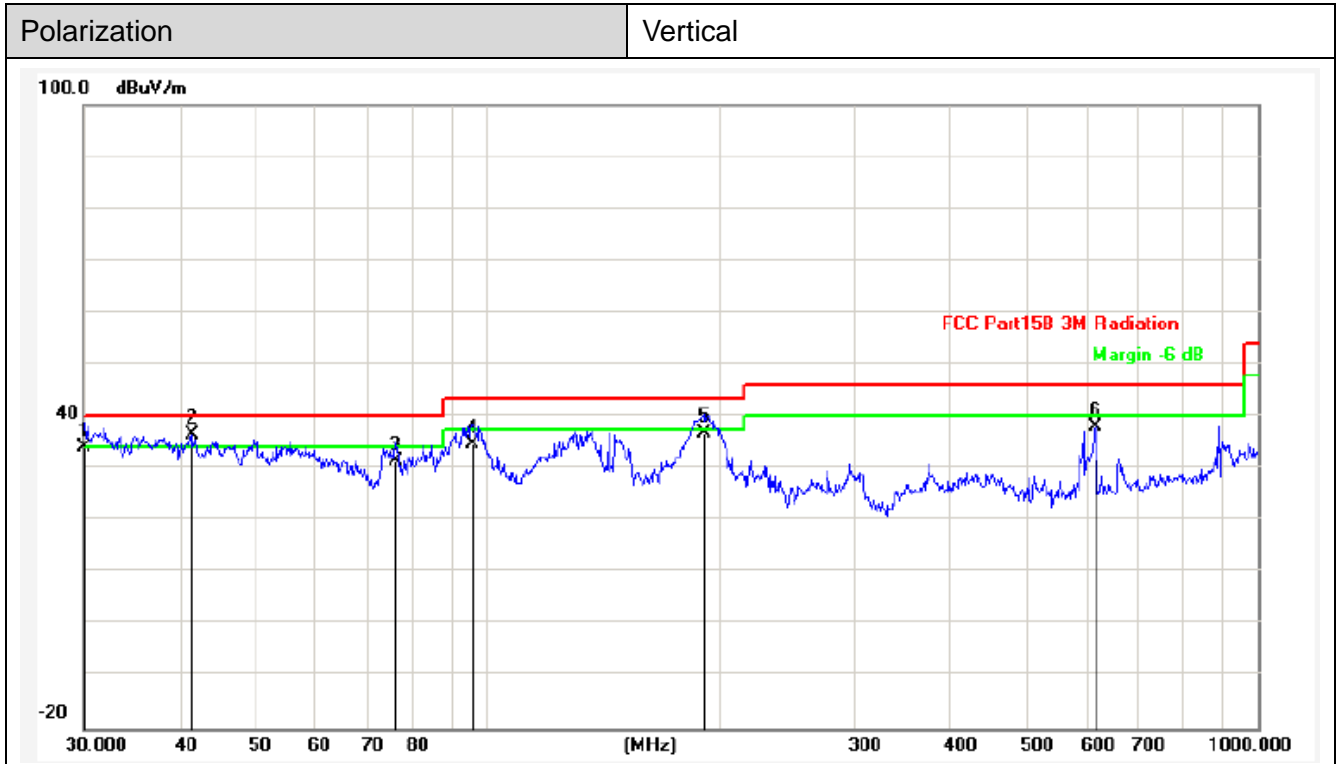

No.	Frequency (MHz)	Factor (dB/m)	Reading (dBuV)	Level (dBuV/m)	Limit (dBuV/m)	Margin (dB)	Detector
1	30.1053	-4.21	38.31	34.10	40.00	-5.90	QP
2	41.4215	-8.62	45.03	36.41	40.00	-3.59	QP
3	76.2442	-17.86	49.36	31.50	40.00	-8.50	QP
4	95.7622	-15.26	49.96	34.70	43.50	-8.80	QP
5	191.0738	-15.13	51.93	36.80	43.50	-6.70	QP
6	616.3716	-6.78	44.97	38.19	46.00	-7.81	QP

1GHz-6GHz

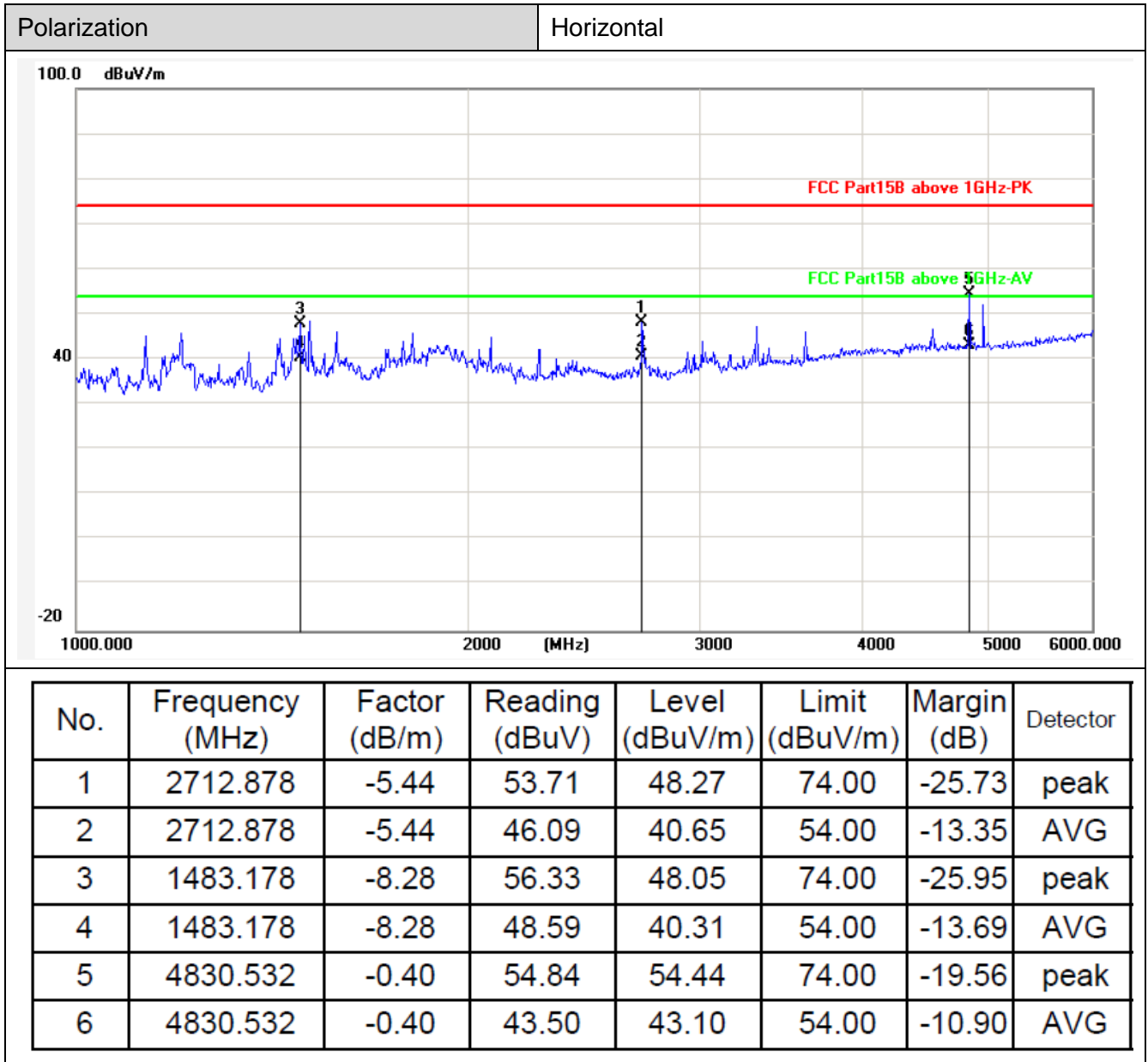

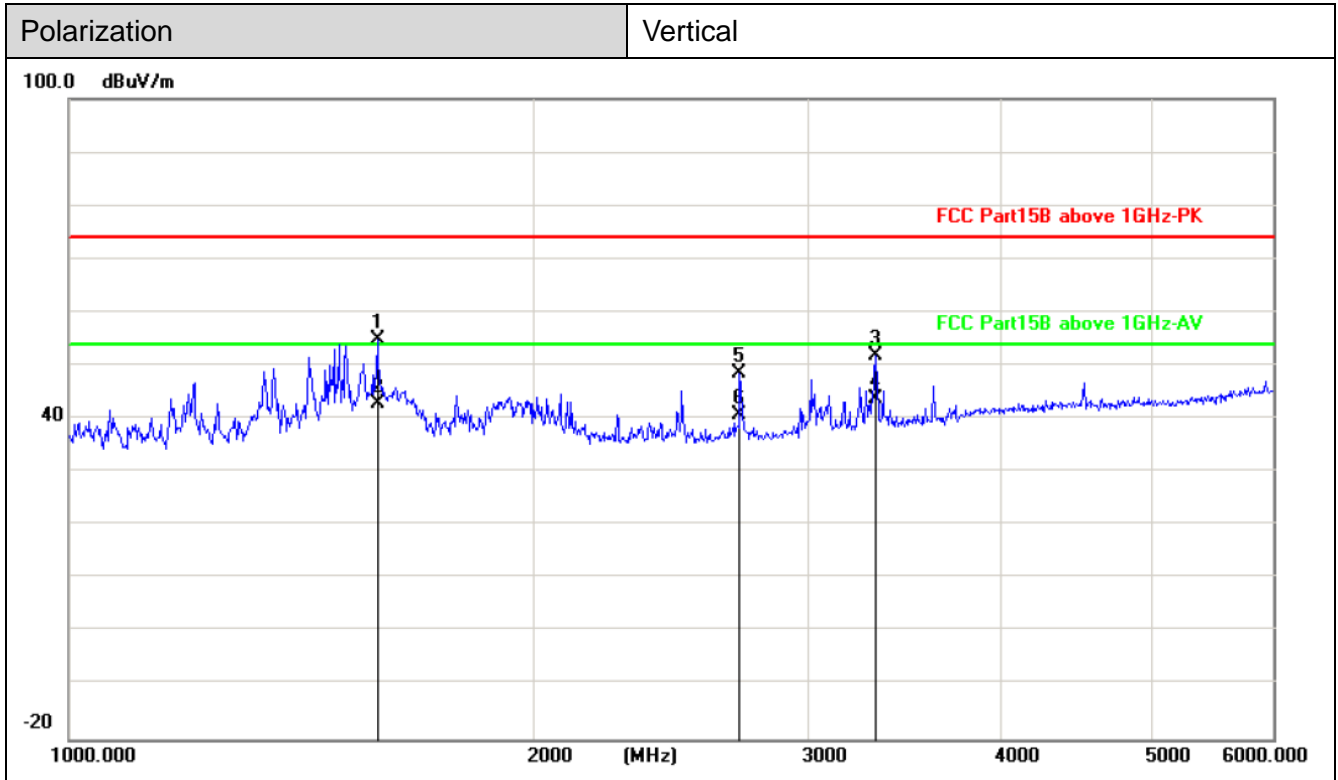

No.	Frequency (MHz)	Factor (dB/m)	Reading (dBUV)	Level (dBUV/m)	Limit (dBUV/m)	Margin (dB)	Detector
1	1582.001	-8.24	62.99	54.75	74.00	-19.25	peak
2	1582.001	-8.24	50.94	42.70	54.00	-11.30	AVG
3	3321.707	-4.54	56.25	51.71	74.00	-22.29	peak
4	3321.707	-4.54	48.24	43.70	54.00	-10.30	AVG
5	2712.878	-5.44	53.97	48.53	74.00	-25.47	peak
6	2712.878	-5.44	46.24	40.80	54.00	-13.20	AVG

REMARKS:

1. Emission level (dBUV/m) =Raw Value (dBUV)+Correction Factor (dB/m)
2. Correction Factor (dB/m) = Antenna Factor (dB/m)+Cable Factor (dB)-Pre-amplifier Factor
3. Margin value = Limit value- Emission level.
4. -- Mean the PK detector measured value is below average limit.
5. The other emission levels were very low against the limit.

### 3.2. Conducted Emission (AC Mains)

#### LIMIT

FCC CFR Title 47 Part 15 Subpart B Section 15.107

Frequency range (MHz)	Limit (dBuV)	
	Quasi-peak	Average
0.15-0.5	66 to 56*	56 to 46*
0.5-5	56	46
5-30	60	50

\* Decreases with the logarithm of the frequency.

#### TEST CONFIGURATION

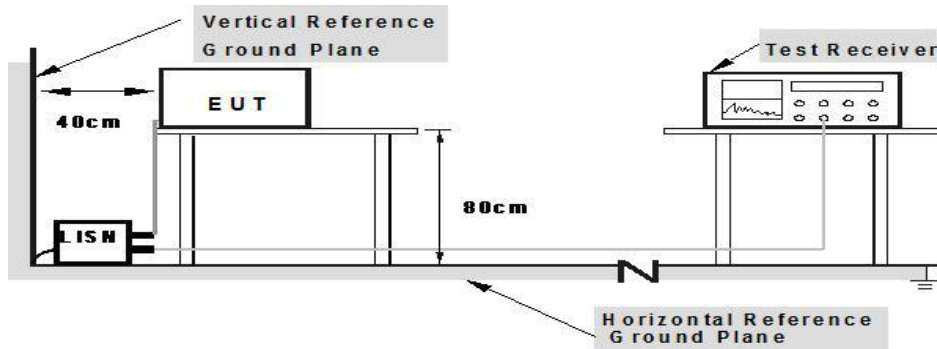

**Note: 1. Support units were connected to second LISN.  
2. Both of LISNs (AMN) are 80 cm from EUT and at least 80 cm from other units and other metal planes**

#### TEST PROCEDURE

1. The EUT was setup according to ANSI C63.4-2014.
2. The EUT was placed on a platform of nominal size, 1 m by 1.5 m, raised 80 cm above the conducting ground plane. The vertical conducting plane was located 40 cm to the rear of the EUT. All other surfaces of EUT were at least 80 cm from any other grounded conducting surface.
3. The EUT and simulators are connected to the main power through a line impedance stabilization network (LISN). The LISN provides a 50 ohm /50uH coupling impedance for the measuring equipment.
4. The peripheral devices are also connected to the main power through a LISN. (Please refer to the block diagram of the test setup and photographs)
5. Each current-carrying conductor of the EUT power cord, except the ground (safety) conductor, was individually connected through a LISN to the input power source.
6. The excess length of the power cord between the EUT and the LISN receptacle were folded back and forth at the center of the lead to form a bundle not exceeding 40 cm in length.
7. Conducted emissions were investigated over the frequency range from 0.15MHz to 30MHz using a receiver bandwidth of 9 kHz.
8. During the above scans, the emissions were maximized by cable manipulation.

#### TEST RESULTS

Shenzhen General Testing & Inspection Technology Co., Ltd.

1-2/F., Building 2, Jiaquan Building, Guanlan High-Tech Park, Shenzhen, Guangdong, China  
Tel.: (86)755-27521059 Fax: (86)755-27521011 Http://www.sz-ctc.org.cn



Polarization L

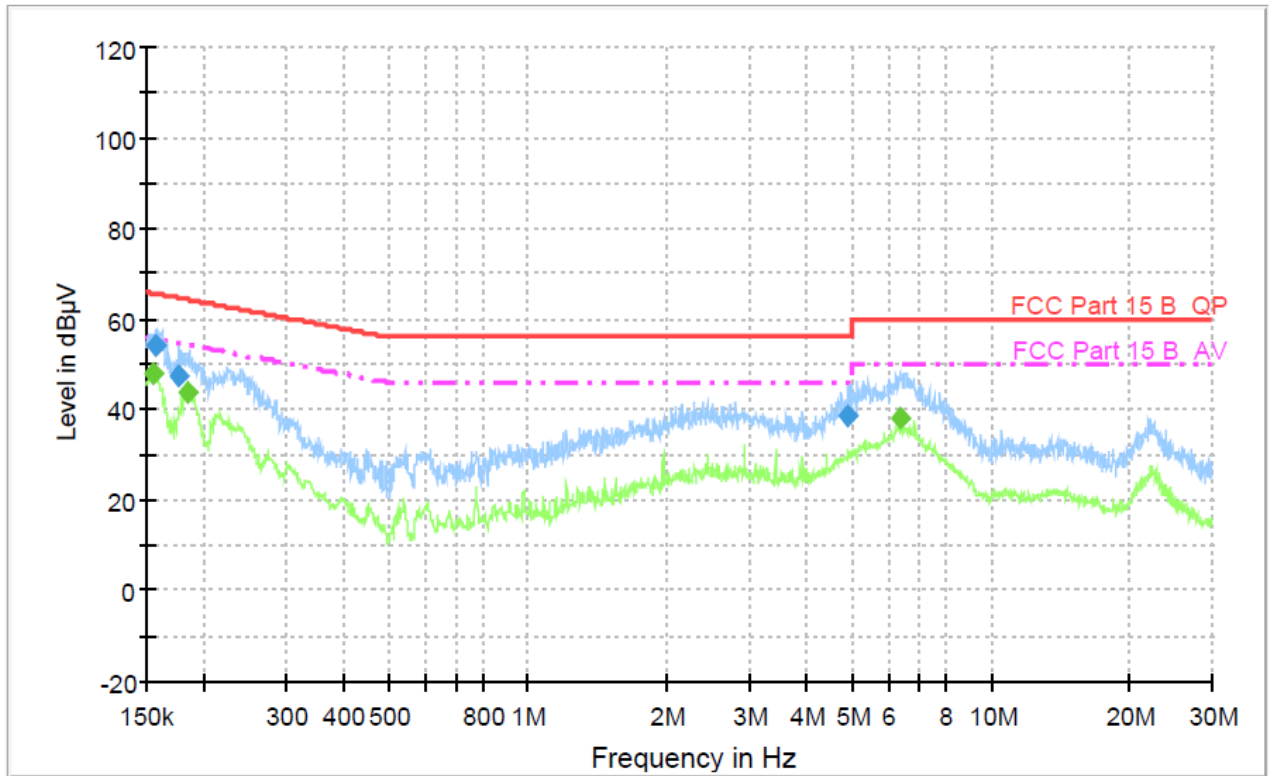

Frequency (MHz)	QuasiPeak (dBµV)	Meas. Time (ms)	Bandwidth (kHz)	Filter	Line	Corr. (dB)	Margin (dB)	Limit (dBµV)
0.157370	53.9	1000.000	9.000	Off	L1	10.0	11.7	65.6
0.176700	47.2	1000.000	9.000	Off	L1	10.0	17.4	64.6
4.891000	38.5	1000.000	9.000	Off	L1	10.0	17.5	56.0

Frequency (MHz)	Average (dBµV)	Meas. Time (ms)	Bandwidth (kHz)	Filter	Line	Corr. (dB)	Margin (dB)	Limit (dBµV)
0.155180	47.9	1000.000	9.000	Off	L1	10.0	7.8	55.7
0.185010	43.5	1000.000	9.000	Off	L1	10.0	10.8	54.3
6.367030	38.2	1000.000	9.000	Off	L1	10.1	11.8	50.0

Polarization N

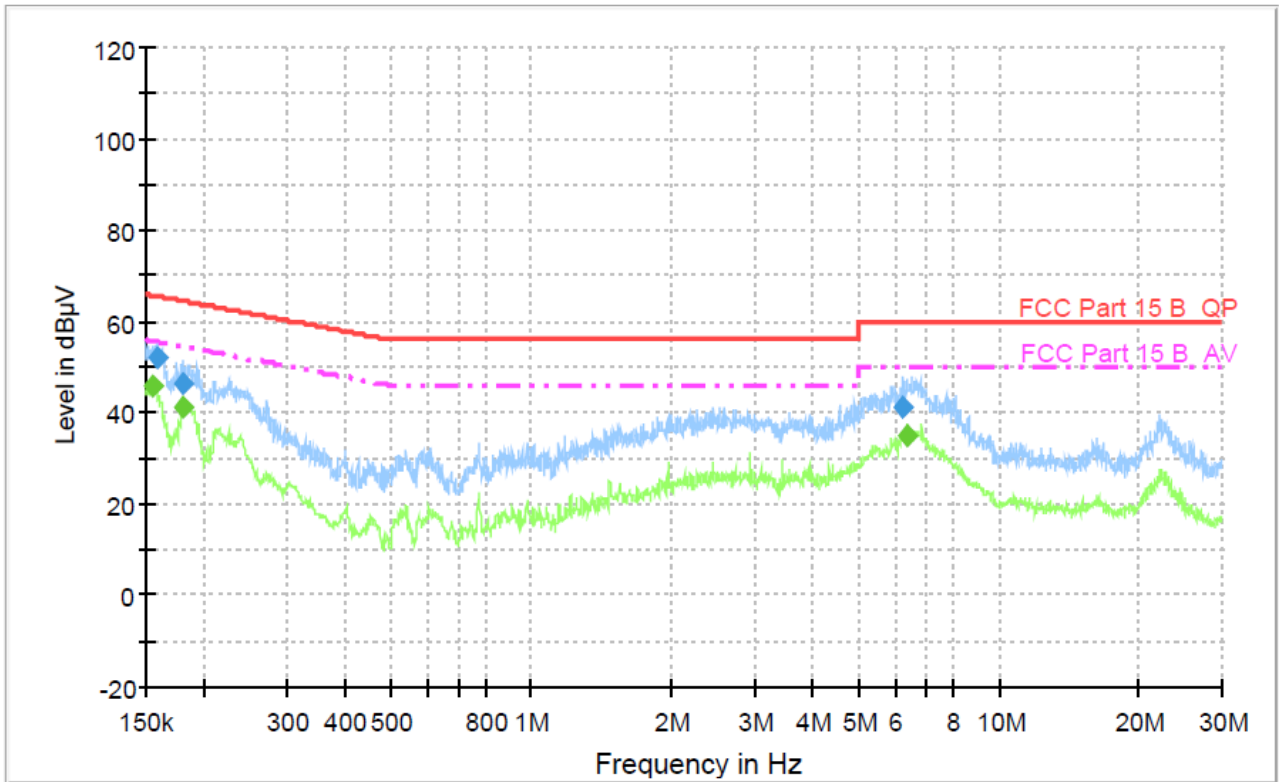

Frequency (MHz)	QuasiPeak (dBµV)	Meas. Time (ms)	Bandwidth (kHz)	Filter	Line	Corr. (dB)	Margin (dB)	Limit (dBµV)
0.158950	51.9	1000.000	9.000	Off	N	9.5	13.6	65.5
0.180270	46.4	1000.000	9.000	Off	N	9.5	18.1	64.5
6.253560	41.1	1000.000	9.000	Off	N	9.5	18.9	60.0

Frequency (MHz)	Average (dBµV)	Meas. Time (ms)	Bandwidth (kHz)	Filter	Line	Corr. (dB)	Margin (dB)	Limit (dBµV)
0.155800	45.9	1000.000	9.000	Off	N	9.5	9.8	55.7
0.180270	41.1	1000.000	9.000	Off	N	9.5	13.4	54.5
6.367030	34.8	1000.000	9.000	Off	N	9.5	15.2	50.0

### 3.3. Antenna Power Conduction Measurement

#### LIMITS

FCC Part 15, Subpart B, Clause 15.111

Limit(nW)	Limit (dB $\mu$ V)
2	51.7

#### TEST CONFIGURATION

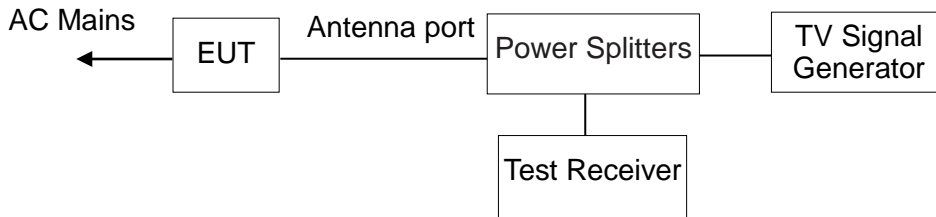

#### TEST PROCEDURE

1. The test item can be in deliver on shielding room.
2. The equipment was set up as per the test configuration to simulate typical actual usage per the user's manual. When the EUT is a tabletop system, a wooden table with a height of 0.8 meters is used and is placed on the ground plane as per ANSI C63.4 (see Test Facility for the dimensions of the ground plane used). When the EUT is a floor-standing equipment, it is placed on the ground plane which has a 3-12 mm non-conductive covering to insulate the EUT from the ground plane.
3. EUT receives AC power source from the outlet socket. All support equipment, if need, receives 120VAC/60Hz power from another socket.
4. With the 75~50 $\Omega$  matching network when the connected coaxial cable of impedance not matching.
5. The output level of the auxiliary signal generator shall be set to give the value of 70dB( $\mu$ V) for TV to the input of the frequency-modulation of television receiver respectively, on a 75 $\Omega$  impedance, An additional amplifier should be insert at the generator output, if necessary.
6. All I/O cables were positioned to simulate typical actual usage as per ANSI C63.4.
7. The results shall be expressed in the terms of the substitution power in nanowatt(nW), as supplied by the standard signal generator. The specified source impedance of the receiver shall be stated with the results.
8. When measurements are made at the antenna terminals of the equipment under test, an auxiliary signal generator shall be used to feed the equipment under test input with a standard test signal at the receiver tuning frequency.

Test results were obtained from the following equation:

$$\text{Emission Level (dB}\mu\text{V)} = \text{Power splitter Factor (dB)} + \text{Cable Loss (dB)} + \text{Reading (dB}\mu\text{V)}$$

$$\text{Margin (dB)} = \text{Emission Level (dB}\mu\text{V)} - \text{Limit (dB}\mu\text{V)}$$

**TEST RESULTS**

Channel	Frequency (MHz)	Measured Frequency (MHz)	Reading (dBμV)	Limit (dBμV)	Margin (dB)
2	101.000	101.000	<30.0	50.0	<20.0
	202.000	202.000	<30.0	50.0	<20.0
3	107.000	107.000	<30.0	50.0	<20.0
	214.000	214.000	<30.0	50.0	<20.0
4	113.000	113.000	<30.0	50.0	<20.0
	226.000	226.000	<30.0	50.0	<20.0
5	123.000	123.000	<30.0	50.0	<20.0
	246.000	246.000	<30.0	50.0	<20.0
6	129.000	129.000	<30.0	50.0	<20.0
	258.000	258.000	<30.0	50.0	<20.0
7	221.000	221.000	<30.0	50.0	<20.0
	442.000	442.000	<30.0	50.0	<20.0
8	227.000	227.000	<30.0	50.0	<20.0
	454.000	454.000	<30.0	50.0	<20.0
9	233.000	233.000	<30.0	50.0	<20.0
	466.000	466.000	<30.0	50.0	<20.0
10	239.000	239.000	<30.0	50.0	<20.0
	478.000	478.000	<30.0	50.0	<20.0
11	245.000	245.000	<30.0	50.0	<20.0
	490.000	490.000	<30.0	50.0	<20.0
12	251.000	251.000	<30.0	50.0	<20.0
	502.000	502.000	<30.0	50.0	<20.0

Note: Negative signs (-) in the margin column signify levels below the limit.  
 Limit (50dBμV) was converted from the limit (2nW) at the 50Ω measurement impedance.

Channel	Frequency (MHz)	Measured Frequency (MHz)	Reading (dB $\mu$ V)	Limit (dB $\mu$ V)	Margin (dB)
13	257.000	257.000	<30.0	50.0	<20.0
	514.000	514.000	<30.0	50.0	<20.0
14	517.000	517.000	<30.0	50.0	<20.0
	1034.000	1034.000	<30.0	50.0	<20.0
15	523.000	523.000	<30.0	50.0	<20.0
	1046.000	1046.000	<30.0	50.0	<20.0
20	553.000	553.000	<30.0	50.0	<20.0
	1106.000	1106.000	<30.0	50.0	<20.0
28	601.000	601.000	<30.0	50.0	<20.0
	1202.000	1202.000	<30.0	50.0	<20.0
36	649.000	649.000	<30.0	50.0	<20.0
	1298.000	1298.000	<30.0	50.0	<20.0
45	703.000	703.000	<30.0	50.0	<20.0
	1406.000	1406.000	<30.0	50.0	<20.0
53	751.000	751.000	<30.0	50.0	<20.0
	1502.000	1502.000	<30.0	50.0	<20.0
61	799.000	799.000	<30.0	50.0	<20.0
	1598.000	1598.000	<30.0	50.0	<20.0
69	847.000	847.000	<30.0	50.0	<20.0
	1694.000	1694.000	<30.0	50.0	<20.0

Note: Negative signs (-) in the margin column signify levels below the limit.

Limit (50dB $\mu$ V) was converted from the limit (2nW) at the 50 $\Omega$  measurement impedance.

### 3.4. Picture Sensitivity Measurement

#### TEST RESULTS

VHF Band		Antenna Input Level (dBμV)	UHF Band		Antenna Input Level (dBμV)
Channel	Frequency Range (MHz)		Channel	Frequency Range (MHz)	
2	55.250	26	14	471.250	27
3	61.250	25	20	507.250	27
4	67.250	25	26	543.250	29
5	77.250	23	32	579.250	24
6	83.250	26	38	615.250	29
7	175.250	28	44	651.250	25
8	181.250	26	50	687.250	24
9	187.250	27	56	723.250	23
10	193.250	29	62	759.250	26
11	199.250	26	69	801.250	25
12	205.250	24	/	/	/
13	211.250	24	/	/	/
Average(VHF)		25.75	Average(UHF)		25.9
Average(UHF)-Average(VHF)=0.15 dB(Limit 8.0dB)					

### 3.5. Noise Figure Measurement

#### TEST RESULTS

Channel	Frequency (MHz)	Measured Frequency (MHz)	Gain (dB)	Noise Figure (dB)	Limit (dB)
2	101.000	101.000	>30.0	3.5	14
3	107.000	107.000	>30.0	3.6	14
4	113.000	113.000	>30.0	3.7	14
5	123.000	123.000	>30.0	3.8	14
6	129.000	129.000	>30.0	3.4	14
7	221.000	221.000	>30.0	3.3	14
8	227.000	227.000	>30.0	3.8	14
9	233.000	233.000	>30.0	3.6	14
10	239.000	239.000	>30.0	3.5	14
11	245.000	245.000	>30.0	3.8	14
12	251.000	251.000	>30.0	3.6	14
13	257.000	257.000	<30.0	3.6	14
14	517.000	517.000	<30.0	3.6	14
15	523.000	523.000	<30.0	3.8	14
20	553.000	553.000	<30.0	3.5	14
28	601.000	601.000	<30.0	3.8	14
36	649.000	649.000	<30.0	3.4	14
45	703.000	703.000	<30.0	3.5	14
53	751.000	751.000	<30.0	3.8	14
61	799.000	799.000	<30.0	3.6	14
69	847.000	847.000	<30.0	3.4	14

Remark: The specification was provided by tuner manufacturer.

## 4. EUT TEST PHOTOS

Reference to the document No.: Test Photographs



## 5. PHOTOGRAPHS OF EUT CONSTRUCTIONAL

Reference to the document No.: External Photographs and Internal Photographs.

\*\*\*\*\*THE END\*\*\*\*\*