



# Shenzhen General Testing & Inspection Technology Co., Ltd.

1-2/F., Building 2, Jiaquan Building, Guanlan High-Tech Park, Shenzhen, Guangdong, China  
Tel : +86-755-27521059  
Fax: +86-755-27521011

## FCC TEST REPORT

**Product name**..... : LED TV

**Trademark**..... : AMTC,JVC

**Model Name**..... : MUAV5061Y-65864

**Adding Model**..... : MUAV50\*\*Y-65864( \* can from 0 to 9,A to Z),  
LT-50MA877 ,LT-50MA887

**Test Standards** ..... : **FCC CFR Title 47 Part 15 Subpart B**

**FCC ID**..... : 2AHVH5065864

**Report no.** ..... : GTI20180905E

**Applicant** ..... : Shen Zhen MTC Co.,LTD

**Address of applicant** ..... : MTC Industry Park, 1st Lilang Road, Xialilang community, Nanwan street,Longgang district, Shenzhen, China

**Date of Receipt**..... : May 10, 2018

**Date of Test Date**..... : May 10, 2018 to May 22, 2018

**Date of issue.** ..... : May 22, 2018

<b>Test result</b> ..... :	Pass *
----------------------------	--------

\* In the configuration tested, the EUT complied with the standards specified above



The FCC mark as shown above can be used, under the responsibility of the manufacturer, all necessary steps have been enforced to assure that all production units of the same equipment will continue to comply with the Federal Communications Commission's requirements.

Shenzhen General Testing & Inspection Technology Co., Ltd.

1-2/F., Building 2, Jiaquan Building, Guanlan High-Tech Park, Shenzhen, Guangdong, China

Tel.: (86)755-27521059

Fax.: (86)755-27521011

Http://www.sz-ctc.org.cn



For anti-fake verification, please visit the official website of Certification and Accreditation Administration of the People's Republic of China : [yz.cncaic.cn](http://yz.cncaic.cn)

**GENERAL DESCRIPTION OF EUT**

Equipment	LED TV
Model Name	MUAV5061Y-65864
Adding Model	MUAV50**Y-65864( * can from 0 to 9,A to Z), LT-50MA877 ,LT-50MA887
Model Difference	Just different colors and trademarks, the other is the same
Manufacturer	Shen Zhen MTC Co.,LTD
Manufacturer Address	MTC Industry Park, 1st Lilang Road, Xialilang community, Nanwan street,Longgang district, Shenzhen, China
Factory	Shen Zhen MTC Co.,LTD
Factory Address	MTC Industry Park, 1st Lilang Road, Xialilang community, Nanwan street,Longgang district, Shenzhen, China
Product Description	Based on the application, features, or specification exhibited in User's Manual, the EUT is considered as as both an ITE /Computing Device & a Sound and Television Broadcast Receiver. More details of EUT technical specification, please refer to the User's Manual.
Power Rating	Input: AC100-240V, 120W, 50/60Hz
Operational frequency	The EUT max operation frequency is 1.2GHz

Compiled By:

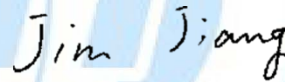

(Jim Jiang)

Reviewed By:



(Gavin Shi)

Approved By:

(Walter Chen)

This test report may be duplicated completely for legal use with the approval of the applicant. It should not be reproduced except in full, without the written approval of our laboratory. The client should not use it to claim product endorsement by GTI. The test results in the report only apply to the tested sample. The test report shall be invalid without all the signatures of testing engineers, reviewer and approver. Any objections must be raised to GTI within 15 days since the date when the report is received. It will not be taken into consideration beyond this limit.

Table of Contents	Page
<b>1 TEST SUMMARY.....</b>	<b>4</b>
TEST PROCEDURES ACCORDING TO THE TECHNICAL STANDARDS: .....	4
EMC EMISSION .....	4
1.1 TEST FACILITY .....	4
<b>2 GENERAL INFORMATION .....</b>	<b>5</b>
2.1 DESCRIPTION OF TEST MODES .....	5
2.2 DESCRIPTION TEST PERIPHERAL AND EUT PERIPHERAL .....	6
2.3 MEASUREMENT INSTRUMENTS EQUIPMENTS LIST .....	7
<b>3 CONDUCTED EMISSION MEASUREMENT .....</b>	<b>8</b>
3.1 LIMITS OF CONDUCTED EMISSION .....	8
3.2 TEST PROCEDURE.....	9
3.3 TEST SETUP .....	9
3.4 EUT OPERATING CONDITIONS .....	9
3.5 TEST RESULTS .....	10
<b>4 RADIATED EMISSION MEASUREMENT .....</b>	<b>22</b>
4.1 LIMITS OF RADIATED EMISSION MEASUREMENT.....	22
4.2 TEST PROCEDURE.....	22
4.3 TEST SETUP .....	23
4.4 EUT OPERATING CONDITIONS .....	23
4.5 TEST RESULTS .....	24
<b>5 EUT TEST PHOTO .....</b>	<b>36</b>
<b>6 ATTACHMENT PHOTOGRAPHS OF EUT .....</b>	<b>38</b>

# 1 TEST SUMMARY

Test procedures according to the technical standards:

EMC Emission				
Standard	Test Item	Limit	Result	Remark
FCC CFR Title 47 Part 15 Subpart B ANSI C63.4: 2014	FCC Part 15 Section 15.107	Class B	PASS	---
	FCC Part 15 Section 15.109	Class B	PASS	---

## 1.1 TEST FACILITY

Shenzhen General Testing & Inspection Technology Co., Ltd.

Add. : 1-2F., Building 2, Jiaquan Building, Guanlan High-Tech Park, Shenzhen, Guangdong, China

### IC Registration No.: 9783A

The 3m alternate test site of Shenzhen GTI Technology Co., Ltd. EMC Laboratory has been registered by Certification and Engineer Bureau of Industry Canada for the performance of with Registration NO.: 9783A on Jan, 2016.

### FCC-Registration No.: 951311

Shenzhen GTI Technology Co., Ltd. EMC Laboratory has been registered and fully described in a report filed with the (FCC) Federal Communications Commission. The acceptance letter from the FCC is maintained in our files. Registration 951311, Aug 26, 2017

### MEASUREMENT UNCERTAINTY

The reported uncertainty of measurement  $y \pm U$ , where expanded uncertainty  $U$  is based on a standard uncertainty multiplied by a coverage factor of  $k=2$ , providing a level of confidence of approximately 95 %.

#### A. Conducted Measurement :

Test Site	Method	Measurement Frequency Range	U , (dB)	NOTE
GTIC01	ANSI	150 KHz ~ 30MHz	3.2	

#### B. Radiated Measurement :

Test Site	Method	Measurement Frequency Range	U , (dB)	NOTE
GTIA01	ANSI	30MHz ~ 1000MHz	4.7	
		1GHz ~6GHz	5.0	

## 2 GENERAL INFORMATION

### 2.1 DESCRIPTION OF TEST MODES

As the function of the EUT, test mode selected to test as below to conform this standard.

test Mode	Description
Mode 1	AV IN
Mode 2	HDMI1
Mode 3	HDMI2
Mode 4	HDMI3
Mode 5	USB1
Mode 6	USB2

Note:

Pre-scan above all test mode and voltage(120Vac/60Hz and 230Vac/50Hz), found below test mode and voltage which it was worse case mode.

Test item	Worse case operation Test mode	Worse case operation Test Voltage
Conducted emission	Mode 1/ Mode 2/ Mode 3/ Mode 4/ Mode 5/ Mode 6	120V/60Hz
Radiated emission	Mode 1/ Mode 2/ Mode 3/ Mode 4/ Mode 5/ Mode 6	120V/60Hz



## 2.2 DESCRIPTION TEST PERIPHERAL AND EUT PERIPHERAL

The EUT has been tested as an independent unit together with other necessary accessories or support units. The following support units or accessories were used to form a representative test configuration during the tests.

Item	Equipment	Mfr/Brand	Model/Type No.	Series No.	Note
E-1	LED TV	AMTC,JVC	MUAV5061Y-658 64	N/A	EUT
E-2	PC	HP	P7-1035cn	4CV125C15J	AE
E-3	DVD	GIEC	GK-901	N/A	AE
E-4	TV Generator	DTV tool	DTV	N/A	AE
E-5	Printer	HP	P1007	VNFN584036	AE
E-6	USB Disk	Kingston	DT101G2/8GB	253394	AE

Item	Shielded Type	Ferrite Core	Length	Note
C-1	NO	NO	120cm	AC Line
C-2	NO	NO	150cm	AV Line
C-3	YES	YES	150cm	HDMI Line
C-4	YES	YES	150cm	TV Line

Note:

- (1) The support equipment was authorized by Declaration of Confirmation.
- (2) For detachable type I/O cable should be specified the length in cm in 『Length』 column.
- (3) “YES” is means “shielded” “with core”; “NO” is means “unshielded” “without core”.

**2.3 MEASUREMENT INSTRUMENTS EQUIPMENTS LIST**

Conducted Emission					
Item	Test Equipment	Manufacturer	Model No.	Serial No.	Calibrated until
1	LISN	R&S	ENV216	101112	Jan. 04, 2019
2	LISN	R&S	ENV216	101113	Jan. 04, 2019
3	EMI Test Receiver	R&S	ESCI	100920	Jan. 04, 2019
4	ISN CAT6	Schwarzbeck	NTFM 8158	8158-0046	Jan. 04, 2019

Radiated Emission					
Item	Test Equipment	Manufacturer	Model No.	Serial No.	Calibrated until
1	Bilog Antenna	Schwarzbeck	CBL6141A	4180	Jan. 04, 2019
2	Spectrum Analyzer	R&S	FSU26	100105	Jan. 04, 2019
3	Horn Antenna	Schwarzbeck	BBHA 9120D	647	Jan. 04, 2019
4	Low Noise Pre-Amplifier	HP	8447D	1937A03050	Jan. 04, 2019
5	Low Noise Pre-Amplifier	EMCI	EMC051835	980075	Jan. 04, 2019
6	Test Receiver	R&S	ESCI7	100967	Jan. 04, 2019
7	Antenna Mast	UC	UC3000	N/A	N/A
8	Turn Table	UC	UC3000	N/A	N/A



### 3 CONDUCTED EMISSION MEASUREMENT

#### 3.1 Limits of Conducted Emission

FREQUENCY (MHz)	Class A (dBuV)		Class B (dBuV)	
	Quasi-peak	Average	Quasi-peak	Average
0.15 -0.5	79.00	66.00	66 - 56 *	56 - 46 *
0.50 -5.0	73.00	60.00	56.00	46.00
5.0 -30.0	73.00	60.00	60.00	50.00

Note:

- (1) The tighter limit applies at the band edges.
- (2) The limit of " \* " marked band means the limitation decreases linearly with the logarithm of the frequency in the range.

The following table is the setting of the receiver

Receiver Parameters	Setting
Attenuation	10 dB
Start Frequency	0.15 MHz
Stop Frequency	30 MHz
IF Bandwidth	9 kHz



### 3.2 TEST PROCEDURE

- The EUT was placed 0.8 meters from the horizontal ground plane with EUT being connected to the power mains through a line impedance stabilization network (LISN). All other support equipments powered from additional LISN(s). The LISN provide 50 Ohm/ 50uH of coupling impedance for the measuring instrument.
- Interconnecting cables that hang closer than 40 cm to the ground plane shall be folded back and forth in the center forming a bundle 30 to 40 cm long.
- I/O cables that are not connected to a peripheral shall be bundled in the center. The end of the cable may be terminated, if required, using the correct terminating impedance. The overall length shall not exceed 1 m.
- LISN at least 80 cm from nearest part of EUT chassis.
- For the actual test configuration, please refer to the related Item –EUT Test Photos.

### 3.3 TEST SETUP

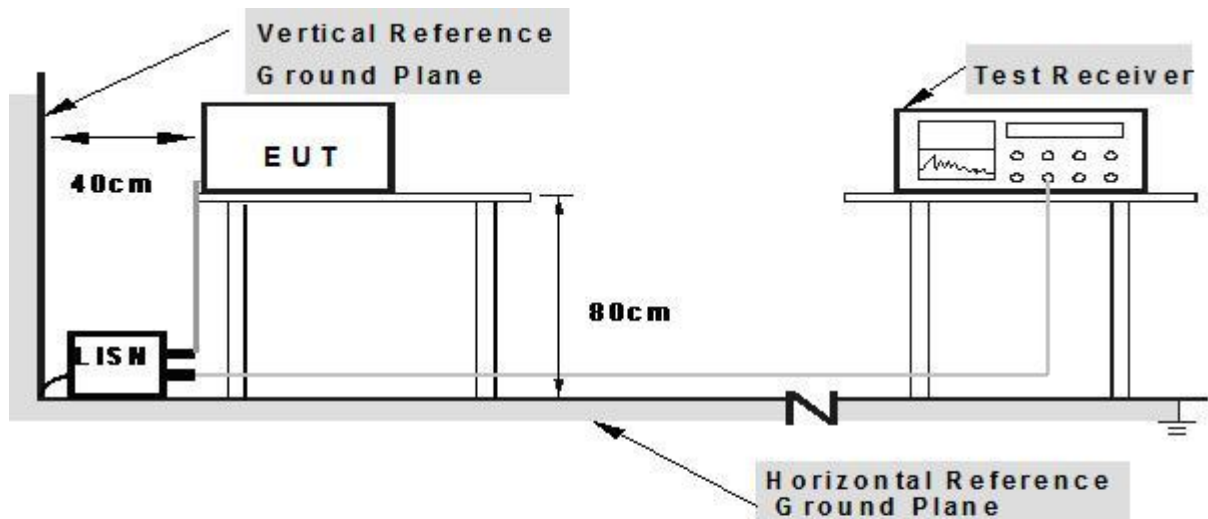

**Note: 1.Support units were connected to second LISN.**

**2.Both of LISN s (AMN) are 80 cm from EUT and at least 80 from other units and other metal planes**

### 3.4 EUT OPERATING CONDITIONS

The EUT tested system was configured as the statements of 2.1 Unless otherwise a special operating condition is specified in the follows during the testing.

### 3.5 TEST RESULTS

Temperature :	23.5°C	Relative Humidity :	56%
Pressure :	101 Kpa	Test Mode :	Mode 1
Test Voltage:	AC 120V/60Hz	Phase :	L

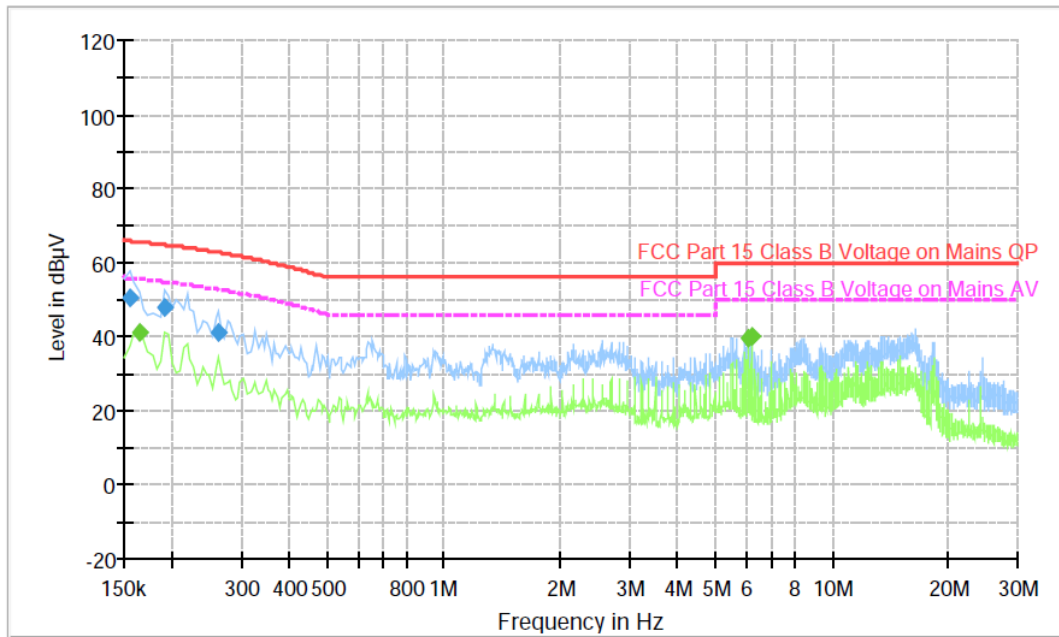

#### Final Measurement Detector 1

Frequency (MHz)	QuasiPeak (dBµV)	Meas. Time (ms)	Bandwidth (kHz)	Filter	Line	Corr. (dB)	Margin (dB)	Limit (dBµV)	Comment
0.154500	50.8	1000.000	9.000	Off	L1	10.0	15.1	65.9	
0.190500	47.7	1000.000	9.000	Off	L1	10.0	17.1	64.8	
0.262500	41.4	1000.000	9.000	Off	L1	9.9	21.4	62.8	

#### Final Measurement Detector 2

Frequency (MHz)	Average (dBµV)	Meas. Time (ms)	Bandwidth (kHz)	Filter	Line	Corr. (dB)	Margin (dB)	Limit (dBµV)	Comment
0.163500	41.3	1000.000	9.000	Off	L1	10.0	14.3	55.6	
6.063000	39.8	1000.000	9.000	Off	L1	9.7	10.2	50.0	
6.198000	40.1	1000.000	9.000	Off	L1	9.7	9.9	50.0	

Temperature :	23.5°C	Relative Humidity :	56%
Pressure :	101 Kpa	Test Mode :	Mode 1
Test Voltage:	AC 120V/60Hz	Phase :	N

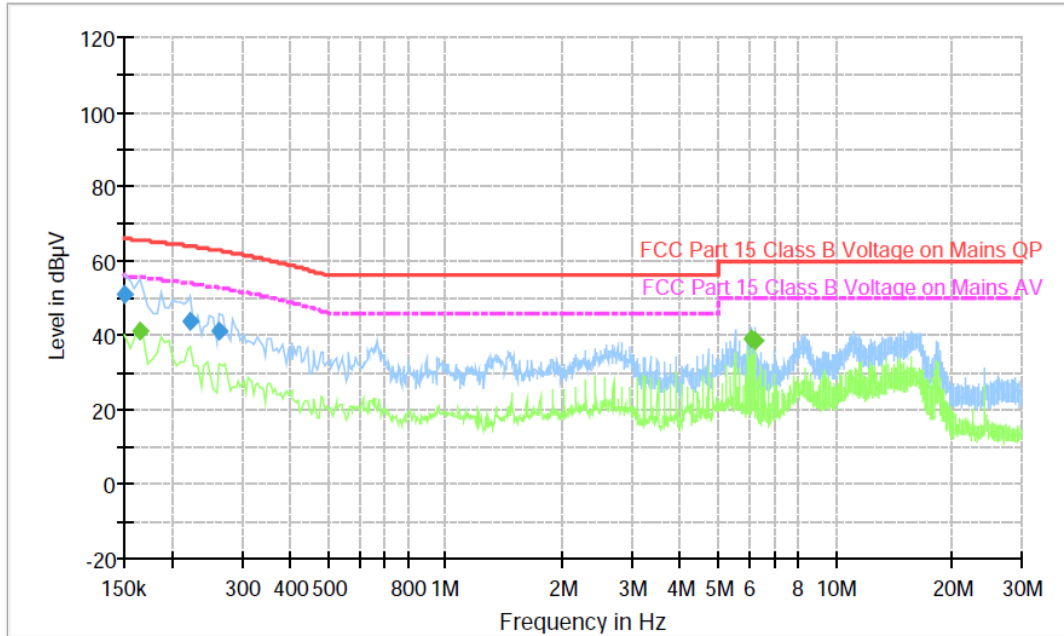

### Final Measurement Detector 1

Frequency (MHz)	QuasiPeak (dBµV)	Meas. Time (ms)	Bandwidth (kHz)	Filter	Line	Corr. (dB)	Margin (dB)	Limit (dBµV)	Comment
0.150000	51.2	1000.000	9.000	Off	N	9.6	14.8	66.0	
0.222000	44.0	1000.000	9.000	Off	N	9.6	19.9	63.9	
0.262500	41.1	1000.000	9.000	Off	N	9.7	21.7	62.8	

### Final Measurement Detector 2

Frequency (MHz)	Average (dBµV)	Meas. Time (ms)	Bandwidth (kHz)	Filter	Line	Corr. (dB)	Margin (dB)	Limit (dBµV)	Comment
0.163500	40.9	1000.000	9.000	Off	N	9.6	14.7	55.6	
6.067500	39.2	1000.000	9.000	Off	N	9.8	10.8	50.0	
6.202500	38.7	1000.000	9.000	Off	N	9.8	11.3	50.0	



Temperature :	23.5°C	Relative Humidity :	56%
Pressure :	101 Kpa	Test Mode :	Mode 2
Test Voltage:	AC 120V/60Hz	Phase :	L

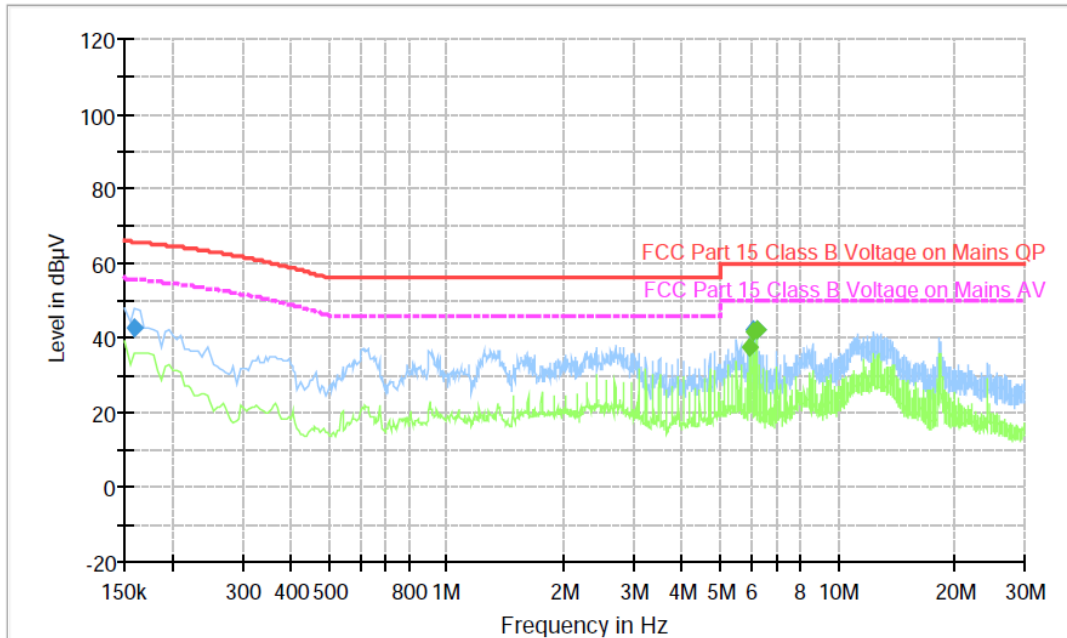

### Final Measurement Detector 1

Frequency (MHz)	QuasiPeak (dBµV)	Meas. Time (ms)	Bandwidth (kHz)	Filter	Line	Corr. (dB)	Margin (dB)	Limit (dBµV)	Comment
0.159000	43.0	1000.000	9.000	Off	L1	10.0	22.7	65.7	
6.058500	42.2	1000.000	9.000	Off	L1	9.7	17.8	60.0	
6.193500	42.4	1000.000	9.000	Off	L1	9.7	17.6	60.0	

### Final Measurement Detector 2

Frequency (MHz)	Average (dBµV)	Meas. Time (ms)	Bandwidth (kHz)	Filter	Line	Corr. (dB)	Margin (dB)	Limit (dBµV)	Comment
5.923500	37.4	1000.000	9.000	Off	L1	9.8	12.6	50.0	
6.058500	41.9	1000.000	9.000	Off	L1	9.7	8.1	50.0	
6.193500	42.1	1000.000	9.000	Off	L1	9.7	7.9	50.0	

Shenzhen General Testing & Inspection Technology Co., Ltd.

1-2/F., Building 2, Jiaquan Building, Guanlan High-Tech Park, Shenzhen, Guangdong, China

Tel.: (86)755-27521059

Fax.: (86)755-27521011 Http://www.sz-ctc.org.cn



For anti-fake verification, please visit the official website of Certification and Accreditation Administration of the People's Republic of China : [yz.cncaic.cn](http://yz.cncaic.cn)

Temperature :	23.5°C	Relative Humidity :	56%
Pressure :	101 Kpa	Test Mode :	Mode 2
Test Voltage:	AC 120V/60Hz	Phase :	N

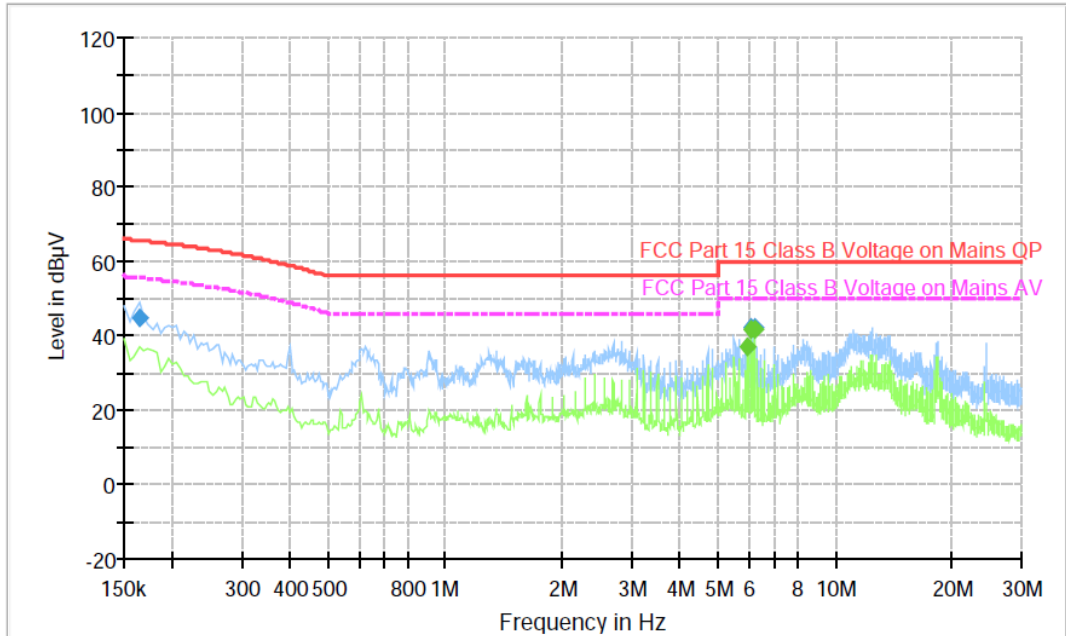

### Final Measurement Detector 1

Frequency (MHz)	QuasiPeak (dBµV)	Meas. Time (ms)	Bandwidth (kHz)	Filter	Line	Corr. (dB)	Margin (dB)	Limit (dBµV)	Comment
0.163500	44.7	1000.000	9.000	Off	N	9.6	20.9	65.6	
6.058500	42.0	1000.000	9.000	Off	N	9.8	18.0	60.0	
6.193500	42.1	1000.000	9.000	Off	N	9.8	17.9	60.0	

### Final Measurement Detector 2

Frequency (MHz)	Average (dBµV)	Meas. Time (ms)	Bandwidth (kHz)	Filter	Line	Corr. (dB)	Margin (dB)	Limit (dBµV)	Comment
5.923500	37.2	1000.000	9.000	Off	N	9.8	12.8	50.0	
6.058500	41.7	1000.000	9.000	Off	N	9.8	8.3	50.0	
6.193500	41.8	1000.000	9.000	Off	N	9.8	8.2	50.0	



Temperature :	23.5°C	Relative Humidity :	56%
Pressure :	101 Kpa	Test Mode :	Mode 3
Test Voltage:	AC 120V/60Hz	Phase :	L

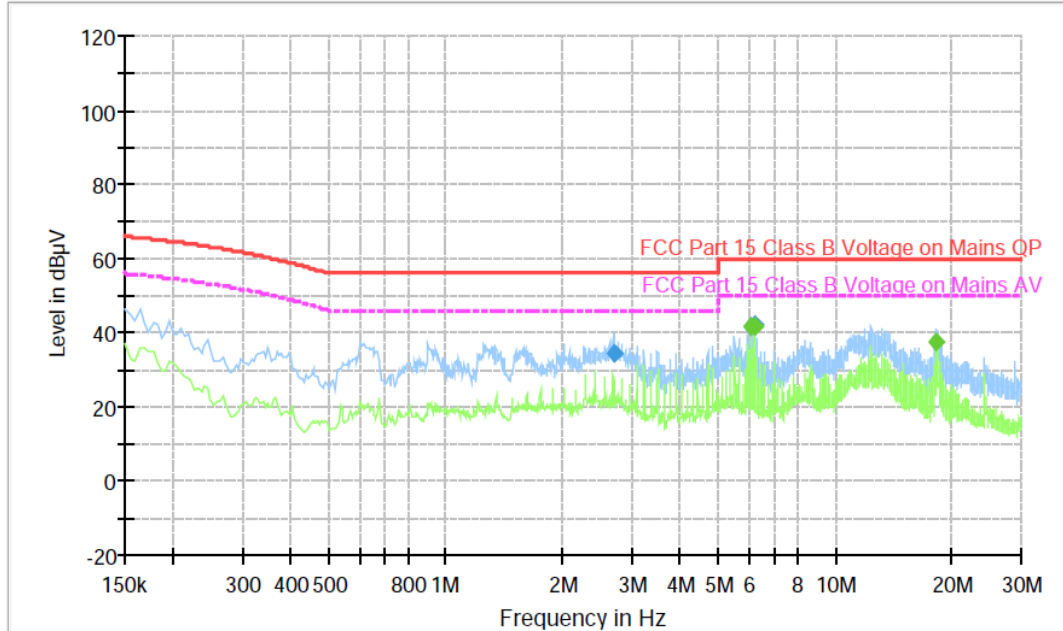

### Final Measurement Detector 1

Frequency (MHz)	QuasiPeak (dBµV)	Meas. Time (ms)	Bandwidth (kHz)	Filter	Line	Corr. (dB)	Margin (dB)	Limit (dBµV)	Comment
2.697000	34.6	1000.000	9.000	Off	L1	10.0	21.4	56.0	
6.058500	41.9	1000.000	9.000	Off	L1	9.7	18.1	60.0	
6.193500	42.1	1000.000	9.000	Off	L1	9.7	17.9	60.0	

### Final Measurement Detector 2

Frequency (MHz)	Average (dBµV)	Meas. Time (ms)	Bandwidth (kHz)	Filter	Line	Corr. (dB)	Margin (dB)	Limit (dBµV)	Comment
6.058500	41.5	1000.000	9.000	Off	L1	9.7	8.5	50.0	
6.193500	41.8	1000.000	9.000	Off	L1	9.7	8.2	50.0	
18.195000	37.6	1000.000	9.000	Off	L1	9.9	12.4	50.0	

Temperature :	23.5°C	Relative Humidity :	56%
Pressure :	101 Kpa	Test Mode :	Mode 3
Test Voltage:	AC 120V/60Hz	Phase :	N

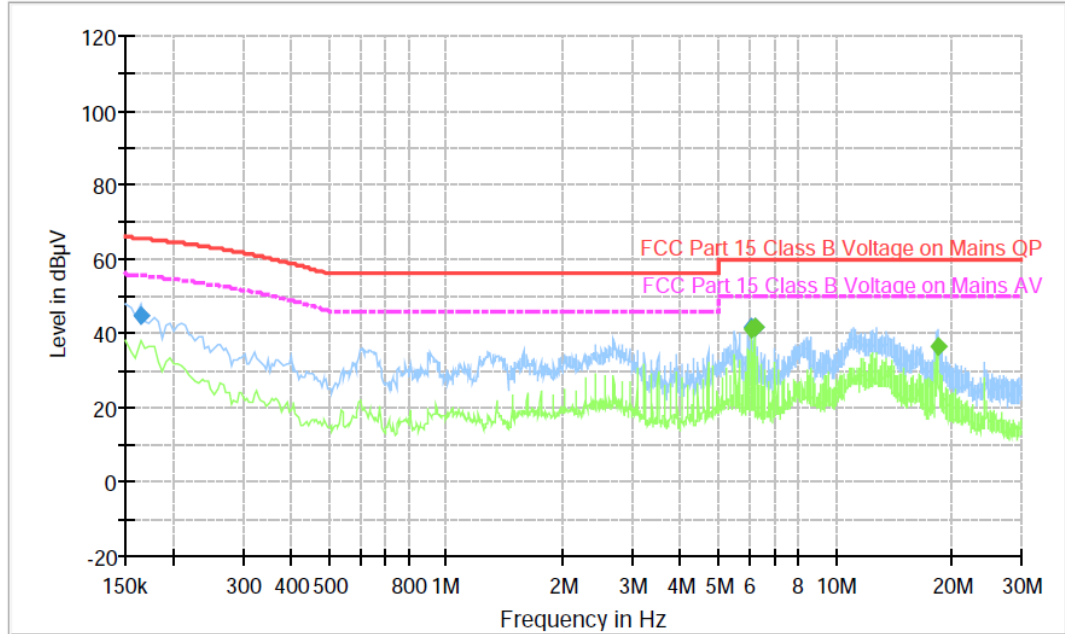

### Final Measurement Detector 1

Frequency (MHz)	QuasiPeak (dBµV)	Meas. Time (ms)	Bandwidth (kHz)	Filter	Line	Corr. (dB)	Margin (dB)	Limit (dBµV)	Comment
0.163500	44.9	1000.000	9.000	Off	N	9.6	20.7	65.6	
6.058500	41.7	1000.000	9.000	Off	N	9.8	18.3	60.0	
6.193500	41.9	1000.000	9.000	Off	N	9.8	18.1	60.0	

### Final Measurement Detector 2

Frequency (MHz)	Average (dBµV)	Meas. Time (ms)	Bandwidth (kHz)	Filter	Line	Corr. (dB)	Margin (dB)	Limit (dBµV)	Comment
6.058500	41.4	1000.000	9.000	Off	N	9.8	8.6	50.0	
6.193500	41.6	1000.000	9.000	Off	N	9.8	8.4	50.0	
18.298500	36.4	1000.000	9.000	Off	N	9.8	13.6	50.0	

Temperature :	23.5°C	Relative Humidity :	56%
Pressure :	101 Kpa	Test Mode :	Mode 4
Test Voltage:	AC 120V/60Hz	Phase :	L

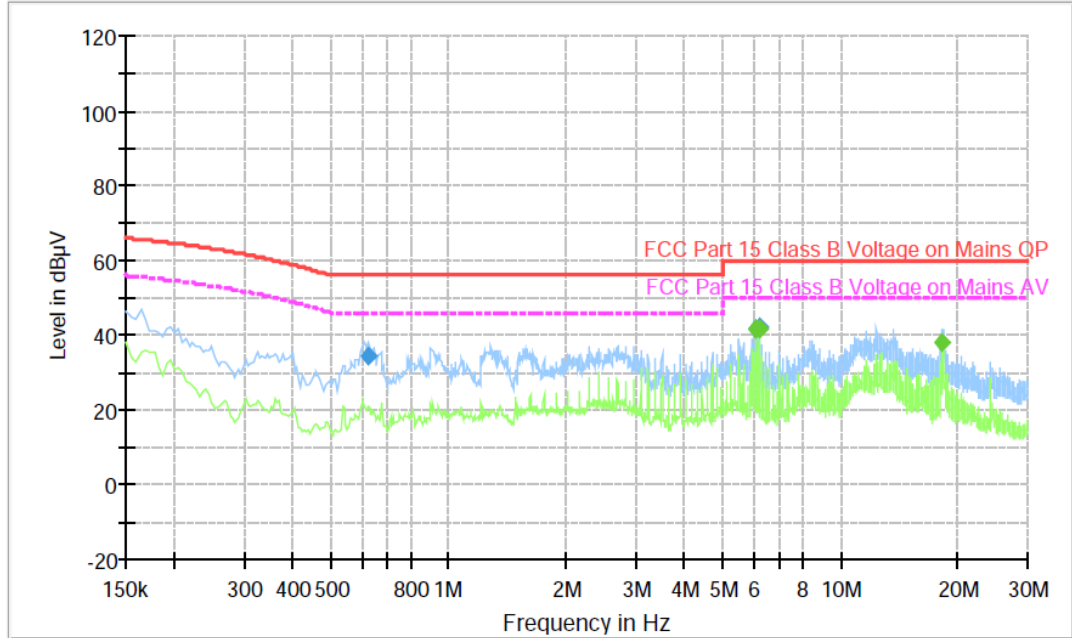

### Final Measurement Detector 1

Frequency (MHz)	QuasiPeak (dBµV)	Meas. Time (ms)	Bandwidth (kHz)	Filter	Line	Corr. (dB)	Margin (dB)	Limit (dBµV)	Comment
0.622500	34.3	1000.000	9.000	Off	L1	9.8	21.7	56.0	
6.058500	41.9	1000.000	9.000	Off	L1	9.7	18.1	60.0	
6.193500	42.1	1000.000	9.000	Off	L1	9.7	17.9	60.0	

### Final Measurement Detector 2

Frequency (MHz)	Average (dBµV)	Meas. Time (ms)	Bandwidth (kHz)	Filter	Line	Corr. (dB)	Margin (dB)	Limit (dBµV)	Comment
6.058500	41.6	1000.000	9.000	Off	L1	9.7	8.4	50.0	
6.193500	41.8	1000.000	9.000	Off	L1	9.7	8.2	50.0	
18.195000	37.9	1000.000	9.000	Off	L1	9.9	12.1	50.0	

Temperature :	23.5°C	Relative Humidity :	56%
Pressure :	101 Kpa	Test Mode :	Mode 4
Test Voltage:	AC 120V/60Hz	Phase :	N

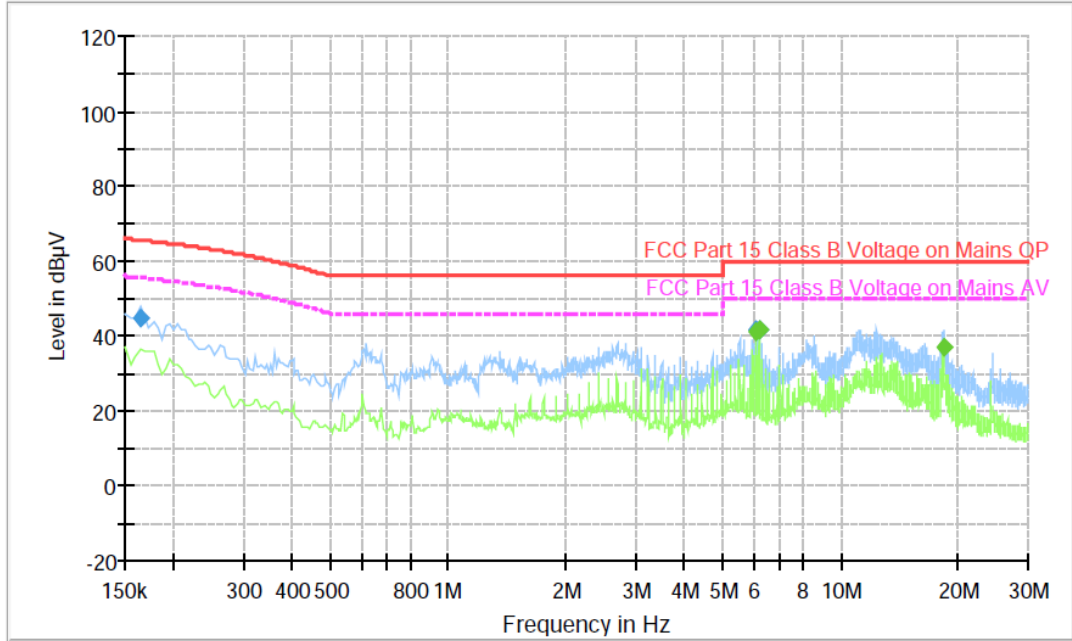

### Final Measurement Detector 1

Frequency (MHz)	QuasiPeak (dBµV)	Meas. Time (ms)	Bandwidth (kHz)	Filter	Line	Corr. (dB)	Margin (dB)	Limit (dBµV)	Comment
0.163500	44.7	1000.000	9.000	Off	N	9.6	20.9	65.6	
6.058500	41.7	1000.000	9.000	Off	N	9.8	18.3	60.0	
6.193500	41.9	1000.000	9.000	Off	N	9.8	18.1	60.0	

### Final Measurement Detector 2

Frequency (MHz)	Average (dBµV)	Meas. Time (ms)	Bandwidth (kHz)	Filter	Line	Corr. (dB)	Margin (dB)	Limit (dBµV)	Comment
6.058500	41.4	1000.000	9.000	Off	N	9.8	8.6	50.0	
6.193500	41.6	1000.000	9.000	Off	N	9.8	8.4	50.0	
18.330000	37.2	1000.000	9.000	Off	N	9.8	12.8	50.0	

Temperature :	23.5°C	Relative Humidity :	56%
Pressure :	101 Kpa	Test Mode :	Mode 5
Test Voltage:	AC 120V/60Hz	Phase :	L

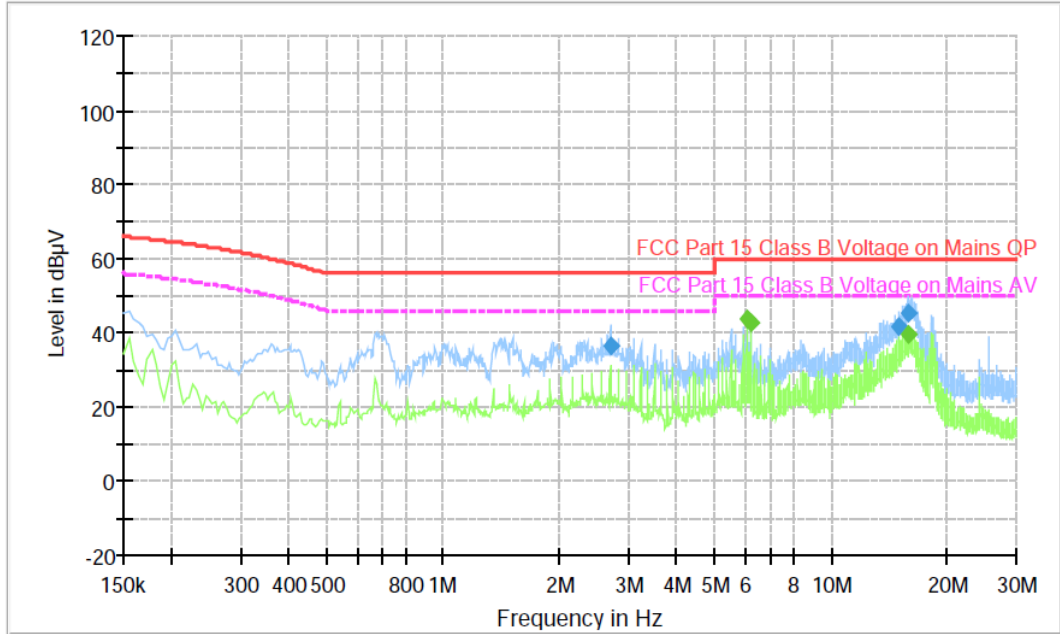

### Final Measurement Detector 1

Frequency (MHz)	QuasiPeak (dBµV)	Meas. Time (ms)	Bandwidth (kHz)	Filter	Line	Corr. (dB)	Margin (dB)	Limit (dBµV)	Comment
2.697000	36.5	1000.000	9.000	Off	L1	10.0	19.5	56.0	
14.982000	41.9	1000.000	9.000	Off	L1	9.8	18.1	60.0	
15.760500	45.2	1000.000	9.000	Off	L1	9.8	14.8	60.0	



Temperature :	23.5°C	Relative Humidity :	56%
Pressure :	101 Kpa	Test Mode :	Mode 5
Test Voltage:	AC 120V/60Hz	Phase :	N

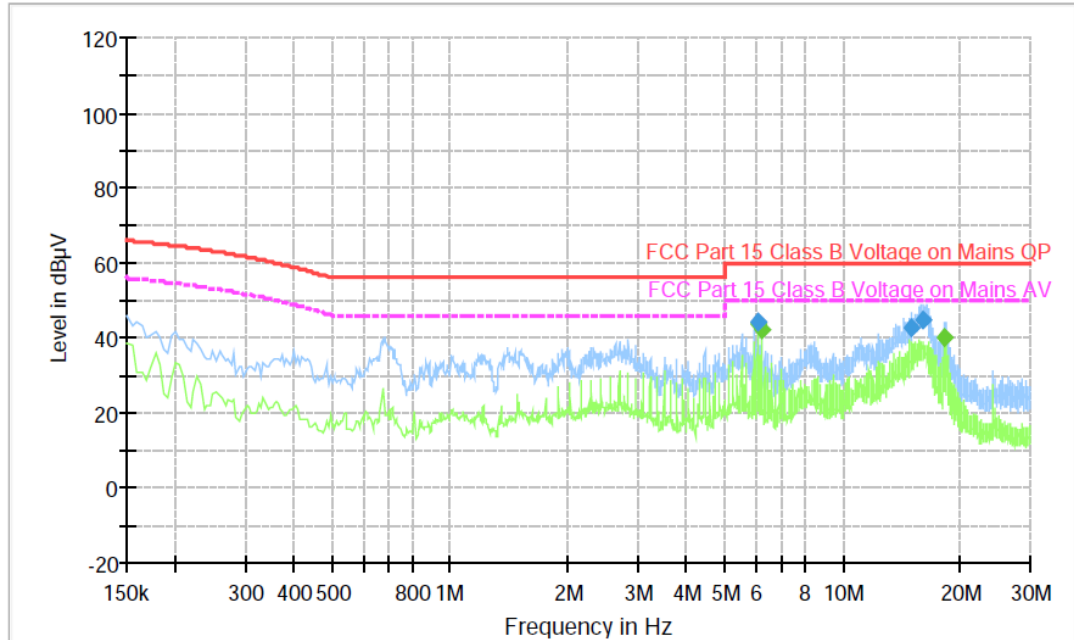

### Final Measurement Detector 1

Frequency (MHz)	QuasiPeak (dBµV)	Meas. Time (ms)	Bandwidth (kHz)	Filter	Line	Corr. (dB)	Margin (dB)	Limit (dBµV)	Comment
6.067500	44.1	1000.000	9.000	Off	N	9.8	15.9	60.0	
14.950500	42.5	1000.000	9.000	Off	N	9.8	17.5	60.0	
16.075500	44.8	1000.000	9.000	Off	N	9.8	15.2	60.0	

### Final Measurement Detector 2

Frequency (MHz)	Average (dBµV)	Meas. Time (ms)	Bandwidth (kHz)	Filter	Line	Corr. (dB)	Margin (dB)	Limit (dBµV)	Comment
6.067500	43.7	1000.000	9.000	Off	N	9.8	6.3	50.0	
6.202500	42.3	1000.000	9.000	Off	N	9.8	7.7	50.0	
18.217500	40.2	1000.000	9.000	Off	N	9.8	9.8	50.0	

Temperature :	23.5°C	Relative Humidity :	56%
Pressure :	101 Kpa	Test Mode :	Mode 6
Test Voltage:	AC 120V/60Hz	Phase :	L

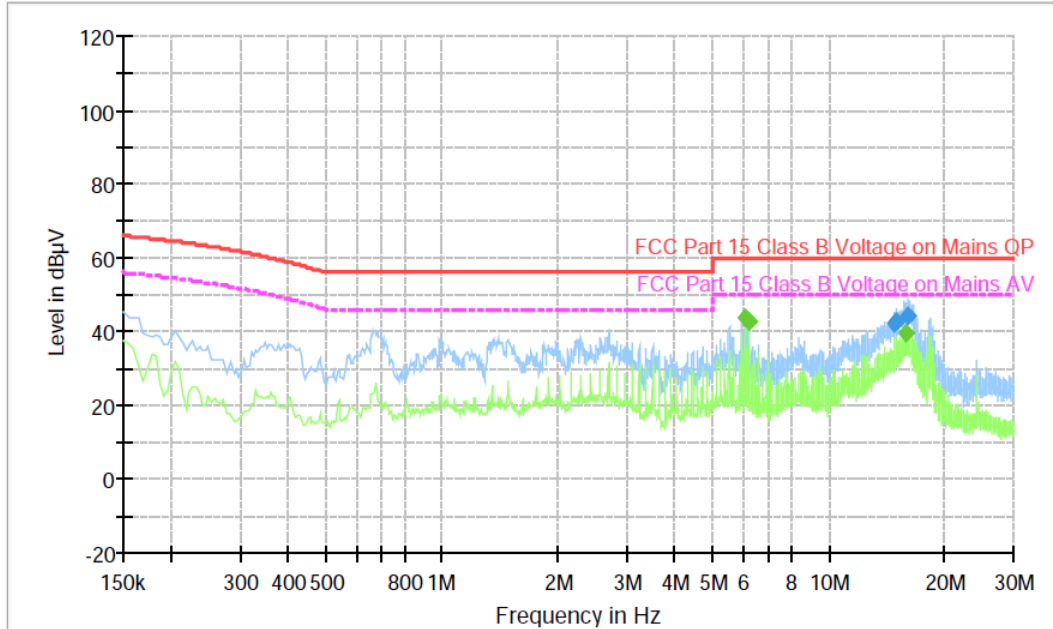

### Final Measurement Detector 1

Frequency (MHz)	QuasiPeak (dBµV)	Meas. Time (ms)	Bandwidth (kHz)	Filter	Line	Corr. (dB)	Margin (dB)	Limit (dBµV)	Comment
14.815500	42.0	1000.000	9.000	Off	L1	9.8	18.0	60.0	
14.950500	42.6	1000.000	9.000	Off	L1	9.8	17.4	60.0	
16.062000	44.3	1000.000	9.000	Off	L1	9.8	15.7	60.0	

### Final Measurement Detector 2

Frequency (MHz)	Average (dBµV)	Meas. Time (ms)	Bandwidth (kHz)	Filter	Line	Corr. (dB)	Margin (dB)	Limit (dBµV)	Comment
6.067500	43.9	1000.000	9.000	Off	L1	9.7	6.1	50.0	
6.202500	42.6	1000.000	9.000	Off	L1	9.7	7.4	50.0	
15.792000	39.6	1000.000	9.000	Off	L1	9.8	10.4	50.0	

Temperature :	23.5°C	Relative Humidity :	56%
Pressure :	101 Kpa	Test Mode :	Mode 6
Test Voltage:	AC 120V/60Hz	Phase :	N

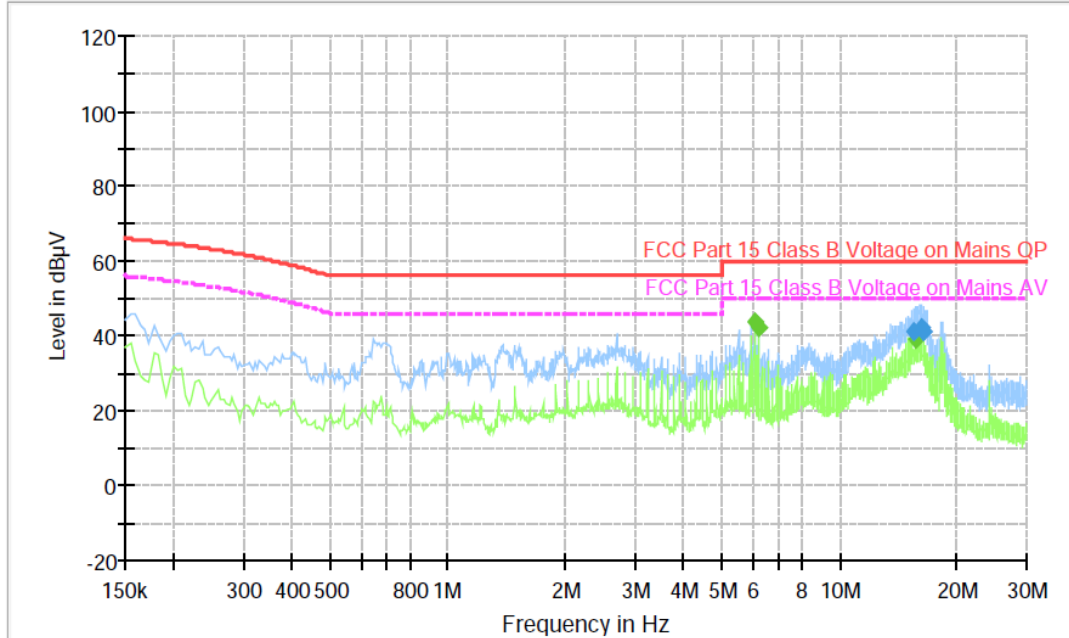

### Final Measurement Detector 1

Frequency (MHz)	QuasiPeak (dBµV)	Meas. Time (ms)	Bandwidth (kHz)	Filter	Line	Corr. (dB)	Margin (dB)	Limit (dBµV)	Comment
15.477000	41.3	1000.000	9.000	Off	N	9.8	18.7	60.0	
16.273500	42.2	1000.000	9.000	Off	N	9.8	17.8	60.0	
16.444500	41.2	1000.000	9.000	Off	N	9.8	18.8	60.0	

### Final Measurement Detector 2

Frequency (MHz)	Average (dBµV)	Meas. Time (ms)	Bandwidth (kHz)	Filter	Line	Corr. (dB)	Margin (dB)	Limit (dBµV)	Comment
6.067500	43.8	1000.000	9.000	Off	N	9.8	6.2	50.0	
6.202500	42.4	1000.000	9.000	Off	N	9.8	7.6	50.0	
15.657000	39.2	1000.000	9.000	Off	N	9.8	10.8	50.0	

## 4 RADIATED EMISSION MEASUREMENT

### 4.1 LIMITS OF RADIATED EMISSION MEASUREMENT

#### LIMITS OF RADIATED EMISSION MEASUREMENT (Below 1000MHz)

FREQUENCY (MHz)	Class A (at 10m)	Class B (at 3m)
	dBuV/m	dBuV/m
30 ~ 88	39.0	40.0
88 ~ 216	43.5	43.5
216 ~ 960	46.5	46.0
Above 960	49.5	54.0

#### LIMITS OF RADIATED EMISSION MEASUREMENT (Above 1000MHz)

FREQUENCY (MHz)	Class A (at 3m) dBuV/m		Class B (at 3m) dBuV/m	
	Peak	Avg	Peak	Avg
Above 1000	80	60	74	54

Notes:

- (1) The limit for radiated test was performed according to as following:  
FCC PART 15B /ICES-003.
- (2) The tighter limit applies at the band edges.
- (3) Emission level (dBuV/m)=20log Emission level (uV/m).

### 4.2 TEST PROCEDURE

- a. The measuring distance of at 3 m shall be used for measurements at frequency up to 1GHz. For frequencies above 1GHz, any suitable measuring distance may be used.
- b. The EUT was placed on the top of a rotating table 0.8 meters above the ground at a 3 meter test site. The table was rotated 360 degrees to determine the position of the highest radiation.
- c. The height of the equipment or of the substitution antenna shall be 0.8 m; the height of the test antenna shall vary between 1 m to 4 m. Both horizontal and vertical polarizations of the antenna are set to make the measurement.
- d. The initial step in collecting radiated emission data is a spectrum analyzer peak detector mode pre-scanning the measurement frequency range. Significant peaks are then marked and then Quasi Peak detector mode re-measured, above 1G Average detector mode will be instead.
- e. If the Peak Mode measured value compliance with and lower than Quasi Peak Mode Limit, the EUT shall be deemed to meet QP(AV) Limits and then no additional QP Mode measurement performed.
- f. For the actual test configuration, please refer to the related Item –EUT Test Photos.

### 4.3 TEST SETUP

#### (A) Radiated Emission Test Set-up, Frequency Below 1000MHz

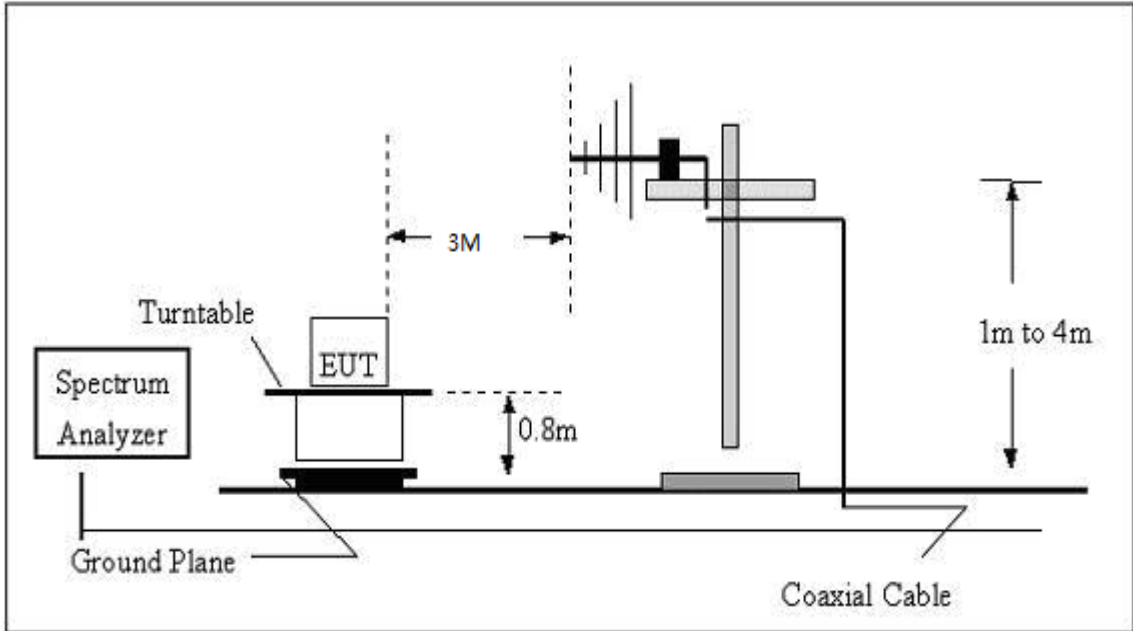

#### (B) Radiated Emission Test Set-up, Frequency Over 1GHz

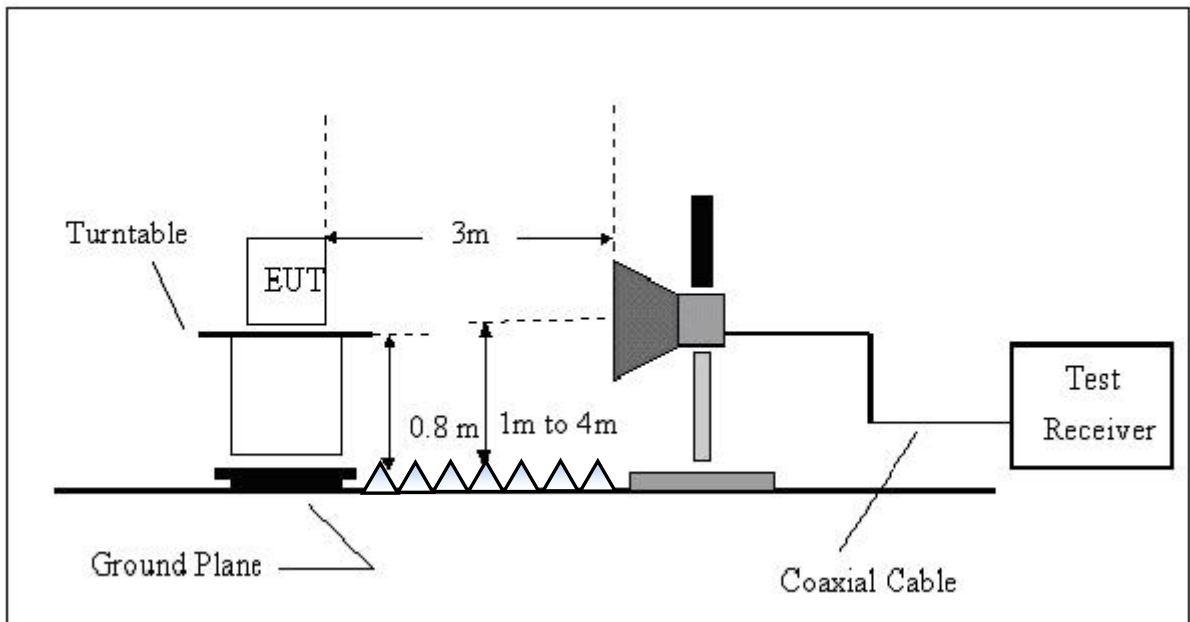

### 4.4 EUT OPERATING CONDITIONS

The EUT tested system was configured as the statements of 2.1 Unless otherwise a special operating condition is specified in the follows during the testing.



4.5 TEST RESULTS

Temperature:	24.2°C	Relative Humidity:	57%
Pressure:	101 Kpa	Test Mode:	Mode 1
Polarization:	Vertical	Test Power:	AC 120V/60Hz

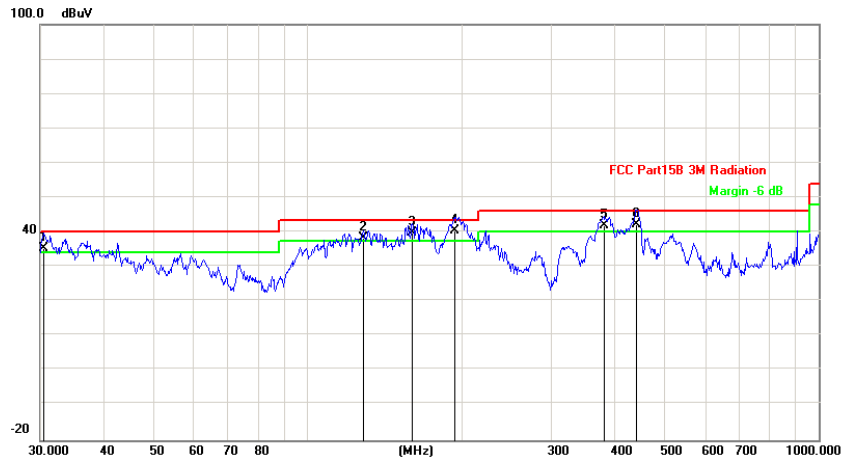

No.	Frequency (MHz)	Factor (dB)	Reading (dBuV)	Level (dBuV)	Limit (dBuV)	Margin (dB)	Detector	Height (cm)	Azimuth ( )	P/F	Remark
1	30.5304	-3.85	39.35	35.50	40.00	-4.50	QP			P	
2	128.5629	-13.56	51.76	38.20	43.50	-5.30	QP			P	
3	160.3454	-15.72	55.72	40.00	43.50	-3.50	QP			P	
4	194.4533	-13.64	54.04	40.40	43.50	-3.10	QP			P	
5	379.9141	-9.53	51.53	42.00	46.00	-4.00	QP			P	
6	440.1961	-8.16	50.46	42.30	46.00	-3.70	QP			P	

30~1000MHz

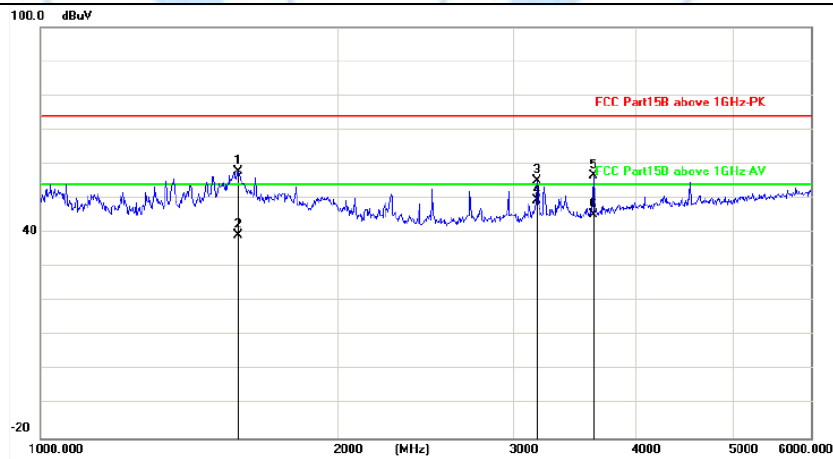

No.	Frequency (MHz)	Factor (dB)	Reading (dBuV)	Level (dBuV)	Limit (dBuV)	Margin (dB)	Detector	Height (cm)	Azimuth ( )	P/F	Remark
1	1582.001	-6.36	64.12	57.76	74.00	-16.24	peak			P	
2	1582.001	-6.36	45.66	39.30	54.00	-14.70	AVG			P	
3	3170.512	-2.42	57.46	55.04	74.00	-18.96	peak			P	
4	3170.512	-2.42	51.92	49.50	54.00	-4.50	AVG			P	
5	3620.034	-1.00	57.70	56.70	74.00	-17.30	peak			P	
6	3620.034	-1.00	46.40	45.40	54.00	-8.60	AVG			P	

1000~6000MHz

Shenzhen General Testing & Inspection Technology Co., Ltd.

1-2/F., Building 2, Jiaquan Building, Guanlan High-Tech Park, Shenzhen, Guangdong, China

Tel.: (86)755-27521059

Fax.: (86)755-27521011

Http://www.sz-ctc.org.cn



Temperature:	24.2°C	Relative Humidity:	57%
Pressure:	101 Kpa	Test Mode:	Mode 1
Polarization:	Horizontal	Test Power:	AC 120V/60Hz

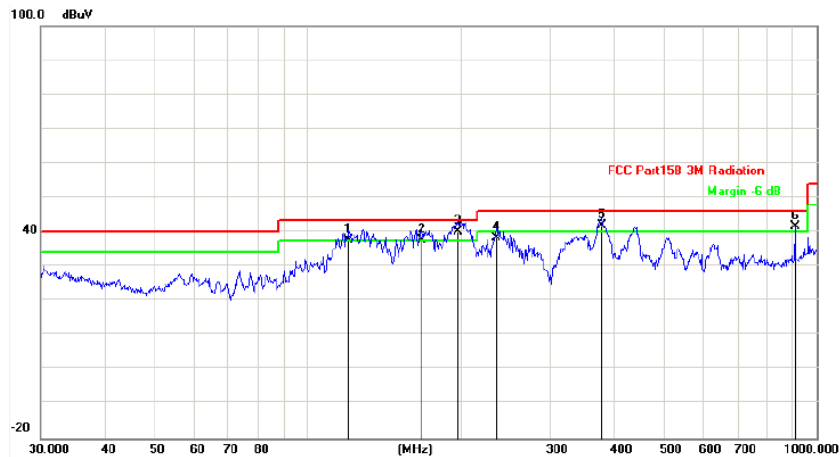

No.	Frequency (MHz)	Factor (dB)	Reading (dBuV)	Level (dBuV)	Limit (dBuV)	Margin (dB)	Detector	Height (cm)	Azimuth ( )	P/F	Remark
1	120.6991	-13.40	51.10	37.70	43.50	-5.80	QP			P	
2	167.8242	-15.41	53.21	37.80	43.50	-5.70	QP			P	
3	197.8928	-13.35	53.65	40.30	43.50	-3.20	QP			P	
4	234.9909	-13.06	51.36	38.30	46.00	-7.70	QP			P	
5	378.5842	-9.60	51.70	42.10	46.00	-3.90	QP			P	
6	906.4824	-1.24	42.94	41.70	46.00	-4.30	QP			P	

30~1000MHz

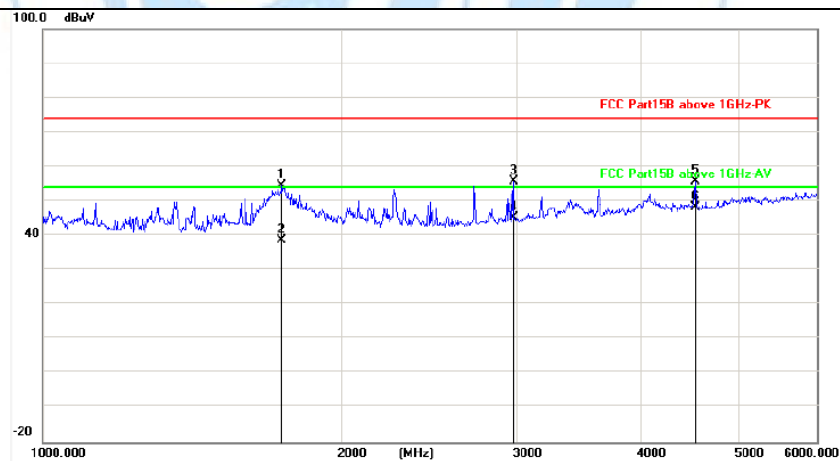

No.	Frequency (MHz)	Factor (dB)	Reading (dBuV)	Level (dBuV)	Limit (dBuV)	Margin (dB)	Detector	Height (cm)	Azimuth ( )	P/F	Remark
1	1739.597	-6.01	60.68	54.67	74.00	-19.33	peak			P	
2	1739.597	-6.01	44.81	38.80	54.00	-15.20	AVG			P	
3	2972.459	-2.73	58.53	55.80	74.00	-18.20	peak			P	
4	2972.459	-2.73	48.13	45.40	54.00	-8.60	AVG			P	
5	4528.783	1.66	54.18	55.84	74.00	-18.16	peak			P	
6	4528.783	1.66	46.44	48.10	54.00	-5.90	AVG			P	

1000~6000MHz

Shenzhen General Testing & Inspection Technology Co., Ltd.

1-2/F., Building 2, Jiaquan Building, Guanlan High-Tech Park, Shenzhen, Guangdong, China

Tel.: (86)755-27521059

Fax.: (86)755-27521011 Http://www.sz-cti.org.cn



For anti-fake verification, please visit the official website of Certification and Accreditation Administration of the People's Republic of China : [yz.cncaic.cn](http://yz.cncaic.cn)

Temperature:	24.2°C	Relative Humidity:	57%
Pressure:	101 Kpa	Test Mode:	Mode 2
Polarization:	Vertical	Test Power:	AC 120V/60Hz

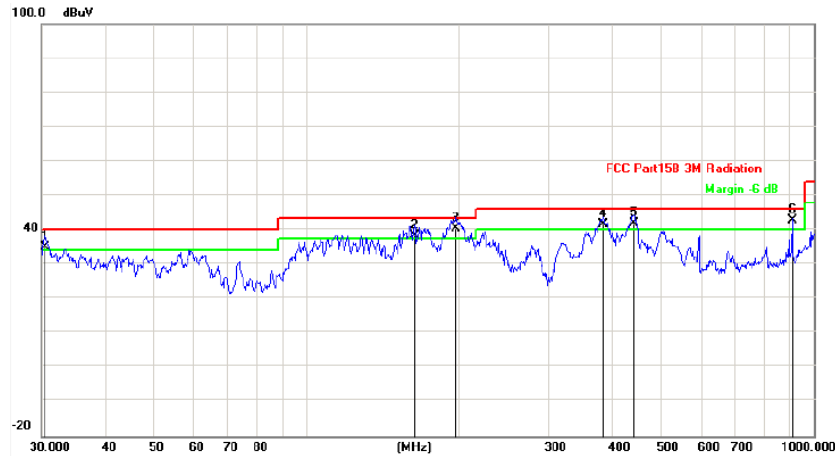

No.	Frequency (MHz)	Factor (dB)	Reading (dBuV)	Level (dBuV)	Limit (dBuV)	Margin (dB)	Detector	Height (cm)	Azimuth ( )	P/F	Remark
1	30.4237	-3.80	38.90	35.10	40.00	-4.90	QP			P	
2	163.1817	-15.61	53.81	38.20	43.50	-5.30	QP			P	
3	197.2000	-13.41	53.81	40.40	43.50	-3.10	QP			P	
4	383.9318	-9.33	51.03	41.70	46.00	-4.30	QP			P	
5	441.7425	-8.14	50.24	42.10	46.00	-3.90	QP			P	
6	906.4823	-1.24	44.24	43.00	46.00	-3.00	QP			P	

30~1000MHz

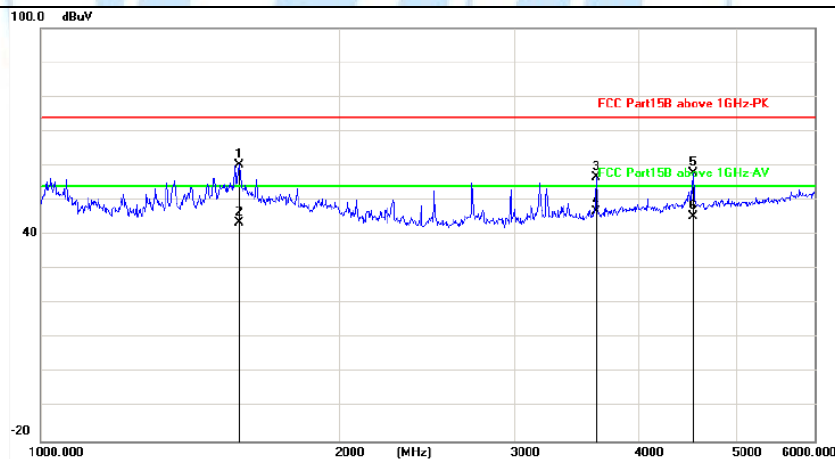

No.	Frequency (MHz)	Factor (dB)	Reading (dBuV)	Level (dBuV)	Limit (dBuV)	Margin (dB)	Detector	Height (cm)	Azimuth ( )	P/F	Remark
1	1582.001	-6.36	66.62	60.26	74.00	-13.74	peak			P	
2	1582.001	-6.36	49.96	43.60	54.00	-10.40	AVG			P	
3	3620.034	-1.00	57.70	56.70	74.00	-17.30	peak			P	
4	3620.034	-1.00	47.60	46.60	54.00	-7.40	AVG			P	
5	4528.783	1.66	56.29	57.95	74.00	-16.05	peak			P	
6	4528.783	1.66	43.54	45.20	54.00	-8.80	AVG			P	

1000~6000MHz

Shenzhen General Testing & Inspection Technology Co., Ltd.

1-2/F., Building 2, Jiaquan Building, Guanlan High-Tech Park, Shenzhen, Guangdong, China

Tel.: (86)755-27521059

Fax.: (86)755-27521011

Http://www.sz.ctic.org.cn



中国国家认证认可监督管理委员会  
Certification and Accreditation Administration of the People's Republic of China

For anti-fake verification, please visit the official website of Certification and Accreditation Administration of the People's Republic of China : [yz.cncaic.cn](http://yz.cncaic.cn)

Temperature:	24.2°C	Relative Humidity:	57%
Pressure:	101 Kpa	Test Mode:	Mode 2
Polarization:	Horizontal	Test Power:	AC 120V/60Hz

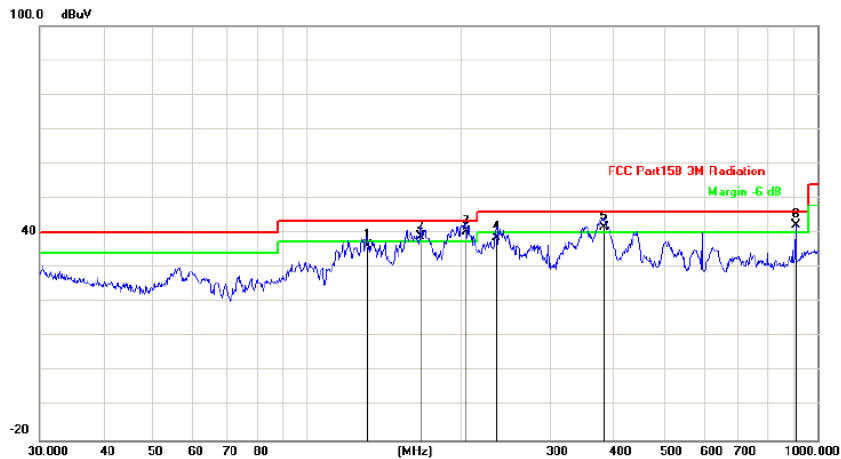

No.	Frequency (MHz)	Factor (dB)	Reading (dBuV)	Level (dBuV)	Limit (dBuV)	Margin (dB)	Detector	Height (cm)	Azimuth (°)	P/F	Remark
1	131.7574	-13.62	49.92	36.30	43.50	-7.20	QP			P	
2	167.2366	-15.45	54.35	38.90	43.50	-4.60	QP			P	
3	204.9550	-12.98	53.38	40.40	43.50	-3.10	QP			P	
4	234.9909	-13.06	51.86	38.80	46.00	-7.20	QP			P	
5	382.5878	-9.40	51.20	41.80	46.00	-4.20	QP			P	
6	906.4823	-1.24	43.64	42.40	46.00	-3.60	QP			P	

30~1000MHz

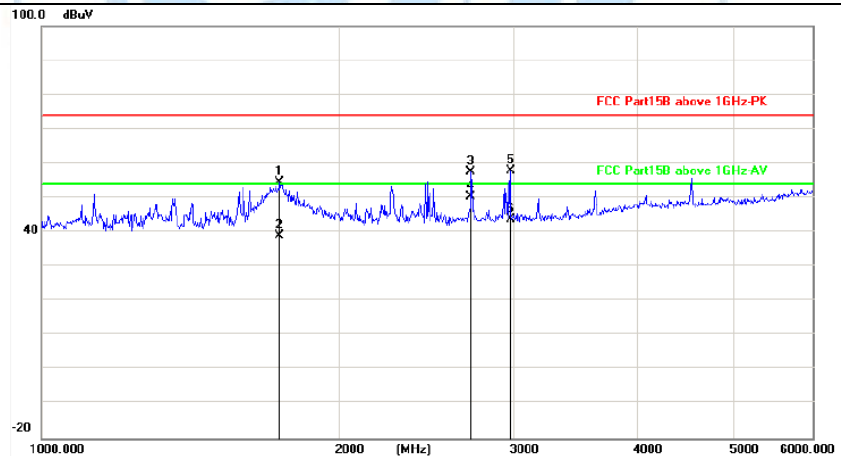

No.	Frequency (MHz)	Factor (dB)	Reading (dBuV)	Level (dBuV)	Limit (dBuV)	Margin (dB)	Detector	Height (cm)	Azimuth (°)	P/F	Remark
1	1739.597	-6.01	60.68	54.67	74.00	-19.33	peak			P	
2	1739.597	-6.01	44.91	38.90	54.00	-15.10	AVG			P	
3	2712.878	-3.01	60.62	57.61	74.00	-16.39	peak			P	
4	2712.878	-3.01	53.51	50.50	54.00	-3.50	AVG			P	
5	2972.459	-2.73	60.53	57.80	74.00	-16.20	peak			P	
6	2972.459	-2.73	46.63	43.90	54.00	-10.10	AVG			P	

1000~6000MHz

Shenzhen General Testing & Inspection Technology Co., Ltd.

1-2/F., Building 2, Jiaquan Building, Guanlan High-Tech Park, Shenzhen, Guangdong, China

Tel.: (86)755-27521059

Fax.: (86)755-27521011 Http://www.sz-ctc.org.cn



For anti-fake verification, please visit the official website of Certification and Accreditation Administration of the People's Republic of China : [yz.cncaic.cn](http://yz.cncaic.cn)

Temperature:	24.2°C	Relative Humidity:	57%
Pressure:	101 Kpa	Test Mode:	Mode 3
Polarization:	Vertical	Test Power:	AC 120V/60Hz

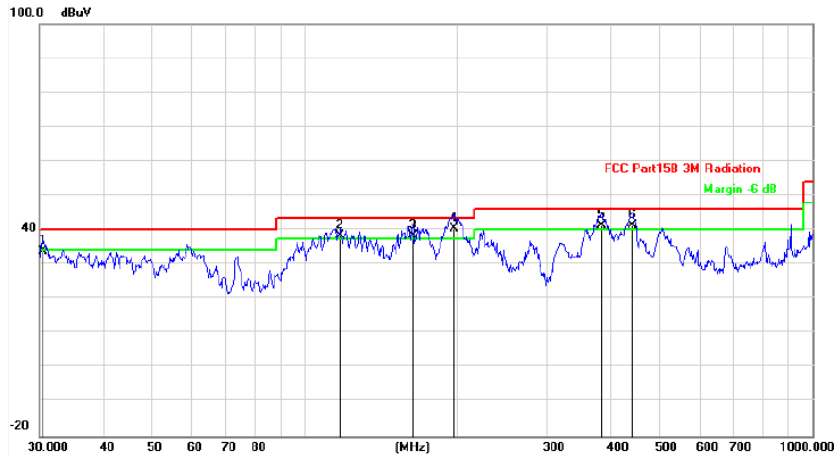

No.	Frequency (MHz)	Factor (dB)	Reading (dBuV)	Level (dBuV)	Limit (dBuV)	Margin (dB)	Detector	Height (cm)	Azimuth ( )	P/F	Remark
1	30.4237	-3.75	37.55	33.80	40.00	-6.20	QP			P	
2	117.3602	-13.47	51.97	38.50	43.50	-5.00	QP			P	
3	163.1817	-15.61	53.91	38.30	43.50	-5.20	QP			P	
4	197.2001	-13.41	53.81	40.40	43.50	-3.10	QP			P	
5	383.9318	-9.33	50.53	41.20	46.00	-4.80	QP			P	
6	441.7425	-8.14	49.54	41.40	46.00	-4.60	QP			P	

30~1000MHz

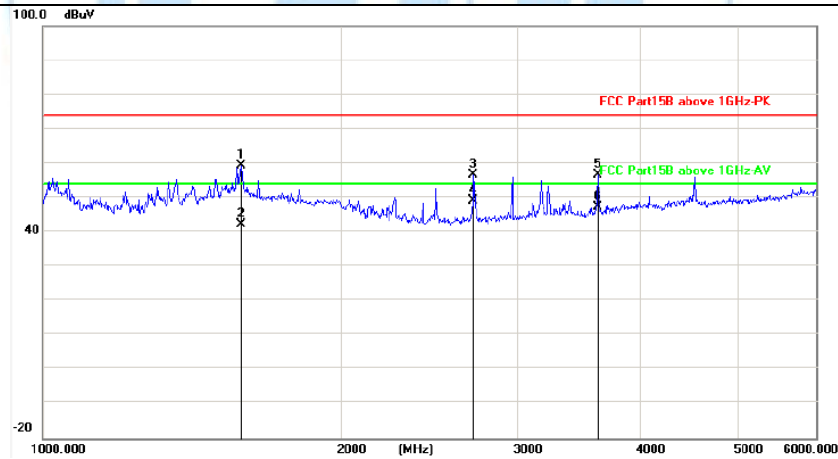

No.	Frequency (MHz)	Factor (dB)	Reading (dBuV)	Level (dBuV)	Limit (dBuV)	Margin (dB)	Detector	Height (cm)	Azimuth ( )	P/F	Remark
1	1582.001	-6.36	65.62	59.26	74.00	-14.74	peak			P	
2	1582.001	-6.36	48.56	42.20	54.00	-11.80	AVG			P	
3	2712.878	-3.01	59.60	56.59	74.00	-17.41	peak			P	
4	2712.878	-3.01	52.31	49.30	54.00	-4.70	AVG			P	
5	3620.034	-1.00	57.70	56.70	74.00	-17.30	peak			P	
6	3620.034	-1.00	48.20	47.20	54.00	-6.80	AVG			P	

1000~6000MHz

Shenzhen General Testing & Inspection Technology Co., Ltd.

1-2/F., Building 2, Jiaquan Building, Guanlan High-Tech Park, Shenzhen, Guangdong, China

Tel.: (86)755-27521059

Fax.: (86)755-27521011

Http://www.sz-ctg.org.cn





Temperature:	24.2°C	Relative Humidity:	57%
Pressure:	101 Kpa	Test Mode:	Mode 3
Polarization:	Horizontal	Test Power:	AC 120V/60Hz

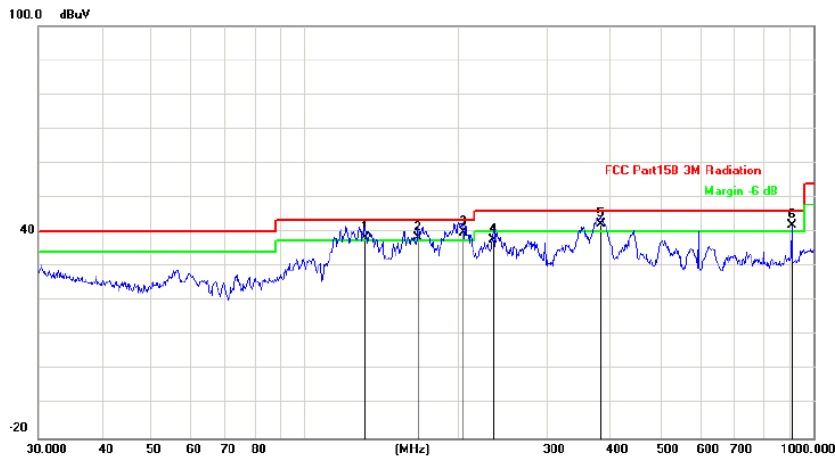

No.	Frequency (MHz)	Factor (dB)	Reading (dBuV)	Level (dBuV)	Limit (dBuV)	Margin (dB)	Detector	Height (cm)	Azimuth ( )	P/F	Remark
1	131.7575	-13.62	51.82	38.20	43.50	-5.30	QP			P	
2	167.2366	-15.45	53.95	38.50	43.50	-5.00	QP			P	
3	204.9550	-12.98	52.98	40.00	43.50	-3.50	QP			P	
4	234.9909	-13.06	50.76	37.70	46.00	-8.30	QP			P	
5	382.5878	-9.40	51.60	42.20	46.00	-3.80	QP			P	
6	906.4823	-1.24	43.14	41.90	46.00	-4.10	QP			P	

30~1000MHz

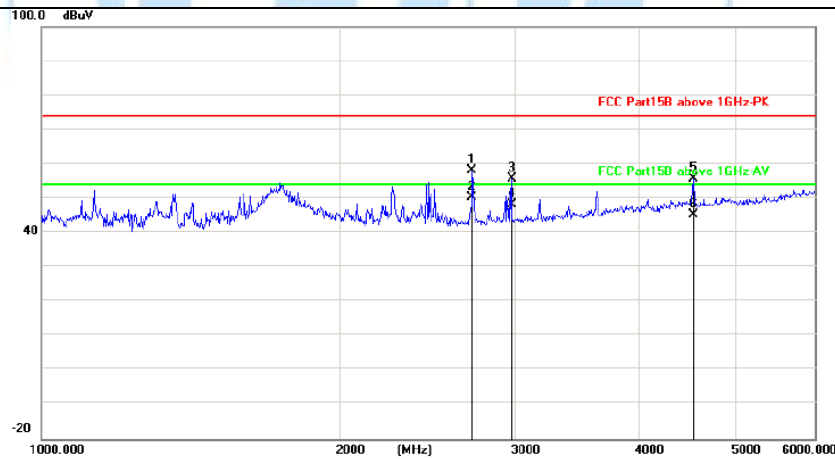

No.	Frequency (MHz)	Factor (dB)	Reading (dBuV)	Level (dBuV)	Limit (dBuV)	Margin (dB)	Detector	Height (cm)	Azimuth ( )	P/F	Remark
1	2712.878	-3.01	61.12	58.11	74.00	-15.89	peak			P	
2	2712.878	-3.01	53.31	50.30	54.00	-3.70	AVG			P	
3	2972.459	-2.73	58.53	55.80	74.00	-18.20	peak			P	
4	2972.459	-2.73	51.03	48.30	54.00	-5.70	AVG			P	
5	4528.783	1.66	54.18	55.84	74.00	-18.16	peak			P	
6	4528.783	1.66	43.54	45.20	54.00	-8.80	AVG			P	

1000~6000MHz

Shenzhen General Testing & Inspection Technology Co., Ltd.

1-2/F., Building 2, Jiaquan Building, Guanlan High-Tech Park, Shenzhen, Guangdong, China

Tel.: (86)755-27521059

Fax.: (86)755-27521011 Http://www.sz-ctc.org.cn



For anti-fake verification, please visit the official website of Certification and Accreditation Administration of the People's Republic of China : [yz.cncaic.cn](http://yz.cncaic.cn)

Temperature:	24.2°C	Relative Humidity:	57%
Pressure:	101 Kpa	Test Mode:	Mode 4
Polarization:	Vertical	Test Power:	AC 120V/60Hz

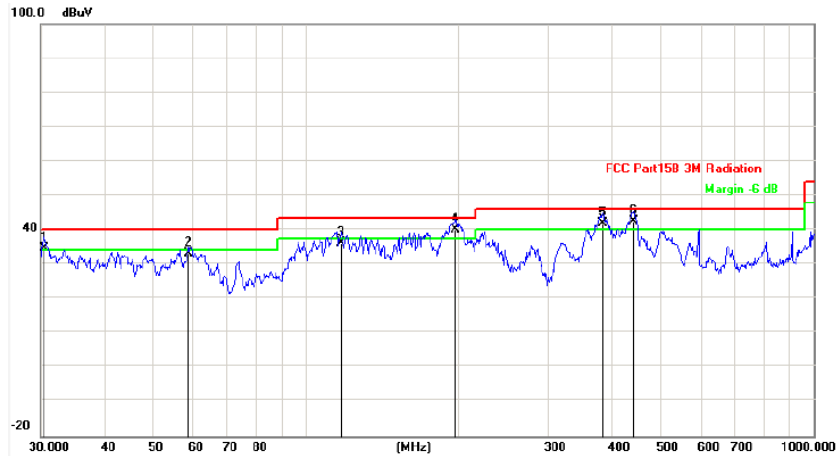

No.	Frequency (MHz)	Factor (dB)	Reading (dBuV)	Level (dBuV)	Limit (dBuV)	Margin (dB)	Detector	Height (cm)	Azimuth (°)	P/F	Remark
1	30.4237	-3.75	38.55	34.80	40.00	-5.20	QP			P	
2	58.6126	-13.83	47.03	33.20	40.00	-6.80	QP			P	
3	117.3602	-13.47	49.77	36.30	43.50	-7.20	QP			P	
4	197.2000	-13.41	53.51	40.10	43.50	-3.40	QP			P	
5	383.9318	-9.33	51.43	42.10	46.00	-3.90	QP			P	
6	441.7425	-8.14	50.64	42.50	46.00	-3.50	QP			P	

30~1000MHz

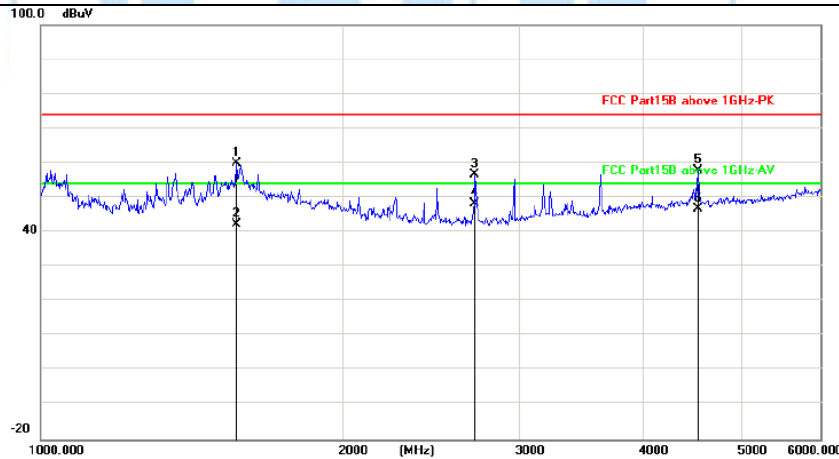

No.	Frequency (MHz)	Factor (dB)	Reading (dBuV)	Level (dBuV)	Limit (dBuV)	Margin (dB)	Detector	Height (cm)	Azimuth (°)	P/F	Remark
1	1567.891	-6.37	66.18	59.81	74.00	-14.19	peak			P	
2	1567.891	-6.37	48.57	42.20	54.00	-11.80	AVG			P	
3	2712.878	-3.01	59.60	56.59	74.00	-17.41	peak			P	
4	2712.878	-3.01	51.21	48.20	54.00	-5.80	AVG			P	
5	4528.783	1.66	56.29	57.95	74.00	-16.05	peak			P	
6	4528.783	1.66	45.24	46.90	54.00	-7.10	AVG			P	

1000~6000MHz

Shenzhen General Testing & Inspection Technology Co., Ltd.

1-2/F., Building 2, Jiaquan Building, Guanlan High-Tech Park, Shenzhen, Guangdong, China

Tel.: (86)755-27521059

Fax.: (86)755-27521011

Http://www.sz.ctic.org.cn



For anti-fake verification, please visit the official website of Certification and Accreditation Administration of the People's Republic of China : [yz.cncaic.cn](http://yz.cncaic.cn)



Temperature:	24.2°C	Relative Humidity:	57%
Pressure:	101 Kpa	Test Mode:	Mode 4
Polarization:	Horizontal	Test Power:	AC 120V/60Hz

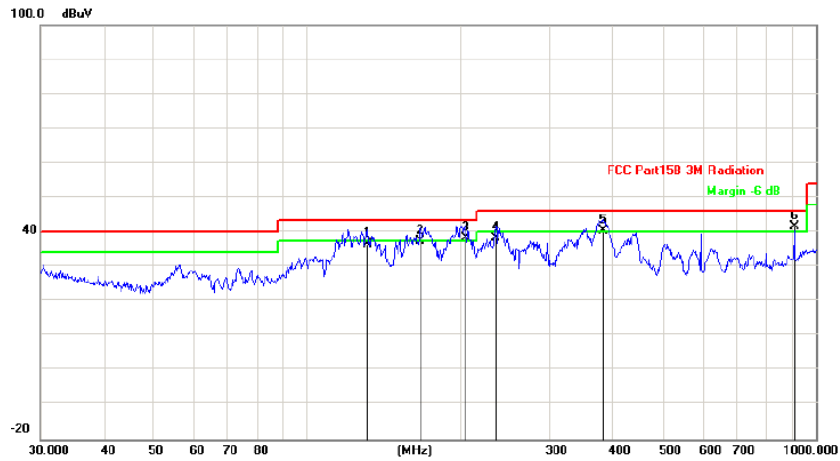

No.	Frequency (MHz)	Factor (dB)	Reading (dBuV)	Level (dBuV)	Limit (dBuV)	Margin (dB)	Detector	Height (cm)	Azimuth ( )	P/F	Remark
1	131.7576	-13.63	50.23	36.60	43.50	-6.90	QP			P	
2	167.2366	-15.45	52.85	37.40	43.50	-6.10	QP			P	
3	204.9550	-12.98	51.28	38.30	43.50	-5.20	QP			P	
4	234.9909	-13.06	51.56	38.50	46.00	-7.50	QP			P	
5	382.5878	-9.40	49.80	40.40	46.00	-5.60	QP			P	
6	906.4823	-1.24	43.04	41.80	46.00	-4.20	QP			P	

30~1000MHz

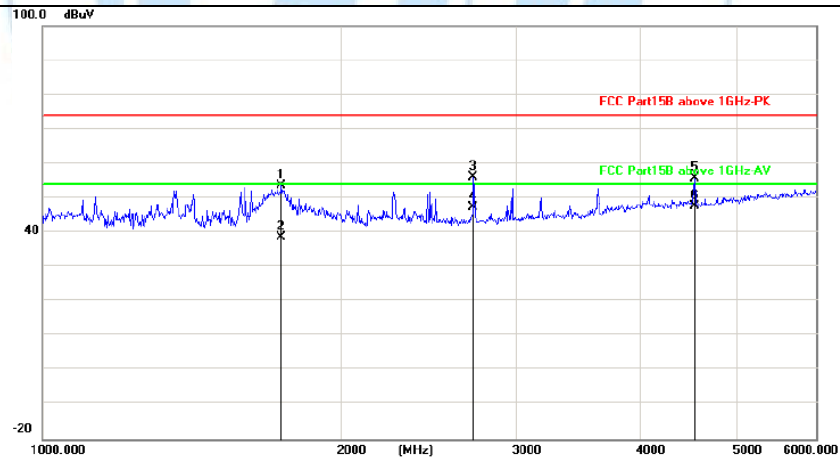

No.	Frequency (MHz)	Factor (dB)	Reading (dBuV)	Level (dBuV)	Limit (dBuV)	Margin (dB)	Detector	Height (cm)	Azimuth ( )	P/F	Remark
1	1739.597	-6.01	59.68	53.67	74.00	-20.33	peak			P	
2	1739.597	-6.01	44.81	38.80	54.00	-15.20	AVG			P	
3	2712.878	-3.01	59.12	56.11	74.00	-17.89	peak			P	
4	2712.878	-3.01	50.31	47.30	54.00	-6.70	AVG			P	
5	4528.783	1.66	54.18	55.84	74.00	-18.16	peak			P	
6	4528.783	1.66	46.14	47.80	54.00	-6.20	AVG			P	

1000~6000MHz

Shenzhen General Testing & Inspection Technology Co., Ltd.

1-2/F., Building 2, Jiaquan Building, Guanlan High-Tech Park, Shenzhen, Guangdong, China  
 Tel.: (86)755-27521059 Fax.: (86)755-27521011 Http://www.sz.ctic.org.cn



For anti-fake verification, please visit the official website of Certification and Accreditation Administration of the People's Republic of China : [yz.cncaic.cn](http://yz.cncaic.cn)

Temperature:	24.2°C	Relative Humidity:	57%
Pressure:	101 Kpa	Test Mode:	Mode 5
Polarization:	Vertical	Test Power:	AC 120V/60Hz

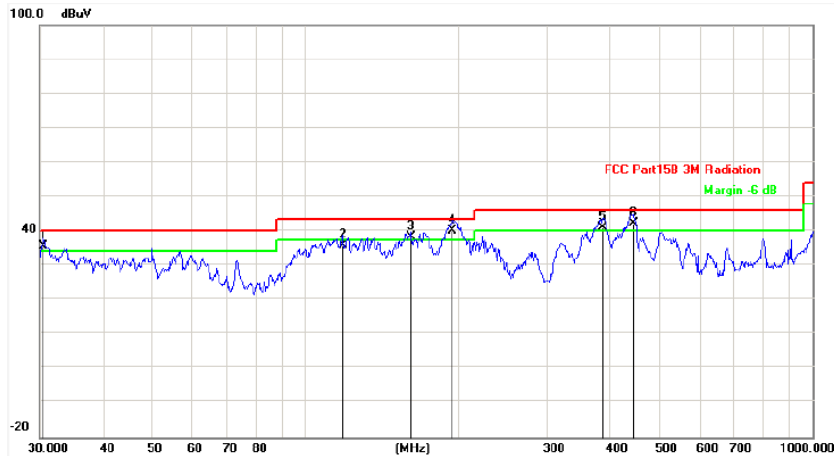

No.	Frequency (MHz)	Factor (dB)	Reading (dBuV)	Level (dBuV)	Limit (dBuV)	Margin (dB)	Detector	Height (cm)	Azimuth ( )	P/F	Remark
1	30.5304	-3.85	39.45	35.60	40.00	-4.40	QP			P	
2	118.6012	-13.44	49.34	35.90	43.50	-7.60	QP			P	
3	161.4738	-15.67	54.17	38.50	43.50	-5.00	QP			P	
4	195.1363	-13.59	53.69	40.10	43.50	-3.40	QP			P	
5	386.6338	-9.18	50.28	41.10	46.00	-4.90	QP			P	
6	443.2941	-8.14	50.34	42.20	46.00	-3.80	QP			P	

30~1000MHz

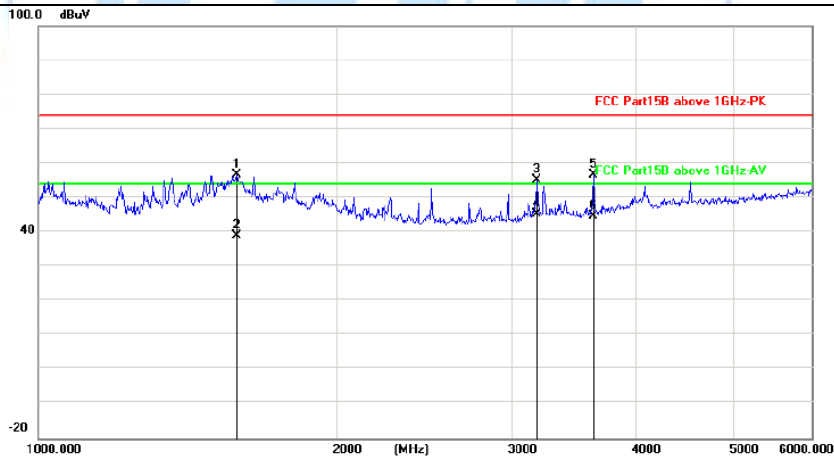

No.	Frequency (MHz)	Factor (dB)	Reading (dBuV)	Level (dBuV)	Limit (dBuV)	Margin (dB)	Detector	Height (cm)	Azimuth ( )	P/F	Remark
1	1582.001	-6.36	63.12	56.76	74.00	-17.24	peak			P	
2	1582.001	-6.36	45.26	38.90	54.00	-15.10	AVG			P	
3	3170.512	-2.42	57.46	55.04	74.00	-18.96	peak			P	
4	3170.512	-2.42	47.62	45.20	54.00	-8.80	AVG			P	
5	3620.034	-1.00	57.70	56.70	74.00	-17.30	peak			P	
6	3620.034	-1.00	45.60	44.60	54.00	-9.40	AVG			P	

1000~6000MHz

Shenzhen General Testing & Inspection Technology Co., Ltd.

1-2/F., Building 2, Jiaquan Building, Guanlan High-Tech Park, Shenzhen, Guangdong, China

Tel.: (86)755-27521059

Fax.: (86)755-27521011

Http://www.sz.ctic.org.cn



中国国家认证认可监督管理委员会  
Certification and Accreditation Administration of the People's Republic of China

For anti-fake verification, please visit the official website of Certification and Accreditation Administration of the People's Republic of China : [yz.cncaic.cn](http://yz.cncaic.cn)

Temperature:	24.2°C	Relative Humidity:	57%
Pressure:	101 Kpa	Test Mode:	Mode 5
Polarization:	Horizontal	Test Power:	AC 120V/60Hz

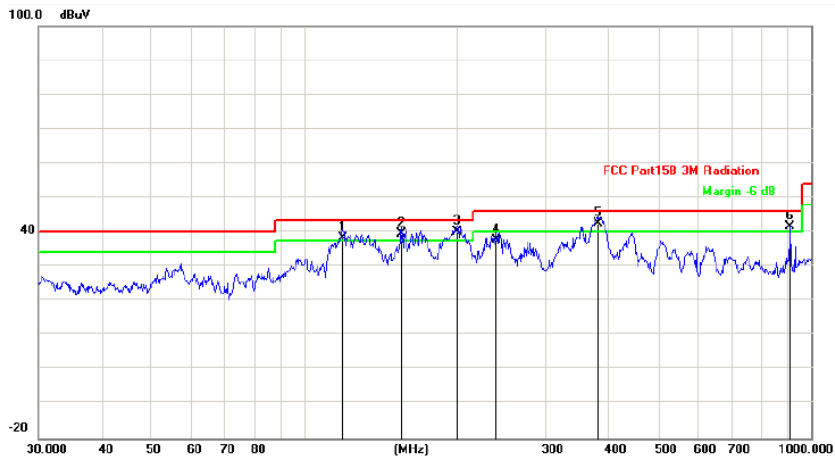

No.	Frequency (MHz)	Factor (dB)	Reading (dBuV)	Level (dBuV)	Limit (dBuV)	Margin (dB)	Detector	Height (cm)	Azimuth (°)	P/F	Remark
1	119.4360	-13.41	51.61	38.20	43.50	-5.30	QP			P	
2	155.9097	-15.36	54.96	39.60	43.50	-3.90	QP			P	
3	200.6879	-13.15	53.25	40.10	43.50	-3.40	QP			P	
4	239.9873	-13.48	51.28	37.80	46.00	-8.20	QP			P	
5	379.9141	-9.53	52.13	42.60	46.00	-3.40	QP			P	
6	909.6666	-0.93	42.73	41.80	46.00	-4.20	QP			P	

30~1000MHz

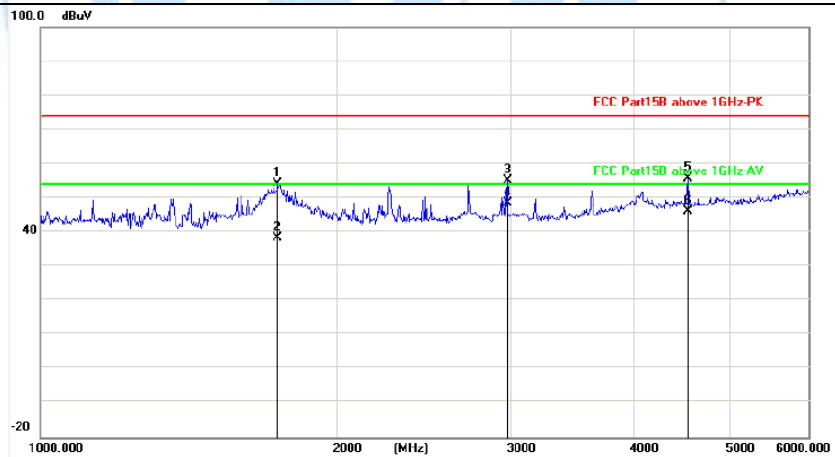

No.	Frequency (MHz)	Factor (dB)	Reading (dBuV)	Level (dBuV)	Limit (dBuV)	Margin (dB)	Detector	Height (cm)	Azimuth (°)	P/F	Remark
1	1739.597	-6.01	60.18	54.17	74.00	-19.83	peak			P	
2	1739.597	-6.01	44.51	38.50	54.00	-15.50	AVG			P	
3	2972.459	-2.73	58.03	55.30	74.00	-18.70	peak			P	
4	2972.459	-2.73	51.23	48.50	54.00	-5.50	AVG			P	
5	4528.783	1.66	54.18	55.84	74.00	-18.16	peak			P	
6	4528.783	1.66	44.44	46.10	54.00	-7.90	AVG			P	

1000~6000MHz

Shenzhen General Testing & Inspection Technology Co., Ltd.

1-2/F., Building 2, Jiaquan Building, Guanlan High-Tech Park, Shenzhen, Guangdong, China

Tel.: (86)755-27521059

Fax.: (86)755-27521011

Http://www.sz.ctc.org.cn

Temperature:	24.2°C	Relative Humidity:	57%
Pressure:	101 Kpa	Test Mode:	Mode 6
Polarization:	Vertical	Test Power:	AC 120V/60Hz

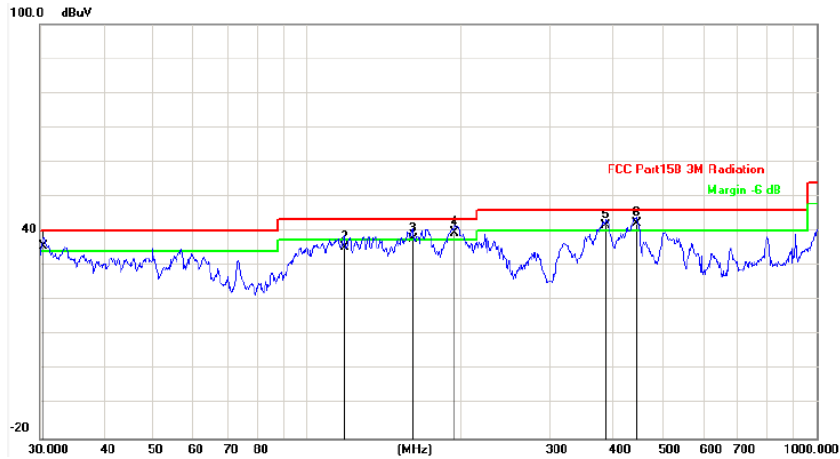

No.	Frequency (MHz)	Factor (dB)	Reading (dBuV)	Level (dBuV)	Limit (dBuV)	Margin (dB)	Detector	Height (cm)	Azimuth ( )	P/F	Remark
1	30.5306	-3.81	39.41	35.60	40.00	-4.40	QP			P	
2	118.6013	-13.44	48.94	35.50	43.50	-8.00	QP			P	
3	161.4740	-15.67	53.47	37.80	43.50	-5.70	QP			P	
4	195.1363	-13.59	53.09	39.50	43.50	-4.00	QP			P	
5	386.6338	-9.18	50.98	41.80	46.00	-4.20	QP			P	
6	443.2942	-8.14	50.34	42.20	46.00	-3.80	QP			P	

30~1000MHz

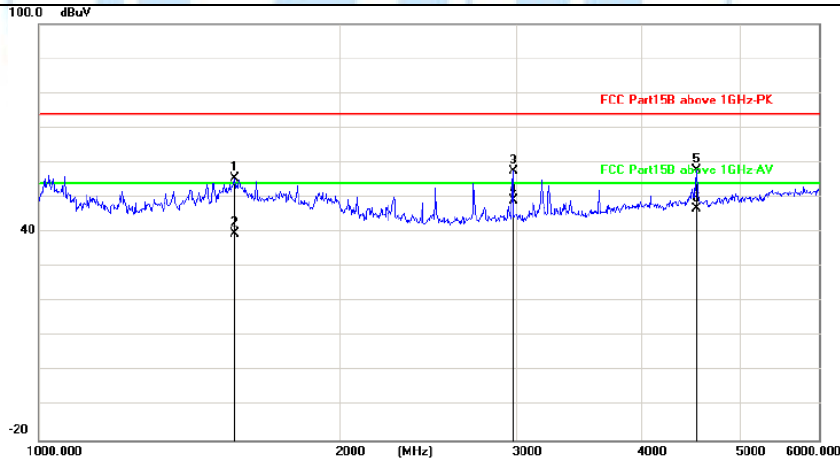

No.	Frequency (MHz)	Factor (dB)	Reading (dBuV)	Level (dBuV)	Limit (dBuV)	Margin (dB)	Detector	Height (cm)	Azimuth ( )	P/F	Remark
1	1567.891	-6.37	61.68	55.31	74.00	-18.69	peak			P	
2	1567.891	-6.37	45.97	39.60	54.00	-14.40	AVG			P	
3	2972.459	-2.73	60.26	57.53	74.00	-16.47	peak			P	
4	2972.459	-2.73	52.03	49.30	54.00	-4.70	AVG			P	
5	4528.783	1.66	56.29	57.95	74.00	-16.05	peak			P	
6	4528.783	1.66	45.24	46.90	54.00	-7.10	AVG			P	

1000~6000MHz

Shenzhen General Testing & Inspection Technology Co., Ltd.

1-2/F., Building 2, Jiaquan Building, Guanlan High-Tech Park, Shenzhen, Guangdong, China

Tel.: (86)755-27521059

Fax.: (86)755-27521011

Http://www.sz-cti.org.cn



中国国家认证认可监督管理委员会  
Certification and Accreditation Administration of the People's Republic of China

For anti-fake verification, please visit the official website of Certification and Accreditation Administration of the People's Republic of China : [yz.cncaic.cn](http://yz.cncaic.cn)



Temperature:	24.2°C	Relative Humidity:	57%
Pressure:	101 Kpa	Test Mode:	Mode 6
Polarization:	Horizontal	Test Power:	AC 120V/60Hz

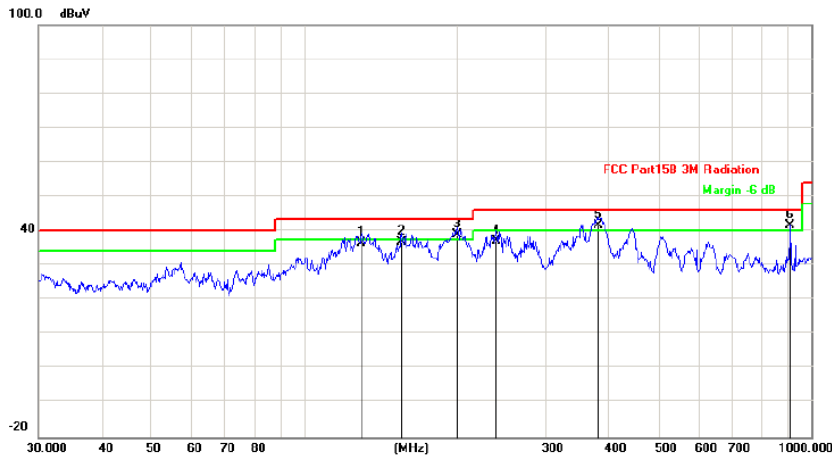

No.	Frequency (MHz)	Factor (dB)	Reading (dBuV)	Level (dBuV)	Limit (dBuV)	Margin (dB)	Detector	Height (cm)	Azimuth (°)	P/F	Remark
1	129.9225	-13.59	50.19	36.60	43.50	-6.90	QP			P	
2	155.9100	-15.36	52.26	36.90	43.50	-6.60	QP			P	
3	200.6879	-13.15	52.25	39.10	43.50	-4.40	QP			P	
4	239.9873	-13.48	50.68	37.20	46.00	-8.80	QP			P	
5	379.9141	-9.53	51.33	41.80	46.00	-4.20	QP			P	
6	909.6666	-0.93	42.53	41.60	46.00	-4.40	QP			P	

30~1000MHz

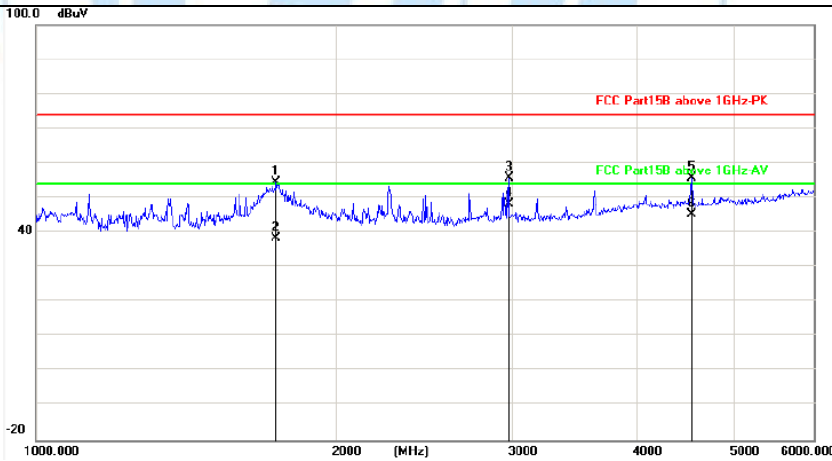

No.	Frequency (MHz)	Factor (dB)	Reading (dBuV)	Level (dBuV)	Limit (dBuV)	Margin (dB)	Detector	Height (cm)	Azimuth (°)	P/F	Remark
1	1739.597	-6.01	60.68	54.67	74.00	-19.33	peak			P	
2	1739.597	-6.01	44.41	38.40	54.00	-15.60	AVG			P	
3	2972.459	-2.73	58.53	55.80	74.00	-18.20	peak			P	
4	2972.459	-2.73	50.93	48.20	54.00	-5.80	AVG			P	
5	4528.783	1.66	54.18	55.84	74.00	-18.16	peak			P	
6	4528.783	1.66	43.44	45.10	54.00	-8.90	AVG			P	

1000~6000MHz

Shenzhen General Testing & Inspection Technology Co., Ltd.

1-2/F., Building 2, Jiaquan Building, Guanlan High-Tech Park, Shenzhen, Guangdong, China

Tel.: (86)755-27521059

Fax.: (86)755-27521011

Http://www.sz-ctc.org.cn



中国国家认证认可监督管理委员会  
Certification and Accreditation Administration of the People's Republic of China

For anti-fake verification, please visit the official website of Certification and Accreditation Administration of the People's Republic of China : [yz.cncaic.cn](http://yz.cncaic.cn)

## 5 EUT TEST PHOTO

### Conducted Measurement Photo



### Radiated Measurement Photo 30~1000MHz



**Radiated Measurement Photo 1000~6000MHz**





## 6 ATTACHMENT PHOTOGRAPHS OF EUT

### 1. Photo



### 2. Photo



### 3. Photo



### 4. Photo





5. Photo



6. Photo





7. Photo



8. Photo



9. Photo

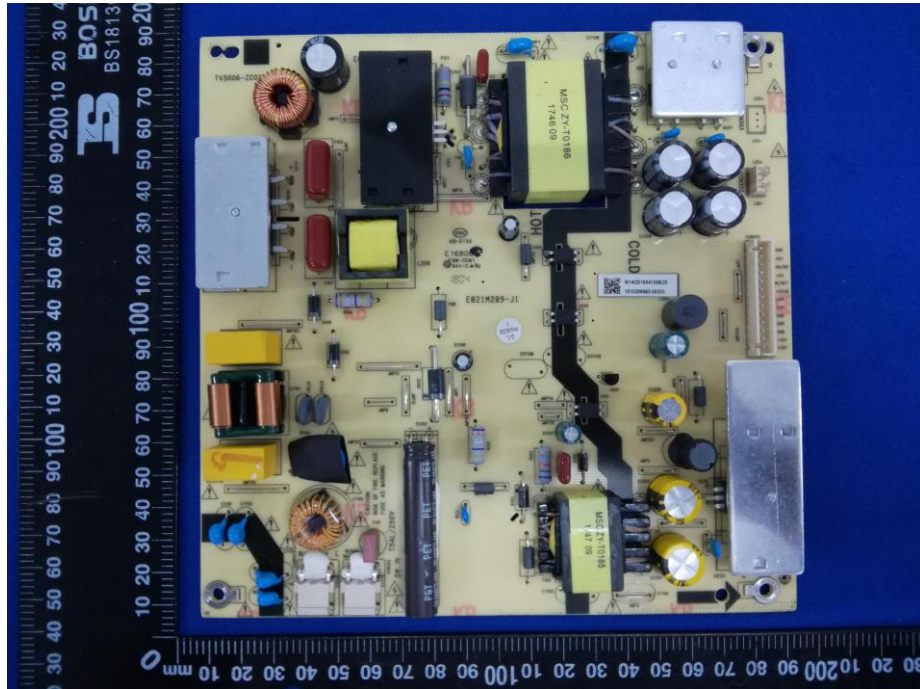

10. Photo

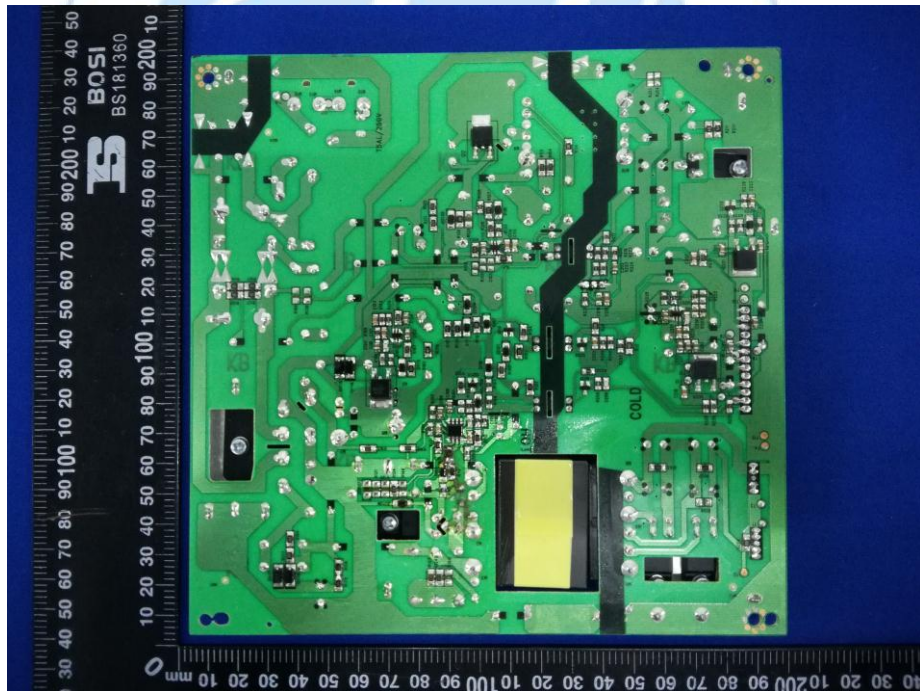



11. Photo

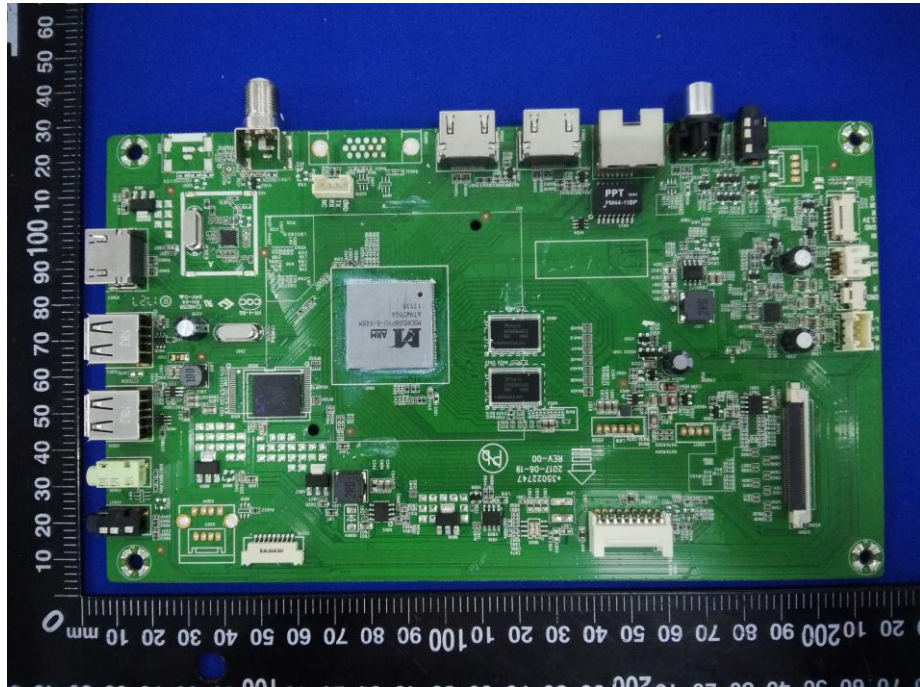

12. Photo

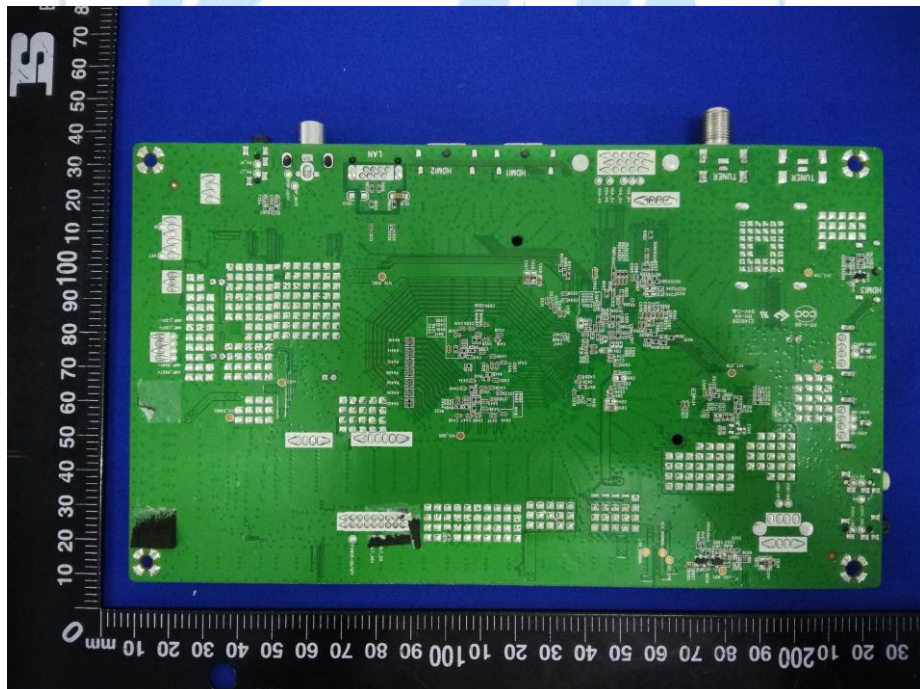

Shenzhen General Testing & Inspection Technology Co., Ltd.

1-2/F., Building 2, Jiaquan Building, Guanlan High-Tech Park, Shenzhen, Guangdong, China

Tel.: (86)755-27521059

Fax.: (86)755-27521011

Http://www.sz-ctc.org.cn

13. Photo

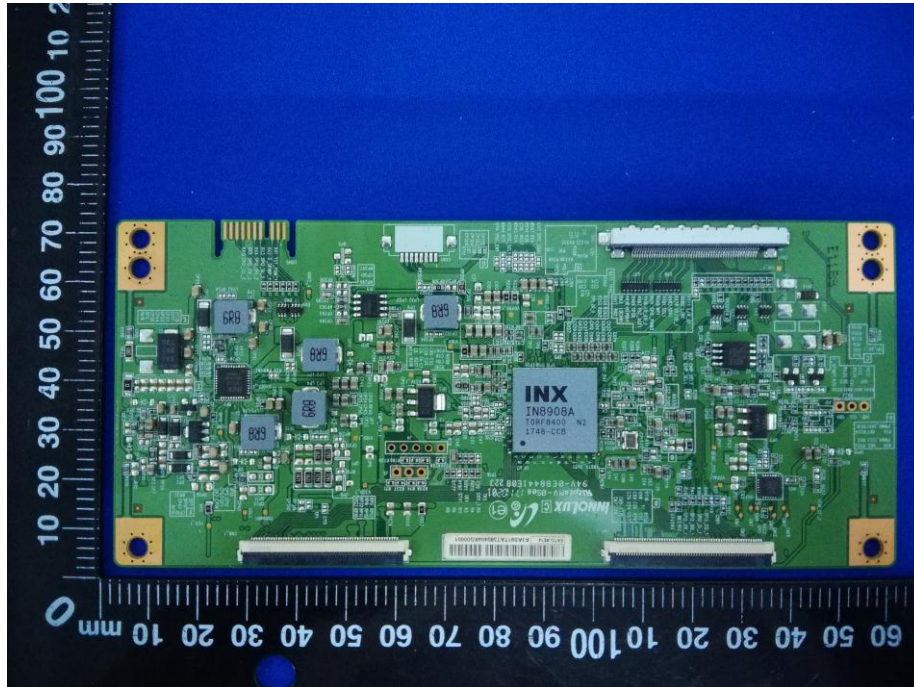

14. Photo

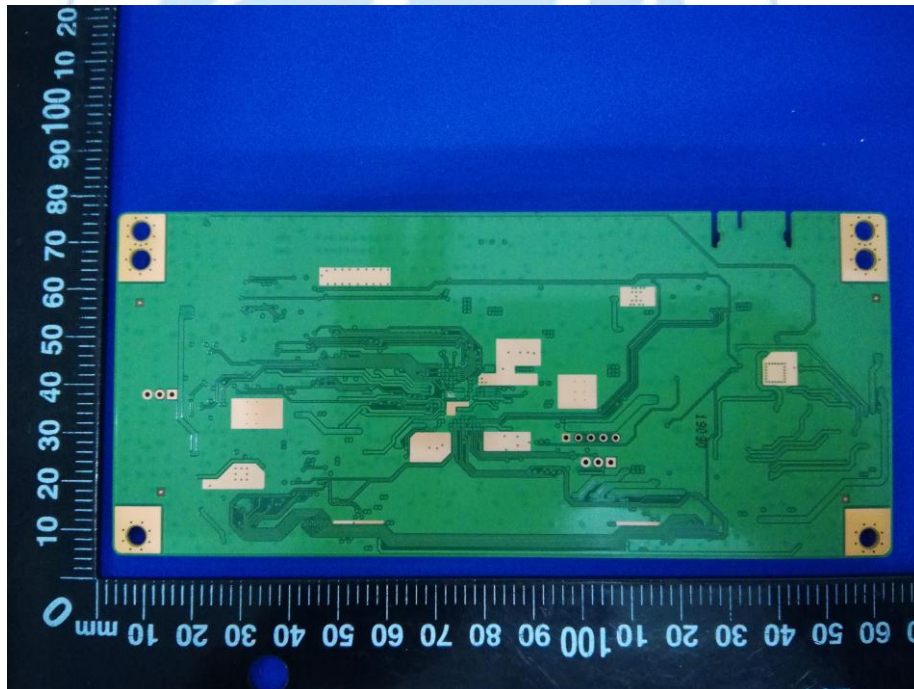





**==== End of Test Report ====**



---

Shenzhen General Testing & Inspection Technology Co., Ltd.

1-2/F., Building 2, Jiaquan Building, Guanlan High-Tech Park, Shenzhen, Guangdong, China

Tel.: (86)755-27521059

Fax.: (86)755-27521011 [Http://www.sz-ctc.org.cn](http://www.sz-ctc.org.cn)



中国国家认证认可监督管理委员会  
Certification and Accreditation Administration of the People's Republic of China

For anti-fake verification, please visit the official website of Certification and Accreditation Administration of the People's Republic of China : [yz.cncaic.cn](http://yz.cncaic.cn)