



# FCC Part 15C Test Report

## FCC ID: 2AHU8BF-1012

Product Name:	SPEAKER BOX
Trademark:	QFX
Model Name :	BF-1012 BF-1015, AV-1201, AV-1501, PBX-120, PBX-150, BF-2012, BF-2015, PBX-121, PBX-151
Prepared For :	Ningbo Polinata Electronics Co., Ltd.
Address :	Tiantongzhuang Village Wuxiang Town, Yinzhou District, Ningbo City, China
Prepared By :	Shenzhen BCTC Technology Co., Ltd.
Address :	No.101, Yousong Road, Longhua New District, Shenzhen, China
Test Date:	Jun. 29 – Jul. 10, 2016
Date of Report :	Jul. 13, 2016
Report No.:	BCTC-160608191E



**Table of Contents**

	<b>Page</b>
<b>1 . SUMMARY OF TEST RESULTS</b>	<b>5</b>
1.1 TEST FACILITY	5
1.2 MEASUREMENT UNCERTAINTY	5
<b>2 . GENERAL INFORMATION</b>	<b>6</b>
2.1 GENERAL DESCRIPTION OF EUT	6
2.2 DESCRIPTION OF TEST MODES	7
2.3 BLOCK DIGRAM SHOWING THE CONFIGURATION OF SYSTEM TESTED	8
2.4 DESCRIPTION OF SUPPORT UNITS(CONDUCTED MODE)	8
2.5 EQUIPMENTS LIST FOR ALL TEST ITEMS	9
<b>3 . EMC EMISSION TEST</b>	<b>10</b>
3.1 CONDUCTED EMISSION MEASUREMENT	10
3.1.1 POWER LINE CONDUCTED EMISSION LIMITS	10
3.1.2 TEST PROCEDURE	10
3.1.3 DEVIATION FROM TEST STANDARD	10
3.1.4 TEST SETUP	11
3.1.5 EUT OPERATING CONDITIONS	11
3.1.6 TEST RESULTS	11
3.2 RADIATED EMISSION MEASUREMENT	14
3.2.1 RADIATED EMISSION LIMITS	14
3.2.2 TEST PROCEDURE	15
3.2.3 DEVIATION FROM TEST STANDARD	15
3.2.4 TEST SETUP	15
3.2.5 EUT OPERATING CONDITIONS	16
3.2.6 TEST RESULTS (BETWEEN 9KHZ – 30 MHZ)	17
3.2.7 TEST RESULTS (BETWEEN 30MHZ – 1GHZ)	18
3.2.8 TEST RESULTS (1GHZ~25GHZ)	20
3.3 RADIATED BAND EMISSION MEASUREMENT	23
3.3.1 TEST REQUIREMENT:	23
3.3.2 TEST PROCEDURE	23
3.3.3 DEVIATION FROM TEST STANDARD	24
3.3.4 TEST SETUP	24
3.3.5 EUT OPERATING CONDITIONS	24
<b>4 . BANDWIDTH TEST</b>	<b>28</b>
4.1 APPLIED PROCEDURES / LIMIT	28



## Table of Contents

	<b>Page</b>
4.1.1 TEST PROCEDURE	28
4.1.2 DEVIATION FROM STANDARD	28
4.1.3 TEST SETUP	28
4.1.4 EUT OPERATION CONDITIONS	28
4.1.5 TEST RESULTS	29
<b>5 . ANTENNA REQUIREMENT</b>	<b>34</b>
5.1 STANDARD REQUIREMENT	34
5.2 EUT ANTENNA	34
<b>6 . TEST SEUUP PHOTO</b>	<b>35</b>
<b>7 . EUT PHOTO</b>	<b>37</b>



## 1. SUMMARY OF TEST RESULTS

Test procedures according to the technical standards:

FCC Part15 (15.249) , Subpart C			
Standard Section	Test Item	Judgment	Remark
15.207	Conducted Emission	PASS	
15.249	Radiated Spurious Emission	PASS	
15.249	Bandwidth	PASS	
15.205	Band Edge Emission	PASS	
15.203	Antenna Requirement	PASS	

### NOTE:

(1) "N/A" denotes test is not applicable in this Test Report

### 1.1 TEST FACILITY

Shenzhen BCTC Technology Co., Ltd.

Add. : No.101,Yousong Road,Longhua New District, Shenzhen,China

FCC Registered No.: 187086

### 1.2 MEASUREMENT UNCERTAINTY

The reported uncertainty of measurement  $y \pm U$  , where expended uncertainty  $U$  is based on a standard uncertainty multiplied by a coverage factor of  $k=2$  , providing a level of confidence of approximately **95** %.

No.	Item	Uncertainty
1	Conducted Emission Test	$\pm 1.38\text{dB}$
2	RF power,conducted	$\pm 0.16\text{dB}$
3	Spurious emissions,conducted	$\pm 0.21\text{dB}$
4	All emissions,radiated(<1G)	$\pm 4.68\text{dB}$
5	All emissions,radiated(>1G)	$\pm 4.89\text{dB}$
6	Temperature	$\pm 0.5^{\circ}\text{C}$
7	Humidity	$\pm 2\%$



## 2. GENERAL INFORMATION

### 2.1 GENERAL DESCRIPTION OF EUT

Equipment	SPEAKER BOX	
Trade Name	QFX	
Model Name	BF-1012 BF-1015, AV-1201, AV-1501, PBX-120, PBX-150, BF-2012, BF-2015, PBX-121, PBX-151	
Model Difference	All the models are the same circuit and RF module, except the model names and outlook color.	
Product Description	The EUT is a SPEAKER BOX	
	Operation Frequency:	2402~2480 MHz
	Modulation Type:	GFSK, PI/4 DPSK, 8DPSK
	Bit Rate of Transmitter	1/2/3Mbps
	Number Of Channel	79 CH
	Antenna type:	PCB antenna
	Antenna Gain (dBi)	0dBi
	Based on the application, features, or specification exhibited in User's Manual, the EUT is considered as an ITE/Computing Device. More details of EUT technical specification, please refer to the User's Manual.	
Channel List	Please refer to the Note 2.	
Power	AC 120V/60Hz	
hardware version	--	
Software version	--	
Serial number	--	
Connecting I/O Port(s)	Please refer to the User's Manual	

Note:

1. For a more detailed features description, please refer to the manufacturer's specifications or the User's Manual.



2.

Channel List					
Channel	Frequency (MHz)	Channel	Frequency (MHz)	Channel	Frequency (MHz)
00	2402	27	2429	54	2456
01	2403	28	2430	55	2457
02	2404	29	2431	56	2458
~	~	~	~	~	~
08	2410	35	2437	62	2464
09	2411	36	2438	63	2465
10	2412	37	2439	64	2466
11	2413	38	2440	65	2467
12	2414	39	2441	66	2468
13	2415	40	2442	67	2469
~	~	~	~	~	~
14	2416	41	2443	68	2470
22	2424	49	2451	76	2478
23	2425	50	2452	77	2479
24	2426	51	2453	78	2480
25	2427	52	2454		
26	2428	53	2455		

**2.2 DESCRIPTION OF TEST MODES**

To investigate the maximum EMI emission characteristics generates from EUT, the test system was pre-scanning tested base on the consideration of following EUT operation mode or test configuration mode which possible have effect on EMI emission level. Each of these EUT operation mode(s) or test configuration mode(s) mentioned above was evaluated respectively.

Pretest Mode	Description	
Mode 1	CH00	GFSK,PI/4 DPSK,8DPSK
Mode 2	CH39	
Mode 3	CH78	
Mode 4	Link Mode	
For Conducted & Radiated Emission		
Final Test Mode	Description	
Mode 1	CH00	GFSK,PI/4 DPSK,8DPSK
Mode 2	CH39	
Mode 3	CH78	
Mode 4	Link Mode	

Note:

- (1) The measurements are performed at the highest, middle, lowest available channels.
- (2) The measurements are performed at all Bit Rate of Transmitter, the worst data was reported



### 2.3 BLOCK DIGRAM SHOWING THE CONFIGURATION OF SYSTEM TESTED

Emission Test

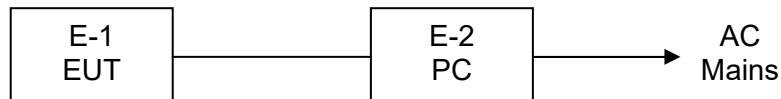

### 2.4 DESCRIPTION OF SUPPORT UNITS(CONDUCTED MODE)

The EUT has been tested as an independent unit together with other necessary accessories or support units. The following support units or accessories were used to form a representative test configuration during the tests.

Item	Equipment	Mfr/Brand	Model/Type No.	Series No.	Note
E-1	SPEAKER BOX	N/A	BF-1012	N/A	EUT

Item	Shielded Type	Ferrite Core	Length	Note

Note:

- (1) The support equipment was authorized by Declaration of Confirmation.
- (2) For detachable type I/O cable should be specified the length in cm in 『Length』 column.





## 2.5 EQUIPMENTS LIST FOR ALL TEST ITEMS

### Radiation Test equipment

Item	Kind of Equipment	Manufacturer	Type No.	Serial No.	Last calibration	Calibrated until
1	Spectrum Analyzer	Agilent	E4407B	MY45109572	2015.08.25	2016.08.24
2	Test Receiver	R&S	ESPI	101396	2015.08.25	2016.08.24
3	Bilog Antenna	SCHWARZBECK	VULB9160	VULB9160-3369	2015.08.25	2016.08.24
4	50Ω Coaxial Switch	Anritsu	MP59B	6200264416	2015.08.25	2016.08.24
5	Spectrum Analyzer	Agilent	N9020A	MY5051041	2015.08.25	2016.08.24
6	Horn Antenna	SCHWARZBECK	9120D	9120D-1275	2015.08.25	2016.08.24
7	Horn Ant	Schwarzbeck	BBHA 9170	9170-181	2015.08.25	2016.08.24
8	Amplifier	SCHWARZBECK	BBV9718	9718-270	2015.08.25	2016.08.24
9	Amplifier	SCHWARZBECK	BBV9743	9743-119	2015.08.25	2016.08.24
10	Loop Antenna	ARA	PLBF-101230/B	1029	2015.08.28	2016.08.28
11	Power Meter	R&S	NRVS	100696	2015.08.28	2016.08.28
12	Power Sensor	R&S	URV5-Z4	0395.1619.05	2015.08.28	2016.08.28
13	RF cables	R&S	N/A	N/A	2015.08.28	2016.08.28

### Conduction Test equipment

Item	Kind of Equipment	Manufacturer	Type No.	Serial No.	Last calibration	Calibrated until
1	Test Receiver	R&S	ESCI	1166.5950K03-101165-ha	2015.08.24	2016.08.23
2	LISN	R&S	NSLK8126	8126466	2015.08.24	2016.08.23
3	LISN	R&S	NSLK8126	8126487	2015.08.24	2016.08.23
4	50Ω Coaxial Switch	Anritsu	MP59B	6200264417	2015.08.24	2016.08.23
5	RF cables	R&S	R204	R20X	2015.08.24	2016.08.23



### 3. EMC EMISSION TEST

#### 3.1 CONDUCTED EMISSION MEASUREMENT

##### 3.1.1 POWER LINE CONDUCTED EMISSION Limits (Frequency Range 150KHz-30MHz)

FREQUENCY (MHz)	Class A (dBuV)		Class B (dBuV)		Standard
	Quasi-peak	Average	Quasi-peak	Average	
0.15 -0.5	79.00	66.00	66 - 56 *	56 - 46 *	FCC
0.50 -5.0	73.00	60.00	56.00	46.00	FCC
5.0 -30.0	73.00	60.00	60.00	50.00	FCC

Note:

- (1) The tighter limit applies at the band edges.
- (2) The limit of " \* " marked band means the limitation decreases linearly with the logarithm of the frequency in the range.

The following table is the setting of the receiver

Receiver Parameters	Setting
Attenuation	10 dB
Start Frequency	0.15 MHz
Stop Frequency	30 MHz
IF Bandwidth	9 kHz

##### 3.1.2 TEST PROCEDURE

- a. The EUT was placed 0.1 meters from the horizontal ground plane with EUT being connected to the power mains through a line impedance stabilization network (LISN). All other support equipments powered from additional LISN(s). The LISN provide 50 Ohm/ 50uH of coupling impedance for the measuring instrument.
- b. Interconnecting cables that hang closer than 40 cm to the ground plane shall be folded back and forth in the center forming a bundle 30 to 40 cm long.
- c. I/O cables that are not connected to a peripheral shall be bundled in the center. The end of the cable may be terminated, if required, using the correct terminating impedance. The overall length shall not exceed 1 m.
- d. LISN at least 80 cm from nearest part of EUT chassis.
- e. For the actual test configuration, please refer to the related Item –EUT Test Photos.

##### 3.1.3 DEVIATION FROM TEST STANDARD

No deviation

### 3.1.4 TEST SETUP

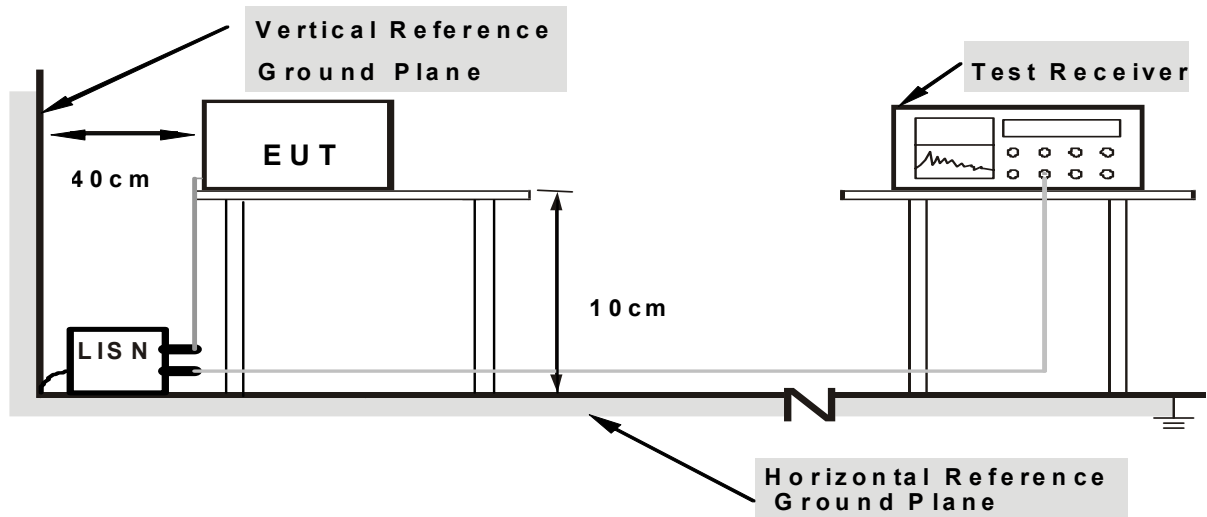

Note: 1.Support units were connected to second LISN.

2.Both of LISNs (AMN) are 80 cm from EUT and at least 80 from other units and other metal planes

### 3.1.5 EUT OPERATING CONDITIONS

The EUT was configured for testing in a typical fashion (as a customer would normally use it). The EUT has been programmed to continuously transmit during test. This operating condition was tested and used to collect the included data.

### 3.1.6 TEST RESULTS



Temperature :	25 °C	Relative Humidity :	54%
Pressure :	1010hPa	Phase :	L
Test Voltage :	AC 120V/60Hz	Test Mode :	Mode 4

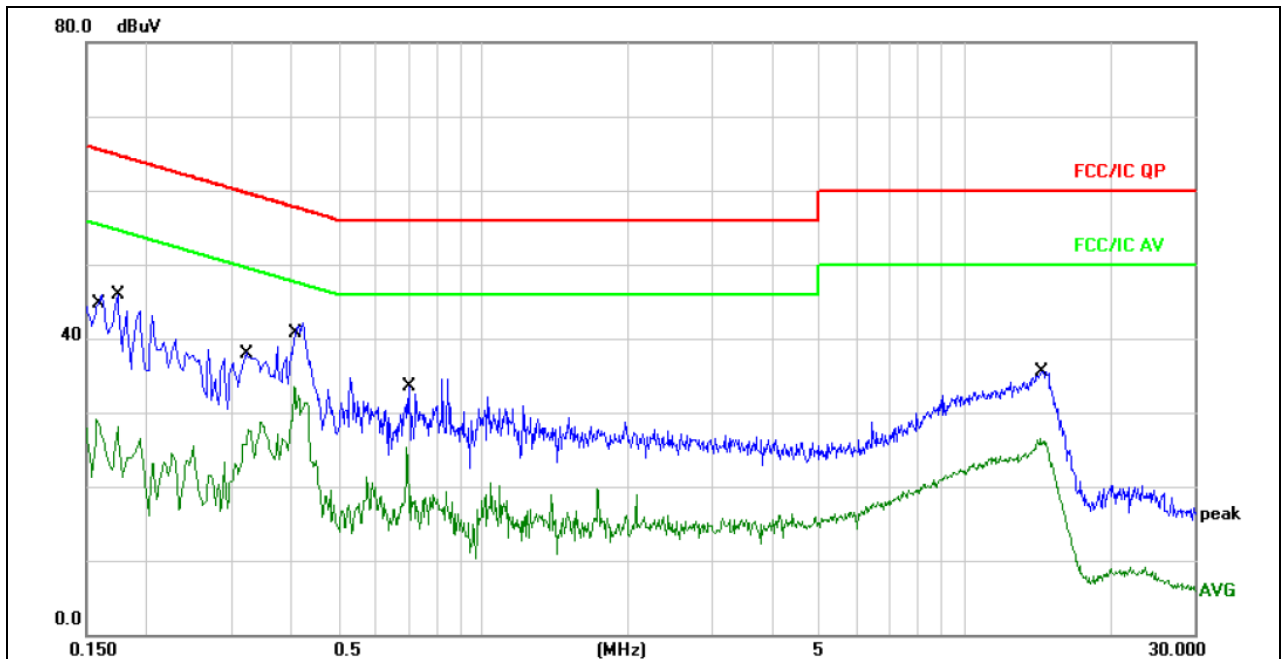

Remark:

1. All readings are Quasi-Peak and Average values.
2. Factor = Insertion Loss + Cable Loss.

No.	Mk.	Freq. MHz	Reading Level dBuV	Correct Factor dB	Measure- ment dBuV	Limit dBuV	Over dB	Detector	Comment
1		0.1580	35.77	10.05	45.82	65.56	-19.74	QP	
2		0.1580	19.00	10.05	29.05	55.56	-26.51	AVG	
3		0.1740	35.80	10.06	45.86	64.76	-18.90	QP	
4		0.1740	17.97	10.06	28.03	54.76	-26.73	AVG	
5		0.3268	27.32	10.10	37.42	59.53	-22.11	QP	
6		0.3268	18.59	10.10	28.69	49.53	-20.84	AVG	
7		0.4060	31.90	10.11	42.01	57.73	-15.72	QP	
8	*	0.4060	23.32	10.11	33.43	47.73	-14.30	AVG	
9		0.6940	23.46	10.13	33.59	56.00	-22.41	QP	
10		0.6940	15.11	10.13	25.24	46.00	-20.76	AVG	
11		14.4340	25.39	10.14	35.53	60.00	-24.47	QP	
12		14.4340	16.31	10.14	26.45	50.00	-23.55	AVG	



Temperature :	25 °C	Relative Humidity :	54%
Pressure :	1010hPa	Phase :	N
Test Voltage :	AC 120V/60Hz	Test Mode :	Mode 4

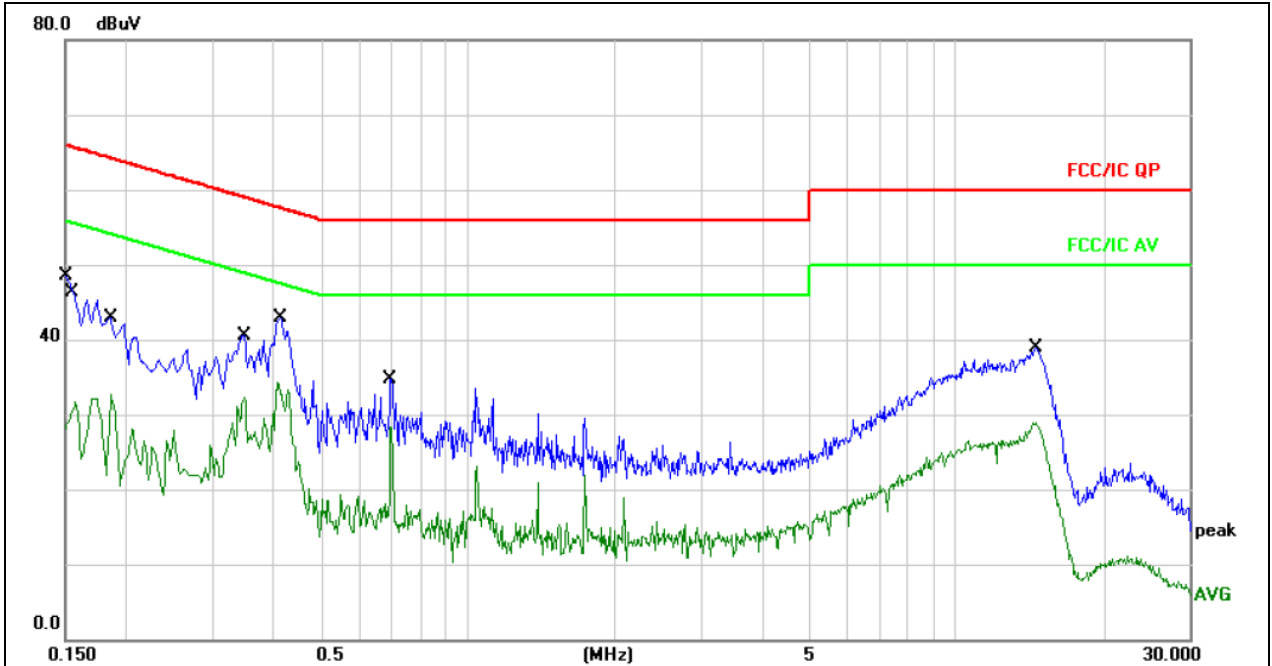

Remark:

1. All readings are Quasi-Peak and Average values.
2. Factor = Insertion Loss + Cable Loss.

No.	Mk.	Freq.	Reading Level	Correct Factor	Measurement	Limit	Over	Detector	Comment
		MHz	dBuV	dB	dBuV	dBuV	dB		
1		0.1500	38.51	10.05	48.56	65.99	-17.43	QP	
2		0.1580	21.66	10.05	31.71	55.56	-23.85	AVG	
3		0.1860	32.93	10.06	42.99	64.21	-21.22	QP	
4		0.1860	22.66	10.06	32.72	54.21	-21.49	AVG	
5		0.3500	30.41	10.10	40.51	58.96	-18.45	QP	
6		0.3500	22.18	10.10	32.28	48.96	-16.68	AVG	
7		0.4100	32.89	10.11	43.00	57.65	-14.65	QP	
8	*	0.4100	24.24	10.11	34.35	47.65	-13.30	AVG	
9		0.6940	24.64	10.13	34.77	56.00	-21.23	QP	
10		0.6940	18.17	10.13	28.30	46.00	-17.70	AVG	
11		14.5380	28.73	10.15	38.88	60.00	-21.12	QP	
12		14.5380	18.80	10.15	28.95	50.00	-21.05	AVG	



### 3.2 RADIATED EMISSION MEASUREMENT

#### 3.2.1 RADIATED EMISSION LIMITS (Frequency Range 9kHz-1000MHz)

In case the emission fall within the restricted band specified on 15.205(a), then the 15.209(a) limit in the table below has to be followed.

Frequencies (MHz)	Field Strength (micorvolts/meter)	Measurement Distance (meters)
0.009~0.490	2400/F(KHz)	300
0.490~1.705	24000/F(KHz)	30
1.705~30.0	30	30
30~88	100	3
88~216	150	3
216~960	200	3
Above 960	500	3

#### LIMITS OF RADIATED EMISSION MEASUREMENT (Above 1000MHz)

FREQUENCY (MHz)	Class B (dBuV/m) (at 3M)	
	PEAK	AVERAGE
Above 1000	74	54

Notes:

- (1) The limit for radiated test was performed according to FCC PART 15C.
- (2) The tighter limit applies at the band edges.
- (3) Emission level (dBuV/m)=20log Emission level (uV/m).

Spectrum Parameter	Setting
Attenuation	Auto
Start Frequency	1000 MHz
Stop Frequency	25GHz
RB / VB (emission in restricted band)	1 MHz / 1 MHz for Peak, 1 MHz / 10Hz for Average

Receiver Parameter	Setting
Attenuation	Auto
Start ~ Stop Frequency	9kHz~150kHz / RB 200Hz for QP
Start ~ Stop Frequency	150kHz~30MHz / RB 9kHz for QP
Start ~ Stop Frequency	30MHz~1000MHz / RB 120kHz for QP

### 3.2.2 TEST PROCEDURE

Below 1GHz test procedure as below:

- The EUT was placed on the top of a rotating table 0.1 meters above the ground at a 3 meter semi-anechoic chamber. The table was rotated 360 degrees to determine the position of the highest radiation.
- The EUT was set 3 meters away from the interference-receiving antenna, which was mounted on the top of a variable-height antenna tower.
- The antenna height is varied from one meter to four meters above the ground to determine the maximum value of the field strength. Both horizontal and vertical polarizations of the antenna are set to make the measurement.
- For each suspected emission, the EUT was arranged to its worst case and then the antenna was tuned to heights from 1 meter to 4 meters (for the test frequency of below 30MHz, the antenna was tuned to heights 1 meter) and the rotatable table was turned from 0 degrees to 360 degrees to find the maximum reading.
- The test-receiver system was set to Peak Detect Function and Specified Bandwidth with Maximum Hold Mode.
- If the emission level of the EUT in peak mode was 10dB lower than the limit specified, then testing could be stopped and the peak values of the EUT would be reported. Otherwise the emissions that did not have 10dB margin would be re-tested one by one using peak, quasi-peak or average method as specified and then reported in a data sheet.

Above 1GHz test procedure as below:

- Different between above is the test site, change from Semi-Anechoic Chamber to fully Anechoic Chamber and change from table 0.1 metre to 0.1 metre (Above 18GHz the distance is 1 meter and table is 0.1 metre).
- Test the EUT in the lowest channel, the middle channel, the Highest channel

Note:

Both horizontal and vertical antenna polarities were tested and performed pretest to three orthogonal axis. The worst case emissions were reported

### 3.2.3 DEVIATION FROM TEST STANDARD

No deviation

### 3.2.4 TEST SETUP

(A) Radiated Emission Test-Up Frequency Below 30MHz

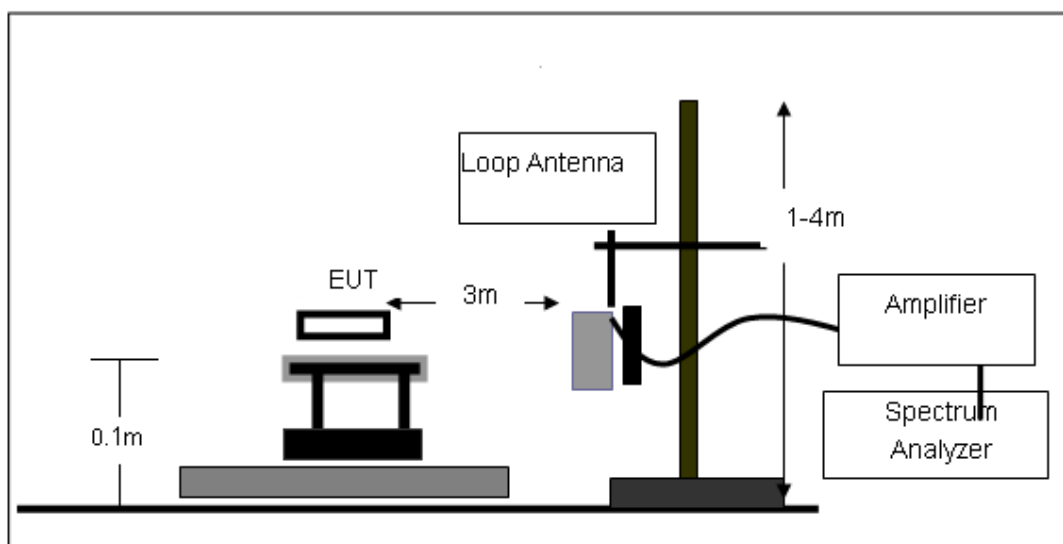

## (B) Radiated Emission Test-Up Frequency 30MHz~1GHz

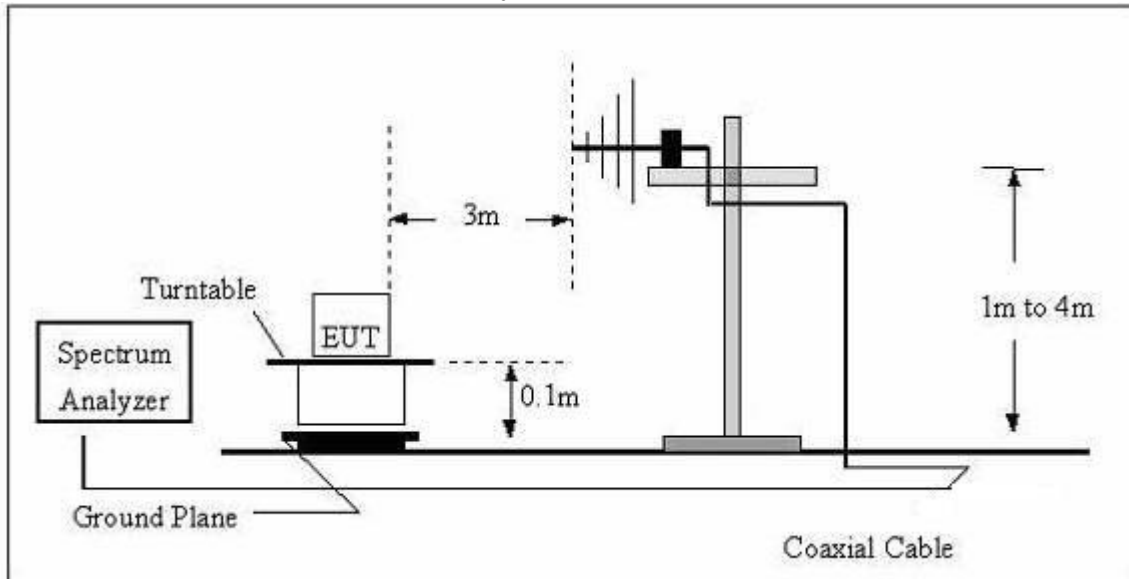

## (C) Radiated Emission Test-Up Frequency Above 1GHz

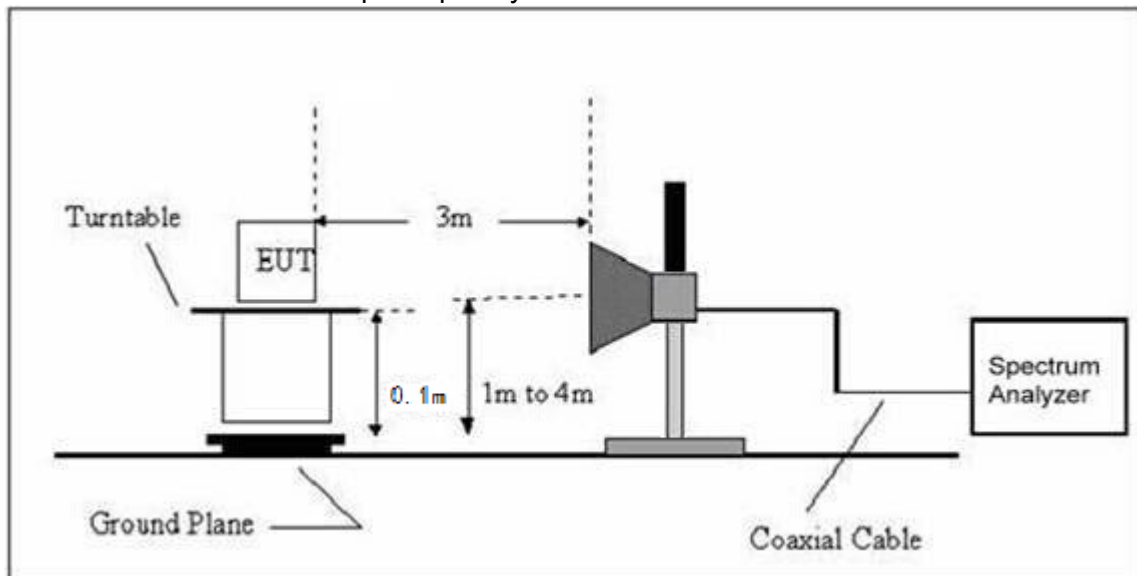

### 3.2.5 EUT OPERATING CONDITIONS

The EUT tested system was configured as the statements of 2.3 Unless otherwise a special operating condition is specified in the follows during the testing.



**3.2.6 TEST RESULTS (BETWEEN 9KHZ – 30 MHZ)**

Temperature:	20℃	Relative Humidity:	48%
Pressure:	1010 hPa	Test Voltage :	AC 120V/60Hz
Test Mode :	Mode 4	Polarization :	--

Freq. (MHz)	Reading (dBuV/m)	Limit (dBuV/m)	Margin (dB)	State P/F
--	--	--	--	PASS
--	--	--	--	PASS

**NOTE:**

The amplitude of spurious emissions which are attenuated by more than 20dB below the permissible value has no need to be reported.

Distance extrapolation factor =  $40 \log(\text{specific distance}/\text{test distance})$ (dB);

Limit line = specific limits(dBuv) + distance extrapolation factor.



**3.2.7 TEST RESULTS (BETWEEN 30MHZ – 1GHZ)**

Temperature :	26°C	Relative Humidity :	54%
Pressure :	1010 hPa	Polarization :	Horizontal
Test Voltage :	AC 120V/60Hz		
Test Mode :	Mode 4		

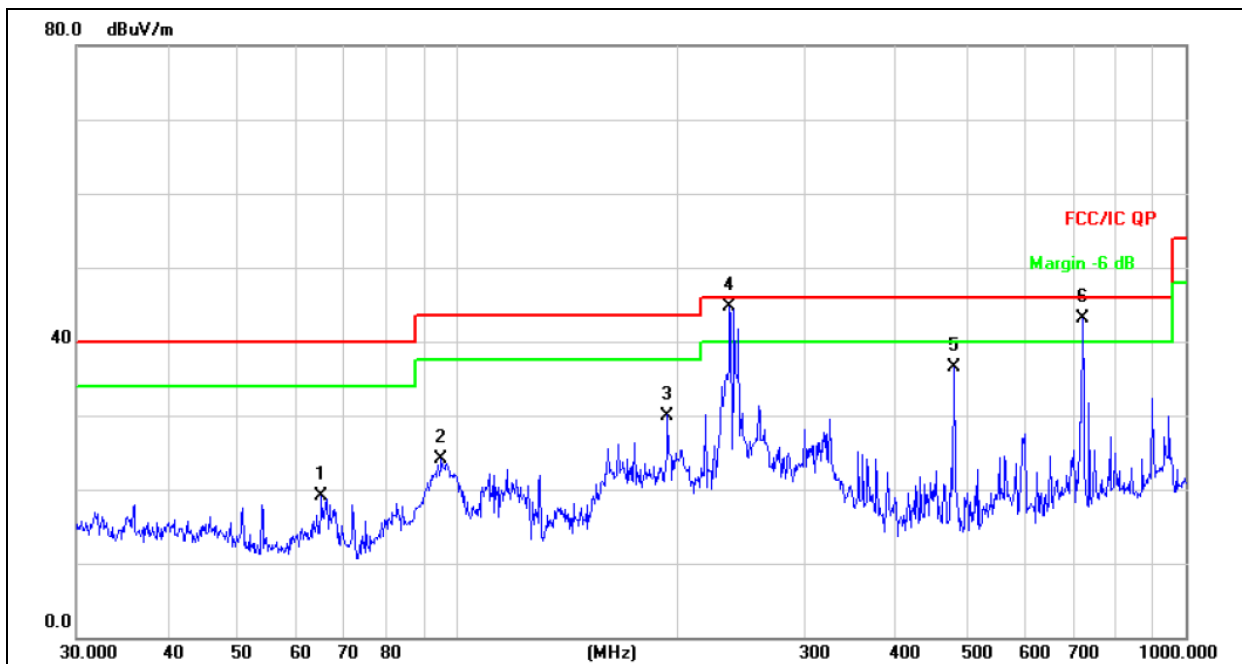

Remark:  
 Factor = Antenna Factor + Cable Loss – Pre-amplifier.  
 All interfaces was connected, and BT TX mode was link.

No. Mk.	Freq. MHz	Reading Level dBuV	Correct Factor dB/m	Measure- ment dBuV/m	Limit dBuV/m	Over dB	Antenna Height cm	Table Degree degree	Detector	Comment
1	65.1145	31.62	-12.57	19.05	40.00	-20.95			QP	
2	95.0930	41.07	-17.01	24.06	43.50	-19.44			QP	
3	194.4534	45.86	-15.86	30.00	43.50	-13.50			QP	
4	* 236.6447	59.42	-14.68	44.74	46.00	-1.26			QP	
5	480.5276	45.01	-8.42	36.59	46.00	-9.41			QP	
6	! 721.7259	46.98	-3.93	43.05	46.00	-2.95			QP	



Temperature :	26°C	Relative Humidity :	54%
Pressure :	1010 hPa	Polarization :	Vertical
Test Voltage :	AC 120V/60Hz		
Test Mode :	Mode 4		

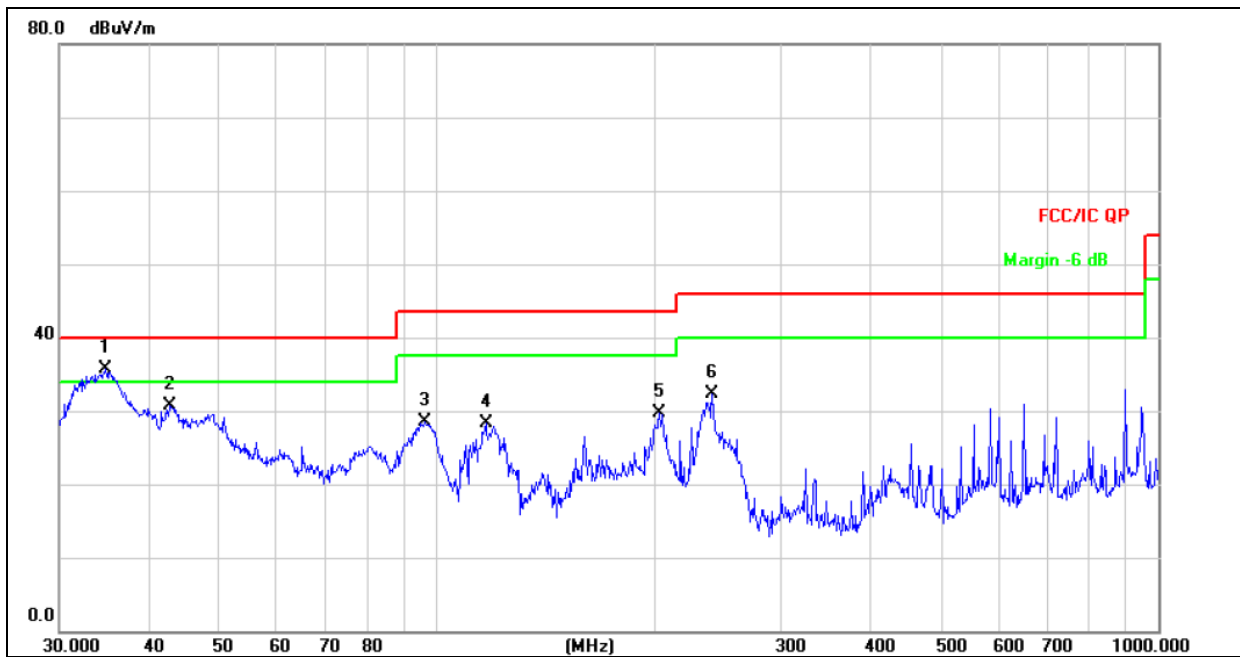

Remark:  
 Factor = Antenna Factor + Cable Loss – Pre-amplifier.  
 All interfaces was connected, and BT TX mode was link.

No.	Mk.	Freq.	Reading Level	Correct Factor	Measurement	Limit	Over	Antenna Height	Table Degree	
		MHz	dBuV	dB/m	dBuV/m	dBuV/m	dB	cm	degree	Comment
1	*	34.7602	44.11	-8.49	35.62	40.00	-4.38	QP		
2		42.6000	39.84	-9.16	30.68	40.00	-9.32	QP		
3		96.4362	45.42	-16.87	28.55	43.50	-14.95	QP		
4		116.9495	43.21	-15.00	28.21	43.50	-15.29	QP		
5		203.5228	45.75	-16.10	29.65	43.50	-13.85	QP		
6		240.8304	46.82	-14.47	32.35	46.00	-13.65	QP		



**3.2.8 TEST RESULTS (1GHZ~25GHZ)**

GFSK

Polar (H/V)	Frequency	Meter Reading	Factor	Emission Level	Limits	Margin	Detector Type
	(MHz)	(dBuV)	(dB)	(dBuV/m)	(dBuV/m)	(dB)	
<b>operation frequency:2402</b>							
V	2402.00	89.22	13.85	103.07	114.00	-10.93	PK
V	2402.00	73.75	13.85	87.60	94.00	-6.40	AV
V	4804.00	39.88	19.34	59.22	74.00	-14.78	PK
V	4804.00	26.06	19.34	45.40	54.00	-8.60	AV
V	16130.00	30.32	21.89	52.21	74.00	-21.79	PK
H	2402.00	89.19	13.85	103.04	114.00	-10.96	PK
H	2402.00	74.36	13.85	88.21	94.00	-5.79	AV
H	4804.00	40.72	19.34	60.06	74.00	-13.94	PK
H	4804.00	25.95	19.34	45.29	54.00	-8.71	AV
H	16130.00	30.06	21.89	51.95	74.00	-22.05	PK
<b>operation frequency:2441</b>							
V	2441.00	89.74	13.94	103.68	114.00	-10.32	PK
V	2441.00	73.89	13.94	87.83	94.00	-6.17	AV
V	4882.00	40.82	19.42	60.24	74.00	-13.76	PK
V	4882.00	26.10	19.42	45.52	54.00	-8.48	AV
V	16130.00	28.55	21.89	50.44	74.00	-23.56	PK
H	2441.00	89.76	13.94	103.70	114.00	-10.30	PK
H	2441.00	74.78	13.94	88.72	94.00	-5.28	AV
H	4882.00	41.90	19.42	61.32	74.00	-12.68	PK
H	4882.00	26.84	19.42	46.26	54.00	-7.74	AV
H	16130.00	30.23	21.89	52.12	74.00	-21.88	PK
<b>operation frequency:2480</b>							
V	2480.00	89.79	14.02	103.81	114.00	-10.19	PK
V	2480.00	73.99	14.02	88.01	94.00	-5.99	AV
V	4960.00	41.63	19.51	61.14	74.00	-12.86	PK
V	4960.00	26.38	19.51	45.89	54.00	-8.11	AV
V	16130.00	30.45	21.89	52.34	74.00	-21.66	PK
H	2480.00	89.82	14.02	103.84	114.00	-10.16	PK
H	2480.00	73.84	14.02	87.86	94.00	-6.14	AV
H	4960.00	41.85	19.51	61.36	74.00	-12.64	PK
H	4960.00	26.41	19.51	45.92	54.00	-8.08	AV
H	16130.00	30.78	21.89	52.67	74.00	-21.33	PK

**Remark:**

1. Emission Level = Meter Reading + Factor, Margin= Emission Level - Limit
2. If peak below the average limit, the average emission was no test.
3. The amplitude of spurious emissions which are attenuated by more than 20dB below the permissible value has no need to be reported.



PI/4 DPSK

Polar (H/V)	Frequency	Meter Reading	Factor	Emission Level	Limits	Margin	Detector Type
	(MHz)	(dBuV)	(dB)	(dBuV/m)	(dBuV/m)	(dB)	
<b>operation frequency:2402</b>							
V	2402.00	89.15	13.85	103.00	114.00	-11.00	PK
V	2402.00	73.69	13.85	87.54	94.00	-6.46	AV
V	4804.00	39.84	19.34	59.18	74.00	-14.82	PK
V	4804.00	26.04	19.34	45.38	54.00	-8.62	AV
V	16130.00	30.29	21.89	52.18	74.00	-21.82	PK
H	2402.00	89.12	13.85	102.97	114.00	-11.03	PK
H	2402.00	74.30	13.85	88.15	94.00	-5.85	AV
H	4804.00	40.68	19.34	60.02	74.00	-13.98	PK
H	4804.00	25.93	19.34	45.27	54.00	-8.73	AV
H	16130.00	30.03	21.89	51.92	74.00	-22.08	PK
<b>operation frequency:2441</b>							
V	2441.00	89.67	13.94	103.61	114.00	-10.39	PK
V	2441.00	73.83	13.94	87.77	94.00	-6.23	AV
V	4882.00	40.78	19.42	60.20	74.00	-13.80	PK
V	4882.00	26.08	19.42	45.50	54.00	-8.50	AV
V	16130.00	28.53	21.89	50.42	74.00	-23.58	PK
H	2441.00	89.69	13.94	103.63	114.00	-10.37	PK
H	2441.00	74.72	13.94	88.66	94.00	-5.34	AV
H	4882.00	41.87	19.42	61.29	74.00	-12.71	PK
H	4882.00	26.82	19.42	46.24	54.00	-7.76	AV
H	16130.00	30.20	21.89	52.09	74.00	-21.91	PK
<b>operation frequency:2480</b>							
V	2480.00	89.72	14.02	103.74	114.00	-10.26	PK
V	2480.00	73.93	14.02	87.95	94.00	-6.05	AV
V	4960.00	41.60	19.51	61.11	74.00	-12.89	PK
V	4960.00	26.36	19.51	45.87	54.00	-8.13	AV
V	16130.00	30.42	21.89	52.31	74.00	-21.69	PK
H	2480.00	89.75	14.02	103.77	114.00	-10.23	PK
H	2480.00	73.78	14.02	87.80	94.00	-6.20	AV
H	4960.00	41.82	19.51	61.33	74.00	-12.67	PK
H	4960.00	26.39	19.51	45.90	54.00	-8.10	AV
H	16130.00	30.75	21.89	52.64	74.00	-21.36	PK
<b>Remark:</b>							
1. Emission Level = Meter Reading + Factor, Margin= Emission Level - Limit							
2. If peak below the average limit, the average emission was no test.							
3. The amplitude of spurious emissions which are attenuated by more than 20dB below the permissible value has no need to be reported.							



8DPSK

Polar (H/V)	Frequency	Meter Reading	Factor	Emission Level	Limits	Margin	Detector Type
	(MHz)	(dBuV)	(dB)	(dBuV/m)	(dBuV/m)	(dB)	
<b>operation frequency:2402</b>							
V	2402.00	88.70	13.85	102.55	114.00	-11.45	PK
V	2402.00	73.32	13.85	87.17	94.00	-6.83	AV
V	4804.00	39.65	19.34	58.99	74.00	-15.01	PK
V	4804.00	25.91	19.34	45.25	54.00	-8.75	AV
V	16130.00	30.14	21.89	52.03	74.00	-21.97	PK
H	2402.00	88.67	13.85	102.52	114.00	-11.48	PK
H	2402.00	73.93	13.85	87.78	94.00	-6.22	AV
H	4804.00	40.48	19.34	59.82	74.00	-14.18	PK
H	4804.00	25.80	19.34	45.14	54.00	-8.86	AV
H	16130.00	29.88	21.89	51.77	74.00	-22.23	PK
<b>operation frequency:2441</b>							
V	2441.00	89.21	13.94	103.15	114.00	-10.85	PK
V	2441.00	73.46	13.94	87.40	94.00	-6.60	AV
V	4882.00	40.58	19.42	60.00	74.00	-14.00	PK
V	4882.00	25.95	19.42	45.37	54.00	-8.63	AV
V	16130.00	28.39	21.89	50.28	74.00	-23.72	PK
H	2441.00	89.23	13.94	103.17	114.00	-10.83	PK
H	2441.00	74.35	13.94	88.29	94.00	-5.71	AV
H	4882.00	41.66	19.42	61.08	74.00	-12.92	PK
H	4882.00	26.69	19.42	46.11	54.00	-7.89	AV
H	16130.00	30.05	21.89	51.94	74.00	-22.06	PK
<b>operation frequency:2480</b>							
V	2480.00	89.26	14.02	103.28	114.00	-10.72	PK
V	2480.00	73.56	14.02	87.58	94.00	-6.42	AV
V	4960.00	41.39	19.51	60.90	74.00	-13.10	PK
V	4960.00	26.23	19.51	45.74	54.00	-8.26	AV
V	16130.00	30.27	21.89	52.16	74.00	-21.84	PK
H	2480.00	89.29	14.02	103.31	114.00	-10.69	PK
H	2480.00	73.41	14.02	87.43	94.00	-6.57	AV
H	4960.00	41.61	19.51	61.12	74.00	-12.88	PK
H	4960.00	26.26	19.51	45.77	54.00	-8.23	AV
H	16130.00	30.60	21.89	52.49	74.00	-21.51	PK
<p><b>Remark:</b></p> <ol style="list-style-type: none"> <li>1. Emission Level = Meter Reading + Factor, Margin= Emission Level - Limit</li> <li>2. If peak below the average limit, the average emission was no test.</li> <li>3. The amplitude of spurious emissions which are attenuated by more than 20dB below the permissible value has no need to be reported.</li> </ol>							



### 3.3 RADIATED BAND EMISSION MEASUREMENT

#### 3.3.1 TEST REQUIREMENT:

FCC Part15 C Section 15.209 and 15.205

#### LIMITS OF RADIATED EMISSION MEASUREMENT (Above 1000MHz)

FREQUENCY (MHz)	Class B (dBuV/m) (at 3M)	
	PEAK	AVERAGE
Above 1000	74	54

Notes:

- (1) The limit for radiated test was performed according to FCC PART 15C.
- (2) The tighter limit applies at the band edges.
- (3) Emission level (dBuV/m)=20log Emission level (uV/m).

Spectrum Parameter	Setting
Attenuation	Auto
Start Frequency	2300MHz
Stop Frequency	2520
RB / VB (emission in restricted band)	1 MHz / 1 MHz for Peak, 1 MHz / 10Hz for Average

#### 3.3.2 TEST PROCEDURE

Above 1GHz test procedure as below:

- a. 1. The EUT was placed on the top of a rotating table 1.5 meters above the ground at a 3 meter camber. The table was rotated 360 degrees to determine the position of the highest radiation.
- b. The EUT was set 3 meters away from the interference-receiving antenna, which was mounted on the top of a variable-height antenna tower.
- c. The antenna height is varied from one meter to four meters above the ground to determine the maximum value of the field strength. Both horizontal and vertical polarizations of the antenna are set to make the measurement.
- d. For each suspected emission, the EUT was arranged to its worst case and then the antenna was tuned to heights from 1 meter to 4 meters and the rota table was turned from 0 degrees to 360 degrees to find the maximum reading.
- e. The test-receiver system was set to Peak Detect Function and Specified Bandwidth with Maximum Hold Mode.
- f. If the emission level of the EUT in peak mode was 10dB lower than the limit specified, then testing could be stopped and the peak values of the EUT would be reported. Otherwise the emissions that did not have 10dB margin would be re-tested one by one using peak, quasi-peak or average method as specified and then reported in a data sheet.
- g. Test the EUT in the lowest channel,the Highest channel

Note:

Both horizontal and vertical antenna polarities were tested and performed pretest to three orthogonal axis. The worst case emissions were reported

### 3.3.3 DEVIATION FROM TEST STANDARD

No deviation

### 3.3.4 TEST SETUP

Radiated Emission Test-Up Frequency Above 1GHz

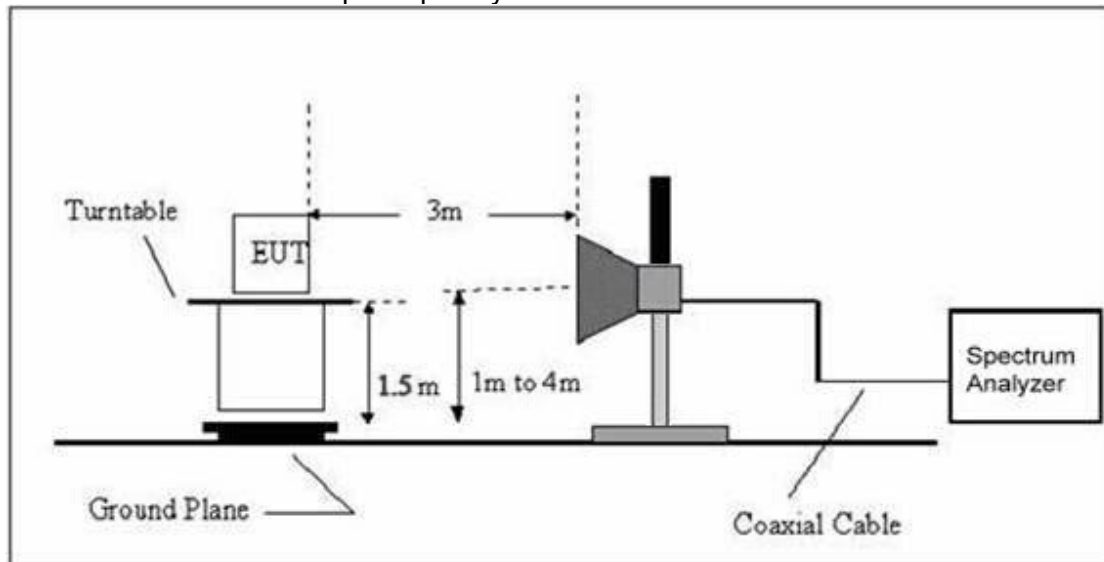

### 3.3.5 EUT OPERATING CONDITIONS

The EUT tested system was configured as the statements of 2.3 Unless otherwise a special operating condition is specified in the follows during the testing.





### 3.3.6 TEST RESULT

GFSK

Polar (H/V)	Frequency	Meter Reading	Factor	Emission Level	Limits	Margin	Detector Type
	(MHz)	(dBuV)	(dB)	(dBuV/m)	(dBuV/m)	(dB)	
<b>operation frequency:2402</b>							
V	2390.00	37.67	13.83	51.50	74.00	-22.50	PK
V	2390.00	26.18	13.83	40.01	54.00	-13.99	AV
V	2400.00	37.88	13.85	51.73	74.00	-22.27	PK
V	2400.00	25.75	13.85	39.60	54.00	-14.40	AV
H	2390.00	37.97	13.83	51.80	74.00	-22.20	PK
H	2390.00	26.21	13.83	40.04	54.00	-13.96	AV
H	2400.00	37.83	13.85	51.68	74.00	-22.32	PK
H	2400.00	26.15	13.85	40.00	54.00	-14.00	AV

Polar (H/V)	Frequency	Meter Reading	Factor	Emission Level	Limits	Margin	Detector Type
	(MHz)	(dBuV)	(dB)	(dBuV/m)	(dBuV/m)	(dB)	
<b>operation frequency:2480</b>							
V	2483.50	37.88	14.02	51.90	74.00	-22.10	PK
V	2483.50	26.43	14.02	40.45	54.00	-13.55	AV
V	2500.00	37.82	14.06	51.88	74.00	-22.12	PK
V	2500.00	25.85	14.06	39.91	54.00	-14.09	AV
H	2483.50	38.01	14.02	52.03	74.00	-21.97	PK
H	2483.50	26.47	14.02	40.49	54.00	-13.51	AV
H	2500.00	37.62	14.06	51.68	74.00	-22.32	PK
H	2500.00	26.72	14.06	40.78	54.00	-13.22	AV

**Remark:**

1. Emission Level = Meter Reading + Factor, Margin= Emission Level - Limit
2. If peak below the average limit, the average emission was no test.
3. The amplitude of spurious emissions which are attenuated by more than 20dB below the permissible value has no need to be reported.



PI/4 DPSK

Polar (H/V)	Frequency	Meter Reading	Factor	Emission Level	Limits	Margin	Detector Type
	(MHz)	(dBuV)	(dB)	(dBuV/m)	(dBuV/m)	(dB)	
<b>operation frequency:2402</b>							
V	2390.00	37.55	13.83	51.38	74.00	-22.62	PK
V	2390.00	26.09	13.83	39.92	54.00	-14.08	AV
V	2400.00	37.76	13.85	51.61	74.00	-22.39	PK
V	2400.00	25.66	13.85	39.51	54.00	-14.49	AV
H	2390.00	37.85	13.83	51.68	74.00	-22.32	PK
H	2390.00	26.12	13.83	39.95	54.00	-14.05	AV
H	2400.00	37.71	13.85	51.56	74.00	-22.44	PK
H	2400.00	26.06	13.85	39.91	54.00	-14.09	AV

Polar (H/V)	Frequency	Meter Reading	Factor	Emission Level	Limits	Margin	Detector Type
	(MHz)	(dBuV)	(dB)	(dBuV/m)	(dBuV/m)	(dB)	
<b>operation frequency:2480</b>							
V	2483.50	37.76	14.02	51.78	74.00	-22.22	PK
V	2483.50	26.34	14.02	40.36	54.00	-13.64	AV
V	2500.00	37.70	14.06	51.76	74.00	-22.24	PK
V	2500.00	25.76	14.06	39.82	54.00	-14.18	AV
H	2483.50	37.89	14.02	51.91	74.00	-22.09	PK
H	2483.50	26.38	14.02	40.40	54.00	-13.60	AV
H	2500.00	37.50	14.06	51.56	74.00	-22.44	PK
H	2500.00	26.63	14.06	40.69	54.00	-13.31	AV

**Remark:**

1. Emission Level = Meter Reading + Factor, Margin= Emission Level - Limit
2. If peak below the average limit, the average emission was no test.
3. The amplitude of spurious emissions which are attenuated by more than 20dB below the permissible value has no need to be reported.



8DPSK

Polar (H/V)	Frequency	Meter Reading	Factor	Emission Level	Limits	Margin	Detector Type
	(MHz)	(dBuV)	(dB)	(dBuV/m)	(dBuV/m)	(dB)	
<b>operation frequency:2402</b>							
V	2390.00	37.49	13.83	51.32	74.00	-22.68	PK
V	2390.00	26.05	13.83	39.88	54.00	-14.12	AV
V	2400.00	37.70	13.85	51.55	74.00	-22.45	PK
V	2400.00	25.63	13.85	39.48	54.00	-14.52	AV
H	2390.00	37.79	13.83	51.62	74.00	-22.38	PK
H	2390.00	26.08	13.83	39.91	54.00	-14.09	AV
H	2400.00	37.65	13.85	51.50	74.00	-22.50	PK
H	2400.00	26.02	13.85	39.87	54.00	-14.13	AV

Polar (H/V)	Frequency	Meter Reading	Factor	Emission Level	Limits	Margin	Detector Type
	(MHz)	(dBuV)	(dB)	(dBuV/m)	(dBuV/m)	(dB)	
<b>operation frequency:2480</b>							
V	2483.50	37.70	14.02	51.72	74.00	-22.28	PK
V	2483.50	26.30	14.02	40.32	54.00	-13.68	AV
V	2500.00	37.64	14.06	51.70	74.00	-22.30	PK
V	2500.00	25.72	14.06	39.78	54.00	-14.22	AV
H	2483.50	37.83	14.02	51.85	74.00	-22.15	PK
H	2483.50	26.34	14.02	40.36	54.00	-13.64	AV
H	2500.00	37.44	14.06	51.50	74.00	-22.50	PK
H	2500.00	26.59	14.06	40.65	54.00	-13.35	AV

**Remark:**

1. Emission Level = Meter Reading + Factor, Margin= Emission Level - Limit
2. If peak below the average limit, the average emission was no test.
3. The amplitude of spurious emissions which are attenuated by more than 20dB below the permissible value has no need to be reported.



#### 4. BANDWIDTH TEST

##### 4.1 APPLIED PROCEDURES / LIMIT

FCC Part15 (15.249) , Subpart C				
Section	Test Item	Limit	Frequency Range (MHz)	Result
15.249	Bandwidth	(20dB bandwidth)	2400-2483.5	PASS

##### 4.1.1 TEST PROCEDURE

1. Set RBW = 100 kHz.
2. Set the video bandwidth (VBW)  $\geq 3 \times$  RBW.
3. Detector = Peak.
4. Trace mode = max hold.
5. Sweep = auto couple.
6. Allow the trace to stabilize.
7. Measure the maximum width of the emission that is constrained by the frequencies associated with the two outermost amplitude points (upper and lower frequencies) that are attenuated by 6 dB relative to the maximum level measured in the fundamental emission.

##### 4.1.2 DEVIATION FROM STANDARD

No deviation.

##### 4.1.3 TEST SETUP



##### 4.1.4 EUT OPERATION CONDITIONS

The EUT tested system was configured as the statements of 2.3 Unless otherwise a special operating condition is specified in the follows during the testing.



4.1.5 TEST RESULTS

Temperature :	25°C	Relative Humidity :	60%
Pressure :	1012 hPa	Test Voltage :	AC 120V/60Hz
Test Mode :	TX Mode /CH00, CH39, CH78		

	Frequency (MHz)	20dB bandwidth (MHz)	Result
GFSK	2402	0.942	Pass
	2441	0.943	Pass
	2480	0.947	Pass
PI/4 DPSK	2402	1.255	Pass
	2441	1.274	Pass
	2480	1.271	Pass
8DPSK	2402	1.275	Pass
	2441	1.248	Pass
	2480	1.273	Pass

GFSK

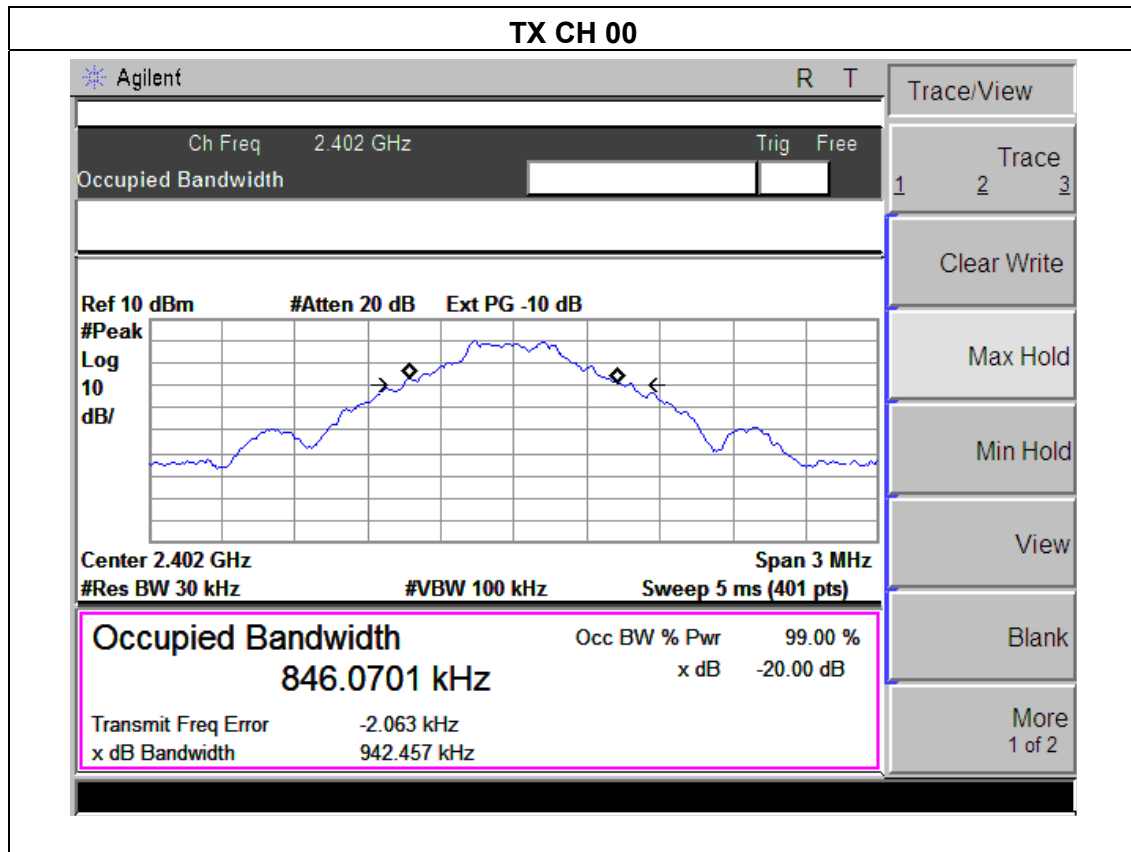

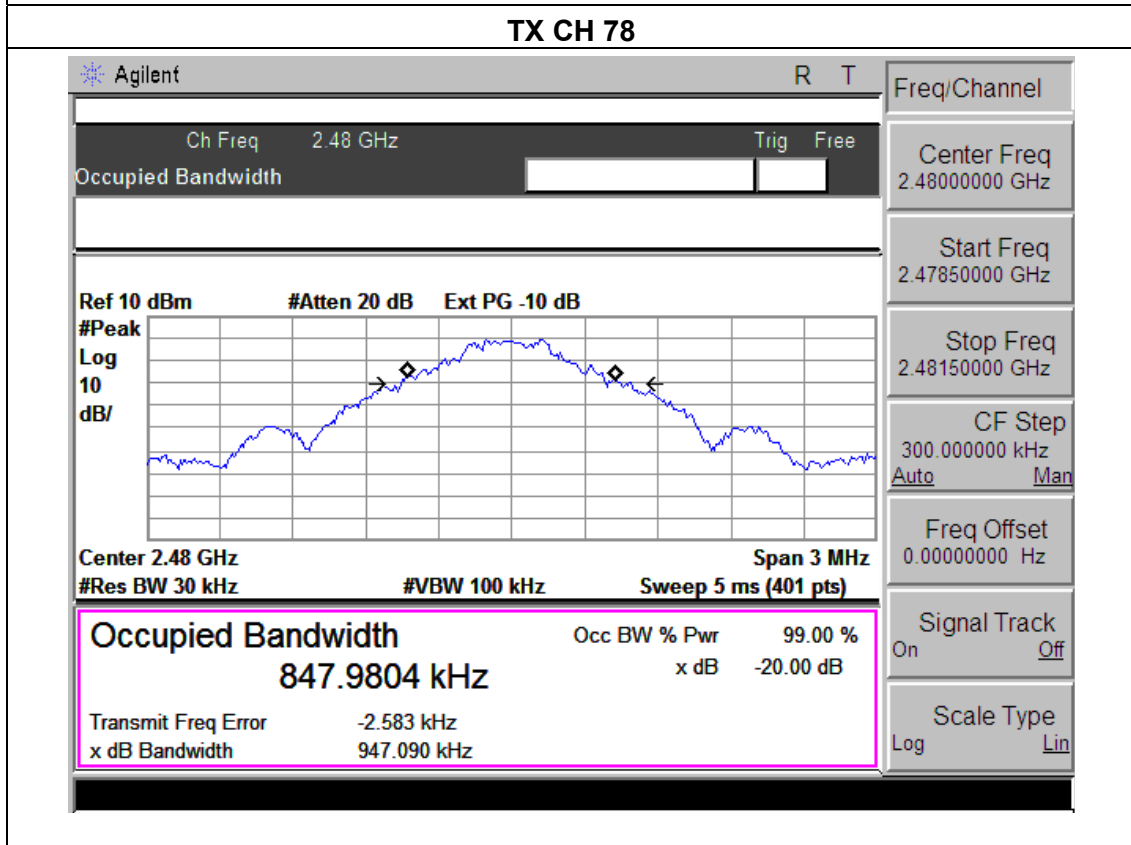
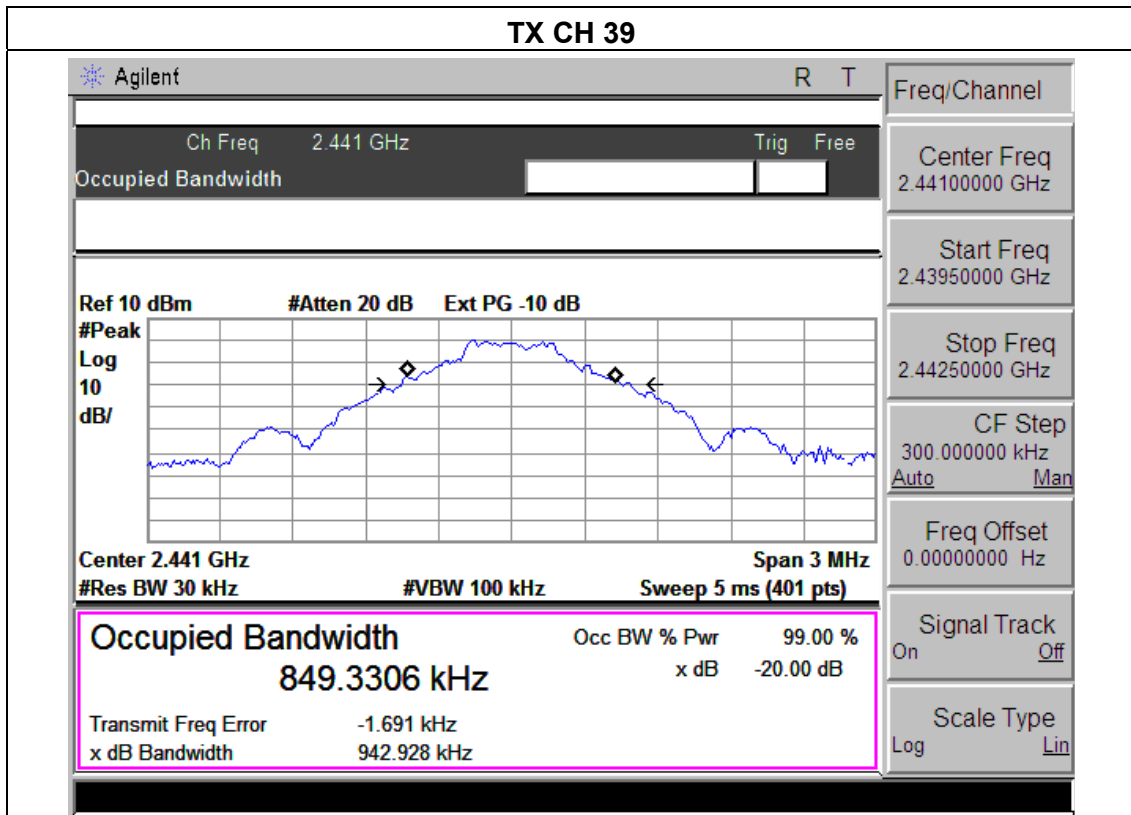



PI/4 DPSK

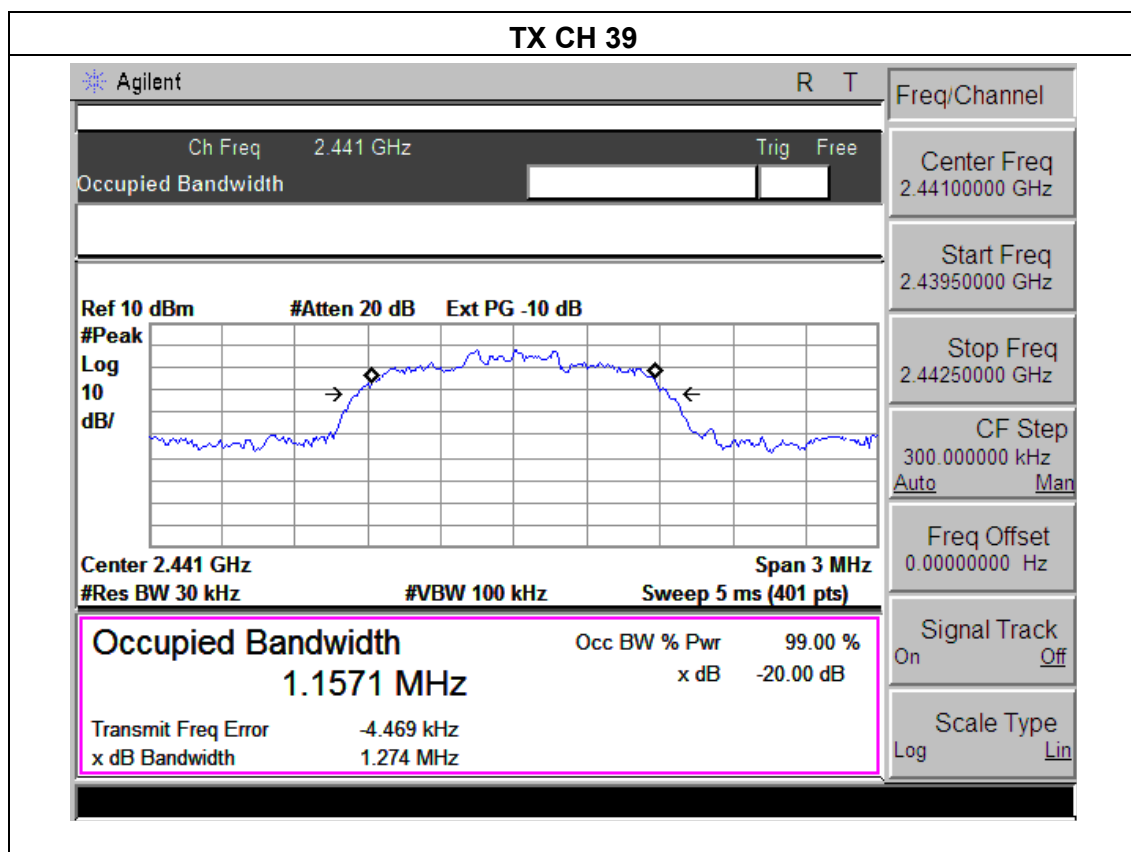
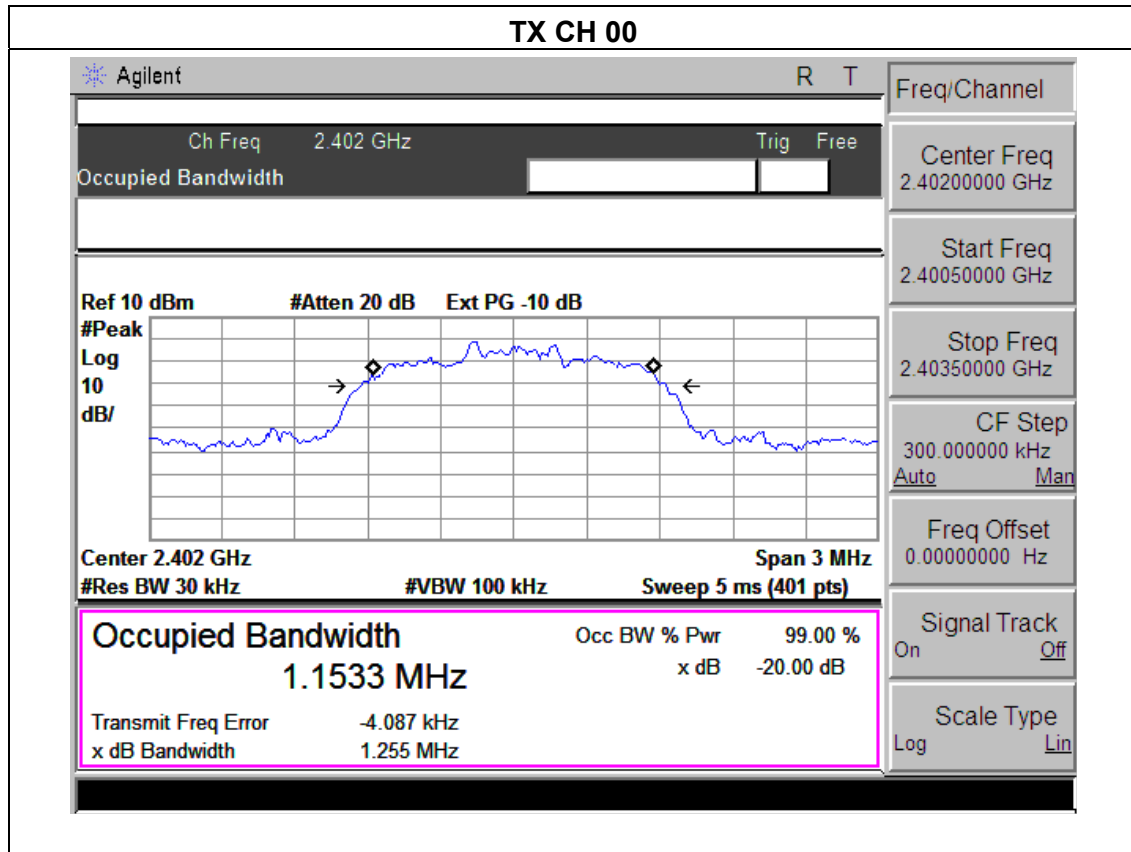

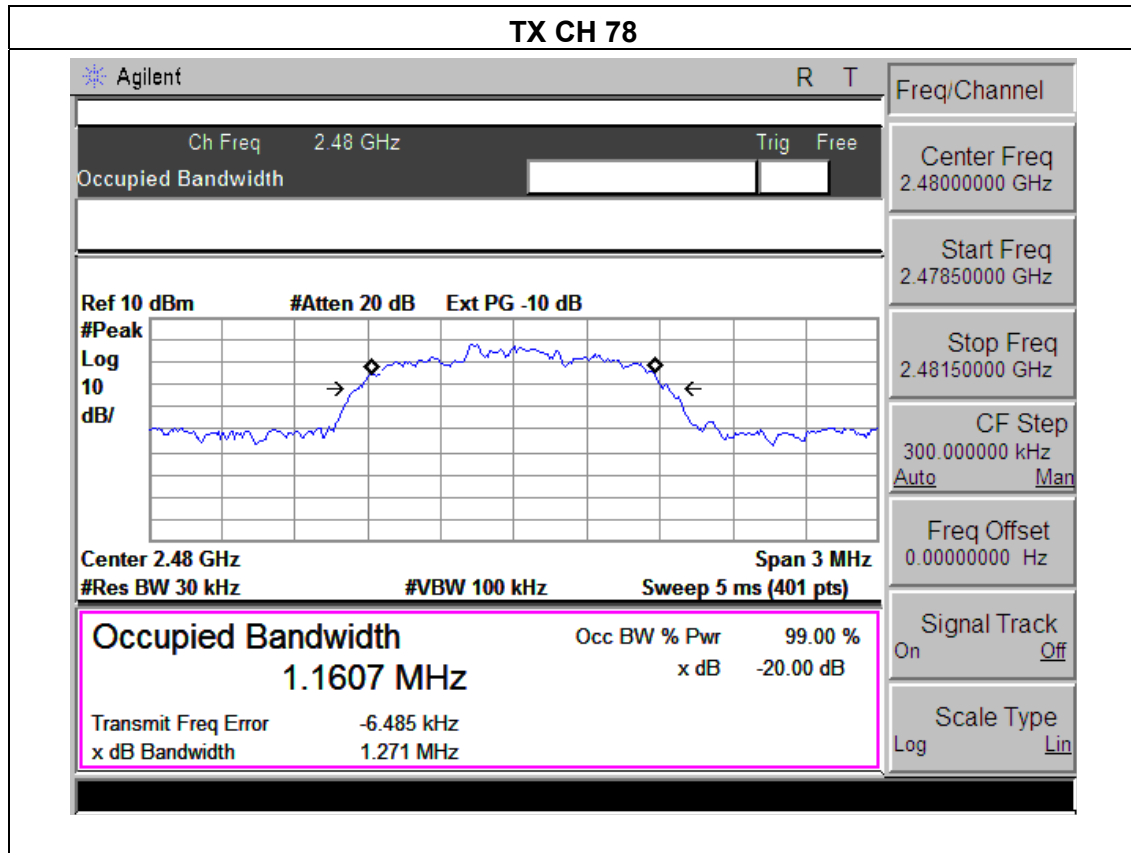

8DPSK

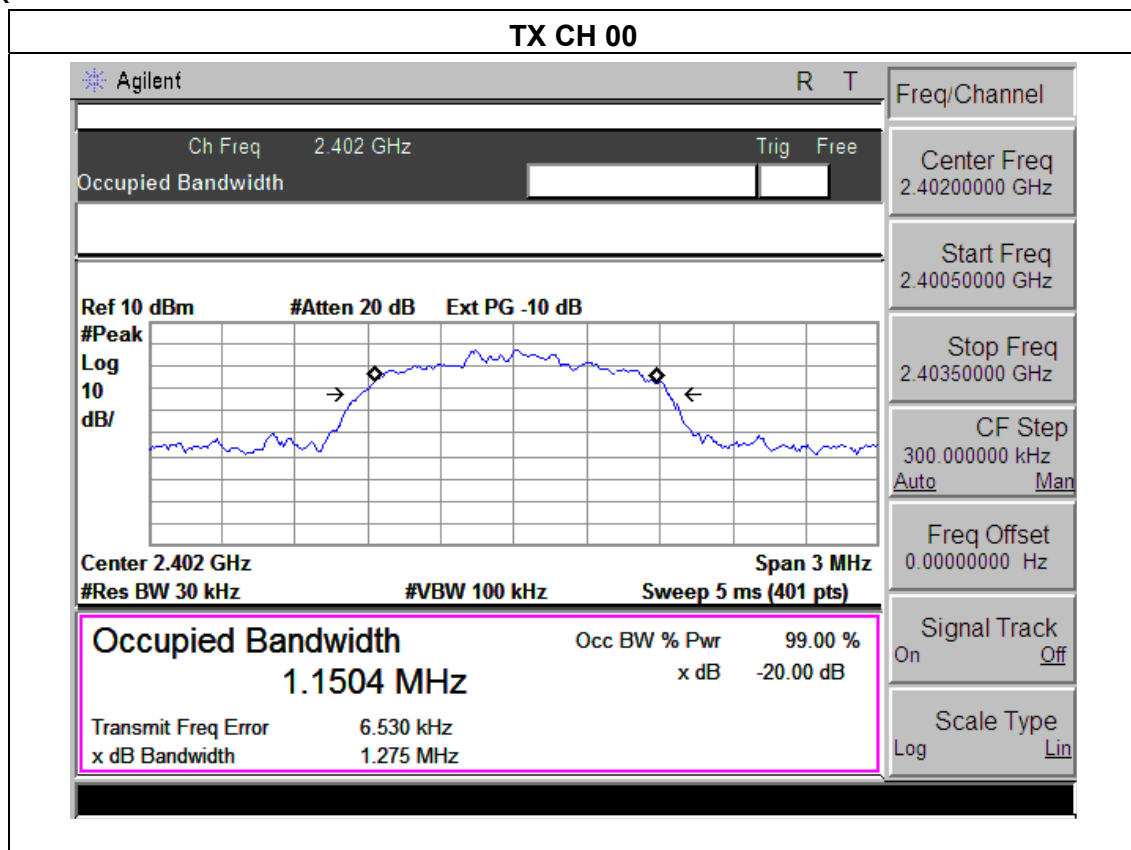



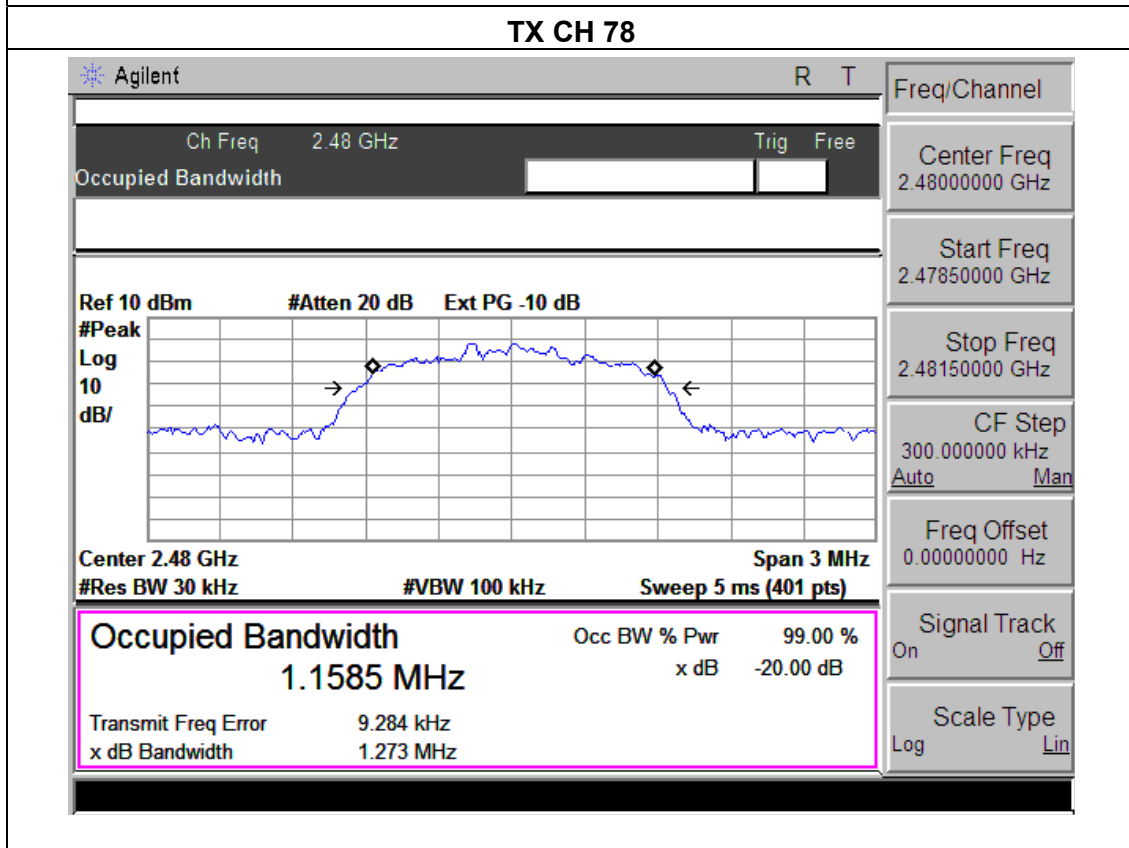
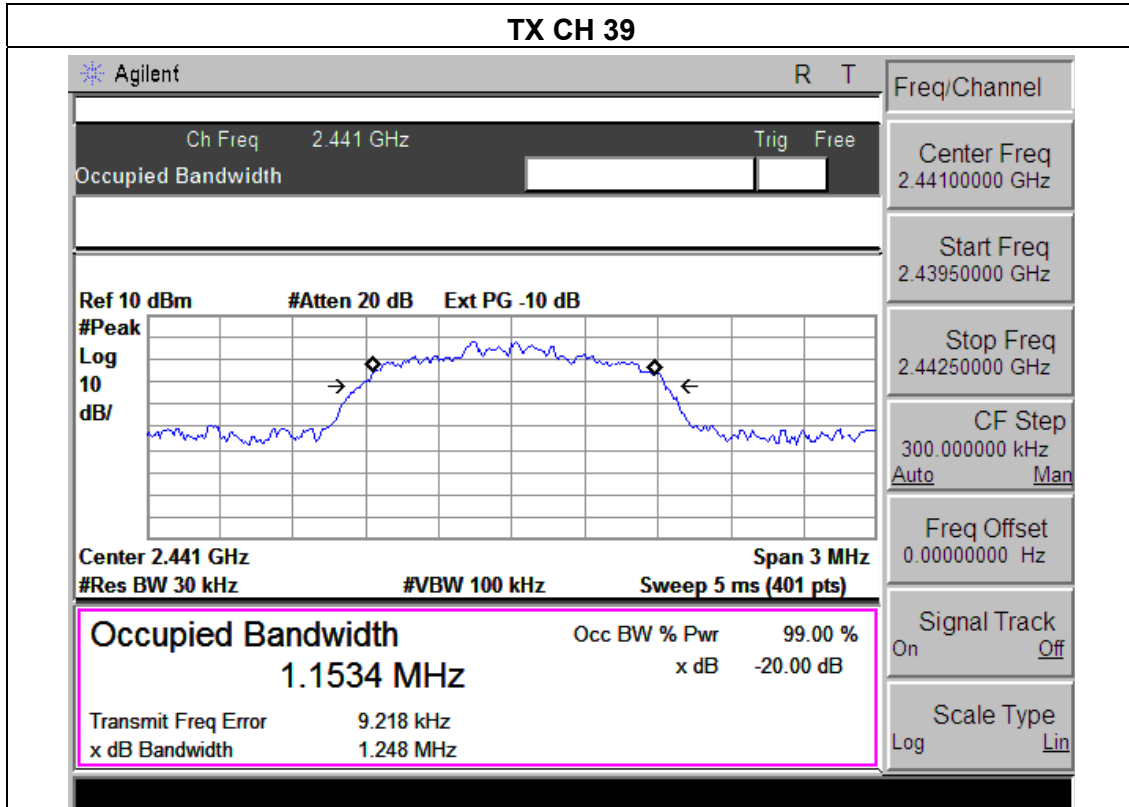



## **5. ANTENNA REQUIREMENT**

### **5.1 STANDARD REQUIREMENT**

15.203 requirement: For intentional device, according to 15.203: an intentional radiator shall be designed to ensure that no antenna other than that furnished by the responsible party shall be used with the device.

### **5.2 EUT ANTENNA**

The EUT antenna is PCB antenna,. It comply with the standard requirement.

## 6. TEST SEUUP PHOTO

### Radiated Measurement Photos



### Conducted Measurement Photos



## 7. EUT PHOTO





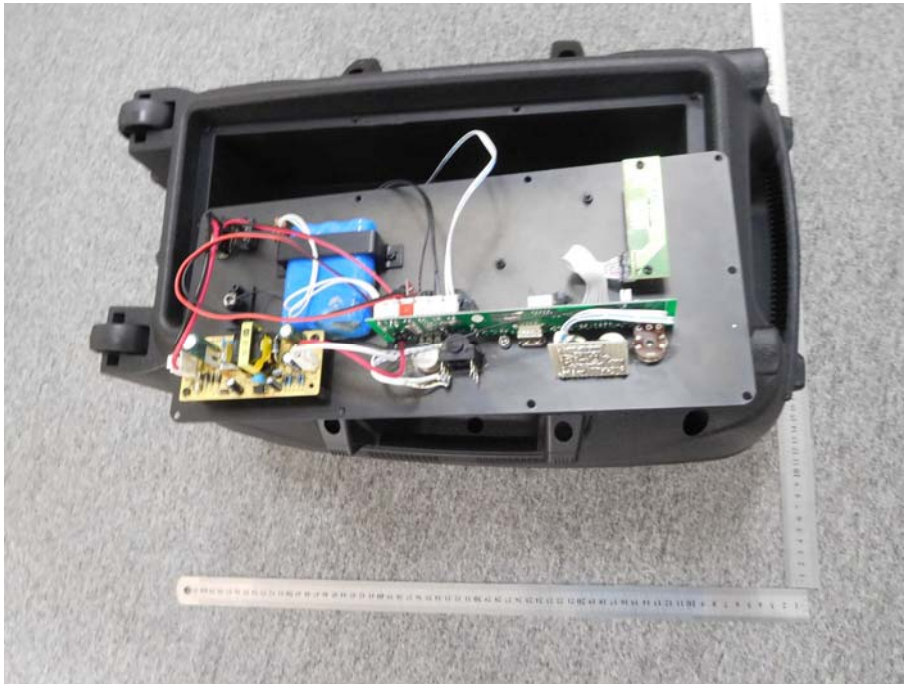

※ ※ ※ ※ ※ END OF REPORT ※ ※ ※ ※ ※