



FCC Part 15C Test Report

FCC ID: 2AHU836215AUES

Product Name:	Speaker Box
Trademark:	N/A
Model Name :	PP-36215AUES SBX-621510, SBX-621511, SBX-621512, PP-3615AUES, E-B52, PP-39215AUES, PP-29215AUES, PP-19215AUES, PP-21215AUES
Prepared For :	Ningbo Polinata Electronics Co., Ltd.
Address :	Tiantongzhuang Village Wuxiang Town, Yinzhou District, Ningbo City, China
Prepared By :	Shenzhen BCTC Technology Co., Ltd.
Address :	No.101, Yousong Road, Longhua New District, Shenzhen, China
Test Date:	Mar. 17 - Mar. 26, 2016
Date of Report :	Mar. 27, 2016
Report No.:	BCTC-160302535E



VERIFICATION OF COMPLIANCE

Applicant's name : **Ningbo Polinata Electronics Co., Ltd.**
Address..... : Tiantongzhuang Village Wuxiang Town, Yinzhou District, Ningbo City, China
Manufacturer's Name : **Ningbo Polinata Electronics Co., Ltd.**
Address..... : Tiantongzhuang Village Wuxiang Town, Yinzhou District, Ningbo City, China

Product description

Product name : Speaker Box
Trademark: N/A
 Model Name: PP-36215AUES
 SBX-621510, SBX-621511, SBX-621512, PP-3615AUES, E-B52, PP-39215AUES, PP-29215AUES, PP-19215AUES, PP-21215AUES
Test procedure FCC Part15.249
Standards ANSI C63.10-2013

This device described above has been tested by BCTC, and the test results show that the equipment under test (EUT) is in compliance with the FCC requirements. And it is applicable only to the tested sample identified in the report.

This report shall not be reproduced except in full, without the written approval of BCTC, this document may be altered or revised by BCTC, personal only, and shall be noted in the revision of the document.

Test Result.....: **Pass**

Testing Engineer : Eric Yang
 (Eric Yang)

Technical Manager : Sophie Lu
 (Sophia Lee)

Authorized Signatory : Carson Zhang
 (Carson. Zhang)





Table of Contents	Page
1 . SUMMARY OF TEST RESULTS	4
1.1 TEST FACILITY	4
1.2 MEASUREMENT UNCERTAINTY	4
2 . GENERAL INFORMATION	5
2.1 GENERAL DESCRIPTION OF EUT	5
2.2 DESCRIPTION OF TEST MODES	6
2.3 TABLE OF PARAMETERS OF TEXT SOFTWARE SETTING	6
2.4 BLOCK DIGRAM SHOWING THE CONFIGURATION OF SYSTEM TESTED	7
2.5 DESCRIPTION OF SUPPORT UNITS(CONDUCTED MODE)	7
2.6 EQUIPMENTS LIST FOR ALL TEST ITEMS	8
3 . EMC EMISSION TEST	9
3.1 CONDUCTED EMISSION MEASUREMENT	9
3.1.1 POWER LINE CONDUCTED EMISSION LIMITS	9
3.1.2 TEST PROCEDURE	10
3.1.3 DEVIATION FROM TEST STANDARD	10
3.1.4 TEST SETUP	10
3.1.5 EUT OPERATING CONDITIONS	10
3.1.6 TEST RESULTS	11
3.2 RADIATED EMISSION MEASUREMENT	13
3.2.1 RADIATED EMISSION LIMITS	13
3.2.2 TEST PROCEDURE	14
3.2.3 DEVIATION FROM TEST STANDARD	14
3.2.4 TEST SETUP	15
3.2.5 EUT OPERATING CONDITIONS	16
3.2.6 TEST RESULTS	17
4 . BANDWIDTH TEST	23
4.1 APPLIED PROCEDURES / LIMIT	23
4.1.1 TEST PROCEDURE	23
4.1.2 DEVIATION FROM STANDARD	23
4.1.3 TEST SETUP	23
4.1.4 EUT OPERATION CONDITIONS	23
4.1.5 TEST RESULTS	24
5 . 100 KHZ BANDWIDTH OF FREQUENCY BAND EDGE	28
5.1 DEVIATION FROM STANDARD	28
5.2 EUT OPERATION CONDITIONS	28
5.3 TEST RESULTS	28
6 . ANTENNA REQUIREMENT	43
6.1 STANDARD REQUIREMENT	43
6.2 EUT ANTENNA	43
7 . EUT TEST PHOTO	44
8 . PHOTOS OF THE EUT	46



1. SUMMARY OF TEST RESULTS

Test procedures according to the technical standards:

FCC Part15 (15.249) , Subpart C			
Standard Section	Test Item	Judgment	Remark
15.207	Conducted Emission	PASS	
15.249	Fundamental & Radiated Spurious Emission Measurement	PASS	
15.249	Bandwidth	PASS	
15.205	Band Edge Emission	PASS	
15.203	Antenna Requirement	PASS	

NOTE:

(1) "N/A" denotes test is not applicable in this Test Report

1.1 TEST FACILITY

Shenzhen BCTC Technology Co., Ltd.
Add.: No.101, Yousong Road, Longhua New District, Shenzhen, China
FCC Registration No.: 187086

1.2 MEASUREMENT UNCERTAINTY

The reported uncertainty of measurement $y \pm U$, where expanded uncertainty U is based on a standard uncertainty multiplied by a coverage factor of $k=2$, providing a level of confidence of approximately **95** %.

No.	Item	Uncertainty
1	Conducted Emission Test	± 1.38 dB
2	RF power, conducted	± 0.16 dB
3	Spurious emissions, conducted	± 0.21 dB
4	All emissions, radiated (<1G)	± 4.68 dB
5	All emissions, radiated (>1G)	± 4.89 dB
6	Temperature	± 0.5 °C
7	Humidity	± 2 %



2. GENERAL INFORMATION

2.1 GENERAL DESCRIPTION OF EUT

Equipment	Speaker Box										
Trade Name	N/A										
Model Name	PP-36215AUES										
Serial Model	SBX-621510, SBX-621511, SBX-621512, PP-3615AUES, E-B52, PP-39215AUES, PP-29215AUES, PP-19215AUES, PP-21215AUES										
Model Difference	The product's different for model number and outlook color.										
Product Description	<table border="1"> <tr> <td>Operation Frequency:</td> <td>2402~2480 MHz</td> </tr> <tr> <td>Modulation Type:</td> <td>GFSK, PI/4 DPSK, 8DPSK</td> </tr> <tr> <td>Bit Rate of Transmitter</td> <td>1/2/3M</td> </tr> <tr> <td>Number Of Channel</td> <td>79CH</td> </tr> <tr> <td>Antenna Designation:</td> <td>Please see Note 3.</td> </tr> </table> <p>Based on the application, features, or specification exhibited in User's Manual, the EUT is considered as an ITE/Computing Device. More details of EUT technical specification, please refer to the User's Manual.</p>	Operation Frequency:	2402~2480 MHz	Modulation Type:	GFSK, PI/4 DPSK, 8DPSK	Bit Rate of Transmitter	1/2/3M	Number Of Channel	79CH	Antenna Designation:	Please see Note 3.
Operation Frequency:	2402~2480 MHz										
Modulation Type:	GFSK, PI/4 DPSK, 8DPSK										
Bit Rate of Transmitter	1/2/3M										
Number Of Channel	79CH										
Antenna Designation:	Please see Note 3.										
Channel List	Please refer to the Note 2.										
Power	AC120V/60Hz AC 230V/50Hz										
Connecting I/O Port(s)	Please refer to the User's Manual										
hardware version	--										
Software version	--										
Serial number	--										

Note:

1. For a more detailed features description, please refer to the manufacturer's specifications or the User's Manual.
- 2.

Channel List					
Channel	Frequency (MHz)	Channel	Frequency (MHz)	Channel	Frequency (MHz)
01	2402	11	2413	38	2441
02	2403	12	2414	39	2441
03	2404	13	2415	40	2442
~	~	~	~	~	~
09	2411	19	2421	77	2479
10	2412	20	2422	78	2480



3. Table for Filed Antenna

Ant	Brand	Model Name	Antenna Type	Connector	Gain (dBi)	NOTE
1	N/A	N/A	PCB Antenna	N/A	0	

2.2 DESCRIPTION OF TEST MODES

To investigate the maximum EMI emission characteristics generates from EUT, the test system was pre-scanning tested base on the consideration of following EUT operation mode or test configuration mode which possible have effect on EMI emission level. Each of these EUT operation mode(s) or test configuration mode(s) mentioned above was evaluated respectively.

For Conducted & Radiated Emission		
Final Test Mode	Description	
Mode 1	CH01	GFSK, PI/4 DPSK 8DPSK
Mode 2	CH39	
Mode 3	CH78	
Mode 4	Normal Link	

Note:

- (1) The measurements are performed at the highest, middle, lowest available channels.
- (2) Fully-charged battery is used during the test

2.3 TABLE OF PARAMETERS OF TEXT SOFTWARE SETTING

During testing channel & power controlling software provided by the customer was used to control the operating channel as well as the output power level. The RF output power selection is for the setting of RF output power expected by the customer and is going to be fixed on the firmware of the final end product power parameters of FHSS

Frequency	2402 MHz	2441 MHz	2480 MHz
Channel	Low	Middle	High



2.4 BLOCK DIGRAM SHOWING THE CONFIGURATION OF SYSTEM TESTED

Emission Test

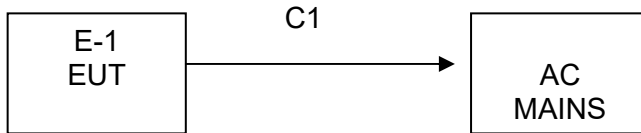

2.5 DESCRIPTION OF SUPPORT UNITS(CONDUCTED MODE)

The EUT has been tested as an independent unit together with other necessary accessories or support units. The following support units or accessories were used to form a representative test configuration during the tests.

Item	Equipment	Mfr/Brand	Model/Type No.	Series No.	Note
E-1	Speaker Box	N/A	PP-36215AUES	N/A	EUT

Item	Shielded Type	Ferrite Core	Length	Note
C1	NO Shielded	NO	0.8M	AC Line

Note:

- (1) The support equipment was authorized by Declaration of Confirmation.
- (2) For detachable type I/O cable should be specified the length in cm in 『Length』 column.
- (3) “YES” is means “shielded” “with core”; “NO” is means “unshielded” “without core”.



2.6 EQUIPMENTS LIST FOR ALL TEST ITEMS

Conduction Test equipment

Item	Kind of Equipment	Manufacturer	Type No.	Serial No.	Last calibration	Calibrated until	Calibration period
1	Test Receiver	R&S	ESCI	1166.5950K03-101165-ha	2015.06.05	2016.06.05	1 year
2	LISN	R&S	NSLK8126	8126466	2015.08.24	2016.08.23	1 year
3	LISN	R&S	NSLK8126	8126487	2015.08.24	2016.08.23	1 year
4	50Ω Coaxial Switch	Anritsu	MP59B	6200264417	2015.06.05	2016.06.05	1 year
5	RF cables	R&S	R204	R20X	2015.06.05	2016.06.05	1 year

Radiation test, Band-edge test and 20db bandwidth test equipment

Item	Kind of Equipment	Manufacturer	Type No.	Serial No.	Last calibration	Calibrated until	Calibration period
1	Spectrum Analyzer	Agilent	E4407B	MY45108040	2015.06.05	2016.06.05	1 year
2	Test Receiver	R&S	ESPI	101318	2015.06.05	2016.06.05	1 year
3	Bilog Antenna	R&S	VULB9168	VULB9168-438	2015.06.05	2016.06.05	1 year
4	50Ω Coaxial Switch	Anritsu	MP59B	6200264416	2015.06.05	2016.06.05	1 year
5	Spectrum Analyzer	ADVANTEST	R3132	150900201	2015.06.05	2016.06.05	1 year
6	Horn Antenna	R&S	HF906	10027	2015.06.05	2016.06.05	1 year
7	Horn Ant	Schwarzbeck	BBHA 9170	9170-181	2015.06.05	2016.06.05	1 year
8	Amplifier	R&S	BBV9743	9743-019	2015.12.22	2016.12.21	1 year
9	Loop Antenna	ARA	PLA-1030/B	1029	2015.06.05	2016.06.05	1 year
10	RF cables	R&S	R203	R20X	2015.06.05	2016.06.05	1 year
11	Antenna connector	Florida RFLabs	Lab-Fle	RF 01#	2015.06.05	2016.06.05	1 year



3. EMC EMISSION TEST

3.1 CONDUCTED EMISSION MEASUREMENT

3.1.1 POWER LINE CONDUCTED EMISSION Limits (Frequency Range 150KHz-30MHz)

FREQUENCY (MHz)	Class A (dBuV)		Class B (dBuV)		Standard
	Quasi-peak	Average	Quas -peak	Average	
0.15 -0.5	79.00	66.00	66 - 56 *	56 - 46 *	CISPR
0.50 -5.0	73.00	60.00	56.00	46.00	CISPR
5.0 -30.0	73.00	60.00	60.00	50.00	CISPR

0.15 -0.5	79.00	66.00	66 - 56 *	56 - 46 *	FCC
0.50 -5.0	73.00	60.00	56.00	46.00	FCC
5.0 -30.0	73.00	60.00	60.00	50.00	FCC

Note:

- (1) The tighter limit applies at the band edges.
- (2) The limit of " * " marked band means the limitation decreases linearly with the logarithm of the frequency in the range.

The following table is the setting of the receiver

Receiver Parameters	Setting
Attenuation	10 dB
Start Frequency	0.15 MHz
Stop Frequency	30 MHz
IF Bandwidth	9 kHz

3.1.2 TEST PROCEDURE

- The EUT was placed 0.1 meters from the horizontal ground plane with EUT being connected to the power mains through a line impedance stabilization network (LISN). All other support equipments powered from additional LISN(s). The LISN provide 50 Ohm/ 50uH of coupling impedance for the measuring instrument.
- Interconnecting cables that hang closer than 40 cm to the ground plane shall be folded back and forth in the center forming a bundle 30 to 40 cm long.
- I/O cables that are not connected to a peripheral shall be bundled in the center. The end of the cable may be terminated, if required, using the correct terminating impedance. The overall length shall not exceed 1 m.
- LISN at least 80 cm from nearest part of EUT chassis.
- For the actual test configuration, please refer to the related Item –EUT Test Photos.

3.1.3 DEVIATION FROM TEST STANDARD

No deviation

3.1.4 TEST SETUP

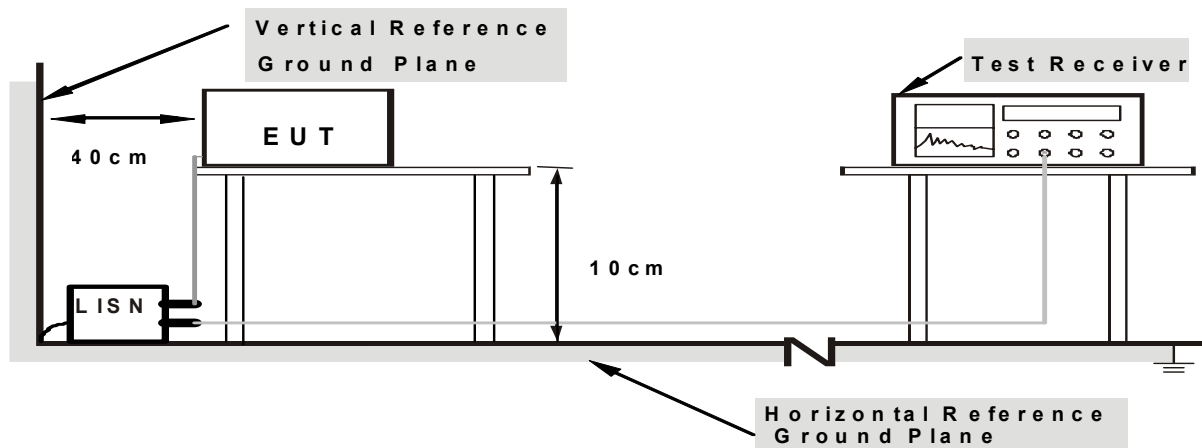

- Note: 1. Support units were connected to second LISN.
2. Both of LISNs (AMN) are 80 cm from EUT and at least 80 cm from other units and other metal planes

3.1.5 EUT OPERATING CONDITIONS

The EUT was configured for testing in a typical fashion (as a customer would normally use it). The EUT has been programmed to continuously transmit during test. This operating condition was tested and used to collect the included data.

We pretest AC 120V and AC 240V, the worst voltage was AC 120V and the data recording in the report.



3.1.6 TEST RESULTS

EUT :	Speaker Box	Model Name. :	PP-36215AUES
Temperature :	26°C	Relative Humidity :	54%
Pressure :	1010hPa	Phase :	L
Test Voltage :	AC120V/60Hz	Test Mode :	Mode 4

No. Mk.	Freq. MHz	Reading Level dBuV	Correct Factor dB	Measurement dBuV	Limit dBuV	Over dB	Detector	Comment
1	0.2060	49.57	10.07	59.64	63.36	-3.72	QP	
2	0.2060	12.77	10.07	22.84	53.36	-30.52	AVG	
3	0.3634	44.23	10.10	54.33	58.65	-4.32	QP	
4	0.3634	16.52	10.10	26.62	48.65	-22.03	AVG	
5	0.3860	44.17	10.10	54.27	58.15	-3.88	QP	
6	0.3860	11.16	10.10	21.26	48.15	-26.89	AVG	
7	0.4099	15.71	10.11	25.82	47.65	-21.83	AVG	
8	0.4100	42.94	10.11	53.05	57.65	-4.60	QP	
9	0.4100	15.74	10.11	25.85	47.65	-21.80	AVG	
10 *	0.4460	43.20	10.11	53.31	56.95	-3.64	QP	
11	0.4460	15.32	10.11	25.43	46.95	-21.52	AVG	
12	0.6820	35.12	10.13	45.25	56.00	-10.75	QP	
13	0.6820	4.35	10.13	14.48	46.00	-31.52	AVG	

Remark:

1. All readings are Quasi-Peak and Average values.
2. Factor = Insertion Loss + Cable Loss.

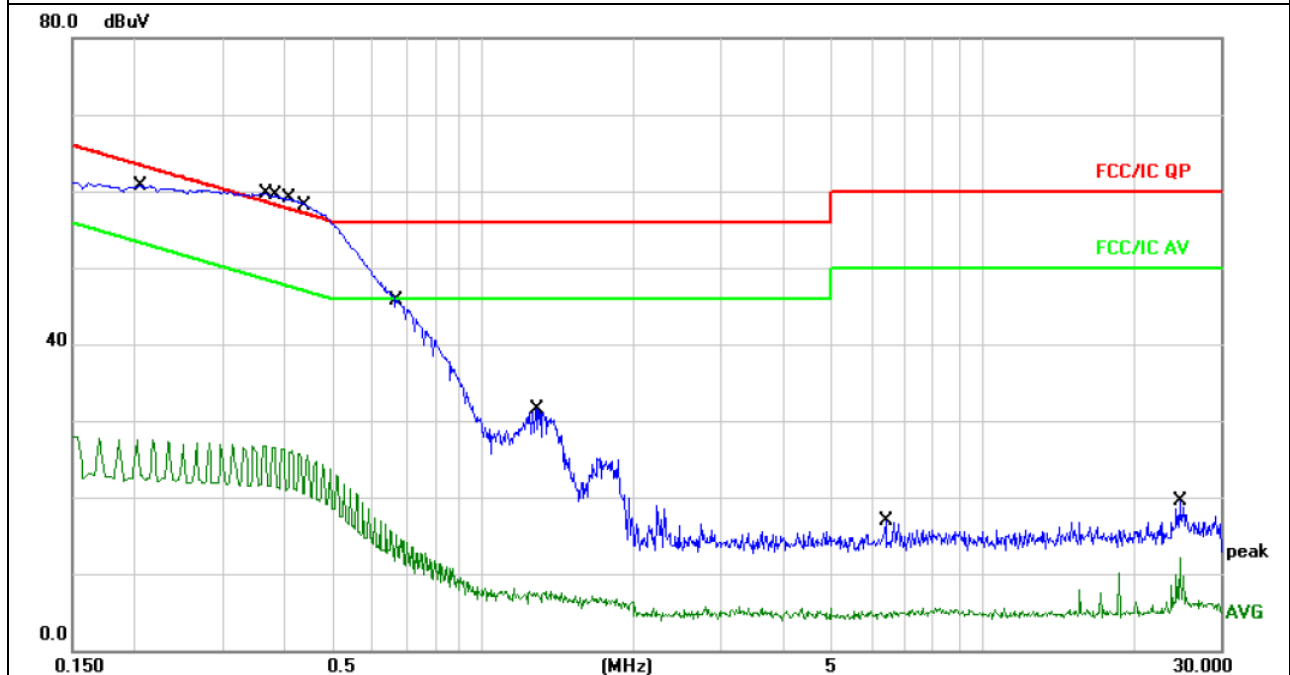



EUT :	Speaker Box	Model Name. :	PP-36215AUES
Temperature :	26°C	Relative Humidity :	54%
Pressure :	1010hPa	Phase :	N
Test Voltage :	AC120V/60Hz	Test Mode :	Mode 4

No.	Mk.	Freq.	Reading Level	Correct Factor	Measurement	Limit	Over	Detector	Comment
		MHz	dBuV	dB	dBuV	dBuV	dB		
1		0.1980	50.31	10.06	60.37	63.69	-3.32	QP	
2		0.1980	17.16	10.06	27.22	53.69	-26.47	AVG	
3		0.3860	43.00	10.10	53.10	58.15	-5.05	QP	
4		0.3860	15.78	10.10	25.88	48.15	-22.27	AVG	
5	*	0.4100	45.17	10.11	55.28	57.65	-2.37	QP	
6		0.4100	15.46	10.11	25.57	47.65	-22.08	AVG	
7		0.4304	44.26	10.11	54.37	57.24	-2.87	QP	
8		0.4304	10.23	10.11	20.34	47.24	-26.90	AVG	
9		1.2500	21.68	10.17	31.85	56.00	-24.15	QP	
10		1.2500	-1.91	10.17	8.26	46.00	-37.74	AVG	
11		2.4260	4.60	10.18	14.78	56.00	-41.22	QP	
12		2.4260	-4.85	10.18	5.33	46.00	-40.67	AVG	
13		4.8220	8.75	10.15	18.90	56.00	-37.10	QP	

Remark:

1. All readings are Quasi-Peak and Average values.
2. Factor = Insertion Loss + Cable Loss.

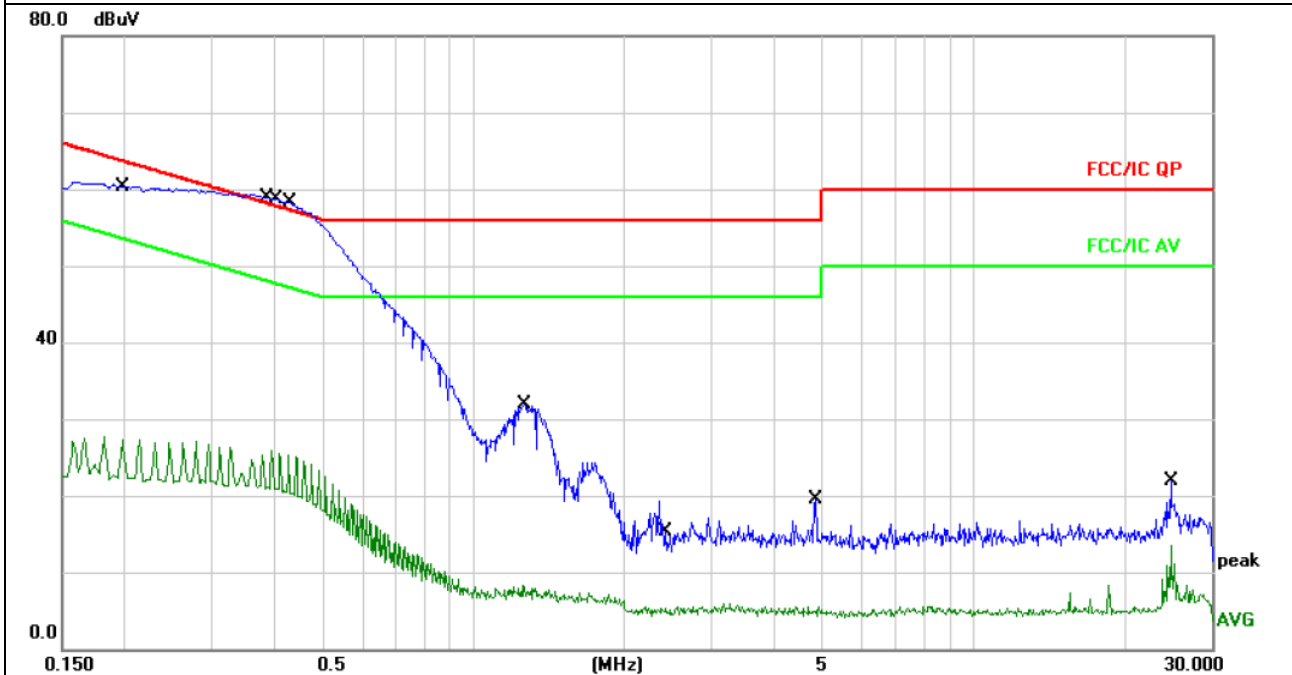



3.2 RADIATED EMISSION MEASUREMENT

3.2.1 RADIATED EMISSION LIMITS (Frequency Range 9kHz-1000MHz)

20dBc in any 100 kHz bandwidth outside the operating frequency band. In case the emission fall within the restricted band specified on 15.205(a), then the 15.209(a) limit in the table below has to be followed.

Frequencies (MHz)	Field Strength (micorvolts/meter)	Measurement Distance (meters)
0.009~0.490	2400/F(KHz)	300
0.490~1.705	24000/F(KHz)	30
1.705~30.0	30	30
30~88	100	3
88~216	150	3
216~960	200	3
Above 960	500	3

LIMITS OF RADIATED EMISSION MEASUREMENT (Above 1000MHz)

FREQUENCY (MHz)	Class B (dBuV/m) (at 3M)	
	PEAK	AVERAGE
Above 1000	74	54

Notes:

- (1) The limit for radiated test was performed according to FCC PART 15C.
- (2) The tighter limit applies at the band edges.
- (3) Emission level (dBuV/m)=20log Emission level (uV/m).

FREQUENCY RANGE OF RADIATED MEASUREMENT (For unintentional radiators)

Highest frequency generated or Upper frequency of measurement used in the device or on which the device operates or tunes (MHz)	Range (MHz)
Below 1.705	30
1.705 – 108	1000
108 – 500	2000
500 – 1000	5000
Above 1000	5 th harmonic of the highest frequency or 40 GHz, whichever is lower



Spectrum Parameter	Setting
Attenuation	Auto
Start Frequency	1000 MHz
Stop Frequency	10th carrier harmonic
RB / VB (emission in restricted band)	1 MHz / 1 MHz for Peak, 1 MHz / 10Hz for Average

Receiver Parameter	Setting
Attenuation	Auto
Start ~ Stop Frequency	9kHz~150kHz / RB 200Hz for QP
Start ~ Stop Frequency	150kHz~30MHz / RB 9kHz for QP
Start ~ Stop Frequency	30MHz~1000MHz / RB 120kHz for QP

3.2.2 TEST PROCEDURE

- a. The measuring distance of at 3 m shall be used for measurements at frequency up to 25GHz. For frequencies above 1GHz, any suitable measuring distance may be used.
- b. The EUT was placed on the top of a rotating table 1.5 meters above the ground at a 3 meter chamber test site. The table was rotated 360 degrees to determine the position of the highest radiation.
- c. The height of the equipment or of the substitution antenna shall be 0.1 m; the height of the test antenna shall vary between 1 m to 4 m. Both horizontal and vertical polarizations of the antenna are set to make the measurement.
- d. The initial step in collecting conducted emission data is a spectrum analyzer peak detector mode pre-scanning the measurement frequency range. Significant peaks are then marked and then Quasi Peak detector mode re-measured.
- e. If the Peak Mode measured value compliance with and lower than Quasi Peak Mode Limit, the EUT shall be deemed to meet QP Limits and then no additional QP Mode measurement performed.
- f. For the actual test configuration, please refer to the related Item –EUT Test Photos.
- g. For the radiated emission test above 1GHz:

Place the measurement antenna away from each area of the EUT determined to be a source of emissions at the specified measurement distance, while keeping the measurement antenna aimed at the source of emissions at each frequency of significant emissions, with polarization oriented for maximum response.

The measurement antenna may have to be higher or lower than the EUT, depending on the radiation pattern of the emission and staying aimed at the emission source for receiving the maximum signal. The final measurement antenna elevation shall be that which maximizes the emissions. The measurement antenna elevation for maximum emissions shall be restricted to a range of heights of from 1 m to 4 m above the ground or reference ground plane.

Note:

Both horizontal and vertical antenna polarities were tested and performed pretest to three orthogonal axis. The worst case emissions were reported We pretest AC 120V , and AC 240V, the worst voltage was AC 120V and the data recording in the report.

3.2.3 DEVIATION FROM TEST STANDARD

No deviation

3.2.4 TEST SETUP

(A) Radiated Emission Test-Up Frequency Below 30MHz

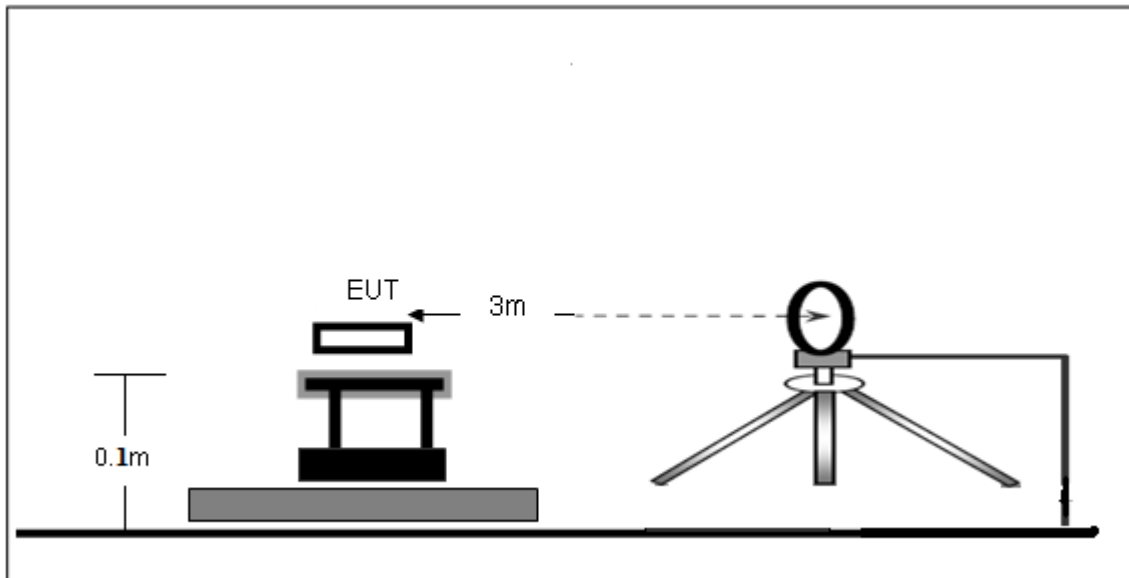

(B) Radiated Emission Test-Up Frequency 30MHz~1GHz

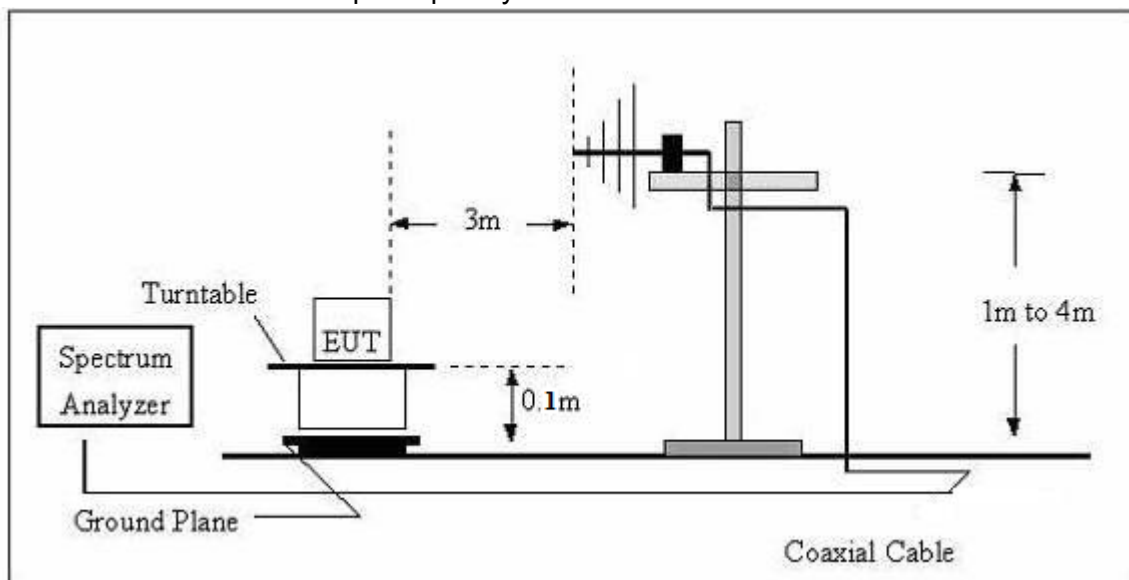

(C) Radiated Emission Test-Up Frequency Above 1GHz

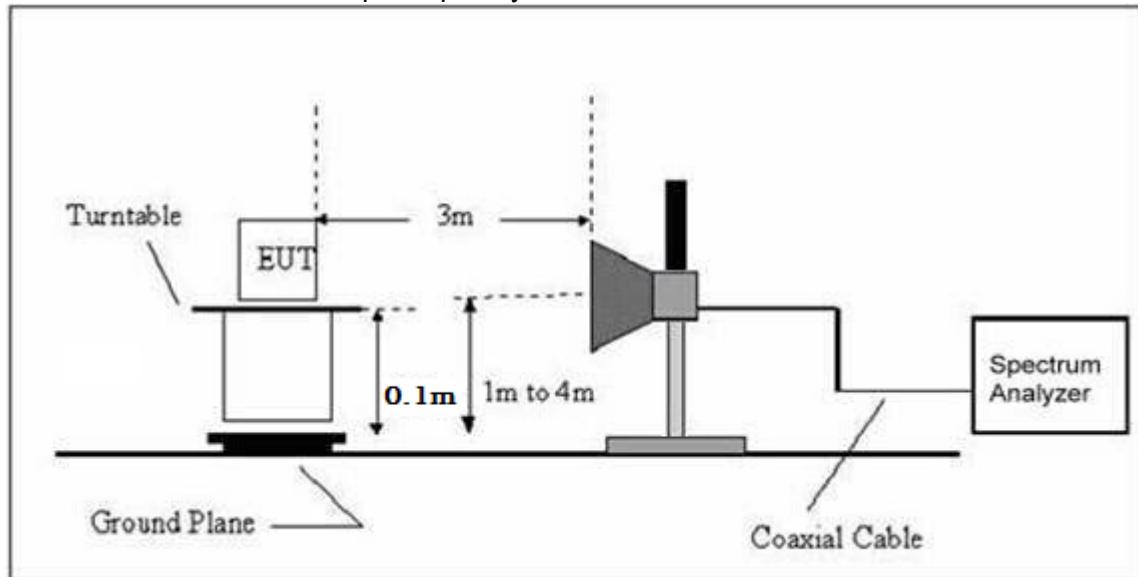

3.2.5 EUT OPERATING CONDITIONS

The EUT tested system was configured as the statements of 2.4 Unless otherwise a special operating condition is specified in the follows during the testing.



3.2.6 TEST RESULTS

Radiated Spurious Emission (Below 30MHz)

EUT :	Speaker Box	Model Name :	PP-36215AUES
Temperature :	20 °C	Relative Humidity :	48%
Pressure :	1010 hPa	Polarization :	---
Test Voltage :	AC 120V/60Hz		
Test Mode :	Normal Link		

Freq.	Reading	Limit	Margin	State
(MHz)	(dBuV/m)	(dBuV/m)	(dB)	P/F
--	--	--	--	PASS
--	--	--	--	PASS

NOTE:

The amplitude of spurious emissions which are attenuated by more than 20dB below the permissible value has no need to be reported.

Distance extrapolation factor = $40 \log (\text{specific distance}/\text{test distance})$ (dB);

Limit line = specific limits(dBuv) + distance extrapolation factor.



Radiated Spurious Emission (Between 30MHz – 1GHz)

EUT :	Speaker Box	Model Name :	PP-36215AUES
Temperature :	26 °C	Relative Humidity :	54%
Pressure :	1010 hPa	Polarization :	Horizontal
Test Voltage :	AC120V/60Hz		
Test Mode : (Worst)	Mode 4		

No. Mk.	Freq. MHz	Reading Level dBuV	Correct Factor dB/m	Measure- ment dBuV/m	Limit dBuV/m	Over dB	Detector	Antenna Height cm	Table Degree degree	Comment
1	35.1278	38.36	-8.51	29.85	40.00	-10.15	QP			
2	74.9191	35.40	-16.29	19.11	40.00	-20.89	QP			
3	99.8777	47.99	-16.49	31.50	43.50	-12.00	QP			
4 *	287.9904	50.54	-12.89	37.65	46.00	-8.35	QP			
5	383.9318	44.17	-10.57	33.60	46.00	-12.40	QP			
6	672.8445	37.95	-4.80	33.15	46.00	-12.85	QP			

Remark:
 Factor = Antenna Factor + Cable Loss – Pre-amplifier.
 All interfaces was connected, and BT TX mode was link.

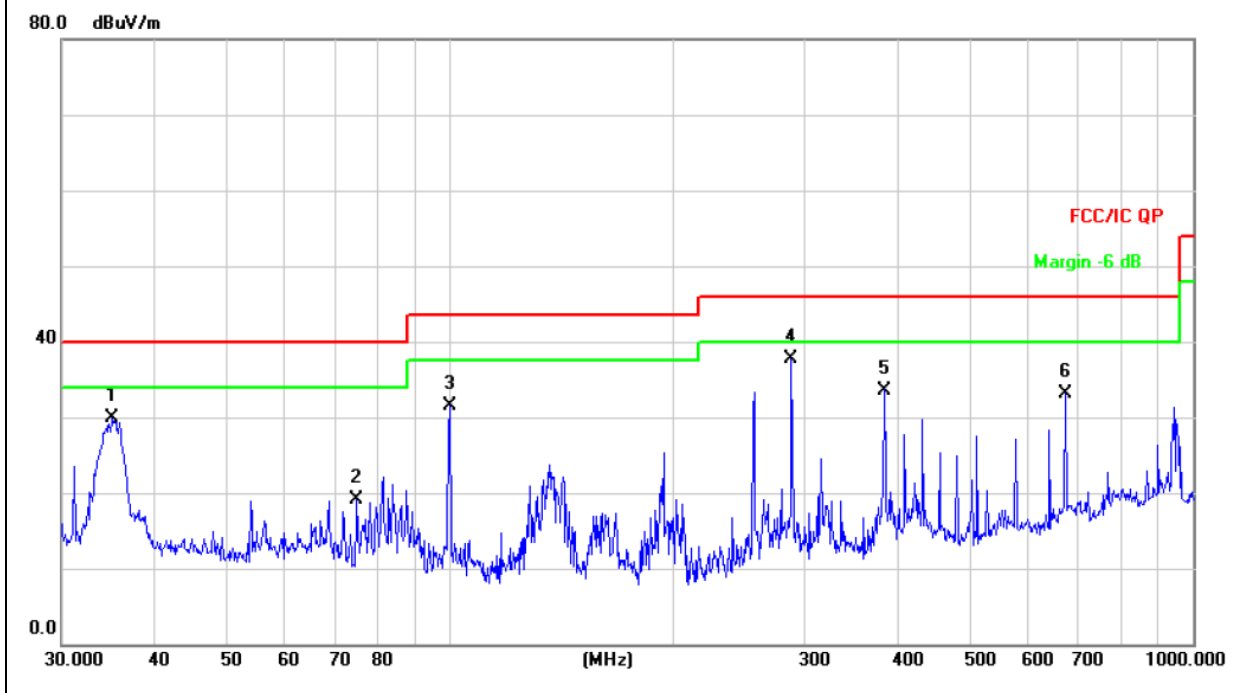



EUT :	Speaker Box	Model Name :	PP-36215AUES
Temperature :	26 °C	Relative Humidity :	54%
Pressure :	1010 hPa	Polarization :	Vertical
Test Voltage :	AC120V/60Hz		
Test Mode : (Worst)	Mode 4		

No.	Mk.	Freq. MHz	Reading Level dBuV	Correct Factor dB/m	Measure- ment dBuV/m	Limit dBuV/m	Over dB	Detector	Antenna Height cm	Table Degree degree	Comment
1		35.4993	31.69	-8.55	23.14	40.00	-16.86	QP			
2	*	80.9275	53.81	-18.10	35.71	40.00	-4.29	QP			
3		135.0319	35.70	-13.74	21.96	43.50	-21.54	QP			
4		256.5211	51.50	-14.01	37.49	46.00	-8.51	QP			
5		383.9318	45.72	-10.57	35.15	46.00	-10.85	QP			
6		672.8445	37.35	-4.80	32.55	46.00	-13.45	QP			

Remark:
 Factor = Antenna Factor + Cable Loss – Pre-amplifier.
 All interfaces was connected, and BT TX mode was link.

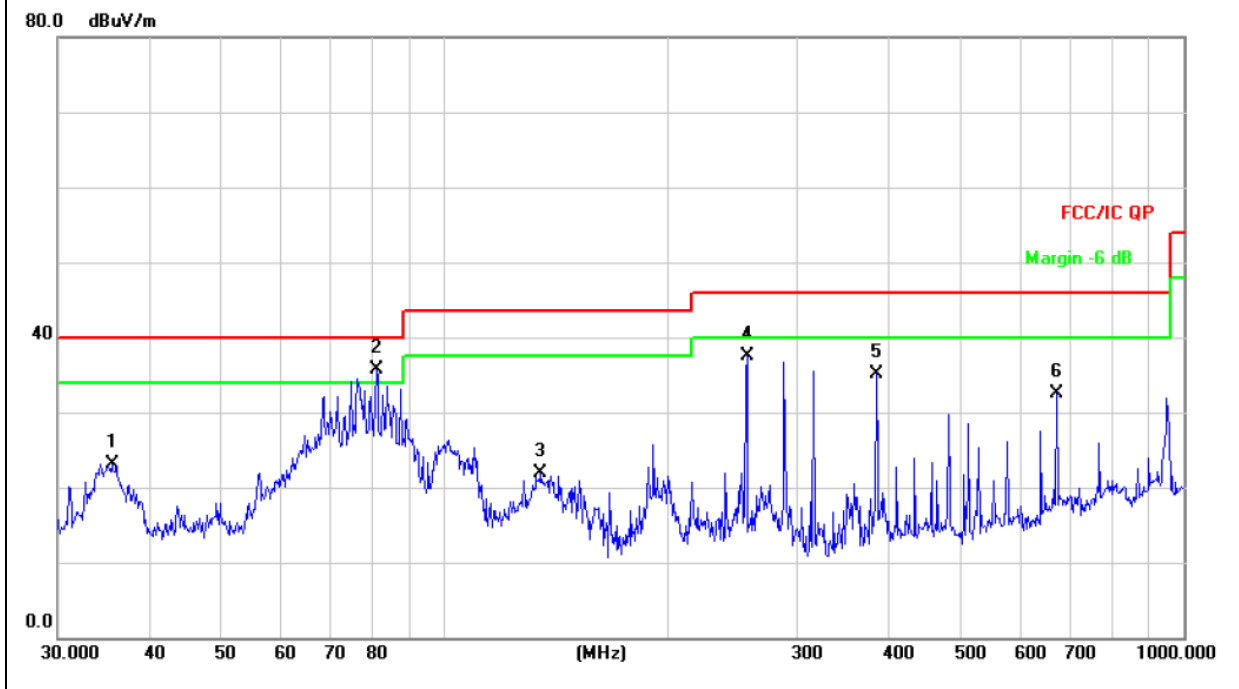



Radiated Spurious Emission (1GHz to 10th harmonics)
GFSK

	Freq.	Receiver Reading	Detector	Polar	Corrected Factor	Emission Level	Limit	Result
	(MHz)	(dBμV)	(PK/QP/Ave)	(H/V)	(dB)	(dBμV/m)	(dBμV/m)	
Lower Channel 2402MHz	2402.00	103.15	PK	H	1.31	104.46	114.00	Pass
	2402.00	88.68	Ave	H	1.31	89.99	94.00	Pass
	4804.00	55.79	PK	H	-1.06	54.73	74.00	Pass
	4804.00	45.79	Ave	H	-1.06	44.73	54.00	Pass
	10320.00	42.36	PK	H	-4.62	37.74	74.00	Pass
	17581.00	45.87	PK	H	-6.05	39.82	74.00	Pass
	2402.00	102.86	PK	V	1.31	104.17	114.00	Pass
	2402.00	89.18	Ave	V	1.31	90.49	94.00	Pass
	4804.00	54.94	PK	V	-1.06	53.88	74.00	Pass
	4804.00	45.59	Ave	V	-1.06	44.53	54.00	Pass
	12314.00	43.06	PK	V	-5.14	37.92	74.00	Pass
	17895.00	45.98	PK	V	-6.54	39.44	74.00	Pass
	Middle Channel 2441MHz	2441.00	103.27	PK	H	0.85	104.12	114.00
2441.00		88.75	Ave	H	0.85	89.60	94.00	Pass
4880.00		57.51	PK	H	-0.62	56.89	74.00	Pass
4880.00		48.56	Ave	H	-0.62	47.94	54.00	Pass
10320.00		42.54	PK	H	-4.62	37.92	74.00	Pass
17581.00		45.66	PK	H	-6.05	39.61	74.00	Pass
2441.00		103.72	PK	V	0.85	104.57	114.00	Pass
2441.00		87.69	Ave	V	0.85	88.54	94.00	Pass
4880.00		57.13	PK	V	-0.62	56.51	74.00	Pass
4880.00		48.27	Ave	V	-0.62	47.65	54.00	Pass
12314.00		43.18	PK	V	-5.14	38.04	74.00	Pass
17895.00		45.76	PK	V	-6.54	39.22	74.00	Pass
Upper Channel 2480MHz	2480.00	104.11	PK	H	0.53	104.64	114.00	Pass
	2480.00	88.29	Ave	H	0.53	88.82	94.00	Pass
	4960.00	57.80	PK	H	-0.24	57.56	74.00	Pass
	4960.00	48.86	Ave	H	-0.24	48.62	54.00	Pass
	10320.00	42.58	PK	H	-4.62	37.96	74.00	Pass
	17581.00	45.97	PK	H	-6.05	39.92	74.00	Pass
	2480.00	103.74	PK	V	0.53	104.27	114.00	Pass
	2480.00	88.67	Ave	V	0.53	89.20	94.00	Pass
	4960.00	57.56	PK	V	-0.24	57.32	74.00	Pass
	4960.00	47.55	Ave	V	-0.24	47.31	54.00	Pass
	12314.00	42.89	PK	V	-5.14	37.75	74.00	Pass
	17895.00	45.17	PK	V	-6.54	38.63	74.00	Pass

Remark:

Factor = Antenna Factor + Cable Loss – Pre-amplifier.

Emission Level = Meter Reading + Factor

Margin = Emission Level - Limit

Other harmonics emissions are lower than 20dB below the allowable limit.



PI/4 DPSK

	Freq.	Receiver Reading	Detector	Polar	Corrected Factor	Emission Level	Limit	Result
	(MHz)	(dBμV)	(PK/QP/Ave)	(H/V)	(dB)	(dBμV/m)	(dBμV/m)	
Lower Channel 2402MHz	2402.00	102.07	PK	H	1.31	103.38	114.00	Pass
	2402.00	88.01	Ave	H	1.31	89.32	94.00	Pass
	4804.00	57.11	PK	H	-1.06	56.05	74.00	Pass
	4804.00	48.23	Ave	H	-1.06	47.17	54.00	Pass
	10320.00	42.58	PK	H	-4.62	37.96	74.00	Pass
	17581.00	45.09	PK	H	-6.05	39.04	74.00	Pass
	2402.00	101.00	PK	V	1.31	102.31	114.00	Pass
	2402.00	87.30	Ave	V	1.31	88.61	94.00	Pass
	4804.00	58.12	PK	V	-1.06	57.06	74.00	Pass
	4804.00	46.74	Ave	V	-1.06	45.68	54.00	Pass
	12314.00	43.47	PK	V	-5.14	38.33	74.00	Pass
	17895.00	45.59	PK	V	-6.54	39.05	74.00	Pass
Middle Channel 2441MHz	2441.00	101.93	PK	H	0.85	102.78	114.00	Pass
	2441.00	87.55	Ave	H	0.85	88.40	94.00	Pass
	4882.00	53.98	PK	H	-0.62	53.36	74.00	Pass
	4882.00	43.25	Ave	H	-0.62	42.63	54.00	Pass
	10320.00	42.59	PK	H	-4.62	37.97	74.00	Pass
	17581.00	45.11	PK	H	-6.05	39.06	74.00	Pass
	2441.00	101.84	PK	V	0.85	102.69	114.00	Pass
	2441.00	86.93	Ave	V	0.85	87.78	94.00	Pass
	4882.00	54.87	PK	V	-0.62	54.25	74.00	Pass
	4882.00	44.31	Ave	V	-0.62	43.69	54.00	Pass
	12314.00	43.37	PK	V	-5.14	38.23	74.00	Pass
17895.00	45.59	PK	V	-6.54	39.05	74.00	Pass	
Upper Channel 2480MHz	2480.00	102.14	PK	H	0.53	102.67	114.00	Pass
	2480.00	87.62	Ave	H	0.53	88.15	94.00	Pass
	4960.00	52.12	PK	H	-0.24	51.88	74.00	Pass
	4960.00	43.15	Ave	H	-0.24	42.91	54.00	Pass
	10320.00	42.59	PK	H	-4.62	37.97	74.00	Pass
	17581.00	45.44	PK	H	-6.05	39.39	74.00	Pass
	2480.00	101.29	PK	V	0.53	101.82	114.00	Pass
	2480.00	86.90	Ave	V	0.53	87.43	94.00	Pass
	4960.00	54.28	PK	V	-0.24	54.04	74.00	Pass
	4960.00	43.36	Ave	V	-0.24	43.12	54.00	Pass
	12314.00	43.58	PK	V	-5.14	38.44	74.00	Pass
17895.00	45.64	PK	V	-6.54	39.10	74.00	Pass	

Remark:

Factor = Antenna Factor + Cable Loss – Pre-amplifier.

Emission Level = Meter Reading + Factor

Margin = Emission Level - Limit

Other harmonics emissions are lower than 20dB below the allowable limit.



8DPSK

	Freq.	Receiver Reading	Detector	Polar	Corrected Factor	Emission Level	Limit	Result
	(MHz)	(dBμV)	(PK/QP/Ave)	(H/V)	(dB)	(dBμV/m)	(dBμV/m)	
Lower Channel 2402MHz	2402.00	102.82	PK	H	1.31	104.13	114.00	Pass
	2402.00	88.66	Ave	H	1.31	89.97	94.00	Pass
	4804.00	57.53	PK	H	-1.06	56.47	74.00	Pass
	4804.00	48.57	Ave	H	-1.06	47.51	54.00	Pass
	10320.00	42.87	PK	H	-4.62	38.25	74.00	Pass
	17581.00	45.66	PK	H	-6.05	39.61	74.00	Pass
	2402.00	101.74	PK	V	1.31	103.05	114.00	Pass
	2402.00	87.93	Ave	V	1.31	89.24	94.00	Pass
	4804.00	58.54	PK	V	-1.06	57.48	74.00	Pass
	4804.00	47.09	Ave	V	-1.06	46.03	54.00	Pass
	12314.00	43.59	PK	V	-5.14	38.45	74.00	Pass
	17895.00	45.76	PK	V	-6.54	39.22	74.00	Pass
	Middle Channel 2441MHz	2441.00	102.67	PK	H	0.85	103.52	114.00
2441.00		88.18	Ave	H	0.85	89.03	94.00	Pass
4882.00		54.37	PK	H	-0.62	53.75	74.00	Pass
4882.00		43.56	Ave	H	-0.62	42.94	54.00	Pass
10320.00		43.11	PK	H	-4.62	38.49	74.00	Pass
17581.00		45.67	PK	H	-6.05	39.62	74.00	Pass
2441.00		102.58	PK	V	0.85	103.43	114.00	Pass
2441.00		87.57	Ave	V	0.85	88.42	94.00	Pass
4882.00		55.27	PK	V	-0.62	54.65	74.00	Pass
4882.00		44.63	Ave	V	-0.62	44.01	54.00	Pass
12314.00		42.55	PK	V	-5.14	37.41	74.00	Pass
17895.00	45.76	PK	V	-6.54	39.22	74.00	Pass	
Upper Channel 2480MHz	2480.00	102.90	PK	H	0.53	103.43	114.00	Pass
	2480.00	88.26	Ave	H	0.53	88.79	94.00	Pass
	4960.00	52.49	PK	H	-0.24	52.25	74.00	Pass
	4960.00	43.46	Ave	H	-0.24	43.22	54.00	Pass
	10320.00	42.59	PK	H	-4.62	37.97	74.00	Pass
	17581.00	44.76	PK	H	-6.05	38.71	74.00	Pass
	2480.00	102.03	PK	V	0.53	102.37	114.00	Pass
	2480.00	87.54	Ave	V	0.53	87.90	94.00	Pass
	4960.00	54.68	PK	V	-0.24	54.34	74.00	Pass
	4960.00	43.67	Ave	V	-0.24	43.35	54.00	Pass
	12314.00	43.76	PK	V	-5.14	38.62	74.00	Pass
17895.00	44.97	PK	V	-6.54	38.43	74.00	Pass	

Remark:

Factor = Antenna Factor + Cable Loss – Pre-amplifier.

Emission Level = Meter Reading + Factor

Margin = Emission Level - Limit

Other harmonics emissions are lower than 20dB below the allowable limit.



4. BANDWIDTH TEST

4.1 APPLIED PROCEDURES / LIMIT

FCC Part15 (15.249) , Subpart C				
Section	Test Item	Limit	Frequency Range (MHz)	Result
15.249	Bandwidth	(20dB bandwidth)	2400-2483.5	PASS

Spectrum Parameter	Setting
Attenuation	Auto
Span Frequency	> Measurement Bandwidth or Channel Separation
RB	30KHz
VB	100KHz
Detector	Peak
Trace	Max Hold
Sweep Time	Auto

4.1.1 TEST PROCEDURE

- a. The EUT was directly connected to the spectrum analyzer and antenna output port as show in the block diagram below,
- b. Spectrum Setting : RBW= 30KHz, VBW≥ RBW, Sweep time = Auto.

4.1.2 DEVIATION FROM STANDARD

No deviation.

4.1.3 TEST SETUP

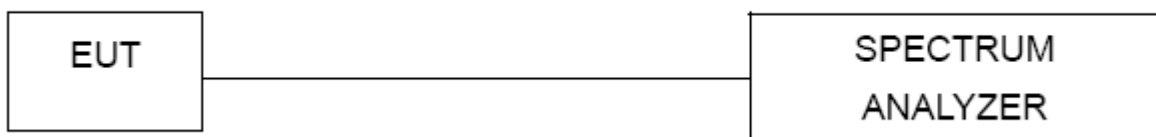

4.1.4 EUT OPERATION CONDITIONS

The EUT tested system was configured as the statements of 2.4 Unless otherwise a special operating condition is specified in the follows during the testing.



4.1.5 TEST RESULTS

EUT :	Speaker Box	Model Name :	PP-36215AUES
Temperature :	25 °C	Relative Humidity :	60%
Pressure :	1012 hPa	Test Voltage :	AC120V/60Hz
Test Mode :	CH01 / CH20 /CH78		

	Frequency	20dB Bandwidth (MHz)	Result
GFSK	2402 MHz	0.626	PASS
	2441 MHz	0.648	PASS
	2480 MHz	0.673	PASS
PI/4 DPSK	2402 MHz	1.219	PASS
	2441 MHz	1.213	PASS
	2480 MHz	1.204	PASS
8DPSK	2402 MHz	1.235	PASS
	2441 MHz	1.239	PASS
	2480 MHz	1.217	PASS

GFSK

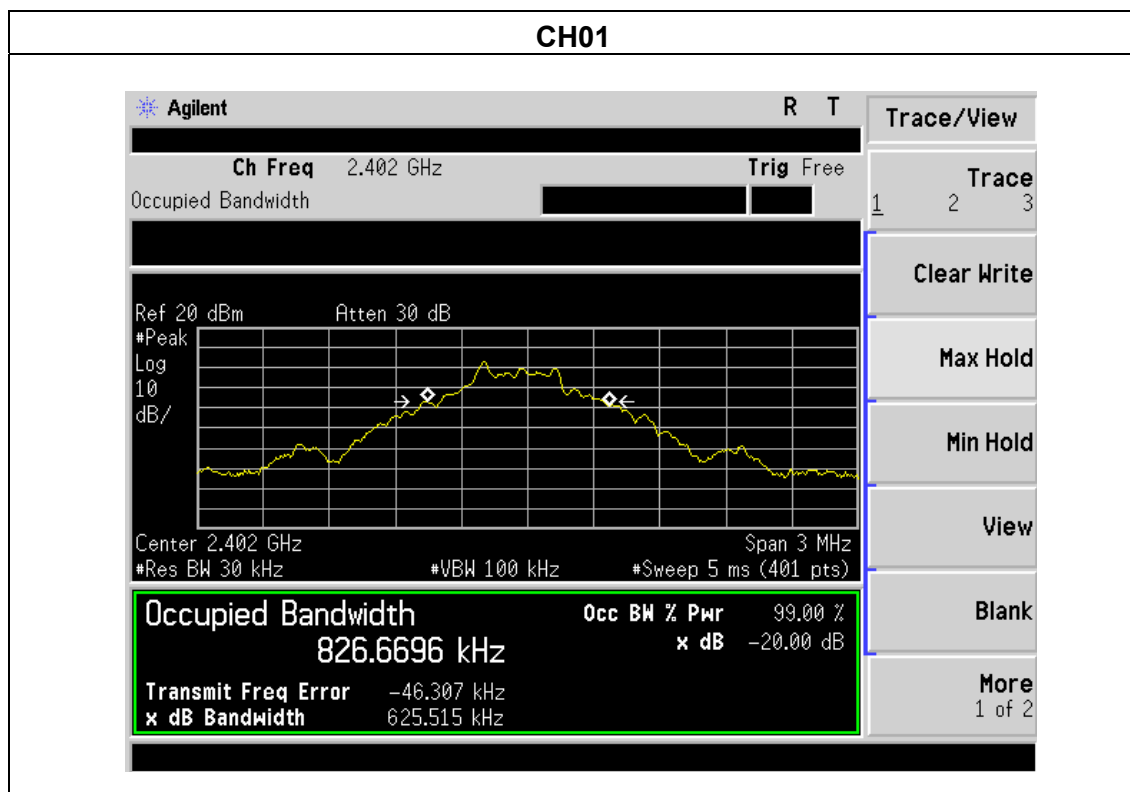

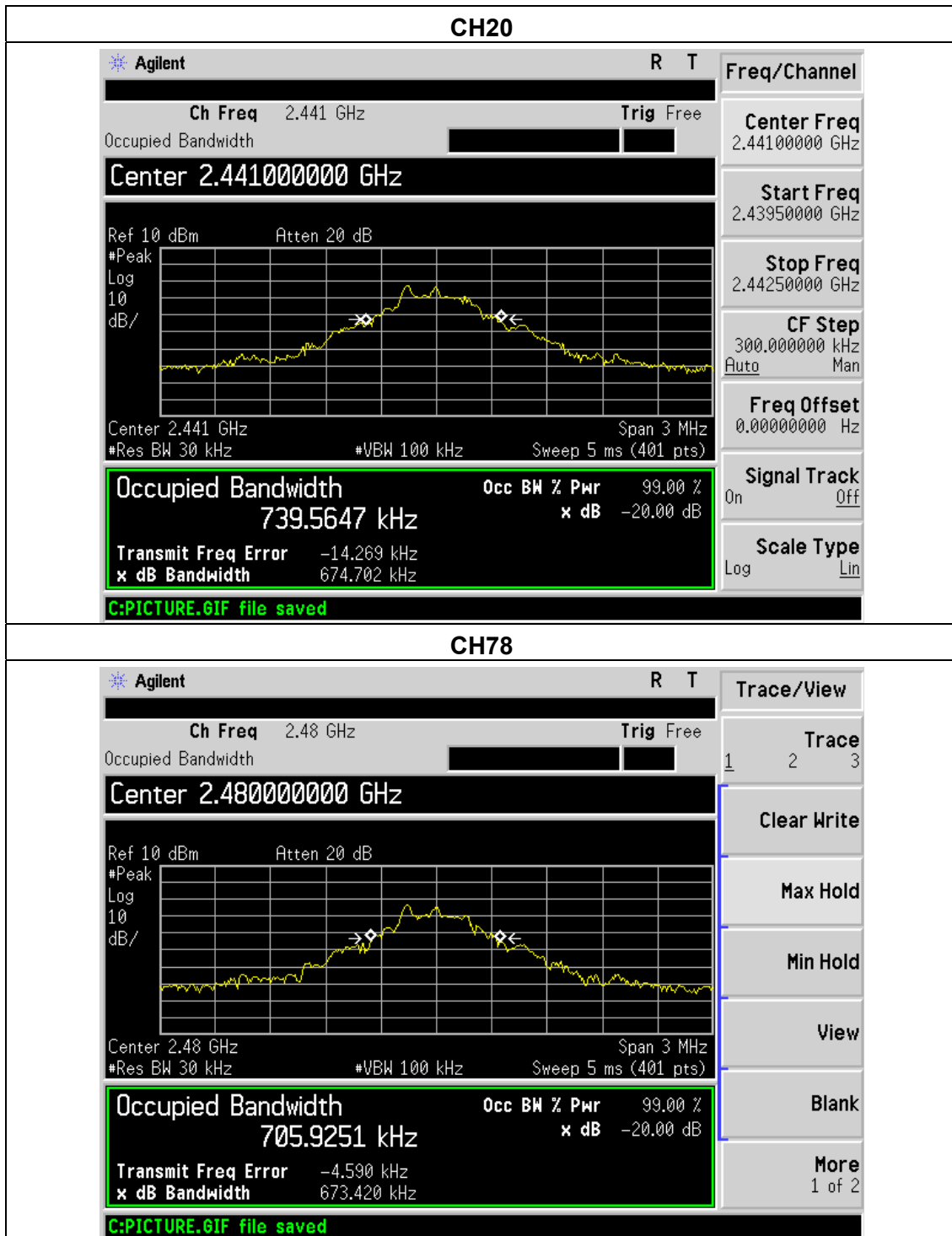



8DPSK

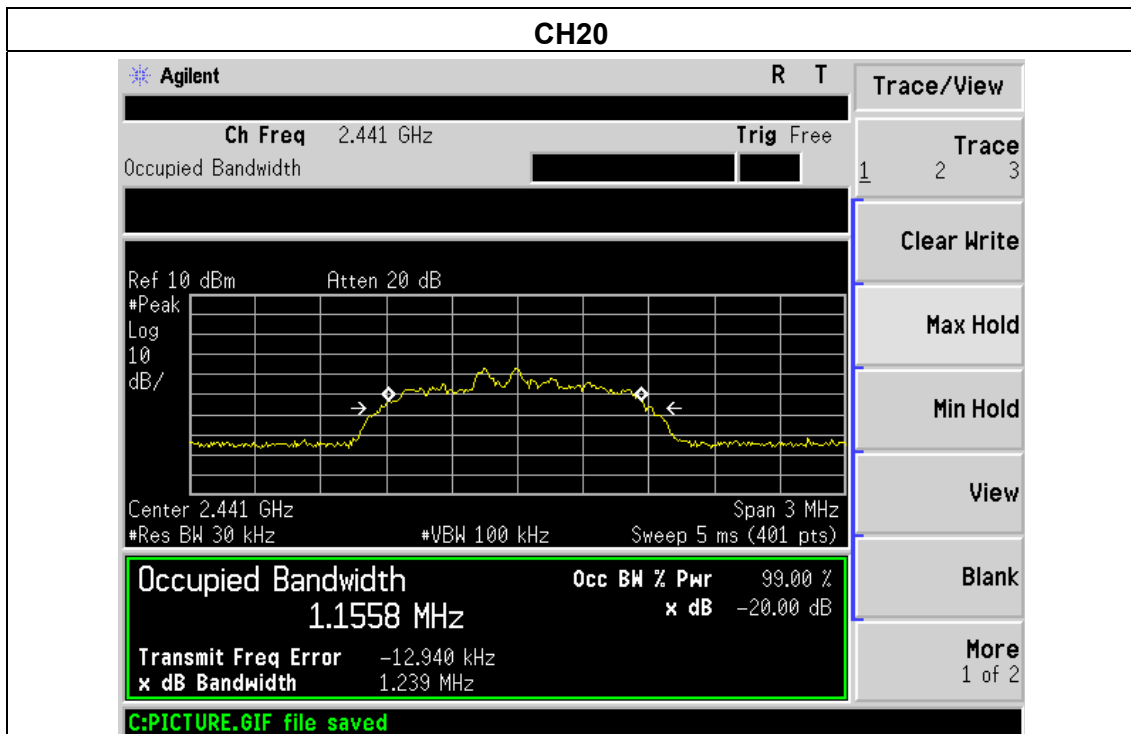
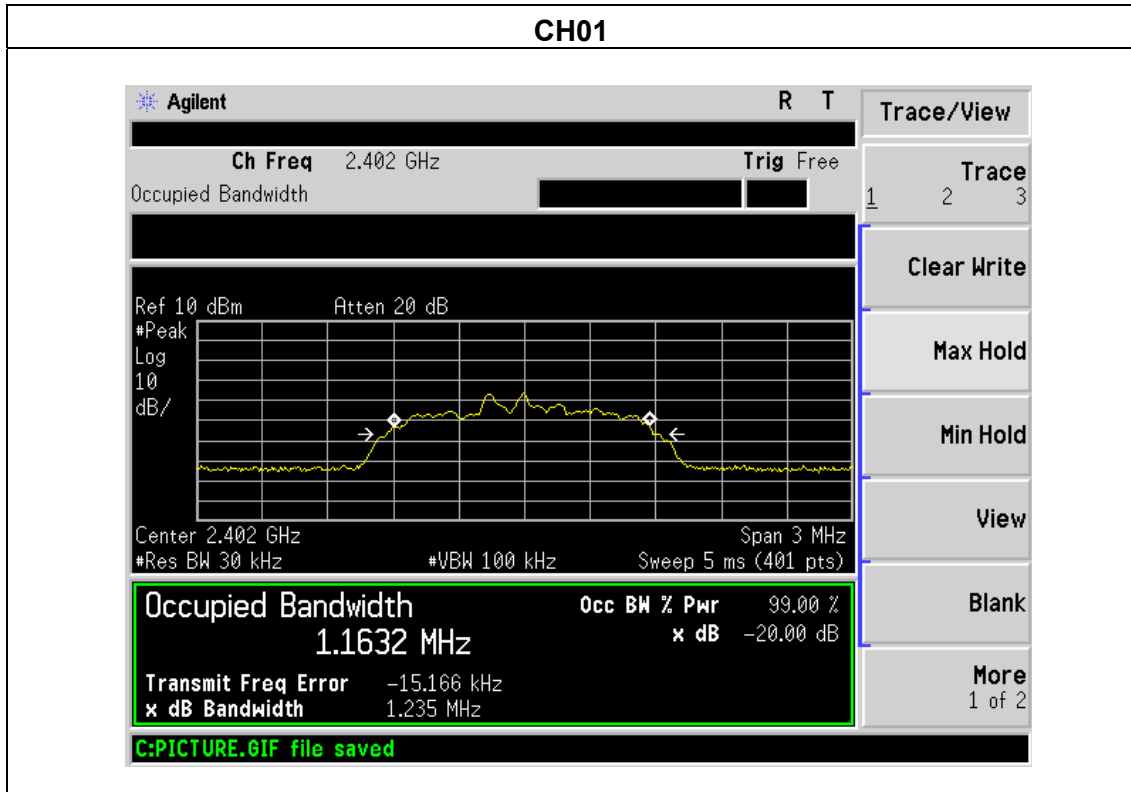

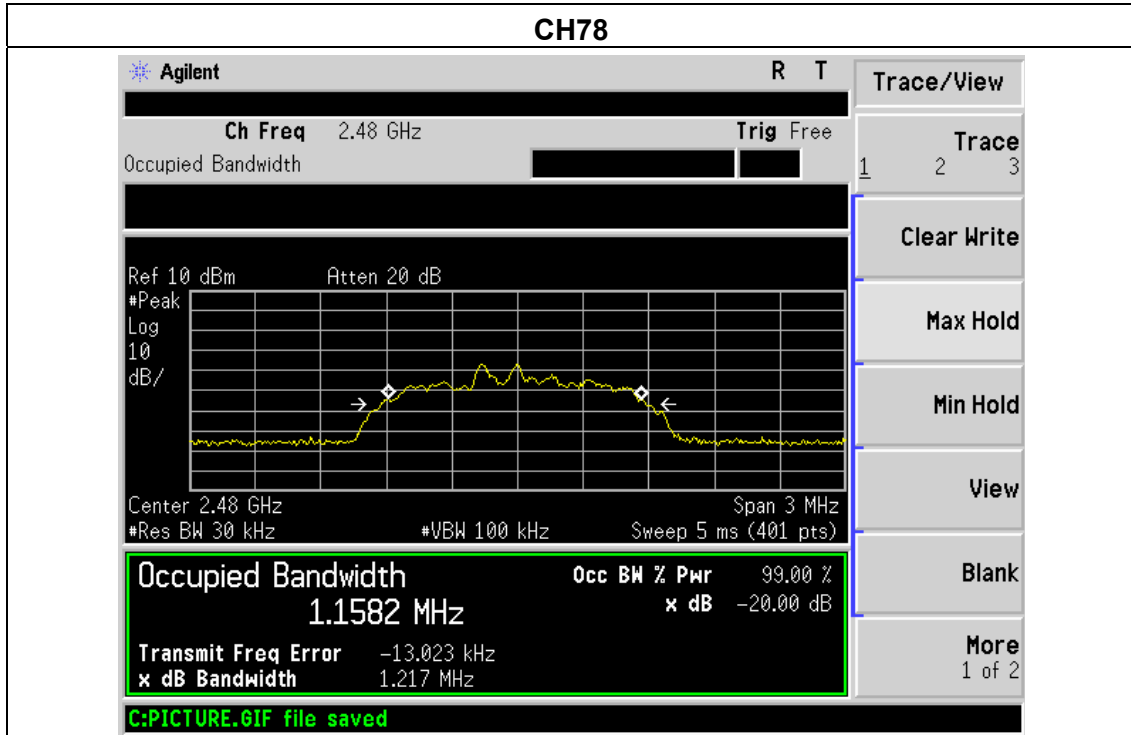



5. 100 KHZ BANDWIDTH OF FREQUENCY BAND EDGE APPLICABLE STANDARD

In any 100 kHz bandwidth outside the frequency band in which the spread spectrum or digitally modulated intentional radiator is operating, the radio frequency power that is produced by the intentional radiator shall be at least 20 dB below that in the 100 kHz bandwidth within the band that contains the highest level of the desired power, based on either an RF conducted or a radiated measurement, provided the transmitter demonstrates compliance with the peak conducted power limits. If the transmitter complies with the conducted power limits based on the use of RMS averaging over a time interval, as permitted under paragraph (b)(3) of this section, the attenuation required under this paragraph shall be 30 dB instead of 20 dB. Attenuation below the general limits specified in §15.209(a) is not required. In addition, radiated emissions which fall in the restricted bands, as defined in §15.205(a), must also comply with the radiated emission limits specified in §15.209(a) (see §15.205(c)).

TEST PROCEDURE

The testing follows ANSI C63.10-2013 clause 7.8.6.

The RF output of EUT was connected to the spectrum analyzer by RF cable and attenuator.

The path loss was compensated to the results for each measurement.

Set to the maximum power setting and enable the EUT transmit continuously.

The EUT must have its hopping function enabled.

Use the following spectrum analyzer settings:

Span = approximately 5 times the 20 dB bandwidth, centered on a hopping channel

RBW = 100KHz

VBW = 300KHz

Band edge emissions must be at least 20 dB down from the highest emission level within the authorized band as measured with a 100kHz RBW. The attenuation shall be 30 dB instead of 20 dB when RMS conducted output power procedure is used.

Measure the highest amplitude appearing on spectral display and set it as a reference level. Plot the graph with marking the highest point and edge frequency.

Repeat above procedures until all measured frequencies were complete.

The worst mode on horizontal, the data only show worst mode.

Note:

Both horizontal and vertical antenna polarities were tested

and performed pretest to three orthogonal axis. The worst case emissions were reported

5.1 DEVIATION FROM STANDARD

No deviation.

5.2 EUT OPERATION CONDITIONS

The EUT tested system was configured as the statements of 2.4 Unless otherwise a special operating condition is specified in the follows during the testing.

5.3 TEST RESULTS



GFSK:

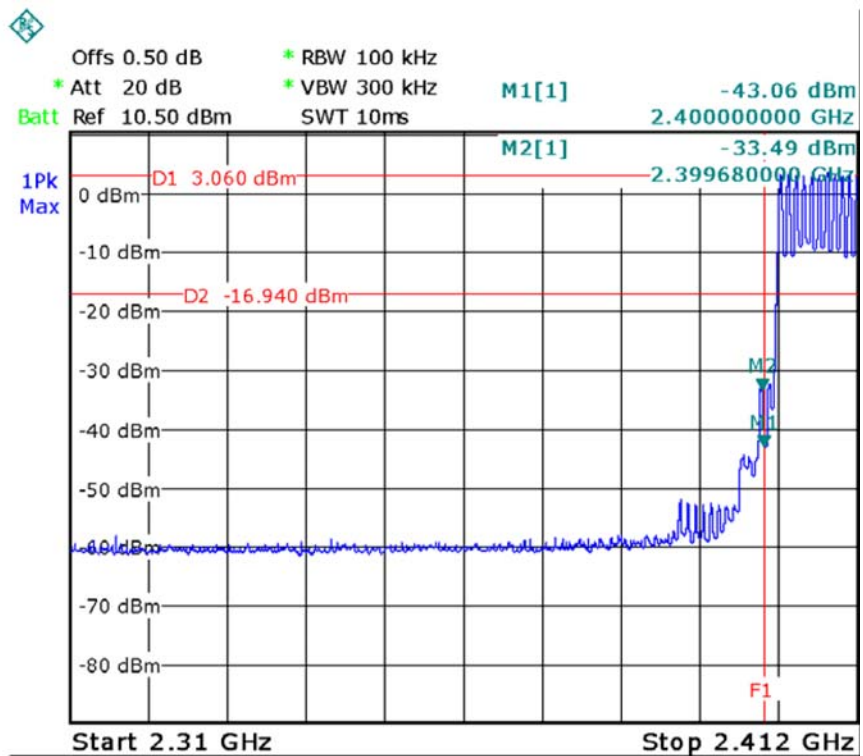
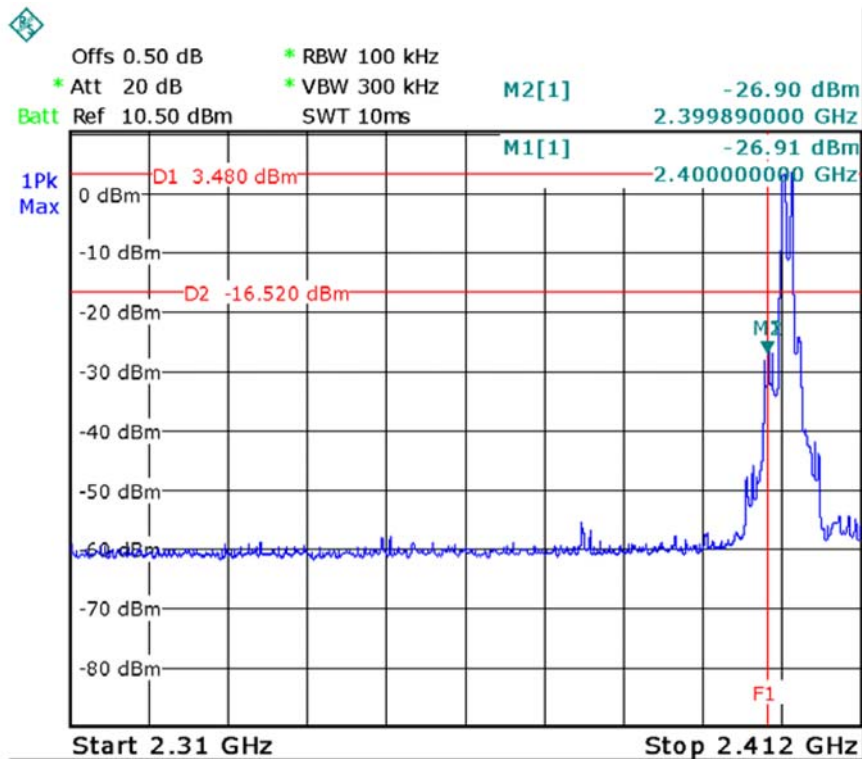

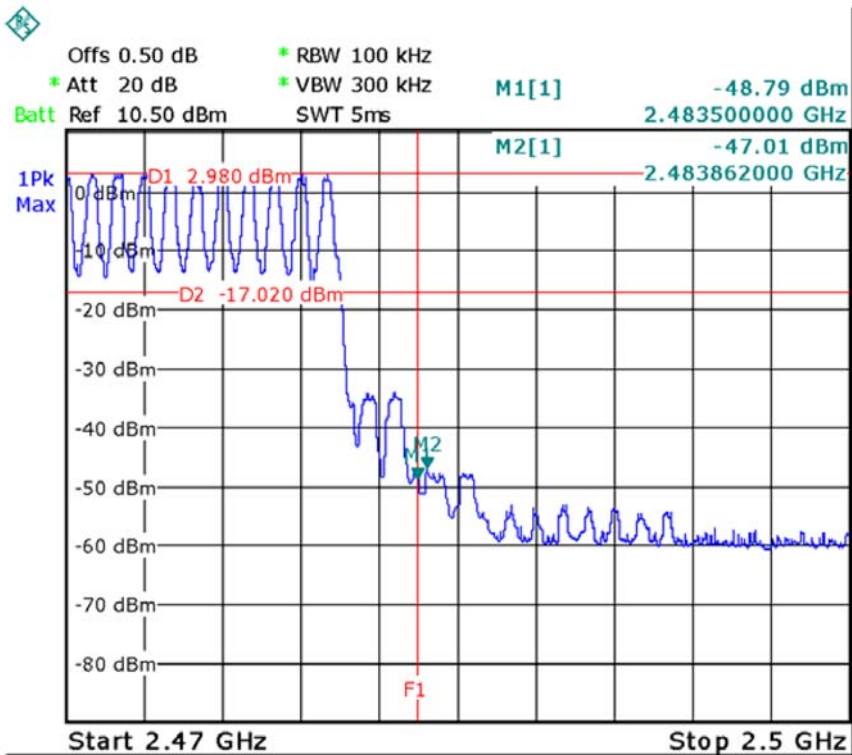
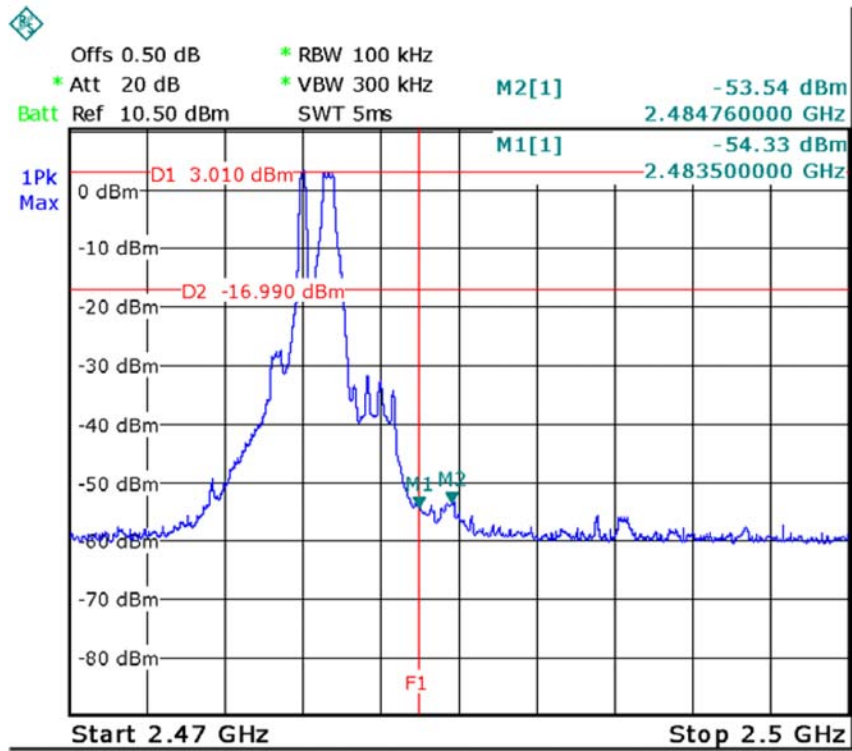



PI/4 DPSK

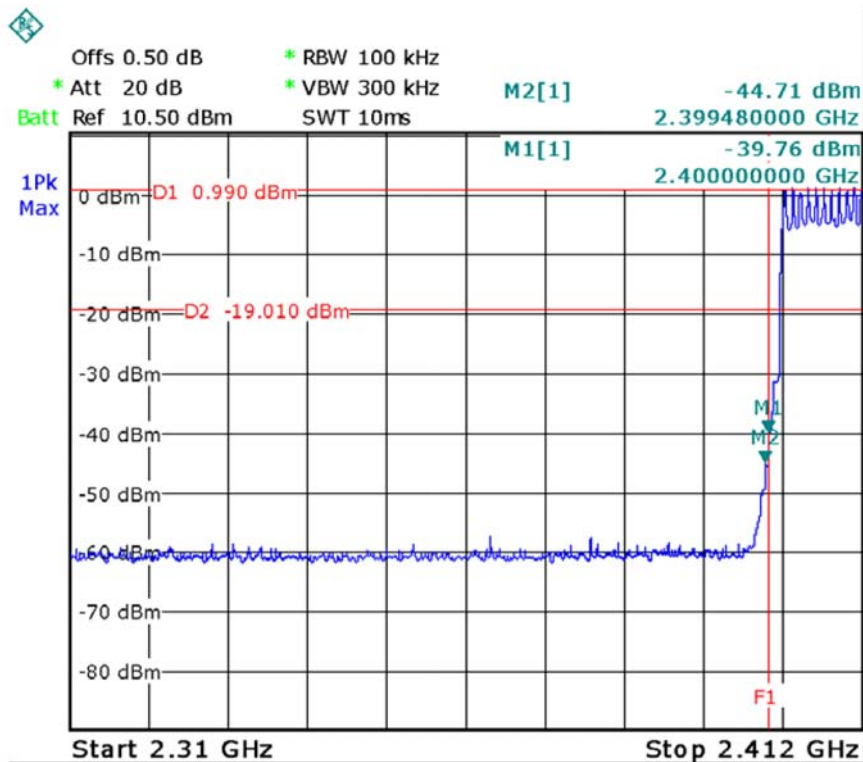
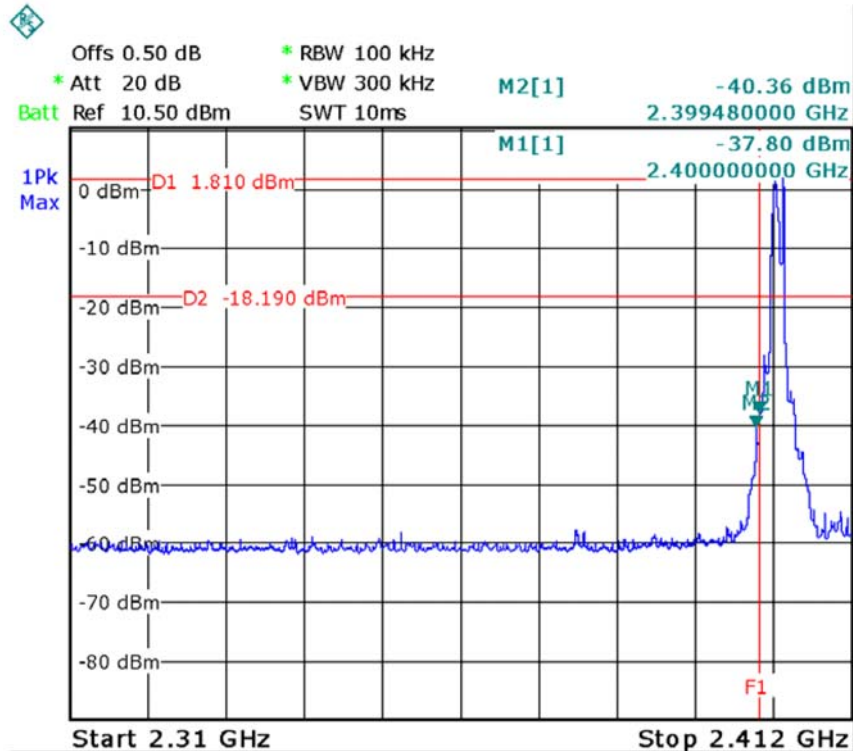

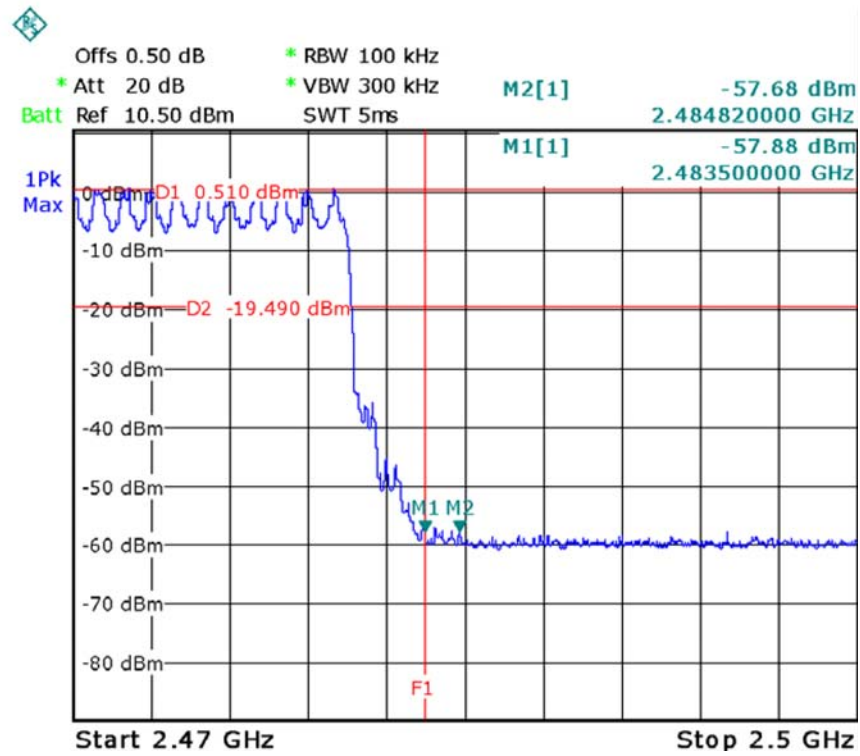
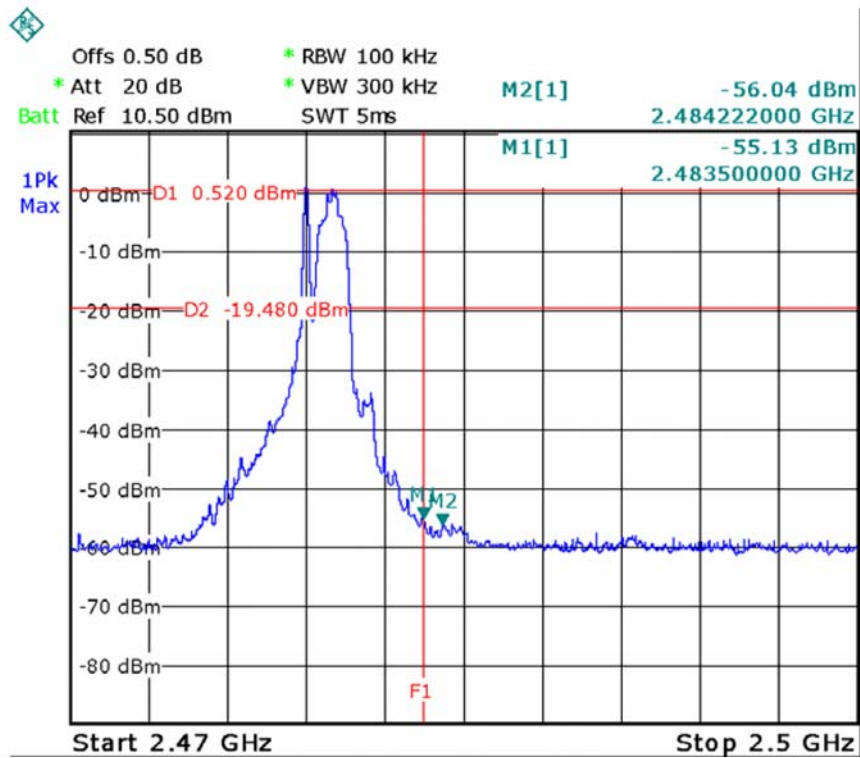



8DPSK

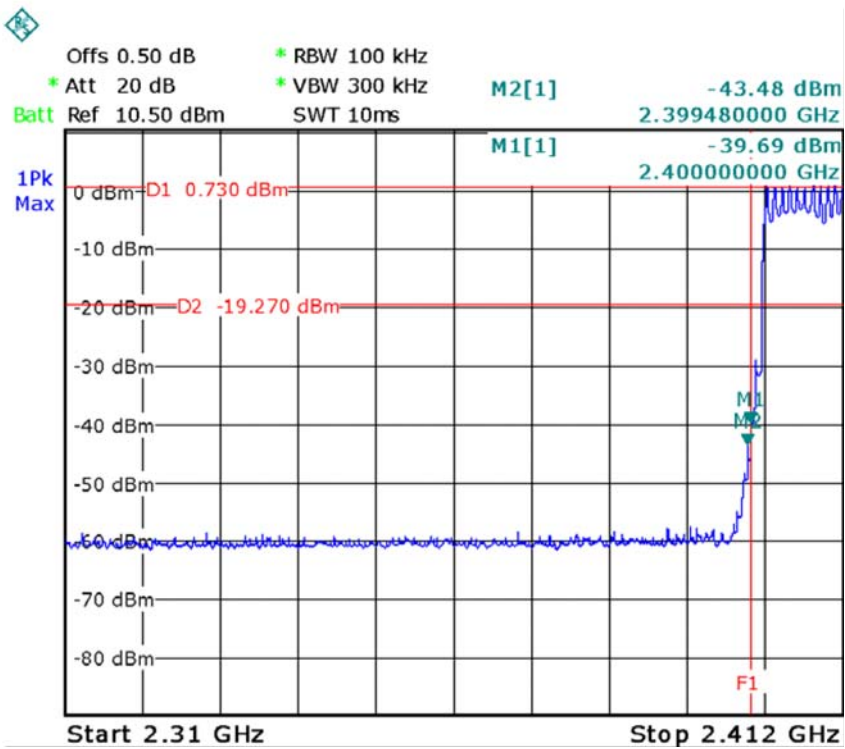
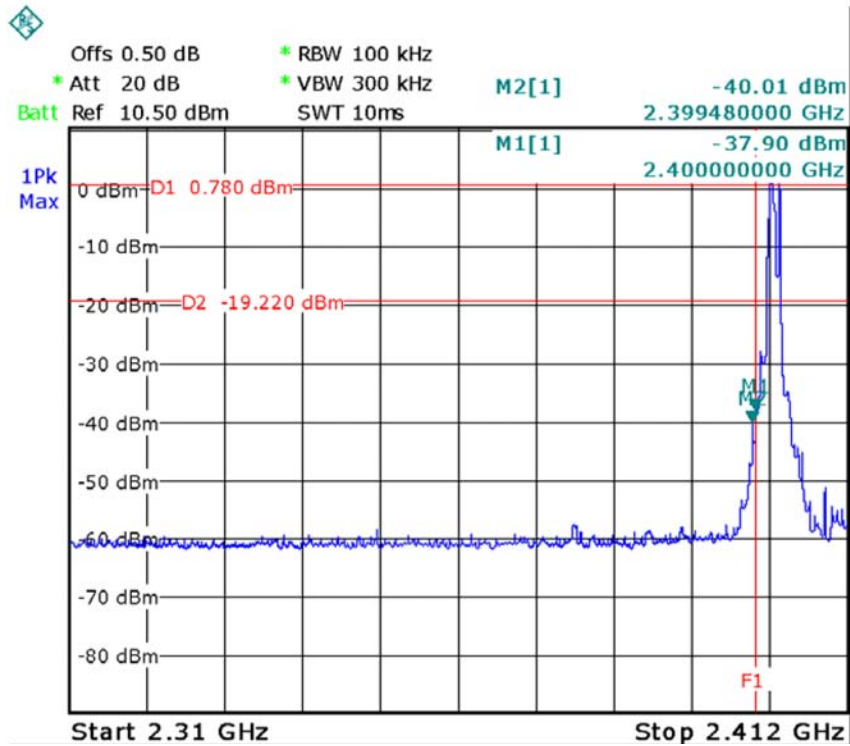

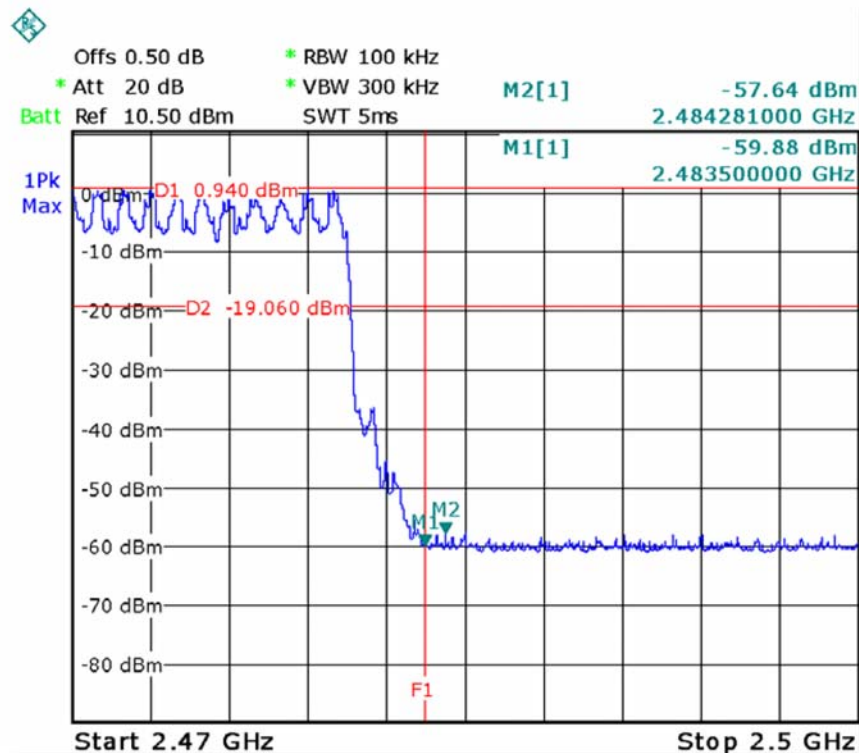
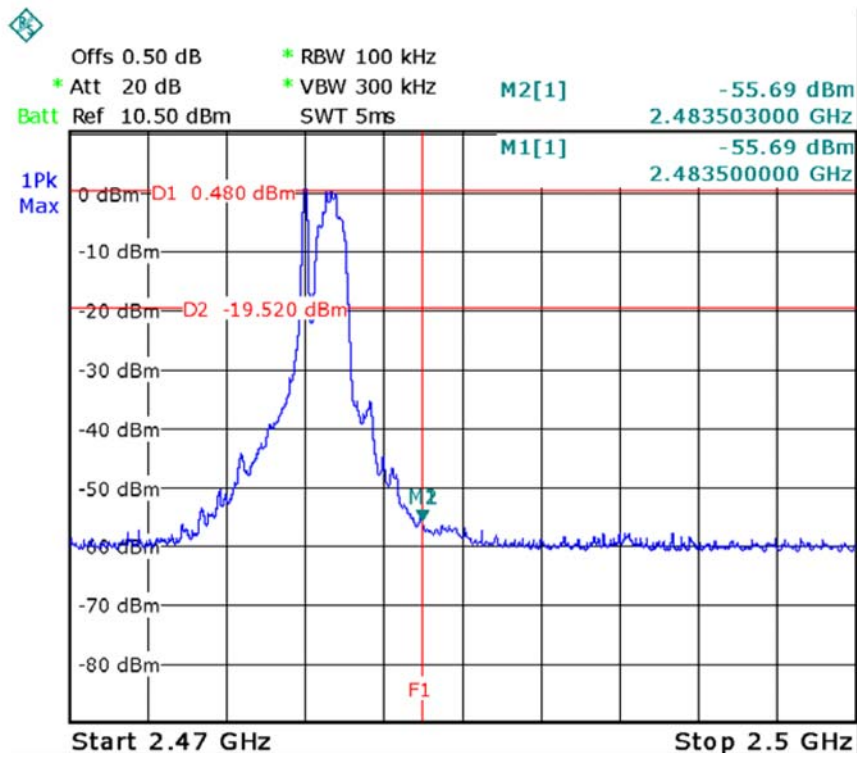



GFSK

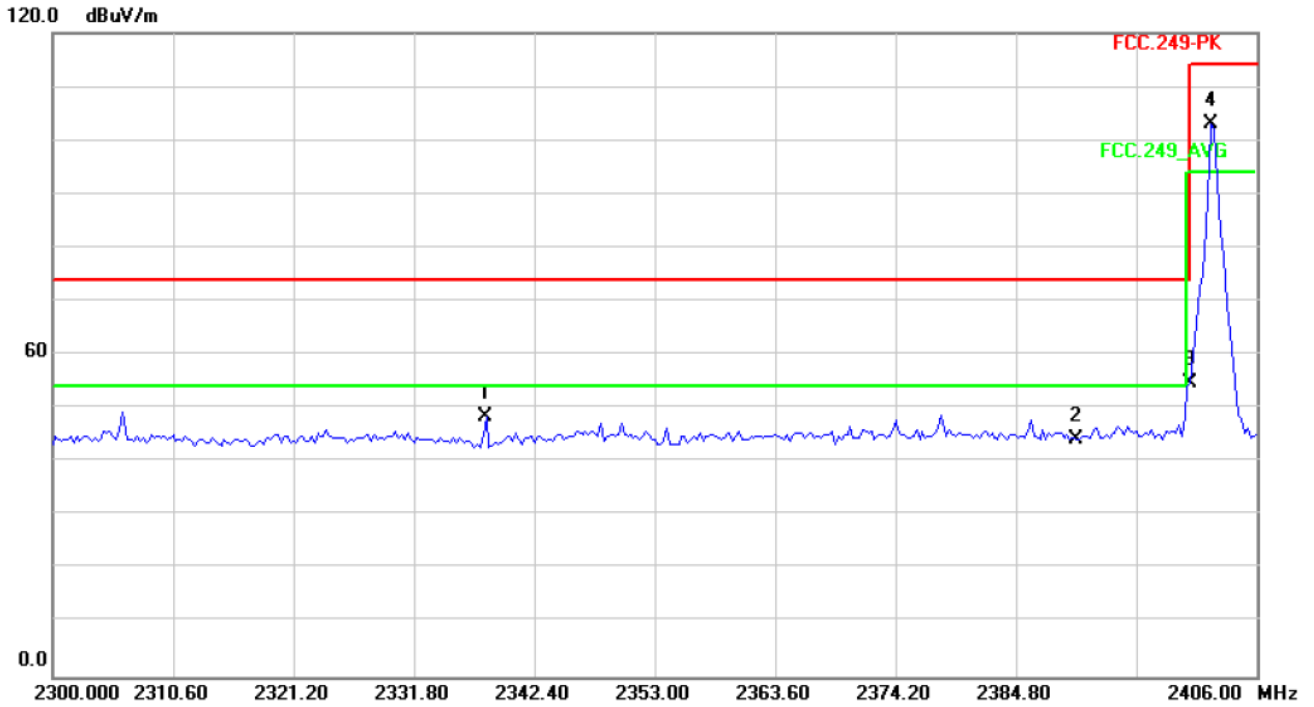

No.	Mk.	Freq. MHz	Reading Level dBuV	Correct Factor dB/m	Measure- ment dBuV/m	Limit dBuV/m	Over dB	Detector	Antenna Height cm	Table Degree degree	Comment
1		2338.160	34.71	13.73	48.44	74.00	-25.56	peak			
2		2390.100	30.41	13.83	44.24	74.00	-29.76	peak			
3		2400.170	40.84	13.85	54.69	114.00	-59.31	peak			
4	*	2402.025	89.10	13.85	102.95	114.00	-11.05	peak			

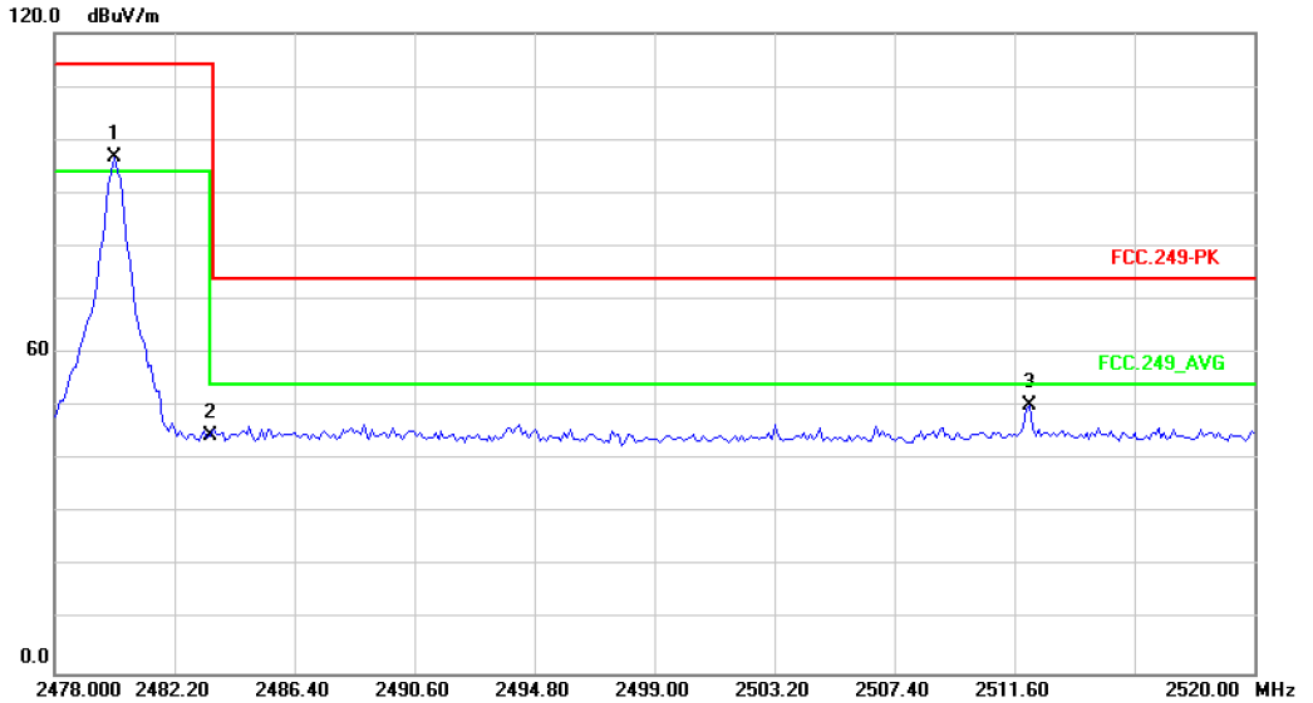

No.	Mk.	Freq.	Reading Level	Correct Factor	Measurement	Limit	Over	Antenna Height	Table Degree	Comment
		MHz	dBuV	dB/m	dBuV/m	dBuV/m	dB	cm	degree	
1	*	2480.100	82.59	14.02	96.61	114.00	-17.39	peak		
2		2483.460	30.48	14.02	44.50	114.00	-69.50	peak		
3		2512.125	36.27	14.08	50.35	74.00	-23.65	peak		

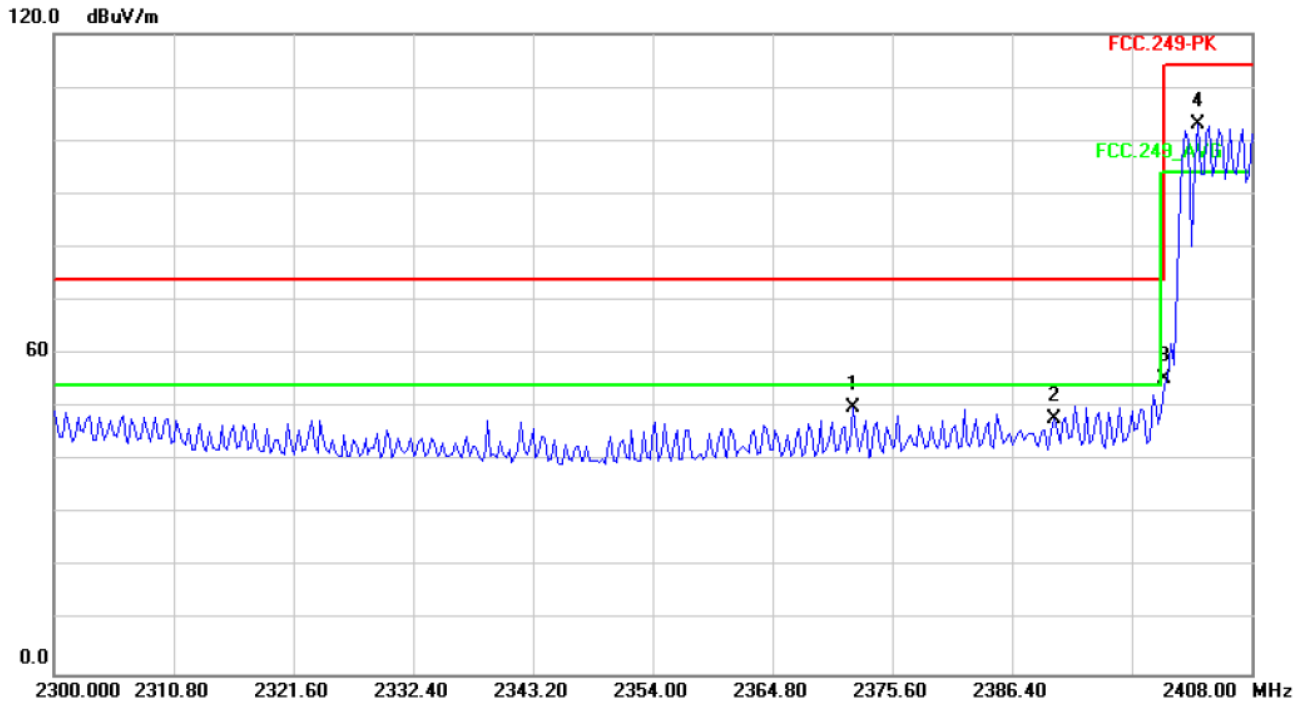

No. Mk.	Freq. MHz	Reading Level dBuV	Correct Factor dB/m	Measure- ment dBuV/m	Limit dBuV/m	Over dB	Detector	Antenna Height cm	Table Degree degree	Comment
1	2372.090	36.26	13.79	50.05	74.00	-23.95	peak			
2	2390.180	33.91	13.83	47.74	74.00	-26.26	peak			
3	2400.170	41.36	13.85	55.21	114.00	-58.79	peak			
4 *	2403.140	89.28	13.87	103.15	114.00	-10.85	peak			

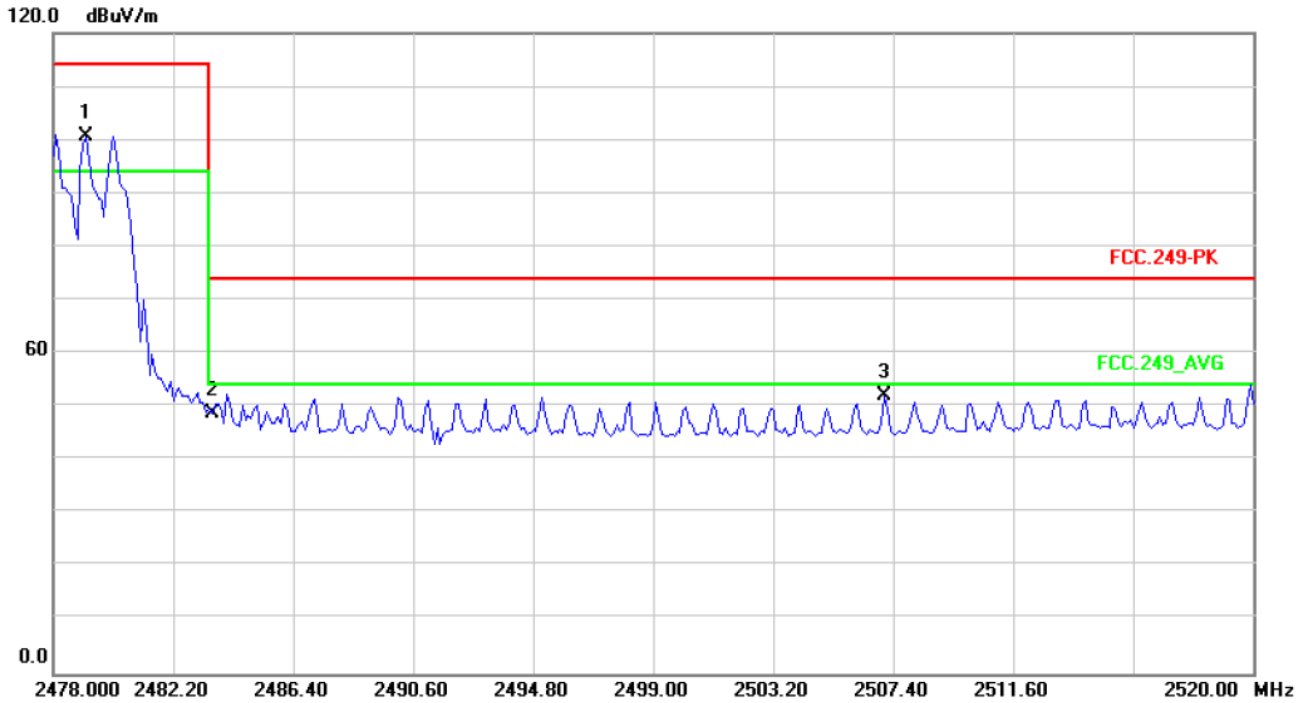

No.	Mk.	Freq.	Reading Level	Correct Factor	Measurement	Limit	Over	Antenna Height	Table Degree	
		MHz	dBuV	dB/m	dBuV/m	dBuV/m	dB	cm	degree	Comment
1	*	2479.155	86.65	14.02	100.67	114.00	-13.33	peak		
2		2483.565	34.86	14.02	48.88	74.00	-25.12	peak		
3		2507.085	37.84	14.08	51.92	74.00	-22.08	peak		



8DPSK

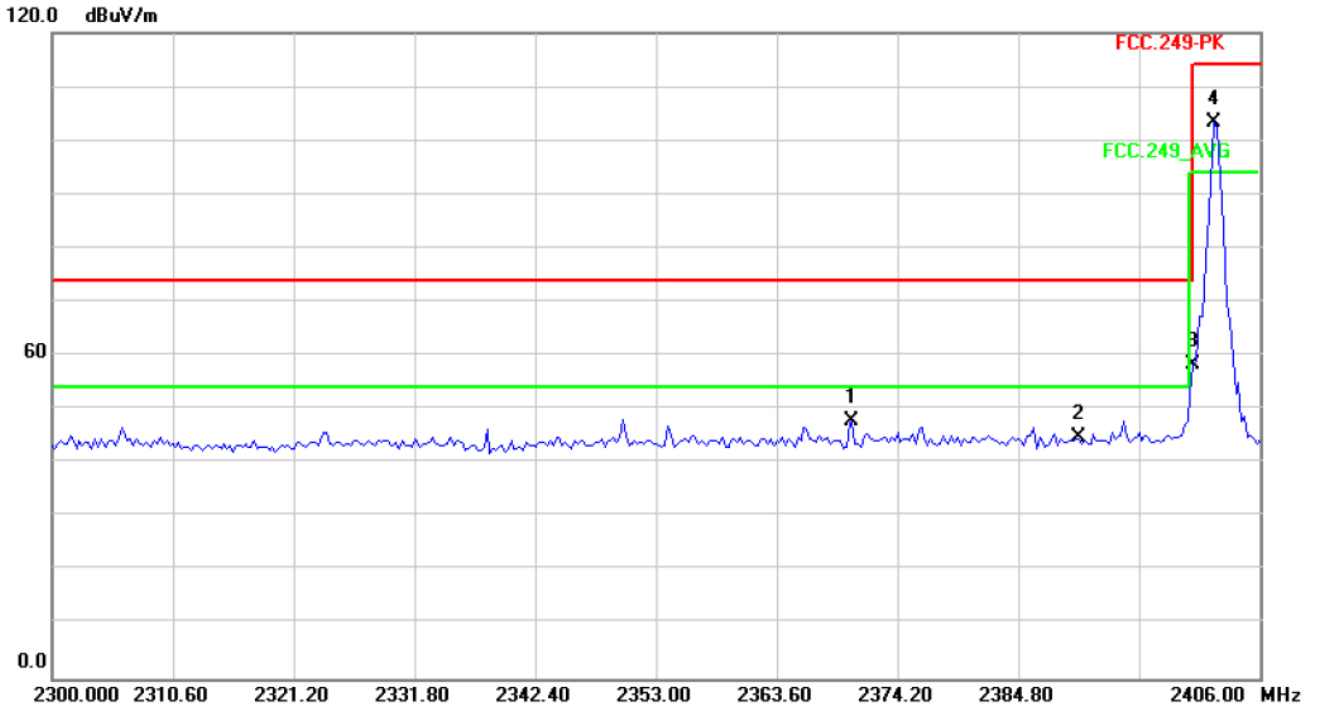

No.	Mk.	Freq. MHz	Reading Level dBuV	Correct Factor dB/m	Measure- ment dBuV/m	Limit dBuV/m	Over dB	Detector	Antenna Height cm	Table Degree degree	Comment
1		2370.225	33.96	13.79	47.75	74.00	-26.25	peak			
2		2390.100	30.87	13.83	44.70	74.00	-29.30	peak			
3		2400.170	44.63	13.85	58.48	114.00	-55.52	peak			
4	*	2402.025	89.64	13.85	103.49	114.00	-10.51	peak			

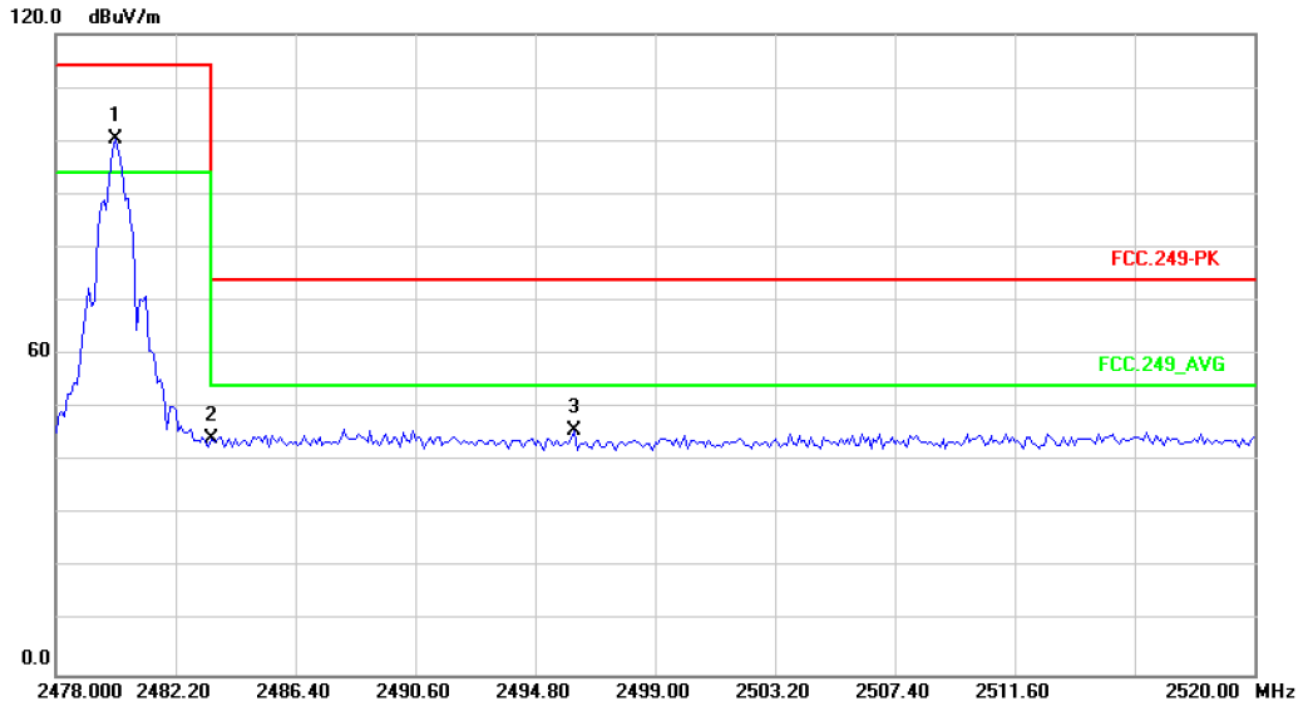

No.	Mk.	Freq.	Reading Level	Correct Factor	Measurement	Limit	Over	Antenna Height	Table Degree	
		MHz	dBuV	dB/m	dBuV/m	dBuV/m	dB	cm	degree	Comment
1	*	2480.100	86.21	14.02	100.23	114.00	-13.77	peak		
2		2483.460	30.12	14.02	44.14	114.00	-69.86	peak		
3		2496.165	31.65	14.06	45.71	74.00	-28.29	peak		

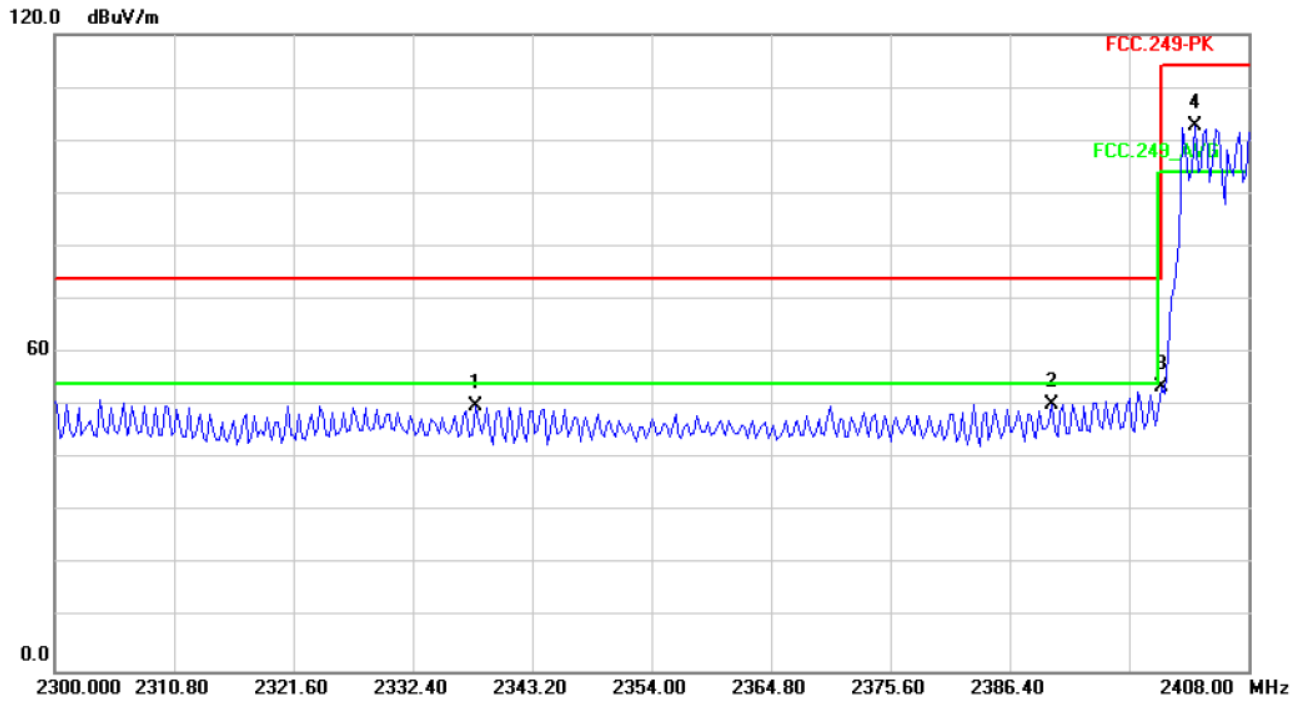

No.	Mk.	Freq.	Reading Level	Correct Factor	Measurement	Limit	Over	Antenna Height	Table Degree	
		MHz	dBuV	dB/m	dBuV/m	dBuV/m	dB	cm	degree	Comment
1		2338.070	36.25	13.71	49.96	74.00	-24.04			peak
2		2390.180	36.46	13.83	50.29	74.00	-23.71			peak
3		2400.170	39.60	13.85	53.45	114.00	-60.55			peak
4	*	2403.140	88.78	13.87	102.65	114.00	-11.35			peak

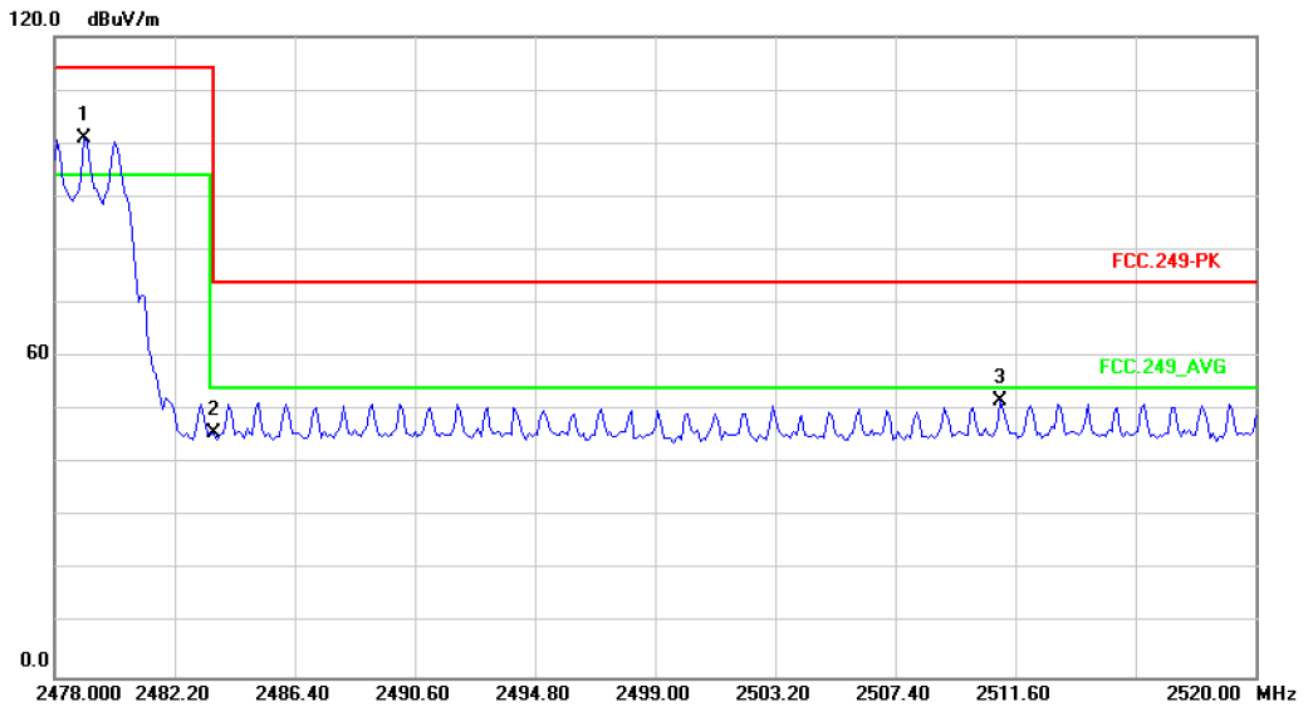

No.	Mk.	Freq.	Reading Level	Correct Factor	Measurement	Limit	Over	Antenna Height	Table Degree	
		MHz	dBuV	dB/m	dBuV/m	dBuV/m	dB	cm	degree	Comment
1	*	2479.050	86.92	14.02	100.94	114.00	-13.06			peak
2		2483.565	31.78	14.02	45.80	74.00	-28.20			peak
3		2511.075	37.78	14.08	51.86	74.00	-22.14			peak



6. ANTENNA REQUIREMENT

6.1 STANDARD REQUIREMENT

15.203 requirement: For intentional device, according to 15.203: an intentional radiator shall be designed to ensure that no antenna other than that furnished by the responsible party shall be used with the device.

6.2 EUT ANTENNA

The EUT antenna is PCB antenna. It complies with the standard requirement.

7. EUT TEST PHOTO

Conducted Measurement Photos



Radiated Measurement Photos

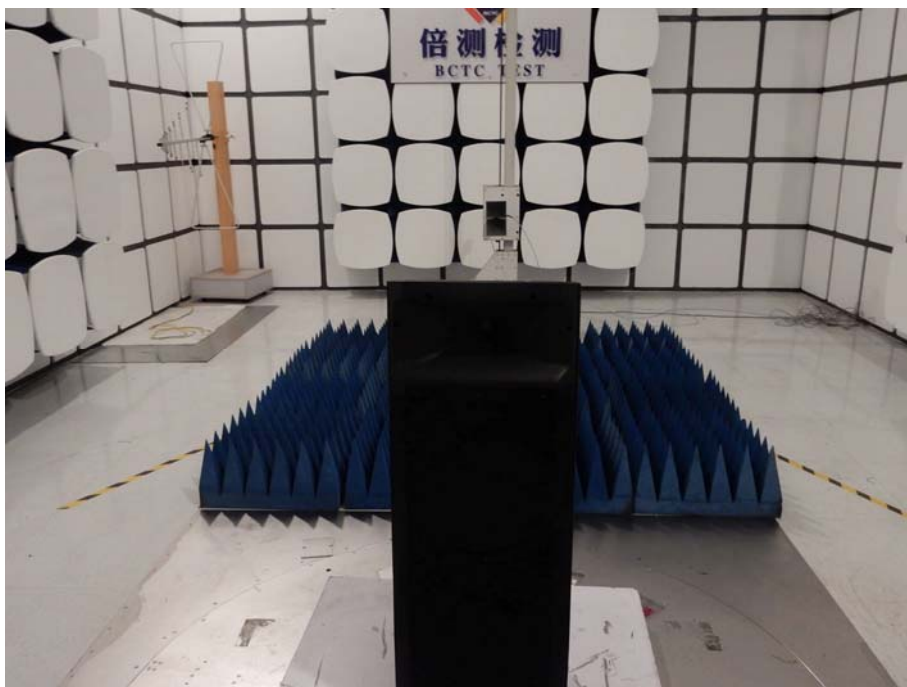
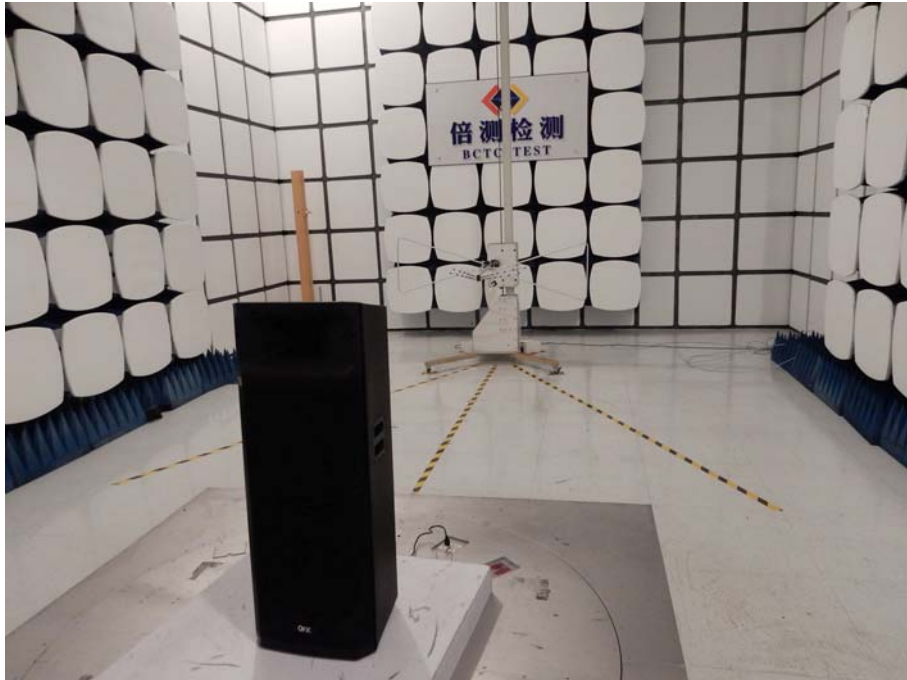

8. PHOTOS OF THE EUT



