

Test Report

FCC ID:2AHU8-1241

Product Name:	microphone
Trademark:	N/A
Model Name :	MIC-U1
Prepared For :	Ningbo Polinata Electronics Co., Ltd.
Address :	LongXing Village WuXiang Town Yinzhou District, NingBo,China
Prepared By :	Shenzhen BCTC Testing Co., Ltd.
Address :	BCTC Building & 1-2F, East of B Building, Pengzhou Industrial, Fuyuan 1st Road, Qiaotou Community, Fuyong Street, Bao'an District, Shenzhen, China
Test Date:	Dec. 27, 2019 to May 20, 2020
Date of Report :	May 20, 2020
Report No.:	BCTC1912001333-1E

TEST RESULT CERTIFICATION

Applicant's name : Ningbo Polinata Electronics Co., Ltd.
Address : LongXing Village WuXiang Town Yinzhou District,
NingBo,China

Manufacture's Name..... : Ningbo Polinata Electronics Co., Ltd.
Address : LongXing Village WuXiang Town Yinzhou District,
NingBo,China

Product description

Product name : microphone
Trademark : N/A
Model and/or type reference : MIC-U1

Standards : FCC Part 15.236

This device described above has been tested by BCTC, and the test results show that the equipment under test (EUT) is in compliance with the FCC requirements. And it is applicable only to the tested sample identified in the report.

This report shall not be reproduced except in full, without the written approval of BCTC, this document may be altered or revised by BCTC, personal only, and shall be noted in the revision of the document.

Prepared by(Engineer): Cai Fangzhong

Cai Fang Zhong

Reviewer(Supervisor): Eric Yang

Eric Yang

Approved(Manager): Zero Zhou

Zero Zhou



	Page
1 . SUMMARY OF TEST RESULTS	5
1.1 TEST FACILITY	6
1.2 MEASUREMENT UNCERTAINTY	6
2 . GENERAL INFORMATION	7
2.1 GENERAL DESCRIPTION OF EUT	7
2.2 DESCRIPTION OF TEST MODES	8
2.3 BLOCK DIGRAM SHOWING THE CONFIGURATION OF SYSTEM TESTED	8
2.4 DESCRIPTION OF SUPPORT UNITS(CONDUCTED MODE)	9
2.5 EQUIPMENTS LIST FOR ALL TEST ITEMS	10
3 . EMC EMISSION TEST	11
3.1 CONDUCTED EMISSION MEASUREMENT	11
3.1.1 POWER LINE CONDUCTED EMISSION LIMITS	11
3.1.2 TEST PROCEDURE	11
3.1.3 DEVIATION FROM TEST STANDARD	11
3.1.4 TEST SETUP	12
3.1.5 EUT OPERATING CONDITIONS	12
3.1.6 TEST RESULTS	12
3.2 RADIATED SPURIOUS EMISSIONS	13
3.2.1 TEST REQUIREMENT	13
3.2.2 TEST PROCEDURE	14
3.2.3 DEVIATION FROM TEST STANDARD	14
3.2.4 TEST SETUP	15
3.2.5 EUT OPERATING CONDITIONS	16
3.2.6 TEST RESULTS (BETWEEN 9KHZ – 30 MHZ)	17
3.2.7 TEST RESULTS (BETWEEN 30MHZ – 1GHZ)	18
4 . RF OUTPUT POWER	21
4.1 TEST REQUIREMENT:	21
4.1.1 TEST PROCEDURE	21
4.1.2 DEVIATION FROM STANDARD	21
4.1.3 TEST SETUP	21
4.1.4 EUT OPERATION CONDITIONS	21
4.1.5 TEST RESULTS	21
5 . BANDWIDTH TEST & EMISSION MASK	22
5.1 APPLIED PROCEDURES / LIMIT	22



	Page
Table of Contents	
5.1.1 TEST PROCEDURE	22
5.1.2 DEVIATION FROM STANDARD	24
5.1.3 TEST SETUP	24
5.1.4 EUT OPERATION CONDITIONS	24
5.1.5 TEST RESULTS	25
6 . FREQUENCY STABILITY	27
6.1 APPLICABLE STANDARD	27
6.2 TEST PROCEDURE	27
6.3 DEVIATION FROM STANDARD	27
6.4 TEST SETUP	27
6.5 EUT OPERATION CONDITIONS	27
7 . ANTENNA REQUIREMENT	29
7.1 STANDARD REQUIREMENT	29
7.2 EUT ANTENNA	29
8 . EUT TEST PHOTO	30
9 . EUT PHOTO	31
APPENDIX-PHOTOGRAPHS OF EUT CONSTRUCTIONAL DETAILS	

1. SUMMARY OF TEST RESULTS

Test procedures according to the technical standards:

FCC Part15 (15.236) , Subpart C			
Standard Section	Test Item	Judgment	Remark
15.207	Conducted Emission	N/A	
15.236(d)(2)	Output Power Measurement	PASS	
15.236(f)(2)	Occupied Bandwidth Emission	PASS	
15.236(g)	Necessary Bandwidth	PASS	
15.236(g)	Radiated Spurious Emission	PASS	
15.236(f)(3)	Frequency Tolerance	PASS	
15.203	Antenna Requirement	PASS	

NOTE:

(1) "N/A" The EUT is powered by the Battery, the test item is not applicable.

1.1 TEST FACILITY

Shenzhen BCTC Testing Co., Ltd.

Add.: BCTC Building & 1-2F, East of B Building, Pengzhou Industrial, Fuyuan 1st Road, Qiaotou Community, Fuyong Street, Bao'an District, Shenzhen, China

FCC Test Firm Registration Number: 712850

IC Registered No.: 23583

1.2 MEASUREMENT UNCERTAINTY

The reported uncertainty of measurement $y \pm U$, where expanded uncertainty U is based on a standard uncertainty multiplied by a coverage factor of $k=2$, providing a level of confidence of approximately **95 %**.

No.	Item	Uncertainty
1	3m chamber Radiated spurious emission(30MHz-1GHz)	U=4.3dB
2	3m chamber Radiated spurious emission(1GHz-18GHz)	U=4.5dB
3	3m chamber Radiated spurious emission(18GHz-40GHz)	U=3.34dB
4	Conducted Adjacent channel power	U=1.38dB
5	Conducted output power uncertainty Above 1G	U=1.576dB
6	Conducted output power uncertainty below 1G	U=1.28dB
7	humidity uncertainty	U=5.3%
8	Temperature uncertainty	U=0.59 °C

2. GENERAL INFORMATION

2.1 GENERAL DESCRIPTION OF EUT

Equipment	microphone	
Trade Name	N/A	
Model Name	MIC-U1	
Model Difference	N/A	
Product Description	The EUT is a microphone	
	Operation Frequency:	657.2MHz
	Modulation Type:	FM
	Number Of Channel	1CH
	Antenna Designation:	Please see Note 3.
Based on the application, features, or specification exhibited in User's Manual, the EUT is considered as an ITE/Computing Device. More details of EUT technical specification, please refer to the User's Manual.		
Channel List	Please refer to the Note 2.	
Power Source	DC 3V	
Connecting I/O Port(s)	Please refer to the User's Manual	
Product SW/HW version	PSW: A1.1	
	PHW: V1.1	
Radio SW/HW version	RSW: V1.1	
	RHW:A1.1	
Test SW Version	V1.1	

Note:

1. For a more detailed features description, please refer to the manufacturer's specifications or the User's Manual.



2.

Channel List					
Channel	Frequency (MHz)	Channel	Frequency (MHz)	Channel	Frequency (MHz)
01	657.2	/	/	/	/

3.

Table for Internal Antenna

Ant.	Brand	Model Name	Antenna Type	Gain (dBi)
1	N/A	N/A	Internal antenna	1.15

2.2 DESCRIPTION OF TEST MODES

To investigate the maximum EMI emission characteristics generates from EUT, the test system was pre-scanning tested base on the consideration of following EUT operation mode or test configuration mode which possible have effect on EMI emission level. Each of these EUT operation mode(s) or test configuration mode(s) mentioned above was evaluated respectively.

Test Mode	Test mode	channel
Mode 1	Transmitting(FM)	657.2MHz

2.3 BLOCK DIGRAM SHOWING THE CONFIGURATION OF SYSTEM TESTED

Radiated Spurious Emission Test

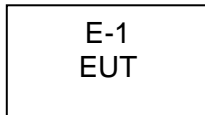



2.4 DESCRIPTION OF SUPPORT UNITS(CONDUCTED MODE)

The EUT has been tested as an independent unit together with other necessary accessories or support units. The following support units or accessories were used to form a representative test configuration during the tests.

No.	Device Type	Brand	Model	Series No.	Data Cable
E-1	microphone	N/A	MIC-U1	N/A	EUT

2.5 EQUIPMENTS LIST FOR ALL TEST ITEMS

Radiation Test equipment

Item	Equipment	Manufacturer	Type No.	Serial No.	Last calibration	Calibrated until
1	Spectrum Analyzer (9kHz-26.5GHz)	Agilent	E4407B	MY45109572	Jun. 13, 2019	Jun. 12, 2020
2	Test Receiver (9kHz-7GHz)	R&S	ESR7	101154	Jun. 13, 2019	Jun. 12, 2020
3	Bilog Antenna (30MHz-3GHz)	SCHWARZBECK	VULB9163	VULB9163-942	Jun. 22, 2019	Jun. 21, 2020
4	Horn Antenna (1GHz-18GHz)	SCHWARZBECK	BBHA9120D	1541	Jun. 22, 2019	Jun. 21, 2020
5	Horn Antenna (18GHz-40GHz)	SCHWARZBECK	BBHA9170	822	Jun. 22, 2019	Jun. 21, 2020
6	Amplifier (9KHz-6GHz)	SCHWARZBECK	BBV9744	9744-0037	Jun. 25, 2019	Jun. 24, 2020
7	Amplifier (0.5GHz-18GHz)	SCHWARZBECK	BBV9718	9718-309	Jun. 25, 2019	Jun. 24, 2020
8	Amplifier (18GHz-40GHz)	MITEQ	TTA1840-35-HG	2034381	Jun. 17, 2019	Jun. 16, 2020
9	Loop Antenna (9KHz-30MHz)	SCHWARZBECK	FMZB1519B	014	Jul. 02, 2019	Jul. 01, 2020
10	RF cables1 (9kHz-30MHz)	Huber+Suhnar	9kHz-30MHz	B1702988-0008	Jun. 25, 2019	Jun. 24, 2020
11	RF cables2 (30MHz-1GHz)	Huber+Suhnar	30MHz-1GHz	1486150	Jun. 25, 2019	Jun. 24, 2020
12	RF cables3 (1GHz-40GHz)	Huber+Suhnar	1GHz-40GHz	1607106	Jun. 25, 2019	Jun. 24, 2020
13	Power Metter	Keysight	E4419B	\	Jun. 17, 2019	Jun. 16, 2020
14	Power Sensor (AV)	Keysight	E9 300A	\	Jun. 17, 2019	Jun. 16, 2020
15	Signal Analyzer 20kHz-26.5GHz	KEYSIGHT	N9020A	MY49100060	Jun. 13, 2019	Jun. 12, 2020
16	Spectrum Analyzer 9kHz-40GHz	R&S	FSP40	100363	Jun. 13, 2019	Jun. 12, 2020
17	D.C. Power Supply	LongWei	TPR-6405D	\	\	\
18	Software	Frad	EZ-EMC	FA-03A2 RE	\	\

3. EMC EMISSION TEST

3.1 CONDUCTED EMISSION MEASUREMENT

3.1.1 POWER LINE CONDUCTED EMISSION Limits (Frequency Range 150KHz-30MHz)

FREQUENCY (MHz)	Limit (dBuV)		Standard
	Quasi-peak	Average	
0.15 -0.5	66 - 56 *	56 - 46 *	FCC
0.50 -5.0	56.00	46.00	FCC
5.0 -30.0	60.00	50.00	FCC

Note:

- (1) The tighter limit applies at the band edges.
- (2) The limit of " * " marked band means the limitation decreases linearly with the logarithm of the frequency in the range.

The following table is the setting of the receiver

Receiver Parameters	Setting
Attenuation	10 dB
Start Frequency	0.15 MHz
Stop Frequency	30 MHz
IF Bandwidth	9 kHz

3.1.2 TEST PROCEDURE

- a. The EUT was placed 0.8 meters from the horizontal ground plane with EUT being connected to the power mains through a line impedance stabilization network (LISN). All other support equipments powered from additional LISN(s). The LISN provide 50 Ohm/ 50uH of coupling impedance for the measuring instrument.
- b. Interconnecting cables that hang closer than 40 cm to the ground plane shall be folded back and forth in the center forming a bundle 30 to 40 cm long.
- c. I/O cables that are not connected to a peripheral shall be bundled in the center. The end of the cable may be terminated, if required, using the correct terminating impedance. The overall length shall not exceed 1 m.
- d. LISN at least 80 cm from nearest part of EUT chassis.
- e. For the actual test configuration, please refer to the related Item –EUT Test Photos.

3.1.3 DEVIATION FROM TEST STANDARD

No deviation

3.1.4 TEST SETUP

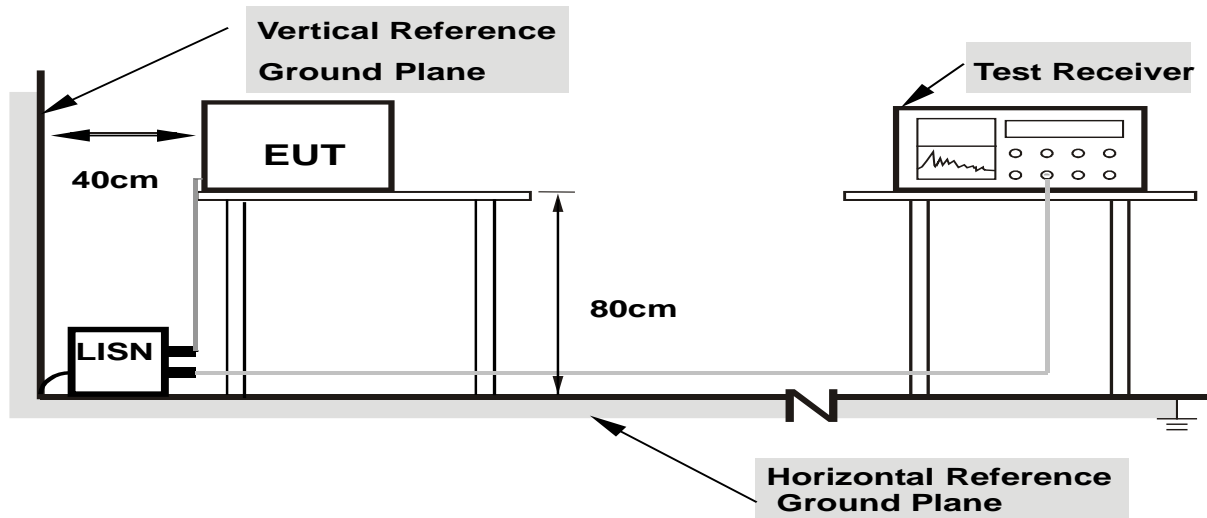

Note: 1.Support units were connected to second LISN.

2.Both of LISNs (AMN) are 80 cm from EUT and at least 80 from other units and other metal planes

3.1.5 EUT OPERATING CONDITIONS

The EUT was configured for testing in a typical fashion (as a customer would normally use it). The EUT has been programmed to continuously transmit during test. This operating condition was tested and used to collect the included data.

3.1.6 TEST RESULTS

NOTE: This EUT is powered by the battery only, this test item is not applicable.

3.2 RADIATED SPURIOUS EMISSIONS

3.2.1 TEST REQUIREMENT

According to FCC 15.236(g), Emission within the band from one megahertz below to one megahertz above the carrier frequency shall comply with the emission mask in Section 8.3 of ETSI EN 300 422-1 V1.4.2(2011-08). Emissions outside this band shall comply with the limit specified at the edges of the ETSI mask.

Table 3: Limits for spurious emissions

State	Frequency		
	47 MHz to 74 MHz 87,5 MHz to 137 MHz 174 MHz to 230 MHz 470 MHz to 862 MHz	Other Frequencies below 1 000 MHz	Frequencies above 1 000 MHz
Operation	4 nW	250 nW	1 μ W
Standby	2 nW	2 nW	20 nW

Receiver Parameter	Setting
Attenuation	Auto
Start ~ Stop Frequency	9kHz~150kHz / RB 200Hz for QP
Start ~ Stop Frequency	150kHz~30MHz / RB 9kHz for QP
Start ~ Stop Frequency	30MHz~1000MHz / RB 120kHz for QP

Spectrum Parameter	Setting
Attenuation	Auto
Start Frequency	1000 MHz
Stop Frequency	12750MHz
RB / VB (emission in restricted band)	1 MHz / 1 MHz for Peak, 1 MHz / 10Hz for Average

3.2.2 TEST PROCEDURE

- a. The measuring distance of at 3 m shall be used for measurements at frequency up to 25GHz. For frequencies above 1GHz, any suitable measuring distance may be used.
- b. The EUT was placed on the top of a rotating table 0.8 meters above the ground at a 3 meter semi-chamber test. The table was rotated 360 degrees to determine the position of the highest radiation.
- c. The height of the equipment or of the substitution antenna shall be 0.8m; above 1GHz, the height was 1.5m, the height of the test antenna shall vary between 1 m to 4 m. Both horizontal and vertical polarizations of the antenna are set to make the measurement.
- d. The initial step in collecting conducted emission data is a spectrum analyzer peak detector mode pre-scanning the measurement frequency range. Significant peaks are then marked and then Quasi Peak detector mode re-measured.
- e. If the Peak Mode measured value compliance with and lower than Quasi Peak Mode Limit, the EUT shall be deemed to meet QP Limits and then no additional QP Mode measurement performed.
- f. For the actual test configuration, please refer to the related Item –EUT Test Photos.
- g. For the radiated emission test above 1GHz:
Place the measurement antenna away from each area of the EUT determined to be a source of emissions at the specified measurement distance, while keeping the measurement antenna aimed at the source of emissions at each frequency of significant emissions, with polarization oriented for maximum response.
The measurement antenna may have to be higher or lower than the EUT, depending on the radiation pattern of the emission and staying aimed at the emission source for receiving the maximum signal. The final measurement antenna elevation shall be that which maximizes the emissions. The measurement antenna elevation for maximum emissions shall be restricted to a range of heights of from 1 m to 4 m above the ground or reference ground plane.

Note:

Both horizontal and vertical antenna polarities were tested and performed pretest to three orthogonal axis. The worst case emissions were reported

3.2.3 DEVIATION FROM TEST STANDARD

No deviation

3.2.4 TEST SETUP

(A) Radiated Emission Test-Up Frequency Below 30MHz

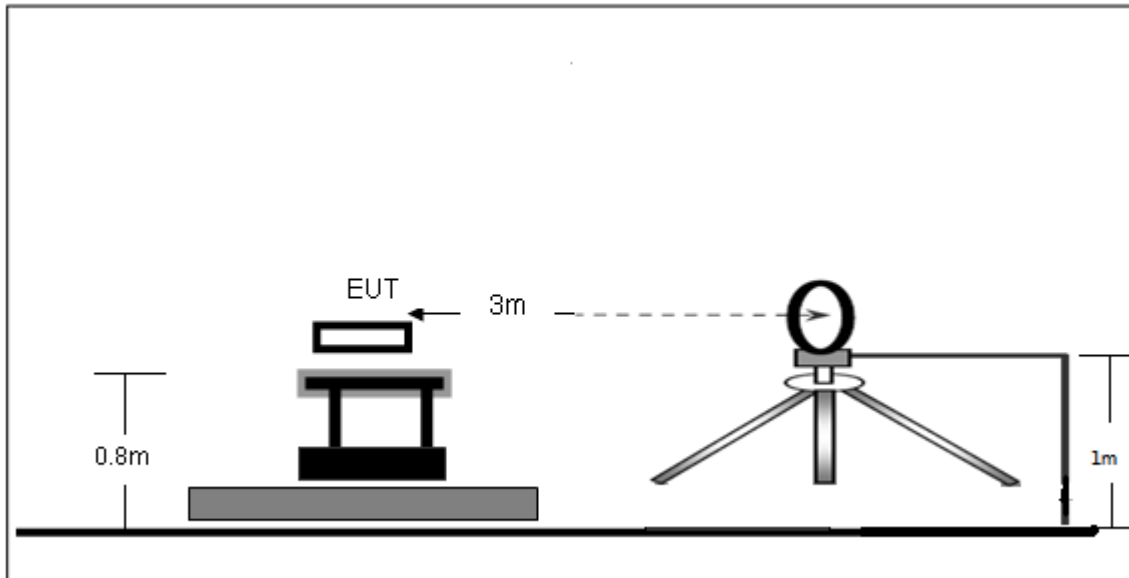

(B) Radiated Emission Test-Up Frequency 30MHz~1GHz

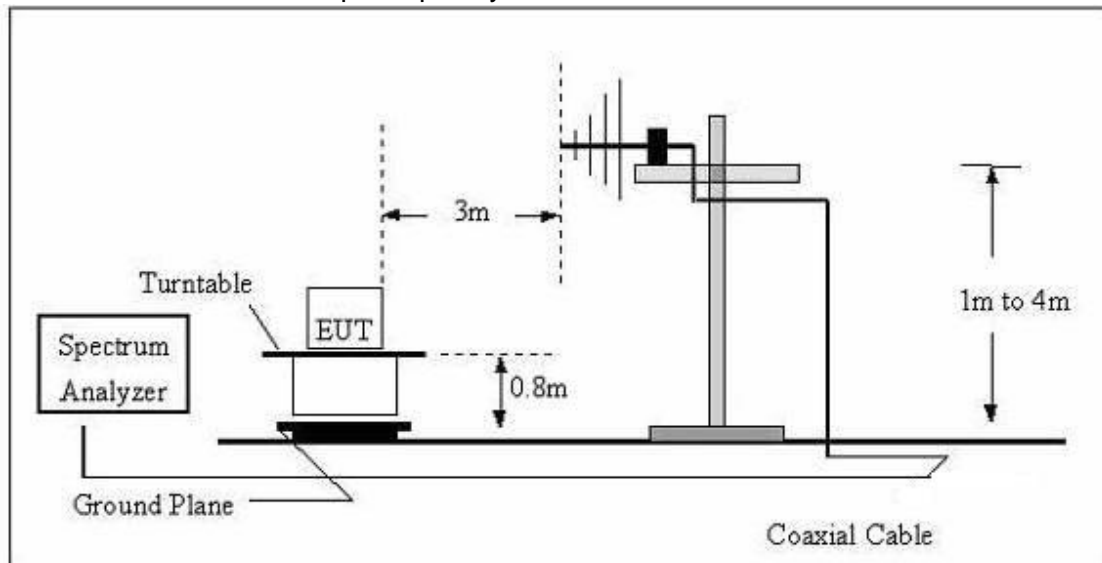

(C) Radiated Emission Test-Up Frequency Above 1GHz

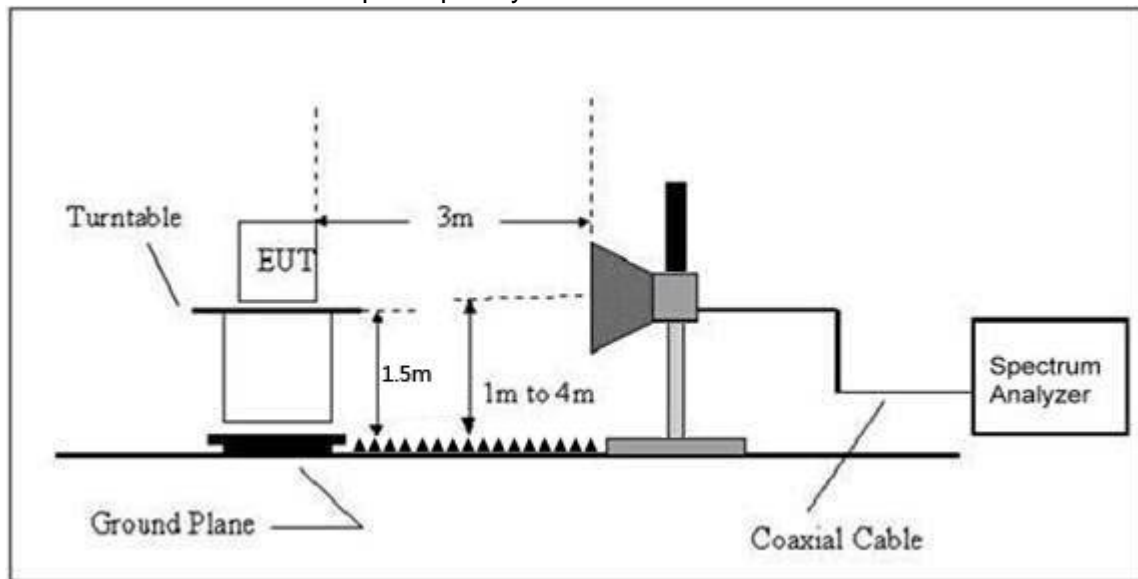

3.2.5 EUT OPERATING CONDITIONS

The EUT tested system was configured as the statements of 2.4 Unless otherwise a special operating condition is specified in the follows during the testing.

3.2.6 TEST RESULTS (BETWEEN 9KHZ – 30 MHZ)

Temperature:	26℃	Relative Humidity:	54%
Pressure:	101 kPa	Test Voltage :	DC 3V
Test Mode :	Mode 1	Polarization :	--

Freq.	Reading	Limit	Margin	State
(MHz)	(dBuV/m)	(dBuV/m)	(dB)	P/F
--	--	--	--	PASS
--	--	--	--	PASS

NOTE:

The amplitude of spurious emissions which are attenuated by more than 20dB below the permissible value has no need to be reported.

Distance extrapolation factor = $40 \log(\text{specific distance}/\text{test distance})$ (dB);

Limit line = specific limits(dBuv) + distance extrapolation factor.

3.2.7 TEST RESULTS (BETWEEN 30MHZ – 1GHZ)

Temperature :	26°C	Relative Humidity :	54%
Pressure :	101 kPa	Polarization :	Horizontal
Test Voltage :	DC 3V		
Test Mode :	Mode 1		

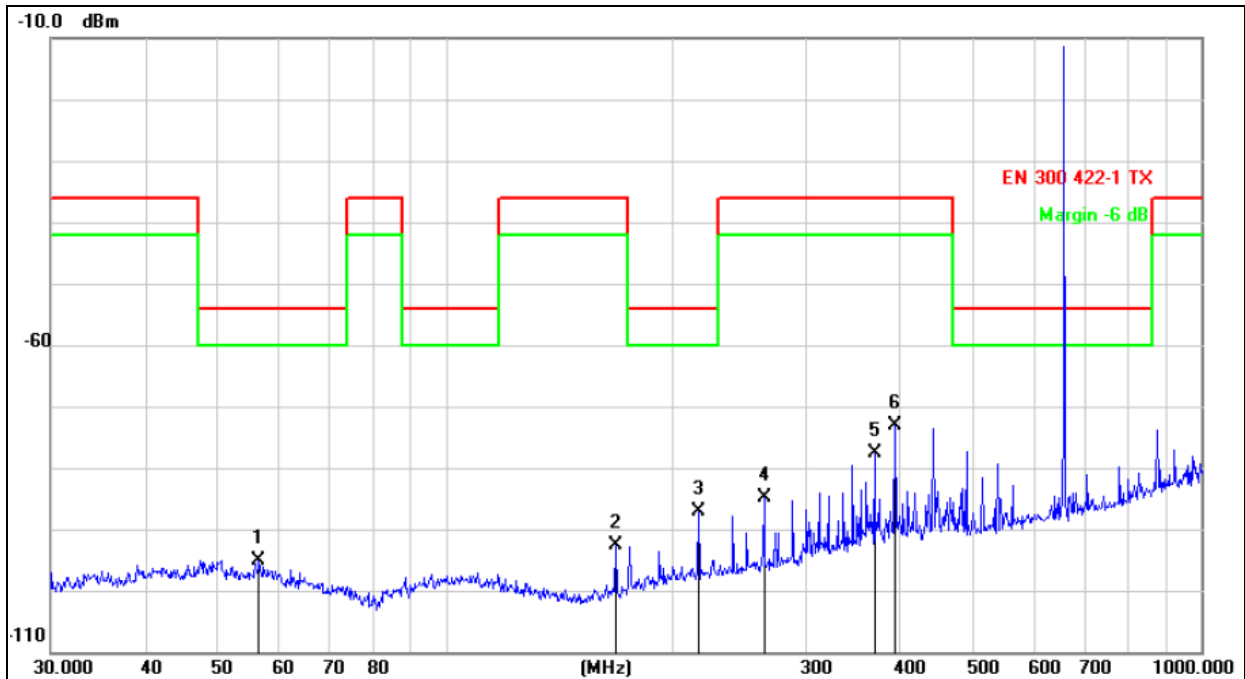

Remark:
 Factor = Antenna Factor + Cable Loss – Pre-amplifier.

No.	Mk.	Freq. MHz	Reading Level dBm	Correct Factor dB	Measure- ment dBm	Limit dB	Over dB	Detector
1		56.5929	-79.62	-15.55	-95.17	-54.00	-41.17	QP
2		167.8243	-74.34	-18.36	-92.70	-36.00	-56.70	QP
3	*	216.0240	-71.13	-15.93	-87.06	-54.00	-33.06	QP
4		263.8190	-70.13	-14.72	-84.85	-36.00	-48.85	QP
5		369.4047	-65.90	-11.79	-77.69	-36.00	-41.69	QP
6		393.4723	-61.79	-11.24	-73.03	-36.00	-37.03	QP



Temperature :	26°C	Relative Humidity :	54%
Pressure :	101kPa	Polarization :	Vertical
Test Voltage :	DC 3V		
Test Mode :	Mode 1		

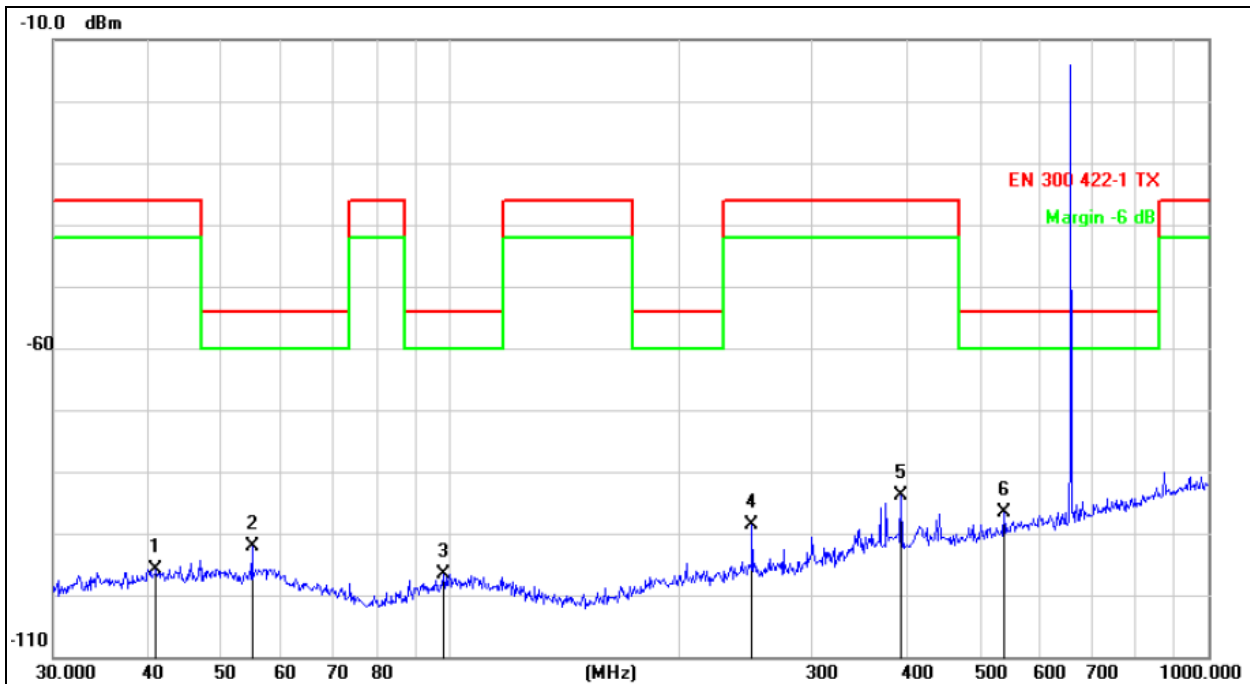

Remark:
Factor = Antenna Factor + Cable Loss – Pre-amplifier.

No.	Mk.	Freq. MHz	Reading Level dBm	Correct Factor dB	Measure- ment dBm	Limit dB	Over dB	Detector
1		40.9881	-80.40	-15.35	-95.75	-36.00	-59.75	QP
2		54.8348	-76.82	-15.36	-92.18	-54.00	-38.18	QP
3		98.1419	-79.98	-16.62	-96.60	-54.00	-42.60	QP
4		250.3011	-73.59	-15.14	-88.73	-36.00	-52.73	QP
5		393.4723	-72.62	-11.24	-83.86	-36.00	-47.86	QP
6	*	537.5891	-78.64	-7.99	-86.63	-54.00	-32.63	QP

Remark:
Test all the modes and only worst case was reported.



3.2.8 TEST RESULTS (1GHz~12.75GHz)

Frequency (MHz)	Receiver Reading (dBm)	Turn table Angle Degree	RX Antenna		Correct	Absolute Level (dBm)	Result	
			Height (m)	Polar (H/V)	Factor (dBm)		Limit (dBm)	Margin (dB)
657.2MHz								
1314.40	-53.76	153	1.8	H	-9.43	-63.19	-30	-33.19
1314.40	-54.63	139	1.4	V	-9.43	-64.06	-30	-34.06
1971.60	-51.83	234	1.6	H	-6.43	-58.26	-30	-28.26
1971.60	-52.35	175	1.5	V	-6.43	-58.78	-30	-28.78
2628.80	-48.99	200	1.4	H	-6.94	-55.93	-30	-25.93
2628.80	-47.96	63	1.9	V	-6.96	-54.92	-30	-24.92

Remark:

Absolute Level = Receiver Reading + Factor

Factor = Antenna Factor + Cable Loss – Pre-amplifier.

4. RF OUTPUT POWER

4.1 TEST REQUIREMENT:

FCC Part15 (15.236) , Subpart C				
Section	Test Item	Limit	Frequency Range (MHz)	Result
15.236	EIRP	20mW	657-663	PASS

4.1.1 TEST PROCEDURE

1. The maximum peak output power was measured with a Spectrum Analyzer connected to the antenna terminal while EUT was operating in unmodulated situation.
2. Power was supplied to the battery input connector a power supply. The power supply was set for +3.0VDC. The Spectrum Analyzer was connected at antenna terminal to measure RF power of the carrier.
3. A Multimeter was connected in series with final RF Stage to measure the current; A Multimeter was used to measure final RF Stage supply voltage. Then the voltage v.s. current of the final RF Stage can be showed.

4.1.2 DEVIATION FROM STANDARD

No deviation.

4.1.3 TEST SETUP



4.1.4 EUT OPERATION CONDITIONS

The EUT tested system was configured as the statements of 2.3 Unless otherwise a special operating condition is specified in the follows during the testing.

4.1.5 TEST RESULTS

Channel	Frequency (MHz)	EIRP(dBm)	EIRP(mW)	Limit (dBm)
01	657.2	6.96	4.97	13

5. BANDWIDTH TEST & EMISSION MASK

5.1 APPLIED PROCEDURES / LIMIT

According to FCC 15.236(f), The operating frequency within a permissible band of operation as defined in paragraph (c) must comply with the following requirements.

- (1) The frequency selection shall be offset from the upper or lower band limits by 25 kHz or an integral multiple thereof.
- (2) One or more adjacent 25 kHz segments within the assignable frequencies may be combined to form a channel whose maximum bandwidth shall not exceed 200 kHz. The operating bandwidth shall not exceed 200 kHz.

Emissions within the band from one megahertz below to one megahertz above the carrier frequency shall comply with the emission mask in Section 8.3 of ETSI EN 300 422-1 V1.4.2 (2011-08) (incorporated by reference, see §15.38). Emissions outside this band shall comply with the limit specified at the edges of the ETSI mask

5.1.1 TEST PROCEDURE

According to TIA-603 for additional Test Set-Up procedures, the occupied bandwidth of emission was measured with a Spectrum Analyzer connected to the antenna terminal while EUT was operating in 2.5kHz tone at an input level 16 dB greater than that necessary to produce 50 percent modulation. Then mark the 99% Occupied Bandwidth and record it.

Emission Mask test procedure:

Necessary Bandwidth (BN) for Analogue Systems

Method of Measurement

The arrangement of test equipment as shown in figure B.1 shall be used. Note that the noise meter conforms to (quasi peak) without weighting filter (flat).

With the Low Frequency (LF) audio signal generator set to 500 Hz, the audio input level to the EUT shall be adjusted to 8 dB below the limiting threshold (-8 dB (lim)) as declared by the manufacturer. The corresponding audio output level from the demodulator shall be measured and recorded.

The input impedance of the noise meter shall be sufficiently high to avoid more than 0,1 dB change in input level when the meter is switched between input and output. The audio input level shall be increased by 20 dB, i.e. to +12 dB (lim), and the corresponding change in output level shall be measured.

It shall be checked that the audio output level has increased by ≤ 10 dB.

If this condition is not met, the initial audio input level shall be increased from -8 dB (lim) in 1 dB steps until the above condition is fulfilled, and the input level recorded in the test report. This level replaces the value derived from the manufacturer's declaration and is defined as -8 dB (lim).

If the transmitter incorporates more than one audio input, e.g. stereo systems, the second and subsequent channels shall be simultaneously driven from the same noise source, attenuated to a level of -6 dB (lim).

The transmitter RF output spectrum shall be measured, using a spectrum analyser with the following settings:



centre frequency:	fc: Transmitter (Tx) nominal frequency;
dispersion (Span):	fc - 1 MHz to fc + 1 MHz;
Resolution BandWidth (RBW):	1 kHz;
Video BandWidth (VBW):	1 kHz;
detector:	Peak hold.

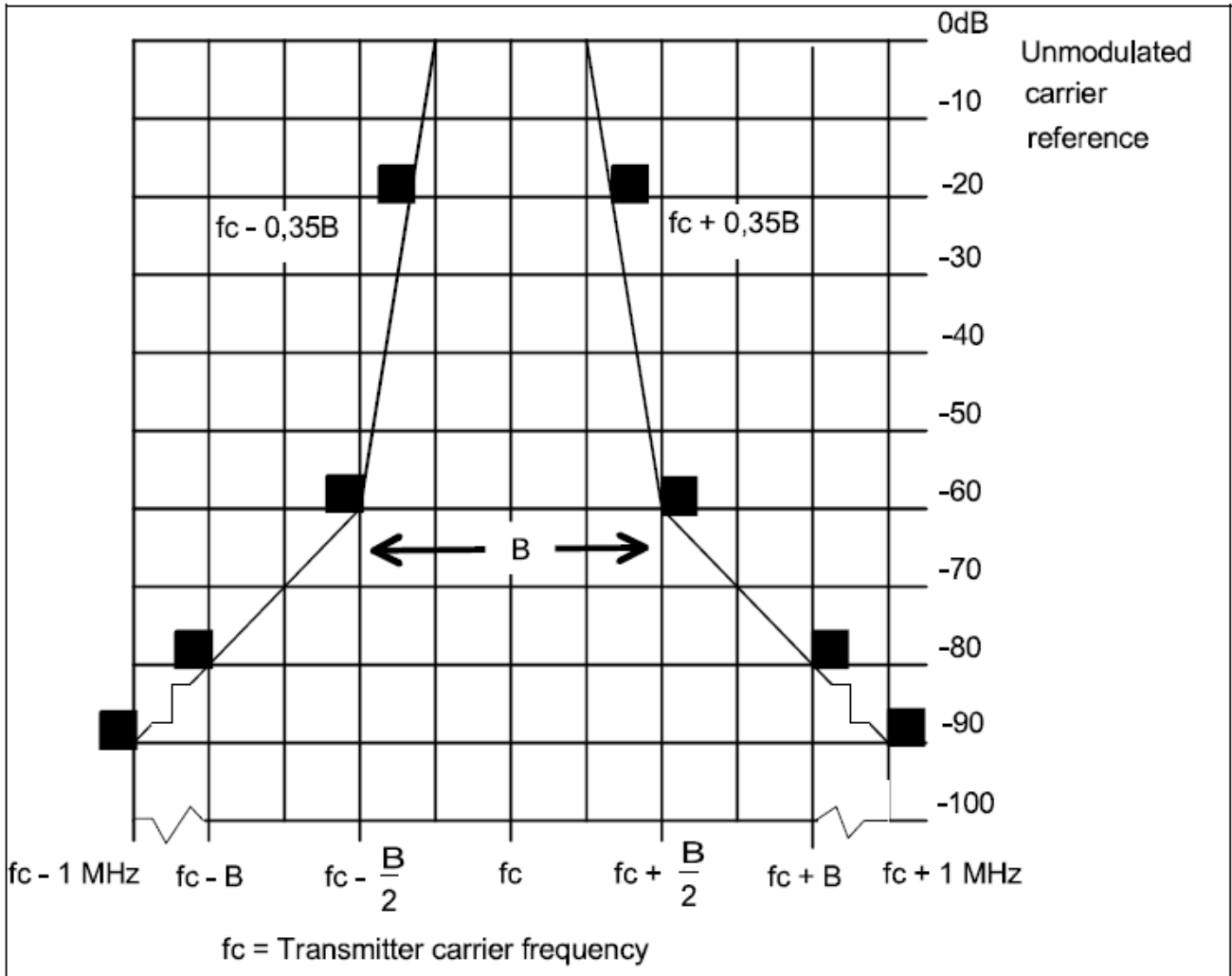



5.1.2 DEVIATION FROM STANDARD

No deviation.

5.1.3 TEST SETUP



5.1.4 EUT OPERATION CONDITIONS

The EUT tested system was configured as the statements of 2.4 Unless otherwise a special operating condition is specified in the follows during the testing.

5.1.5 TEST RESULTS

Temperature :	26°C	Relative Humidity :	54%
Test Mode :	FM	Test Voltage :	DC 3V

Frequency (MHz)	-20dB bandwidth (KHz)	99% Bandwidth (kHz)	Limit (kHz)	Result
657.2	82.08	61.850	200	Pass

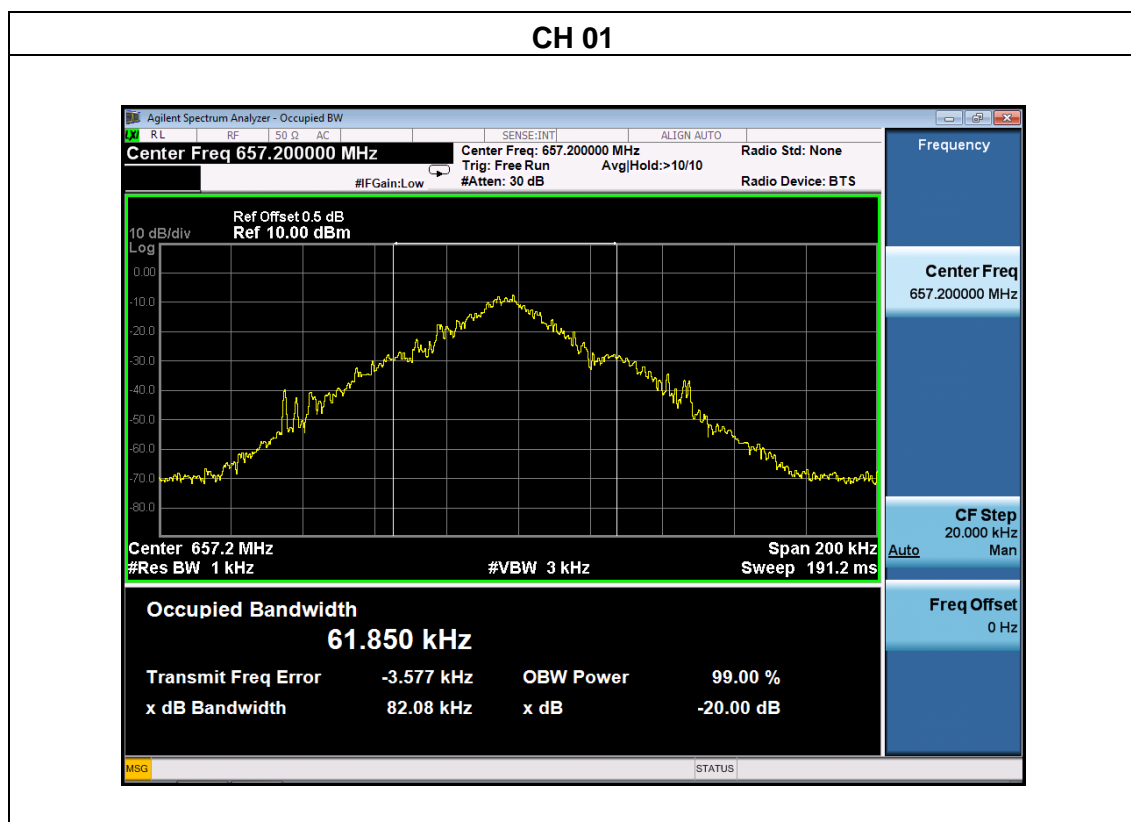

Emission Mask (657.20MHz)

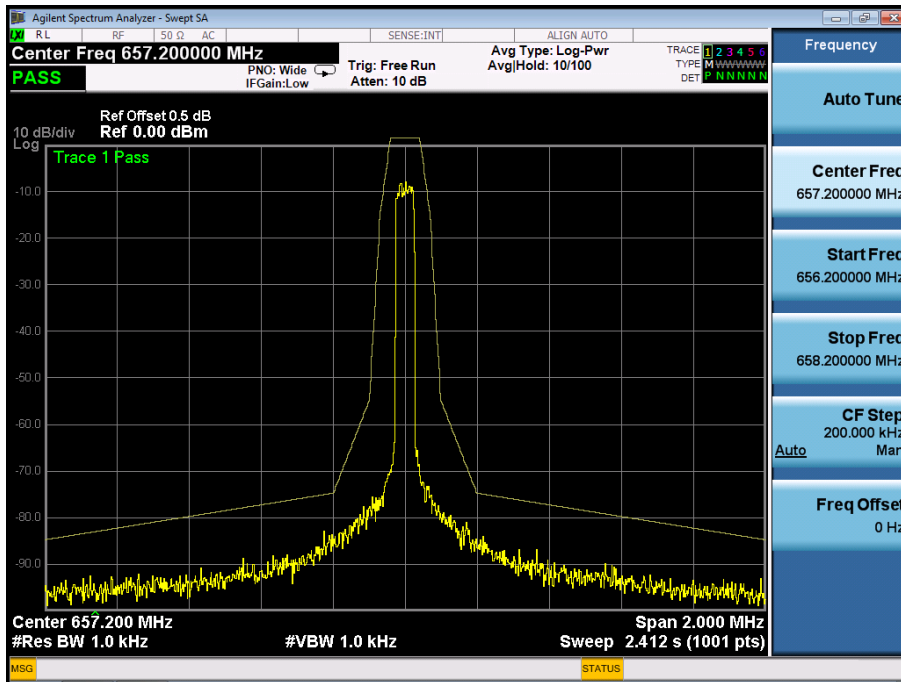
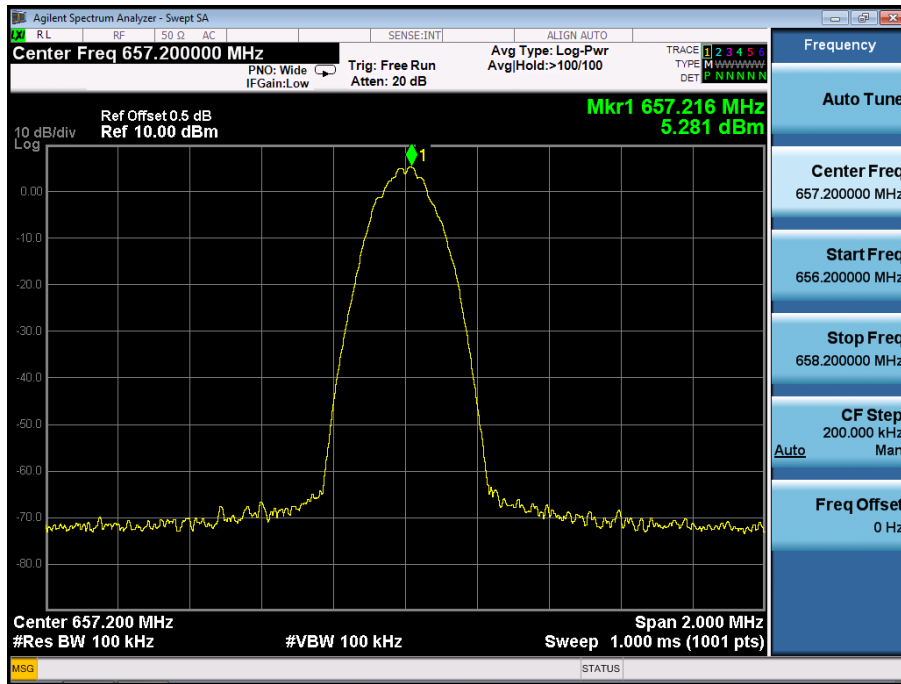

6. FREQUENCY STABILITY

6.1 APPLICABLE STANDARD

According to FCC 15.236(f)(3), The frequency tolerance of the carrier signal shall be maintained within $\pm 0.005\%$ of the operating frequency over a temperature variation of -20 degrees to $+50$ degrees C at normal supply voltage, and for a variation in the primary supply voltage from 85% to 115% of the rated supply voltage at a temperature of 20 degrees C. Battery operated equipment shall be tested using a new battery.

6.2 TEST PROCEDURE

- 1, Setup the configuration of the ambient temperature form -20°C to 50°C with sufficient time. And measure the different power of the EUT with an artificial power from highest to end point voltage.
- 2, Set frequency counter center frequency to the right frequency needs to be measured.

6.3 DEVIATION FROM STANDARD

No deviation.

6.4 TEST SETUP



6.5 EUT OPERATION CONDITIONS

The EUT tested system was configured as the statements of 2.4 Unless otherwise a special operating condition is specified in the follows during the testing.

6.6 TEST RESULTS



Test conditions		Frequency Error
		657.20 MHz
T _{min} (20°C)	V _{min} (2.55V)	657.1985
	V _{max} (3.45V)	657.1971
T(-20°C)	V _{nom} (3.0V)	657.1955
T(-10°C)	V _{nom} (3.0V)	657.1963
T(0°C)	V _{nom} (3.0V)	657.1927
T(10°C)	V _{nom} (3.0V)	657.1935
T _{nom} (20°C)	V _{nom} (3.0V)	657.1905
T(30°C)	V _{nom} (3.0V)	657.1963
T(40°C)	V _{nom} (3.0V)	657.1992
T(50°C)	V _{nom} (3.0V)	657.1955
T _{max} (20°C)	V _{min} (2.55V)	657.1951
	V _{max} (3.45V)	657.1981
Max. frequency error (ppm)		-13.73
Limit (ppm)		±50ppm
End Point		DC 3.0V

7. ANTENNA REQUIREMENT

7.1 STANDARD REQUIREMENT

15.203 requirement: For intentional device, according to 15.203: an intentional radiator shall be designed to ensure that no antenna other than that furnished by the responsible party shall be used with the device.

7.2 EUT ANTENNA

The EUT antenna is Internal antenna, fulfill the requirement of this section.

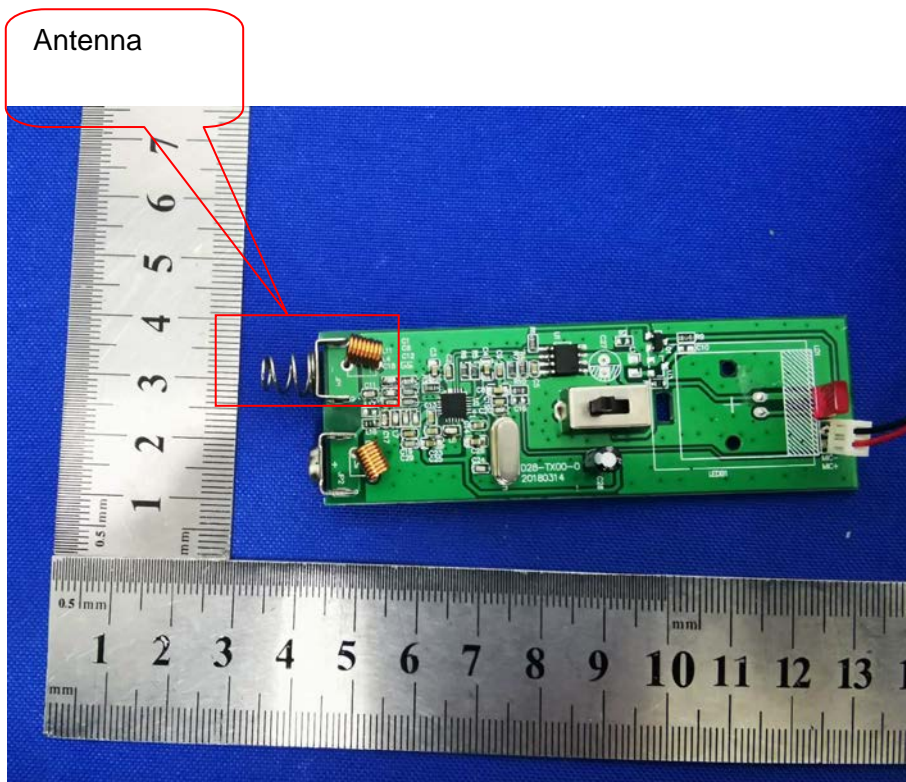

8. EUT TEST PHOTO

Radiated Measurement Photos

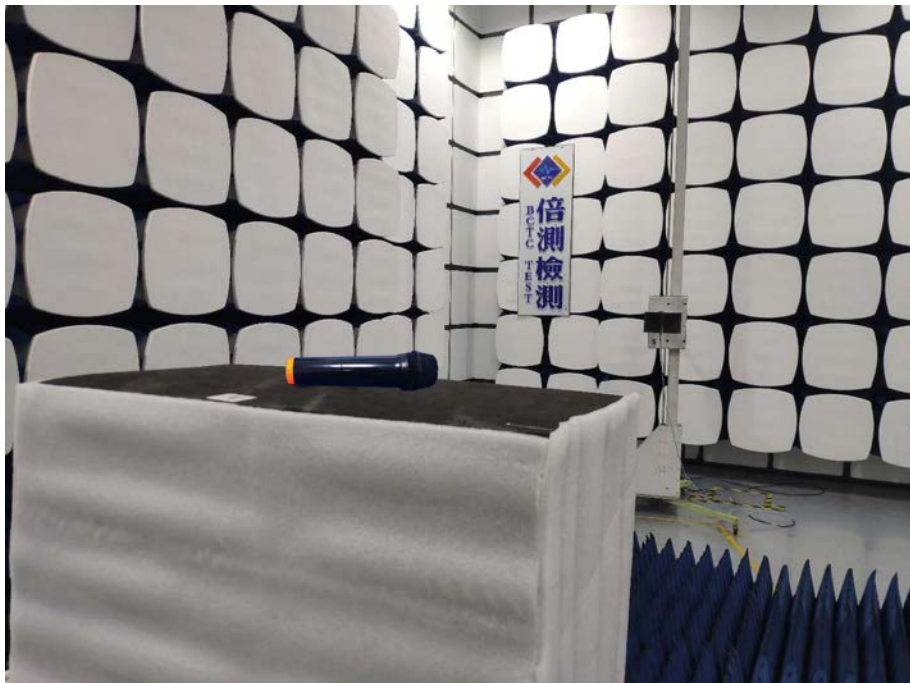

9. EUT PHOTO



***** END OF REPORT *****