

MODEL : JWM45

CUSTOMER : ASA

DATE : 28/09/2018

DESCRIPTION : LABEL SPECIFICATION

REVISION : 0

PAGE : 1 OF : 7

1. Unit label



- 5 Serial No
- 1 N=New, R=Remanufactured
- 3 Factory Code
- 2 digit Production Year
- 2 digit Production Month
- 1 Customer Revision Control:  
ES1=1, ES2=2, PP=A(SRA Approve)  
MP=A

Blank Label : 602500940G (40x50mm)  
 Format : Code 128  
 Position : Unit(1PC)  
 Remark : 14 digits Barcode

2. GB label

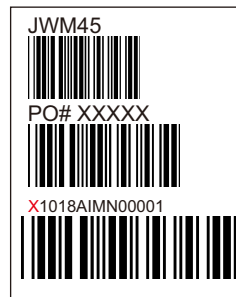

Blank Label : 602500940G (40x50mm)  
 Format : Code 128  
 Position : GB(1PC)  
 Remark : 14 digits Barcode



GB LOGO LABEL: (120x75mm)(2PC)  
 P/N:908W00000G



WHITE WARNING LABEL(170 x 20mm)(1PC)  
 FONT SIZE:16PT  
 P/N: 90AF00010G

3. PDF label

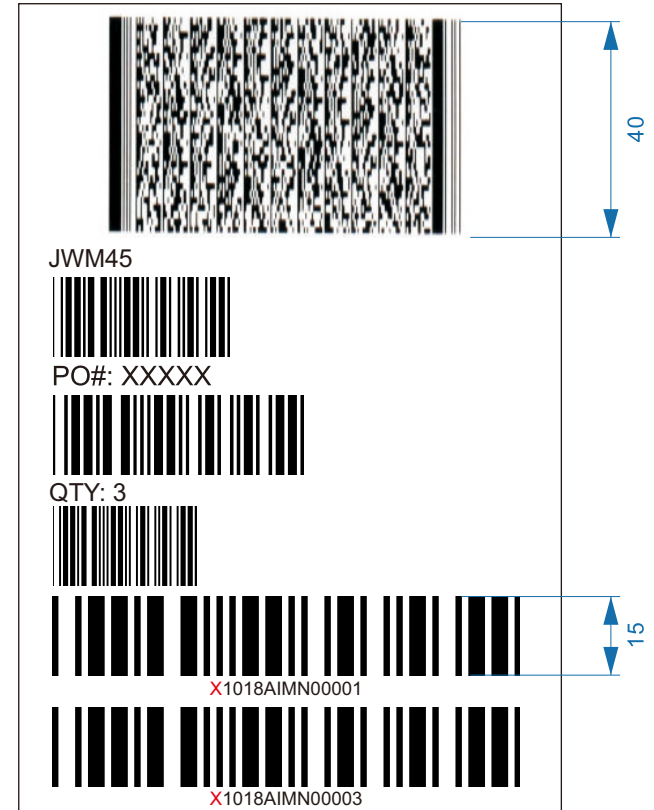

Blank Label : 60-25-00500G (152 x 102mm)  
 Format : Code 128  
 Position : Carton(2PC)

**2D Barcode:** Contained Info of Model No, PO, QTY & First Serial No., last Serial No.  
**Model No:** XXXXX (ASA Model No)  
**PO:** Purchase Order Number.  
**QTY:** Number of units contained in the carton box.  
**Serial No:** Serial No assigned for each unit.

MODEL: JWM45

CUSTOMER: ASA

DATE: 28/09/2018

DESCRIPTION: LABEL LOCATION ON UNIT

REVISION: 0

PAGE: 2 OF: 7

1. MODEL PLATE(80x80mm)

P/N: 508W100A0G

**JENSEN**  
DESIGNED TO MOVE [YOU]™

**MODEL: JWM45**  
JENSEN 2-ZONE WALL STEREO

+12V DC NEGATIVE GROUND  
Power Input: DC 12V, --- 10A  
USB Output: DC 5V, --- 1A(max)  
FCC ID: 2AHU2JWM45

PIN	COLOR	FUNCTION
1.	VIOLET/BLACK	RIGHT(B) SPEAKER -
2.	VIOLET	RIGHT(B) SPEAKER +
3.	GREEN	LEFT(B) SPEAKER +
4.	GREEN/BLACK	LEFT(B) SPEAKER -
5.	N/A	
6.	GRAY	RIGHT(A) SPEAKER +
7.	GRAY/BLACK	RIGHT(A) SPEAKER -
8.	N/A	
9.	WHITE/BLACK	LEFT(A) SPEAKER -
10.	WHITE	LEFT(A) SPEAKER +
11.	N/A	
12.	N/A	
13.	N/A	
14.	BLUE	AMP REMOTE(+12V DC 100MA)
15.	RED	+12V DC SWITCHED
16.	BLACK	GROUND
17.	N/A	
18.	N/A	
19.	N/A	
20.	N/A	

\*REPLACE FUSE WITH DC 32V 10AMP ATO TYPE FUSE  
**IMPORTANT: DO NOT BRIDGE (COMBINE) SPEAKER OUTPUTS**  
FAILURE TO WIRE CORRECTLY MAY CAUSE DAMAGE TO UNIT

THIS DEVICE COMPLIES WITH PART 15 OF THE FCC RULES. OPERATION IS SUBJECT TO THE FOLLOWING TWO CONDITIONS:  
(1) THIS DEVICE MAY NOT CAUSE HARMFUL INTERFERENCE, AND  
(2) THIS DEVICE MUST ACCEPT ANY INTERFERENCE RECEIVED, INCLUDING INTERFERENCE THAT MAY CAUSE UNDESIREED OPERATION.

THIS PRODUCT COMPLIES WITH DHHS RULES 21 CFR SUBCHAPTER J AT DATE OF MANUFACTURE

**asa** ELECTRONICS. [www.asaelectronics.com](http://www.asaelectronics.com)  
MADE IN CHINA

2. Unit label

P/N: 602500940G

JWM45

X1018AIMN0001

3. WARNING LABEL

P/N: 908W00010G

27.5MM

79.5MM

4. CLASS 1 LASER PRODUCT LABEL

P/N: 90AK00000G

27MM

55MM

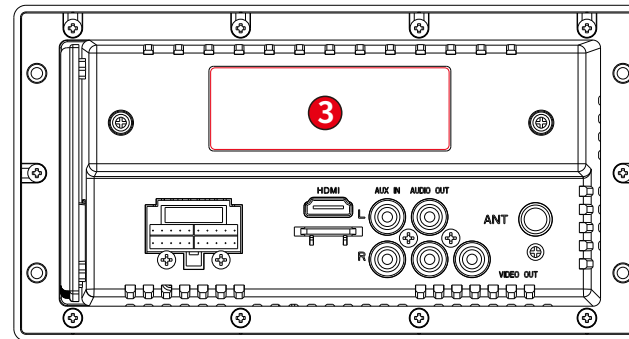
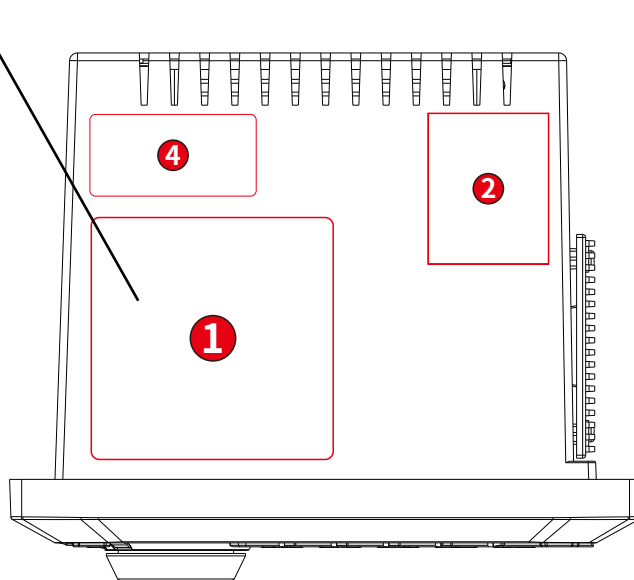

**PACKING METHOD**

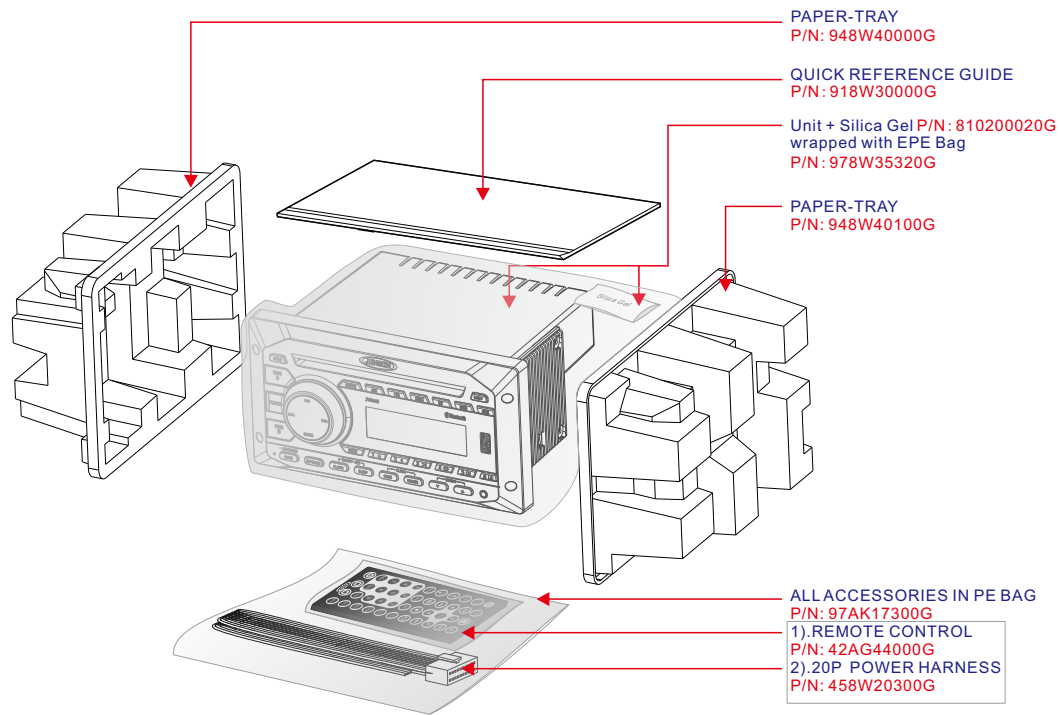

QUICK REFERENCE GUIDE

ACCESSORIES PE BAG

**PACKING METHOD (CARTON)**

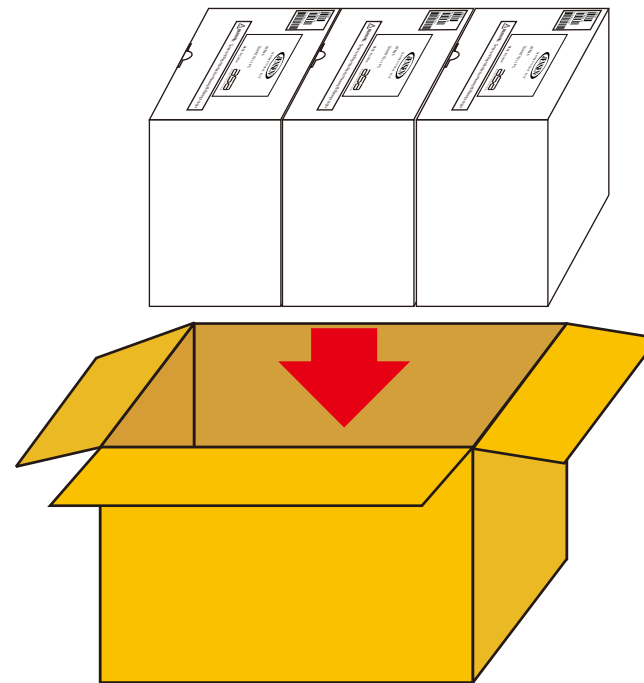

3 set Gift Box  
pack in  
each carton

Use the red tape with below letter to seal the master carton as shown.



Figure 1



Figure 2

MODEL: JWM45

CUSTOMER: ASA

DATE: 28/09/2018

DESCRIPTION: LABEL LOCATION IN GIFT BOX & CARTON

REVISION: 0

PAGE: 4 OF: 7

### 1. Gift Box Label

**WARNING:** Cancer and Reproductive Harm-[www.p65Warnings.ca.gov](http://www.p65Warnings.ca.gov)

Font Size:16pt

**JENSEN**  
 DESIGNED TO MOVE [YOU]<sup>™</sup>

JWM45  
 QUANTITY=1PC

MADE IN CHINA

**asa**  
 ELECTRONICS.

Font Size:12pt Font Size:14pt

JWM45  
 PO# XXXXX  
 X0718AIMN00001

GB P/N:938W2000G

220mm

155mm

250mm

### 2. PDF Label

JWM45  
 PO# XXXXX  
 QTY: 3  
 X0718AIMN00001

### 3. Carton Label P/N: 602500350G

XXXXX  
 JWM45  
 1-UP

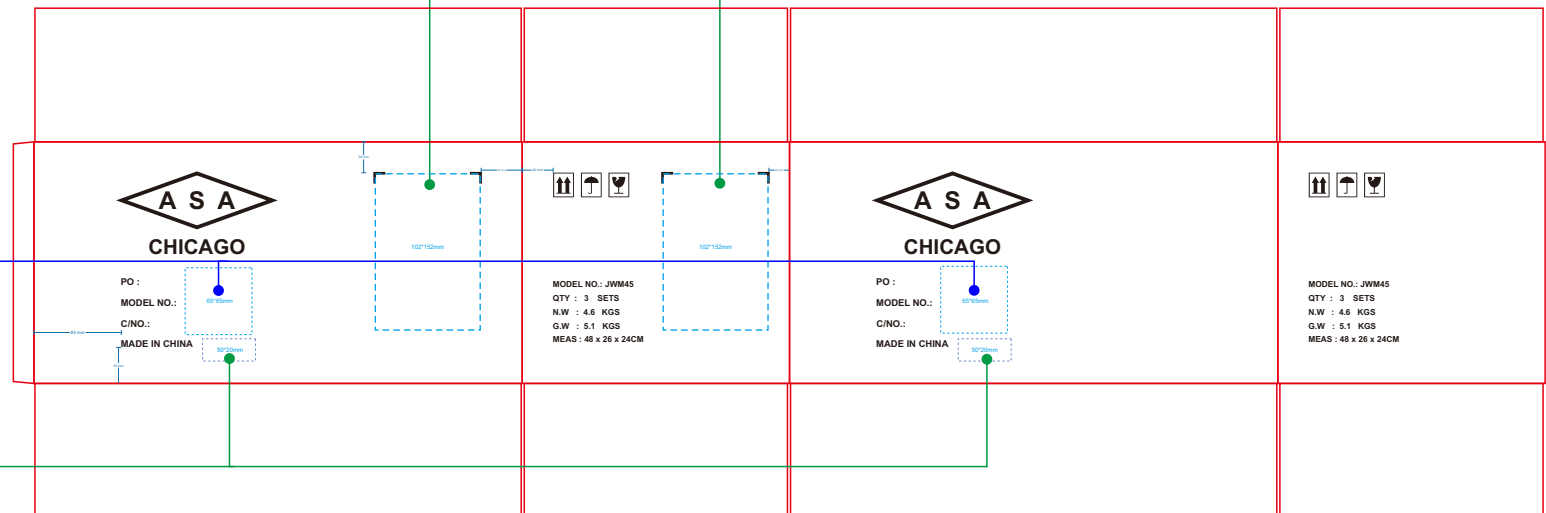

### 4. Index Label P/N: 6025004A0G

(Index#00000)

MODEL: JWM45

CUSTOMER: ASA





DATE: 28/09/2018

DESCRIPTION: CARTON SPECIFICATION

REVISION: 0

PAGE: 5 OF: 7

**CARTON SPECIFICATION** P/N: 948W10000G

 <b>ASA</b> <b>CHICAGO</b> PO : MODEL NO.: C/NO.: MADE IN CHINA	 MODEL NO.: JWM45 QTY : 3 SETS N.W : 4.6 KGS G.W : 5.1 KGS MEAS : 48 x 26 x 24CM	 <b>ASA</b> <b>CHICAGO</b> PO : MODEL NO.: C/NO.: MADE IN CHINA	 MODEL NO.: JWM45 QTY : 3 SETS N.W : 4.6 KGS G.W : 5.1 KGS MEAS : 48 x 26 x 24CM

EXTERNAL DIMENSION: 48(L) x26(W) x 24(H)cm

SPECIFICATION :-

1. MATERIAL : A=A
2. PRINTING : 1 COLOR PROCESS PRINTING - BLACK (FONT : ARIAL)
3. QUALITY : NO DOUBLE IMAGE PRINTING, INK CONSISTENCY & NO OVERLAPING.
4. REMARK : COMPLETED 2 PCS/CTN
5. OTHERS : (A) = BOX CERTIFICATED  
PO: TO BE PRINTING ON CARTON (REFER TO MO)  
C/NO: USING HANDWRITING (1,2,3....)
6. TOLERANCE : ±3MM

MODEL: JWM45

CUSTOMER: ASA

DATE: 28/09/2018

DESCRIPTION: COSMETIC SPECIFICATION

REVISION: 0

PAGE: 6 OF: 7

### 1. UNIT SIX VIEWS

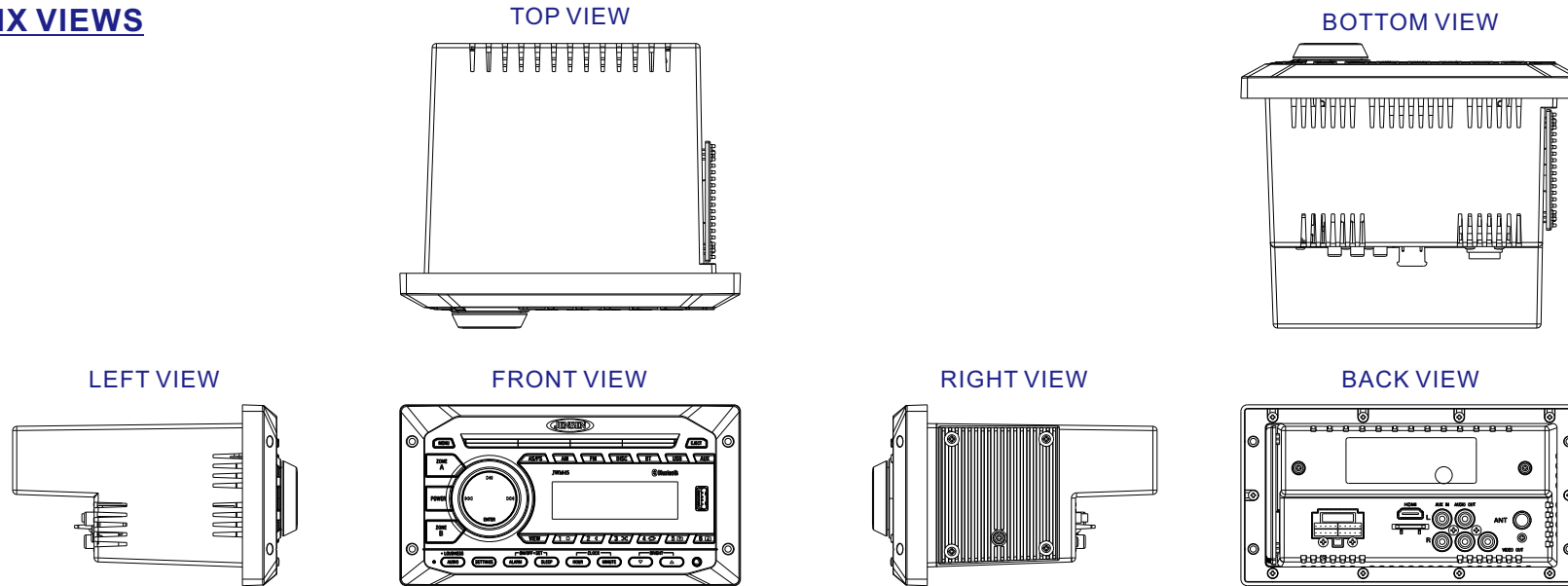

### 2. 20P POWER HARNESS

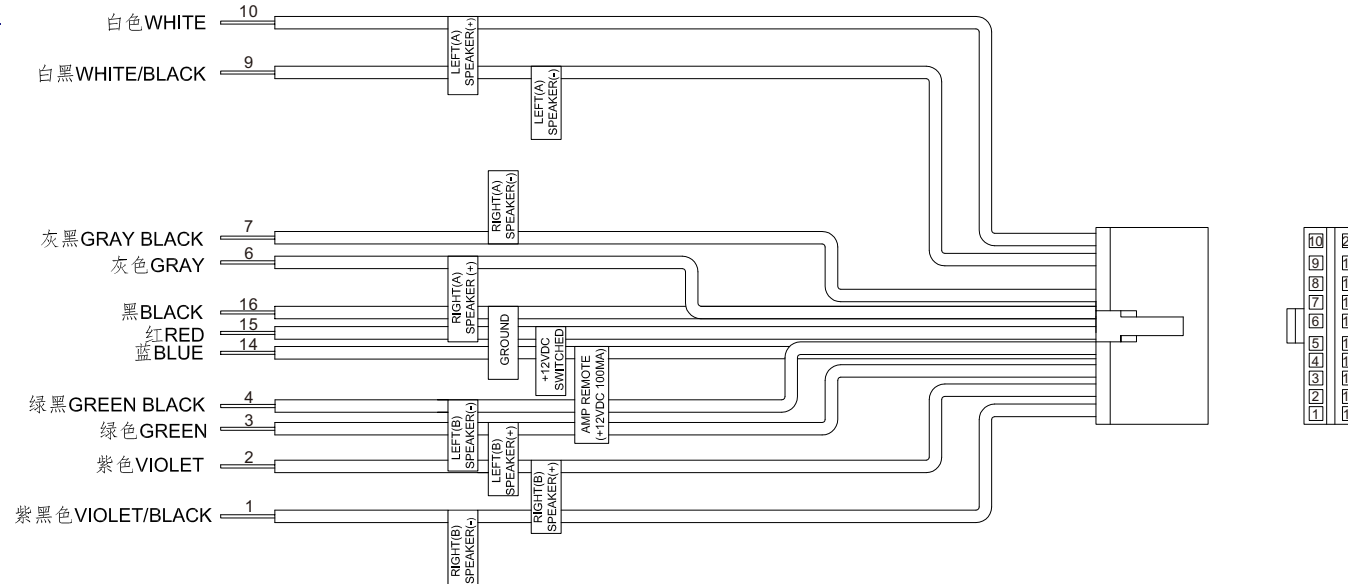

MODEL: JWM45

CUSTOMER: ASA

DATE: 28/09/2018

DESCRIPTION: LOADING CAPACITY

REVISION: 0

PAGE: 7 OF: 7

### Customer Loading Capacity

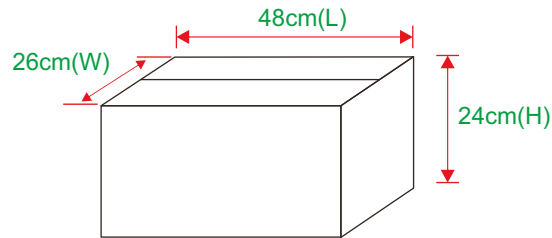

Carton Quantity = 10pcs  
 Carton Dimension (external) = 48(L) x 26(W) x 24(H)cm  
 N.W = 9.9 LBS/ 4.5 KGS  
 G.W = 11.2 LBS/ 5.1 KGS

Example:

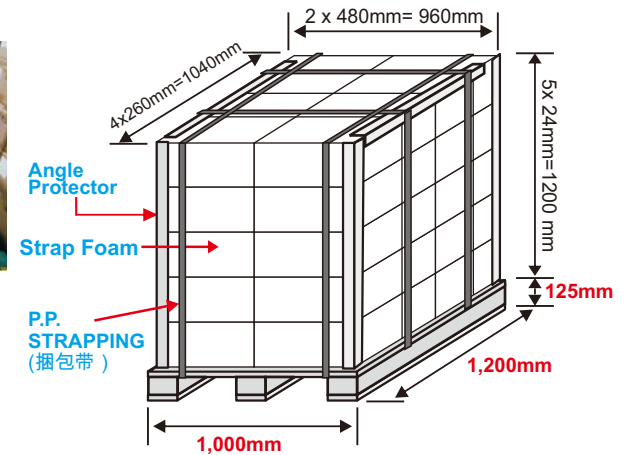

Pallet size: 1200 x 1000 x 125mm  
 (48" x 40")

Quantity per layer: 8 cartons  
 Stacking layer: 5 layers

#### 20' Container Top View

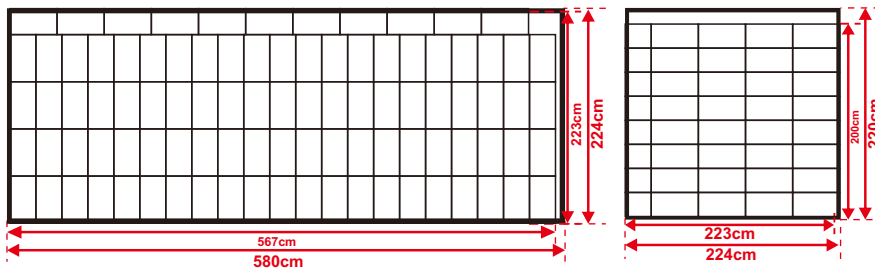

Stacking Layer: 8 Layers

**20' Container (without pallets)**  
**Loading Quantity:**  
 = 95 x H8  
 = 760 cartons x 3 sets  
 = 2,280 sets

#### 40' Container Top View

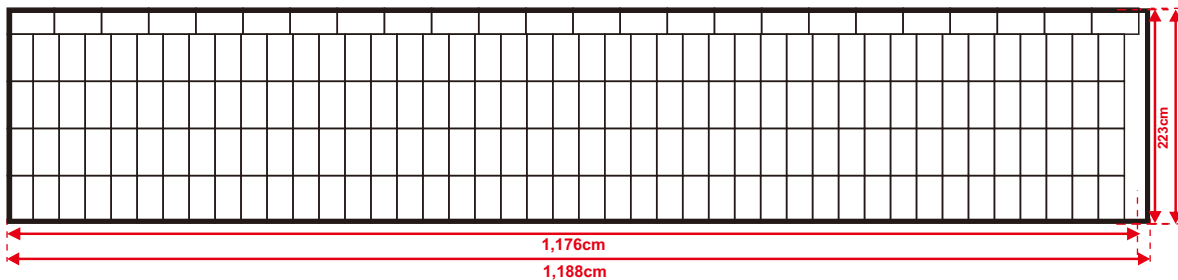

#### Front View

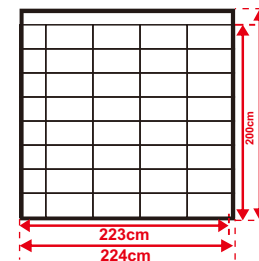

**40' Container (without pallets)**  
**Loading Quantity:**  
 = 196 x H8  
 = 1,568 cartons x 3 sets  
 = 4,704 sets