



FCC RF Test Report

APPLICANT : Altocumulous LLC
EQUIPMENT : Digital Media Receiver
MODEL NAME : RS03QR
FCC ID : 2AHSE-2045
STANDARD : FCC Part 15 Subpart C §15.247
CLASSIFICATION : (DTS) Digital Transmission System

This is a variant report which is only valid together with the original test report. The testing was completed on Dec. 02, 2016. We, SPORTON INTERNATIONAL INC., would like to declare that the tested sample has been evaluated in accordance with the test procedures and has been in compliance with the applicable technical standards.

The test results in this report apply exclusively to the tested model / sample. Without written approval of SPORTON INTERNATIONAL INC., the test report shall not be reproduced except in full.

Reviewed by: Joseph Lin / Supervisor

Approved by: Jones Tsai / Manager



SPORTON INTERNATIONAL INC.

No. 52, Hwa Ya 1st Rd., Hwa Ya Technology Park, Kwei-Shan District, Tao Yuan City, Taiwan, R.O.C.



TABLE OF CONTENTS

REVISION HISTORY..... 3

SUMMARY OF TEST RESULT 4

1 GENERAL DESCRIPTION 5

 1.1 Applicant 5

 1.2 Product Feature of Equipment Under Test..... 5

 1.3 Product Specification of Equipment Under Test..... 5

 1.4 Modification of EUT 5

 1.5 Testing Location 6

 1.6 Applicable Standards..... 6

2 TEST CONFIGURATION OF EQUIPMENT UNDER TEST 7

 2.1 Carrier Frequency and Channel 7

 2.2 Test Mode..... 7

 2.3 Connection Diagram of Test System..... 8

 2.4 Support Unit used in test configuration and system 9

 2.5 EUT Operation Test Setup 9

3 TEST RESULT 10

 3.1 Peak Output Power Measurement 10

 3.2 Radiated Band Edges and Spurious Emission Measurement 11

 3.3 Antenna Requirements 15

4 LIST OF MEASURING EQUIPMENT 16

5 UNCERTAINTY OF EVALUATION 17

APPENDIX A. CONDUCTED TEST RESULTS

APPENDIX B. RADIATED SPURIOUS EMISSION

APPENDIX C. RADIATED SPURIOUS EMISSION PLOTS

APPENDIX D. DUTY CYCLE PLOTS



REVISION HISTORY

REPORT NO.	VERSION	DESCRIPTION	ISSUED DATE
FR631725-02C	Rev. 01	Initial issue of report	Oct. 14, 2016
FR631725-02C	Rev. 02	Add rear view photo for radiation emission in setup photo and change conducted power in report appendix a.	Dec. 02, 2016



SUMMARY OF TEST RESULT

Report Section	FCC Rule	Description	Limit	Result
3.1	15.247(b)	Power Output Measurement	$\leq 30\text{dBm}$	Pass
3.2	15.247(d)	Radiated Band Edges and Radiated Spurious Emission	15.209(a) & 15.247(d)	Pass
3.3	15.203 & 15.247(b)	Antenna Requirement	N/A	Pass



1 General Description

1.1 Applicant

Altocumulous LLC

300 E. Business Way, Suite 200, Summit Woods Corporate Center Cincinnati, Ohio 45241

1.2 Product Feature of Equipment Under Test

Product Feature	
Equipment	Digital Media Receiver
Model Name	RS03QR
FCC ID	2AHSE-2045
EUT supports Radios application	WLAN 11b/g/n HT20 WLAN 11a/n HT20/HT40 Bluetooth v4.1 EDR/LE

Remark: This is a variant report by adding 2nd RF crystal. All the test cases were performed on original report which can be referred to Sporton Report Number FR631725-01E. Based on the original report, only conducted output power and Unwanted Emissions were verified.

1.3 Product Specification of Equipment Under Test

Standards-related Product Specification							
Tx/Rx Channel Frequency Range	2412 MHz ~ 2462 MHz						
Maximum (Peak) Output Power to antenna	<Ant. 1> 802.11b : 22.90 dBm (0.1950 W) 802.11g : 25.00 dBm (0.3162 W) 802.11n HT20 : 24.94 dBm (0.3119 W) <Ant. 2> 802.11b : 24.10 dBm (0.2570 W) 802.11g : 25.21 dBm (0.3319 W) 802.11n HT20 : 25.16 dBm (0.3281 W)						
Antenna Type	<Ant. 1> : Fixed Internal type with gain 1.47 dBi <Ant. 2> : Fixed Internal type with gain 2.36 dBi						
Type of Modulation	802.11b : DSSS (DBPSK / DQPSK / CCK) 802.11g/n : OFDM (BPSK / QPSK / 16QAM / 64QAM)						
Antenna Function for Transmitter	<table border="1"> <thead> <tr> <th></th> <th>Ant. 1</th> <th>Ant. 2</th> </tr> </thead> <tbody> <tr> <td>802.11 b/g/n</td> <td>V</td> <td>V</td> </tr> </tbody> </table>		Ant. 1	Ant. 2	802.11 b/g/n	V	V
	Ant. 1	Ant. 2					
802.11 b/g/n	V	V					

1.4 Modification of EUT

No modifications are made to the EUT during all test items.



1.5 Testing Location

Sporton Lab is accredited to ISO 17025 by Taiwan Accreditation Foundation (TAF code : 1190) and the FCC designation No. TW1022 under the FCC 2.948(e) by Mutual Recognition Agreement (MRA) in FCC Test.

Test Site	SPORTON INTERNATIONAL INC.
Test Site Location	No. 52, Hwa Ya 1 st Rd., Hwa Ya Technology Park, Kwei-Shan District, Tao Yuan City, Taiwan, R.O.C. TEL: +886-3-327-3456 FAX: +886-3-328-4978
Test Site No.	Sporton Site No. TH05-HY

Note: The test site complies with ANSI C63.4 2014 requirement.

Test Site	SPORTON INTERNATIONAL INC.
Test Site Location	No.58, Aly. 75, Ln. 564, Wenhua 3rd Rd. Guishan Dist, Taoyuan City, Taiwan (R.O.C.) TEL: +886-3-327-0868 FAX: +886-3-327-0855
Test Site No.	Sporton Site No. 03CH13-HY

Note: The test site complies with ANSI C63.4 2014 requirement.

1.6 Applicable Standards

According to the specifications of the manufacturer, the EUT must comply with the requirements of the following standards:

- ♦ FCC Part 15 Subpart C §15.247
- ♦ FCC KDB Publication No. 558074 D01 DTS Meas. Guidance v03r05
- ♦ ANSI C63.10-2013

Remark: All test items were verified and recorded according to the standards and without any deviation during the test.



2 Test Configuration of Equipment Under Test

The EUT has been associated with peripherals and configuration operated in a manner tended to maximize its emission characteristics in a typical application. Frequency range investigated: radiated emission (9 kHz to the 10th harmonic of the highest fundamental frequency or to 40 GHz, whichever is lower).

2.1 Carrier Frequency and Channel

Frequency Band	Channel	Freq. (MHz)	Channel	Freq. (MHz)
2400-2483.5 MHz	1	2412	7	2442
	2	2417	8	2447
	3	2422	9	2452
	4	2427	10	2457
	5	2432	11	2462
	6	2437		

2.2 Test Mode

Final test mode of radiated spurious emissions are considering the modulation and worse data rates as below table.

Modulation	Data Rate
802.11b	1 Mbps
802.11g	6 Mbps
802.11n HT20	MCS0

2.3 Connection Diagram of Test System

<Ant. 1>

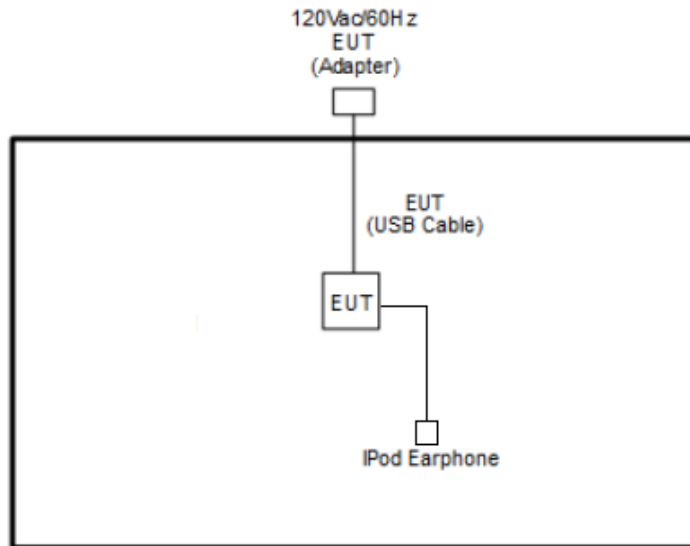

< Ant. 2>

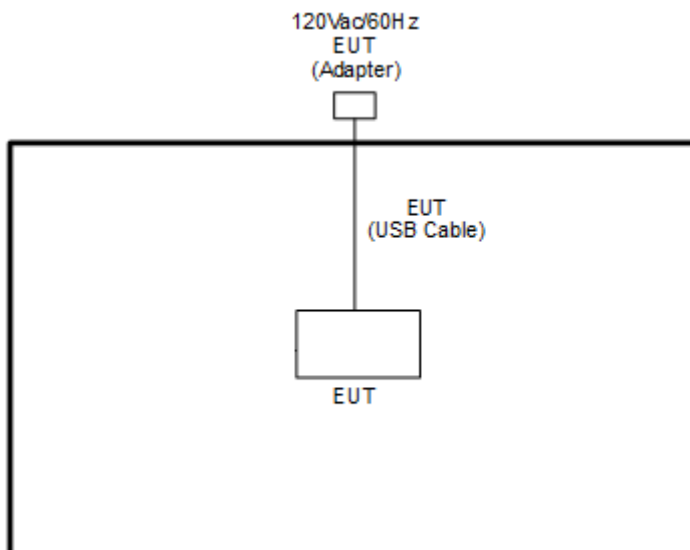



2.4 Support Unit used in test configuration and system

Item	Equipment	Trade Name	Model Name	FCC ID	Data Cable	Power Cord
1.	iPod Earphone	Apple	N/A	Verification	Unshield, 1.0m	N/A

2.5 EUT Operation Test Setup

For WLAN function, programmed RF utility, "Compliance.exe" installed in the notebook make the EUT provide functions like channel selection and power level for continuous transmitting and receiving signals.

3 Test Result

3.1 Peak Output Power Measurement

3.1.1 Limit of Peak Output Power

For systems using digital modulation in the 2400-2483.5MHz, the limit for peak output power is 30dBm. If transmitting antenna with directional gain greater than 6dBi is used, the peak output power from the intentional radiator shall be reduced below the above stated value by the amount in dB that the directional gain of the antenna exceeds 6 dBi. In case of point-to-point operation, the limit has to be reduced by 1dB for every 3dB that the directional gain of the antenna exceeds 6dBi.

3.1.2 Measuring Instruments

The measuring equipment is listed in the section 4 of this test report.

3.1.3 Test Procedures

1. The testing follows the Measurement Procedure of FCC KDB No. 558074 DTS D01 Meas. Guidance v03r05 section 9.1.2 PKPM1 Peak power meter method.
2. The RF output of EUT was connected to the power meter by RF cable and attenuator. The path loss was compensated to the results for each measurement.
3. Set to the maximum power setting and enable the EUT transmit continuously.
4. Measure the conducted output power and record the results in the test report.

3.1.4 Test Setup

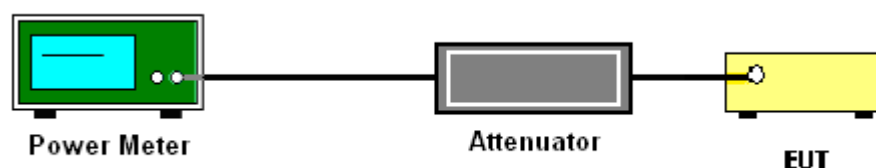

3.1.5 Test Result of Peak Output Power

Please refer to Appendix A.

3.1.6 Test Result of Average output Power (Reporting Only)

Please refer to Appendix A.



3.2 Radiated Band Edges and Spurious Emission Measurement

3.2.1 Limit of Radiated band edge and Spurious Emission Measurement

In any 100 kHz bandwidth outside the intentional radiator frequency band, all harmonics/spurious must be at least 20 dB below the highest emission level within the authorized band. If the output power of this device was measured by spectrum analyzer, the attenuation under this paragraph shall be 30 dB instead of 20 dB. In addition, radiated emissions which fall in the restricted bands must also comply with the FCC section 15.209 limits as below.

Frequency (MHz)	Field Strength (microvolts/meter)	Measurement Distance (meters)
0.009 – 0.490	2400/F(kHz)	300
0.490 – 1.705	24000/F(kHz)	30
1.705 – 30.0	30	30
30 – 88	100	3
88 – 216	150	3
216 - 960	200	3
Above 960	500	3

3.2.2 Measuring Instruments

The measuring equipment is listed in the section 4 of this test report.



3.2.3 Test Procedure

1. The testing follows FCC KDB Publication No. 558074 D01 DTS Meas. Guidance v03r05.
2. The EUT was arranged to its worst case and then tune the antenna tower (from 1 m to 4 m) and turntable (from 0 degree to 360 degrees) to find the maximum reading. A pre-amp and a high pass filter are used for the test in order to get better signal level.
3. The EUT was placed on a turntable with 0.8 meter for frequency below 1GHz and 1.5 meter for frequency above 1GHz respectively above ground.
4. The EUT was set 3 meters from the interference receiving antenna, which was mounted on the top of a variable height antenna tower.
5. Corrected Reading: Antenna Factor + Cable Loss + Read Level - Preamp Factor = Level
6. For measurement below 1GHz, If the emission level of the EUT measured by the peak detector is 3 dB lower than the applicable limit, the peak emission level will be reported. Otherwise, the emission measurement will be repeated using the quasi-peak detector and reported.
7. Use the following spectrum analyzer settings:
 - (1) Span shall wide enough to fully capture the emission being measured;
 - (2) Set RBW=100 kHz for $f < 1$ GHz; VBW \geq RBW; Sweep = auto; Detector function = peak; Trace = max hold;
 - (3) Set RBW = 1 MHz, VBW= 3MHz for $f \geq 1$ GHz for peak measurement.
For average measurement:
 - VBW = 10 Hz, when duty cycle is no less than 98 percent.
 - VBW $\geq 1/T$, when duty cycle is less than 98 percent where T is the minimum transmission duration over which the transmitter is on and is transmitting at its maximum power control level for the tested mode of operation.

3.2.4 Test Setup

For radiated emissions below 30MHz

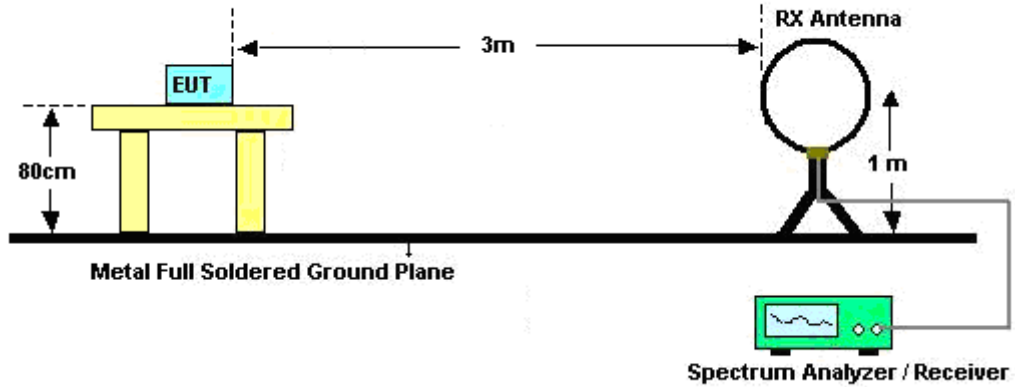

For radiated emissions from 30MHz to 1GHz

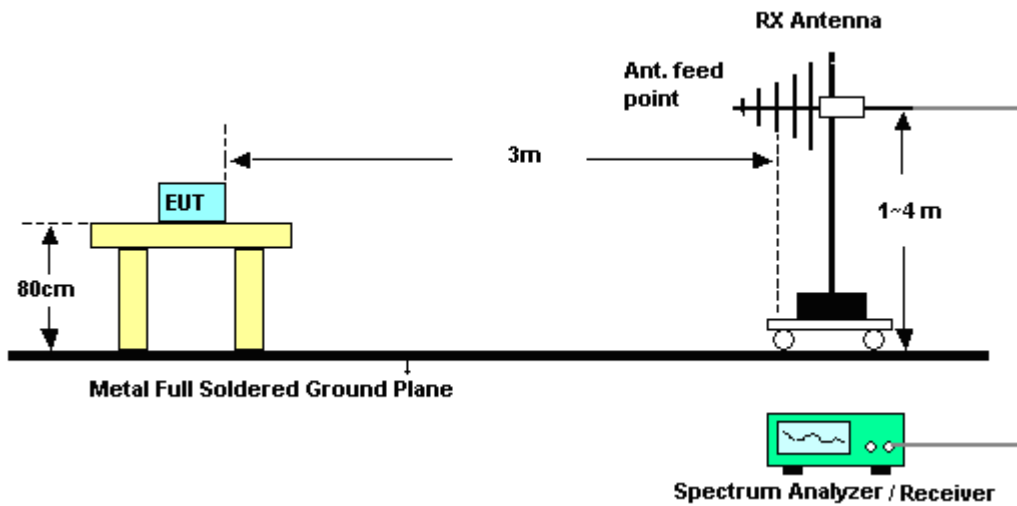

For radiated emissions above 1GHz

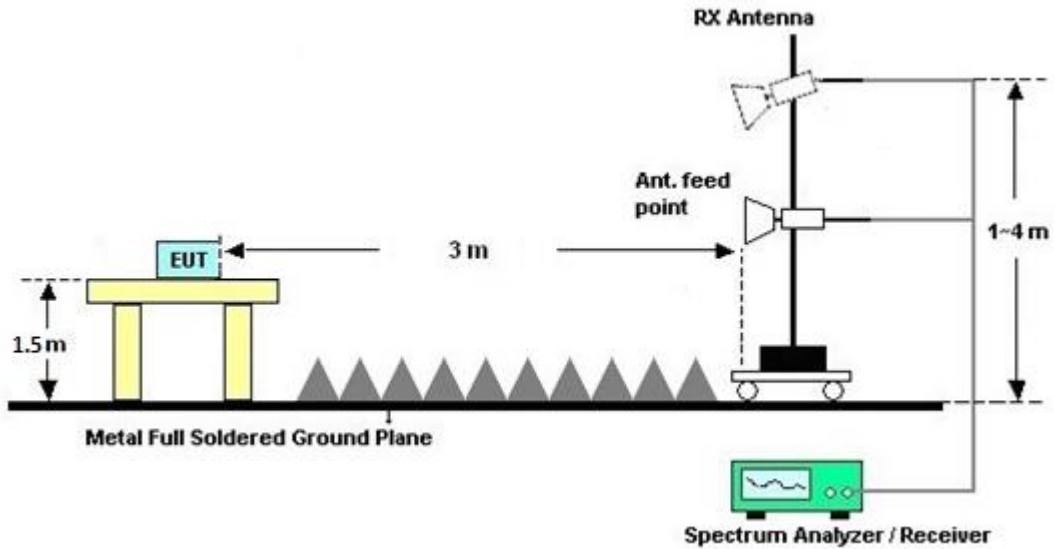

3.2.5 Test Results of Radiated Emissions (9kHz ~ 30MHz)

The low frequency, which started from 9 kHz to 30MHz, was pre-scanned and the result which was 20dB lower than the limit line per 15.31(o) was not reported.

3.2.6 Test Result of Radiated Spurious at Band Edges

Please refer to Appendix B and C.

3.2.7 Duty Cycle

Please refer to Appendix D.

3.2.8 Test Result of Radiated Spurious Emission (30MHz ~ 10th Harmonic)

Please refer to Appendix B and C.



3.3 Antenna Requirements

3.3.1 Standard Applicable

If directional gain of transmitting Antennas is greater than 6dBi, the power shall be reduced by the same level in dB comparing to gain minus 6dBi. For the fixed point-to-point operation, the power shall be reduced by one dB for every 3 dB that the directional gain of the Antenna exceeds 6 dBi. The use of a permanently attached Antenna or of an Antenna that uses a unique coupling to the intentional radiator shall be considered sufficient to comply with the FCC rule.

3.3.2 Antenna Anti-Replacement Construction

An embedded-in antenna design is used.

3.3.3 Antenna Gain

The antenna peak gain of EUT is less than 6 dBi. Therefore, it is not necessary to reduce maximum peak output power limit.



4 List of Measuring Equipment

Instrument	Manufacturer	Model No.	Serial No.	Characteristics	Calibration Date	Test Date	Due Date	Remark
Power Meter	Anritsu	ML2495A	1132003	300MHz~40GHz	Aug. 04, 2016	Oct. 03, 2016 ~ Dec. 02, 2016	Aug. 03, 2017	Conducted (TH05-HY)
Power Sensor	Anritsu	MA2411B	1126017	300MHz~40GHz	Aug. 04, 2016	Oct. 03, 2016 ~ Dec. 02, 2016	Aug. 03, 2017	Conducted (TH05-HY)
Loop Antenna	Rohde & Schwarz	HFH2-Z2	100315	9 kHz~30 MHz	Sep. 02, 2015	Oct. 12, 2016 ~ Oct. 14, 2016	Sep. 01, 2017	Radiation (03CH13-HY)
Amplifier	Sonoma-Instrument	310 N	187282	10MHz~1GHz	Dec. 31, 2015	Oct. 12, 2016 ~ Oct. 14, 2016	Dec. 30, 2016	Radiation (03CH13-HY)
Bilog Antenna	TESEQ	CBL 6111D&00800 N1D01N-06	40103&04	30MHz to 1GHz	Jan. 13, 2016	Oct. 12, 2016 ~ Oct. 14, 2016	Jan. 12, 2017	Radiation (03CH13-HY)
EMI Test Receiver	Keysight	N9038A (MXE)	MY554201 70	N/A	Mar. 10, 2016	Oct. 12, 2016 ~ Oct. 14, 2016	Mar. 09, 2017	Radiation (03CH13-HY)
Horn Antenna	SCHWARZBECK	BBHA 9120 D	9120D-124 1	1GHz ~ 18GHz	Apr. 25, 2016	Oct. 12, 2016 ~ Oct. 14, 2016	Apr. 24, 2017	Radiation (03CH13-HY)
Preamplifier	MITEQ	AMF-7D-0010 1800-30-10P	1590074	1GHz~18GHz	Jun. 27, 2016	Oct. 12, 2016 ~ Oct. 14, 2016	Jun. 26, 2017	Radiation (03CH13-HY)
Preamplifier	MITEQ	JS44-180040 00-33-8P	1840917	18GHz ~ 40GHz	Jun. 14, 2016	Oct. 12, 2016 ~ Oct. 14, 2016	Jun. 13, 2017	Radiation (03CH13-HY)
Preamplifier	Keysight	83017A	MY532701 47	1GHz~26.5GHz	Jan. 30, 2016	Oct. 12, 2016 ~ Oct. 14, 2016	Jan. 29, 2017	Radiation (03CH13-HY)
Spectrum Analyzer	Keysight	N9010A	MY553705 26	N/A	Mar. 14, 2016	Oct. 12, 2016 ~ Oct. 14, 2016	Mar. 13, 2017	Radiation (03CH13-HY)
Antenna Mast	EMEC	AM-BS-4500- B	N/A	1m~4m	N/A	Oct. 12, 2016 ~ Oct. 14, 2016	N/A	Radiation (03CH13-HY)
Turn Table	EMEC	TT2000	N/A	0~360 Degree	N/A	Oct. 12, 2016 ~ Oct. 14, 2016	N/A	Radiation (03CH13-HY)
SHF-EHF Horn Antenna	SCHWARZBECK	BBHA 9170	BBHA9170 584	18GHz- 40GHz	Nov. 02, 2015	Oct. 12, 2016 ~ Oct. 14, 2016	Nov. 01, 2016	Radiation (03CH13-HY)



5 Uncertainty of Evaluation

Uncertainty of Radiated Emission Measurement (30 MHz ~ 1000 MHz)

Measuring Uncertainty for a Level of Confidence of 95% ($U = 2Uc(y)$)	4.9
---	-----

Uncertainty of Radiated Emission Measurement (1000 MHz ~ 18000 MHz)

Measuring Uncertainty for a Level of Confidence of 95% ($U = 2Uc(y)$)	5.4
---	-----

Uncertainty of Radiated Emission Measurement (18000 MHz ~ 40000 MHz)

Measuring Uncertainty for a Level of Confidence of 95% ($U = 2Uc(y)$)	4.3
---	-----



Appendix A. Conducted Test Results

Test Engineer:	Derek Hsu / Tomm Lee	Temperature:	21~25	°C
Test Date:	2016/10/03~2016/11/15	Relative Humidity:	51~54	%

TEST RESULTS DATA
Peak Output Power

2.4GHz Band																
Mod.	Data Rate	NTX	CH.	Freq. (MHz)	Peak Conducted Power (dBm)			Conducted Power Limit (dBm)		DG (dBi)		EIRP Power (dBm)		EIRP Power Limit (dBm)		Pass /Fail
					Ant 1	Ant 2	SUM	Ant 1	Ant 2	Ant 1	Ant 2	Ant 1	Ant 2	Ant 1	Ant 2	
11b	1Mbps	1	1	2412	22.90	24.10		30.00	30.00	1.47	2.36	24.37	26.46	36.00	36.00	Pass
11b	1Mbps	1	6	2437	22.81	23.95		30.00	30.00	1.47	2.36	24.28	26.31	36.00	36.00	Pass
11b	1Mbps	1	11	2462	22.59	22.91		30.00	30.00	1.47	2.36	24.06	25.27	36.00	36.00	Pass
11g	6Mbps	1	1	2412	24.15	24.19		30.00	30.00	1.47	2.36	25.62	26.55	36.00	36.00	Pass
11g	6Mbps	1	6	2437	25.00	25.21		30.00	30.00	1.47	2.36	26.47	27.57	36.00	36.00	Pass
11g	6Mbps	1	11	2462	23.95	23.66		30.00	30.00	1.47	2.36	25.42	26.02	36.00	36.00	Pass
HT20	MCS0	1	1	2412	23.88	23.06		30.00	30.00	1.47	2.36	25.35	25.42	36.00	36.00	Pass
HT20	MCS0	1	6	2437	24.94	25.16		30.00	30.00	1.47	2.36	26.41	27.52	36.00	36.00	Pass
HT20	MCS0	1	11	2462	23.20	23.23		30.00	30.00	1.47	2.36	24.67	25.59	36.00	36.00	Pass

Note: Measured power (dBm) has offset with cable loss.

TEST RESULTS DATA
Average Output Power

2.4GHz Band									
Mod.	Data Rate	NTX	CH.	Freq. (MHz)	Duty Factor (dB)		Average Conducted Power (dBm)		
					Ant 1	Ant 2	Ant 1	Ant 2	SUM
11b	1Mbps	1	1	2412	0.10	0.10	20.38	21.89	
11b	1Mbps	1	6	2437	0.10	0.10	20.42	21.91	
11b	1Mbps	1	11	2462	0.10	0.10	20.31	20.80	
11g	6Mbps	1	1	2412	0.53	0.59	16.78	16.49	
11g	6Mbps	1	6	2437	0.53	0.59	19.69	19.94	
11g	6Mbps	1	11	2462	0.53	0.59	16.49	15.67	
HT20	MCS0	1	1	2412	0.56	0.56	15.96	13.89	
HT20	MCS0	1	6	2437	0.56	0.56	19.77	19.98	
HT20	MCS0	1	11	2462	0.56	0.56	14.91	14.73	

Note: Measured power (dBm) has offset with cable loss.



Appendix B. Radiated Spurious Emission

Test Engineer :	Alex Wang, Bill Kuo, and Kyle Jhuang	Temperature :	22~24°C
		Relative Humidity :	53~56%

<Ant. 1>

2.4GHz 2400~2483.5MHz

WIFI 802.11b (Band Edge @ 3m)

WIFI Ant. 1	Note	Frequency (MHz)	Level (dBμV/m)	Over Limit (dB)	Limit Line (dBμV/m)	Read Level (dBμV)	Antenna Factor (dB/m)	Cable Loss (dB)	Preamp Factor (dB)	Ant Pos (cm)	Table Pos (deg)	Peak Avg. (P/A)	Pol. (H/V)	
802.11b CH 01 2412MHz		2386.755	54.39	-19.61	74	51.54	27.15	6.98	31.28	147	91	P	H	
		2387.175	45.35	-8.65	54	42.5	27.15	6.98	31.28	147	91	A	H	
		2412	109.61	-	-	106.69	27.19	7	31.27	147	91	P	H	
		2412	106.58	-	-	103.66	27.19	7	31.27	147	91	A	H	
													H	
			2382.555	54.21	-19.79	74	51.42	27.11	6.96	31.28	117	335	P	V
			2387.07	45.9	-8.1	54	43.05	27.15	6.98	31.28	117	335	A	V
			2412	108.15	-	-	105.23	27.19	7	31.27	117	335	P	V
			2412	104.95	-	-	102.03	27.19	7	31.27	117	335	A	V
														V
802.11b CH 11 2462MHz		2462	108.4	-	-	105.29	27.32	7.05	31.26	107	86	P	H	
		2462	105.25	-	-	102.14	27.32	7.05	31.26	107	86	A	H	
		2488.08	55.26	-18.74	74	52.02	27.4	7.09	31.25	107	86	P	H	
		2488.04	47.04	-6.96	54	43.8	27.4	7.09	31.25	107	86	A	H	
													H	
			2462	108.59	-	-	105.48	27.32	7.05	31.26	100	349	P	V
			2462	105.43	-	-	102.32	27.32	7.05	31.26	100	349	A	V
			2487.92	56.2	-17.8	74	52.96	27.4	7.09	31.25	100	349	P	V
			2487.84	46.78	-7.22	54	43.54	27.4	7.09	31.25	100	349	A	V
														V

Remark	1. No other spurious found.
	2. All results are PASS against Peak and Average limit line.



2.4GHz 2400~2483.5MHz

WIFI 802.11b (Harmonic @ 3m)

WIFI Ant. 1	Note	Frequency (MHz)	Level (dBμV/m)	Over Limit (dB)	Limit Line (dBμV/m)	Read Level (dBμV)	Antenna Factor (dB/m)	Cable Loss (dB)	Preamp Factor (dB)	Ant Pos (cm)	Table Pos (deg)	Peak Avg. (P/A)	Pol. (H/V)	
802.11b CH 06 2437MHz		4874	48.31	-25.69	74	63.36	31.31	10.11	56.47	100	0	P	H	
		7311	45.53	-28.47	74	53.93	36.27	12.53	57.2	100	0	P	H	
													H	
													H	
													V	
			4874	47.68	-26.32	74	62.73	31.31	10.11	56.47	100	0	P	V
			7311	44.38	-29.62	74	52.78	36.27	12.53	57.2	100	0	P	V
														V
Remark	1. No other spurious found. 2. All results are PASS against Peak and Average limit line.													



2.4GHz 2400~2483.5MHz

WIFI 802.11g (Band Edge @ 3m)

WIFI Ant. 1	Note	Frequency (MHz)	Level (dBμV/m)	Over Limit (dB)	Limit Line (dBμV/m)	Read Level (dBμV)	Antenna Factor (dB/m)	Cable Loss (dB)	Preamp Factor (dB)	Ant Pos (cm)	Table Pos (deg)	Peak Avg. (P/A)	Pol. (H/V)	
802.11g CH 01 2412MHz		2389.905	63.28	-10.72	74	60.42	27.15	6.98	31.27	100	91	P	H	
		2389.8	50.66	-3.34	54	47.8	27.15	6.98	31.27	100	91	A	H	
		2412	108.98	-	-	106.06	27.19	7	31.27	100	91	P	H	
		2412	100.54	-	-	97.62	27.19	7	31.27	100	91	A	H	
													H	
													H	
			2389.695	63.8	-10.2	74	60.95	27.15	6.98	31.28	114	336	P	V
			2389.905	51.39	-2.61	54	48.53	27.15	6.98	31.27	114	336	A	V
			2412	108.92	-	-	106	27.19	7	31.27	114	336	P	V
			2412	100.51	-	-	97.59	27.19	7	31.27	114	336	A	V
													V	
													V	
802.11g CH 11 2462MHz		2462	108.72	-	-	105.61	27.32	7.05	31.26	110	97	P	H	
		2462	101.23	-	-	98.12	27.32	7.05	31.26	110	97	A	H	
		2483.96	67.73	-6.27	74	64.55	27.36	7.07	31.25	110	97	P	H	
		2483.52	52.88	-1.12	54	49.7	27.36	7.07	31.25	110	97	A	H	
													H	
													H	
			2462	108.67	-	-	105.56	27.32	7.05	31.26	100	184	P	V
			2462	101.8	-	-	98.69	27.32	7.05	31.26	100	184	A	V
			2483.76	65.91	-8.09	74	62.73	27.36	7.07	31.25	100	184	P	V
			2483.52	53.12	-0.88	54	49.94	27.36	7.07	31.25	100	184	A	V
													V	
													V	
Remark	1. No other spurious found. 2. All results are PASS against Peak and Average limit line.													



2.4GHz 2400~2483.5MHz

WIFI 802.11n HT20 (Band Edge @ 3m)

WIFI Ant. 1	Note	Frequency (MHz)	Level (dBμV/m)	Over Limit (dB)	Limit Line (dBμV/m)	Read Level (dBμV)	Antenna Factor (dB/m)	Cable Loss (dB)	Preamp Factor (dB)	Ant Pos (cm)	Table Pos (deg)	Peak Avg. (P/A)	Pol. (H/V)	
802.11n HT20 CH 01 2412MHz		2389.59	65.85	-8.15	74	63	27.15	6.98	31.28	382	272	P	H	
		2389.905	51.67	-2.33	54	48.81	27.15	6.98	31.27	382	272	A	H	
	*	2412	108.58	-	-	105.66	27.19	7	31.27	382	272	P	H	
	*	2412	101.53	-	-	98.61	27.19	7	31.27	382	272	A	H	
													H	
														H
			2390	66.65	-7.35	74	63.79	27.15	6.98	31.27	380	222	P	V
			2390	51.23	-2.77	54	48.37	27.15	6.98	31.27	380	222	A	V
			2412	108.71	-	-	105.79	27.19	7	31.27	380	222	P	V
			2412	101.1	-	-	98.18	27.19	7	31.27	380	222	A	V
802.11n HT20 CH 11 2462MHz	*	2462	109.3	-	-	106.19	27.32	7.05	31.26	362	111	P	H	
	*	2462	101.85	-	-	98.74	27.32	7.05	31.26	362	111	A	H	
		2483.6	67.63	-6.37	74	64.45	27.36	7.07	31.25	362	111	P	H	
		2483.52	51.91	-2.09	54	48.73	27.36	7.07	31.25	362	111	A	H	
													H	
														H
	*	2462	106.31	-	-	103.2	27.32	7.05	31.26	253	186	P	V	
	*	2462	98.9	-	-	95.79	27.32	7.05	31.26	253	186	A	V	
			2483.76	65.34	-8.66	74	62.16	27.36	7.07	31.25	253	186	P	V
			2483.52	49.83	-4.17	54	46.65	27.36	7.07	31.25	253	186	A	V
													V	
													V	
Remark	1. No other spurious found. 2. All results are PASS against Peak and Average limit line.													



Emission below 1GHz

2.4GHz WIFI 802.11n HT20 (LF)

WIFI	Note	Frequency	Level	Over	Limit	Read	Antenna	Cable	Preamp	Ant	Table	Peak	Pol.	
Ant.				Limit	Line	Level	Factor	Loss	Factor	Pos	Pos	Avg.		
1		(MHz)	(dBμV/m)	(dB)	(dBμV/m)	(dBμV)	(dB/m)	(dB)	(dB)	(cm)	(deg)	(P/A)	(H/V)	
2.4GHz 802.11n HT20 LF		55.11	32.41	-7.59	40	50.22	13.3	0.81	31.92	125	40	P	H	
		120.72	22.98	-20.52	43.5	36.17	17.52	1.16	31.87	-	-	P	H	
		182.28	27.69	-15.81	43.5	42.77	15.32	1.42	31.82	-	-	P	H	
		537.3	24.5	-21.5	46	29.55	24.22	2.62	31.89	-	-	P	H	
		691.3	27	-19	46	30.01	26.03	2.98	32.02	-	-	P	H	
		960.8	33.48	-20.52	54	30.89	30.15	3.47	31.03	-	-	P	H	
														H
														H
														H
														H
														H
														H
			55.11	36.22	-3.78	40	54.03	13.3	0.81	31.92	130	18	P	V
			97.5	28.8	-14.7	43.5	43.83	15.84	1.02	31.89	-	-	P	V
			198.48	23.34	-20.16	43.5	38.25	15.4	1.5	31.81	-	-	P	V
			493.9	24.47	-21.53	46	30	23.85	2.47	31.85	-	-	P	V
			681.5	27.33	-18.67	46	30.43	25.95	2.96	32.01	-	-	P	V
			955.2	31.93	-14.07	46	29.44	30.12	3.45	31.08	-	-	P	V
													V	
													V	
													V	
													V	
													V	
													V	
Remark	1. No other spurious found. 2. All results are PASS against limit line.													



<Ant. 2>

2.4GHz 2400~2483.5MHz

WIFI 802.11b (Band Edge @ 3m)

WIFI Ant. 2	Note	Frequency (MHz)	Level (dBμV/m)	Over Limit (dB)	Limit Line (dBμV/m)	Read Level (dBμV)	Antenna Factor (dB/m)	Cable Loss (dB)	Preamp Factor (dB)	Ant Pos (cm)	Table Pos (deg)	Peak Avg. (P/A)	Pol. (H/V)	
802.11b CH 01 2412MHz		2389.905	57.54	-16.46	74	54.68	27.15	6.98	31.27	100	89	P	H	
		2390	51.56	-2.44	54	48.7	27.15	6.98	31.27	100	89	A	H	
		2412	109.17	-	-	106.25	27.19	7	31.27	100	89	P	H	
		2412	106.09	-	-	103.17	27.19	7	31.27	100	89	A	H	
													H	
													H	
			2389.905	57.23	-16.77	74	54.37	27.15	6.98	31.27	104	179	P	V
			2390	51.23	-2.77	54	48.37	27.15	6.98	31.27	104	179	A	V
			2412	107.88	-	-	104.96	27.19	7	31.27	104	179	P	V
			2412	104.72	-	-	101.8	27.19	7	31.27	104	179	A	V
802.11b CH 11 2462MHz		2462	110.58	-	-	107.47	27.32	7.05	31.26	106	88	P	H	
		2462	107.41	-	-	104.3	27.32	7.05	31.26	106	88	A	H	
		2484.32	58.34	-15.66	74	55.16	27.36	7.07	31.25	106	88	P	H	
		2483.52	51.03	-2.97	54	47.85	27.36	7.07	31.25	106	88	A	H	
													H	
													H	
			2462	106.1	-	-	102.99	27.32	7.05	31.26	100	213	P	V
			2462	103	-	-	99.89	27.32	7.05	31.26	100	213	A	V
			2483.56	56.53	-17.47	74	53.35	27.36	7.07	31.25	100	213	P	V
			2483.52	48.54	-5.46	54	45.36	27.36	7.07	31.25	100	213	A	V
												V		
												V		
Remark	3. No other spurious found. 4. All results are PASS against Peak and Average limit line.													



2.4GHz 2400~2483.5MHz

WIFI 802.11b (Harmonic @ 3m)

WIFI Ant. 2	Note	Frequency (MHz)	Level (dBμV/m)	Over Limit (dB)	Limit Line (dBμV/m)	Read Level (dBμV)	Antenna Factor (dB/m)	Cable Loss (dB)	Preamp Factor (dB)	Ant Pos (cm)	Table Pos (deg)	Peak Avg. (P/A)	Pol. (H/V)	
802.11b CH 06 2437MHz		4874	50.39	-23.61	74	65.44	31.31	10.11	56.47	339	169	P	H	
		4874	48.23	-5.77	54	63.28	31.31	10.11	56.47	339	169	A	H	
		7311	44.15	-29.85	74	52.55	36.27	12.53	57.2	100	0	P	H	
													H	
													V	
			4874	48.6	-25.4	74	63.65	31.31	10.11	56.47	100	0	P	V
			7311	46.95	-27.05	74	55.35	36.27	12.53	57.2	100	0	P	V
													V	
Remark	3. No other spurious found. 4. All results are PASS against Peak and Average limit line.													



2.4GHz 2400~2483.5MHz

WIFI 802.11g (Band Edge @ 3m)

WIFI Ant. 2	Note	Frequency (MHz)	Level (dBμV/m)	Over Limit (dB)	Limit Line (dBμV/m)	Read Level (dBμV)	Antenna Factor (dB/m)	Cable Loss (dB)	Preamp Factor (dB)	Ant Pos (cm)	Table Pos (deg)	Peak Avg. (P/A)	Pol. (H/V)	
802.11g CH 01 2412MHz		2389.38	65.51	-8.49	74	62.66	27.15	6.98	31.28	100	113	P	H	
		2390	53.39	-0.61	54	50.53	27.15	6.98	31.27	100	113	A	H	
		2412	106.47	-	-	103.55	27.19	7	31.27	100	113	P	H	
		2412	99.2	-	-	96.28	27.19	7	31.27	100	113	A	H	
													H	
													H	
			2390	65.9	-8.1	74	63.04	27.15	6.98	31.27	131	176	P	V
			2390	52.21	-1.79	54	49.35	27.15	6.98	31.27	131	176	A	V
			2412	105.96	-	-	103.04	27.19	7	31.27	131	176	P	V
			2412	98.67	-	-	95.75	27.19	7	31.27	131	176	A	V
													V	
													V	
802.11g CH 11 2462MHz		2462	108.1	-	-	104.99	27.32	7.05	31.26	103	88	P	H	
		2462	100.83	-	-	97.72	27.32	7.05	31.26	103	88	A	H	
		2483.52	65.59	-8.41	74	62.41	27.36	7.07	31.25	103	88	P	H	
		2483.64	52.26	-1.74	54	49.08	27.36	7.07	31.25	103	88	A	H	
													H	
													H	
			2462	105.17	-	-	102.06	27.32	7.05	31.26	100	198	P	V
			2462	97.8	-	-	94.69	27.32	7.05	31.26	100	198	A	V
			2483.52	64.64	-9.36	74	61.46	27.36	7.07	31.25	100	198	P	V
			2483.52	49.72	-4.28	54	46.54	27.36	7.07	31.25	100	198	A	V
													V	
													V	
Remark	<p>3. No other spurious found.</p> <p>4. All results are PASS against Peak and Average limit line.</p>													



2.4GHz 2400~2483.5MHz

WIFI 802.11n HT20 (Band Edge @ 3m)

WIFI Ant. 2	Note	Frequency (MHz)	Level (dBμV/m)	Over Limit (dB)	Limit Line (dBμV/m)	Read Level (dBμV)	Antenna Factor (dB/m)	Cable Loss (dB)	Preamp Factor (dB)	Ant Pos (cm)	Table Pos (deg)	Peak Avg. (P/A)	Pol. (H/V)	
802.11n HT20 CH 01 2412MHz		2389.8	60.77	-13.23	74	57.91	27.15	6.98	31.27	383	100	P	H	
		2390	48.94	-5.06	54	46.08	27.15	6.98	31.27	383	100	A	H	
	*	2412	105.56	-	-	102.64	27.19	7	31.27	383	100	P	H	
	*	2412	98.14	-	-	95.22	27.19	7	31.27	383	100	A	H	
													H	
														H
			2390	64.57	-9.43	74	61.71	27.15	6.98	31.27	380	168	P	V
			2390	51.03	-2.97	54	48.17	27.15	6.98	31.27	380	168	A	V
		*	2412	107.11	-	-	104.19	27.19	7	31.27	380	168	P	V
		*	2412	99.59	-	-	96.67	27.19	7	31.27	380	168	A	V
802.11n HT20 CH 11 2462MHz													V	
													V	
		*	2462	107.17	-	-	104.06	27.32	7.05	31.26	359	97	P	H
		*	2462	99.68	-	-	96.57	27.32	7.05	31.26	359	97	A	H
			2483.68	65.84	-8.16	74	62.66	27.36	7.07	31.25	359	97	P	H
			2483.8	52.52	-1.48	54	49.34	27.36	7.07	31.25	359	97	A	H
														H
														H
		*	2462	108.04	-	-	104.93	27.32	7.05	31.26	400	157	P	V
		*	2462	100.27	-	-	97.16	27.32	7.05	31.26	400	157	A	V
		2484.2	65.88	-8.12	74	62.7	27.36	7.07	31.25	400	157	P	V	
		2483.68	52.76	-1.24	54	49.58	27.36	7.07	31.25	400	157	A	V	
													V	
													V	
Remark	<p>3. No other spurious found.</p> <p>4. All results are PASS against Peak and Average limit line.</p>													



Emission below 1GHz

2.4GHz WIFI 802.11n HT20 (LF)

WIFI	Note	Frequency	Level	Over	Limit	Read	Antenna	Cable	Preamp	Ant	Table	Peak	Pol.	
Ant.				Limit	Line	Level	Factor	Loss	Factor	Pos	Pos	Avg.		
2		(MHz)	(dBμV/m)	(dB)	(dBμV/m)	(dBμV)	(dB/m)	(dB)	(dB)	(cm)	(deg)	(P/A)	(H/V)	
2.4GHz 802.11n HT20 LF		39.72	35.1	-4.9	40	46.22	20.2	0.61	31.93	125	45	P	H	
		89.13	26.96	-16.54	43.5	43.16	14.69	1.01	31.9	-	-	P	H	
		184.44	27.44	-16.06	43.5	42.49	15.34	1.43	31.82	-	-	P	H	
		579.3	25.59	-20.41	46	29.91	24.88	2.73	31.93	-	-	P	H	
		712.3	27.48	-18.52	46	30.07	26.41	3.02	32.02	-	-	P	H	
		934.9	30.95	-15.05	46	29.01	29.75	3.44	31.25	-	-	P	H	
														H
														H
														H
														H
														H
														H
			39.99	36.01	-3.99	40	47.13	20.2	0.61	31.93	130	20	P	V
			127.2	26.46	-17.04	43.5	39.5	17.64	1.19	31.87	-	-	P	V
			177.15	24.01	-19.49	43.5	38.98	15.46	1.4	31.83	-	-	P	V
			512.8	24.47	-21.53	46	29.72	24.08	2.54	31.87	-	-	P	V
			710.9	27.28	-18.72	46	29.9	26.38	3.02	32.02	-	-	P	V
			925.1	30.81	-15.19	46	29.19	29.51	3.44	31.33	-	-	P	V
													V	
													V	
													V	
													V	
													V	
													V	
Remark	3. No other spurious found. 4. All results are PASS against limit line.													



Note symbol

*	Fundamental Frequency which can be ignored. However, the level of any unwanted emissions shall not exceed the level of the fundamental frequency.
!	Test result is over limit line.
P/A	Peak or Average
H/V	Horizontal or Vertical



A calculation example for radiated spurious emission is shown as below:

WIFI	Note	Frequency	Level	Over	Limit	Read	Antenna	Cable	Preamp	Ant	Table	Peak	Pol.
Ant.				Limit	Line	Level	Factor	Loss	Factor	Pos	Pos	Avg.	
1		(MHz)	(dBμV/m)	(dB)	(dBμV/m)	(dBμV)	(dB/m)	(dB)	(dB)	(cm)	(deg)	(P/A)	(H/V)
802.11b		2390	55.45	-18.55	74	54.51	32.22	4.58	35.86	103	308	P	H
CH 01													
2412MHz		2390	43.54	-10.46	54	42.6	32.22	4.58	35.86	103	308	A	H

- 1. Level(dBμV/m) =
Antenna Factor(dB/m) + Cable Loss(dB) + Read Level(dBμV) - Preamp Factor(dB)
- 2. Over Limit(dB) = Level(dBμV/m) – Limit Line(dBμV/m)

For Peak Limit @ 2390MHz:

- 1. Level(dBμV/m)
= Antenna Factor(dB/m) + Cable Loss(dB) + Read Level(dBμV) - Preamp Factor(dB)
= 32.22(dB/m) + 4.58(dB) + 54.51(dBμV) – 35.86 (dB)
= 55.45 (dBμV/m)
- 2. Over Limit(dB)
= Level(dBμV/m) – Limit Line(dBμV/m)
= 55.45(dBμV/m) – 74(dBμV/m)
= -18.55(dB)

For Average Limit @ 2390MHz:

- 1. Level(dBμV/m)
= Antenna Factor(dB/m) + Cable Loss(dB) + Read Level(dBμV) - Preamp Factor(dB)
= 32.22(dB/m) + 4.58(dB) + 42.6(dBμV) – 35.86 (dB)
= 43.54 (dBμV/m)
- 2. Over Limit(dB)
= Level(dBμV/m) – Limit Line(dBμV/m)
= 43.54(dBμV/m) – 54(dBμV/m)
= -10.46(dB)

Both peak and average measured complies with the limit line, so test result is “PASS”.



Appendix C. Radiated Spurious Emission Plots

Test Engineer :	Alex Wang, Bill Kuo, and Kyle Jhuang	Temperature :	22~24°C
		Relative Humidity :	53~56%

Note symbol

-L	Low channel location
-R	High channel location



<Ant. 1>

2.4GHz 2400~2483.5MHz

WIFI 802.11b (Band Edge @ 3m)

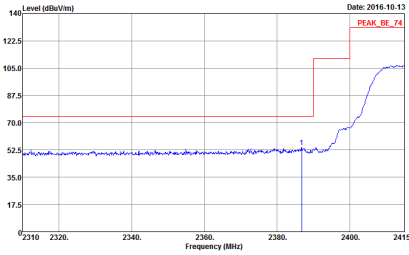
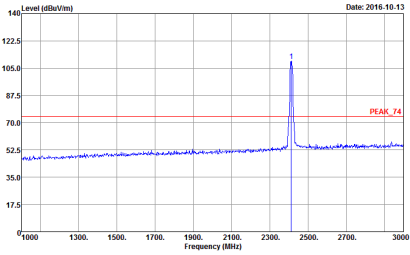
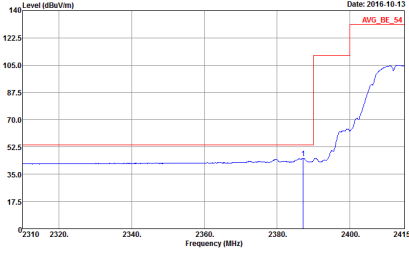
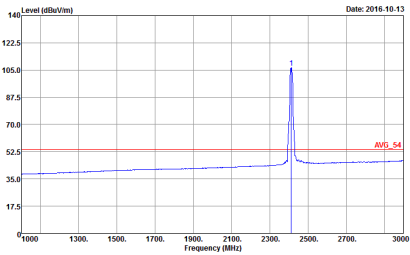
WIFI	2.4GHz 2400~2483.5MHz Band Edge @ 3m	
ANT	802.11b CH01 2412MHz	
1	Horizontal	Fundamental
Peak	 <p>Date: 2016-10-13 PEAK_BE_74</p> <p>Site : 03CH13-HY Condition : PEAK_BE_74 3m HORN_9120D_1241 HORIZONTAL Detector : Peak Project : 631725-02 Mode : 1</p>	 <p>Date: 2016-10-13 PEAK_24</p> <p>Site : 03CH13-HY Condition : PEAK_74 3m HORN_9120D_1241 HORIZONTAL Detector : Peak Project : 631725-02 Mode : 1</p>
Avg.	 <p>Date: 2016-10-13 AVG_BE_54</p> <p>Site : 03CH13-HY Condition : AVG_BE_54 3m HORN_9120D_1241 HORIZONTAL Detector : Peak Project : 631725-02 Mode : 1</p>	 <p>Date: 2016-10-13 AVG_54</p> <p>Site : 03CH13-HY Condition : AVG_54 3m HORN_9120D_1241 HORIZONTAL Detector : Peak Project : 631725-02 Mode : 1</p>

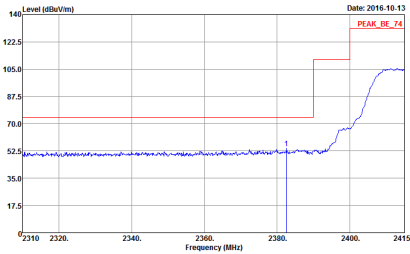
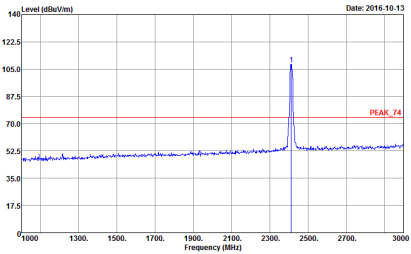
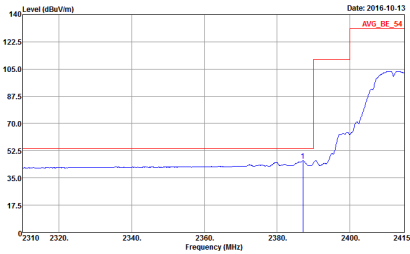
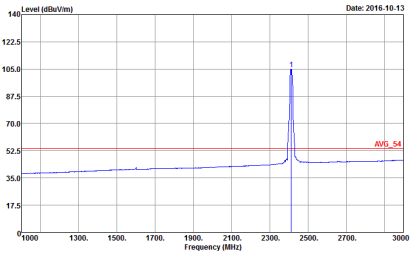

WIFI	2.4GHz 2400~2483.5MHz Band Edge @ 3m	
ANT	802.11b CH01 2412MHz	
1	<p style="text-align: center;">Vertical</p>  <p>Date: 2016-10-13 PEAK_BE_74</p> <p>Site : 03CH13-HY Condition : PEAK_BE_74 3m HORN_9120D_1241 VERTICAL RBW:1000.000KHz VBW:3000.000KHz SWT:Auto Detector : Peak Project : 631725-02 Mode : 1</p>	<p style="text-align: center;">Fundamental</p>  <p>Date: 2016-10-13 PEAK_74</p> <p>Site : 03CH13-HY Condition : PEAK_74 3m HORN_9120D_1241 VERTICAL RBW:1000.000KHz VBW:3000.000KHz SWT:Auto Detector : Peak Project : 631725-02 Mode : 1</p>
Avg.	 <p>Date: 2016-10-13 AVG_BE_54</p> <p>Site : 03CH13-HY Condition : AVG_BE_54 3m HORN_9120D_1241 VERTICAL RBW:1000.000KHz VBW:0.300KHz SWT:Auto Detector : Peak Project : 631725-02 Mode : 1</p>	 <p>Date: 2016-10-13 AVG_54</p> <p>Site : 03CH13-HY Condition : AVG_54 3m HORN_9120D_1241 VERTICAL RBW:1000.000KHz VBW:0.300KHz SWT:Auto Detector : Peak Project : 631725-02 Mode : 1</p>

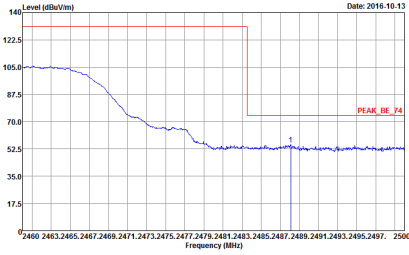
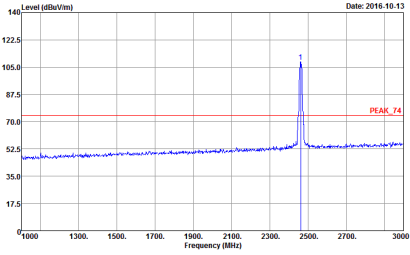
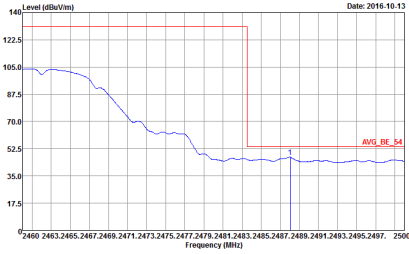
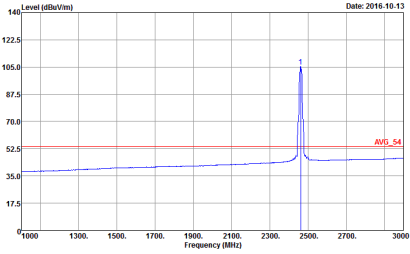

WIFI	2.4GHz 2400~2483.5MHz Band Edge @ 3m	
ANT	802.11b CH11 2462MHz	
1	Horizontal	Fundamental
Peak	 <p>Date: 2016-10-13</p> <p>Site : 03CH13-HY Condition : PEAK_BE_74 3m HORN_91200_1241 HORIZONTAL : RBW:1000.000KHz VBW:3000.000KHz SWT:Auto Detector : Peak Project : 631725-02 Mode : 5</p>	 <p>Date: 2016-10-13</p> <p>Site : 03CH13-HY Condition : PEAK_74 3m HORN_91200_1241 HORIZONTAL : RBW:1000.000KHz VBW:3000.000KHz SWT:Auto Detector : Peak Project : 631725-02 Mode : 5</p>
Avg.	 <p>Date: 2016-10-13</p> <p>Site : 03CH13-HY Condition : AVG_BE_54 3m HORN_91200_1241 HORIZONTAL : RBW:1000.000KHz VBW:0.300KHz SWT:Auto Detector : Peak Project : 631725-02 Mode : 5</p>	 <p>Date: 2016-10-13</p> <p>Site : 03CH13-HY Condition : AVG_54 3m HORN_91200_1241 HORIZONTAL : RBW:1000.000KHz VBW:0.300KHz SWT:Auto Detector : Peak Project : 631725-02 Mode : 5</p>

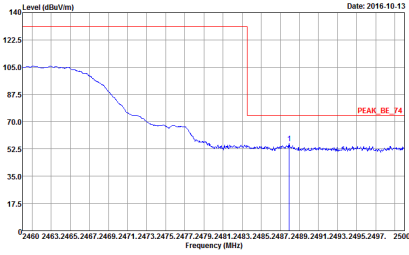
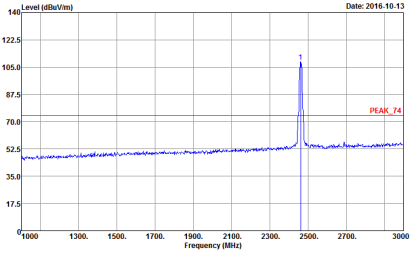
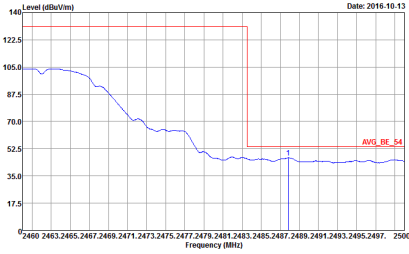
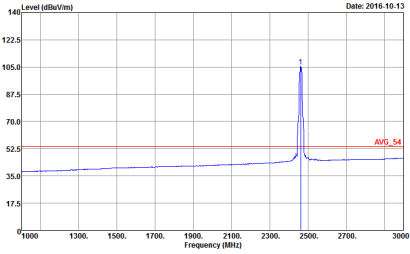

WIFI	2.4GHz 2400~2483.5MHz Band Edge @ 3m	
ANT	802.11b CH11 2462MHz	
1	<p style="text-align: center;">Vertical</p>  <p>Site : 03CH13-HY Condition : PEAK_BE_74 3m HORN_91200_1241 VERTICAL : RBW:1000.000KHz VBW:3000.000KHz SWT:Auto Detector : Peak Project : 631725-02 Mode : 5</p>	<p style="text-align: center;">Fundamental</p>  <p>Site : 03CH13-HY Condition : PEAK_74 3m HORN_91200_1241 VERTICAL : RBW:1000.000KHz VBW:3000.000KHz SWT:Auto Detector : Peak Project : 631725-02 Mode : 5</p>
Avg.	 <p>Site : 03CH13-HY Condition : AVG_BE_54 3m HORN_91200_1241 VERTICAL : RBW:1000.000KHz VBW:0.300KHz SWT:Auto Detector : Peak Project : 631725-02 Mode : 5</p>	 <p>Site : 03CH13-HY Condition : AVG_54 3m HORN_91200_1241 VERTICAL : RBW:1000.000KHz VBW:0.300KHz SWT:Auto Detector : Peak Project : 631725-02 Mode : 5</p>



2.4GHz 2400~2483.5MHz

WIFI 802.11g (Band Edge @ 3m)

WIFI	2.4GHz 2400~2483.5MHz Band Edge @ 3m	
ANT	802.11g CH01 2412MHz	
1	Horizontal	Fundamental
Peak	<p> Site : 03CH13-HY Condition : PEAK_BE_74 3m HORN_9120D_1241 HORIZONTAL : RBW:1000.000KHz VBW:3000.000KHz SWT:Auto Detector : Peak Project : 631725-02 Mode : 6 Power : 19 </p>	<p> Site : 03CH13-HY Condition : PEAK_74 3m HORN_9120D_1241 HORIZONTAL : RBW:1000.000KHz VBW:3000.000KHz SWT:Auto Detector : Peak Project : 631725-02 Mode : 6 Power : 19 </p>
Avg.	<p> Site : 03CH13-HY Condition : AVG_BE_54 3m HORN_9120D_1241 HORIZONTAL : RBW:1000.000KHz VBW:1.000KHz SWT:Auto Detector : Peak Project : 631725-02 Mode : 6 Power : 19 </p>	<p> Site : 03CH13-HY Condition : AVG_54 3m HORN_9120D_1241 HORIZONTAL : RBW:1000.000KHz VBW:1.000KHz SWT:Auto Detector : Peak Project : 631725-02 Mode : 6 Power : 19 </p>

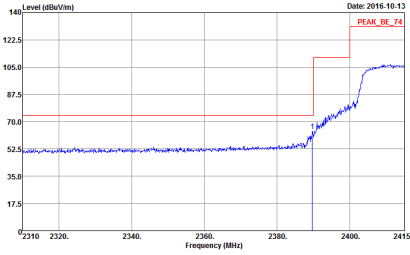
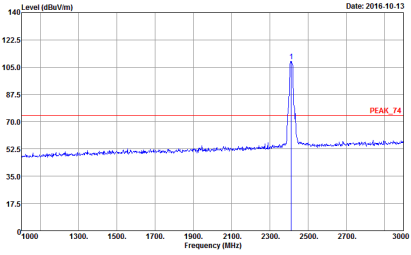
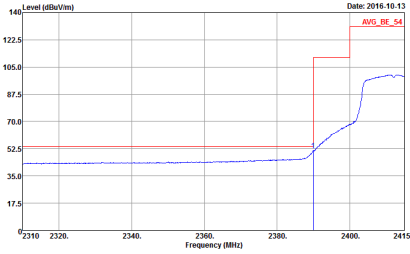
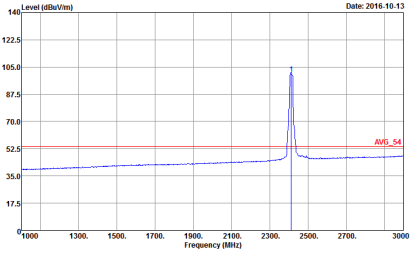

WIFI	2.4GHz 2400~2483.5MHz Band Edge @ 3m	
ANT	802.11g CH01 2412MHz	
1	Vertical	Fundamental
Peak	 <p>Date: 2016-10-13 PEAK_BE_74</p> <p>Site : 03CH13-HY Condition : PEAK_BE_74 3m HORN_91200_1241 VERTICAL RBW:1000.000KHz VBW:3000.000KHz SWT:Auto Detector : Peak Project : 631725-02 Mode : 6 Power : 19</p>	 <p>Date: 2016-10-13 PEAK_74</p> <p>Site : 03CH13-HY Condition : PEAK_74 3m HORN_91200_1241 VERTICAL RBW:1000.000KHz VBW:3000.000KHz SWT:Auto Detector : Peak Project : 631725-02 Mode : 6 Power : 19</p>
Avg.	 <p>Date: 2016-10-13 AVG_BE_54</p> <p>Site : 03CH13-HY Condition : AVG_BE_54 3m HORN_91200_1241 VERTICAL RBW:1000.000KHz VBW:1.000KHz SWT:Auto Detector : Peak Project : 631725-02 Mode : 6 Power : 19</p>	 <p>Date: 2016-10-13 AVG_54</p> <p>Site : 03CH13-HY Condition : AVG_54 3m HORN_91200_1241 VERTICAL RBW:1000.000KHz VBW:1.000KHz SWT:Auto Detector : Peak Project : 631725-02 Mode : 6 Power : 19</p>

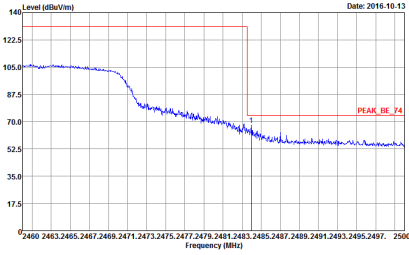
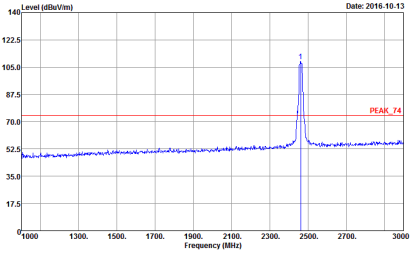
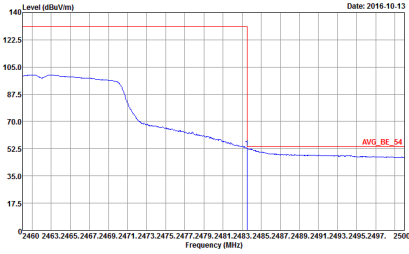
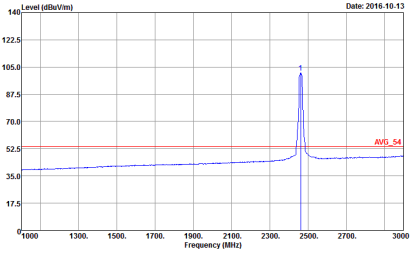

WIFI	2.4GHz 2400~2483.5MHz Band Edge @ 3m	
ANT	802.11g CH11 2462MHz	
1	Horizontal	Fundamental
Peak	 <p>Site : 03CH13-HY Condition : PEAK_BE_74 3m HORN_91200_1241 HORIZONTAL RBW:1000.000KHz VBW:3000.000KHz SWT:Auto Detector : Peak Project : 631725-02 Mode : 7</p>	 <p>Site : 03CH13-HY Condition : PEAK_74 3m HORN_91200_1241 HORIZONTAL RBW:1000.000KHz VBW:3000.000KHz SWT:Auto Detector : Peak Project : 631725-02 Mode : 7</p>
Avg.	 <p>Site : 03CH13-HY Condition : AVG_BE_54 3m HORN_91200_1241 HORIZONTAL RBW:1000.000KHz VBW:1000KHz SWT:Auto Detector : Peak Project : 631725-02 Mode : 7</p>	 <p>Site : 03CH13-HY Condition : AVG_54 3m HORN_91200_1241 HORIZONTAL RBW:1000.000KHz VBW:1000KHz SWT:Auto Detector : Peak Project : 631725-02 Mode : 7</p>

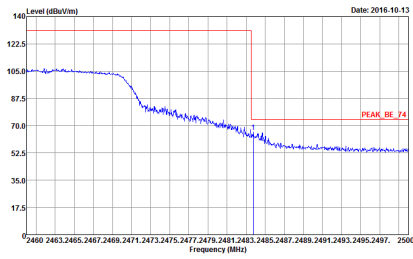
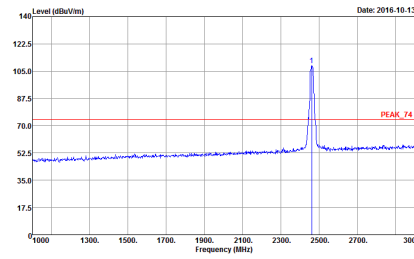
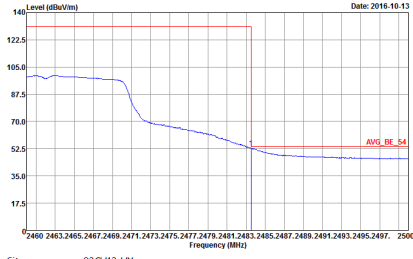
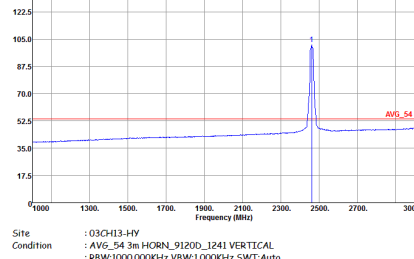

WIFI	2.4GHz 2400~2483.5MHz Band Edge @ 3m	
ANT	802.11g CH11 2462MHz	
1	Vertical	Fundamental
Peak	 <p>Site : 03CH13-HY Condition : PEAK_BE_74 3m HORN_9120D_1241 VERTICAL RBW:1000.000KHz VBW:3000.000KHz SWT:Auto Detector : Peak Project : 631725-02 Mode : 7</p>	 <p>Site : 03CH13-HY Condition : PEAK_74 3m HORN_9120D_1241 VERTICAL RBW:1000.000KHz VBW:3000.000KHz SWT:Auto Detector : Peak Project : 631725-02 Mode : 7</p>
Avg.	 <p>Site : 03CH13-HY Condition : AVG_BE_54 3m HORN_9120D_1241 VERTICAL RBW:1000.000KHz VBW:1.000KHz SWT:Auto Detector : Peak Project : 631725-02 Mode : 7</p>	 <p>Site : 03CH13-HY Condition : AVG_54 3m HORN_9120D_1241 VERTICAL RBW:1000.000KHz VBW:1.000KHz SWT:Auto Detector : Peak Project : 631725-02 Mode : 7</p>



2.4GHz 2400~2483.5MHz

WIFI 802.11n HT20 (Band Edge @ 3m)

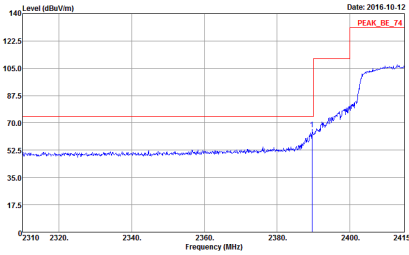
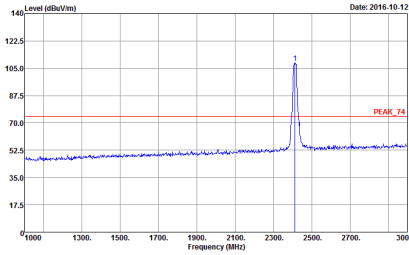
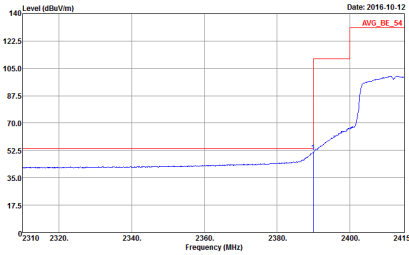
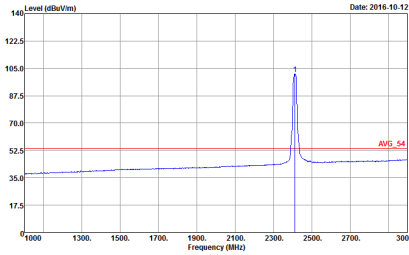
WIFI	2.4GHz 2400~2483.5MHz Band Edge @ 3m	
ANT	802.11n HT20 CH01 2412MHz	
1	Horizontal	Fundamental
Peak	 <p>Date: 2016-10-12 PEAK_BE_74</p> <p>Site : 03CH13-HY Condition : PEAK_BE_74 3m HORN_9120D_1241 HORIZONTAL : RBW:1000.000KHz VBW:3000.000KHz SWT:Auto Detector : Peak Project : 631725-02 Mode : 4</p>	 <p>Date: 2016-10-12 PEAK_74</p> <p>Site : 03CH13-HY Condition : PEAK_74 3m HORN_9120D_1241 HORIZONTAL : RBW:1000.000KHz VBW:3000.000KHz SWT:Auto Detector : Peak Project : 631725-02 Mode : 4</p>
Avg.	 <p>Date: 2016-10-12 AVG_BE_54</p> <p>Site : 03CH13-HY Condition : AVG_BE_54 3m HORN_9120D_1241 HORIZONTAL : RBW:1000.000KHz VBW:1000KHz SWT:Auto Detector : Peak Project : 631725-02 Mode : 4</p>	 <p>Date: 2016-10-12 AVG_54</p> <p>Site : 03CH13-HY Condition : AVG_54 3m HORN_9120D_1241 HORIZONTAL : RBW:1000.000KHz VBW:1000KHz SWT:Auto Detector : Peak Project : 631725-02 Mode : 4</p>

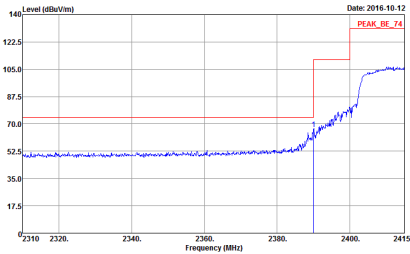
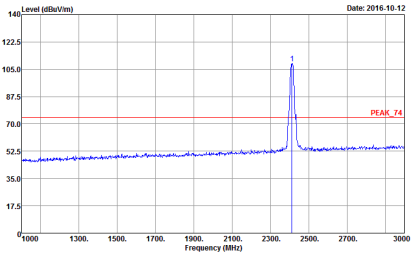
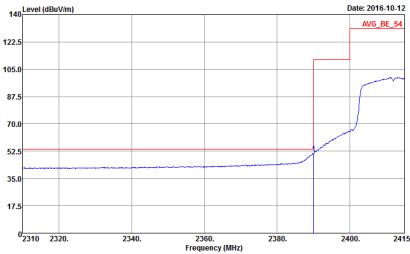
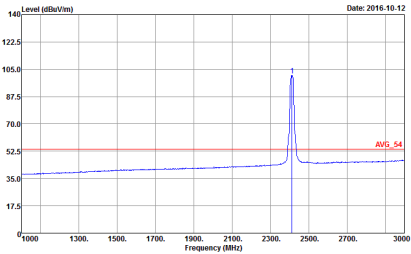

WIFI	2.4GHz 2400~2483.5MHz Band Edge @ 3m	
ANT	802.11n HT20 CH01 2412MHz	
1	Vertical	Fundamental
Peak	 <p>Date: 2016-10-12 PEAK_BE_74</p> <p>Site : 03CH13-HY Condition : PEAK_BE_74 3m HORN_9120D_1241 VERTICAL RBW:1000.000KHz VBW:3000.000KHz SWT:Auto Detector : Peak Project : 631725-02 Mode : 4</p>	 <p>Date: 2016-10-12 PEAK_74</p> <p>Site : 03CH13-HY Condition : PEAK_74 3m HORN_9120D_1241 VERTICAL RBW:1000.000KHz VBW:3000.000KHz SWT:Auto Detector : Peak Project : 631725-02 Mode : 4</p>
Avg.	 <p>Date: 2016-10-12 AVG_BE_54</p> <p>Site : 03CH13-HY Condition : AVG_BE_54 3m HORN_9120D_1241 VERTICAL RBW:1000.000KHz VBW:1000KHz SWT:Auto Detector : Peak Project : 631725-02 Mode : 4</p>	 <p>Date: 2016-10-12 AVG_54</p> <p>Site : 03CH13-HY Condition : AVG_54 3m HORN_9120D_1241 VERTICAL RBW:1000.000KHz VBW:1000KHz SWT:Auto Detector : Peak Project : 631725-02 Mode : 4</p>

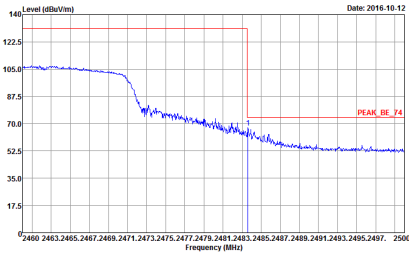
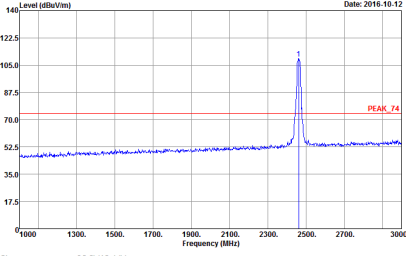
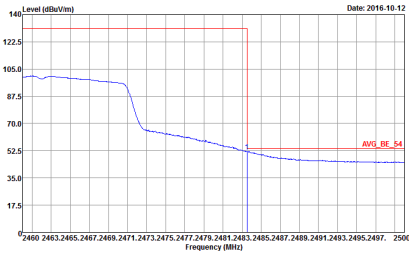
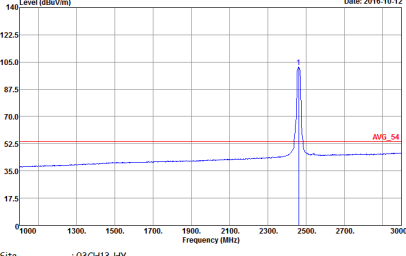

WIFI	2.4GHz 2400~2483.5MHz Band Edge @ 3m	
ANT	802.11n HT20 CH11 2462MHz	
1	Horizontal	Fundamental
Peak	 <p>Date: 2016-10-12</p> <p>Level (dBu/m)</p> <p>Frequency (MHz)</p> <p>Site : 03CH13-HY Condition : PEAK_BE_74 3m HORN_9120D_1241 HORIZONTAL : RBW:1000.000KHz VBW:3000.000KHz SWT:Auto Detector : Peak Project : 631725-02 Mode : 5</p>	 <p>Date: 2016-10-12</p> <p>Level (dBu/m)</p> <p>Frequency (MHz)</p> <p>Site : 03CH13-HY Condition : PEAK_74 3m HORN_9120D_1241 HORIZONTAL : RBW:1000.000KHz VBW:3000.000KHz SWT:Auto Detector : Peak Project : 631725-02 Mode : 5</p>
Avg.	 <p>Date: 2016-10-12</p> <p>Level (dBu/m)</p> <p>Frequency (MHz)</p> <p>Site : 03CH13-HY Condition : AVG_BE_54 3m HORN_9120D_1241 HORIZONTAL : RBW:1000.000KHz VBW:1000KHz SWT:Auto Detector : Peak Project : 631725-02 Mode : 5</p>	 <p>Date: 2016-10-12</p> <p>Level (dBu/m)</p> <p>Frequency (MHz)</p> <p>Site : 03CH13-HY Condition : AVG_54 3m HORN_9120D_1241 HORIZONTAL : RBW:1000.000KHz VBW:1000KHz SWT:Auto Detector : Peak Project : 631725-02 Mode : 5</p>

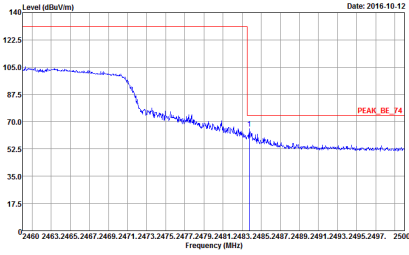
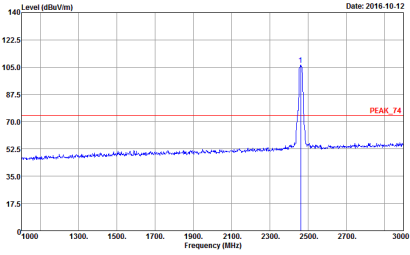
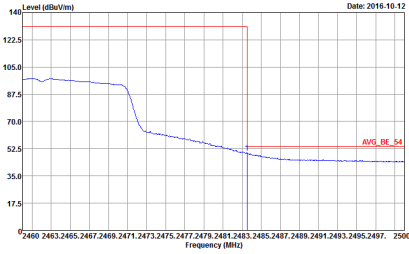
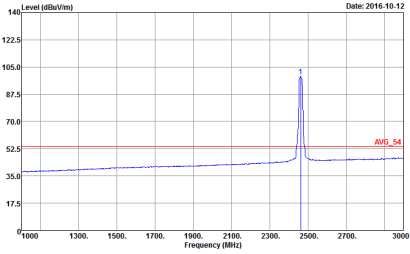

WIFI	2.4GHz 2400~2483.5MHz Fundamental @ 3m	
ANT	802.11n HT20 CH11 2462MHz	
1	Vertical	Fundamental
Peak	 <p>Date: 2016-10-12</p> <p>Site : 03CH13-HY Condition : PEAK_BE_74 3m HORN_9120D_1241 VERTICAL : RBW:1000.000KHz VBW:3000.000KHz SWT:Auto Detector : Peak Project : 631725-02 Mode : 5</p>	 <p>Date: 2016-10-12</p> <p>Site : 03CH13-HY Condition : PEAK_74 3m HORN_9120D_1241 VERTICAL : RBW:1000.000KHz VBW:3000.000KHz SWT:Auto Detector : Peak Project : 631725-02 Mode : 5</p>
Avg.	 <p>Date: 2016-10-12</p> <p>Site : 03CH13-HY Condition : AVG_BE_54 3m HORN_9120D_1241 VERTICAL : RBW:1000.000KHz VBW:1.000KHz SWT:Auto Detector : Peak Project : 631725-02 Mode : 5</p>	 <p>Date: 2016-10-12</p> <p>Site : 03CH13-HY Condition : AVG_54 3m HORN_9120D_1241 VERTICAL : RBW:1000.000KHz VBW:1.000KHz SWT:Auto Detector : Peak Project : 631725-02 Mode : 5</p>



2.4GHz 2400~2483.5MHz

WIFI 802.11b (Harmonic @ 3m)

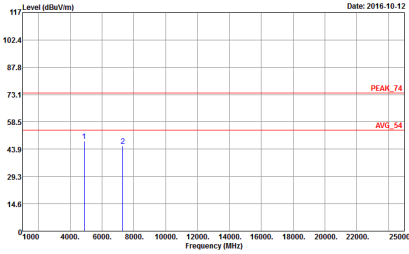
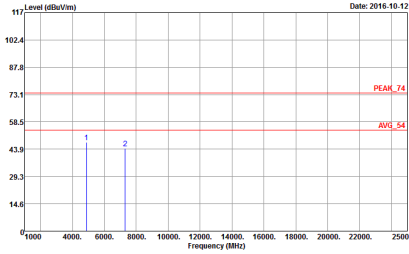
WIFI	2.4GHz 2400~2483.5MHz Harmonic @ 3m	
ANT	802.11b CH06 2437MHz	
1	Horizontal	Vertical
Peak Avg.	 <p>Site : 03CH13-HY Condition : PEAK_74 3m SHF_HORN_584 HORIZONTAL Detector : Peak Project : 631725-02 Mode : 3</p>	 <p>Site : 03CH13-HY Condition : PEAK_74 3m SHF_HORN_584 VERTICAL Detector : Peak Project : 631725-02 Mode : 3</p>



Emission below 1GHz
2.4GHz WIFI 802.11n HT20 (LF)

Table with 2 columns: Horizontal and Vertical. It contains two graphs showing Level (dBuV/m) vs Frequency (MHz) for a QP / Peak measurement. The graphs show a blue signal line and a red limit line. The horizontal graph is for 'Horizontal' and the vertical graph is for 'Vertical'. Both graphs show a peak at approximately 100 MHz.



<Ant. 2>

2.4GHz 2400~2483.5MHz

WIFI 802.11b (Band Edge @ 3m)

WIFI	2.4GHz 2400~2483.5MHz Band Edge @ 3m	
ANT	802.11b CH01 2412MHz	
2	Horizontal	Fundamental
Peak	<p>Site : 03CH13-HY Condition : PEAK_BE_74 3m HORN_9120D_1241 HORIZONTAL RBW:1000.000KHz VBW:3000.000KHz SWT:Auto Detector : Peak Project : 631725-02 Mode : 10 Power : 23</p>	<p>Site : 03CH13-HY Condition : PEAK_74 3m HORN_9120D_1241 HORIZONTAL RBW:1000.000KHz VBW:3000.000KHz SWT:Auto Detector : Peak Project : 631725-02 Mode : 10 Power : 23</p>
Avg.	<p>Site : 03CH13-HY Condition : AVG_BE_54 3m HORN_9120D_1241 HORIZONTAL RBW:1000.000KHz VBW:0.300KHz SWT:Auto Detector : Peak Project : 631725-02 Mode : 10 Power : 23</p>	<p>Site : 03CH13-HY Condition : AVG_54 3m HORN_9120D_1241 HORIZONTAL RBW:1000.000KHz VBW:0.300KHz SWT:Auto Detector : Peak Project : 631725-02 Mode : 10 Power : 23</p>

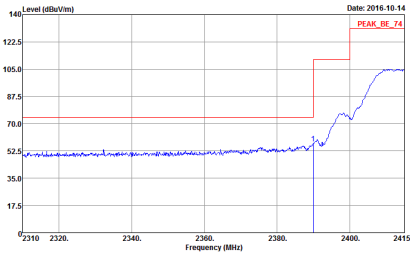
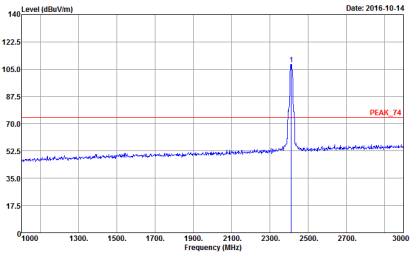
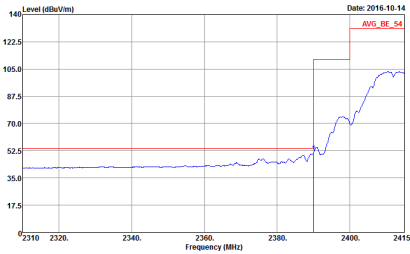
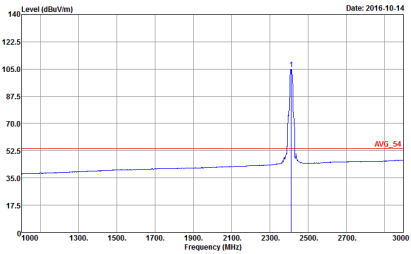

WIFI	2.4GHz 2400~2483.5MHz Band Edge @ 3m	
ANT	802.11b CH01 2412MHz	
2	Vertical	Fundamental
Peak	 <p>Date: 2016-10-14 PEAK_BE_74</p> <p>Site : 03CH13-HY Condition : PEAK_BE_74 3m HORN_91200_1241 VERTICAL RBW:1000.000KHz VBW:3000.000KHz SWT:Auto Detector : Peak Project : 631725-02 Mode : 10 Power : 23</p>	 <p>Date: 2016-10-14 PEAK_74</p> <p>Site : 03CH13-HY Condition : PEAK_74 3m HORN_91200_1241 VERTICAL RBW:1000.000KHz VBW:3000.000KHz SWT:Auto Detector : Peak Project : 631725-02 Mode : 10 Power : 23</p>
Avg.	 <p>Date: 2016-10-14 AVG_BE_54</p> <p>Site : 03CH13-HY Condition : AVG_BE_54 3m HORN_91200_1241 VERTICAL RBW:1000.000KHz VBW:0.300KHz SWT:Auto Detector : Peak Project : 631725-02 Mode : 10 Power : 23</p>	 <p>Date: 2016-10-14 AVG_54</p> <p>Site : 03CH13-HY Condition : AVG_54 3m HORN_91200_1241 VERTICAL RBW:1000.000KHz VBW:0.300KHz SWT:Auto Detector : Peak Project : 631725-02 Mode : 10 Power : 23</p>

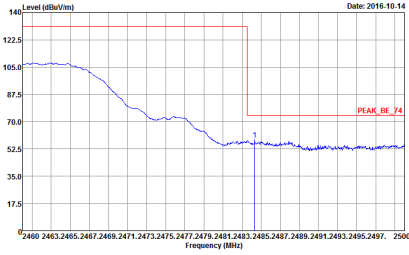
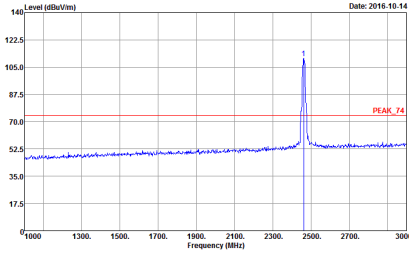
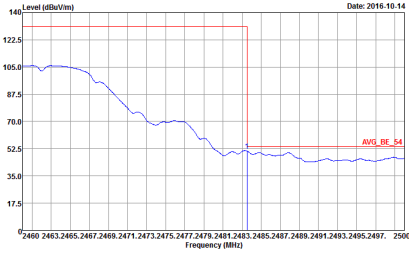
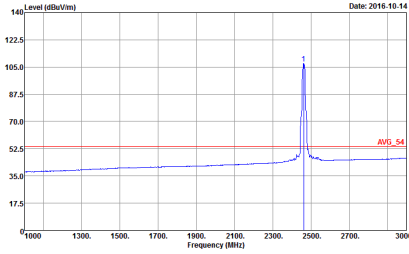

WIFI	2.4GHz 2400~2483.5MHz Band Edge @ 3m	
ANT	802.11b CH11 2462MHz	
2	Horizontal	Fundamental
Peak	 <p>Site : 03CH13-HY Condition : PEAK_BE_74 3m HORN_91200_1241 HORIZONTAL : RBW:1000.000KHz VBW:3000.000KHz SWT:Auto Detector : Peak Project : 631725-02 Mode : 12 Power : 22</p>	 <p>Site : 03CH13-HY Condition : PEAK_74 3m HORN_91200_1241 HORIZONTAL : RBW:1000.000KHz VBW:3000.000KHz SWT:Auto Detector : Peak Project : 631725-02 Mode : 12 Power : 22</p>
Avg.	 <p>Site : 03CH13-HY Condition : AVG_BE_54 3m HORN_91200_1241 HORIZONTAL : RBW:1000.000KHz VBW:0.300KHz SWT:Auto Detector : Peak Project : 631725-02 Mode : 12 Power : 22</p>	 <p>Site : 03CH13-HY Condition : AVG_54 3m HORN_91200_1241 HORIZONTAL : RBW:1000.000KHz VBW:0.300KHz SWT:Auto Detector : Peak Project : 631725-02 Mode : 12 Power : 22</p>

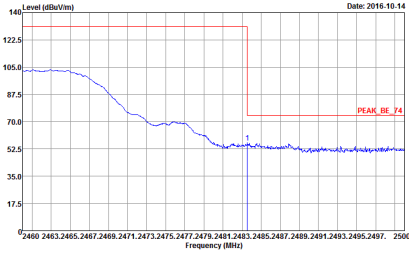
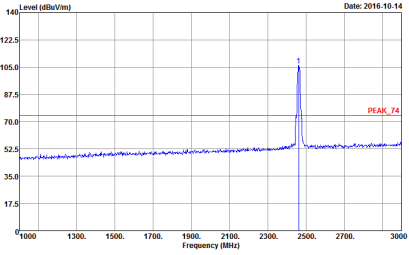
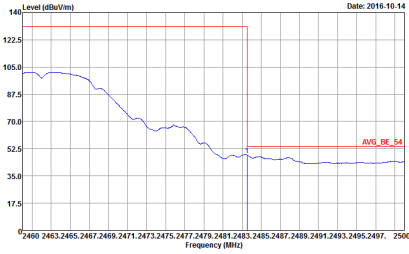
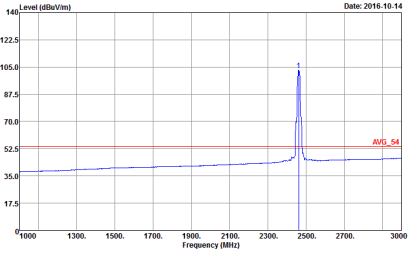

WIFI	2.4GHz 2400~2483.5MHz Band Edge @ 3m	
ANT	802.11b CH11 2462MHz	
2	Vertical	Fundamental
Peak	 <p>Site : 03CH13-HY Condition : PEAK_BE_74 3m HORN_91200_1241 VERTICAL : RBW:1000.000KHz VBW:3000.000KHz SWT:Auto Detector : Peak Project : 631725-02 Mode : 12 Power : 22</p>	 <p>Site : 03CH13-HY Condition : PEAK_74 3m HORN_91200_1241 VERTICAL : RBW:1000.000KHz VBW:3000.000KHz SWT:Auto Detector : Peak Project : 631725-02 Mode : 12 Power : 22</p>
Avg.	 <p>Site : 03CH13-HY Condition : AVG_BE_54 3m HORN_91200_1241 VERTICAL : RBW:1000.000KHz VBW:0.300KHz SWT:Auto Detector : Peak Project : 631725-02 Mode : 12 Power : 22</p>	 <p>Site : 03CH13-HY Condition : AVG_54 3m HORN_91200_1241 VERTICAL : RBW:1000.000KHz VBW:0.300KHz SWT:Auto Detector : Peak Project : 631725-02 Mode : 12 Power : 22</p>



2.4GHz 2400~2483.5MHz

WIFI 802.11g (Band Edge @ 3m)

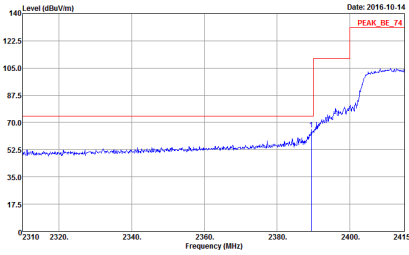
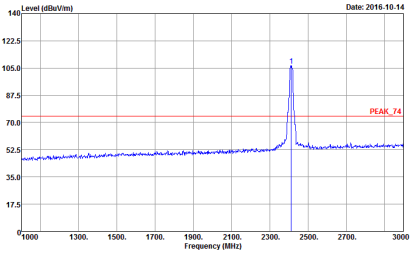
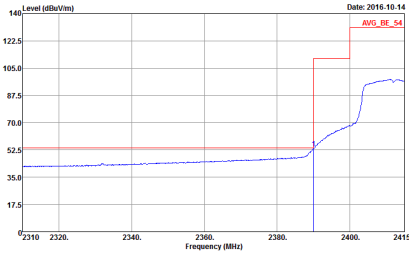
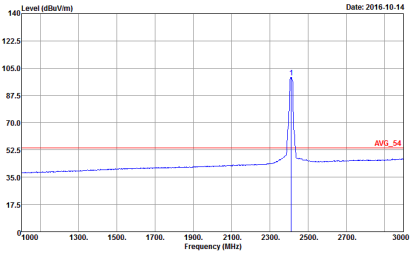
WIFI	2.4GHz 2400~2483.5MHz Band Edge @ 3m	
ANT	802.11g CH01 2412MHz	
2	Horizontal	Fundamental
Peak	 <p>Site : 03CH13-HY Condition : PEAK_BE_74 3m HORN_9120D_1241 HORIZONTAL : RBW:1000.000KHz VBW:3000.000KHz SWT:Auto Detector : Peak Project : 631725-02 Mode : 13</p>	 <p>Site : 03CH13-HY Condition : PEAK_74 3m HORN_9120D_1241 HORIZONTAL : RBW:1000.000KHz VBW:3000.000KHz SWT:Auto Detector : Peak Project : 631725-02 Mode : 13</p>
Avg.	 <p>Site : 03CH13-HY Condition : AVG_BE_54 3m HORN_9120D_1241 HORIZONTAL : RBW:1000.000KHz VBW:1.000KHz SWT:Auto Detector : Peak Project : 631725-02 Mode : 13</p>	 <p>Site : 03CH13-HY Condition : AVG_54 3m HORN_9120D_1241 HORIZONTAL : RBW:1000.000KHz VBW:1.000KHz SWT:Auto Detector : Peak Project : 631725-02 Mode : 13</p>

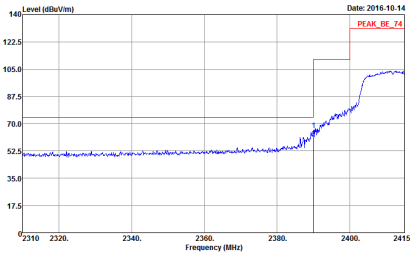
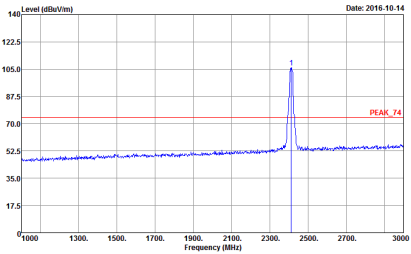
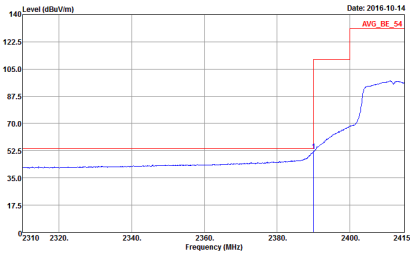
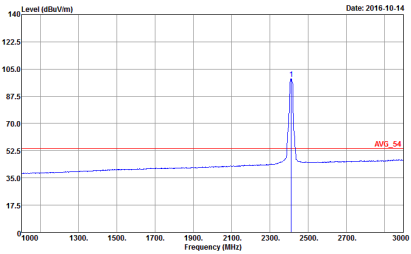

WIFI	2.4GHz 2400~2483.5MHz Band Edge @ 3m	
ANT	802.11g CH01 2412MHz	
2	Vertical	Fundamental
Peak	 <p>Date: 2016-10-14 PEAK_BE_74</p> <p>Site : 03CH13-HY Condition : PEAK_BE_74 3m HORN_9120D_1241 VERTICAL RBW:1000.000KHz VBW:3000.000KHz SWT:Auto Detector : Peak Project : 631725-02 Mode : 13</p>	 <p>Date: 2016-10-14 PEAK_74</p> <p>Site : 03CH13-HY Condition : PEAK_74 3m HORN_9120D_1241 VERTICAL RBW:1000.000KHz VBW:3000.000KHz SWT:Auto Detector : Peak Project : 631725-02 Mode : 13</p>
Avg.	 <p>Date: 2016-10-14 AVG_BE_54</p> <p>Site : 03CH13-HY Condition : AVG_BE_54 3m HORN_9120D_1241 VERTICAL RBW:1000.000KHz VBW:1.000KHz SWT:Auto Detector : Peak Project : 631725-02 Mode : 13</p>	 <p>Date: 2016-10-14 AVG_54</p> <p>Site : 03CH13-HY Condition : AVG_54 3m HORN_9120D_1241 VERTICAL RBW:1000.000KHz VBW:1.000KHz SWT:Auto Detector : Peak Project : 631725-02 Mode : 13</p>

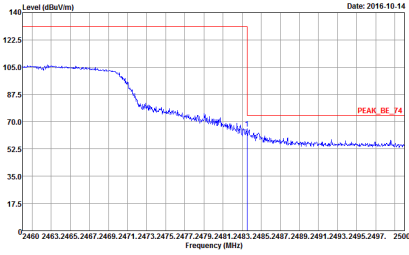
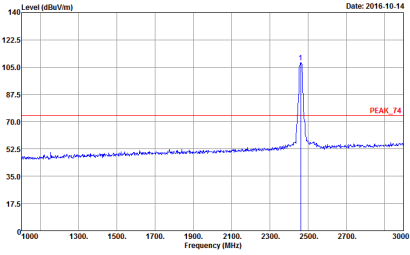
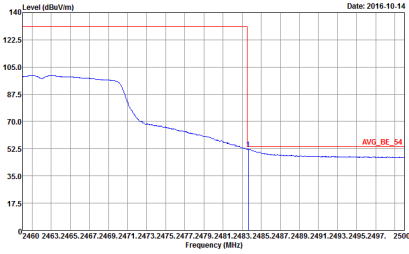
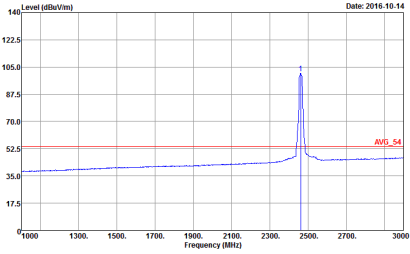

WIFI	2.4GHz 2400~2483.5MHz Band Edge @ 3m	
ANT	802.11g CH11 2462MHz	
2	Horizontal	Fundamental
Peak	 <p>Site : 03CH13-HY Condition : PEAK_BE_74 3m HORN_91200_1241 HORIZONTAL : RBW:1000.000KHz VBW:3000.000KHz SWT:Auto Detector : Peak Project : 631725-02 Mode : 14 : 18</p>	 <p>Site : 03CH13-HY Condition : PEAK_74 3m HORN_91200_1241 HORIZONTAL : RBW:1000.000KHz VBW:3000.000KHz SWT:Auto Detector : Peak Project : 631725-02 Mode : 14 : 18</p>
Avg.	 <p>Site : 03CH13-HY Condition : AVG_BE_54 3m HORN_91200_1241 HORIZONTAL : RBW:1000.000KHz VBW:1000KHz SWT:Auto Detector : Peak Project : 631725-02 Mode : 14 : 18</p>	 <p>Site : 03CH13-HY Condition : AVG_54 3m HORN_91200_1241 HORIZONTAL : RBW:1000.000KHz VBW:1000KHz SWT:Auto Detector : Peak Project : 631725-02 Mode : 14 : 18</p>

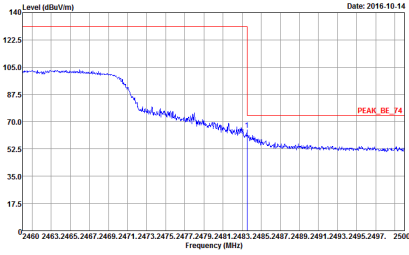
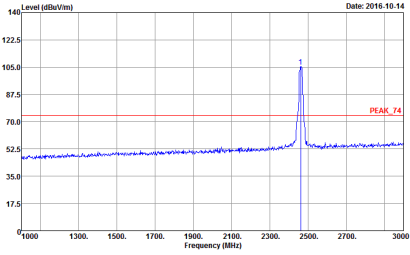
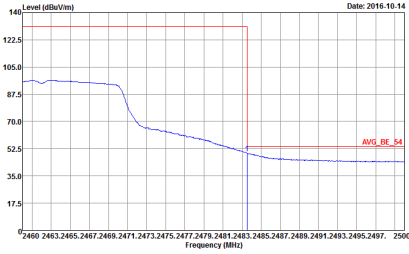
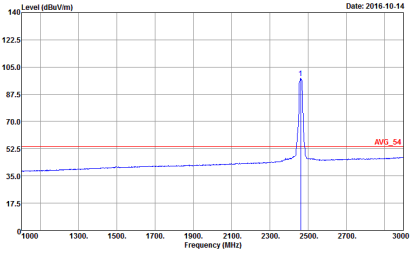

WIFI	2.4GHz 2400~2483.5MHz Band Edge @ 3m	
ANT	802.11g CH11 2462MHz	
2	Vertical	Fundamental
Peak	 <p>Level (dBu/m) vs Frequency (MHz) plot showing a peak at 2462 MHz. The y-axis ranges from 0 to 140 dBu/m, and the x-axis ranges from 2460 to 2500 MHz. A red box highlights the peak area. A red line indicates the peak level at approximately 105 dBu/m.</p> <p>Site : 03CH13-HY Condition : PEAK_BE_74 3m HORN_91200_1241 VERTICAL : RBW:1000.000KHz VBW:3000.000KHz SWT:Auto Detector : Peak Project : 631725-02 Mode : 14 : 18</p>	 <p>Level (dBu/m) vs Frequency (MHz) plot showing a sharp peak at 2462 MHz. The y-axis ranges from 0 to 140 dBu/m, and the x-axis ranges from 1000 to 3000 MHz. A red box highlights the peak area. A red line indicates the peak level at approximately 105 dBu/m.</p> <p>Site : 03CH13-HY Condition : PEAK_74 3m HORN_91200_1241 VERTICAL : RBW:1000.000KHz VBW:3000.000KHz SWT:Auto Detector : Peak Project : 631725-02 Mode : 14 : 18</p>
Avg.	 <p>Level (dBu/m) vs Frequency (MHz) plot showing the average level across the band. The y-axis ranges from 0 to 140 dBu/m, and the x-axis ranges from 2460 to 2500 MHz. A red box highlights the average level at approximately 55 dBu/m.</p> <p>Site : 03CH13-HY Condition : AVG_BE_54 3m HORN_91200_1241 VERTICAL : RBW:1000.000KHz VBW:1.000KHz SWT:Auto Detector : Peak Project : 631725-02 Mode : 14 : 18</p>	 <p>Level (dBu/m) vs Frequency (MHz) plot showing the average level across the band. The y-axis ranges from 0 to 140 dBu/m, and the x-axis ranges from 1000 to 3000 MHz. A red box highlights the average level at approximately 55 dBu/m.</p> <p>Site : 03CH13-HY Condition : AVG_54 3m HORN_91200_1241 VERTICAL : RBW:1000.000KHz VBW:1.000KHz SWT:Auto Detector : Peak Project : 631725-02 Mode : 14 : 18</p>



2.4GHz 2400~2483.5MHz

WIFI 802.11n HT20 (Band Edge @ 3m)

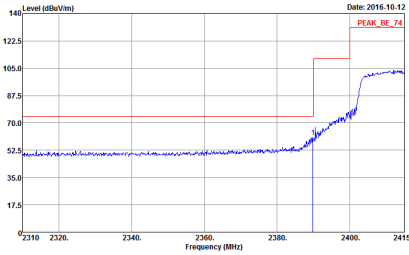
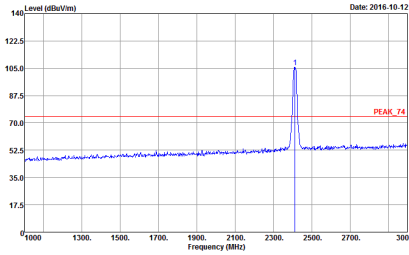
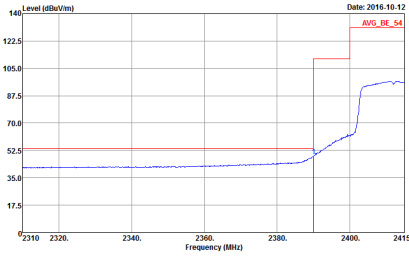
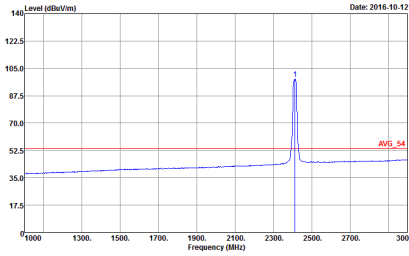
WIFI	2.4GHz 2400~2483.5MHz Band Edge @ 3m	
ANT	802.11n HT20 CH01 2412MHz	
2	Horizontal	Fundamental
Peak	 <p>Site : 03CH13-HY Condition : PEAK_BE_74 3m HORN_9120D_1241 HORIZONTAL RBW:1000.000KHz VBW:3000.000KHz SWT:Auto Detector : Peak Project : 631725-02 Mode : 7</p>	 <p>Site : 03CH13-HY Condition : PEAK_74 3m HORN_9120D_1241 HORIZONTAL RBW:1000.000KHz VBW:3000.000KHz SWT:Auto Detector : Peak Project : 631725-02 Mode : 7</p>
Avg.	 <p>Site : 03CH13-HY Condition : AVG_BE_54 3m HORN_9120D_1241 HORIZONTAL RBW:1000.000KHz VBW:1000KHz SWT:Auto Detector : Peak Project : 631725-02 Mode : 7</p>	 <p>Site : 03CH13-HY Condition : AVG_54 3m HORN_9120D_1241 HORIZONTAL RBW:1000.000KHz VBW:1000KHz SWT:Auto Detector : Peak Project : 631725-02 Mode : 7</p>

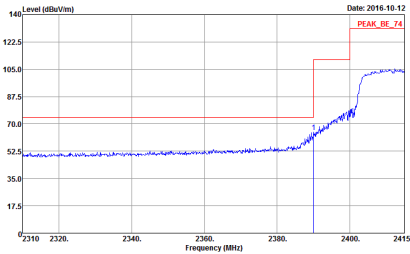
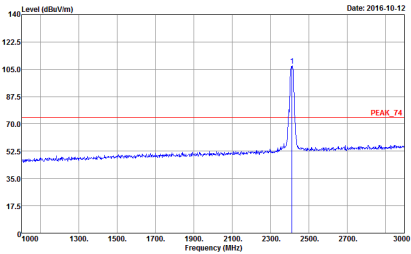
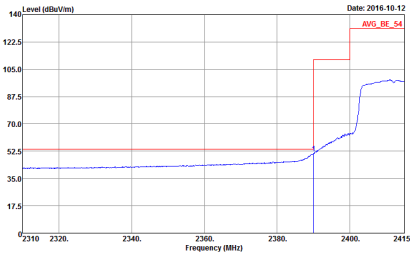
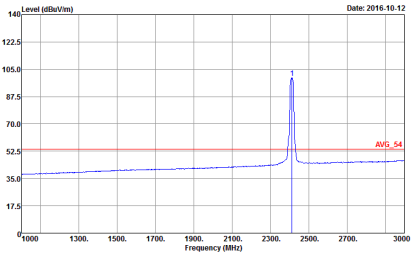

WIFI	2.4GHz 2400~2483.5MHz Band Edge @ 3m	
ANT	802.11n HT20 CH01 2412MHz	
2	Vertical	Fundamental
Peak	 <p>Date: 2016-10-12 PEAK_BE_74</p> <p>Site : 03CH13-HY Condition : PEAK_BE_74 3m HORN_9120D_1241 VERTICAL : RBW:1000.000KHz VBW:3000.000KHz SWT:Auto Detector : Peak Project : 631725-02 Mode : 7</p>	 <p>Date: 2016-10-12 PEAK_74</p> <p>Site : 03CH13-HY Condition : PEAK_74 3m HORN_9120D_1241 VERTICAL : RBW:1000.000KHz VBW:3000.000KHz SWT:Auto Detector : Peak Project : 631725-02 Mode : 7</p>
Avg.	 <p>Date: 2016-10-12 AVG_BE_54</p> <p>Site : 03CH13-HY Condition : AVG_BE_54 3m HORN_9120D_1241 VERTICAL : RBW:1000.000KHz VBW:1000KHz SWT:Auto Detector : Peak Project : 631725-02 Mode : 7</p>	 <p>Date: 2016-10-12 AVG_54</p> <p>Site : 03CH13-HY Condition : AVG_54 3m HORN_9120D_1241 VERTICAL : RBW:1000.000KHz VBW:1000KHz SWT:Auto Detector : Peak Project : 631725-02 Mode : 7</p>

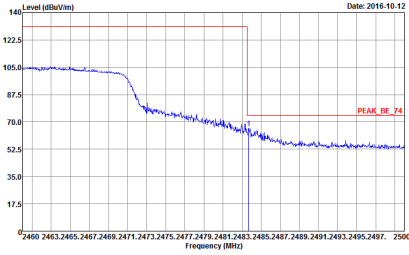
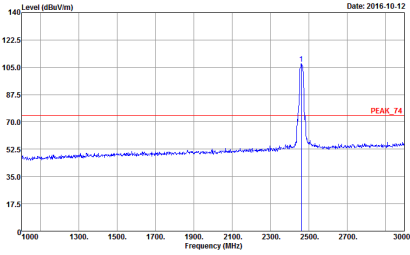
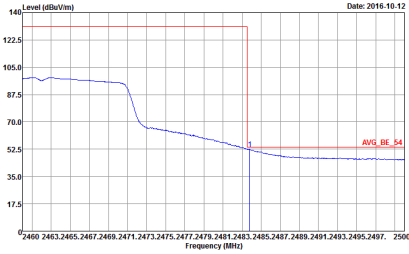
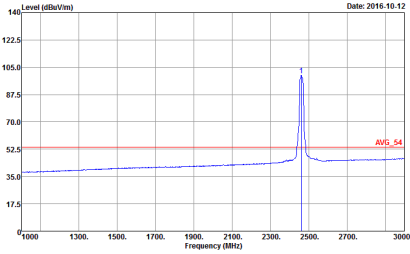

WIFI	2.4GHz 2400~2483.5MHz Band Edge @ 3m	
ANT	802.11n HT20 CH11 2462MHz	
2	Horizontal	Fundamental
Peak	 <p>Date: 2016-10-12</p> <p>Site : 03CH13-HY Condition : PEAK_BE_74 3m HORN_9120D_1241 HORIZONTAL : RBW:1000.000KHz VBW:3000.000KHz SWT:Auto Detector : Peak Project : 631725-02 Mode : 8</p>	 <p>Date: 2016-10-12</p> <p>Site : 03CH13-HY Condition : PEAK_74 3m HORN_9120D_1241 HORIZONTAL : RBW:1000.000KHz VBW:3000.000KHz SWT:Auto Detector : Peak Project : 631725-02 Mode : 8</p>
Avg.	 <p>Date: 2016-10-12</p> <p>Site : 03CH13-HY Condition : AVG_BE_54 3m HORN_9120D_1241 HORIZONTAL : RBW:1000.000KHz VBW:1000KHz SWT:Auto Detector : Peak Project : 631725-02 Mode : 8</p>	 <p>Date: 2016-10-12</p> <p>Site : 03CH13-HY Condition : AVG_54 3m HORN_9120D_1241 HORIZONTAL : RBW:1000.000KHz VBW:1000KHz SWT:Auto Detector : Peak Project : 631725-02 Mode : 8</p>

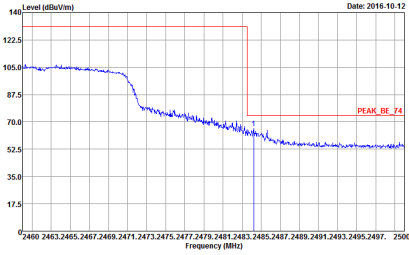
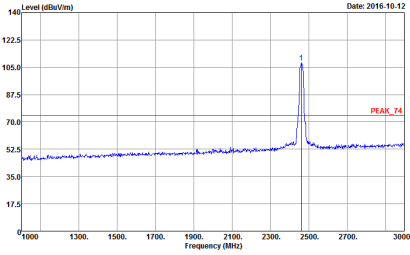
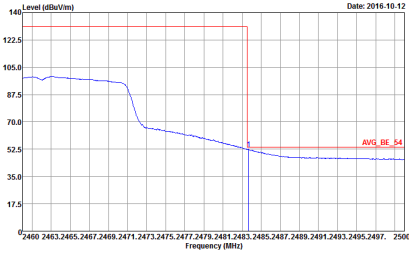
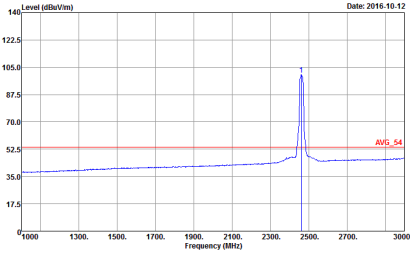

WIFI	2.4GHz 2400~2483.5MHz Fundamental @ 3m	
ANT	802.11n HT20 CH11 2462MHz	
2	Vertical	Fundamental
Peak	 <p>Level (dBu/m) vs Frequency (MHz) plot showing a peak at 2462 MHz. The y-axis ranges from 17.5 to 140 dBu/m, and the x-axis ranges from 2460 to 2500 MHz. A red box highlights the peak area.</p> <p>Site : 03CH13-HY Condition : PEAK_BE_74 3m HORN_9120D_1241 VERTICAL RBW:1000.000KHz VBW:3000.000KHz SWT:Auto Detector : Peak Project : 631725-02 Mode : 8</p>	 <p>Level (dBu/m) vs Frequency (MHz) plot showing a sharp peak at 2462 MHz. The y-axis ranges from 17.5 to 140 dBu/m, and the x-axis ranges from 1000 to 3000 MHz. A red box highlights the peak area.</p> <p>Site : 03CH13-HY Condition : PEAK_74 3m HORN_9120D_1241 VERTICAL RBW:1000.000KHz VBW:3000.000KHz SWT:Auto Detector : Peak Project : 631725-02 Mode : 8</p>
Avg.	 <p>Level (dBu/m) vs Frequency (MHz) plot showing the average level. The y-axis ranges from 17.5 to 140 dBu/m, and the x-axis ranges from 2460 to 2500 MHz. A red box highlights the average level area.</p> <p>Site : 03CH13-HY Condition : AVG_BE_54 3m HORN_9120D_1241 VERTICAL RBW:1000.000KHz VBW:1000KHz SWT:Auto Detector : Peak Project : 631725-02 Mode : 8</p>	 <p>Level (dBu/m) vs Frequency (MHz) plot showing the average level. The y-axis ranges from 17.5 to 140 dBu/m, and the x-axis ranges from 1000 to 3000 MHz. A red box highlights the average level area.</p> <p>Site : 03CH13-HY Condition : AVG_54 3m HORN_9120D_1241 VERTICAL RBW:1000.000KHz VBW:1000KHz SWT:Auto Detector : Peak Project : 631725-02 Mode : 8</p>



2.4GHz 2400~2483.5MHz
WIFI 802.11b (Harmonic @ 3m)

WIFI	2.4GHz 2400~2483.5MHz Harmonic @ 3m	
ANT	802.11b CH06 2437MHz	
2	Horizontal	Vertical
Peak Avg.	<p>Site : 03CH13-HY Condition : PEAK_74 3m SHF_HORN_584 HORIZONTAL Detector : Peak Project : 631725-02 Mode : 6</p>	<p>Site : 03CH13-HY Condition : PEAK_74 3m SHF_HORN_584 VERTICAL Detector : Peak Project : 631725-02 Mode : 6</p>



Emission below 1GHz
2.4GHz WIFI 802.11n HT20 (LF)

Table with 2 columns: Horizontal and Vertical. It contains two graphs showing Level (dBuV/m) vs Frequency (MHz) for a QP / Peak. The graphs show a blue signal line and a red QP line. Metadata includes Site: 03CH13-HY, Condition: QP 3m BILOG_40103 HORIZONTAL, Detector: Peak, Project: 631725-02, Mode: 12.

Appendix D. Duty Cycle Plots

Antenna	Band	Duty Cycle(%)	T(us)	1/T(kHz)	VBW Setting
1	802.11b	97.66	8360	0.12	300Hz
1	802.11g	88.46	1380	0.72	1kHz
1	2.4GHz 802.11n HT20	87.84	1300	0.77	1kHz
2	802.11b	97.66	8360	0.12	300Hz
2	802.11g	87.34	1380	0.72	1kHz
2	2.4GHz 802.11n HT20	87.84	1300	0.77	1kHz

<Ant. 1>

802.11b

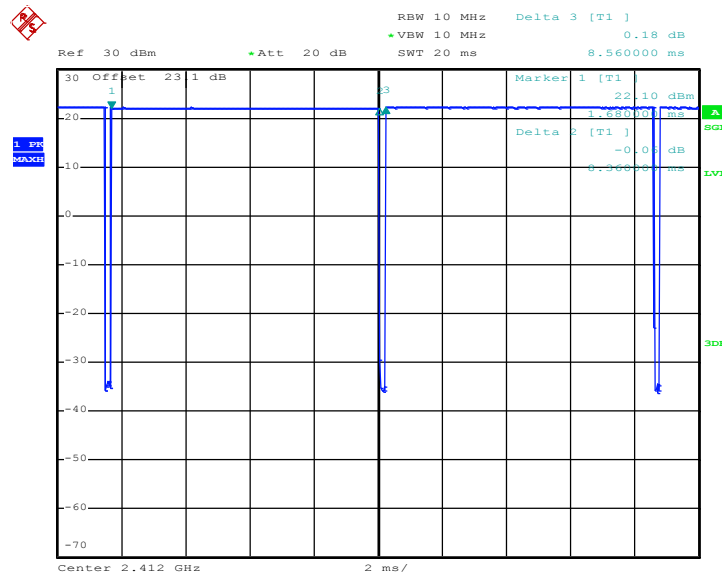

Date: 3.OCT.2016 20:16:06



802.11g

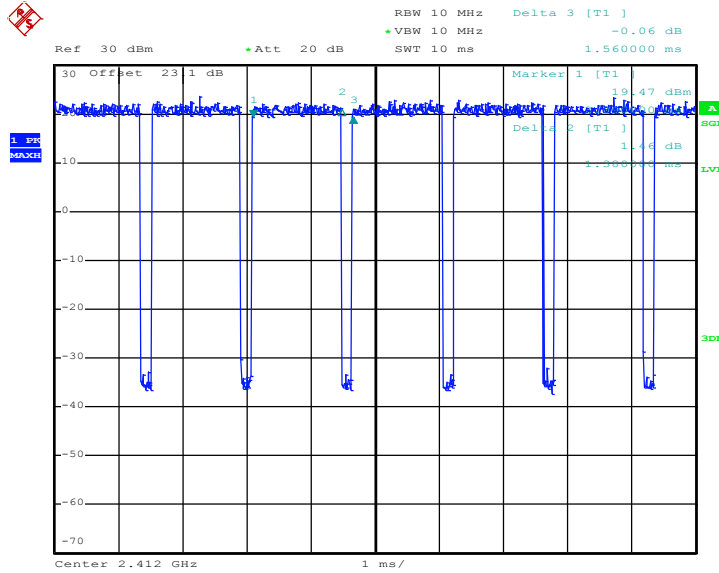

Date: 3.OCT.2016 20:24:33

802.11n HT20

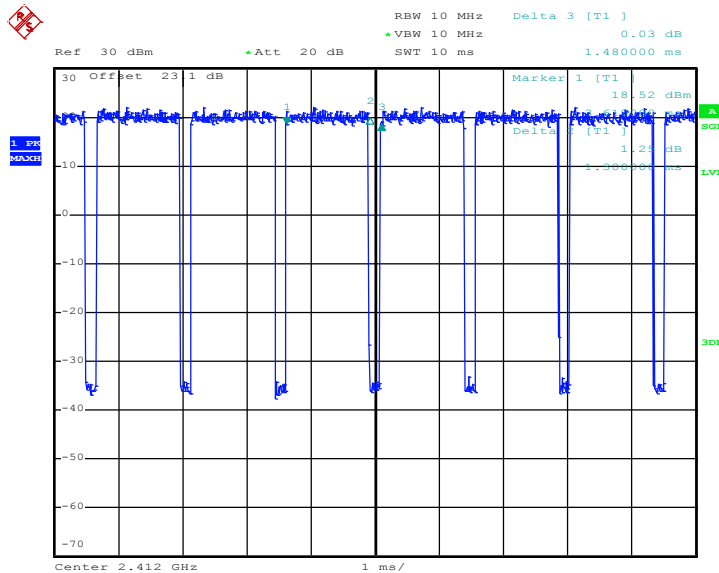

Date: 3.OCT.2016 20:34:13



<Ant. 2>

802.11b

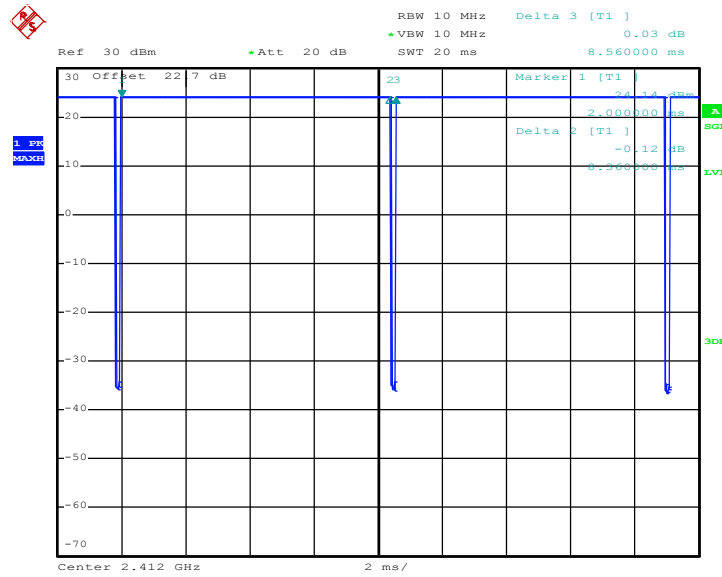

Date: 3.OCT.2016 20:42:30

802.11g

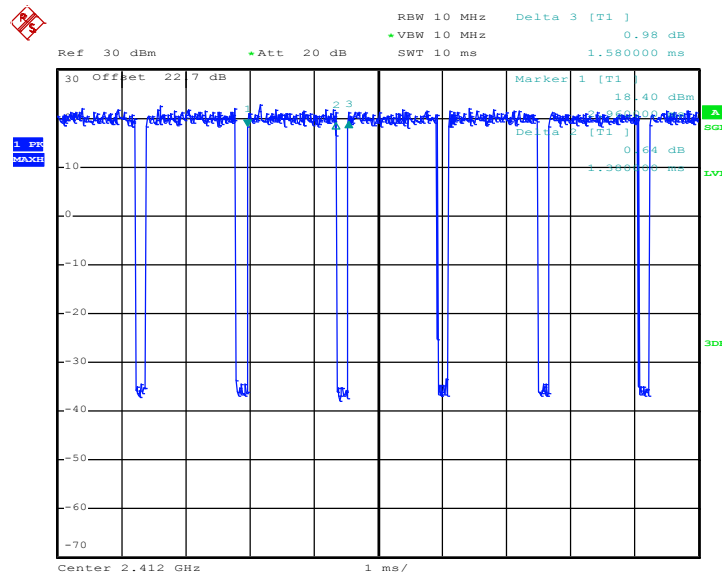

Date: 3.OCT.2016 21:09:18



802.11n HT20

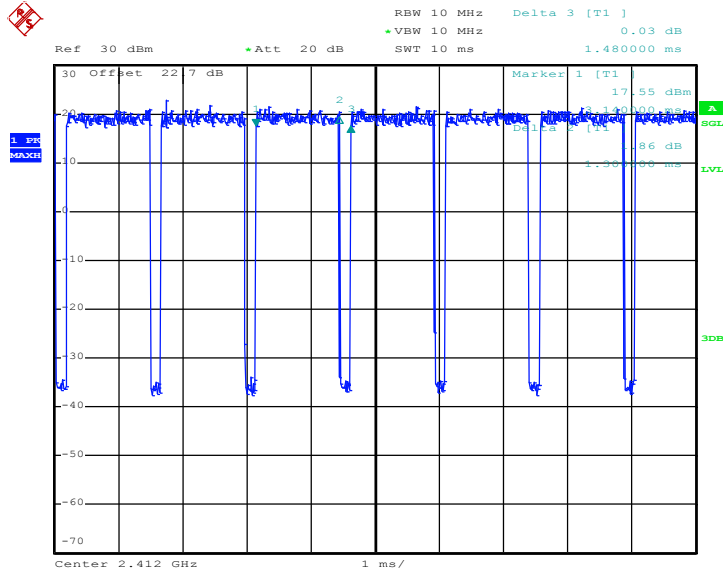

Date: 3.OCT.2016 21:15:38