



FCC RF Test Report

APPLICANT : Altocumulous LLC
EQUIPMENT : Digital Media Receiver
MODEL NAME : RS03QR
FCC ID : 2AHSE-2045
STANDARD : FCC Part 15 Subpart C §15.247
CLASSIFICATION : (DTS) Digital Transmission System

The testing was completed on Jun. 29, 2016. We, SPORTON INTERNATIONAL INC., would like to declare that the tested sample has been evaluated in accordance with the test procedures and has been in compliance with the applicable technical standards.

The test results in this report apply exclusively to the tested model / sample. Without written approval of SPORTON INTERNATIONAL INC., the test report shall not be reproduced except in full.

Reviewed by: Joseph Lin / Supervisor

Approved by: Jones Tsai / Manager



SPORTON INTERNATIONAL INC.

No. 52, Hwa Ya 1st Rd., Hwa Ya Technology Park, Kwei-Shan District, Tao Yuan City, Taiwan, R.O.C.



TABLE OF CONTENTS

REVISION HISTORY..... 3

SUMMARY OF TEST RESULT 4

1 GENERAL DESCRIPTION 5

 1.1 Applicant 5

 1.2 Product Feature of Equipment Under Test..... 5

 1.3 Product Specification of Equipment Under Test..... 5

 1.4 Modification of EUT 5

 1.5 Testing Location 6

 1.6 Applicable Standards..... 6

2 TEST CONFIGURATION OF EQUIPMENT UNDER TEST 7

 2.1 Carrier Frequency and Channel 7

 2.2 Pre-Scanned RF Power..... 8

 2.3 Test Mode..... 9

 2.4 Connection Diagram of Test System..... 10

 2.5 Support Unit used in test configuration and system 11

 2.6 EUT Operation Test Setup 11

 2.7 Measurement Results Explanation Example..... 11

3 TEST RESULT 12

 3.1 6dB and 99% Bandwidth Measurement 12

 3.2 Peak Output Power Measurement 14

 3.3 Power Spectral Density Measurement 15

 3.4 Conducted Band Edges and Spurious Emission Measurement 17

 3.5 Radiated Band Edges and Spurious Emission Measurement 36

 3.6 AC Conducted Emission Measurement..... 40

 3.7 Antenna Requirements..... 44

4 LIST OF MEASURING EQUIPMENT 45

5 UNCERTAINTY OF EVALUATION 46

APPENDIX A. CONDUCTED TEST RESULTS

APPENDIX B. RADIATED SPURIOUS EMISSION

APPENDIX C. RADIATED SPURIOUS EMISSION PLOTS

APPENDIX D. DUTY CYCLE PLOTS



REVISION HISTORY

REPORT NO.	VERSION	DESCRIPTION	ISSUED DATE
FR631725-01C	Rev. 01	Initial issue of report	Jul. 01, 2016
FR631725-01C	Rev. 02	Update report of revising AC Conducted Emission test data and RSE test data	Jul. 19, 2016



SUMMARY OF TEST RESULT

Report Section	FCC Rule	Description	Limit	Result
3.1	15.247(a)(2)	6dB Bandwidth	$\geq 0.5\text{MHz}$	Pass
3.1	-	99% Bandwidth	-	Pass
3.2	15.247(b)	Power Output Measurement	$\leq 30\text{dBm}$	Pass
3.3	15.247(e)	Power Spectral Density	$\leq 8\text{dBm}/3\text{kHz}$	Pass
3.4	15.247(d)	Conducted Band Edges	$\leq 20\text{dBc}$	Pass
		Conducted Spurious Emission		Pass
3.5	15.247(d)	Radiated Band Edges and Radiated Spurious Emission	15.209(a) & 15.247(d)	Pass
3.6	15.207	AC Conducted Emission	15.207(a)	Pass
3.7	15.203 & 15.247(b)	Antenna Requirement	N/A	Pass



1 General Description

1.1 Applicant

Altocumulous LLC

300 E. Business Way, Suite 200, Summit Woods Corporate Center Cincinnati, Ohio 45241

1.2 Product Feature of Equipment Under Test

Product Feature	
Equipment	Digital Media Receiver
Model Name	RS03QR
FCC ID	2AHSE-2045
EUT supports Radios application	WLAN 11b/g/n HT20 WLAN 11a/n HT20/HT40 Bluetooth v4.1 EDR/LE

1.3 Product Specification of Equipment Under Test

Standards-related Product Specification							
Tx/Rx Channel Frequency Range	2412 MHz ~ 2462 MHz						
Maximum (Peak) Output Power to antenna	<p><Ant. 1> 802.11b : 22.92 dBm (0.1959 W) 802.11g : 25.56 dBm (0.3597 W) 802.11n HT20 : 25.51 dBm (0.3556 W)</p> <p><Ant. 2> 802.11b : 24.01 dBm (0.2518 W) 802.11g : 25.24 dBm (0.3342 W) 802.11n HT20 : 25.26 dBm (0.3357 W)</p>						
99% Occupied Bandwidth	802.11b : 14.55MHz 802.11g : 18.60MHz 802.11n HT20 : 19.00MHz						
Antenna Type	<p><Ant. 1> : Fixed Internal type with gain 1.47 dBi <Ant. 2> : Fixed Internal type with gain 2.36 dBi</p>						
Type of Modulation	802.11b : DSSS (DBPSK / DQPSK / CCK) 802.11g/n : OFDM (BPSK / QPSK / 16QAM / 64QAM)						
Antenna Function for Transmitter	<table border="1"> <thead> <tr> <th></th> <th>Ant. 1</th> <th>Ant. 2</th> </tr> </thead> <tbody> <tr> <td>802.11 b/g/n</td> <td>V</td> <td>V</td> </tr> </tbody> </table>		Ant. 1	Ant. 2	802.11 b/g/n	V	V
	Ant. 1	Ant. 2					
802.11 b/g/n	V	V					

1.4 Modification of EUT

No modifications are made to the EUT during all test items.



1.5 Testing Location

Sporton Lab is accredited to ISO 17025 by Taiwan Accreditation Foundation (TAF code : 1190) and the FCC designation No. TW1022 under the FCC 2.948(e) by Mutual Recognition Agreement (MRA) in FCC Test.

Test Site	SPORTON INTERNATIONAL INC.	
Test Site Location	No. 52, Hwa Ya 1 st Rd., Hwa Ya Technology Park, Kwei-Shan District, Tao Yuan City, Taiwan, R.O.C. TEL: +886-3-327-3456 FAX: +886-3-328-4978	
Test Site No.	Sporton Site No.	
	TH02-HY	CO05-HY

Note: The test site complies with ANSI C63.4 2014 requirement.

Test Site	SPORTON INTERNATIONAL INC.	
Test Site Location	No.58, Aly. 75, Ln. 564, Wenhua 3rd Rd. Guishan Dist, Taoyuan City, Taiwan (R.O.C.) TEL: +886-3-327-0868 FAX: +886-3-327-0855	
Test Site No.	Sporton Site No.	
	03CH13-HY	

Note: The test site complies with ANSI C63.4 2014 requirement.

1.6 Applicable Standards

According to the specifications of the manufacturer, the EUT must comply with the requirements of the following standards:

- ♦ FCC Part 15 Subpart C §15.247
- ♦ FCC KDB Publication No. 558074 D01 DTS Meas. Guidance v03r05
- ♦ FCC KDB 662911 D01 Multiple Transmitter Output v02r01.
- ♦ ANSI C63.10-2013

Remark: All test items were verified and recorded according to the standards and without any deviation during the test.



2 Test Configuration of Equipment Under Test

The EUT has been associated with peripherals and configuration operated in a manner tended to maximize its emission characteristics in a typical application. Frequency range investigated: conducted emission (150 kHz to 30 MHz) and radiated emission (9 kHz to the 10th harmonic of the highest fundamental frequency or to 40 GHz, whichever is lower).

The final configuration from all the combinations and the worst-case data rates were investigated by measuring the maximum power across all the data rates and modulation modes under section 2.2.

Based on the worst configuration found above, the RF power setting is set individually to meet FCC compliance limit for the final conducted and radiated tests shown in section 2.3.

2.1 Carrier Frequency and Channel

Frequency Band	Channel	Freq. (MHz)	Channel	Freq. (MHz)
2400-2483.5 MHz	1	2412	7	2442
	2	2417	8	2447
	3	2422	9	2452
	4	2427	10	2457
	5	2432	11	2462
	6	2437		



2.2 Pre-Scanned RF Power

Preliminary tests were performed in different data rate and data rate associated with the highest power were chosen for full test shown in the following tables.

<Ant. 1>

802.11b				
Data Rate (MHz)	1M bps	2M bps	5.5M bps	11M bps
Peak Power (dBm)	22.92	22.64	22.57	20.69

802.11g								
Data Rate (MHz)	6M bps	9M bps	12M bps	18M bps	24M bps	36M bps	48M bps	54M bps
Peak Power (dBm)	25.56	25.36	25.27	25.23	25.34	25.23	25.30	25.31

2.4GHz 802.11n HT20								
Data Rate (MHz)	MCS0	MCS1	MCS2	MCS3	MCS4	MCS5	MCS6	MCS7
Peak Power (dBm)	25.51	25.32	25.24	25.25	25.17	25.37	25.46	25.26

<Ant. 2>

802.11b				
Data Rate (MHz)	1M bps	2M bps	5.5M bps	11M bps
Peak Power (dBm)	24.01	23.92	23.86	23.79

802.11g								
Data Rate (MHz)	6M bps	9M bps	12M bps	18M bps	24M bps	36M bps	48M bps	54M bps
Peak Power (dBm)	25.24	25.16	25.00	24.82	25.07	25.09	25.12	24.93

2.4GHz 802.11n HT20								
Data Rate (MHz)	MCS0	MCS1	MCS2	MCS3	MCS4	MCS5	MCS6	MCS7
Peak Power (dBm)	25.26	25.02	24.95	25.02	25.06	25.07	24.90	24.98



2.3 Test Mode

Final test mode of conducted test items and radiated spurious emissions are considering the modulation and worse data rates from the power table described in section 2.2.

Modulation	Data Rate
802.11b	1 Mbps
802.11g	6 Mbps
802.11n HT20	MCS0

Test Cases	
AC Conducted Emission	Mode 1 :WLAN (2.4GHz) Link + Bluetooth Link + MP3 + USB Cable (Charging from Adapter)

2.4 Connection Diagram of Test System

<WLAN Tx Mode>

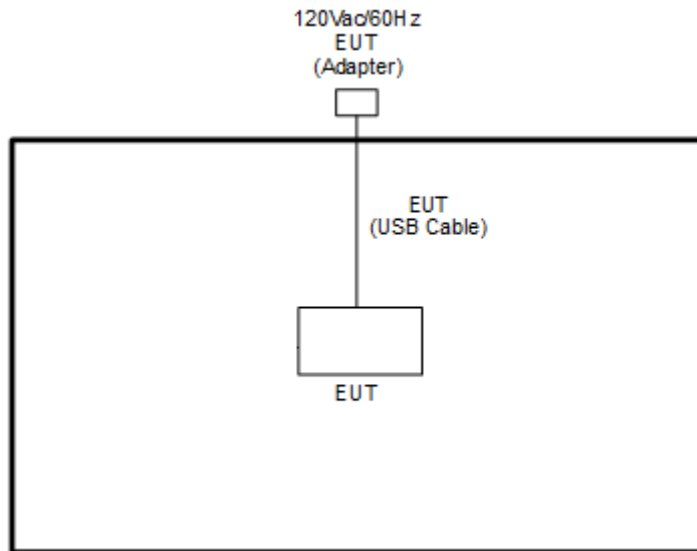

<AC Conducted Emission Mode>

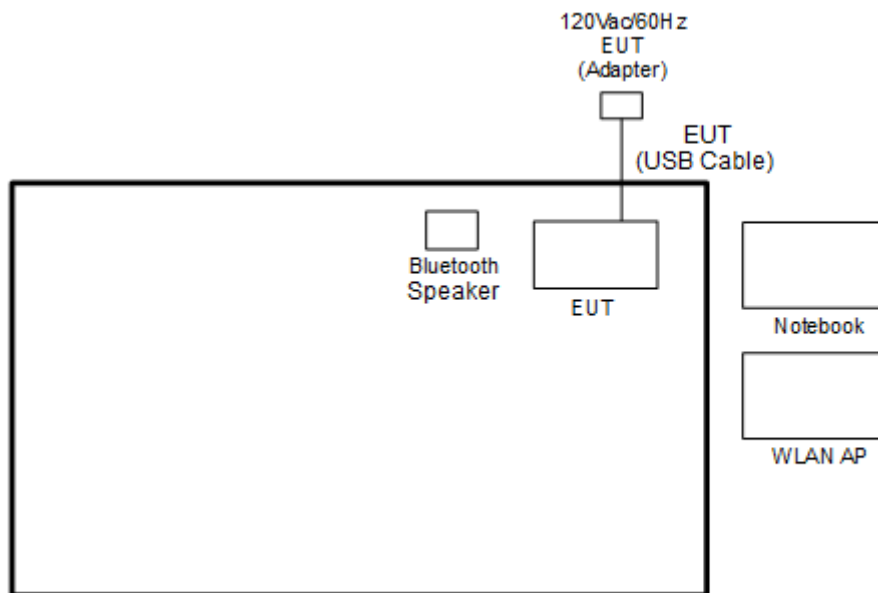



2.5 Support Unit used in test configuration and system

Item	Equipment	Trade Name	Model Name	FCC ID	Data Cable	Power Cord
1.	Bluetooth Speaker	JAWBONE	JAMBOX	V3J-JBE	N/A	N/A
2.	WLAN AP	D-Link	DIR-628	KA2DIR628A2	N/A	Unshielded, 1.8 m
3.	Notebook	DELL	Latitude E6320	FCC DoC/ Contains FCC ID: QDS-BRCM1054	N/A	AC I/P: Unshielded, 1.2 m DC O/P: Shielded, 1.8 m

2.6 EUT Operation Test Setup

For WLAN function, programmed RF utility, "Compliance.exe" installed in the notebook make the EUT provide functions like channel selection and power level for continuous transmitting and receiving signals.

2.7 Measurement Results Explanation Example

For all conducted test items:

The offset level is set in the spectrum analyzer to compensate the RF cable loss and attenuator factor between EUT conducted output port and spectrum analyzer. With the offset compensation, the spectrum analyzer reading level is exactly the EUT RF output level.

Example:

The spectrum analyzer offset is derived from RF cable loss and attenuator factor.

Offset = RF cable loss + attenuator factor.

Following shows an offset computation example with cable loss 4.2 dB and 10dB attenuator.

$$\begin{aligned}
 \text{Offset(dB)} &= \text{RF cable loss(dB)} + \text{attenuator factor(dB)}. \\
 &= 4.2 + 10 = 14.2 \text{ (dB)}
 \end{aligned}$$

3 Test Result

3.1 6dB and 99% Bandwidth Measurement

3.1.1 Limit of 6dB and 99% Bandwidth

The minimum 6 dB bandwidth shall be at least 500 kHz.

3.1.2 Measuring Instruments

The measuring equipment is listed in the section 4 of this test report.

3.1.3 Test Procedures

1. The testing follows FCC KDB Publication No. 558074 DTS D01 Meas. Guidance v03r05.
2. The RF output of EUT was connected to the spectrum analyzer by RF cable and attenuator. The path loss was compensated to the results for each measurement.
3. Set to the maximum power setting and enable the EUT transmit continuously.
4. Make the measurement with the spectrum analyzer's resolution bandwidth (RBW) = 100 kHz. Set the Video bandwidth (VBW) = 300 kHz. In order to make an accurate measurement. The 6 dB bandwidth must be greater than 500 kHz.
5. For 99% Bandwidth Measurement, the spectrum analyzer's resolution bandwidth (RBW) = 1MHz and set the Video bandwidth (VBW) = 3MHz.
6. Measure and record the results in the test report.

3.1.4 Test Setup





3.1.5 Test Result of 6dB and 99% Occupied Bandwidth

Please refer to Appendix A.

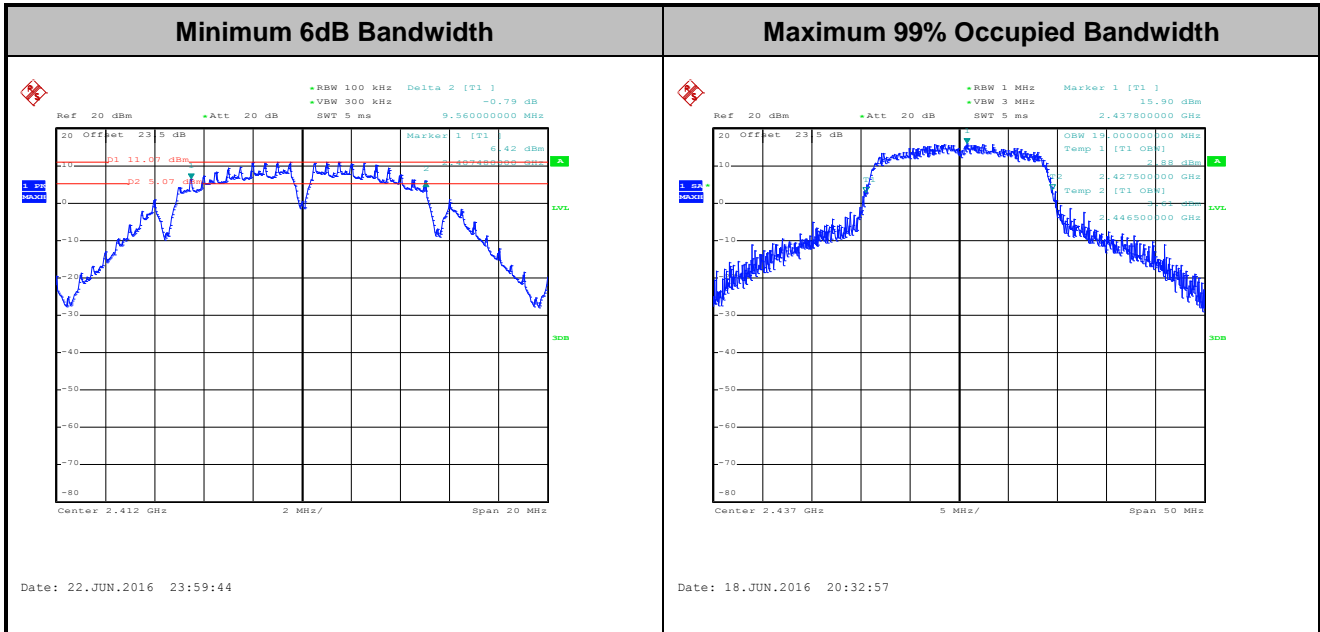

Note: The occupied channel bandwidth is maintained within the band of operation for all of the modulations.

3.2 Peak Output Power Measurement

3.2.1 Limit of Peak Output Power

For systems using digital modulation in the 2400-2483.5MHz, the limit for peak output power is 30dBm. If transmitting antenna with directional gain greater than 6dBi is used, the peak output power from the intentional radiator shall be reduced below the above stated value by the amount in dB that the directional gain of the antenna exceeds 6 dBi. In case of point-to-point operation, the limit has to be reduced by 1dB for every 3dB that the directional gain of the antenna exceeds 6dBi.

3.2.2 Measuring Instruments

The measuring equipment is listed in the section 4 of this test report.

3.2.3 Test Procedures

1. The testing follows the Measurement Procedure of FCC KDB No. 558074 DTS D01 Meas. Guidance v03r05 section 9.1.2 PKPM1 Peak power meter method.
2. The RF output of EUT was connected to the power meter by RF cable and attenuator. The path loss was compensated to the results for each measurement.
3. Set to the maximum power setting and enable the EUT transmit continuously.
4. Measure the conducted output power and record the results in the test report.

3.2.4 Test Setup

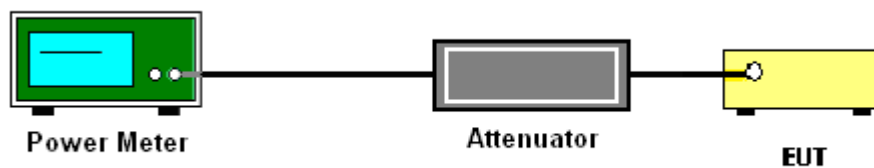

3.2.5 Test Result of Peak Output Power

Please refer to Appendix A of this test report.

3.2.6 Test Result of Average output Power (Reporting Only)

Please refer to Appendix A

3.3 Power Spectral Density Measurement

3.3.1 Limit of Power Spectral Density

The peak power spectral density shall not be greater than 8dBm in any 3kHz band at any time interval of continuous transmission.

3.3.2 Measuring Instruments

The measuring equipment is listed in the section 4 of this test report.

3.3.3 Test Procedures

1. The testing follows Measurement Procedure 10.2 Method PKPSD of FCC KDB Publication No. 558074 D01 DTS Meas. Guidance v03r05.
2. The RF output of EUT was connected to the spectrum analyzer by RF cable and attenuator. The path loss was compensated to the results for each measurement.
3. Set to the maximum power setting and enable the EUT transmit continuously.
4. Make the measurement with the spectrum analyzer's resolution bandwidth (RBW) = 3 kHz. Video bandwidth VBW = 10 kHz In order to make an accurate measurement, set the span to 1.5 times DTS Channel Bandwidth. (6dB BW)
5. Detector = peak, Sweep time = auto couple, Trace mode = max hold, Allow trace to fully stabilize. Use the peak marker function to determine the maximum power level.
6. Measure and record the results in the test report.

3.3.4 Test Setup





3.3.5 Test Result of Power Spectral Density

Please refer to Appendix A.

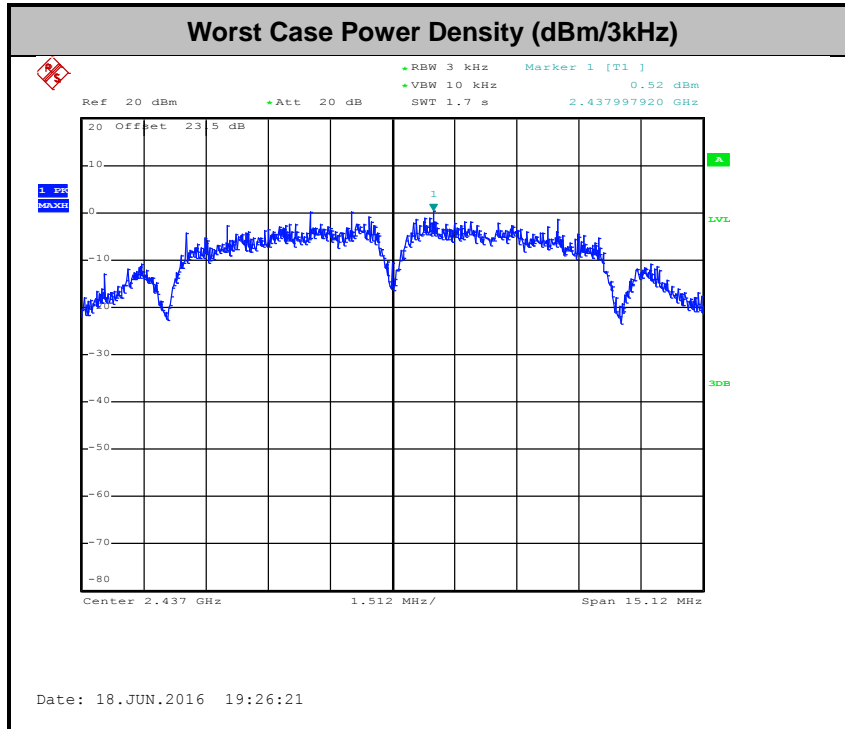

3.4 Conducted Band Edges and Spurious Emission Measurement

3.4.1 Limit of Conducted Band Edges and Spurious Emission Measurement

In any 100 kHz bandwidth outside of the authorized frequency band, the emissions which fall in the non-restricted bands shall be attenuated at least 20 dB / 30dB relative to the maximum PSD level in 100 kHz by RF conducted measurement and radiated emissions which fall in the restricted bands, as defined in Section 15.205(a), must also comply with the radiated emission limits specified in Section 15.209(a).

3.4.2 Measuring Instruments

The measuring equipment is listed in the section 4 of this test report.

3.4.3 Test Procedures

1. The testing follows FCC KDB Publication No. 558074 D01 DTS Meas. Guidance v03r05.
2. The RF output of EUT was connected to the spectrum analyzer by RF cable and attenuator. The path loss was compensated to the results for each measurement.
3. Set to the maximum power setting and enable the EUT transmit continuously.
4. Set RBW = 100 kHz, VBW=300 kHz, Peak Detector. Unwanted Emissions measured in any 100 kHz bandwidth outside of the authorized frequency band shall be attenuated by at least 20 dB relative to the maximum in-band peak PSD level in 100 kHz when maximum peak conducted output power procedure is used. If the transmitter complies with the conducted power limits based on the use of RMS averaging over a time interval, the attenuation required under this paragraph shall be 30 dB instead of 20 dB per 15.247(d).
5. Measure and record the results in the test report.
6. The RF fundamental frequency should be excluded against the limit line in the operating frequency band.

3.4.4 Test Setup

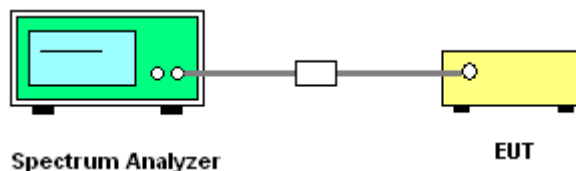



3.4.5 Test Result of Conducted Band Edges and Spurious Emission

Number of TX = 1, Ant. 1 (Measured)

Number of TX	1	Ant. :	1
Test Mode :	802.11b	Temperature :	21~25°C
Test Band :	2.4GHz Low	Relative Humidity :	51~54%
Test Channel :	01	Test Engineer :	Osolemio Chang

WLAN 802.11b Channel 01

100kHz PSD reference Level

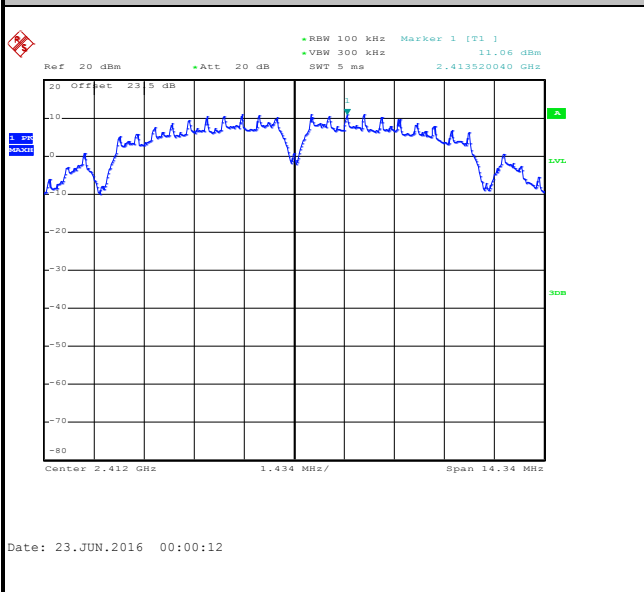

Low Channel Plot

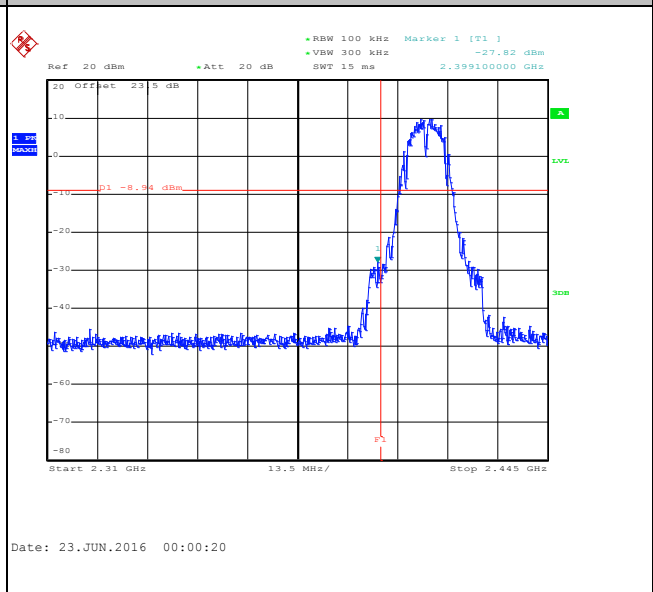

Spurious Emission 30MHz~3GHz

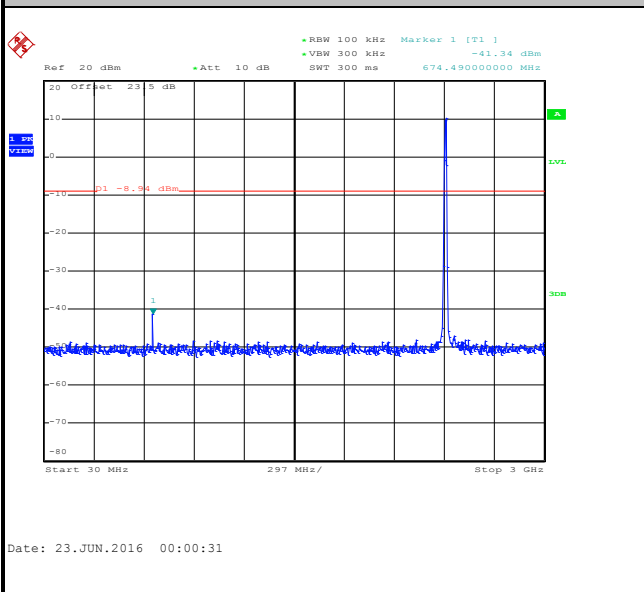

Spurious Emission 2GHz~25GHz

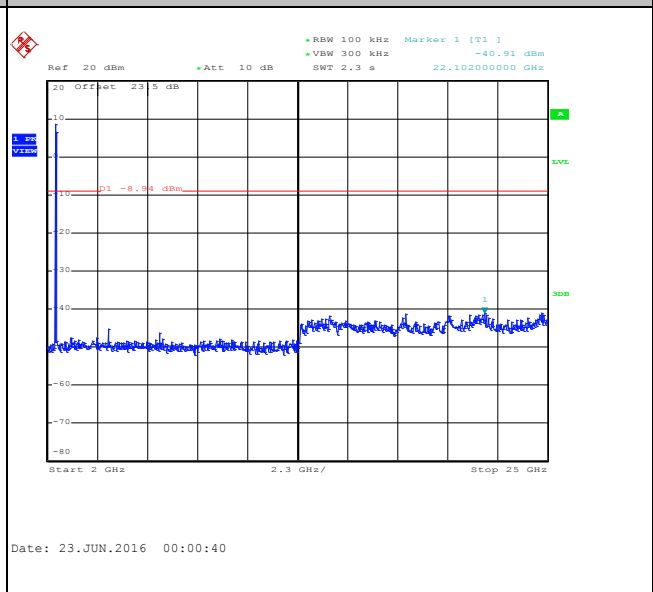



Number of TX :	1	Ant. :	1
Test Mode :	802.11b	Temperature :	21~25°C
Test Band :	2.4GHz Mid	Relative Humidity :	51~54%
Test Channel :	06	Test Engineer :	Osolemio Chang

WLAN 802.11b Channel 06

100kHz PSD reference Level

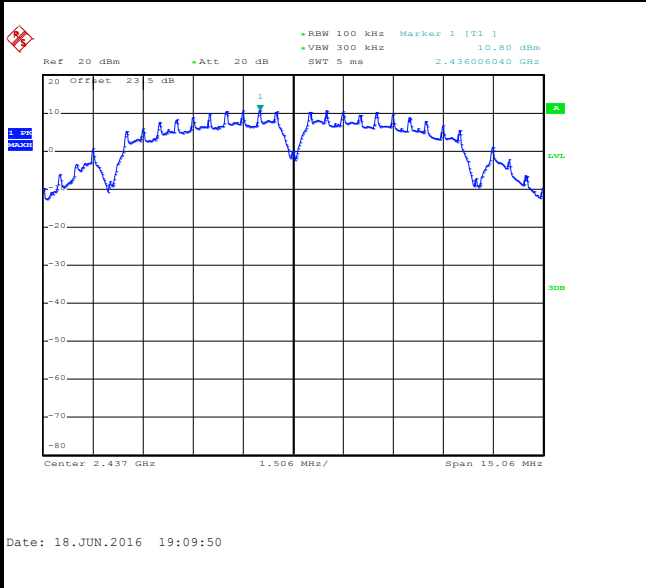

Spurious Emission 30MHz~3GHz

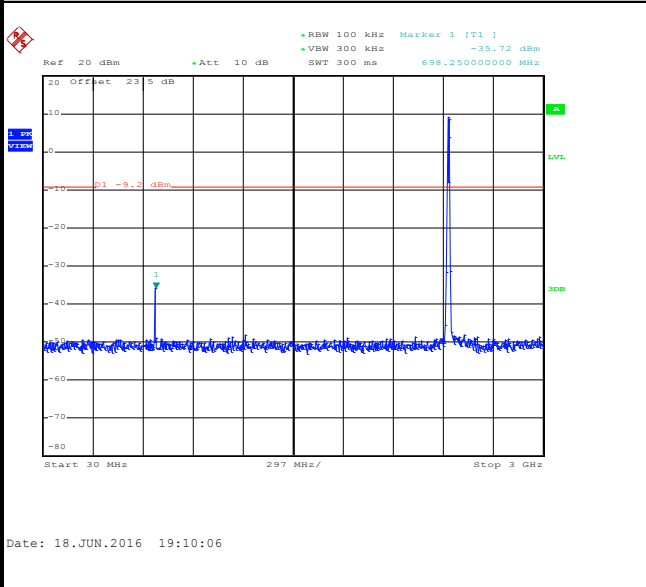

Spurious Emission 2GHz~25GHz

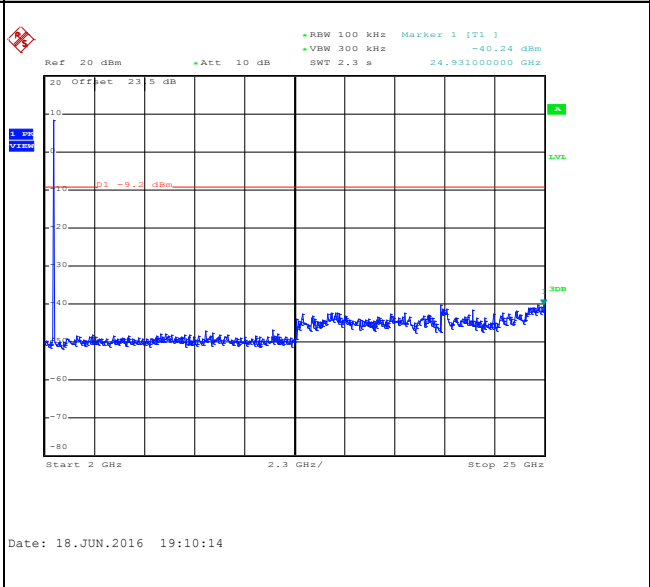



Number of TX :	1	Ant. :	1
Test Mode :	802.11b	Temperature :	21~25°C
Test Band :	2.4GHz High	Relative Humidity :	51~54%
Test Channel :	11	Test Engineer :	Osolemio Chang

WLAN 802.11b Channel 11

100kHz PSD reference Level

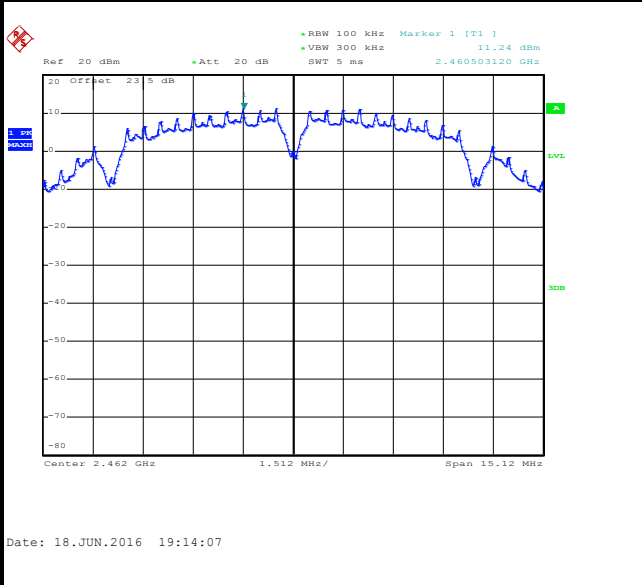

High Channel Plot

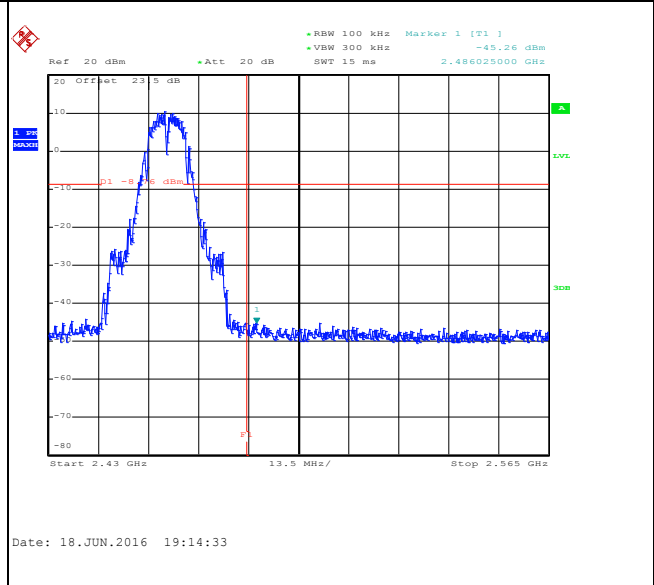

Spurious Emission 30MHz~3GHz

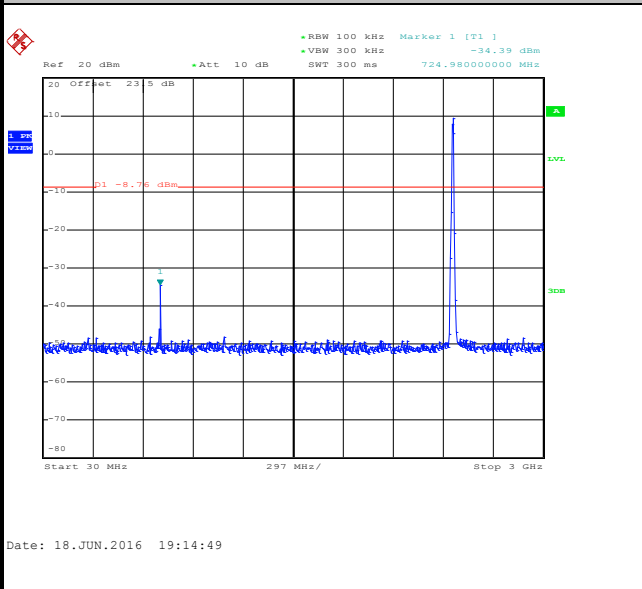

Spurious Emission 2GHz~25GHz

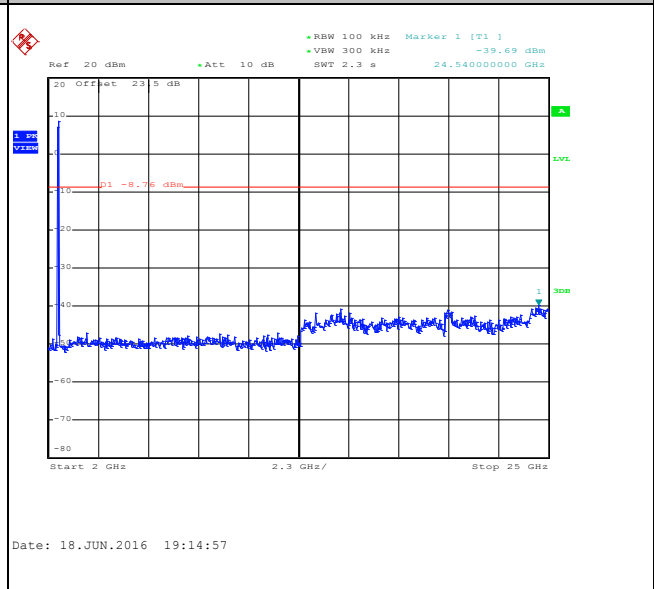



Number of TX :	1	Ant. :	1
Test Mode :	802.11g	Temperature :	21~25°C
Test Band :	2.4GHz Low	Relative Humidity :	51~54%
Test Channel :	01	Test Engineer :	Osolemio Chang

WLAN 802.11g Channel 01

100kHz PSD reference Level

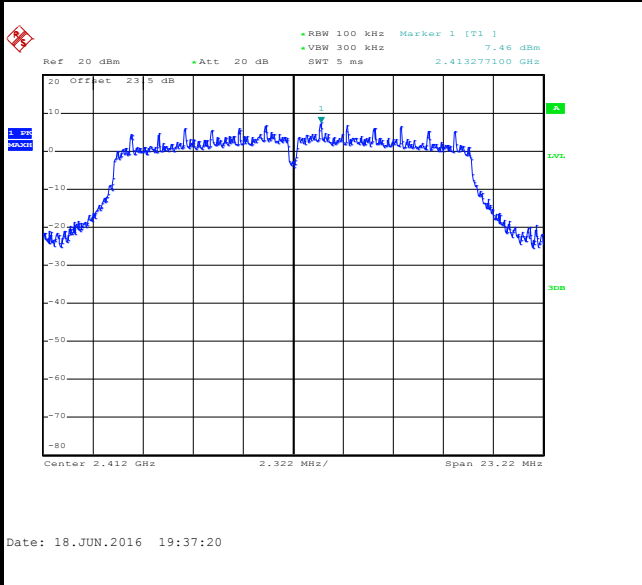

Low Channel Plot

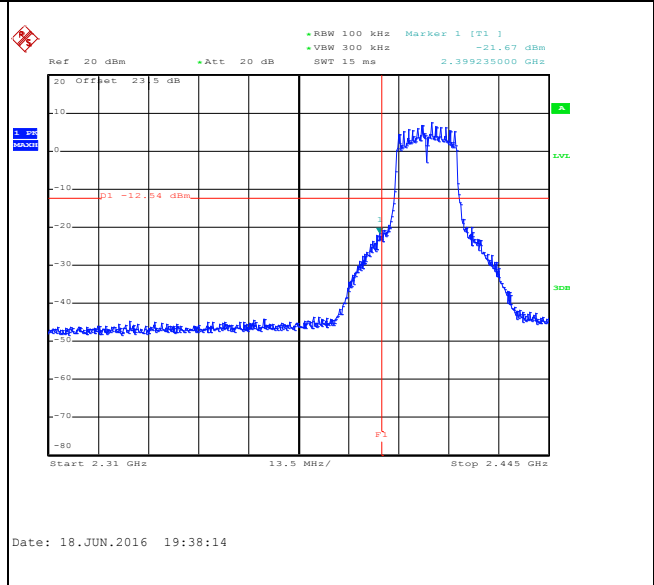

Spurious Emission 30MHz~3GHz

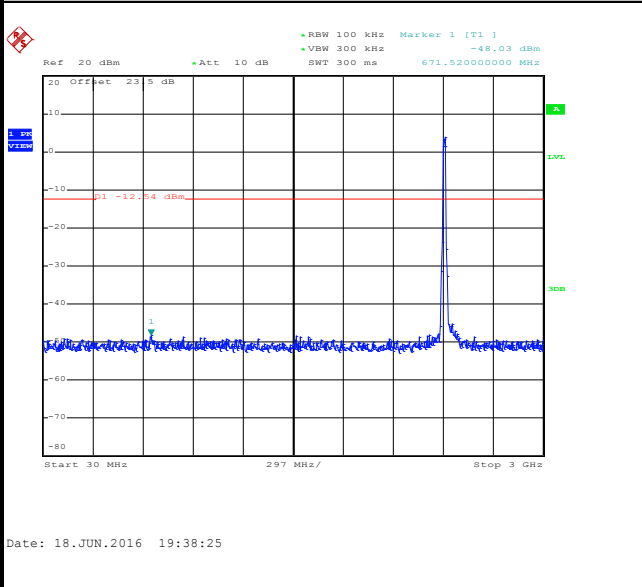

Spurious Emission 2GHz~25GHz

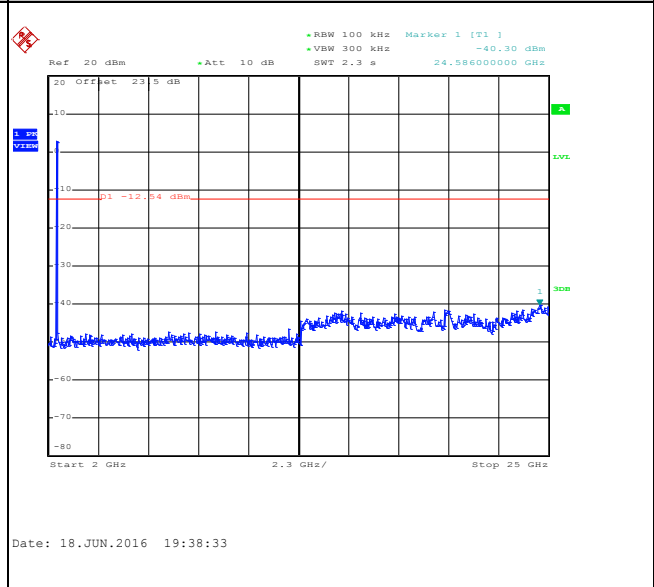



Number of TX :	1	Ant. :	1
Test Mode :	802.11g	Temperature :	21~25°C
Test Band :	2.4GHz Mid	Relative Humidity :	51~54%
Test Channel :	06	Test Engineer :	Osolemio Chang

WLAN 802.11g Channel 06

100kHz PSD reference Level

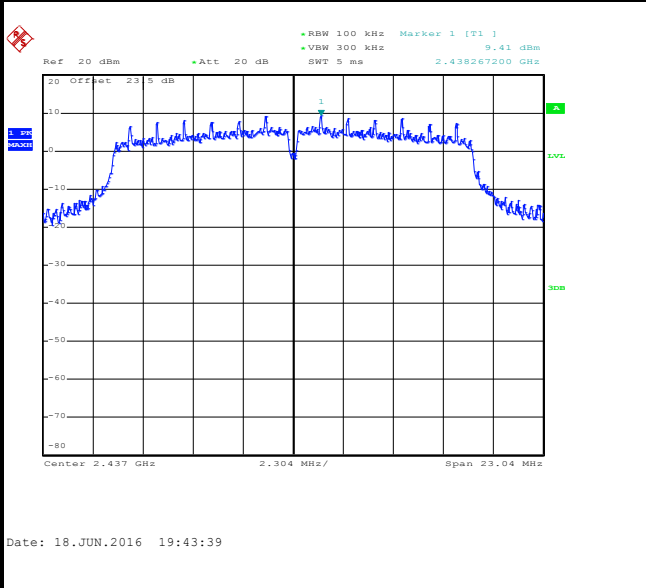

Spurious Emission 30MHz~3GHz

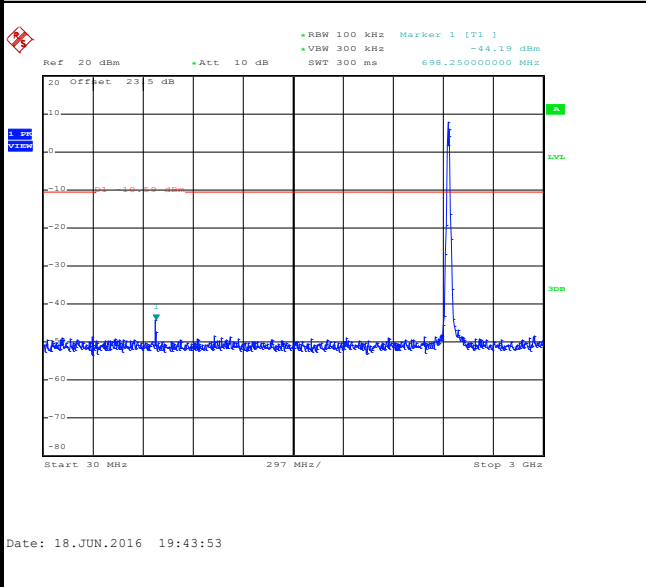

Spurious Emission 2GHz~25GHz

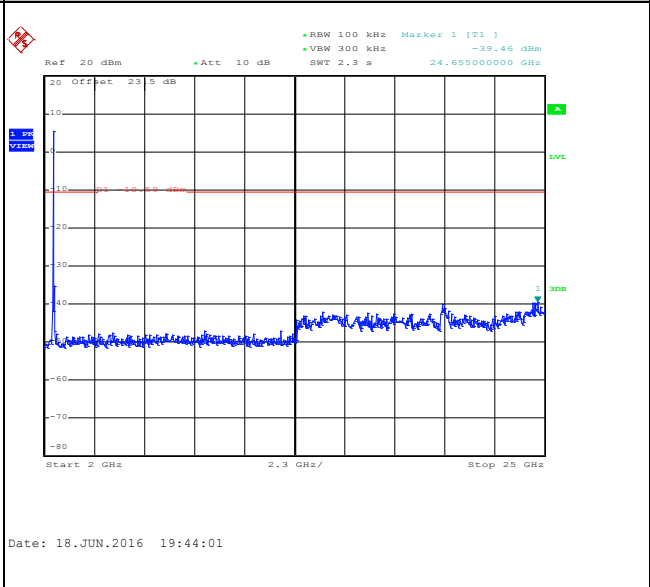



Number of TX :	1	Ant. :	1
Test Mode :	802.11g	Temperature :	21~25°C
Test Band :	2.4GHz High	Relative Humidity :	51~54%
Test Channel :	11	Test Engineer :	Osolemio Chang

WLAN 802.11g Channel 11

100kHz PSD reference Level

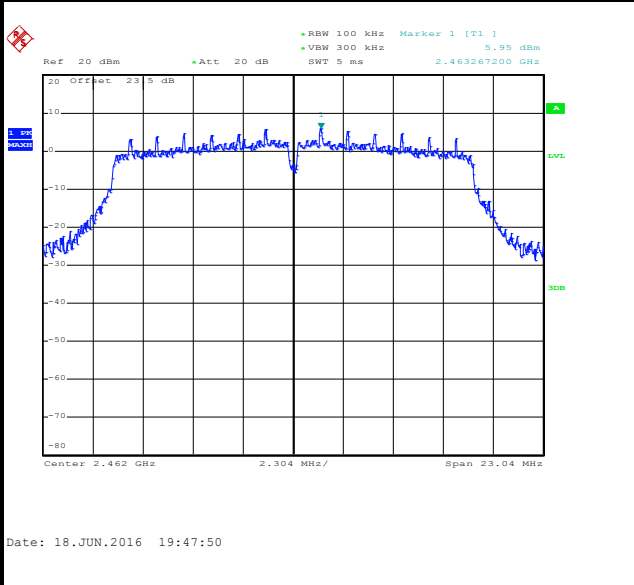

High Channel Plot

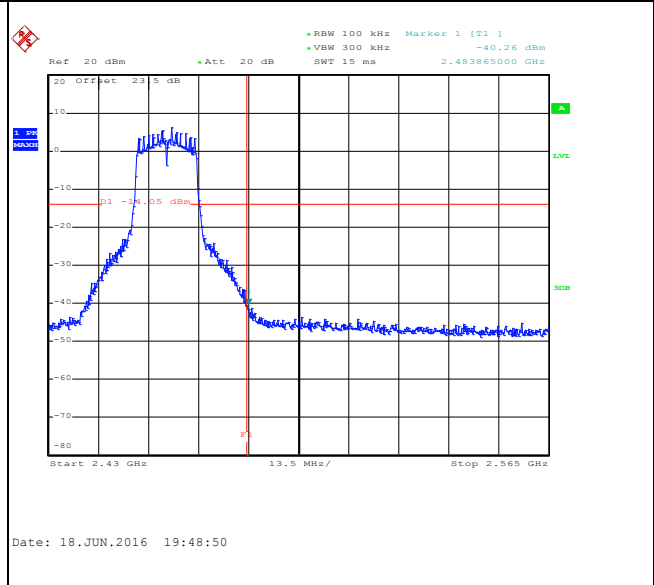

Spurious Emission 30MHz~3GHz

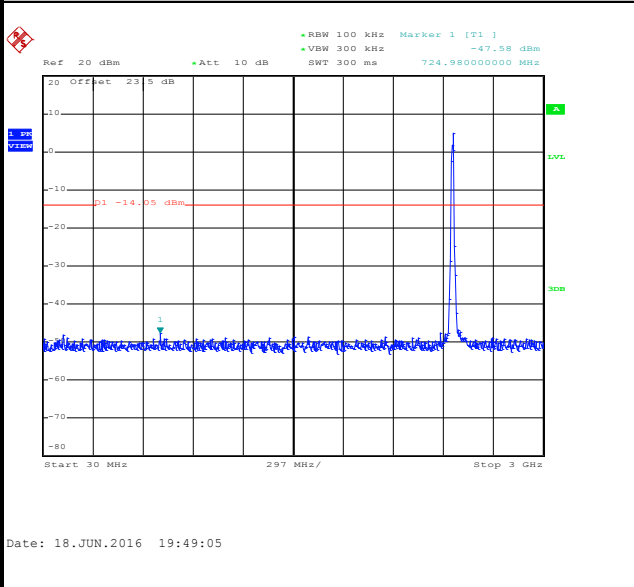

Spurious Emission 2GHz~25GHz

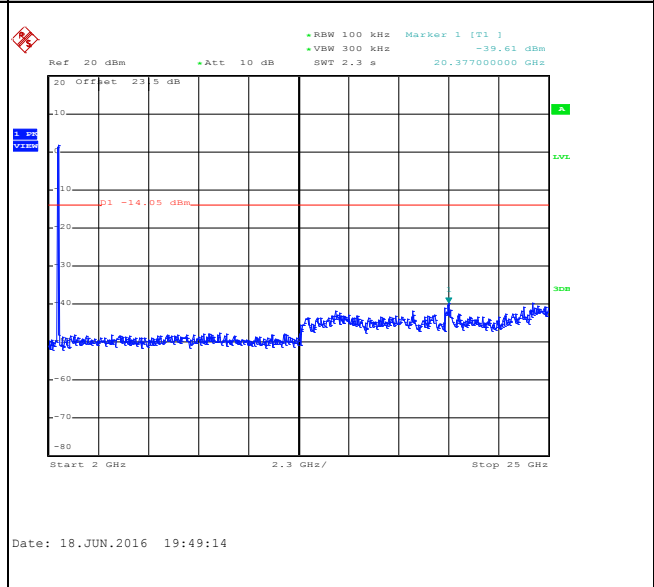



Number of TX :	1	Ant. :	1
Test Mode :	802.11n HT20	Temperature :	21~25°C
Test Band :	2.4GHz Low	Relative Humidity :	51~54%
Test Channel :	01	Test Engineer :	Osolemio Chang

WLAN 802.11n HT20 Channel 01

100kHz PSD reference Level

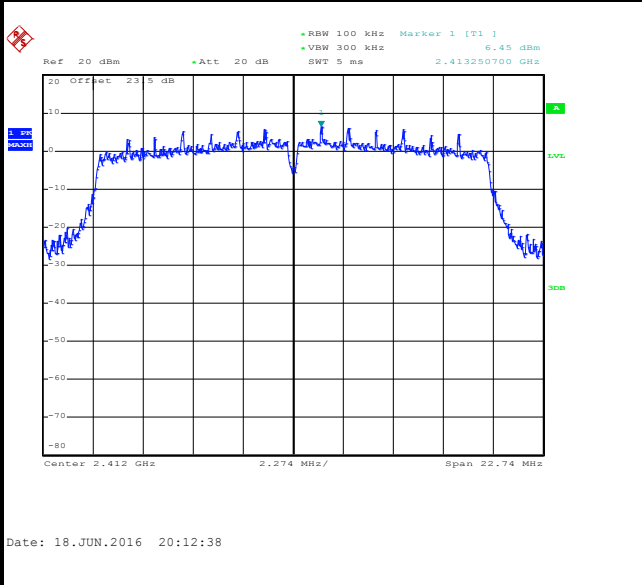

Low Channel Plot

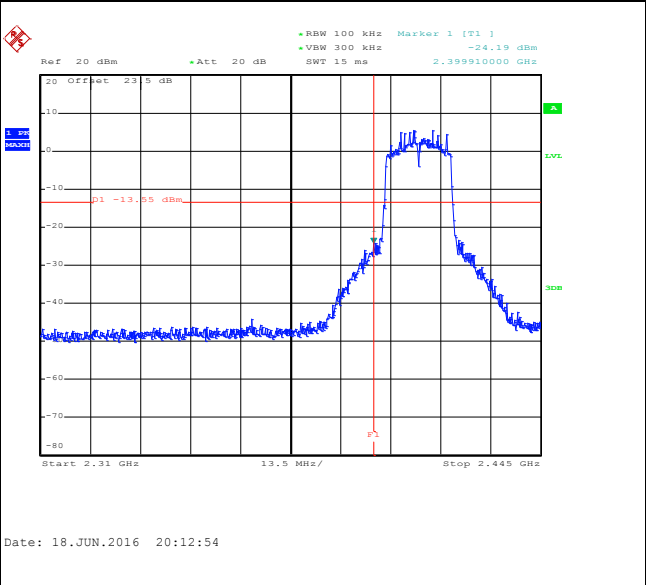

Spurious Emission 30MHz~3GHz

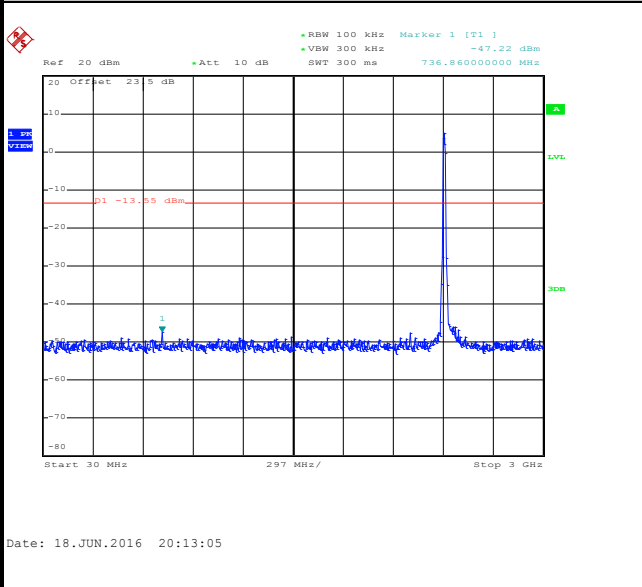

Spurious Emission 2GHz~25GHz

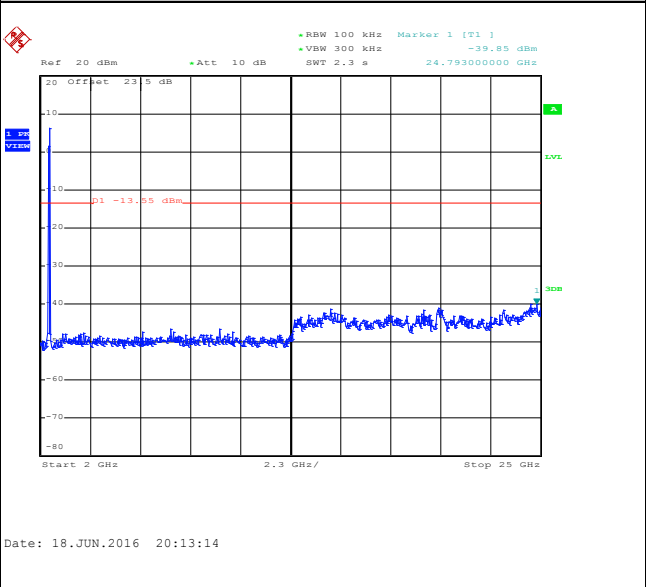



Number of TX :	1	Ant. :	1
Test Mode :	802.11n HT20	Temperature :	21~25°C
Test Band :	2.4GHz Mid	Relative Humidity :	51~54%
Test Channel :	06	Test Engineer :	Osolemio Chang

WLAN 802.11n HT20 Channel 06

100kHz PSD reference Level

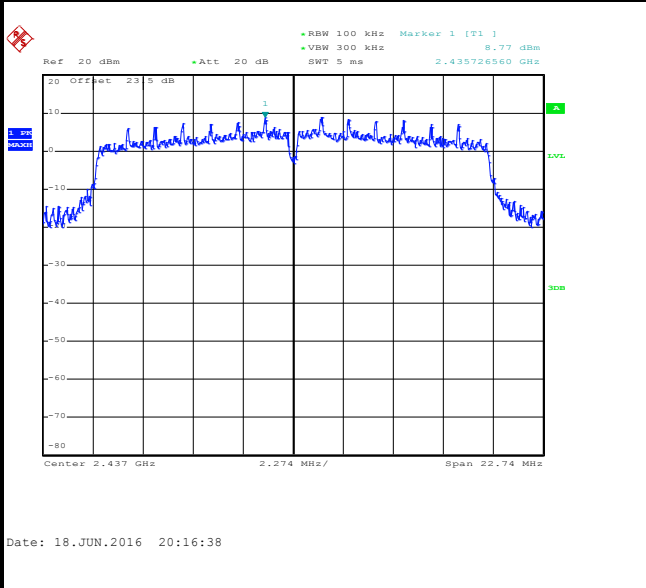

Spurious Emission 30MHz~3GHz

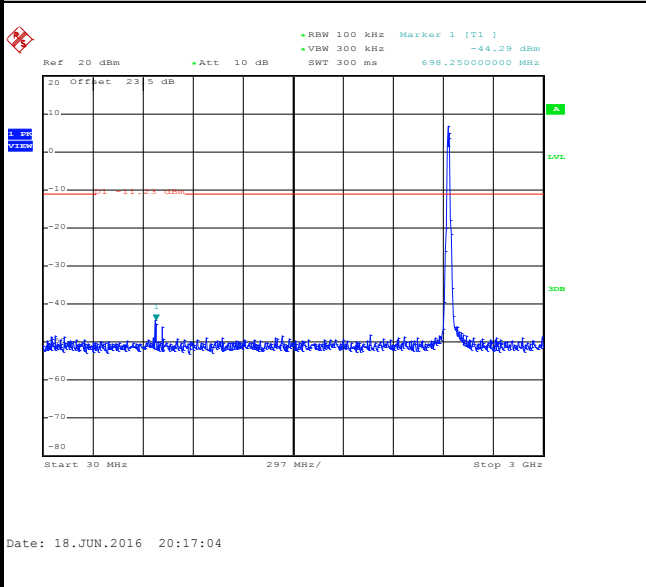

Spurious Emission 2GHz~25GHz

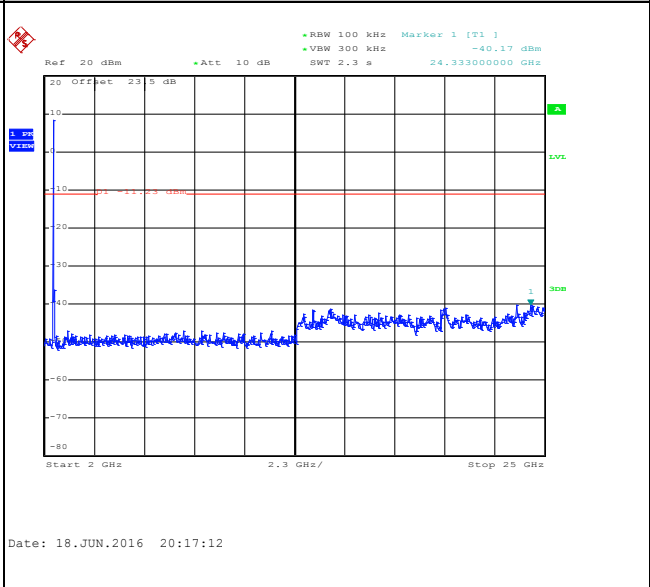



Number of TX :	1	Ant. :	1
Test Mode :	802.11n HT20	Temperature :	21~25°C
Test Band :	2.4GHz High	Relative Humidity :	51~54%
Test Channel :	11	Test Engineer :	Osolemio Chang

WLAN 802.11n HT20 Channel 11

100kHz PSD reference Level

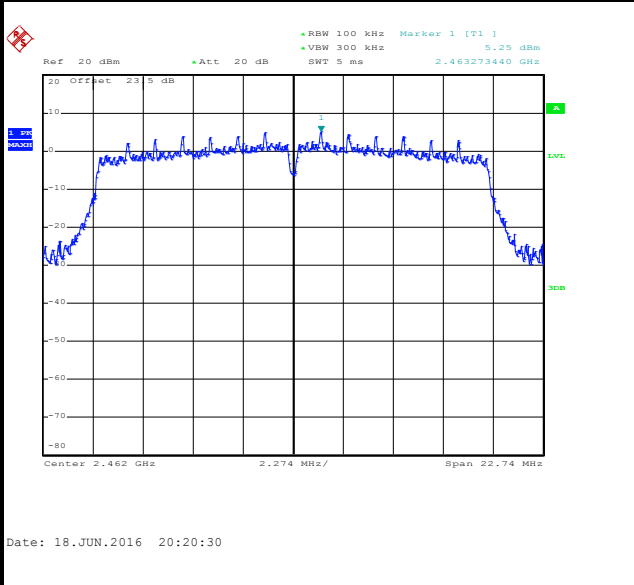

High Channel Plot

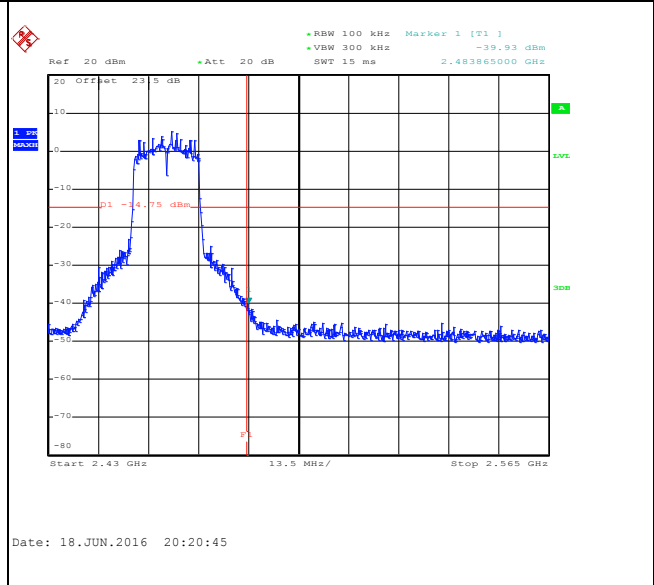

Spurious Emission 30MHz~3GHz

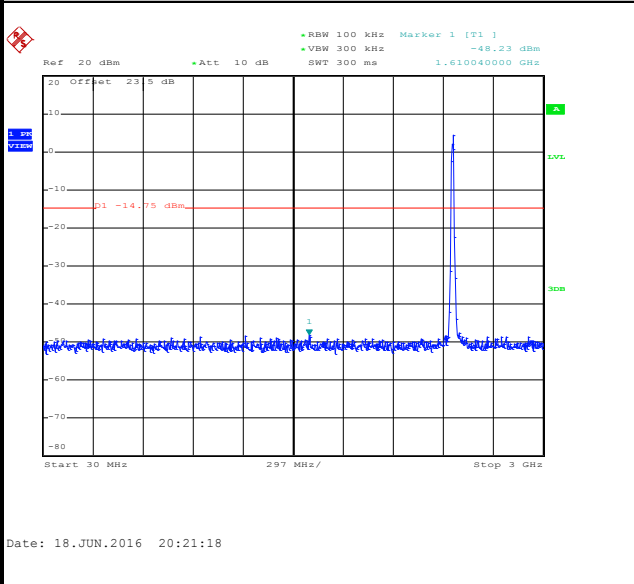

Spurious Emission 2GHz~25GHz

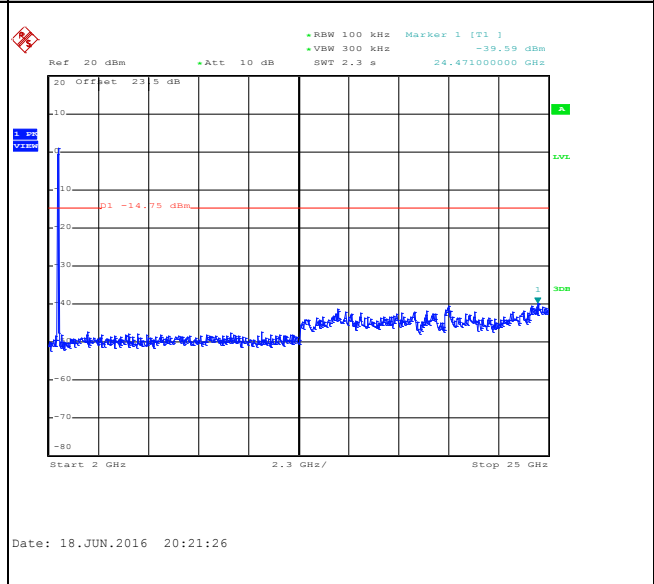



Number of TX = 1, Ant. 2 (Measured)

Number of TX :	1	Ant. :	2
Test Mode :	802.11b	Temperature :	21~25°C
Test Band :	2.4GHz Low	Relative Humidity :	51~54%
Test Channel :	01	Test Engineer :	Osolemio Chang

WLAN 802.11b Channel 01

100kHz PSD reference Level

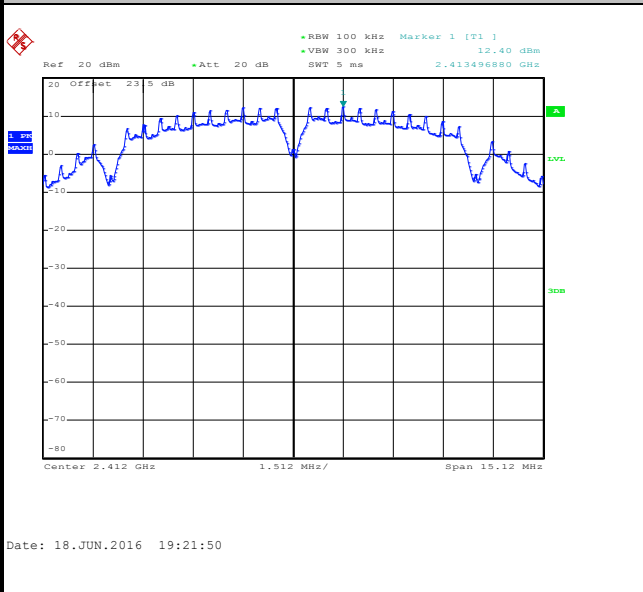

Low Channel Plot

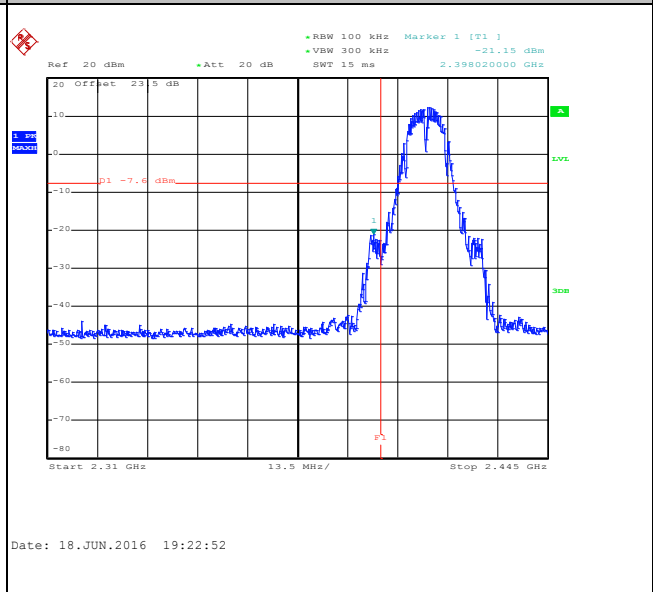

Spurious Emission 30MHz~3GHz

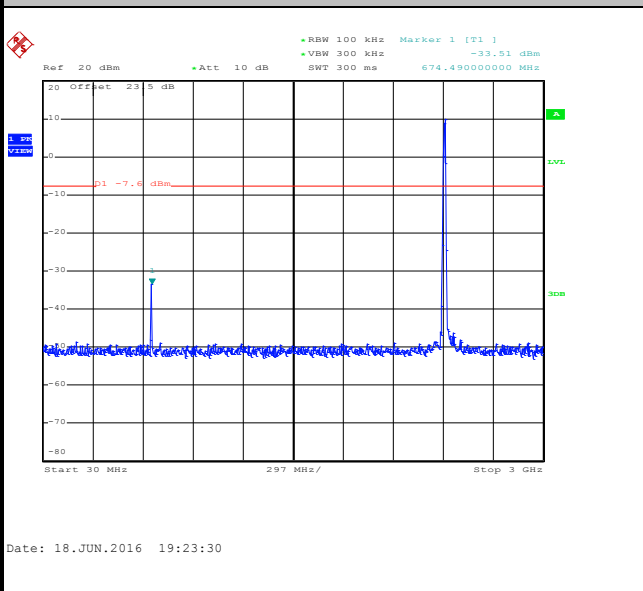

Spurious Emission 2GHz~25GHz

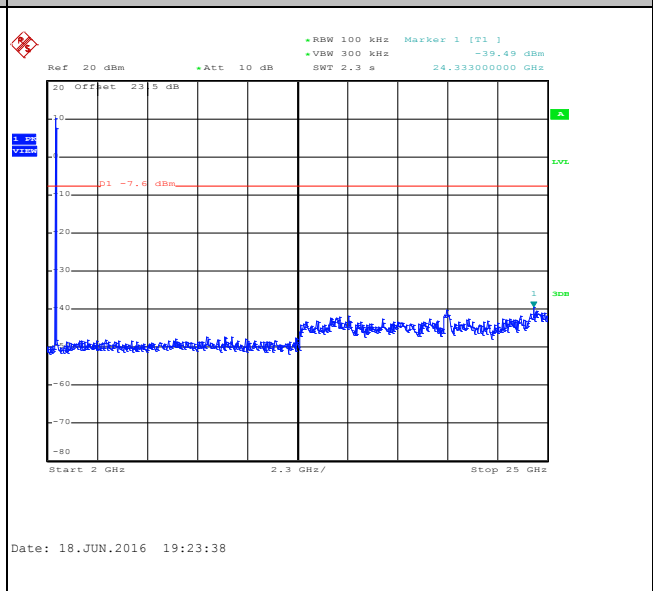



Number of TX :	1	Ant. :	2
Test Mode :	802.11b	Temperature :	21~25°C
Test Band :	2.4GHz Mid	Relative Humidity :	51~54%
Test Channel :	06	Test Engineer :	Osolemio Chang

WLAN 802.11b Channel 06

100kHz PSD reference Level

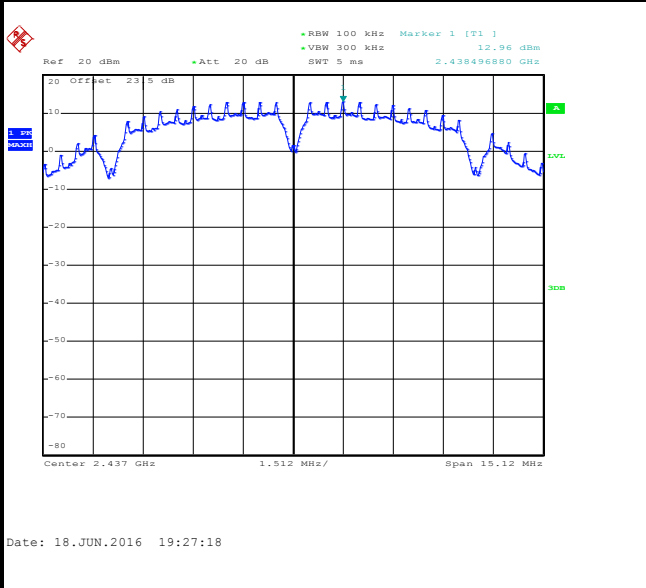

Spurious Emission 30MHz~3GHz

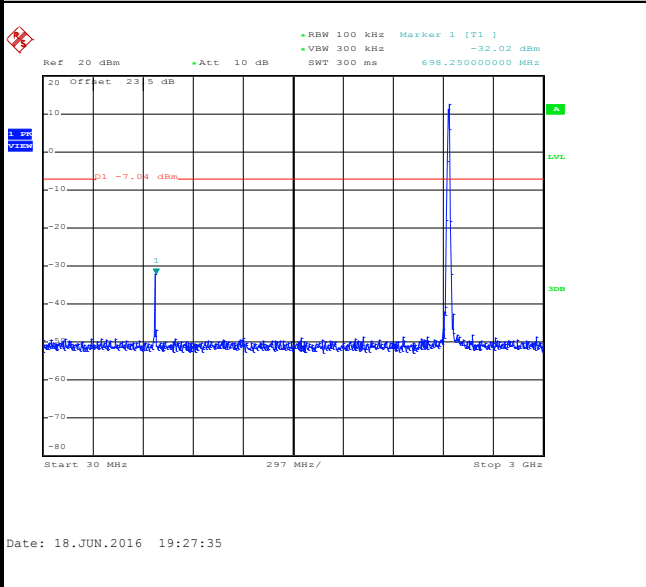

Spurious Emission 2GHz~25GHz

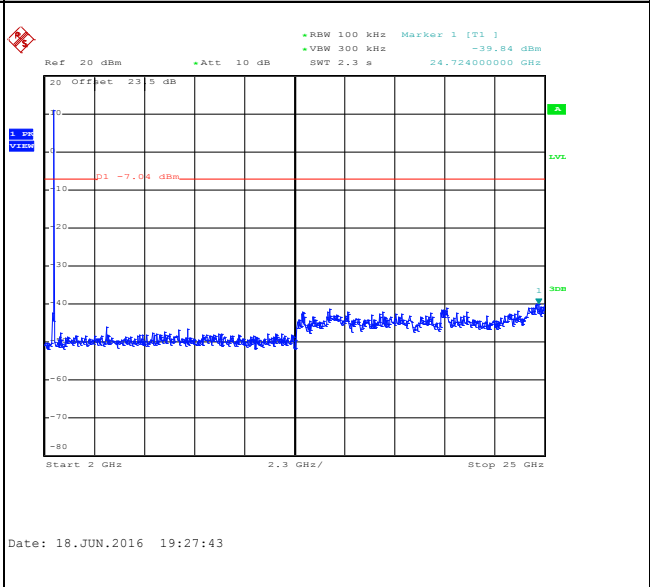



Number of TX :	1	Ant. :	2
Test Mode :	802.11b	Temperature :	21~25°C
Test Band :	2.4GHz High	Relative Humidity :	51~54%
Test Channel :	11	Test Engineer :	Osolemio Chang

WLAN 802.11b Channel 11

100kHz PSD reference Level

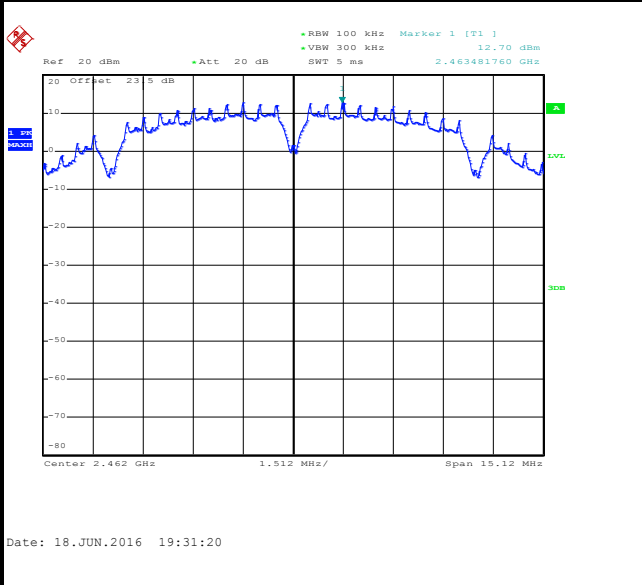

High Channel Plot

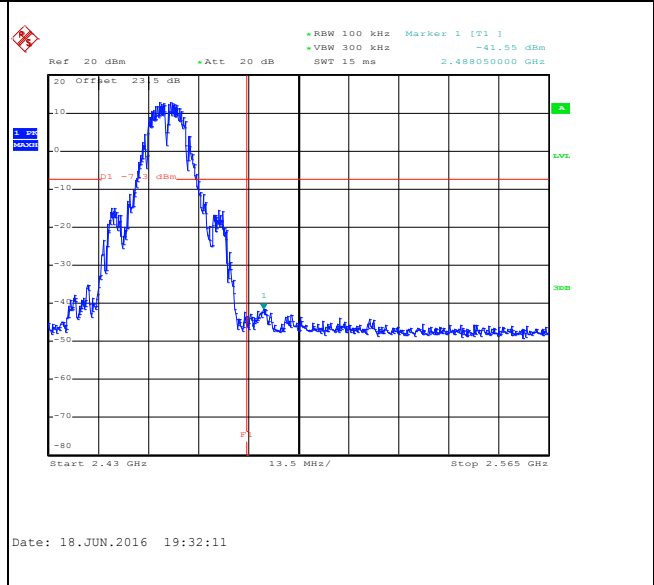

Spurious Emission 30MHz~3GHz

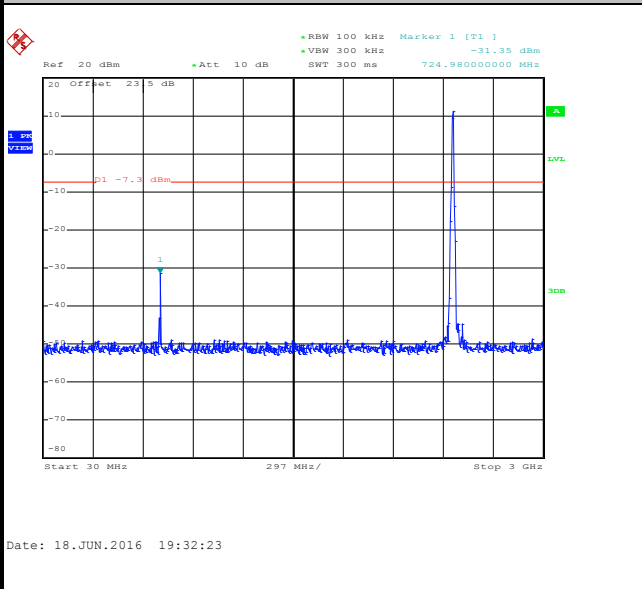

Spurious Emission 2GHz~25GHz

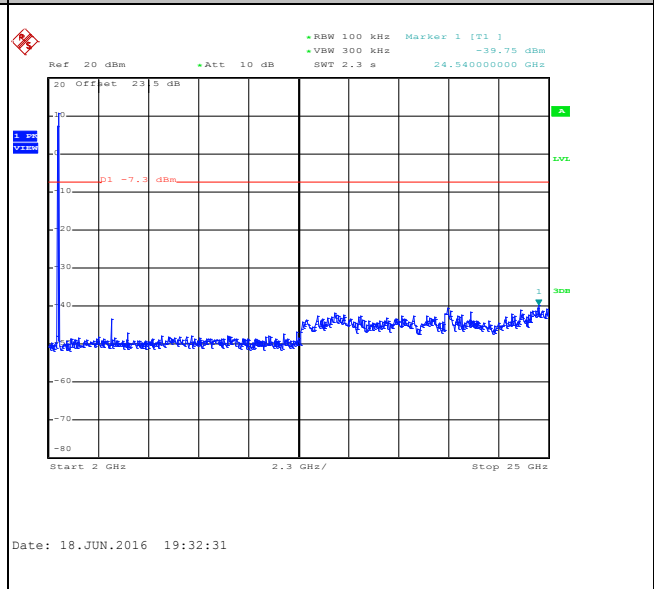



Number of TX :	1	Ant. :	2
Test Mode :	802.11g	Temperature :	21~25°C
Test Band :	2.4GHz Low	Relative Humidity :	51~54%
Test Channel :	01	Test Engineer :	Osolemio Chang

WLAN 802.11g Channel 01

100kHz PSD reference Level

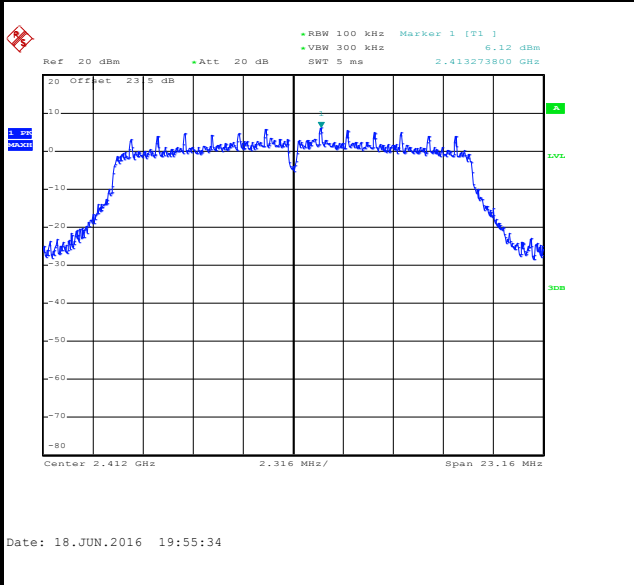

Low Channel Plot

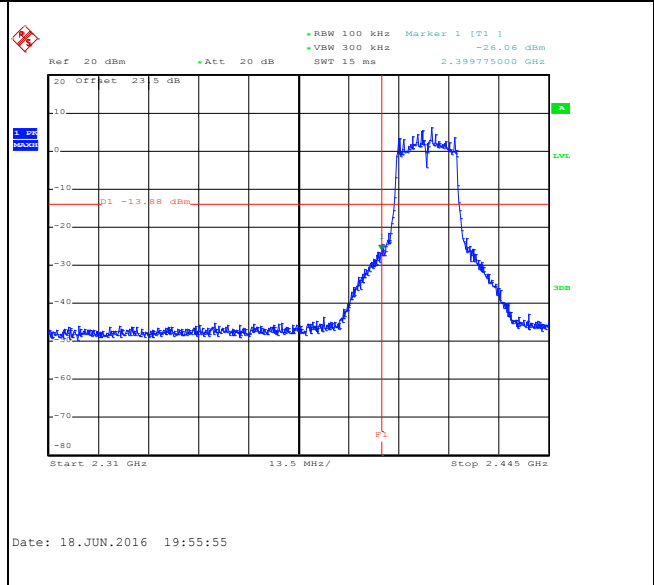

Spurious Emission 30MHz~3GHz

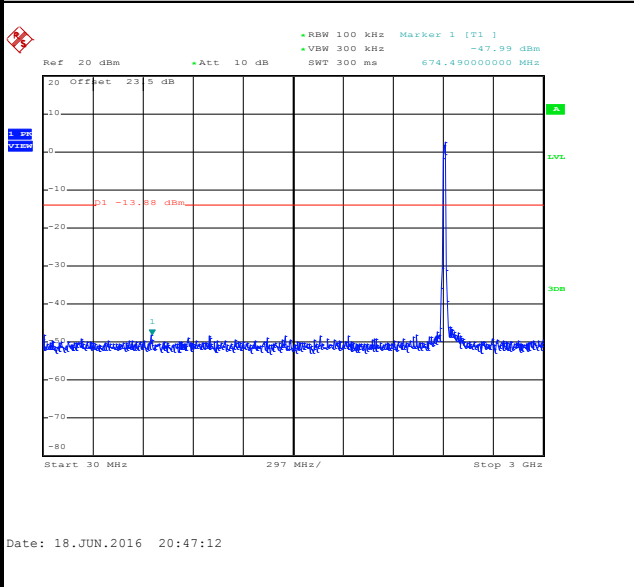

Spurious Emission 2GHz~25GHz

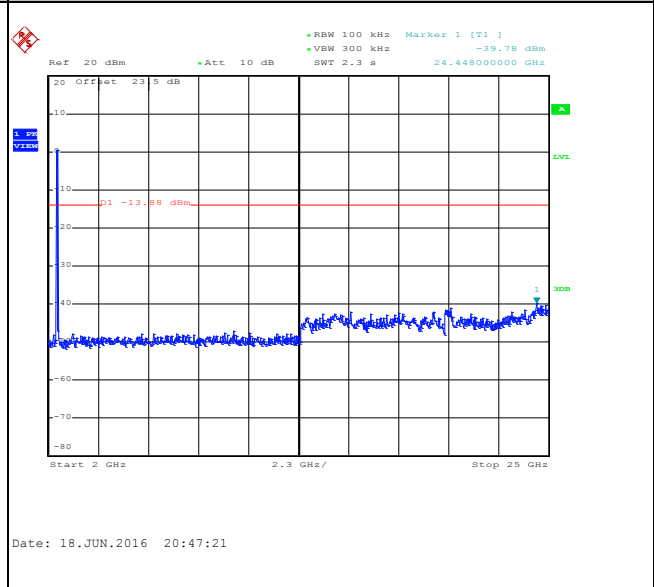



Number of TX :	1	Ant. :	2
Test Mode :	802.11g	Temperature :	21~25°C
Test Band :	2.4GHz Mid	Relative Humidity :	51~54%
Test Channel :	06	Test Engineer :	Osolemio Chang

WLAN 802.11g Channel 06

100kHz PSD reference Level

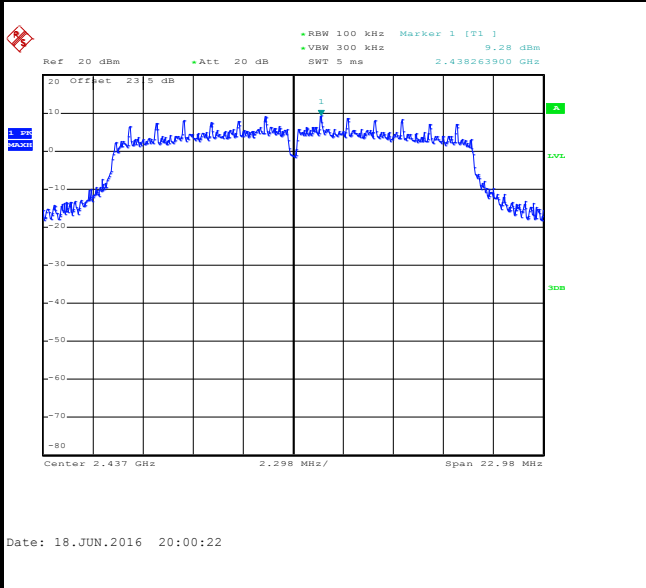

Spurious Emission 30MHz~3GHz

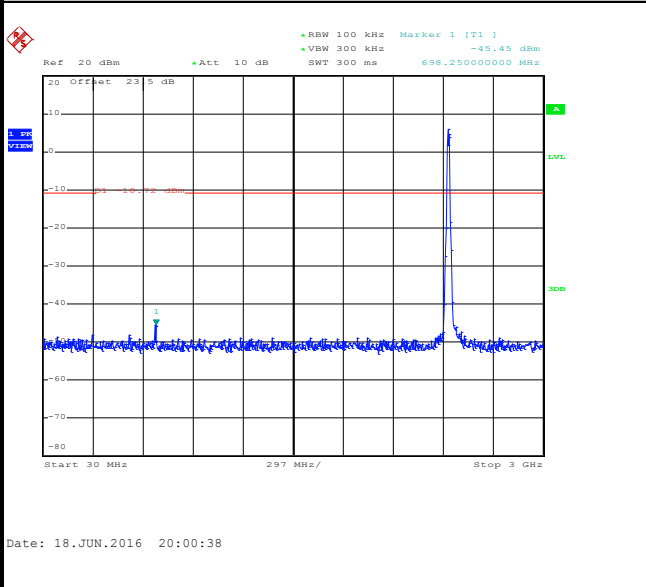

Spurious Emission 2GHz~25GHz

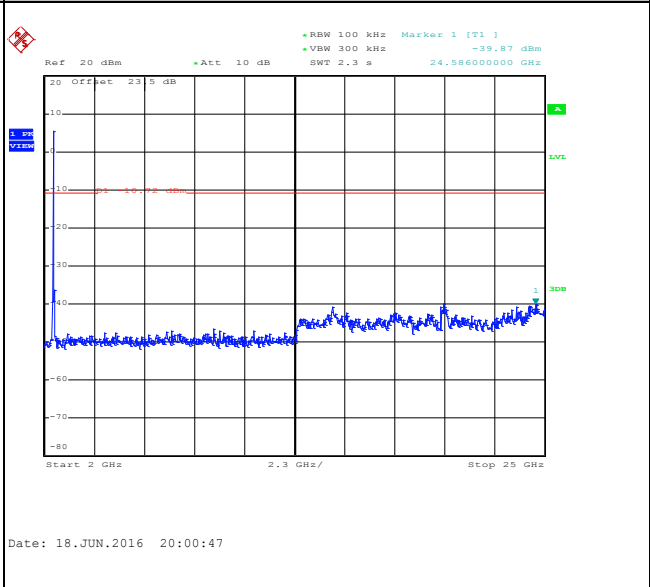



Number of TX :	1	Ant. :	2
Test Mode :	802.11g	Temperature :	21~25°C
Test Band :	2.4GHz High	Relative Humidity :	51~54%
Test Channel :	11	Test Engineer :	Osolemio Chang

WLAN 802.11g Channel 11

100kHz PSD reference Level

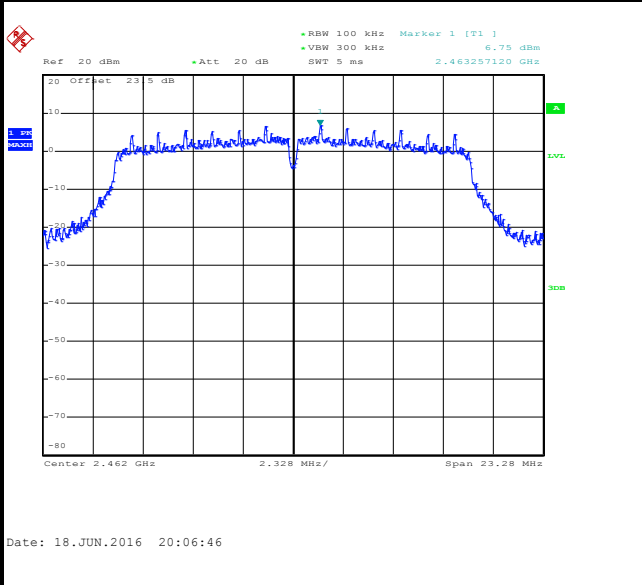

High Channel Plot

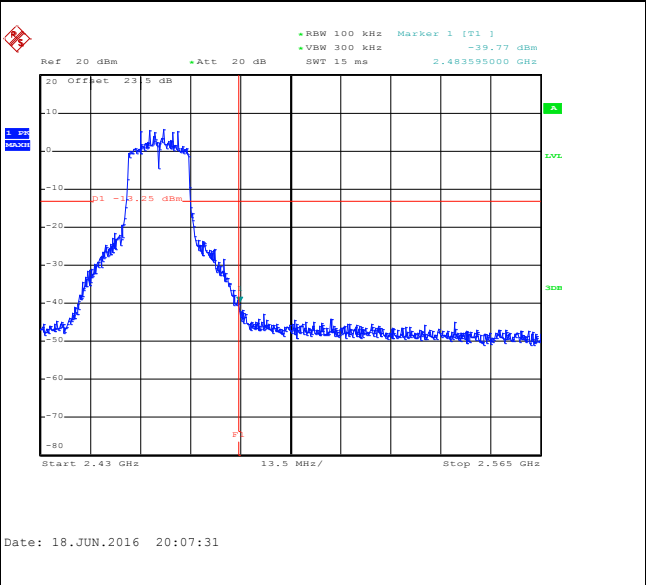

Spurious Emission 30MHz~3GHz

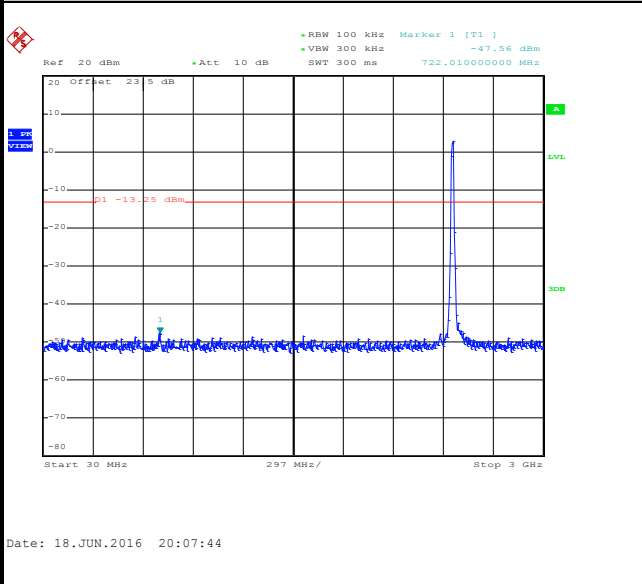

Spurious Emission 2GHz~25GHz

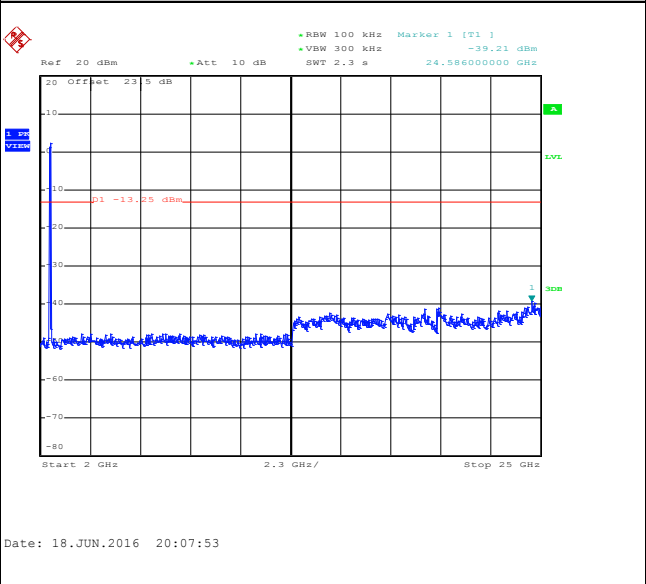



Number of TX :	1	Ant. :	2
Test Mode :	802.11n HT20	Temperature :	21~25°C
Test Band :	2.4GHz Low	Relative Humidity :	51~54%
Test Channel :	01	Test Engineer :	Osolemio Chang

WLAN 802.11n HT20 Channel 01

100kHz PSD reference Level

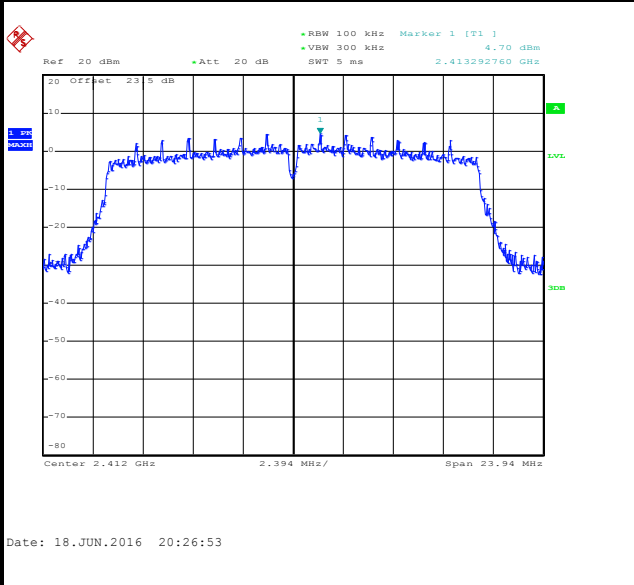

Low Channel Plot

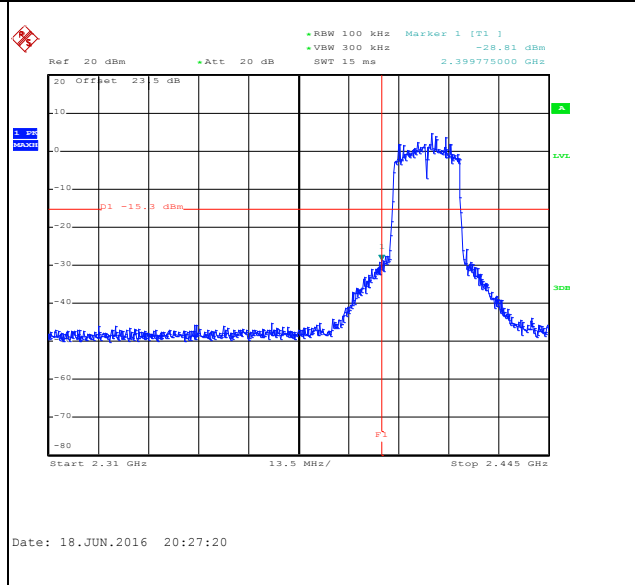

Spurious Emission 30MHz~3GHz

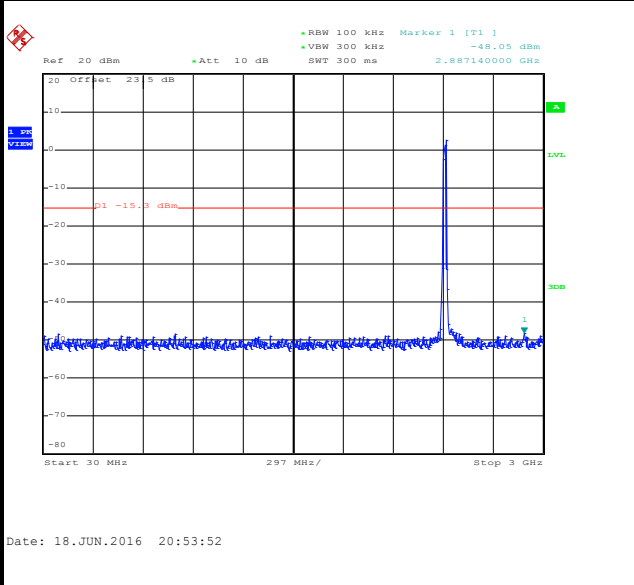

Spurious Emission 2GHz~25GHz

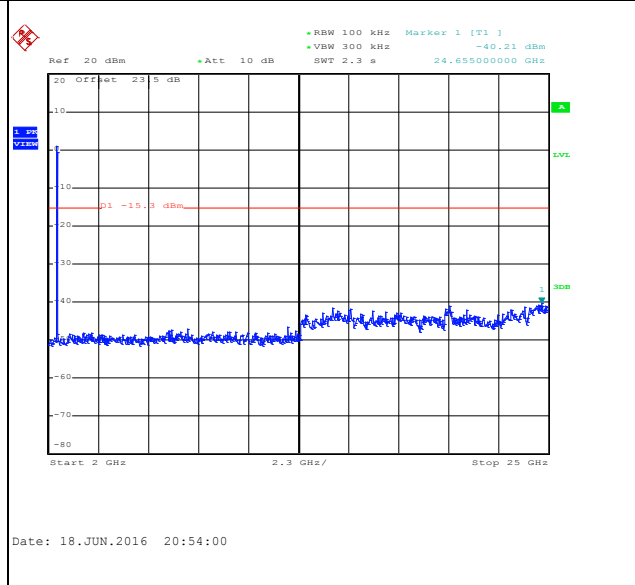



Number of TX :	1	Ant. :	2
Test Mode :	802.11n HT20	Temperature :	21~25°C
Test Band :	2.4GHz Mid	Relative Humidity :	51~54%
Test Channel :	06	Test Engineer :	Osolemio Chang

WLAN 802.11n HT20 Channel 06

100kHz PSD reference Level

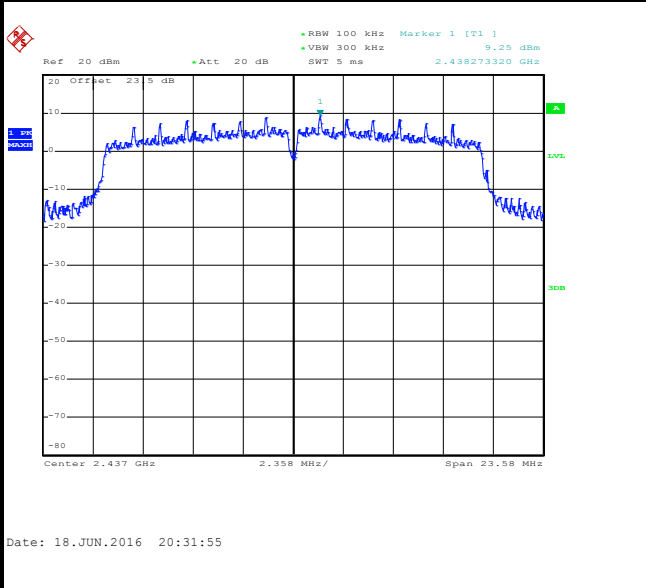

Spurious Emission 30MHz~3GHz

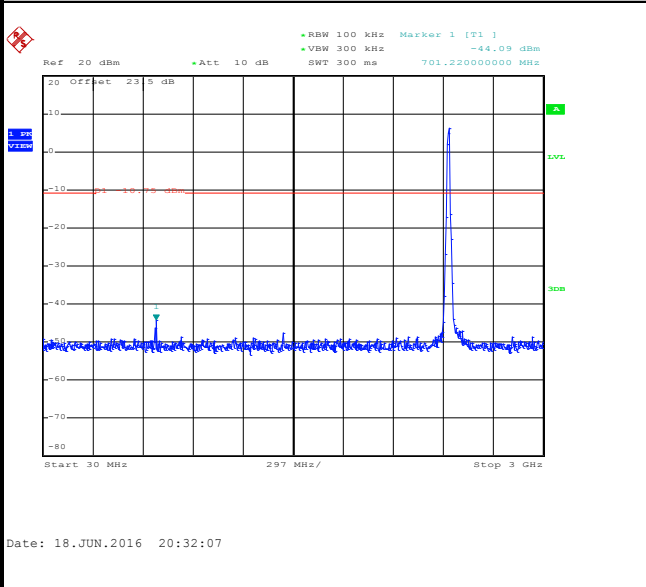

Spurious Emission 2GHz~25GHz

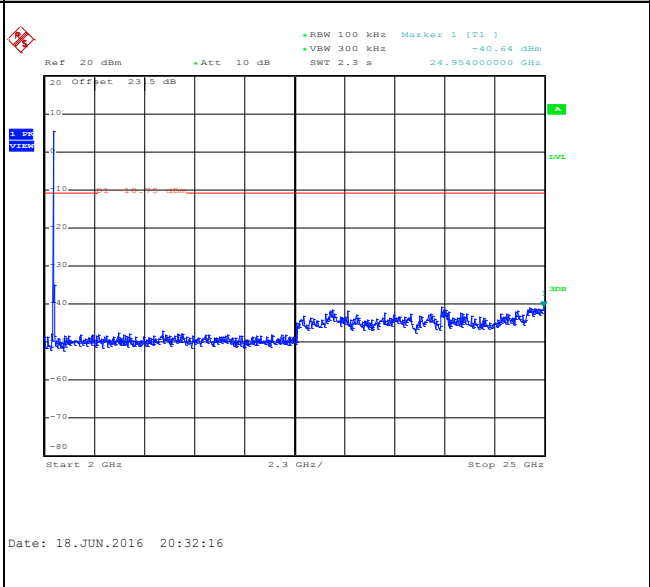



Number of TX :	1	Ant. :	2
Test Mode :	802.11n HT20	Temperature :	21~25°C
Test Band :	2.4GHz High	Relative Humidity :	51~54%
Test Channel :	11	Test Engineer :	Osolemio Chang

WLAN 802.11n HT20 Channel 11

100kHz PSD reference Level

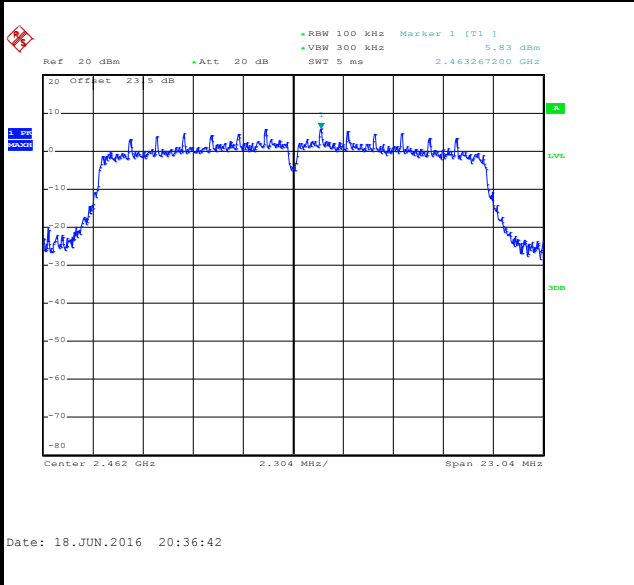

High Channel Plot

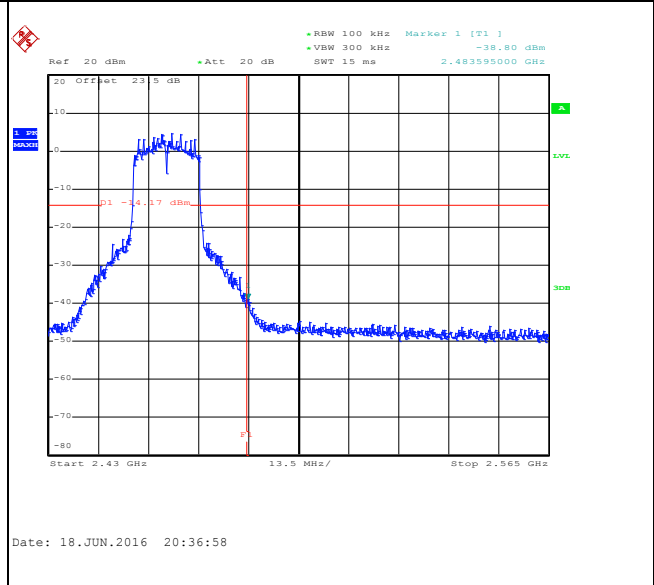

Spurious Emission 30MHz~3GHz

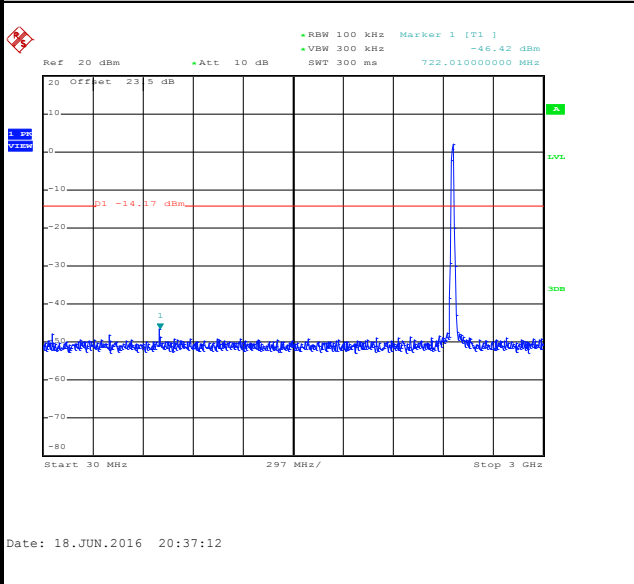

Spurious Emission 2GHz~25GHz

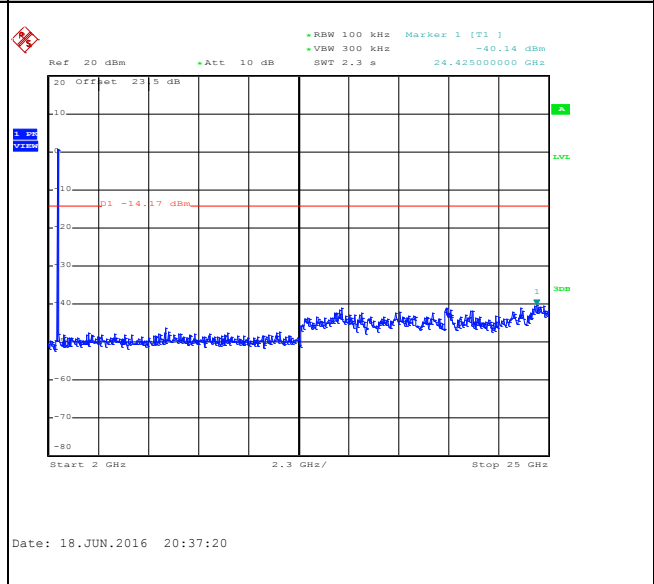



3.5 Radiated Band Edges and Spurious Emission Measurement

3.5.1 Limit of Radiated band edge and Spurious Emission Measurement

In any 100 kHz bandwidth outside the intentional radiator frequency band, all harmonics/spurious must be at least 20 dB below the highest emission level within the authorized band. If the output power of this device was measured by spectrum analyzer, the attenuation under this paragraph shall be 30 dB instead of 20 dB. In addition, radiated emissions which fall in the restricted bands must also comply with the FCC section 15.209 limits as below.

Frequency (MHz)	Field Strength (microvolts/meter)	Measurement Distance (meters)
0.009 – 0.490	2400/F(kHz)	300
0.490 – 1.705	24000/F(kHz)	30
1.705 – 30.0	30	30
30 – 88	100	3
88 – 216	150	3
216 - 960	200	3
Above 960	500	3

3.5.2 Measuring Instruments

The measuring equipment is listed in the section 4 of this test report.



3.5.3 Test Procedure

1. The testing follows FCC KDB Publication No. 558074 D01 DTS Meas. Guidance v03r05.
2. The EUT was arranged to its worst case and then tune the antenna tower (from 1 m to 4 m) and turntable (from 0 degree to 360 degrees) to find the maximum reading. A pre-amp and a high pass filter are used for the test in order to get better signal level.
3. The EUT was placed on a turntable with 0.8 meter for frequency below 1GHz and 1.5 meter for frequency above 1GHz respectively above ground.
4. The EUT was set 3 meters from the interference receiving antenna, which was mounted on the top of a variable height antenna tower.
5. Corrected Reading: $\text{Antenna Factor} + \text{Cable Loss} + \text{Read Level} - \text{Preamp Factor} = \text{Level}$
6. For measurement below 1GHz, If the emission level of the EUT measured by the peak detector is 3 dB lower than the applicable limit, the peak emission level will be reported. Otherwise, the emission measurement will be repeated using the quasi-peak detector and reported.
7. Use the following spectrum analyzer settings:
 - (1) Span shall wide enough to fully capture the emission being measured;
 - (2) Set $\text{RBW}=100 \text{ kHz}$ for $f < 1 \text{ GHz}$; $\text{VBW} \geq \text{RBW}$; Sweep = auto; Detector function = peak; Trace = max hold;
 - (3) Set $\text{RBW} = 1 \text{ MHz}$, $\text{VBW}= 3\text{MHz}$ for $f \geq 1 \text{ GHz}$ for peak measurement.
For average measurement:
 - $\text{VBW} = 10 \text{ Hz}$, when duty cycle is no less than 98 percent.
 - $\text{VBW} \geq 1/T$, when duty cycle is less than 98 percent where T is the minimum transmission duration over which the transmitter is on and is transmitting at its maximum power control level for the tested mode of operation.

3.5.4 Test Setup

For radiated emissions below 30MHz



For radiated emissions from 30MHz to 1GHz

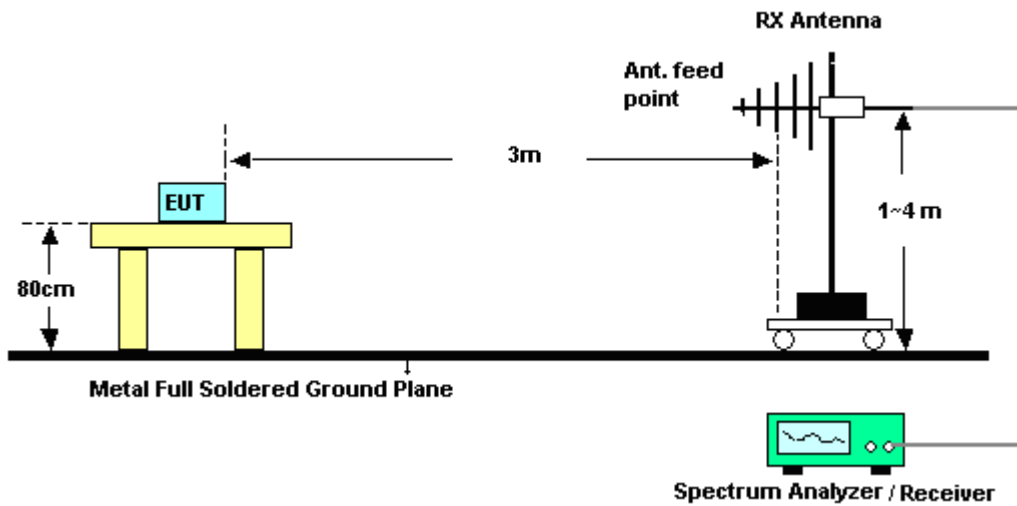

For radiated emissions above 1GHz

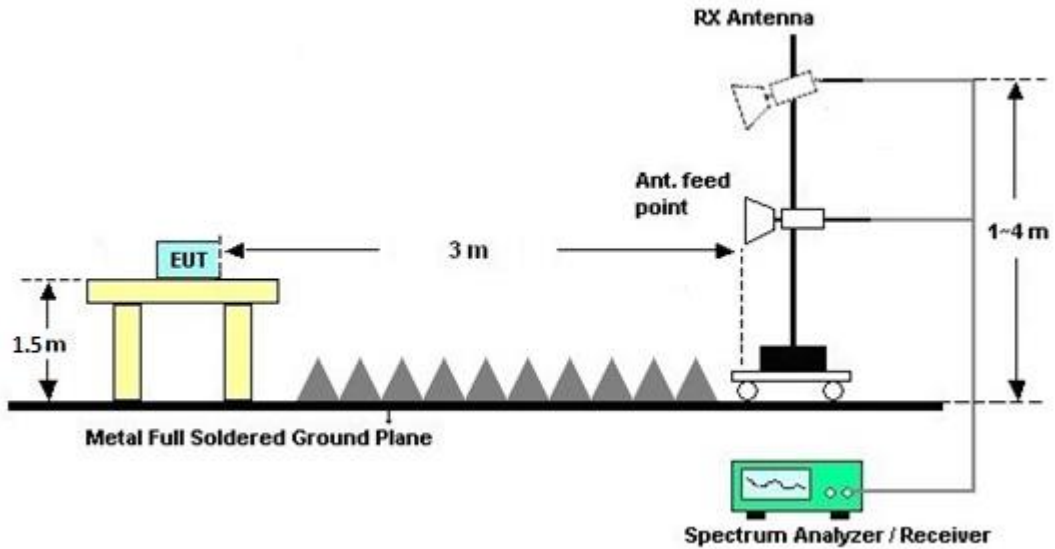

3.5.5 Test Results of Radiated Emissions (9kHz ~ 30MHz)

The low frequency, which started from 9 kHz to 30MHz, was pre-scanned and the result which was 20dB lower than the limit line per 15.31(o) was not reported.

3.5.6 Test Result of Radiated Spurious at Band Edges

Please refer to Appendix B and C.

3.5.7 Duty Cycle

Please refer to Appendix D.

3.5.8 Test Result of Radiated Spurious Emission (30MHz ~ 10th Harmonic)

Please refer to Appendix B and C.



3.6 AC Conducted Emission Measurement

3.6.1 Limit of AC Conducted Emission

For equipment that is designed to be connected to the public utility (AC) power line, the radio frequency voltage that is conducted back onto the AC power line on any frequency or frequencies within the band 150 kHz to 30 MHz shall not exceed the limits in the following table.

Frequency of Emission (MHz)	Conducted Limit (dB μ V)	
	Quasi-Peak	Average
0.15-0.5	66 to 56*	56 to 46*
0.5-5	56	46
5-30	60	50

*Decreases with the logarithm of the frequency.

3.6.2 Measuring Instruments

The measuring equipment is listed in the section 4 of this test report.

3.6.3 Test Procedures

1. The EUT was placed 0.4 meter from the conducting wall of the shielding room, and it was kept at least 80 centimeters from any other grounded conducting surface.
2. Connect EUT to the power mains through a line impedance stabilization network (LISN).
3. All the support units are connecting to the other LISN.
4. The LISN provides 50 ohm coupling impedance for the measuring instrument.
5. The FCC states that a 50 ohm, 50 microhenry LISN should be used.
6. Both sides of AC line were checked for maximum conducted interference.
7. The frequency range from 150 kHz to 30 MHz was searched.
8. Set the test-receiver system to Peak Detect Function and specified bandwidth (IF bandwidth = 9kHz) with Maximum Hold Mode.

3.6.4 Test Setup

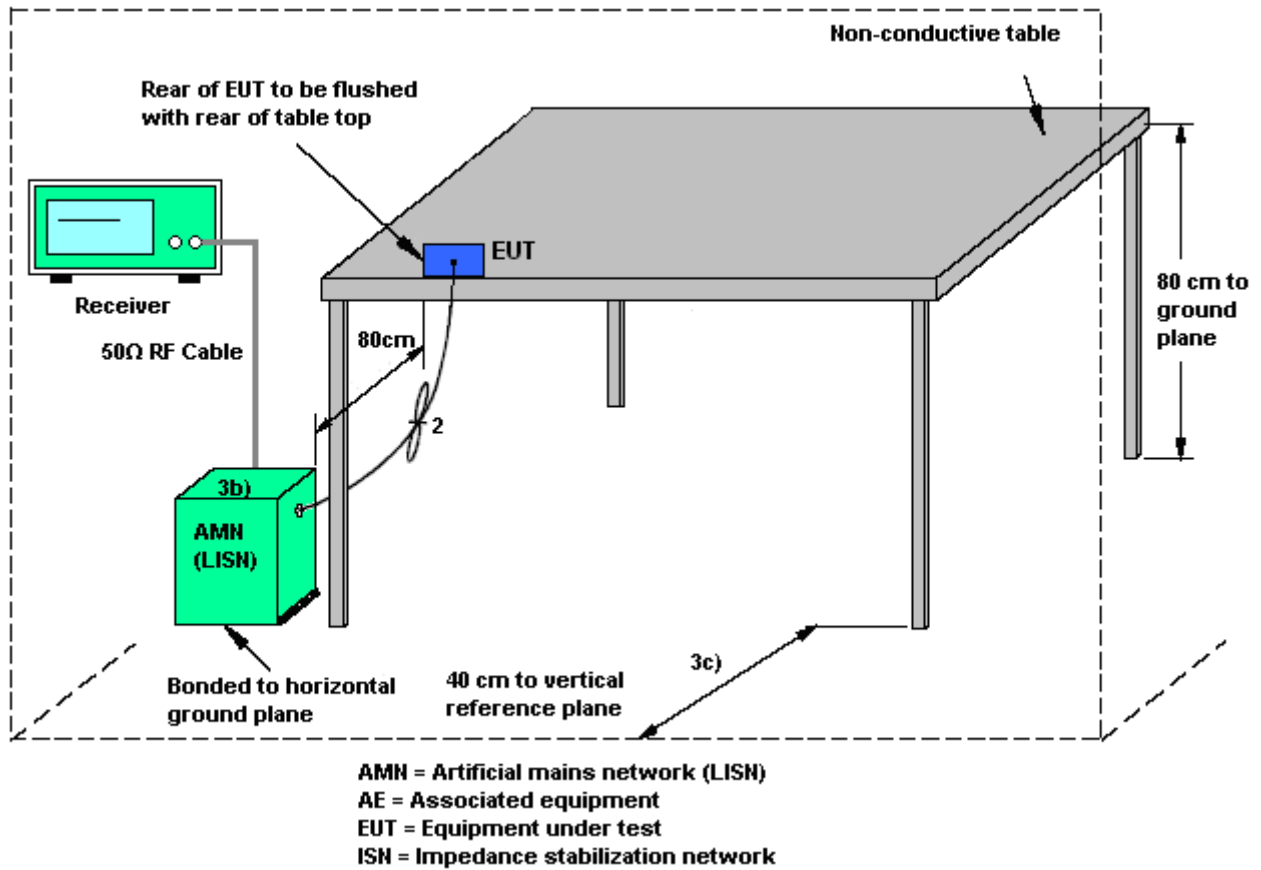

3.6.5 Test Result of AC Conducted Emission

Test Mode :	Mode 1	Temperature :	24~25°C
Test Engineer :	Kai-Chun Chu	Relative Humidity :	49~50%
Test Voltage :	120Vac / 60Hz	Phase :	Line
Function Type :	WLAN (2.4GHz) Link + Bluetooth Link + MP3 + USB Cable (Charging from Adapter)		

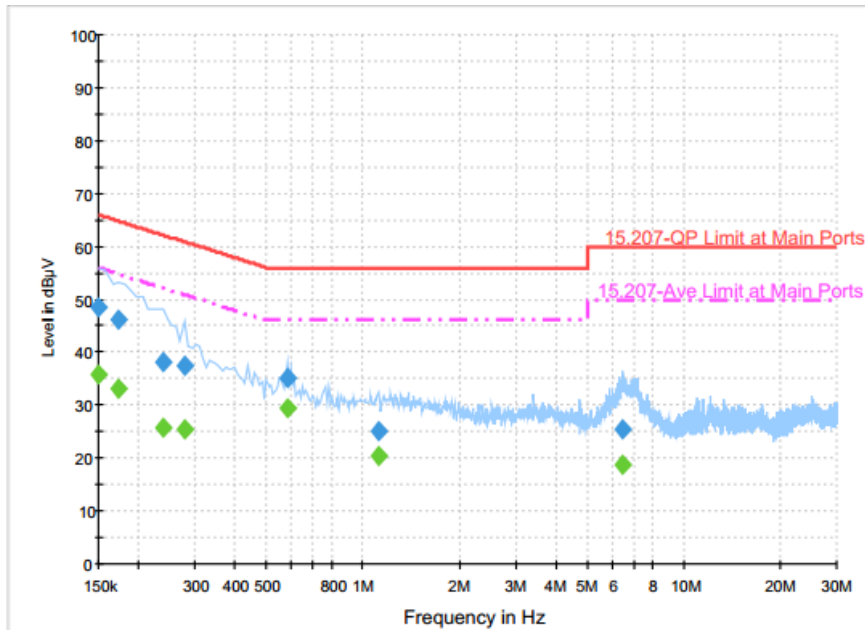

Final Result : QuasiPeak

Frequency (MHz)	QuasiPeak (dBµV)	Filter	Line	Corr. (dB)	Margin (dB)	Limit (dBµV)
0.150000	48.6	Off	L1	19.6	17.4	66.0
0.174000	46.0	Off	L1	19.6	18.8	64.8
0.238000	38.3	Off	L1	19.6	23.9	62.2
0.278000	37.6	Off	L1	19.6	23.3	60.9
0.582000	35.0	Off	L1	19.6	21.0	56.0
1.126000	25.0	Off	L1	19.7	31.0	56.0
6.478000	25.3	Off	L1	19.9	34.7	60.0

Final Result : Average

Frequency (MHz)	Average (dBµV)	Filter	Line	Corr. (dB)	Margin (dB)	Limit (dBµV)
0.150000	35.7	Off	L1	19.6	20.3	56.0
0.174000	33.0	Off	L1	19.6	21.8	54.8
0.238000	25.8	Off	L1	19.6	26.4	52.2
0.278000	25.4	Off	L1	19.6	25.5	50.9
0.582000	29.3	Off	L1	19.6	16.7	46.0
1.126000	20.4	Off	L1	19.7	25.6	46.0
6.478000	18.7	Off	L1	19.9	31.3	50.0



Test Mode :	Mode 1	Temperature :	24~25°C
Test Engineer :	Kai-Chun Chu	Relative Humidity :	49~50%
Test Voltage :	120Vac / 60Hz	Phase :	Neutral
Function Type :	WLAN (2.4GHz) Link + Bluetooth Link + MP3 + USB Cable (Charging from Adapter)		

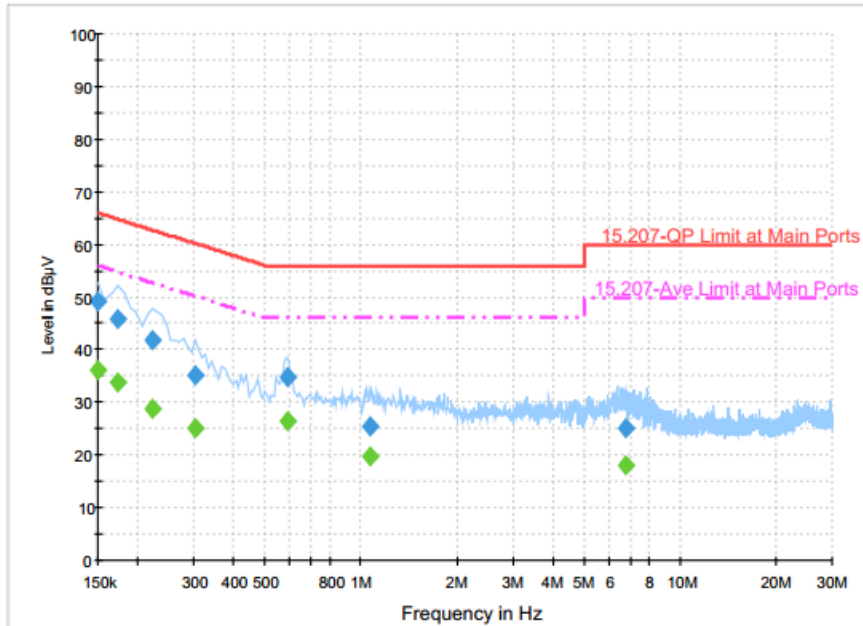

Final Result : QuasiPeak

Frequency (MHz)	QuasiPeak (dBµV)	Filter	Line	Corr. (dB)	Margin (dB)	Limit (dBµV)
0.150000	49.2	Off	N	19.6	16.8	66.0
0.174000	46.0	Off	N	19.6	18.8	64.8
0.222000	41.7	Off	N	19.6	21.0	62.7
0.302000	35.1	Off	N	19.6	25.1	60.2
0.590000	34.9	Off	N	19.6	21.1	56.0
1.070000	25.3	Off	N	19.6	30.7	56.0
6.734000	25.0	Off	N	19.9	35.0	60.0

Final Result : Average

Frequency (MHz)	Average (dBµV)	Filter	Line	Corr. (dB)	Margin (dB)	Limit (dBµV)
0.150000	36.2	Off	N	19.6	19.8	56.0
0.174000	33.8	Off	N	19.6	21.0	54.8
0.222000	28.8	Off	N	19.6	23.9	52.7
0.302000	25.2	Off	N	19.6	25.0	50.2
0.590000	26.6	Off	N	19.6	19.4	46.0
1.070000	19.8	Off	N	19.6	26.2	46.0
6.734000	18.1	Off	N	19.9	31.9	50.0



3.7 Antenna Requirements

3.7.1 Standard Applicable

If directional gain of transmitting Antennas is greater than 6dBi, the power shall be reduced by the same level in dB comparing to gain minus 6dBi. For the fixed point-to-point operation, the power shall be reduced by one dB for every 3 dB that the directional gain of the Antenna exceeds 6 dBi. The use of a permanently attached Antenna or of an Antenna that uses a unique coupling to the intentional radiator shall be considered sufficient to comply with the FCC rule.

3.7.2 Antenna Anti-Replacement Construction

An embedded-in antenna design is used.

3.7.3 Antenna Gain

The antenna peak gain of EUT is less than 6 dBi. Therefore, it is not necessary to reduce maximum peak output power limit.



4 List of Measuring Equipment

Instrument	Manufacturer	Model No.	Serial No.	Characteristics	Calibration Date	Test Date	Due Date	Remark
Power Meter	Anritsu	ML2495A	1132003	300MHz~40GHz	Aug. 12, 2015	Jun. 13, 2016 ~ Jun. 23, 2016	Aug. 11, 2016	Conducted (TH02-HY)
Power Sensor	Anritsu	MA2411B	1126017	300MHz~40GHz	Aug. 12, 2015	Jun. 13, 2016 ~ Jun. 23, 2016	Aug. 11, 2016	Conducted (TH02-HY)
Spectrum Analyzer	Rohde & Schwarz	FSP40	100057	9kHz-40GHz	Nov. 23, 2015	Jun. 13, 2016 ~ Jun. 23, 2016	Nov. 22, 2016	Conducted (TH02-HY)
AC Power Source	ChainTek	APC-1000W	N/A	N/A	N/A	Jun. 29, 2016	N/A	Conduction (CO05-HY)
EMI Test Receiver	Rohde & Schwarz	ESCI 7	100724	9kHz~7GHz	Aug. 26, 2015	Jun. 29, 2016	Aug. 25, 2016	Conduction (CO05-HY)
LISN	Rohde & Schwarz	ENV216	100080	9kHz~30MHz	Dec. 02, 2015	Jun. 29, 2016	Dec. 01, 2016	Conduction (CO05-HY)
Loop Antenna	Rohde & Schwarz	HFH2-Z2	100315	9 kHz~30 MHz	Sep. 02, 2015	Jun. 15, 2016 ~ Jun. 21, 2016	Sep. 01, 2016	Radiation (03CH13-HY)
Preamplifier	MITEQ	TTA0204	1872107	2GHz~40GHz	Feb. 15, 2016	Jun. 15, 2016 ~ Jun. 21, 2016	Feb. 14, 2017	Radiation (03CH13-HY)
Amplifier	Sonoma-Instrument	310 N	187282	10MHz~1GHz	Dec. 31, 2015	Jun. 15, 2016 ~ Jun. 21, 2016	Dec. 30, 2016	Radiation (03CH13-HY)
Bilog Antenna	TESEQ	CBL 6111D	40103	30MHz to 1GHz	Jan. 13, 2016	Jun. 15, 2016 ~ Jun. 21, 2016	Jan. 12, 2017	Radiation (03CH13-HY)
EMI Test Receiver	Keysight	N9038A(MXE)	MY55420170	N/A	Mar. 10, 2016	Jun. 15, 2016 ~ Jun. 21, 2016	Mar. 09, 2017	Radiation (03CH13-HY)
Horn Antenna	SCHWARZBECK	BBHA 9120 D	9120D-1241	1GHz ~ 18GHz	Apr. 25, 2016	Jun. 15, 2016 ~ Jun. 21, 2016	Apr. 24, 2017	Radiation (03CH13-HY)
Preamplifier	Keysight	83017A	MY53270147	1GHz~26.5GHz	Jan. 30, 2016	Jun. 15, 2016 ~ Jun. 21, 2016	Jan. 29, 2017	Radiation (03CH13-HY)
Spectrum Analyzer	Keysight	N9010A	MY55370526	N/A	Mar. 14, 2016	Jun. 15, 2016 ~ Jun. 21, 2016	Mar. 13, 2017	Radiation (03CH13-HY)
Antenna Mast	EMEC	AM-BS-4500-B	N/A	1m~4m	N/A	Jun. 15, 2016 ~ Jun. 21, 2016	N/A	Radiation (03CH13-HY)
Turn Table	EMEC	TT2000	N/A	0~360 Degree	N/A	Jun. 15, 2016 ~ Jun. 21, 2016	N/A	Radiation (03CH13-HY)
SHF-EHF Horn Antenna	SCHWARZBECK	BBHA 9170	BBHA9170584	18GHz- 40GHz	Nov. 02, 2015	Jun. 15, 2016 ~ Jun. 21, 2016	Nov. 01, 2016	Radiation (03CH13-HY)



5 Uncertainty of Evaluation

Uncertainty of Conducted Emission Measurement (150kHz ~ 30MHz)

Measuring Uncertainty for a Level of Confidence of 95% ($U = 2Uc(y)$)	2.26
---	------

Uncertainty of Radiated Emission Measurement (30 MHz ~ 1000 MHz)

Measuring Uncertainty for a Level of Confidence of 95% ($U = 2Uc(y)$)	4.70
---	------



Appendix A. Conducted Test Results

Test Engineer:	Osolemio Chang	Temperature:	21~25	°C
Test Date:	2016/6/13 ~ 2016/6/23	Relative Humidity:	51~54	%

TEST RESULTS DATA
6dB and 99% Occupied Bandwidth

2.4GHz Band										
Mod.	Data Rate	NTX	CH.	Freq. (MHz)	99% Occupied BW (MHz)		6dB BW (MHz)		6dB BW Limit (MHz)	Pass/Fail
					Ant 1	Ant 2	Ant 1	Ant 2		
11b	1Mbps	1	1	2412	13.05	13.65	9.56	10.08	0.50	Pass
11b	1Mbps	1	6	2437	12.90	14.35	10.04	10.08	0.50	Pass
11b	1Mbps	1	11	2462	13.30	14.55	10.08	10.08	0.50	Pass
11g	6Mbps	1	1	2412	17.85	17.50	15.48	15.44	0.50	Pass
11g	6Mbps	1	6	2437	18.60	18.60	15.36	15.32	0.50	Pass
11g	6Mbps	1	11	2462	17.50	17.65	15.36	15.52	0.50	Pass
HT20	MCS0	1	1	2412	18.25	18.20	15.16	15.96	0.50	Pass
HT20	MCS0	1	6	2437	18.70	19.00	15.16	15.72	0.50	Pass
HT20	MCS0	1	11	2462	18.35	18.60	15.16	15.36	0.50	Pass

TEST RESULTS DATA
Peak Output Power

2.4GHz Band																
Mod.	Data Rate	NTX	CH.	Freq. (MHz)	Peak Conducted Power (dBm)			Conducted Power Limit (dBm)		DG (dBi)		EIRP Power (dBm)		EIRP Power Limit (dBm)		Pass /Fail
					Ant 1	Ant 2	SUM	Ant 1	Ant 2	Ant 1	Ant 2	Ant 1	Ant 2	Ant 1	Ant 2	
11b	1Mbps	1	1	2412	22.91	23.85		30.00	30.00	1.47	2.36	24.38	26.21	36.00	36.00	Pass
11b	1Mbps	1	6	2437	22.92	24.01		30.00	30.00	1.47	2.36	24.39	26.37	36.00	36.00	Pass
11b	1Mbps	1	11	2462	22.66	23.84		30.00	30.00	1.47	2.36	24.13	26.20	36.00	36.00	Pass
11g	6Mbps	1	1	2412	24.65	23.88		30.00	30.00	1.47	2.36	26.12	26.24	36.00	36.00	Pass
11g	6Mbps	1	6	2437	25.56	25.24		30.00	30.00	1.47	2.36	27.03	27.60	36.00	36.00	Pass
11g	6Mbps	1	11	2462	23.90	24.17		30.00	30.00	1.47	2.36	25.37	26.53	36.00	36.00	Pass
HT20	MCS0	1	1	2412	24.49	23.81		30.00	30.00	1.47	2.36	25.96	26.17	36.00	36.00	Pass
HT20	MCS0	1	6	2437	25.51	25.26		30.00	30.00	1.47	2.36	26.98	27.62	36.00	36.00	Pass
HT20	MCS0	1	11	2462	23.62	23.94		30.00	30.00	1.47	2.36	25.09	26.30	36.00	36.00	Pass

Note: Measured power (dBm) has offset with cable loss.

TEST RESULTS DATA
Average Output Power

2.4GHz Band									
Mod.	Data Rate	N _{TX}	CH.	Freq. (MHz)	Duty Factor (dB)		Average Conducted Power (dBm)		
					Ant 1	Ant 2	Ant 1	Ant 2	SUM
11b	1Mbps	1	1	2412	0.10	0.10	20.26	21.56	
11b	1Mbps	1	6	2437	0.10	0.10	20.27	21.65	
11b	1Mbps	1	11	2462	0.10	0.10	20.18	21.55	
11g	6Mbps	1	1	2412	0.53	0.53	17.64	16.42	
11g	6Mbps	1	6	2437	0.53	0.53	19.81	19.65	
11g	6Mbps	1	11	2462	0.53	0.53	16.24	16.91	
HT20	MCS0	1	1	2412	0.63	0.56	16.85	15.51	
HT20	MCS0	1	6	2437	0.63	0.56	19.98	19.57	
HT20	MCS0	1	11	2462	0.63	0.56	15.53	16.03	

Note: Measured power (dBm) has offset with cable loss.

TEST RESULTS DATA
Peak Power Spectral Density

2.4GHz Band												
Mod.	Data Rate	NTX	CH.	Freq. (MHz)	Peak PSD (dBm/3kHz)			DG (dBi)		Peak PSD Limit (dBm/3kHz)		Pass/Fail
					Ant 1	Ant 2	Worse + 3.01	Ant 1	Ant 2	Ant 1	Ant 2	
11b	1Mbps	1	1	2412	-2.25	-1.65	-	1.47	2.36	8.00	8.00	Pass
11b	1Mbps	1	6	2437	-1.14	0.52		1.47	2.36	8.00	8.00	Pass
11b	1Mbps	1	11	2462	-3.19	-0.78		1.47	2.36	8.00	8.00	Pass
11g	6Mbps	1	1	2412	-7.41	-7.97		1.47	2.36	8.00	8.00	Pass
11g	6Mbps	1	6	2437	-4.06	-5.32		1.47	2.36	8.00	8.00	Pass
11g	6Mbps	1	11	2462	-7.69	-7.69		1.47	2.36	8.00	8.00	Pass
HT20	MCS0	1	1	2412	-6.62	-9.09		1.47	2.36	8.00	8.00	Pass
HT20	MCS0	1	6	2437	-5.90	-4.23		1.47	2.36	8.00	8.00	Pass
HT20	MCS0	1	11	2462	-10.38	-8.61		1.47	2.36	8.00	8.00	Pass

Measured power density (dBm) has offset with cable loss.



Appendix B. Radiated Spurious Emission

Test Engineer :	Bill Chang and Elvis Chen and Alex Jeng	Temperature :	20~24°C
		Relative Humidity :	45~50%

2.4GHz 2400~2483.5MHz

WiFi 802.11b (Band Edge @ 3m)

WiFi Ant. 1	Note	Frequency (MHz)	Level (dBµV/m)	Over Limit (dB)	Limit Line (dBµV/m)	Read Level (dBµV)	Antenna Factor (dB/m)	Cable Loss (dB)	Preamp Factor (dB)	Ant Pos (cm)	Table Pos (deg)	Peak Avg. (P/A)	Pol. (H/V)	
802.11b CH 01 2412MHz		2388.855	54.2	-19.8	74	51.02	27.15	7.31	31.28	371	80	P	H	
		2389.065	44.45	-9.55	54	41.27	27.15	7.31	31.28	371	80	A	H	
	*	2412	110.12	-	-	106.89	27.19	7.31	31.27	371	80	P	H	
	*	2412	107.12	-	-	103.89	27.19	7.31	31.27	371	80	A	H	
													H	
														H
			2355.78	53.28	-20.72	74	50.26	27.07	7.24	31.29	105	18	P	V
			2389.065	43.49	-10.51	54	40.31	27.15	7.31	31.28	105	18	A	V
	*		2412	105	-	-	101.77	27.19	7.31	31.27	105	18	P	V
	*		2412	101.98	-	-	98.75	27.19	7.31	31.27	105	18	A	V
														V
														V
802.11b CH 06 2437MHz		2355.24	53.28	-20.72	74	50.26	27.07	7.24	31.29	363	80	P	H	
		2385.92	42.55	-11.45	54	39.37	27.15	7.31	31.28	363	80	A	H	
	*	2437	110.34	-	-	106.96	27.28	7.36	31.26	363	80	P	H	
	*	2437	107.26	-	-	103.88	27.28	7.36	31.26	363	80	A	H	
			2490.34	53.54	-20.46	74	49.99	27.4	7.4	31.25	363	80	P	H
			2487.96	43.4	-10.6	54	39.85	27.4	7.4	31.25	363	80	A	H
			2389.43	52.47	-21.53	74	49.29	27.15	7.31	31.28	103	8	P	V
			2385.92	42.29	-11.71	54	39.11	27.15	7.31	31.28	103	8	A	V
	*		2437	107	-	-	103.62	27.28	7.36	31.26	103	8	P	V
	*		2437	104	-	-	100.62	27.28	7.36	31.26	103	8	A	V
			2488.52	54.15	-19.85	74	50.6	27.4	7.4	31.25	103	8	P	V
			2488.03	44.41	-9.59	54	40.86	27.4	7.4	31.25	103	8	A	V



802.11b CH 11 2462MHz	*	2462	111.48	-	-	108.02	27.32	7.4	31.26	400	74	P	H
	*	2462	108.38	-	-	104.92	27.32	7.4	31.26	400	74	A	H
		2483.6	56.02	-17.98	74	52.51	27.36	7.4	31.25	400	74	P	H
		2483.52	46.95	-7.05	54	43.44	27.36	7.4	31.25	400	74	A	H
													H
													H
	*	2462	108.29	-	-	104.83	27.32	7.4	31.26	100	6	P	V
	*	2462	105.16	-	-	101.7	27.32	7.4	31.26	100	6	A	V
		2483.8	55.66	-18.34	74	52.15	27.36	7.4	31.25	100	6	P	V
		2483.52	46.09	-7.91	54	42.58	27.36	7.4	31.25	100	6	A	V
													V
													V
Remark	1. No other spurious found. 2. All results are PASS against Peak and Average limit line.												



**2.4GHz 2400~2483.5MHz
WIFI 802.11b (Harmonic @ 3m)**

WIFI Ant. 1	Note	Frequency (MHz)	Level (dBμV/m)	Over Limit (dB)	Limit Line (dBμV/m)	Read Level (dBμV)	Antenna Factor (dB/m)	Cable Loss (dB)	Preamp Factor (dB)	Ant Pos (cm)	Table Pos (deg)	Peak Avg. (P/A)	Pol. (H/V)
802.11b CH 01 2412MHz		4824	45.34	-28.66	74	53.62	31.22	11.68	51.18	100	0	P	H
													H
													H
													H
		4824	46.39	-27.61	74	54.67	31.22	11.68	51.18	100	0	P	V
													V
													V
802.11b CH 06 2437MHz		4874	43.64	-30.36	74	51.95	31.31	11.53	51.15	100	0	P	H
		7311	45.71	-28.29	74	46.43	36.27	13.81	50.8	100	0	P	H
													H
													H
		4874	42.65	-31.35	74	50.96	31.31	11.53	51.15	100	0	P	V
		7311	45.73	-28.27	74	46.45	36.27	13.81	50.8	100	0	P	V
													V
802.11b CH 11 2462MHz		4924	40.76	-33.24	74	49.13	31.39	11.37	51.13	100	0	P	H
		7386	45.14	-28.86	74	45.48	36.51	13.95	50.8	100	0	P	H
													H
													H
		4924	41.22	-32.78	74	49.59	31.39	11.37	51.13	100	0	P	V
		7386	46.5	-27.5	74	46.84	36.51	13.95	50.8	100	0	P	V
													V
Remark	1. No other spurious found.												
	2. All results are PASS against Peak and Average limit line.												



**2.4GHz 2400~2483.5MHz
WIFI 802.11g (Band Edge @ 3m)**

WIFI Ant. 1	Note	Frequency (MHz)	Level (dBμV/m)	Over Limit (dB)	Limit Line (dBμV/m)	Read Level (dBμV)	Antenna Factor (dB/m)	Cable Loss (dB)	Preamp Factor (dB)	Ant Pos (cm)	Table Pos (deg)	Peak Avg. (P/A)	Pol. (H/V)	
802.11g CH 01 2412MHz		2389.38	62.93	-11.07	74	59.75	27.15	7.31	31.28	368	82	P	H	
		2390	50.09	-3.91	54	46.9	27.15	7.31	31.27	368	82	A	H	
	*	2412	110.68	-	-	107.45	27.19	7.31	31.27	368	82	P	H	
	*	2412	102.98	-	-	99.75	27.19	7.31	31.27	368	82	A	H	
													H	
													H	
			2389.905	64.23	-9.77	74	61.04	27.15	7.31	31.27	107	17	P	V
			2390	48.26	-5.74	54	45.07	27.15	7.31	31.27	107	17	A	V
	*		2412	105.46	-	-	102.23	27.19	7.31	31.27	107	17	P	V
	*		2412	97.83	-	-	94.6	27.19	7.31	31.27	107	17	A	V
													V	
													V	
802.11g CH 06 2437MHz		2384.88	54.5	-19.5	74	51.36	27.11	7.31	31.28	364	80	P	H	
		2389.04	43.51	-10.49	54	40.33	27.15	7.31	31.28	364	80	A	H	
	*	2437	112.51	-	-	109.13	27.28	7.36	31.26	364	80	P	H	
	*	2437	104.86	-	-	101.48	27.28	7.36	31.26	364	80	A	H	
			2484.6	54.26	-19.74	74	50.75	27.36	7.4	31.25	364	80	P	H
			2484.11	44.51	-9.49	54	41	27.36	7.4	31.25	364	80	A	H
			2387.09	52.95	-21.05	74	49.77	27.15	7.31	31.28	104	8	P	V
			2386.83	43.06	-10.94	54	39.88	27.15	7.31	31.28	104	8	A	V
	*		2437	108.98	-	-	105.6	27.28	7.36	31.26	104	8	P	V
	*		2437	101.36	-	-	97.98	27.28	7.36	31.26	104	8	A	V
			2488.1	55.8	-18.2	74	52.25	27.4	7.4	31.25	104	8	P	V
			2484.74	45.43	-8.57	54	41.92	27.36	7.4	31.25	104	8	A	V



802.11g CH 11 2462MHz	*	2462	110.77	-	-	107.31	27.32	7.4	31.26	400	74	P	H
	*	2462	102.54	-	-	99.08	27.32	7.4	31.26	400	74	A	H
		2483.56	67.11	-6.89	74	63.6	27.36	7.4	31.25	400	74	P	H
		2483.52	51.19	-2.81	54	47.68	27.36	7.4	31.25	400	74	A	H
													H
													H
	*	2462	107.1	-	-	103.64	27.32	7.4	31.26	100	8	P	V
	*	2462	99.38	-	-	95.92	27.32	7.4	31.26	100	8	A	V
		2483.92	65.84	-8.16	74	62.33	27.36	7.4	31.25	100	8	P	V
		2483.52	50.12	-3.88	54	46.61	27.36	7.4	31.25	100	8	A	V
													V
													V
Remark	1. No other spurious found. 2. All results are PASS against Peak and Average limit line.												



**2.4GHz 2400~2483.5MHz
WIFI 802.11g (Harmonic @ 3m)**

WIFI Ant. 1	Note	Frequency (MHz)	Level (dBμV/m)	Over Limit (dB)	Limit Line (dBμV/m)	Read Level (dBμV)	Antenna Factor (dB/m)	Cable Loss (dB)	Preamp Factor (dB)	Ant Pos (cm)	Table Pos (deg)	Peak Avg. (P/A)	Pol. (H/V)	
802.11g CH 01 2412MHz		4824	42.3	-31.7	74	50.58	31.22	11.68	51.18	100	0	P	H	
													H	
													H	
													H	
			4824	41.09	-32.91	74	49.37	31.22	11.68	51.18	100	0	P	V
														V
														V
802.11g CH 06 2437MHz		4874	40.55	-33.45	74	48.86	31.31	11.53	51.15	100	0	P	H	
		7311	45.56	-28.44	74	46.28	36.27	13.81	50.8	100	0	P	H	
													H	
													H	
			4874	40.03	-33.97	74	48.34	31.31	11.53	51.15	100	0	P	V
			7311	45.64	-28.36	74	46.36	36.27	13.81	50.8	100	0	P	V
														V
802.11g CH 11 2462MHz		4926	38.57	-35.43	74	46.94	31.39	11.37	51.13			P	H	
		7386	45.75	-28.25	74	46.09	36.51	13.95	50.8			P	H	
													H	
													H	
			4926	38.27	-35.73	74	46.64	31.39	11.37	51.13			P	V
			7386	45.79	-28.21	74	46.13	36.51	13.95	50.8			P	V
														V
Remark	1. No other spurious found.													
	2. All results are PASS against Peak and Average limit line.													



**2.4GHz 2400~2483.5MHz
WIFI 802.11n HT20 (Band Edge @ 3m)**

WIFI Ant. 1	Note	Frequency (MHz)	Level (dBμV/m)	Over Limit (dB)	Limit Line (dBμV/m)	Read Level (dBμV)	Antenna Factor (dB/m)	Cable Loss (dB)	Preamp Factor (dB)	Ant Pos (cm)	Table Pos (deg)	Peak Avg. (P/A)	Pol. (H/V)	
802.11n HT20 CH 01 2412MHz		2389.485	66.48	-7.52	74	63.3	27.15	7.31	31.28	371	82	P	H	
		2389.905	53.23	-0.77	54	50.04	27.15	7.31	31.27	371	82	A	H	
	*	2412	109.57	-	-	106.34	27.19	7.31	31.27	371	82	P	H	
	*	2412	102.21	-	-	98.98	27.19	7.31	31.27	371	82	A	H	
													H	
														H
			2390	62.38	-11.62	74	59.19	27.15	7.31	31.27	107	16	P	V
			2389.905	49.69	-4.31	54	46.5	27.15	7.31	31.27	107	16	A	V
		*	2412	104.19	-	-	100.96	27.19	7.31	31.27	107	16	P	V
		*	2412	96.86	-	-	93.63	27.19	7.31	31.27	107	16	A	V
													V	
													V	
802.11n HT20 CH 06 2437MHz		2388.78	53.07	-20.93	74	49.89	27.15	7.31	31.28	363	78	P	H	
		2388.78	44.01	-9.99	54	40.83	27.15	7.31	31.28	363	78	A	H	
	*	2437	112.1	-	-	108.72	27.28	7.36	31.26	363	78	P	H	
	*	2437	104.28	-	-	100.9	27.28	7.36	31.26	363	78	A	H	
			2491.32	55.82	-18.18	74	52.27	27.4	7.4	31.25	363	78	P	H
			2483.55	44.96	-9.04	54	41.45	27.36	7.4	31.25	363	78	A	H
			2351.99	53.1	-20.9	74	50.08	27.07	7.24	31.29	102	10	P	V
			2389.43	43.47	-10.53	54	40.29	27.15	7.31	31.28	102	10	A	V
		*	2437	108.56	-	-	105.18	27.28	7.36	31.26	102	10	P	V
		*	2437	101.12	-	-	97.74	27.28	7.36	31.26	102	10	A	V
		2492.37	56.06	-17.94	74	52.5	27.4	7.4	31.24	102	10	P	V	
		2487.19	46.07	-7.93	54	42.56	27.36	7.4	31.25	102	10	A	V	



802.11n HT20 CH 11 2462MHz	*	2462	109.38	-	-	105.92	27.32	7.4	31.26	400	73	P	H
	*	2462	101.44	-	-	97.98	27.32	7.4	31.26	400	73	A	H
		2483.52	63.92	-10.08	74	60.41	27.36	7.4	31.25	400	73	P	H
		2483.68	51.2	-2.8	54	47.69	27.36	7.4	31.25	400	73	A	H
													H
													H
	*	2462	105.92	-	-	102.46	27.32	7.4	31.26	100	8	P	V
	*	2462	98.31	-	-	94.85	27.32	7.4	31.26	100	8	A	V
		2483.8	64.48	-9.52	74	60.97	27.36	7.4	31.25	100	8	P	V
		2483.52	49.62	-4.38	54	46.11	27.36	7.4	31.25	100	8	A	V
												V	
												V	
Remark	<ol style="list-style-type: none"> No other spurious found. All results are PASS against Peak and Average limit line. 												



**2.4GHz 2400~2483.5MHz
WIFI 802.11n HT20 (Harmonic @ 3m)**

WIFI Ant. 1	Note	Frequency (MHz)	Level (dBμV/m)	Over Limit (dB)	Limit Line (dBμV/m)	Read Level (dBμV)	Antenna Factor (dB/m)	Cable Loss (dB)	Preamp Factor (dB)	Ant Pos (cm)	Table Pos (deg)	Peak Avg. (P/A)	Pol. (H/V)	
802.11n HT20 CH 01 2412MHz		4824	40.44	-33.56	74	48.72	31.22	11.68	51.18	100	0	P	H	
													H	
													H	
													H	
			4824	39.66	-34.34	74	47.94	31.22	11.68	51.18	100	0	P	V
														V
														V
802.11n HT20 CH 06 2437MHz		4874	39.98	-34.02	74	48.29	31.31	11.53	51.15	100	0	P	H	
													H	
			7311	45.46	-28.54	74	46.18	36.27	13.81	50.8	100	0	P	H
														H
			4874	40.1	-33.9	74	48.41	31.31	11.53	51.15	100	0	P	V
			7311	45.51	-28.49	74	46.23	36.27	13.81	50.8	100	0	P	V
														V
802.11n HT20 CH 11 2462MHz		4924	38.18	-35.82	74	46.55	31.39	11.37	51.13	100	0	P	H	
													H	
			7386	46.24	-27.76	74	46.58	36.51	13.95	50.8	100	0	P	H
														H
			4924	39.39	-34.61	74	47.76	31.39	11.37	51.13	100	0	P	V
			7386	45.49	-28.51	74	45.83	36.51	13.95	50.8	100	0	P	V
														V
Remark	1. No other spurious found.													
	2. All results are PASS against Peak and Average limit line.													



2.4GHz 2400~2483.5MHz

Emission below 1GHz

2.4GHz WIFI 802.11n HT20 (LF)

WIFI Ant.	Note	Frequency	Level	Over Limit	Limit Line	Read Level	Antenna Factor	Cable Loss	Preamp Factor	Ant Pos	Table Pos	Peak Avg.	Pol.	
1		(MHz)	(dBμV/m)	(dB)	(dBμV/m)	(dBμV)	(dB/m)	(dB)	(dB)	(cm)	(deg)	(P/A)	(H/V)	
2.4GHz 802.11n HT20 LF		87.24	29.16	-10.84	40	45.59	14.47	1	31.9	-	-	P	H	
		127.47	29.95	-13.55	43.5	42.99	17.64	1.19	31.87	-	-	P	H	
		257.61	36.93	-9.07	46	47.4	19.58	1.73	31.78	100	70	P	H	
		300.7	30.88	-15.12	46	41.28	19.53	1.82	31.75	-	-	P	H	
		591.9	29.45	-16.55	46	33.5	25.13	2.76	31.94	-	-	P	H	
		942.6	31.74	-14.26	46	29.54	29.94	3.44	31.18	-	-	P	H	
														H
														H
														H
														H
														H
														H
			42.15	35.22	-4.78	40	47.98	18.52	0.65	31.93	-	-	P	V
			87.51	36.26	-3.74	40	52.69	14.47	1	31.9	125	80	P	V
			158.52	35.81	-7.69	43.5	49.39	16.94	1.32	31.84	-	-	P	V
			330.8	36.83	-9.17	46	46.23	20.42	1.93	31.75	-	-	P	V
			499.5	36.71	-9.29	46	42.1	23.98	2.49	31.86	-	-	P	V
			736.8	37.87	-8.13	46	39.7	27.07	3.09	31.99	-	-	P	V
														V
														V
													V	
													V	
													V	
													V	
Remark	1. No other spurious found. 2. All results are PASS against limit line.													



2.4GHz 2400~2483.5MHz

WIFI 802.11b (Band Edge @ 3m)

WIFI	Note	Frequency	Level	Over	Limit	Read	Antenna	Cable	Preamp	Ant	Table	Peak	Pol.	
Ant.				Limit	Line	Level	Factor	Loss	Factor	Pos	Pos	Avg.		
2		(MHz)	(dBμV/m)	(dB)	(dBμV/m)	(dBμV)	(dB/m)	(dB)	(dB)	(cm)	(deg)	(P/A)	(H/V)	
802.11b CH 01 2412MHz		2390	59.54	-14.46	74	56.35	27.15	7.31	31.27	100	252	P	H	
		2389.17	53.08	-0.92	54	49.9	27.15	7.31	31.28	100	252	A	H	
	*	2412	109.63	-	-	106.4	27.19	7.31	31.27	100	252	P	H	
	*	2412	106.53	-	-	103.3	27.19	7.31	31.27	100	252	A	H	
													H	
														H
			2390	58.61	-15.39	74	55.42	27.15	7.31	31.27	104	25	P	V
			2389.275	52.76	-1.24	54	49.58	27.15	7.31	31.28	104	25	A	V
	*		2412	109.05	-	-	105.82	27.19	7.31	31.27	104	25	P	V
	*		2412	105.9	-	-	102.67	27.19	7.31	31.27	104	25	A	V
														V
														V
802.11b CH 06 2437MHz		2381.89	54.66	-19.34	74	51.52	27.11	7.31	31.28	118	270	P	H	
		2389.04	45.8	-8.2	54	42.62	27.15	7.31	31.28	118	270	A	H	
	*	2437	110.54	-	-	107.16	27.28	7.36	31.26	118	270	P	H	
	*	2437	107.36	-	-	103.98	27.28	7.36	31.26	118	270	A	H	
			2491.88	54.71	-19.29	74	51.15	27.4	7.4	31.24	118	270	P	H
			2487.89	45.27	-8.73	54	41.72	27.4	7.4	31.25	118	270	A	H
			2387.74	54.04	-19.96	74	50.86	27.15	7.31	31.28	101	24	P	V
			2389.04	44.47	-9.53	54	41.29	27.15	7.31	31.28	101	24	A	V
	*		2437	108.23	-	-	104.85	27.28	7.36	31.26	101	24	P	V
	*		2437	105.16	-	-	101.78	27.28	7.36	31.26	101	24	A	V
			2499.72	54.39	-19.61	74	50.83	27.4	7.4	31.24	101	24	P	V
			2492.3	44.83	-9.17	54	41.27	27.4	7.4	31.24	101	24	A	V



802.11b CH 11 2462MHz	*	2462	110.9	-	-	107.44	27.32	7.4	31.26	400	287	P	H
	*	2462	107.75	-	-	104.29	27.32	7.4	31.26	400	287	A	H
		2483.68	55.86	-18.14	74	52.35	27.36	7.4	31.25	400	287	P	H
		2483.52	47.15	-6.85	54	43.64	27.36	7.4	31.25	400	287	A	H
													H
													H
	*	2462	110.06	-	-	106.6	27.32	7.4	31.26	106	23	P	V
	*	2462	106.84	-	-	103.38	27.32	7.4	31.26	106	23	A	V
		2484.56	56.76	-17.24	74	53.25	27.36	7.4	31.25	106	23	P	V
		2483.56	47.36	-6.64	54	43.85	27.36	7.4	31.25	106	23	A	V
													V
													V
Remark	1. No other spurious found. 2. All results are PASS against Peak and Average limit line.												



2.4GHz 2400~2483.5MHz
WIFI 802.11b (Harmonic @ 3m)

WIFI Ant. 2	Note	Frequency (MHz)	Level (dBμV/m)	Over Limit (dB)	Limit Line (dBμV/m)	Read Level (dBμV)	Antenna Factor (dB/m)	Cable Loss (dB)	Preamp Factor (dB)	Ant Pos (cm)	Table Pos (deg)	Peak Avg. (P/A)	Pol. (H/V)	
802.11b CH 01 2412MHz		4824	44.41	-29.59	74	52.69	31.22	11.68	51.18	100	0	P	H	
													H	
													H	
													H	
			4824	44.55	-29.45	74	52.83	31.22	11.68	51.18	100	0	P	V
														V
														V
802.11b CH 06 2437MHz		4874	39.53	-34.47	74	47.84	31.31	11.53	51.15	100	0	P	H	
		7311	46.71	-27.29	74	47.43	36.27	13.81	50.8	100	0	P	H	
													H	
													H	
			4874	42.01	-31.99	74	50.32	31.31	11.53	51.15	100	0	P	V
			7311	46.53	-27.47	74	47.25	36.27	13.81	50.8	100	0	P	V
														V
802.11b CH 11 2462MHz		4924	41.3	-32.7	74	49.67	31.39	11.37	51.13	100	0	P	H	
		7386	45.8	-28.2	74	46.14	36.51	13.95	50.8	100	0	P	H	
													H	
													H	
			4924	42.7	-31.3	74	51.07	31.39	11.37	51.13	100	0	P	V
			7386	46.58	-27.42	74	46.92	36.51	13.95	50.8	100	0	P	V
														V
Remark	1. No other spurious found.													
	2. All results are PASS against Peak and Average limit line.													



**2.4GHz 2400~2483.5MHz
WIFI 802.11g (Band Edge @ 3m)**

WIFI Ant. 2	Note	Frequency (MHz)	Level (dBμV/m)	Over Limit (dB)	Limit Line (dBμV/m)	Read Level (dBμV)	Antenna Factor (dB/m)	Cable Loss (dB)	Preamp Factor (dB)	Ant Pos (cm)	Table Pos (deg)	Peak Avg. (P/A)	Pol. (H/V)	
802.11g CH 01 2412MHz		2389.59	65	-9	74	61.82	27.15	7.31	31.28	100	272	P	H	
		2390	51.34	-2.66	54	48.15	27.15	7.31	31.27	100	272	A	H	
	*	2412	106.68	-	-	103.45	27.19	7.31	31.27	100	272	P	H	
	*	2410	99.1	-	-	95.87	27.19	7.31	31.27	100	272	A	H	
													H	
														H
			2390	63.14	-10.86	74	59.95	27.15	7.31	31.27	104	8	P	V
			2390	49.96	-4.04	54	46.77	27.15	7.31	31.27	104	8	A	V
	*		2410	106.4	-	-	103.17	27.19	7.31	31.27	104	8	P	V
	*		2410	98.62	-	-	95.39	27.19	7.31	31.27	104	8	A	V
														V
														V
802.11g CH 06 2437MHz		2383.58	54.95	-19.05	74	51.81	27.11	7.31	31.28	120	251	P	H	
		2386.57	45.58	-8.42	54	42.4	27.15	7.31	31.28	120	251	A	H	
	*	2437	110.06	-	-	106.68	27.28	7.36	31.26	120	251	P	H	
	*	2437	102.74	-	-	99.36	27.28	7.36	31.26	120	251	A	H	
			2486.56	55.72	-18.28	74	52.21	27.36	7.4	31.25	120	251	P	H
			2485.65	45.54	-8.46	54	42.03	27.36	7.4	31.25	120	251	A	H
			2382.67	53.69	-20.31	74	50.55	27.11	7.31	31.28	100	22	P	V
			2386.57	44.31	-9.69	54	41.13	27.15	7.31	31.28	100	22	A	V
	*		2437	107.68	-	-	104.3	27.28	7.36	31.26	100	22	P	V
	*		2437	100.27	-	-	96.89	27.28	7.36	31.26	100	22	A	V
			2486	54.5	-19.5	74	50.99	27.36	7.4	31.25	100	22	P	V
			2484.46	45.09	-8.91	54	41.58	27.36	7.4	31.25	100	22	A	V



802.11g CH 11 2462MHz	*	2464	109.34	-	-	105.88	27.32	7.4	31.26	400	288	P	H
	*	2460	101.89	-	-	98.47	27.32	7.36	31.26	400	288	A	H
		2484.44	65.31	-8.69	74	61.8	27.36	7.4	31.25	400	288	P	H
		2483.56	52.56	-1.44	54	49.05	27.36	7.4	31.25	400	288	A	H
													H
													H
	*	2460	107.48	-	-	104.06	27.32	7.36	31.26	108	24	P	V
	*	2460	100.01	-	-	96.59	27.32	7.36	31.26	108	24	A	V
		2483.6	68.34	-5.66	74	64.83	27.36	7.4	31.25	108	24	P	V
		2483.64	51.12	-2.88	54	47.61	27.36	7.4	31.25	108	24	A	V
													V
													V
Remark	<ol style="list-style-type: none"> 1. No other spurious found. 2. All results are PASS against Peak and Average limit line. 												



**2.4GHz 2400~2483.5MHz
WIFI 802.11g (Harmonic @ 3m)**

WIFI Ant. 2	Note	Frequency (MHz)	Level (dBμV/m)	Over Limit (dB)	Limit Line (dBμV/m)	Read Level (dBμV)	Antenna Factor (dB/m)	Cable Loss (dB)	Preamp Factor (dB)	Ant Pos (cm)	Table Pos (deg)	Peak Avg. (P/A)	Pol. (H/V)	
802.11g CH 01 2412MHz		4824	38.24	-35.76	74	46.52	31.22	11.68	51.18	100	0	P	H	
													H	
													H	
													H	
			4824	38.42	-35.58	74	46.7	31.22	11.68	51.18	100	0	P	V
														V
														V
802.11g CH 06 2437MHz		4874	38.72	-35.28	74	47.03	31.31	11.53	51.15	100	0	P	H	
		7311	46.27	-27.73	74	46.99	36.27	13.81	50.8	100	0	P	H	
													H	
													H	
			4874	38.68	-35.32	74	46.99	31.31	11.53	51.15	100	0	P	V
			7311	45.49	-28.51	74	46.21	36.27	13.81	50.8	100	0	P	V
														V
802.11g CH 11 2462MHz		4924	37.91	-36.09	74	46.28	31.39	11.37	51.13	100	0	P	H	
		7386	45.44	-28.56	74	45.78	36.51	13.95	50.8	100	0	P	H	
													H	
													H	
			4924	38.54	-35.46	74	46.91	31.39	11.37	51.13	100	0	P	V
			7386	45.71	-28.29	74	46.05	36.51	13.95	50.8	100	0	P	V
														V
Remark	1. No other spurious found.													
	2. All results are PASS against Peak and Average limit line.													



**2.4GHz 2400~2483.5MHz
WIFI 802.11n HT20 (Band Edge @ 3m)**

WIFI Ant. 2	Note	Frequency (MHz)	Level (dBμV/m)	Over Limit (dB)	Limit Line (dBμV/m)	Read Level (dBμV)	Antenna Factor (dB/m)	Cable Loss (dB)	Preamp Factor (dB)	Ant Pos (cm)	Table Pos (deg)	Peak Avg. (P/A)	Pol. (H/V)	
802.11n HT20 CH 01 2412MHz		2389.905	65.51	-8.49	74	62.32	27.15	7.31	31.27	100	252	P	H	
		2390	50.09	-3.91	54	46.9	27.15	7.31	31.27	100	252	A	H	
	*	2412	105.41	-	-	102.18	27.19	7.31	31.27	100	252	P	H	
	*	2412	97.5	-	-	94.27	27.19	7.31	31.27	100	252	A	H	
													H	
														H
			2390	63.21	-10.79	74	60.02	27.15	7.31	31.27	103	6	P	V
			2389.905	49.9	-4.1	54	46.71	27.15	7.31	31.27	103	6	A	V
		*	2412	104.3	-	-	101.07	27.19	7.31	31.27	103	6	P	V
		*	2412	97.02	-	-	93.79	27.19	7.31	31.27	103	6	A	V
													V	
													V	
802.11n HT20 CH 06 2437MHz		2388.91	54.6	-19.4	74	51.42	27.15	7.31	31.28	115	251	P	H	
		2389.3	45.41	-8.59	54	42.23	27.15	7.31	31.28	115	251	A	H	
	*	2437	109.28	-	-	105.9	27.28	7.36	31.26	115	251	P	H	
	*	2437	102.15	-	-	98.77	27.28	7.36	31.26	115	251	A	H	
			2492.23	55.32	-18.68	74	51.76	27.4	7.4	31.24	115	251	P	H
			2490.55	45.58	-8.42	54	42.03	27.4	7.4	31.25	115	251	A	H
			2384.88	54.41	-19.59	74	51.27	27.11	7.31	31.28	103	24	P	V
			2388.65	44.8	-9.2	54	41.62	27.15	7.31	31.28	103	24	A	V
		*	2437	107.52	-	-	104.14	27.28	7.36	31.26	103	24	P	V
		*	2437	99.84	-	-	96.46	27.28	7.36	31.26	103	24	A	V
		2492.51	54.52	-19.48	74	50.96	27.4	7.4	31.24	103	24	P	V	
		2489.71	45.21	-8.79	54	41.66	27.4	7.4	31.25	103	24	A	V	



802.11n HT20 CH 11 2462MHz	*	2462	106.82	-	-	103.36	27.32	7.4	31.26	110	250	P	H
	*	2462	99.52	-	-	96.06	27.32	7.4	31.26	110	250	A	H
		2484.16	67.68	-6.32	74	64.17	27.36	7.4	31.25	110	250	P	H
		2483.56	53.13	-0.87	54	49.62	27.36	7.4	31.25	110	250	A	H
													H
													H
	*	2462	106.55	-	-	103.09	27.32	7.4	31.26	108	24	P	V
	*	2462	98.87	-	-	95.41	27.32	7.4	31.26	108	24	A	V
		2484.48	63.99	-10.01	74	60.48	27.36	7.4	31.25	108	24	P	V
		2483.52	51.53	-2.47	54	48.02	27.36	7.4	31.25	108	24	A	V
													V
												V	
Remark	1. No other spurious found. 2. All results are PASS against Peak and Average limit line.												



**2.4GHz 2400~2483.5MHz
WIFI 802.11n HT20 (Harmonic @ 3m)**

WIFI Ant. 2	Note	Frequency (MHz)	Level (dBμV/m)	Over Limit (dB)	Limit Line (dBμV/m)	Read Level (dBμV)	Antenna Factor (dB/m)	Cable Loss (dB)	Preamp Factor (dB)	Ant Pos (cm)	Table Pos (deg)	Peak Avg. (P/A)	Pol. (H/V)	
802.11n HT20 CH 01 2412MHz		4824	38.12	-35.88	74	46.4	31.22	11.68	51.18	100	0	P	H	
													H	
													H	
													H	
			4824	37.82	-36.18	74	46.1	31.22	11.68	51.18	100	0	P	V
														V
														V
802.11n HT20 CH 06 2437MHz		4874	37.76	-36.24	74	46.07	31.31	11.53	51.15	100	0	P	H	
		7311	45.23	-28.77	74	45.95	36.27	13.81	50.8	100	0	P	H	
													H	
													H	
			4874	37.92	-36.08	74	46.23	31.31	11.53	51.15	100	0	P	V
			7311	45.24	-28.76	74	45.96	36.27	13.81	50.8	100	0	P	V
														V
802.11n HT20 CH 11 2462MHz		4924	39.7	-34.3	74	48.07	31.39	11.37	51.13	100	0	P	H	
		7386	45.62	-28.38	74	45.96	36.51	13.95	50.8	100	0	P	H	
													H	
													H	
			4924	39.19	-34.81	74	47.56	31.39	11.37	51.13	100	0	P	V
			7386	45.18	-28.82	74	45.52	36.51	13.95	50.8	100	0	P	V
														V
Remark	1. No other spurious found.													
	2. All results are PASS against Peak and Average limit line.													



2.4GHz 2400~2483.5MHz

Emission below 1GHz

2.4GHz WIFI 802.11n HT20 (LF)

WIFI Ant.	Note	Frequency (MHz)	Level (dBμV/m)	Over Limit (dB)	Limit Line (dBμV/m)	Read Level (dBμV)	Antenna Factor (dB/m)	Cable Loss (dB)	Preamp Factor (dB)	Ant Pos (cm)	Table Pos (deg)	Peak Avg. (P/A)	Pol. (H/V)	
2.4GHz 802.11n HT20 LF		89.13	33.36	-10.14	43.5	49.56	14.69	1.01	31.9	-	-	P	H	
		127.2	31.07	-12.43	43.5	44.11	17.64	1.19	31.87	-	-	P	H	
		166.08	31.81	-11.69	43.5	46.04	16.26	1.35	31.84	-	-	P	H	
		317.5	38.97	-7.03	46	48.82	20.02	1.88	31.75	140	80	P	H	
		371.4	30.75	-15.25	46	38.89	21.52	2.1	31.76	-	-	P	H	
		911.1	31.94	-14.06	46	30.79	29.16	3.44	31.45	-	-	P	H	
														H
														H
														H
														H
														H
														H
			41.88	35.58	-4.42	40	47.79	19.08	0.64	31.93	137	60	P	V
			86.16	32.69	-7.31	40	49.24	14.36	0.99	31.9	-	-	P	V
			213.6	31.37	-12.13	43.5	45.54	16.07	1.56	31.8	-	-	P	V
			516.3	24.76	-21.24	46	29.99	24.09	2.55	31.87	-	-	P	V
			746.6	32.36	-13.64	46	33.91	27.32	3.11	31.98	-	-	P	V
			949.6	31.42	-14.58	46	29	30.1	3.44	31.12	-	-	P	V
													V	
													V	
													V	
													V	
													V	
													V	
Remark	1. No other spurious found. 2. All results are PASS against limit line.													



Note symbol

*	Fundamental Frequency which can be ignored. However, the level of any unwanted emissions shall not exceed the level of the fundamental frequency.
!	Test result is over limit line.
P/A	Peak or Average
H/V	Horizontal or Vertical



A calculation example for radiated spurious emission is shown as below:

WIFI	Note	Frequency	Level	Over	Limit	Read	Antenna	Cable	Preamp	Ant	Table	Peak	Pol.
Ant.				Limit	Line	Level	Factor	Loss	Factor	Pos	Pos	Avg.	
2		(MHz)	(dBμV/m)	(dB)	(dBμV/m)	(dBμV)	(dB/m)	(dB)	(dB)	(cm)	(deg)	(P/A)	(H/V)
802.11b		2390	55.45	-18.55	74	54.51	32.22	4.58	35.86	103	308	P	H
CH 01													
2412MHz		2390	43.54	-10.46	54	42.6	32.22	4.58	35.86	103	308	A	H

- 1. Level(dBμV/m) =
Antenna Factor(dB/m) + Cable Loss(dB) + Read Level(dBμV) - Preamp Factor(dB)
- 2. Over Limit(dB) = Level(dBμV/m) – Limit Line(dBμV/m)

For Peak Limit @ 2390MHz:

- 1. Level(dBμV/m)
= Antenna Factor(dB/m) + Cable Loss(dB) + Read Level(dBμV) - Preamp Factor(dB)
= 32.22(dB/m) + 4.58(dB) + 54.51(dBμV) – 35.86 (dB)
= 55.45 (dBμV/m)
- 2. Over Limit(dB)
= Level(dBμV/m) – Limit Line(dBμV/m)
= 55.45(dBμV/m) – 74(dBμV/m)
= -18.55(dB)

For Average Limit @ 2390MHz:

- 1. Level(dBμV/m)
= Antenna Factor(dB/m) + Cable Loss(dB) + Read Level(dBμV) - Preamp Factor(dB)
= 32.22(dB/m) + 4.58(dB) + 42.6(dBμV) – 35.86 (dB)
= 43.54 (dBμV/m)
- 2. Over Limit(dB)
= Level(dBμV/m) – Limit Line(dBμV/m)
= 43.54(dBμV/m) – 54(dBμV/m)
= -10.46(dB)

Both peak and average measured complies with the limit line, so test result is “PASS”.



Appendix C. Radiated Spurious Emission Plots

Test Engineer :	Bill Chang and Elvis Chen and Alex Jeng	Temperature :	20~24°C
		Relative Humidity :	45~50%

Note symbol

-L	Low channel location
-R	High channel location



2.4GHz 2400~2483.5MHz
WIFI 802.11b (Band Edge @ 3m)

Table with 4 columns: WIFI, ANT, 1, and two sub-columns for Horizontal and Fundamental. Rows are labeled Peak and Avg. Each cell contains a spectral plot and technical details like Site, Condition, Detector, Project, and Mode.



WIFI	2.4GHz 2400~2483.5MHz Band Edge @ 3m	
ANT	802.11b CH01 2412MHz	
1	Vertical	Fundamental
Peak	<p>Site : 03CH13-HY Condition : 15.209(PEAK) 3m HORN_91200_1241 VERTICAL RBW:1000.000kHz VBW:3000.000kHz SWT:Auto Detector : Peak Project : 631725-01 Mode : 7</p>	<p>Site : 03CH13-HY Condition : 15.209(PEAK) 3m HORN_91200_1241 VERTICAL RBW:1000.000kHz VBW:3000.000kHz SWT:Auto Detector : Peak Project : 631725-01 Mode : 7</p>
Avg.	<p>Site : 03CH13-HY Condition : 15.209(AVG) 3m HORN_91200_1241 VERTICAL RBW:1000.000kHz VBW:0.010kHz SWT:Auto Detector : Peak Project : 631725-01 Mode : 7</p>	<p>Site : 03CH13-HY Condition : 15.209(AVG) 3m HORN_91200_1241 VERTICAL RBW:1000.000kHz VBW:0.010kHz SWT:Auto Detector : Peak Project : 631725-01 Mode : 7</p>



WIFI	2.4GHz 2400~2483.5MHz Band Edge @ 3m	
ANT	802.11b CH06 2437MHz - L	
1	Horizontal	Fundamental
Peak	<p>Site : 03CH13-HY Condition : 15.209(PEAK) 3m HORN_91200_1241 HORIZONTAL RBW:1000.000kHz VBW:3000.000kHz SWT:Auto Detector : Peak Project : 631725-01 Mode : 8</p>	<p>Site : 03CH13-HY Condition : 15.209(PEAK) 3m HORN_91200_1241 HORIZONTAL RBW:1000.000kHz VBW:3000.000kHz SWT:Auto Detector : Peak Project : 631725-01 Mode : 8</p>
Avg.	<p>Site : 03CH13-HY Condition : 15.209(AVG) 3m HORN_91200_1241 HORIZONTAL RBW:1000.000kHz VBW:0.010kHz SWT:Auto Detector : Peak Project : 631725-01 Mode : 8</p>	<p>Site : 03CH13-HY Condition : 15.209(AVG) 3m HORN_91200_1241 HORIZONTAL RBW:1000.000kHz VBW:0.010kHz SWT:Auto Detector : Peak Project : 631725-01 Mode : 8</p>



WIFI	2.4GHz 2400~2483.5MHz Band Edge @ 3m	
ANT	802.11b CH06 2437MHz - R	
1	Horizontal	Fundamental
Peak	<p>Level (dBu/m) vs Frequency (MHz) plot. Date: 2016-06-15. Peak at 15.209(PK).</p> <p>Site : 03CH13-HY Condition : 15.209(PK) 3m HORN_91200_1241 HORIZONTAL RBW:1000.000KHz VBW:3000.000KHz SWT:Auto Detector : Peak Project : 631725-01 Mode : 8</p>	Left blank
Avg.	<p>Level (dBu/m) vs Frequency (MHz) plot. Date: 2016-06-15. Average at 15.209(AVG).</p> <p>Site : 03CH13-HY Condition : 15.209(AVG) 3m HORN_91200_1241 HORIZONTAL RBW:1000.000KHz VBW:0.010KHz SWT:Auto Detector : Peak Project : 631725-01 Mode : 8</p>	Left blank

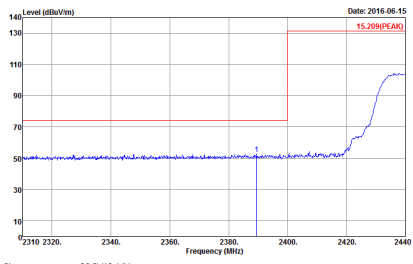
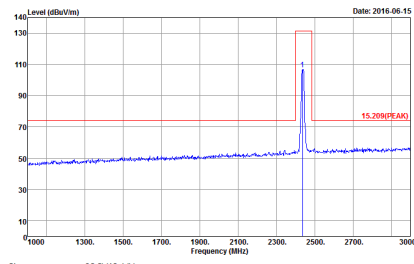
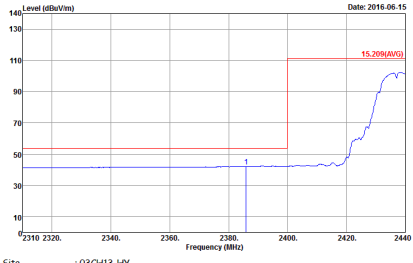
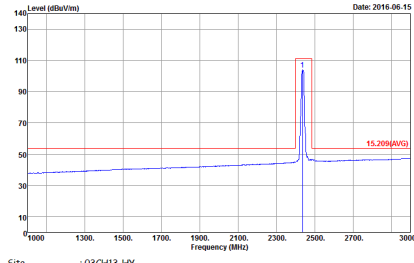

WIFI	2.4GHz 2400~2483.5MHz Band Edge @ 3m	
ANT	802.11b CH06 2437MHz - L	
1	Vertical	Fundamental
Peak	 <p>Level (dBuV/m) vs Frequency (MHz) plot for Vertical. Peak at 15.209 (PEAK). Site : 03CH13-HY Condition : 15.209 (PEAK) 3m HORN_91200_1241 VERTICAL RBW:1000.000kHz VBW:3000.000kHz SWT:Auto Detector : Peak Project : 631725-01 Mode : 8</p>	 <p>Level (dBuV/m) vs Frequency (MHz) plot for Fundamental. Peak at 15.209 (PEAK). Site : 03CH13-HY Condition : 15.209 (PEAK) 3m HORN_91200_1241 VERTICAL RBW:1000.000kHz VBW:3000.000kHz SWT:Auto Detector : Peak Project : 631725-01 Mode : 8</p>
Avg.	 <p>Level (dBuV/m) vs Frequency (MHz) plot for Vertical. Avg at 15.209 (AVG). Site : 03CH13-HY Condition : 15.209 (AVG) 3m HORN_91200_1241 VERTICAL RBW:1000.000kHz VBW:0.010kHz SWT:Auto Detector : Peak Project : 631725-01 Mode : 8</p>	 <p>Level (dBuV/m) vs Frequency (MHz) plot for Fundamental. Avg at 15.209 (AVG). Site : 03CH13-HY Condition : 15.209 (AVG) 3m HORN_91200_1241 VERTICAL RBW:1000.000kHz VBW:0.010kHz SWT:Auto Detector : Peak Project : 631725-01 Mode : 8</p>

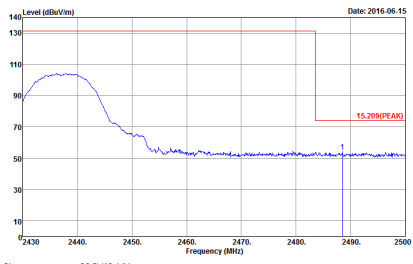
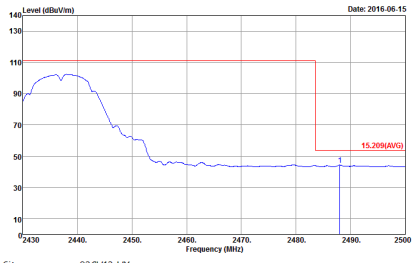

WIFI	2.4GHz 2400~2483.5MHz Band Edge @ 3m	
ANT	802.11b CH06 2437MHz - R	
1	Vertical	Fundamental
Peak	 <p>Date: 2016.06.15</p> <p>Level (dBuV/m)</p> <p>Frequency (MHz)</p> <p>Site : 03CH13-HY Condition : 15.209(Peak) 3m HORN_91200_1241 VERTICAL : RBW:1000.000KHz VBW:3000.000KHz SWT:Auto Detector : Peak Project : 631725-01 Mode : 8</p>	Left blank
Avg.	 <p>Date: 2016.06.15</p> <p>Level (dBuV/m)</p> <p>Frequency (MHz)</p> <p>Site : 03CH13-HY Condition : 15.209(AVG) 3m HORN_91200_1241 VERTICAL : RBW:1000.000KHz VBW:0.010KHz SWT:Auto Detector : Peak Project : 631725-01 Mode : 8</p>	Left blank

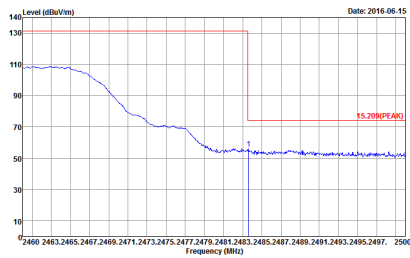
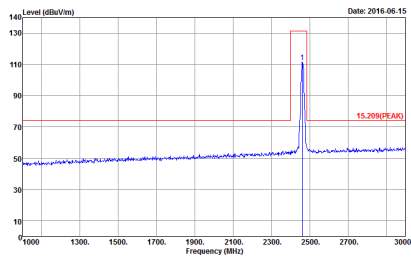
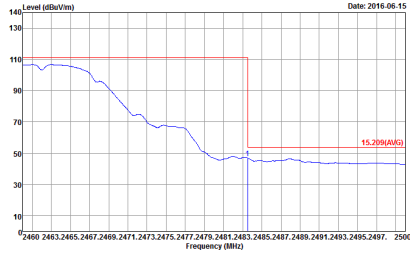
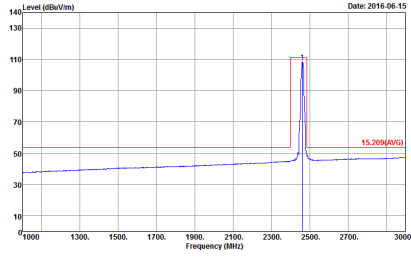

WIFI	2.4GHz 2400~2483.5MHz Band Edge @ 3m	
ANT	802.11b CH11 2462MHz	
1	Horizontal	Fundamental
Peak	 <p>Site : 03CH13-HY Condition : 15.209(PEAK) 3m HORN_91200_1241 HORIZONTAL RBW:1000.000KHz VBW:3000.000KHz SWT:Auto Detector : Peak Project : 631725-01 Mode : 9</p>	 <p>Site : 03CH13-HY Condition : 15.209(PEAK) 3m HORN_91200_1241 HORIZONTAL RBW:1000.000KHz VBW:3000.000KHz SWT:Auto Detector : Peak Project : 631725-01 Mode : 9</p>
Avg.	 <p>Site : 03CH13-HY Condition : 15.209(AVG) 3m HORN_91200_1241 HORIZONTAL RBW:1000.000KHz VBW:0.010KHz SWT:Auto Detector : Peak Project : 631725-01 Mode : 9</p>	 <p>Site : 03CH13-HY Condition : 15.209(AVG) 3m HORN_91200_1241 HORIZONTAL RBW:1000.000KHz VBW:0.010KHz SWT:Auto Detector : Peak Project : 631725-01 Mode : 9</p>

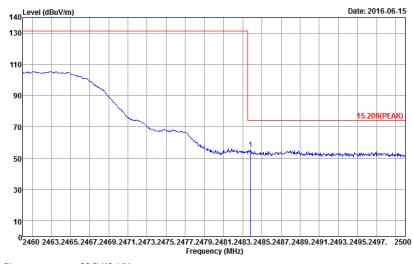
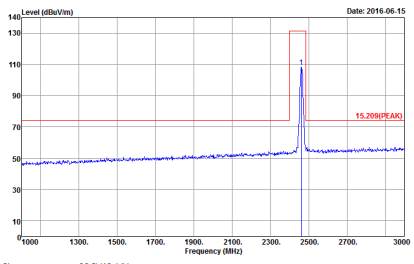
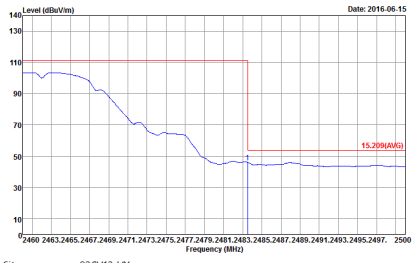
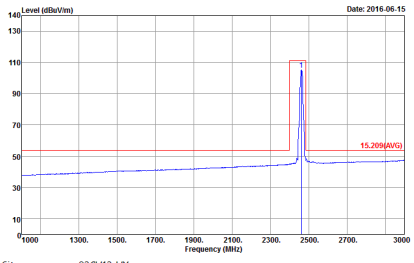

WIFI	2.4GHz 2400~2483.5MHz Band Edge @ 3m	
ANT	802.11b CH11 2462MHz	
1	Vertical	Fundamental
Peak	 <p>Site : 03CH13-HY Condition : 15.209(PEAK) 3m HORN_91200_1241 VERTICAL RBW:1000.000KHz VBW:3000.000KHz SWT:Auto Detector : Peak Project : 631725-01 Mode : 9</p>	 <p>Site : 03CH13-HY Condition : 15.209(PEAK) 3m HORN_91200_1241 VERTICAL RBW:1000.000KHz VBW:3000.000KHz SWT:Auto Detector : Peak Project : 631725-01 Mode : 9</p>
Avg.	 <p>Site : 03CH13-HY Condition : 15.209(AVG) 3m HORN_91200_1241 VERTICAL RBW:1000.000KHz VBW:0.010KHz SWT:Auto Detector : Peak Project : 631725-01 Mode : 9</p>	 <p>Site : 03CH13-HY Condition : 15.209(AVG) 3m HORN_91200_1241 VERTICAL RBW:1000.000KHz VBW:0.010KHz SWT:Auto Detector : Peak Project : 631725-01 Mode : 9</p>



2.4GHz 2400~2483.5MHz
WIFI 802.11g (Band Edge @ 3m)

Table with 4 quadrants: Peak Horizontal, Peak Fundamental, Avg. Horizontal, Avg. Fundamental. Each quadrant contains a spectral plot and technical details like Site, Condition, Detector, Project, Mode, Power.

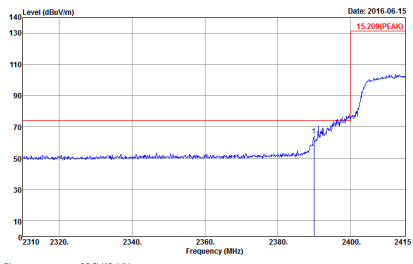
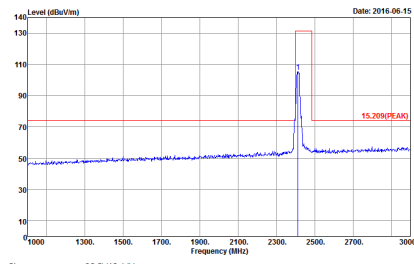
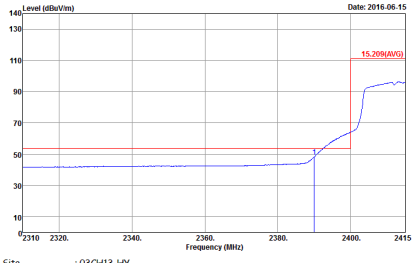
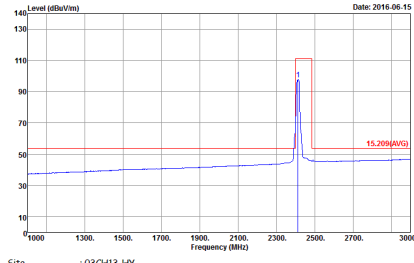

WIFI	2.4GHz 2400~2483.5MHz Band Edge @ 3m	
ANT	802.11g CH01 2412MHz	
1	Vertical	Fundamental
Peak	 <p>Level (dBuV/m) vs Frequency (MHz) plot for Vertical. Peak at 15.209 dBuV/m.</p> <p>Site : 03CH13-HY Condition : 15.209(PEAK) 3m HORN_91200_1241 VERTICAL RBW:1000.000KHz VBW:3000.000KHz SWT:Auto Detector : Peak Project : 631725-01 Mode : 10 Power : 20</p>	 <p>Level (dBuV/m) vs Frequency (MHz) plot for Fundamental. Peak at 15.209 dBuV/m.</p> <p>Site : 03CH13-HY Condition : 15.209(PEAK) 3m HORN_91200_1241 VERTICAL RBW:1000.000KHz VBW:3000.000KHz SWT:Auto Detector : Peak Project : 631725-01 Mode : 10 Power : 20</p>
Avg.	 <p>Level (dBuV/m) vs Frequency (MHz) plot for Vertical. Avg at 15.209 dBuV/m.</p> <p>Site : 03CH13-HY Condition : 15.209(AVG) 3m HORN_91200_1241 VERTICAL RBW:1000.000KHz VBW:0.300KHz SWT:Auto Detector : Peak Project : 631725-01 Mode : 10 Power : 20</p>	 <p>Level (dBuV/m) vs Frequency (MHz) plot for Fundamental. Avg at 15.209 dBuV/m.</p> <p>Site : 03CH13-HY Condition : 15.209(AVG) 3m HORN_91200_1241 VERTICAL RBW:1000.000KHz VBW:0.300KHz SWT:Auto Detector : Peak Project : 631725-01 Mode : 10 Power : 20</p>



WIFI	2.4GHz 2400~2483.5MHz Band Edge @ 3m	
ANT	802.11g CH06 2437MHz - L	
1	Horizontal	Fundamental
Peak	<p>Site : 03CH13-HY Condition : 15.209(PEAK) 3m HORN_91200_1241 HORIZONTAL RBW:1000.000KHz VBW:3000.000KHz SWT:Auto Detector : Peak Project : 631725-01 Mode : II</p>	<p>Site : 03CH13-HY Condition : 15.209(PEAK) 3m HORN_91200_1241 HORIZONTAL RBW:1000.000KHz VBW:3000.000KHz SWT:Auto Detector : Peak Project : 631725-01 Mode : II</p>
Avg.	<p>Site : 03CH13-HY Condition : 15.209(AVG) 3m HORN_91200_1241 HORIZONTAL RBW:1000.000KHz VBW:0.300KHz SWT:Auto Detector : Peak Project : 631725-01 Mode : II</p>	<p>Site : 03CH13-HY Condition : 15.209(AVG) 3m HORN_91200_1241 HORIZONTAL RBW:1000.000KHz VBW:0.300KHz SWT:Auto Detector : Peak Project : 631725-01 Mode : II</p>



WIFI	2.4GHz 2400~2483.5MHz Band Edge @ 3m	
ANT	802.11g CH06 2437MHz - R	
1	Horizontal	Fundamental
Peak	<p>Level (dBu/m) vs Frequency (MHz) plot. Date: 2016.06.15. Peak value: 15.209(PK)</p> <p>Site : 03CH13-HY Condition : 15.209(PK) 3m HORN_91200_1241 HORIZONTAL RBW:1000.000KHz VBW:3000.000KHz SWT:Auto Detector : Peak Project : 631725-01 Mode : II</p>	Left blank
Avg.	<p>Level (dBu/m) vs Frequency (MHz) plot. Date: 2016.06.15. Avg. value: 15.209(AVG)</p> <p>Site : 03CH13-HY Condition : 15.209(AVG) 3m HORN_91200_1241 HORIZONTAL RBW:1000.000KHz VBW:3000.000KHz SWT:Auto Detector : Peak Project : 631725-01 Mode : II</p>	Left blank

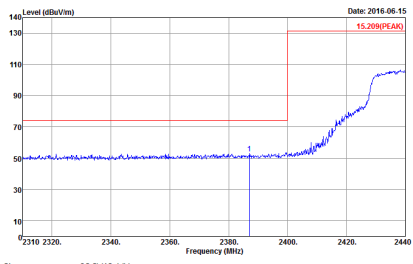
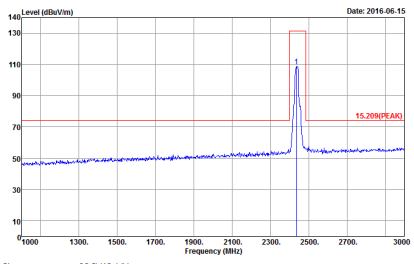
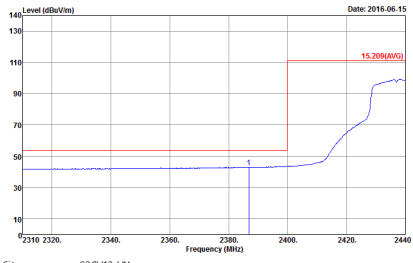
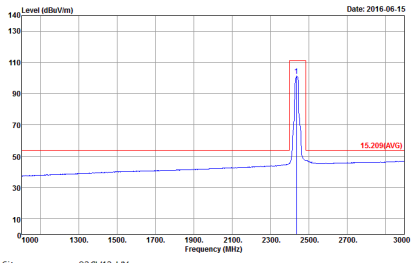

WIFI	2.4GHz 2400~2483.5MHz Band Edge @ 3m	
ANT	802.11g CH06 2437MHz - L	
1	Vertical	Fundamental
Peak	 <p>Site : 03CH13-HY Condition : 15.209(PEAK) 3m HORN_91200_1241 VERTICAL RBW:1000.000KHz VBW:3000.000KHz SWT:Auto Detector : Peak Project : 631725-01 Mode : II</p>	 <p>Site : 03CH13-HY Condition : 15.209(PEAK) 3m HORN_91200_1241 VERTICAL RBW:1000.000KHz VBW:3000.000KHz SWT:Auto Detector : Peak Project : 631725-01 Mode : II</p>
Avg.	 <p>Site : 03CH13-HY Condition : 15.209(AVG) 3m HORN_91200_1241 VERTICAL RBW:1000.000KHz VBW:0.300KHz SWT:Auto Detector : Peak Project : 631725-01 Mode : II</p>	 <p>Site : 03CH13-HY Condition : 15.209(AVG) 3m HORN_91200_1241 VERTICAL RBW:1000.000KHz VBW:0.300KHz SWT:Auto Detector : Peak Project : 631725-01 Mode : II</p>



WIFI	2.4GHz 2400~2483.5MHz Band Edge @ 3m	
ANT	802.11g CH06 2437MHz - R	
1	Vertical	Fundamental
Peak	<p>Site : 03CH13-HY Condition : 15.209(Peak) 3m HORN_91200_1241 VERTICAL RBW:1000.000KHz VBW:3000.000KHz SWT:Auto Detector : Peak Project : 631725-01 Mode : II</p>	Left Blank
Avg.	<p>Site : 03CH13-HY Condition : 15.209(AVG) 3m HORN_91200_1241 VERTICAL RBW:1000.000KHz VBW:0.300KHz SWT:Auto Detector : Peak Project : 631725-01 Mode : II</p>	Left Blank

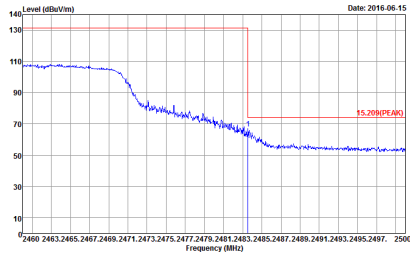
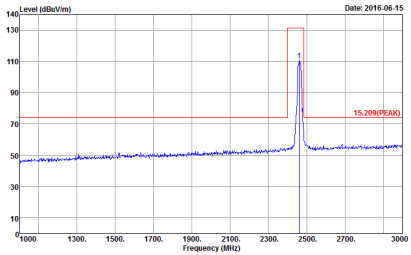
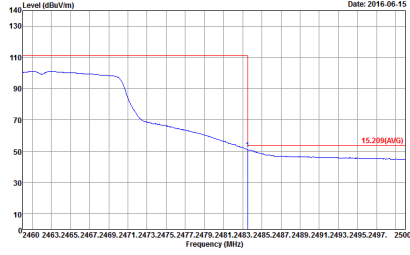
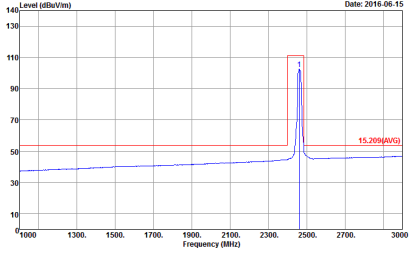

WIFI	2.4GHz 2400~2483.5MHz Band Edge @ 3m	
ANT	802.11g CH11 2462MHz	
1	Horizontal	Fundamental
Peak	 <p>Level (dBuV/m) vs Frequency (MHz) plot. The signal level is 15.209(PEAK) dBm at 2462 MHz. The plot shows a signal that starts at approximately 110 dBuV/m at 2400 MHz and drops to about 50 dBuV/m at 2462 MHz.</p> <p>Site : 03CH13-HY Condition : 15.209(PEAK) 3m HORN_91200_1241 HORIZONTAL RBW:1000.000KHz VBW:3000.000KHz SWT:Auto Detector : Peak Project : 631725-01 Mode : 12 Power : 19</p>	 <p>Level (dBuV/m) vs Frequency (MHz) plot. The signal level is 15.209(PEAK) dBm at 2462 MHz. The plot shows a sharp peak at 2462 MHz with a level of approximately 110 dBuV/m.</p> <p>Site : 03CH13-HY Condition : 15.209(PEAK) 3m HORN_91200_1241 HORIZONTAL RBW:1000.000KHz VBW:3000.000KHz SWT:Auto Detector : Peak Project : 631725-01 Mode : 12 Power : 19</p>
Avg.	 <p>Level (dBuV/m) vs Frequency (MHz) plot. The signal level is 15.209(AVG) dBm at 2462 MHz. The plot shows a signal that starts at approximately 100 dBuV/m at 2400 MHz and drops to about 50 dBuV/m at 2462 MHz.</p> <p>Site : 03CH13-HY Condition : 15.209(AVG) 3m HORN_91200_1241 HORIZONTAL RBW:1000.000KHz VBW:0.300KHz SWT:Auto Detector : Peak Project : 631725-01 Mode : 12 Power : 19</p>	 <p>Level (dBuV/m) vs Frequency (MHz) plot. The signal level is 15.209(AVG) dBm at 2462 MHz. The plot shows a sharp peak at 2462 MHz with a level of approximately 100 dBuV/m.</p> <p>Site : 03CH13-HY Condition : 15.209(AVG) 3m HORN_91200_1241 HORIZONTAL RBW:1000.000KHz VBW:0.300KHz SWT:Auto Detector : Peak Project : 631725-01 Mode : 12 Power : 19</p>

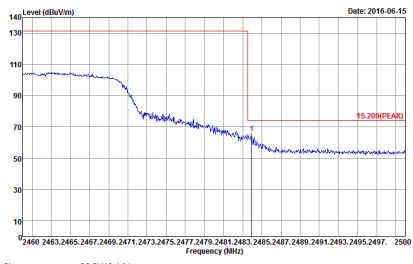
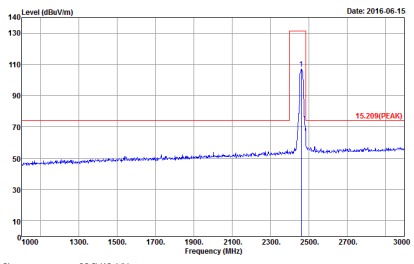
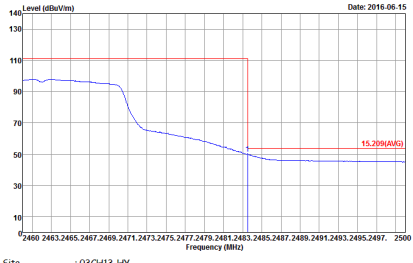
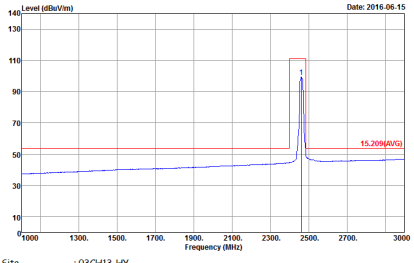

WIFI	2.4GHz 2400~2483.5MHz Band Edge @ 3m	
ANT	802.11g CH11 2462MHz	
1	Vertical	Fundamental
Peak	 <p>Site : 03CH13-HY Condition : 15.209(PEAK) 3m HORN_9120D_1241 VERTICAL RBW:1000.000KHz VBW:3000.000KHz SWT:Auto Detector : Peak Project : 631725-01 Mode : 12 Power : 19</p>	 <p>Site : 03CH13-HY Condition : 15.209(PEAK) 3m HORN_9120D_1241 VERTICAL RBW:1000.000KHz VBW:3000.000KHz SWT:Auto Detector : Peak Project : 631725-01 Mode : 12 Power : 19</p>
Avg.	 <p>Site : 03CH13-HY Condition : 15.209(AVG) 3m HORN_9120D_1241 VERTICAL RBW:1000.000KHz VBW:0.300KHz SWT:Auto Detector : Peak Project : 631725-01 Mode : 12 Power : 19</p>	 <p>Site : 03CH13-HY Condition : 15.209(AVG) 3m HORN_9120D_1241 VERTICAL RBW:1000.000KHz VBW:0.300KHz SWT:Auto Detector : Peak Project : 631725-01 Mode : 12 Power : 19</p>



2.4GHz 2400~2483.5MHz
WIFI 802.11n HT20 (Band Edge @ 3m)

Table with 4 quadrants: Peak Horizontal, Peak Fundamental, Avg. Horizontal, Avg. Fundamental. Each quadrant contains a spectral plot and technical parameters like Site, Condition, Detector, Project, Mode, Power.



WIFI	2.4GHz 2400~2483.5MHz Band Edge @ 3m	
ANT	802.11n HT20 CH01 2412MHz	
1	Vertical	Fundamental
Peak	<p>Site : 03CH13-HY Condition : 15.209(PEAK) 3m HORN_91200_1241 VERTICAL : RBW:1000.000KHz VBW:3000.000KHz SWT:Auto Detector : Peak Project : 631725-01 Mode : 13 Power : 19</p>	<p>Site : 03CH13-HY Condition : 15.209(PEAK) 3m HORN_91200_1241 VERTICAL : RBW:1000.000KHz VBW:3000.000KHz SWT:Auto Detector : Peak Project : 631725-01 Mode : 13 Power : 19</p>
Avg.	<p>Site : 03CH13-HY Condition : 15.209(AVG) 3m HORN_91200_1241 VERTICAL : RBW:1000.000KHz VBW:1.000KHz SWT:Auto Detector : Peak Project : 631725-01 Mode : 13 Power : 19</p>	<p>Site : 03CH13-HY Condition : 15.209(AVG) 3m HORN_91200_1241 VERTICAL : RBW:1000.000KHz VBW:1.000KHz SWT:Auto Detector : Peak Project : 631725-01 Mode : 13 Power : 19</p>

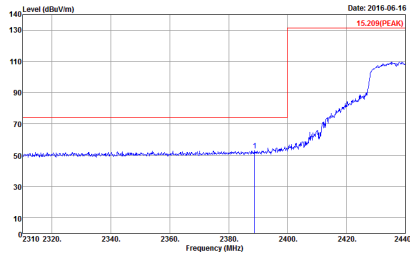
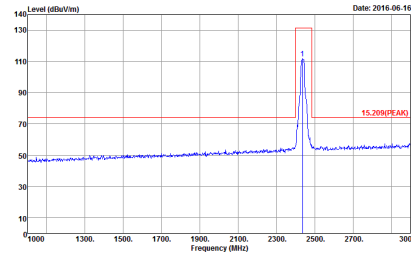
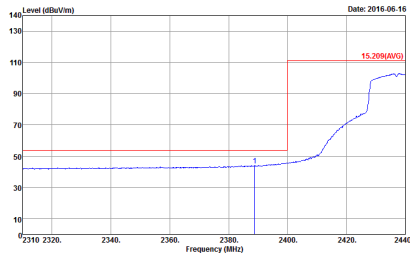
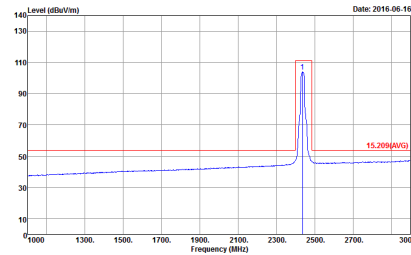

WIFI	2.4GHz 2400~2483.5MHz Band Edge @ 3m	
ANT	802.11n HT20 CH06 2437MHz - L	
1	Horizontal	Fundamental
Peak	 <p>Level (dBuV/m) vs Frequency (MHz) plot for Horizontal orientation. The y-axis ranges from 10 to 140 dBuV/m, and the x-axis ranges from 2310 to 2440 MHz. A peak is observed at 2437 MHz with a level of 15.209 dBuV/m. The plot shows a rising signal level starting around 2380 MHz.</p> <p>Site : 03CH13-HY Condition : 15.209(PEAK) 3m HORN_91200_1241 HORIZONTAL RBW:1000.000KHz VBW:3000.000KHz SWT:Auto Detector : Peak Project : 631725-01 Mode : 14</p>	 <p>Level (dBuV/m) vs Frequency (MHz) plot for Fundamental orientation. The y-axis ranges from 10 to 140 dBuV/m, and the x-axis ranges from 1000 to 3000 MHz. A sharp peak is observed at 2437 MHz with a level of 15.209 dBuV/m. The rest of the spectrum is flat at approximately 50 dBuV/m.</p> <p>Site : 03CH13-HY Condition : 15.209(PEAK) 3m HORN_91200_1241 HORIZONTAL RBW:1000.000KHz VBW:3000.000KHz SWT:Auto Detector : Peak Project : 631725-01 Mode : 14</p>
Avg.	 <p>Level (dBuV/m) vs Frequency (MHz) plot for Horizontal orientation showing the average signal. The y-axis ranges from 10 to 140 dBuV/m, and the x-axis ranges from 2310 to 2440 MHz. The peak at 2437 MHz has an average level of 15.209 dBuV/m. The signal level rises from 2380 MHz.</p> <p>Site : 03CH13-HY Condition : 15.209(AVG) 3m HORN_91200_1241 HORIZONTAL RBW:1000.000KHz VBW:1.000KHz SWT:Auto Detector : Peak Project : 631725-01 Mode : 14</p>	 <p>Level (dBuV/m) vs Frequency (MHz) plot for Fundamental orientation showing the average signal. The y-axis ranges from 10 to 140 dBuV/m, and the x-axis ranges from 1000 to 3000 MHz. The peak at 2437 MHz has an average level of 15.209 dBuV/m. The rest of the spectrum is flat at approximately 50 dBuV/m.</p> <p>Site : 03CH13-HY Condition : 15.209(AVG) 3m HORN_91200_1241 HORIZONTAL RBW:1000.000KHz VBW:1.000KHz SWT:Auto Detector : Peak Project : 631725-01 Mode : 14</p>

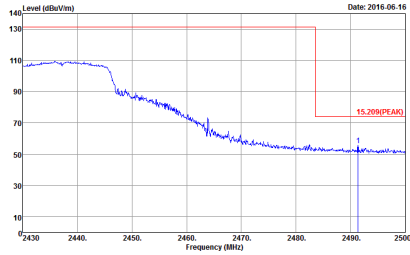
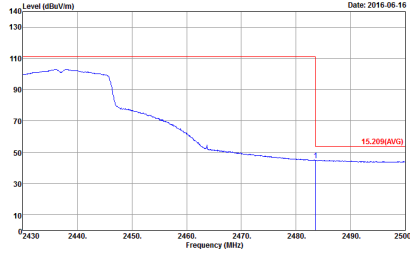

WIFI	2.4GHz 2400~2483.5MHz Band Edge @ 3m	
ANT	802.11n HT20 CH06 2437MHz - R	
1	Horizontal	Fundamental
Peak	 <p>Date: 2016-06-16</p> <p>15.209(PK)</p> <p>Site : 03CH13-HY Condition : 15.209(PK) 3m HORN_91200_1241 HORIZONTAL RBW:1000.000KHz VBW:3000.000KHz SWT:Auto Detector : Peak Project : 631725-01 Mode : 14</p>	Left blank
Avg.	 <p>Date: 2016-06-16</p> <p>15.209(AVG)</p> <p>Site : 03CH13-HY Condition : 15.209(AVG) 3m HORN_91200_1241 HORIZONTAL RBW:1000.000KHz VBW:1000KHz SWT:Auto Detector : Peak Project : 631725-01 Mode : 14</p>	Left blank

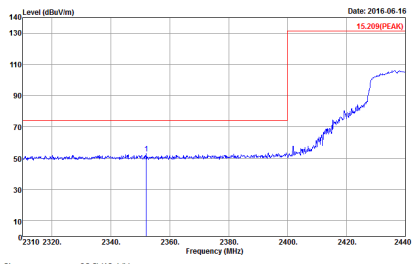
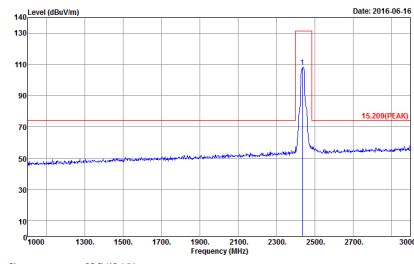
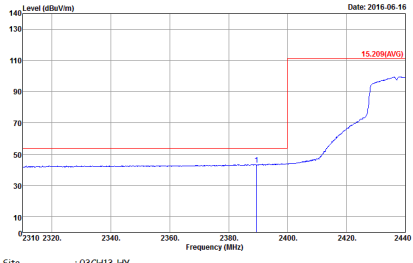
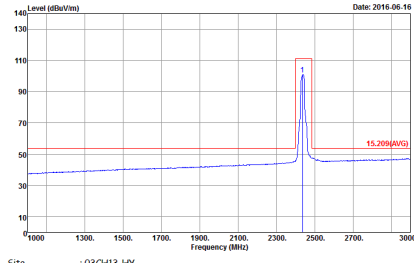

WIFI	2.4GHz 2400~2483.5MHz Band Edge @ 3m	
ANT	802.11n HT20 CH06 2437MHz - L	
1	Vertical	Fundamental
Peak	 <p>Level (dBuV/m) vs Frequency (MHz) plot for Vertical. Peak at 15.209 dBuV/m.</p> <p>Site : 03CH13-HY Condition : 15.209(PEAK) 3m HORN_91200_1241 VERTICAL RBW:1000.000KHz VBW:3000.000KHz SWT:Auto Detector : Peak Project : 631725-01 Mode : 14</p>	 <p>Level (dBuV/m) vs Frequency (MHz) plot for Fundamental. Peak at 15.209 dBuV/m.</p> <p>Site : 03CH13-HY Condition : 15.209(PEAK) 3m HORN_91200_1241 VERTICAL RBW:1000.000KHz VBW:3000.000KHz SWT:Auto Detector : Peak Project : 631725-01 Mode : 14</p>
Avg.	 <p>Level (dBuV/m) vs Frequency (MHz) plot for Vertical. Avg at 15.209 dBuV/m.</p> <p>Site : 03CH13-HY Condition : 15.209(AVG) 3m HORN_91200_1241 VERTICAL RBW:1000.000KHz VBW:1.000KHz SWT:Auto Detector : Peak Project : 631725-01 Mode : 14</p>	 <p>Level (dBuV/m) vs Frequency (MHz) plot for Fundamental. Avg at 15.209 dBuV/m.</p> <p>Site : 03CH13-HY Condition : 15.209(AVG) 3m HORN_91200_1241 VERTICAL RBW:1000.000KHz VBW:1.000KHz SWT:Auto Detector : Peak Project : 631725-01 Mode : 14</p>

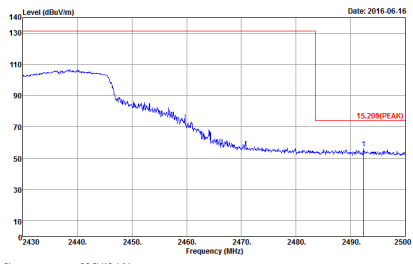
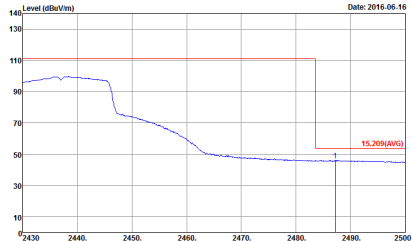

WIFI	2.4GHz 2400~2483.5MHz Band Edge @ 3m	
ANT	802.11n HT20 CH06 2437MHz - R	
1	Vertical	Fundamental
Peak	 <p>Date: 2016.06.16</p> <p>Site : 03CH13-HY Condition : 15.209(Peak) 3m HORN_91200_1241 VERTICAL : RBW:1000.000KHz VBW:3000.000KHz SWT:Auto Detector : Peak Project : 631725-01 Mode : 14</p>	Left Blank
Avg.	 <p>Date: 2016.06.16</p> <p>Site : 03CH13-HY Condition : 15.209(AVG) 3m HORN_91200_1241 VERTICAL : RBW:1000.000KHz VBW:1.000KHz SWT:Auto Detector : Peak Project : 631725-01 Mode : 14</p>	Left Blank

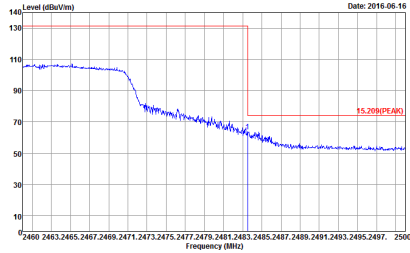
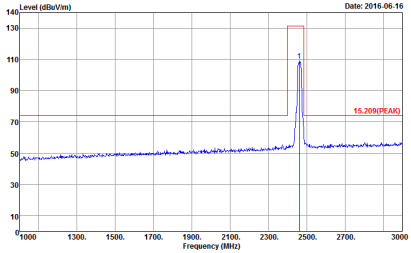
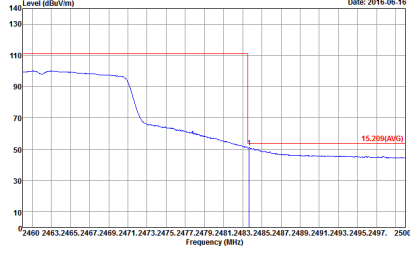
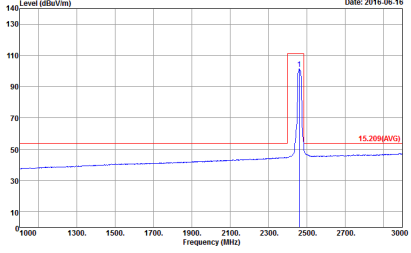

WIFI	2.4GHz 2400~2483.5MHz Band Edge @ 3m	
ANT	802.11n HT20 CH11 2462MHz	
1	Horizontal	Fundamental
Peak	 <p>Level (dBuV/m) vs Frequency (MHz) graph for Horizontal orientation. The signal level is 15.209 dBm at 2462 MHz. The graph shows a signal level of approximately 110 dBuV/m at 2400 MHz, which drops to about 70 dBuV/m at 2462 MHz, and then continues to decrease towards 2500 MHz.</p> <p>Site : 03CH13-HY Condition : 15.209(PEAK) 3m HORN_91200_1241 HORIZONTAL RBW:1000.000kHz VBW:3000.000kHz SWT:Auto Detector : Peak Project : 631725-01 Mode : 15 Power : 18</p>	 <p>Level (dBuV/m) vs Frequency (MHz) graph for Fundamental orientation. The signal level is 15.209 dBm at 2462 MHz. The graph shows a signal level of approximately 50 dBuV/m at 2400 MHz, which rises to about 110 dBuV/m at 2462 MHz, and then drops back to about 50 dBuV/m at 2500 MHz.</p> <p>Site : 03CH13-HY Condition : 15.209(PEAK) 3m HORN_91200_1241 HORIZONTAL RBW:1000.000kHz VBW:3000.000kHz SWT:Auto Detector : Peak Project : 631725-01 Mode : 15 Power : 18</p>
Avg.	 <p>Level (dBuV/m) vs Frequency (MHz) graph for Horizontal orientation. The signal level is 15.209 dBm at 2462 MHz. The graph shows a signal level of approximately 110 dBuV/m at 2400 MHz, which drops to about 70 dBuV/m at 2462 MHz, and then continues to decrease towards 2500 MHz.</p> <p>Site : 03CH13-HY Condition : 15.209(AVG) 3m HORN_91200_1241 HORIZONTAL RBW:1000.000kHz VBW:1.000kHz SWT:Auto Detector : Peak Project : 631725-01 Mode : 15 Power : 18</p>	 <p>Level (dBuV/m) vs Frequency (MHz) graph for Fundamental orientation. The signal level is 15.209 dBm at 2462 MHz. The graph shows a signal level of approximately 50 dBuV/m at 2400 MHz, which rises to about 110 dBuV/m at 2462 MHz, and then drops back to about 50 dBuV/m at 2500 MHz.</p> <p>Site : 03CH13-HY Condition : 15.209(AVG) 3m HORN_91200_1241 HORIZONTAL RBW:1000.000kHz VBW:1.000kHz SWT:Auto Detector : Peak Project : 631725-01 Mode : 15 Power : 18</p>

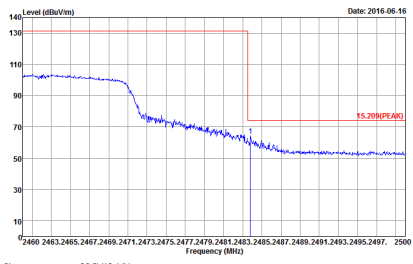
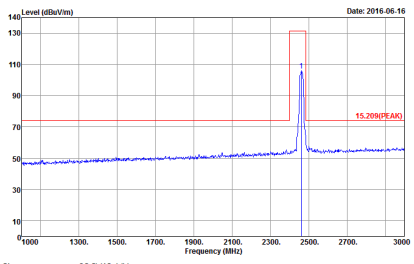
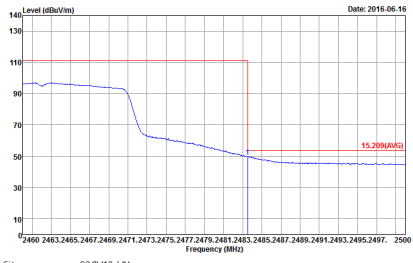
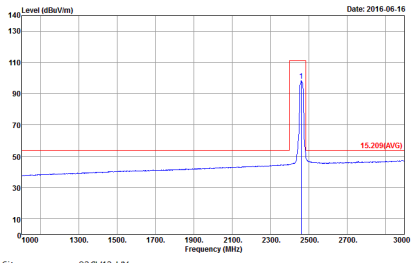

WIFI	2.4GHz 2400~2483.5MHz Fundamental @ 3m	
ANT	802.11n HT20 CH11 2462MHz	
1	Vertical	Fundamental
Peak	 <p>Site : 03CH13-HY Condition : 15.209(PEAK) 3m HORN_91200_1241 VERTICAL RBW:1000.000KHz VBW:3000.000KHz SWT:Auto Detector : Peak Project : 631725-01 Mode : 15 Power : 18</p>	 <p>Site : 03CH13-HY Condition : 15.209(PEAK) 3m HORN_91200_1241 VERTICAL RBW:1000.000KHz VBW:3000.000KHz SWT:Auto Detector : Peak Project : 631725-01 Mode : 15 Power : 18</p>
Avg.	 <p>Site : 03CH13-HY Condition : 15.209(AVG) 3m HORN_91200_1241 VERTICAL RBW:1000.000KHz VBW:1.000KHz SWT:Auto Detector : Peak Project : 631725-01 Mode : 15 Power : 18</p>	 <p>Site : 03CH13-HY Condition : 15.209(AVG) 3m HORN_91200_1241 VERTICAL RBW:1000.000KHz VBW:1.000KHz SWT:Auto Detector : Peak Project : 631725-01 Mode : 15 Power : 18</p>



**2.4GHz 2400~2483.5MHz
WIFI 802.11b (Harmonic @ 3m)**

WIFI	2.4GHz 2400~2483.5MHz Harmonic @ 3m	
ANT	802.11b CH01 2412MHz	
1	Horizontal	Vertical
Peak Avg.	<p>Site : 03CH13-HY Condition : 15.209(PEAK) 3m SHF_HORN_584 HORIZONTAL Detector : Peak Project : 631725-01 Mode : 7</p>	<p>Site : 03CH13-HY Condition : 15.209(PEAK) 3m SHF_HORN_584 VERTICAL Detector : Peak Project : 631725-01 Mode : 7</p>

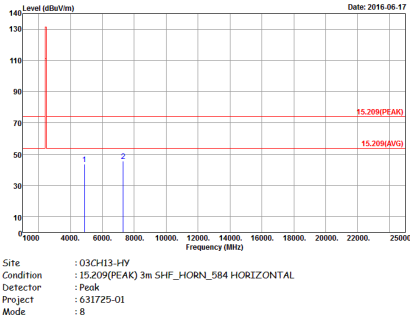
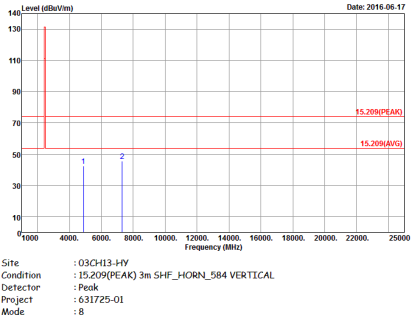

WIFI	2.4GHz 2400~2483.5MHz Harmonic @ 3m	
ANT	802.11b CH06 2437MHz	
1	Horizontal	Vertical
Peak Avg.	 <p>Site : 03CH13-#HY Condition : 15.209(Peak) 3m SHF_HORN_584 HORIZONTAL Detector : Peak Project : 631725-01 Mode : 8</p>	 <p>Site : 03CH13-#HY Condition : 15.209(Peak) 3m SHF_HORN_584 VERTICAL Detector : Peak Project : 631725-01 Mode : 8</p>

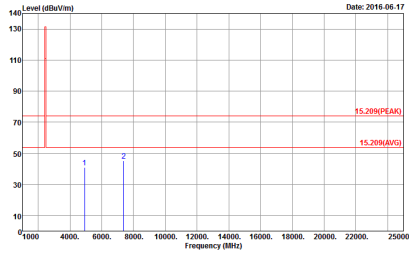
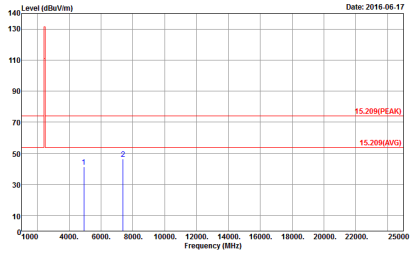

WIFI	2.4GHz 2400~2483.5MHz Harmonic @ 3m	
ANT	802.11b CH11 2462MHz	
1	Horizontal	Vertical
Peak Avg.	 <p>Site : 03CH13-HY Condition : 15.209(PEAK) 3m SHF_HORN_584 HORIZONTAL Detector : Peak Project : 631725-01 Mode : 9</p>	 <p>Site : 03CH13-HY Condition : 15.209(PEAK) 3m SHF_HORN_584 VERTICAL Detector : Peak Project : 631725-01 Mode : 9</p>



2.4GHz 2400~2483.5MHz
 WIFI 802.11g (Harmonic @ 3m)

WIFI	2.4GHz 2400~2483.5MHz Harmonic @ 3m	
ANT	802.11g CH01 2412MHz	
1	Horizontal	Vertical
Peak Avg.	<p>Date: 2016.06.17</p> <p>Site : 03CH13-4Y Condition : 15.209(PEAK) 3m SHF_HORN_584 HORIZONTAL Detector : Peak Project : 631725-01 Mode : 10</p>	<p>Date: 2016.06.17</p> <p>Site : 03CH13-4Y Condition : 15.209(PEAK) 3m SHF_HORN_584 VERTICAL Detector : Peak Project : 631725-01 Mode : 10</p>



WIFI	2.4GHz 2400~2483.5MHz Harmonic @ 3m	
ANT	802.11g CH06 2437MHz	
1	Horizontal	Vertical
Peak Avg.	<p>Site : 03CH13-4Y Condition : 15.209(PK) 3m SHF_HORN_584 HORIZONTAL Detector : Peak Project : 631725-01 Mode : II</p>	<p>Site : 03CH13-4Y Condition : 15.209(PK) 3m SHF_HORN_584 VERTICAL Detector : Peak Project : 631725-01 Mode : II</p>

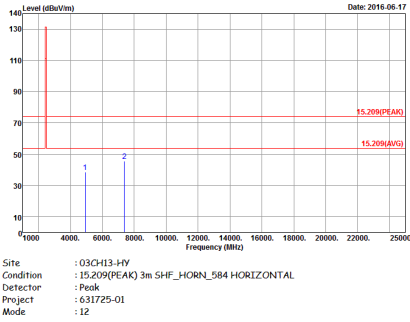
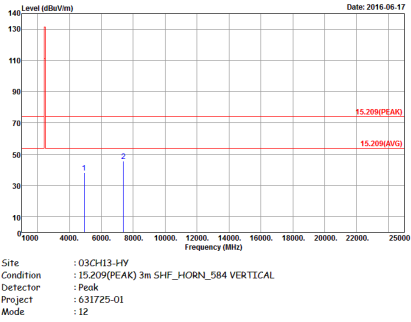

WIFI	2.4GHz 2400~2483.5MHz Harmonic @ 3m	
ANT	802.11g CH11 2462MHz	
1	Horizontal	Vertical
Peak Avg.	 <p>Site : 03CH13-#HY Condition : 15.209(Peak) 3m SHF_HORN_584 HORIZONTAL Detector : Peak Project : 631725-01 Mode : 12</p>	 <p>Site : 03CH13-#HY Condition : 15.209(Peak) 3m SHF_HORN_584 VERTICAL Detector : Peak Project : 631725-01 Mode : 12</p>



2.4GHz 2400~2483.5MHz
WIFI 802.11n HT20 (Harmonic @ 3m)

Table with 3 columns: WIFI, ANT, and antenna orientation (Horizontal/Vertical). It contains two spectral plots showing Level (dBuV/m) vs Frequency (MHz) for Peak and Avg. detection modes. Includes site and condition details for each plot.

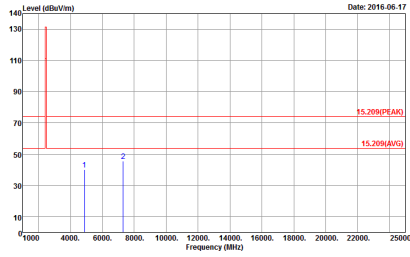
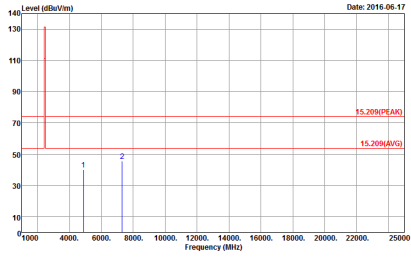

WIFI	2.4GHz 2400~2483.5MHz Harmonic @ 3m	
ANT	802.11n HT20 CH06 2437MHz	
1	Horizontal	Vertical
Peak Avg.	 <p>Site : 03CH13-#HY Condition : 15.209(Peak) 3m SHF_HORN_584 HORIZONTAL Detector : Peak Project : 631725-01 Mode : 14</p>	 <p>Site : 03CH13-#HY Condition : 15.209(Peak) 3m SHF_HORN_584 VERTICAL Detector : Peak Project : 631725-01 Mode : 14</p>

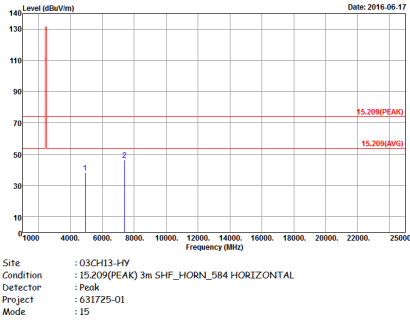
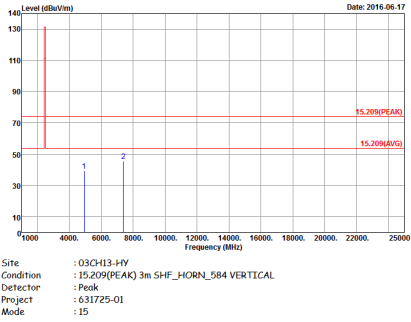

WIFI	2.4GHz 2400~2483.5MHz Harmonic @ 3m	
ANT	802.11n HT20 CH11 2462MHz	
1	Horizontal	Vertical
Peak Avg.	 <p>Site : 03CH13-#HY Condition : 15.209(Peak) 3m SHF_HORN_584 HORIZONTAL Detector : Peak Project : 631725-01 Mode : 15</p>	 <p>Site : 03CH13-#HY Condition : 15.209(Peak) 3m SHF_HORN_584 VERTICAL Detector : Peak Project : 631725-01 Mode : 15</p>



Emission below 1GHz
2.4GHz WIFI 802.11n HT20 (LF)

Table with 3 columns: WIFI (2.4GHz 2400~2483.5MHz), ANT (802.11n HT20 LF), and 1 (Horizontal/Vertical). It contains two spectral plots: Horizontal and Vertical, both showing Level (dBuV/m) vs Frequency (MHz) with a peak at 15,209 MHz. Includes site and condition details for each plot.



2.4GHz 2400~2483.5MHz
WIFI 802.11b (Band Edge @ 3m)

WIFI	2.4GHz 2400~2483.5MHz Band Edge @ 3m	
ANT	802.11b CH01 2412MHz	
2	Horizontal	Fundamental
Peak	<p>Site : 03CH13-HY Condition : 15.209(PEAK) 3m HORN_9120D_1241 HORIZONTAL Detector : Peak Project : 631725-01 Mode : 16</p>	<p>Site : 03CH13-HY Condition : 15.209(PEAK) 3m HORN_9120D_1241 HORIZONTAL Detector : Peak Project : 631725-01 Mode : 16</p>
Avg.	<p>Site : 03CH13-HY Condition : 15.209(AVG) 3m HORN_9120D_1241 HORIZONTAL Detector : Peak Project : 631725-01 Mode : 16</p>	<p>Site : 03CH13-HY Condition : 15.209(AVG) 3m HORN_9120D_1241 HORIZONTAL Detector : Peak Project : 631725-01 Mode : 16</p>

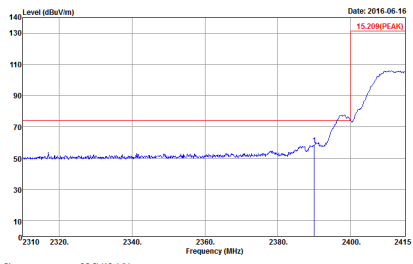
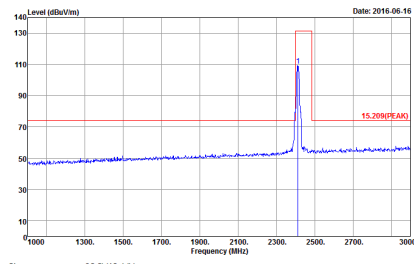
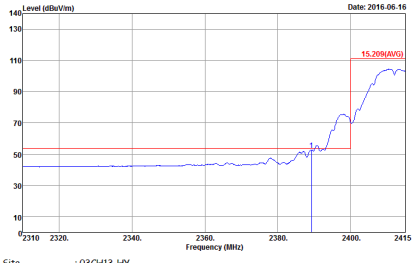
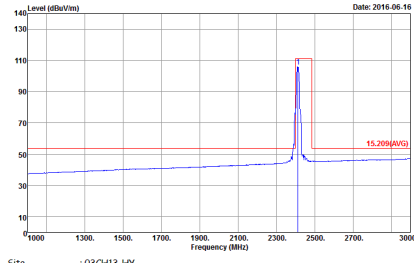

WIFI	2.4GHz 2400~2483.5MHz Band Edge @ 3m	
ANT	802.11b CH01 2412MHz	
2	Vertical	Fundamental
Peak	 <p>Site : 03CH13-HY Condition : 15.209(PEAK) 3m HORN_91200_1241 VERTICAL RBW:1000.000KHz VBW:3000.000KHz SWT:Auto Detector : Peak Project : 631725-01 Mode : 16</p>	 <p>Site : 03CH13-HY Condition : 15.209(PEAK) 3m HORN_91200_1241 VERTICAL RBW:1000.000KHz VBW:3000.000KHz SWT:Auto Detector : Peak Project : 631725-01 Mode : 16</p>
Avg.	 <p>Site : 03CH13-HY Condition : 15.209(AVG) 3m HORN_91200_1241 VERTICAL RBW:1000.000KHz VBW:0.300KHz SWT:Auto Detector : Peak Project : 631725-01 Mode : 16</p>	 <p>Site : 03CH13-HY Condition : 15.209(AVG) 3m HORN_91200_1241 VERTICAL RBW:1000.000KHz VBW:0.300KHz SWT:Auto Detector : Peak Project : 631725-01 Mode : 16</p>



WIFI	2.4GHz 2400~2483.5MHz Band Edge @ 3m	
ANT	802.11b CH06 2437MHz - L	
2	Horizontal	Fundamental
Peak	<p>Site : 03CH13-HY Condition : 15.209(PEAK) 3m HORN_91200_1241 HORIZONTAL RBW:1000.000KHz VBW:3000.000KHz SWT:Auto Detector : Peak Project : 631725-01 Mode : 17</p>	<p>Site : 03CH13-HY Condition : 15.209(PEAK) 3m HORN_91200_1241 HORIZONTAL RBW:1000.000KHz VBW:3000.000KHz SWT:Auto Detector : Peak Project : 631725-01 Mode : 17</p>
Avg.	<p>Site : 03CH13-HY Condition : 15.209(AVG) 3m HORN_91200_1241 HORIZONTAL RBW:1000.000KHz VBW:0.300KHz SWT:Auto Detector : Peak Project : 631725-01 Mode : 17</p>	<p>Site : 03CH13-HY Condition : 15.209(AVG) 3m HORN_91200_1241 HORIZONTAL RBW:1000.000KHz VBW:0.300KHz SWT:Auto Detector : Peak Project : 631725-01 Mode : 17</p>



WIFI	2.4GHz 2400~2483.5MHz Band Edge @ 3m	
ANT	802.11b CH06 2437MHz - R	
2	Horizontal	Fundamental
Peak	<p>Site : 03CH13-HY Condition : 15.209(PEAK) 3m HORN_91200_1241 HORIZONTAL RBW:1000.000KHz VBW:3000.000KHz SWT:Auto Detector : Peak Project : 631725-01 Mode : 17</p>	Left blank
Avg.	<p>Site : 03CH13-HY Condition : 15.209(AVG) 3m HORN_91200_1241 HORIZONTAL RBW:1000.000KHz VBW:3000.000KHz SWT:Auto Detector : Peak Project : 631725-01 Mode : 17</p>	Left blank

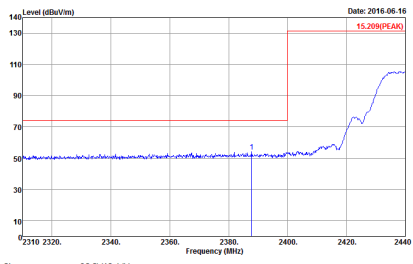
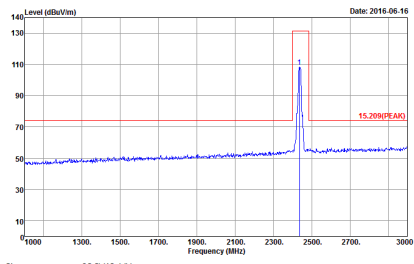
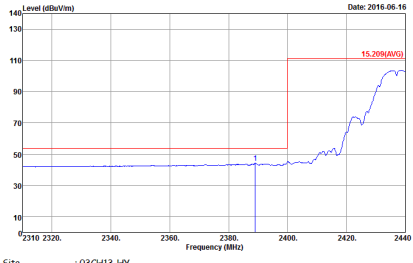
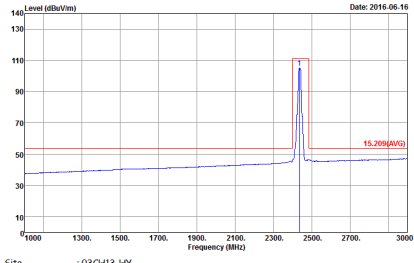

WIFI	2.4GHz 2400~2483.5MHz Band Edge @ 3m	
ANT	802.11b CH06 2437MHz - L	
2	Vertical	Fundamental
Peak	 <p>Site : 03CH13-HY Condition : 15.209(PEAK) 3m HORN_91200_1241 VERTICAL RBW:1000.000KHz VBW:3000.000KHz SWT:Auto Detector : Peak Project : 631725-01 Mode : 17</p>	 <p>Site : 03CH13-HY Condition : 15.209(PEAK) 3m HORN_91200_1241 VERTICAL RBW:1000.000KHz VBW:3000.000KHz SWT:Auto Detector : Peak Project : 631725-01 Mode : 17</p>
Avg.	 <p>Site : 03CH13-HY Condition : 15.209(AVG) 3m HORN_91200_1241 VERTICAL RBW:1000.000KHz VBW:0.300KHz SWT:Auto Detector : Peak Project : 631725-01 Mode : 17</p>	 <p>Site : 03CH13-HY Condition : 15.209(AVG) 3m HORN_91200_1241 VERTICAL RBW:1000.000KHz VBW:0.300KHz SWT:Auto Detector : Peak Project : 631725-01 Mode : 17</p>



WIFI	2.4GHz 2400~2483.5MHz Band Edge @ 3m	
ANT	802.11b CH06 2437MHz - R	
2	Vertical	Fundamental
Peak	<p>Level (dBuV/m) vs Frequency (MHz) plot. The y-axis ranges from 10 to 140 dBuV/m, and the x-axis ranges from 2430 to 2500 MHz. A blue line shows the signal level, which is high (around 110 dBuV/m) between 2430 and 2450 MHz, then drops to around 50 dBuV/m. A red vertical line marks the peak at 2483.5 MHz with a value of 15.209 dBuV/m. The plot is dated 2016.06.16.</p> <p>Site : 03CH13-HY Condition : 15.209(PEAK) 3m HORN_91200_1241 VERTICAL RBW:1000.000KHz VBW:3000.000KHz SWT:Auto Detector : Peak Project : 631725-01 Mode : 17</p>	Left blank
Avg.	<p>Level (dBuV/m) vs Frequency (MHz) plot. The y-axis ranges from 10 to 140 dBuV/m, and the x-axis ranges from 2430 to 2500 MHz. A blue line shows the signal level, which is high (around 110 dBuV/m) between 2430 and 2450 MHz, then drops to around 50 dBuV/m. A red vertical line marks the average level at 2483.5 MHz with a value of 15.209 dBuV/m. The plot is dated 2016.06.16.</p> <p>Site : 03CH13-HY Condition : 15.209(AVG) 3m HORN_91200_1241 VERTICAL RBW:1000.000KHz VBW:0.300KHz SWT:Auto Detector : Peak Project : 631725-01 Mode : 17</p>	Left blank

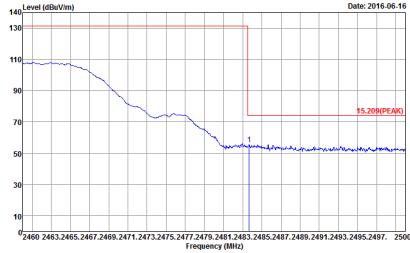
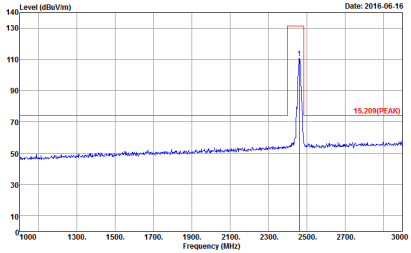
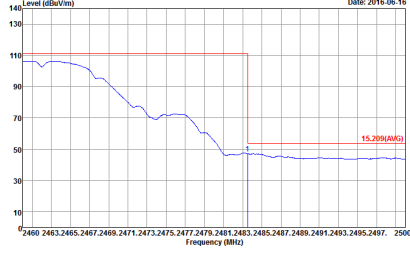
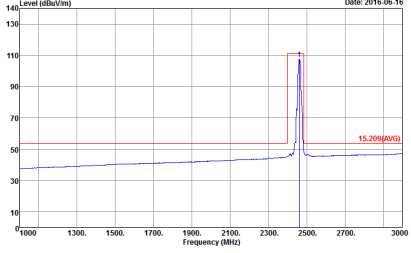

WIFI	2.4GHz 2400~2483.5MHz Band Edge @ 3m	
ANT	802.11b CH11 2462MHz	
2	Horizontal	Fundamental
Peak	 <p>Site : 03CH13-HY Condition : 15.209(PEAK) 3m HORN_91200_1241 HORIZONTAL RBW:1000.000KHz VBW:3000.000KHz SWT:Auto Detector : Peak Project : 631725-01 Mode : 1B</p>	 <p>Site : 03CH13-HY Condition : 15.209(PEAK) 3m HORN_91200_1241 HORIZONTAL RBW:1000.000KHz VBW:3000.000KHz SWT:Auto Detector : Peak Project : 631725-01 Mode : 1B</p>
Avg.	 <p>Site : 03CH13-HY Condition : 15.209(AVG) 3m HORN_91200_1241 HORIZONTAL RBW:1000.000KHz VBW:0.300KHz SWT:Auto Detector : Peak Project : 631725-01 Mode : 1B</p>	 <p>Site : 03CH13-HY Condition : 15.209(AVG) 3m HORN_91200_1241 HORIZONTAL RBW:1000.000KHz VBW:0.300KHz SWT:Auto Detector : Peak Project : 631725-01 Mode : 1B</p>

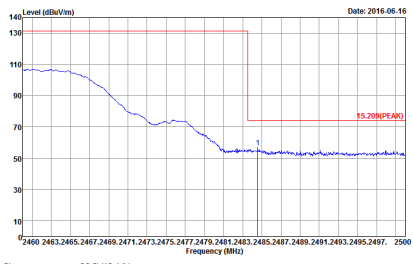
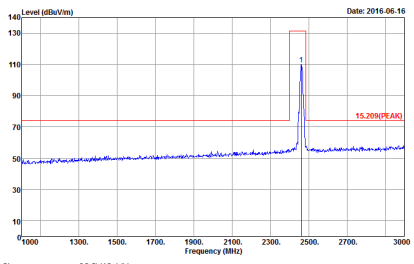
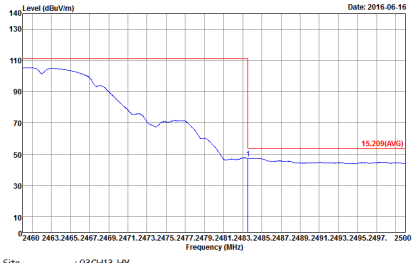
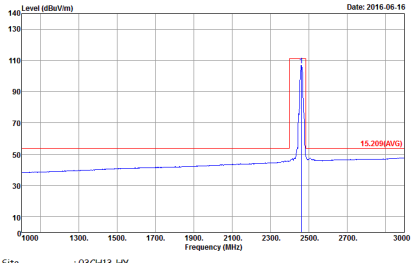

WIFI	2.4GHz 2400~2483.5MHz Band Edge @ 3m	
ANT	802.11b CH11 2462MHz	
2	Vertical	Fundamental
Peak	 <p>Level (dBuV/m) vs Frequency (MHz) plot for Vertical Peak. The plot shows a signal level starting at approximately 110 dBuV/m at 2400 MHz and decreasing to about 50 dBuV/m at 2483.5 MHz. A red box highlights a peak at 2462 MHz with a value of 15.209(PEAK).</p> <p>Site : 03CH13-HY Condition : 15.209(PEAK) 3m HORN_91200_1241 VERTICAL RBW:1000.000KHz VBW:3000.000KHz SWT:Auto Detector : Peak Project : 631725-01 Mode : 1B</p>	 <p>Level (dBuV/m) vs Frequency (MHz) plot for Fundamental Peak. The plot shows a sharp peak at 2462 MHz with a value of 15.209(PEAK) against a noise floor of approximately 50 dBuV/m.</p> <p>Site : 03CH13-HY Condition : 15.209(PEAK) 3m HORN_91200_1241 VERTICAL RBW:1000.000KHz VBW:3000.000KHz SWT:Auto Detector : Peak Project : 631725-01 Mode : 1B</p>
Avg.	 <p>Level (dBuV/m) vs Frequency (MHz) plot for Vertical Average. The plot shows a signal level starting at approximately 110 dBuV/m at 2400 MHz and decreasing to about 50 dBuV/m at 2483.5 MHz. A red box highlights a peak at 2462 MHz with a value of 15.209(AVG).</p> <p>Site : 03CH13-HY Condition : 15.209(AVG) 3m HORN_91200_1241 VERTICAL RBW:1000.000KHz VBW:0.300KHz SWT:Auto Detector : Peak Project : 631725-01 Mode : 1B</p>	 <p>Level (dBuV/m) vs Frequency (MHz) plot for Fundamental Average. The plot shows a sharp peak at 2462 MHz with a value of 15.209(AVG) against a noise floor of approximately 50 dBuV/m.</p> <p>Site : 03CH13-HY Condition : 15.209(AVG) 3m HORN_91200_1241 VERTICAL RBW:1000.000KHz VBW:0.300KHz SWT:Auto Detector : Peak Project : 631725-01 Mode : 1B</p>

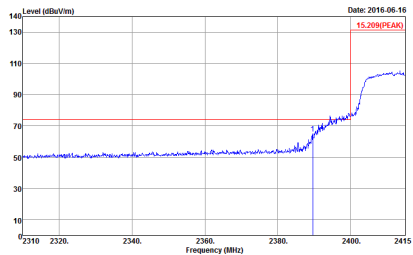
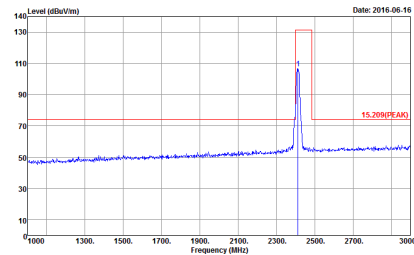
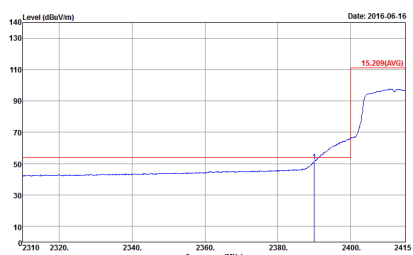
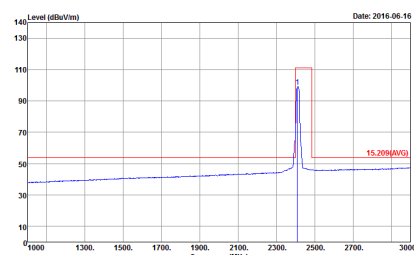

2.4GHz 2400~2483.5MHz
WIFI 802.11g (Band Edge @ 3m)

WIFI	2.4GHz 2400~2483.5MHz Band Edge @ 3m	
ANT	802.11g CH01 2412MHz	
2	Horizontal	Fundamental
Peak	 <p>Site : 03CH13-HY Condition : 15.209(PEAK) 3m HORN_9120D_1241 HORIZONTAL Detector : RBW:1000.000KHz VBW:3000.000KHz SWT:Auto Project : 631725-01 Mode : 19 power setting : 19</p>	 <p>Site : 03CH13-HY Condition : 15.209(PEAK) 3m HORN_9120D_1241 HORIZONTAL Detector : RBW:1000.000KHz VBW:3000.000KHz SWT:Auto Project : 631725-01 Mode : 19 power setting : 19</p>
Avg.	 <p>Site : 03CH13-HY Condition : 15.209(AVG) 3m HORN_9120D_1241 HORIZONTAL Detector : Peak Project : 631725-01 Mode : 19 power setting : 19</p>	 <p>Site : 03CH13-HY Condition : 15.209(AVG) 3m HORN_9120D_1241 HORIZONTAL Detector : Peak Project : 631725-01 Mode : 19 power setting : 19</p>

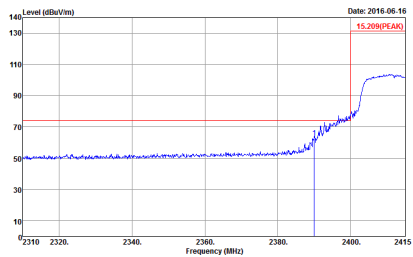
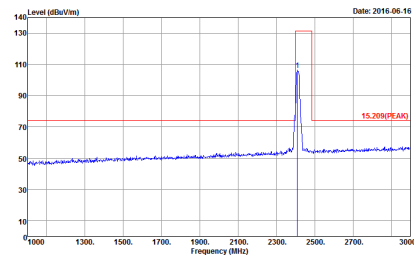
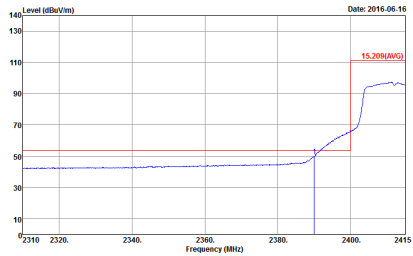
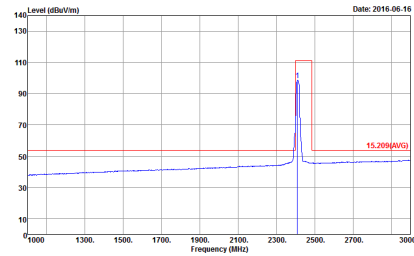

WIFI	2.4GHz 2400~2483.5MHz Band Edge @ 3m	
ANT	802.11g CH01 2412MHz	
2	Vertical	Fundamental
Peak	 <p>Level (dBuV/m) vs Frequency (MHz) plot for Vertical. Peak at 15.209 dBuV/m.</p> <p>Site : 03CH13-HY Condition : 15.209(PEAK) 3m HORN_9120D_1241 VERTICAL RBW:1000.000KHz VBW:3000.000KHz SWT:Auto Detector : Peak Project : 631725-01 Mode : 19 power setting : 19</p>	 <p>Level (dBuV/m) vs Frequency (MHz) plot for Fundamental. Peak at 15.209 dBuV/m.</p> <p>Site : 03CH13-HY Condition : 15.209(PEAK) 3m HORN_9120D_1241 VERTICAL RBW:1000.000KHz VBW:3000.000KHz SWT:Auto Detector : Peak Project : 631725-01 Mode : 19 power setting : 19</p>
Avg.	 <p>Level (dBuV/m) vs Frequency (MHz) plot for Vertical. Avg at 15.209 dBuV/m.</p> <p>Site : 03CH13-HY Condition : 15.209(AVG) 3m HORN_9120D_1241 VERTICAL RBW:1000.000KHz VBW:1.000KHz SWT:Auto Detector : Peak Project : 631725-01 Mode : 19 power setting : 19</p>	 <p>Level (dBuV/m) vs Frequency (MHz) plot for Fundamental. Avg at 15.209 dBuV/m.</p> <p>Site : 03CH13-HY Condition : 15.209(AVG) 3m HORN_9120D_1241 VERTICAL RBW:1000.000KHz VBW:1.000KHz SWT:Auto Detector : Peak Project : 631725-01 Mode : 19 power setting : 19</p>



WIFI	2.4GHz 2400~2483.5MHz Band Edge @ 3m	
ANT	802.11g CH06 2437MHz - L	
2	Horizontal	Fundamental
Peak	<p>Site : 03CH13-HY Condition : 15.209(PEAK) 3m HORN_91200_1241 HORIZONTAL RBW:1000.000KHz VBW:3000.000KHz SWT:Auto Detector : Peak Project : 631725-01 Mode : 20</p>	<p>Site : 03CH13-HY Condition : 15.209(PEAK) 3m HORN_91200_1241 HORIZONTAL RBW:1000.000KHz VBW:3000.000KHz SWT:Auto Detector : Peak Project : 631725-01 Mode : 20</p>
Avg.	<p>Site : 03CH13-HY Condition : 15.209(AVG) 3m HORN_91200_1241 HORIZONTAL RBW:1000.000KHz VBW:1.000KHz SWT:Auto Detector : Peak Project : 631725-01 Mode : 20</p>	<p>Site : 03CH13-HY Condition : 15.209(AVG) 3m HORN_91200_1241 HORIZONTAL RBW:1000.000KHz VBW:1.000KHz SWT:Auto Detector : Peak Project : 631725-01 Mode : 20</p>

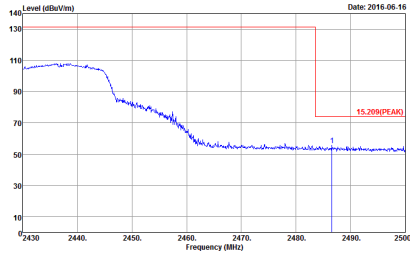
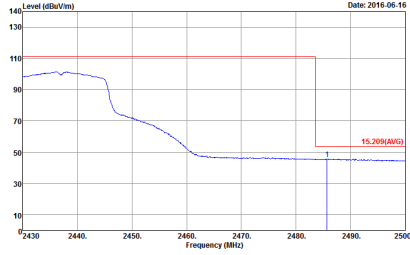

WIFI	2.4GHz 2400~2483.5MHz Band Edge @ 3m	
ANT	802.11g CH06 2437MHz - R	
2	Horizontal	Fundamental
Peak	 <p> Site : 03CH13-HY Condition : 15.209(PK) 3m HORN_91200_1241 HORIZONTAL RBW:1000.000KHz VBW:3000.000KHz SWT:Auto Detector : Peak Project : 631725-01 Mode : 20 </p>	Left blank
Avg.	 <p> Site : 03CH13-HY Condition : 15.209(AVG) 3m HORN_91200_1241 HORIZONTAL RBW:1000.000KHz VBW:1.000KHz SWT:Auto Detector : Peak Project : 631725-01 Mode : 20 </p>	Left blank

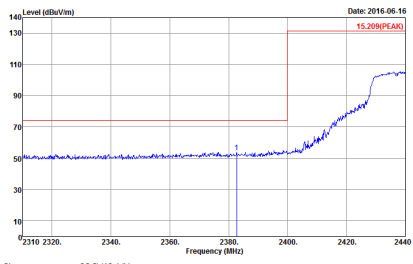
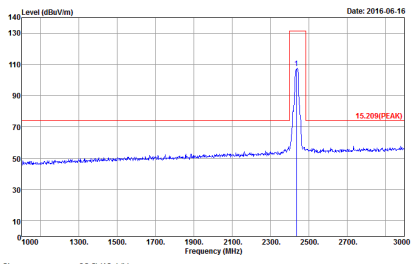
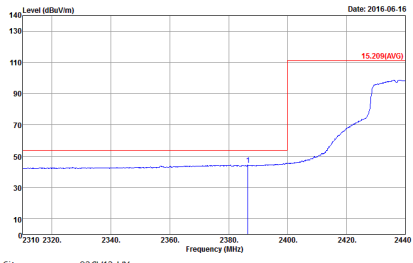
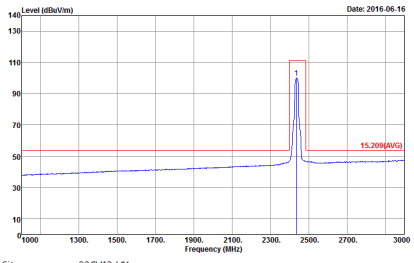

WIFI	2.4GHz 2400~2483.5MHz Band Edge @ 3m	
ANT	802.11g CH06 2437MHz - L	
2	Vertical	Fundamental
Peak	 <p>Site : 03CH13-HY Condition : 15.209(PEAK) 3m HORN_91200_1241 VERTICAL RBW:1000.000kHz VBW:3000.000kHz SWT:Auto Detector : Peak Project : 631725-01 Mode : Z0</p>	 <p>Site : 03CH13-HY Condition : 15.209(PEAK) 3m HORN_91200_1241 VERTICAL RBW:1000.000kHz VBW:3000.000kHz SWT:Auto Detector : Peak Project : 631725-01 Mode : Z0</p>
Avg.	 <p>Site : 03CH13-HY Condition : 15.209(AVG) 3m HORN_91200_1241 VERTICAL RBW:1000.000kHz VBW:1.000kHz SWT:Auto Detector : Peak Project : 631725-01 Mode : Z0</p>	 <p>Site : 03CH13-HY Condition : 15.209(AVG) 3m HORN_91200_1241 VERTICAL RBW:1000.000kHz VBW:1.000kHz SWT:Auto Detector : Peak Project : 631725-01 Mode : Z0</p>

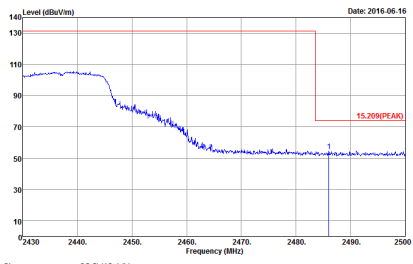
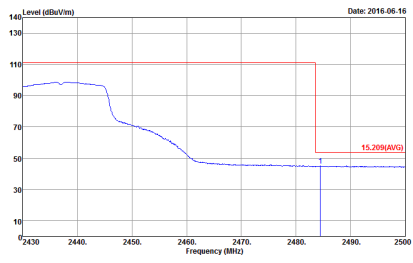

WIFI	2.4GHz 2400~2483.5MHz Band Edge @ 3m	
ANT	802.11g CH06 2437MHz - R	
2	Vertical	Fundamental
Peak	 <p>Date: 2016.06.16</p> <p>Level (dBu/m)</p> <p>Frequency (MHz)</p> <p>15.209(PEAK)</p> <p>Site : 03CH13-HY Condition : 15.209(PEAK) 3m HORN_91200_1241 VERTICAL : RBW:1000.000KHz VBW:3000.000KHz SWT:Auto Detector : Peak Project : 631725-01 Mode : 20</p>	Left Blank
Avg.	 <p>Date: 2016.06.16</p> <p>Level (dBu/m)</p> <p>Frequency (MHz)</p> <p>15.209(AVG)</p> <p>Site : 03CH13-HY Condition : 15.209(AVG) 3m HORN_91200_1241 VERTICAL : RBW:1000.000KHz VBW:1.000KHz SWT:Auto Detector : Peak Project : 631725-01 Mode : 20</p>	Left Blank

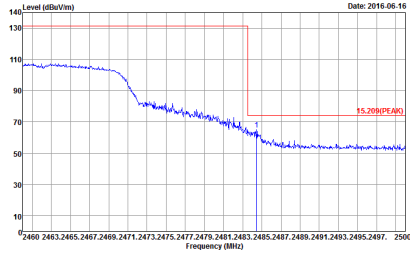
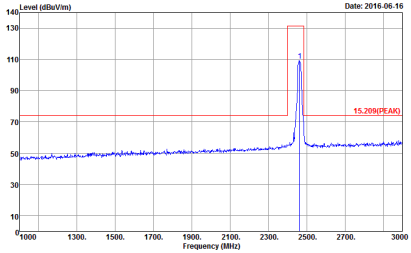
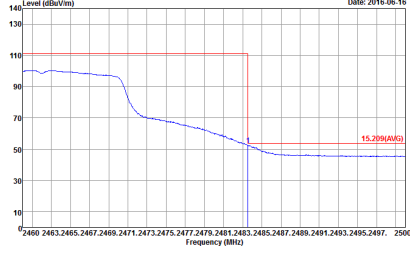
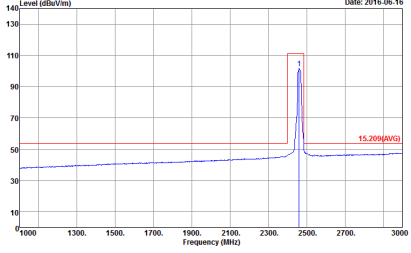

WIFI	2.4GHz 2400~2483.5MHz Band Edge @ 3m	
ANT	802.11g CH11 2462MHz	
2	Horizontal	Fundamental
Peak	 <p>Site : 03CH13-HY Condition : 15.209(PEAK) 3m HORN_9120D_1241 HORIZONTAL Detector : Peak Project : 631725-01 Mode : 21 power setting : 20</p>	 <p>Site : 03CH13-HY Condition : 15.209(PEAK) 3m HORN_9120D_1241 HORIZONTAL Detector : Peak Project : 631725-01 Mode : 21 power setting : 20</p>
Avg.	 <p>Site : 03CH13-HY Condition : 15.209(AVG) 3m HORN_9120D_1241 HORIZONTAL Detector : Peak Project : 631725-01 Mode : 21 power setting : 20</p>	 <p>Site : 03CH13-HY Condition : 15.209(AVG) 3m HORN_9120D_1241 HORIZONTAL Detector : Peak Project : 631725-01 Mode : 21 power setting : 20</p>

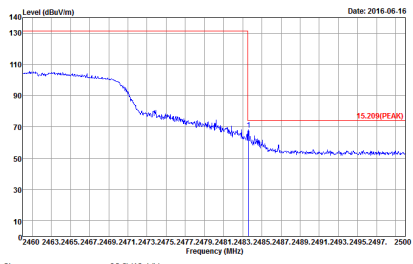
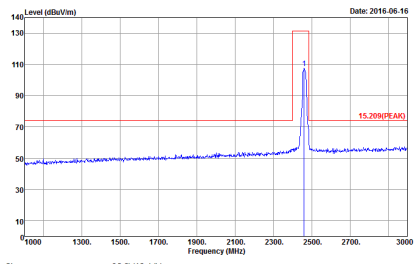
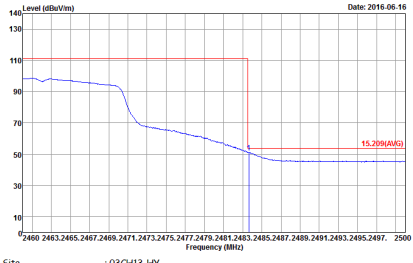
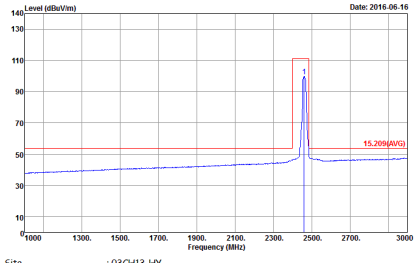

WIFI	2.4GHz 2400~2483.5MHz Band Edge @ 3m	
ANT	802.11g CH11 2462MHz	
2	Vertical	Fundamental
Peak	 <p>Site : 03CH13-HY Condition : 15.209(PEAK) 3m HORN_9120D_1241 VERTICAL : RBW:1000.000KHz VBW:3000.000KHz SWT:Auto Detector : Peak Project : 631725-01 Mode : 21 power setting : 20</p>	 <p>Site : 03CH13-HY Condition : 15.209(PEAK) 3m HORN_9120D_1241 VERTICAL : RBW:1000.000KHz VBW:3000.000KHz SWT:Auto Detector : Peak Project : 631725-01 Mode : 21 power setting : 20</p>
Avg.	 <p>Site : 03CH13-HY Condition : 15.209(AVG) 3m HORN_9120D_1241 VERTICAL : RBW:1000.000KHz VBW:1.000KHz SWT:Auto Detector : Peak Project : 631725-01 Mode : 21 power setting : 20</p>	 <p>Site : 03CH13-HY Condition : 15.209(AVG) 3m HORN_9120D_1241 VERTICAL : RBW:1000.000KHz VBW:1.000KHz SWT:Auto Detector : Peak Project : 631725-01 Mode : 21 power setting : 20</p>



2.4GHz 2400~2483.5MHz

WIFI 802.11n HT20 (Band Edge @ 3m)

WIFI	2.4GHz 2400~2483.5MHz Band Edge @ 3m	
ANT	802.11n HT20 CH01 2412MHz	
2	Horizontal	Fundamental
Peak	<p>Site : 03CH13-HY Condition : 15.209(PEAK) 3m HORN_9120D_1241 HORIZONTAL Detector : Peak Project : 631725-01 Mode : 22 power setting : 18</p>	<p>Site : 03CH13-HY Condition : 15.209(PEAK) 3m HORN_9120D_1241 HORIZONTAL Detector : Peak Project : 631725-01 Mode : 22 power setting : 18</p>
Avg.	<p>Site : 03CH13-HY Condition : 15.209(AVG) 3m HORN_9120D_1241 HORIZONTAL Detector : Peak Project : 631725-01 Mode : 22 power setting : 18</p>	<p>Site : 03CH13-HY Condition : 15.209(AVG) 3m HORN_9120D_1241 HORIZONTAL Detector : Peak Project : 631725-01 Mode : 22 power setting : 18</p>

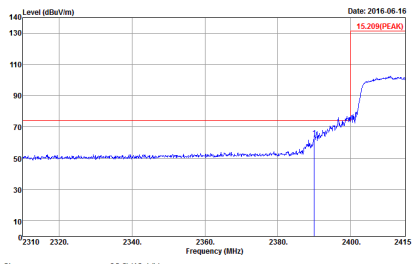
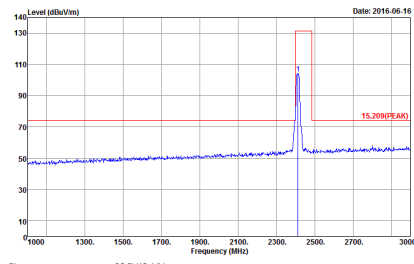
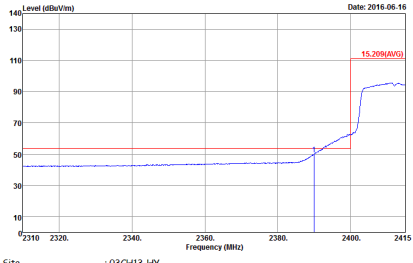
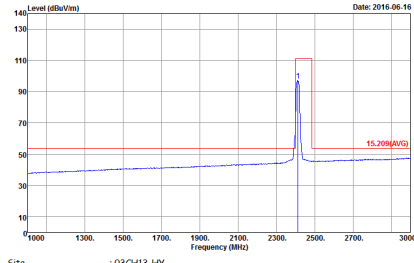

WIFI	2.4GHz 2400~2483.5MHz Band Edge @ 3m	
ANT	802.11n HT20 CH01 2412MHz	
2	Vertical	Fundamental
Peak	 <p>Level (dBuV/m) vs Frequency (MHz) plot for Vertical Peak. The y-axis ranges from 10 to 140 dBuV/m, and the x-axis ranges from 2310 to 2415 MHz. A sharp peak is visible at 2412 MHz, reaching approximately 130 dBuV/m. A red box highlights the peak with the value 15.209(PEAK).</p> <p>Site : 03CH13-HY Condition : 15.209(PEAK) 3m HORN_9120D_1241 VERTICAL RBW:1000.000KHz VBW:3000.000KHz SWT:Auto Detector : Peak Project : 631725-01 Mode : 22 power setting : 18</p>	 <p>Level (dBuV/m) vs Frequency (MHz) plot for Fundamental Peak. The y-axis ranges from 10 to 140 dBuV/m, and the x-axis ranges from 1000 to 3000 MHz. A sharp peak is visible at 2412 MHz, reaching approximately 130 dBuV/m. A red box highlights the peak with the value 15.209(PEAK).</p> <p>Site : 03CH13-HY Condition : 15.209(PEAK) 3m HORN_9120D_1241 VERTICAL RBW:1000.000KHz VBW:3000.000KHz SWT:Auto Detector : Peak Project : 631725-01 Mode : 22 power setting : 18</p>
Avg.	 <p>Level (dBuV/m) vs Frequency (MHz) plot for Vertical Avg. The y-axis ranges from 10 to 140 dBuV/m, and the x-axis ranges from 2310 to 2415 MHz. A broad peak is visible at 2412 MHz, reaching approximately 100 dBuV/m. A red box highlights the peak with the value 15.209(AVG).</p> <p>Site : 03CH13-HY Condition : 15.209(AVG) 3m HORN_9120D_1241 VERTICAL RBW:1000.000KHz VBW:1.000KHz SWT:Auto Detector : Peak Project : 631725-01 Mode : 22 power setting : 18</p>	 <p>Level (dBuV/m) vs Frequency (MHz) plot for Fundamental Avg. The y-axis ranges from 10 to 140 dBuV/m, and the x-axis ranges from 1000 to 3000 MHz. A broad peak is visible at 2412 MHz, reaching approximately 100 dBuV/m. A red box highlights the peak with the value 15.209(AVG).</p> <p>Site : 03CH13-HY Condition : 15.209(AVG) 3m HORN_9120D_1241 VERTICAL RBW:1000.000KHz VBW:1.000KHz SWT:Auto Detector : Peak Project : 631725-01 Mode : 22 power setting : 18</p>

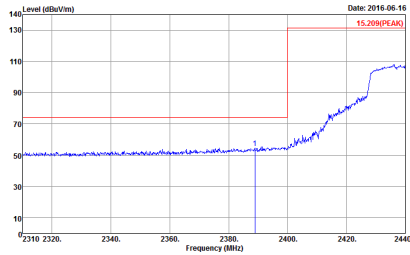
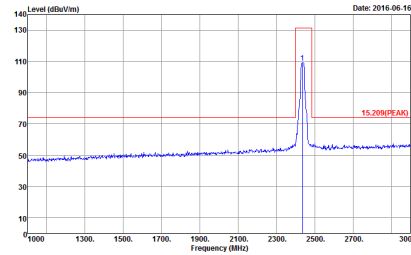
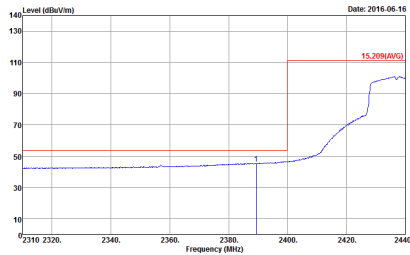
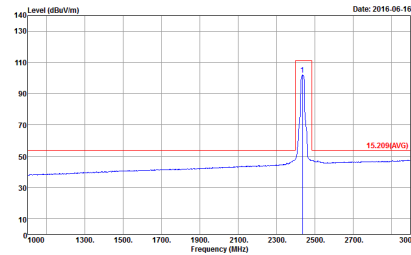

WIFI	2.4GHz 2400~2483.5MHz Band Edge @ 3m	
ANT	802.11n HT20 CH06 2437MHz - L	
2	Horizontal	Fundamental
Peak	 <p>Level (dBuV/m) vs Frequency (MHz) plot for Horizontal orientation. The y-axis ranges from 10 to 140 dBuV/m, and the x-axis ranges from 2310 to 2440 MHz. A peak is observed at 2437 MHz with a level of 15.209 dBuV/m. The plot shows a relatively flat baseline until approximately 2380 MHz, where it begins to rise, reaching the peak at 2437 MHz.</p> <p>Site : 03CH13-HY Condition : 15.209(PEAK) 3m HORN_91200_1241 HORIZONTAL RBW:1000.000KHz VBW:3000.000KHz SWT:Auto Detector : Peak Project : 631725-01 Mode : Z3</p>	 <p>Level (dBuV/m) vs Frequency (MHz) plot for Fundamental orientation. The y-axis ranges from 10 to 140 dBuV/m, and the x-axis ranges from 1000 to 3000 MHz. A sharp peak is observed at 2437 MHz with a level of 15.209 dBuV/m. The rest of the spectrum is flat and near the noise floor.</p> <p>Site : 03CH13-HY Condition : 15.209(PEAK) 3m HORN_91200_1241 HORIZONTAL RBW:1000.000KHz VBW:3000.000KHz SWT:Auto Detector : Peak Project : 631725-01 Mode : Z3</p>
Avg.	 <p>Level (dBuV/m) vs Frequency (MHz) plot for Horizontal orientation showing the average spectrum. The y-axis ranges from 10 to 140 dBuV/m, and the x-axis ranges from 2310 to 2440 MHz. The peak at 2437 MHz is labeled as 15.209(AVG) dBuV/m. The curve is smoother than the peak plot, showing a gradual rise starting around 2380 MHz.</p> <p>Site : 03CH13-HY Condition : 15.209(AVG) 3m HORN_91200_1241 HORIZONTAL RBW:1000.000KHz VBW:1.000KHz SWT:Auto Detector : Peak Project : 631725-01 Mode : Z3</p>	 <p>Level (dBuV/m) vs Frequency (MHz) plot for Fundamental orientation showing the average spectrum. The y-axis ranges from 10 to 140 dBuV/m, and the x-axis ranges from 1000 to 3000 MHz. A sharp peak at 2437 MHz is labeled as 15.209(AVG) dBuV/m. The baseline is very flat across the entire frequency range.</p> <p>Site : 03CH13-HY Condition : 15.209(AVG) 3m HORN_91200_1241 HORIZONTAL RBW:1000.000KHz VBW:1.000KHz SWT:Auto Detector : Peak Project : 631725-01 Mode : Z3</p>

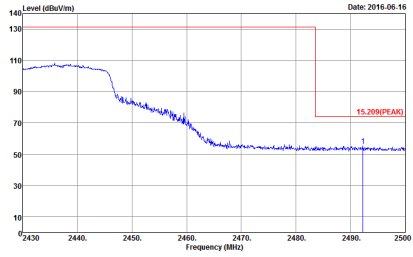
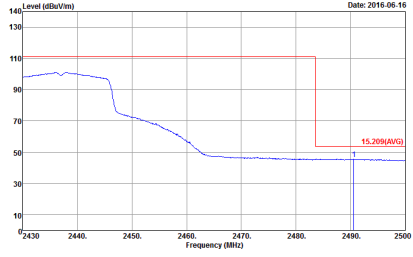

WIFI	2.4GHz 2400~2483.5MHz Band Edge @ 3m	
ANT	802.11n HT20 CH06 2437MHz - R	
2	Horizontal	Fundamental
Peak	 <p>Site : 03CH13-HY Condition : 15.209(MHz) 3m HORN_91200_1241 HORIZONTAL RBW:1000.000KHz VBW:3000.000KHz SWT:Auto Detector : Peak Project : 631725-01 Mode : Z3</p>	Left blank
Avg.	 <p>Site : 03CH13-HY Condition : 15.209(AVG) 3m HORN_91200_1241 HORIZONTAL RBW:1000.000KHz VBW:1000KHz SWT:Auto Detector : Peak Project : 631725-01 Mode : Z3</p>	Left blank



WIFI	2.4GHz 2400~2483.5MHz Band Edge @ 3m	
ANT	802.11n HT20 CH06 2437MHz - L	
2	Vertical	Fundamental
Peak	<p>Site : 03CH13-HY Condition : 15.209(PEAK) 3m HORN_9120D_1241 VERTICAL RBW:1000.000kHz VBW:3000.000kHz SWT:Auto Detector : Peak Project : 631725-01 Mode : Z3</p>	<p>Site : 03CH13-HY Condition : 15.209(PEAK) 3m HORN_9120D_1241 VERTICAL RBW:1000.000kHz VBW:3000.000kHz SWT:Auto Detector : Peak Project : 631725-01 Mode : Z3</p>
Avg.	<p>Site : 03CH13-HY Condition : 15.209(AVG) 3m HORN_9120D_1241 VERTICAL RBW:1000.000kHz VBW:1.000kHz SWT:Auto Detector : Peak Project : 631725-01 Mode : Z3</p>	<p>Site : 03CH13-HY Condition : 15.209(AVG) 3m HORN_9120D_1241 VERTICAL RBW:1000.000kHz VBW:1.000kHz SWT:Auto Detector : Peak Project : 631725-01 Mode : Z3</p>



WIFI	2.4GHz 2400~2483.5MHz Band Edge @ 3m	
ANT	802.11n HT20 CH06 2437MHz - R	
2	Vertical	Fundamental
Peak	<p>Site : 03CH13-HY Condition : 15.209(PEAK) 3m HORN_91200_1241 VERTICAL RBW:1000.000KHz VBW:3000.000KHz SWT:Auto Detector : Peak Project : 631725-01 Mode : 23</p>	Left Blank
Avg.	<p>Site : 03CH13-HY Condition : 15.209(AVG) 3m HORN_91200_1241 VERTICAL RBW:1000.000KHz VBW:1.000KHz SWT:Auto Detector : Peak Project : 631725-01 Mode : 23</p>	Left Blank

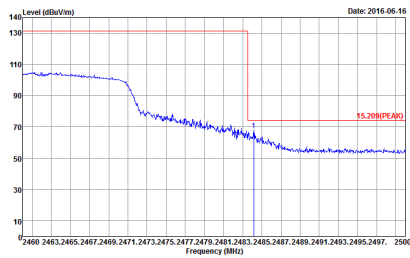
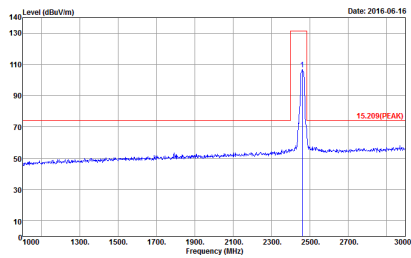
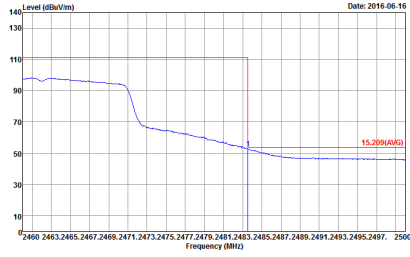
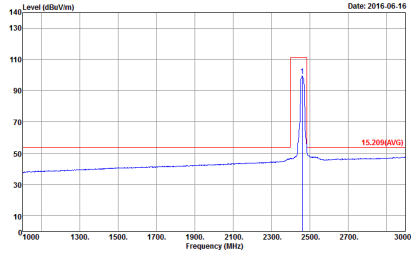

WIFI	2.4GHz 2400~2483.5MHz Band Edge @ 3m	
ANT	802.11n HT20 CH11 2462MHz	
2	Horizontal	Fundamental
Peak	 <p>Site : 03CH13-HY Condition : 15.209(PEAK) 3m HORN_9120D_1241 HORIZONTAL RBW:1000.000KHz VBW:3000.000KHz SWT:Auto Detector : Peak Project : 631725-01 Mode : 24 Power setting : 19</p>	 <p>Site : 03CH13-HY Condition : 15.209(PEAK) 3m HORN_9120D_1241 HORIZONTAL RBW:1000.000KHz VBW:3000.000KHz SWT:Auto Detector : Peak Project : 631725-01 Mode : 24 Power setting : 19</p>
Avg.	 <p>Site : 03CH13-HY Condition : 15.209(AVG) 3m HORN_9120D_1241 HORIZONTAL RBW:1000.000KHz VBW:1.000KHz SWT:Auto Detector : Peak Project : 631725-01 Mode : 24 Power setting : 19</p>	 <p>Site : 03CH13-HY Condition : 15.209(AVG) 3m HORN_9120D_1241 HORIZONTAL RBW:1000.000KHz VBW:1.000KHz SWT:Auto Detector : Peak Project : 631725-01 Mode : 24 Power setting : 19</p>

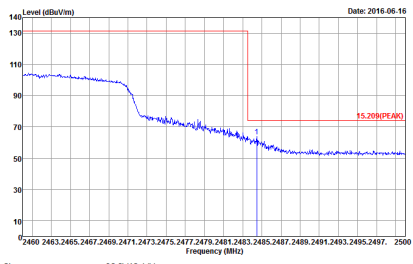
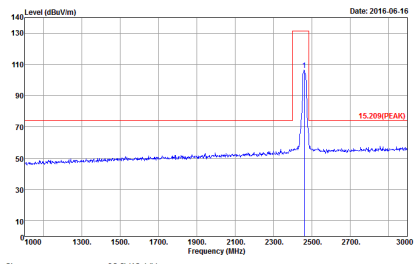
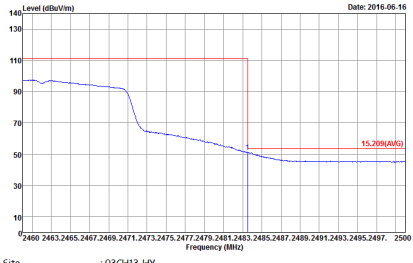
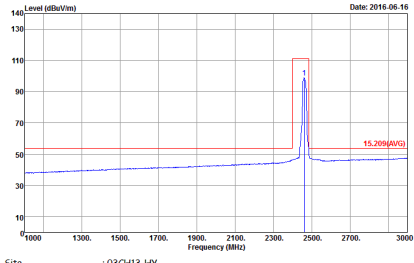

WIFI	2.4GHz 2400~2483.5MHz Fundamental @ 3m	
ANT	802.11n HT20 CH11 2462MHz	
2	Vertical	Fundamental
Peak	 <p>Site : 03CH13-HY Condition : 15.209(PEAK) 3m HORN_9120D_1241 VERTICAL RBW:1000.000KHz VBW:3000.000KHz SWT:Auto Detector : Peak Project : 631725-01 Mode : 24 Power setting : 19</p>	 <p>Site : 03CH13-HY Condition : 15.209(PEAK) 3m HORN_9120D_1241 VERTICAL RBW:1000.000KHz VBW:3000.000KHz SWT:Auto Detector : Peak Project : 631725-01 Mode : 24 Power setting : 19</p>
Avg.	 <p>Site : 03CH13-HY Condition : 15.209(AVG) 3m HORN_9120D_1241 VERTICAL RBW:1000.000KHz VBW:1.000KHz SWT:Auto Detector : Peak Project : 631725-01 Mode : 24 Power setting : 19</p>	 <p>Site : 03CH13-HY Condition : 15.209(AVG) 3m HORN_9120D_1241 VERTICAL RBW:1000.000KHz VBW:1.000KHz SWT:Auto Detector : Peak Project : 631725-01 Mode : 24 Power setting : 19</p>



2.4GHz 2400~2483.5MHz
WIFI 802.11b (Harmonic @ 3m)

Table with 2 columns: Horizontal and Vertical. Each column contains a spectrum plot showing Level (dBuV/m) vs Frequency (MHz) with peak and average values marked at 15.209 MHz. Includes site and condition details for both orientations.

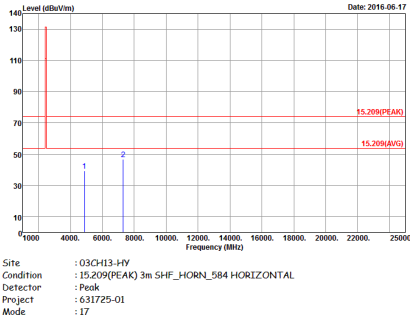
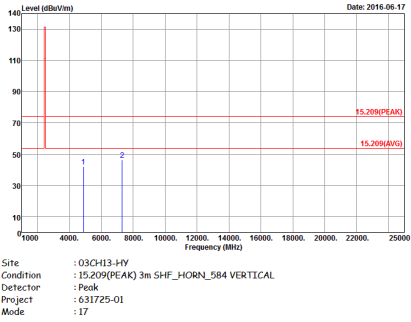

WIFI	2.4GHz 2400~2483.5MHz Harmonic @ 3m	
ANT	802.11b CH06 2437MHz	
2	Horizontal	Vertical
Peak Avg.	 <p>Site : 03CH13-#HY Condition : 15.209(Peak) 3m SHF_HORN_584 HORIZONTAL Detector : Peak Project : 631725-01 Mode : 17</p>	 <p>Site : 03CH13-#HY Condition : 15.209(Peak) 3m SHF_HORN_584 VERTICAL Detector : Peak Project : 631725-01 Mode : 17</p>

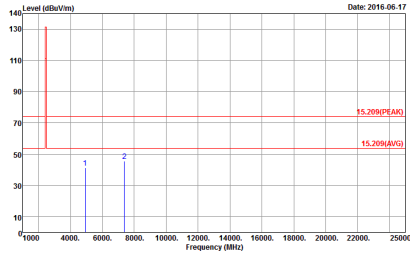
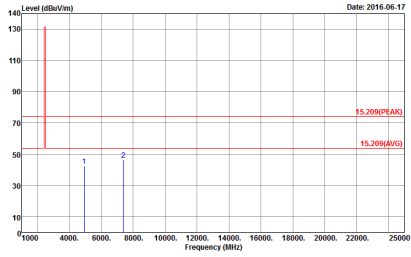

WIFI	2.4GHz 2400~2483.5MHz Harmonic @ 3m	
ANT	802.11b CH11 2462MHz	
2	Horizontal	Vertical
Peak Avg.	 <p>Site : 03CH13-#HY Condition : 15.209(PEAK) 3m SHF_HORN_584 HORIZONTAL Detector : Peak Project : 631725-01 Mode : 18</p>	 <p>Site : 03CH13-#HY Condition : 15.209(PEAK) 3m SHF_HORN_584 VERTICAL Detector : Peak Project : 631725-01 Mode : 18</p>



2.4GHz 2400~2483.5MHz
WIFI 802.11g (Harmonic @ 3m)

WIFI	2.4GHz 2400~2483.5MHz Harmonic @ 3m	
ANT	802.11g CH01 2412MHz	
2	Horizontal	Vertical
Peak Avg.	<p>Site : 03CH13-HY Condition : 15.209(PEAK) 3m SHF_HORN_584 HORIZONTAL Detector : Peak Project : 631725-01 Mode : 19</p>	<p>Site : 03CH13-HY Condition : 15.209(PEAK) 3m SHF_HORN_584 VERTICAL Detector : Peak Project : 631725-01 Mode : 19</p>

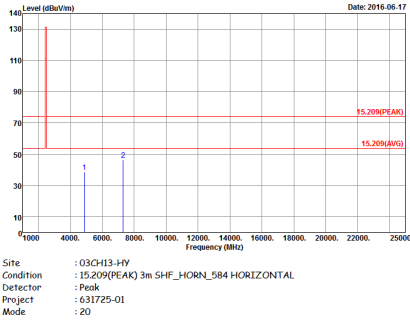
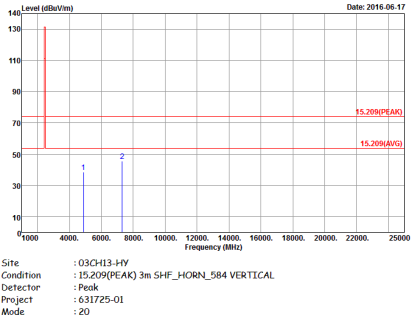

WIFI	2.4GHz 2400~2483.5MHz Harmonic @ 3m	
ANT	802.11g CH06 2437MHz	
2	Horizontal	Vertical
Peak Avg.	 <p>Site : 03CH13-4Y Condition : 15.209(Peak) 3m SHF_HORN_584 HORIZONTAL Detector : Peak Project : 631725-01 Mode : 20</p>	 <p>Site : 03CH13-4Y Condition : 15.209(Peak) 3m SHF_HORN_584 VERTICAL Detector : Peak Project : 631725-01 Mode : 20</p>

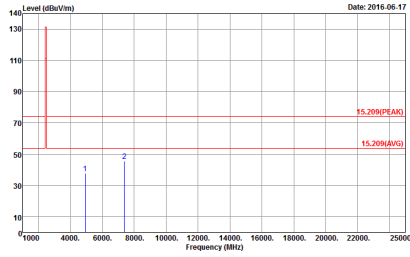
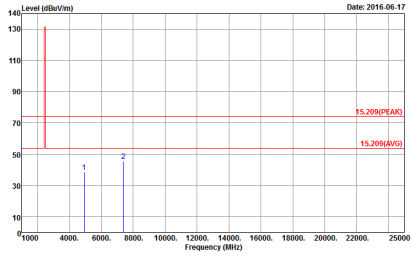

WIFI	2.4GHz 2400~2483.5MHz Harmonic @ 3m	
ANT	802.11g CH11 2462MHz	
2	Horizontal	Vertical
Peak Avg.	 <p>Site : 03CH13-#HY Condition : 15.209(Peak) 3m SHF_HORN_584 HORIZONTAL Detector : Peak Project : 631725-01 Mode : Z1</p>	 <p>Site : 03CH13-#HY Condition : 15.209(Peak) 3m SHF_HORN_584 VERTICAL Detector : Peak Project : 631725-01 Mode : Z1</p>



2.4GHz 2400~2483.5MHz
WIFI 802.11n HT20 (Harmonic @ 3m)

Table with 3 columns: WIFI, ANT, and measurement results for Horizontal and Vertical orientations. Includes two graphs showing Level (dBuV/m) vs Frequency (MHz) and associated site/condition details.



WIFI	2.4GHz 2400~2483.5MHz Harmonic @ 3m	
ANT	802.11n HT20 CH06 2437MHz	
2	Horizontal	Vertical
Peak Avg.	<p>Site : 03CH13-HY Condition : 15.209(Peak) 3m SHF_HORN_584 HORIZONTAL Detector : Peak Project : 631725-01 Mode : 23</p>	<p>Site : 03CH13-HY Condition : 15.209(Peak) 3m SHF_HORN_584 VERTICAL Detector : Peak Project : 631725-01 Mode : 23</p>



WIFI	2.4GHz 2400~2483.5MHz Harmonic @ 3m	
ANT	802.11n HT20 CH11 2462MHz	
2	Horizontal	Vertical
Peak Avg.	<p>Site : 03CH13-HY Condition : 15.209(Peak) 3m SHF_HORN_584 HORIZONTAL Detector : Peak Project : 631725-01 Mode : 24</p>	<p>Site : 03CH13-HY Condition : 15.209(Peak) 3m SHF_HORN_584 VERTICAL Detector : Peak Project : 631725-01 Mode : 24</p>

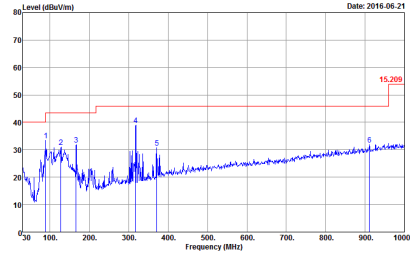
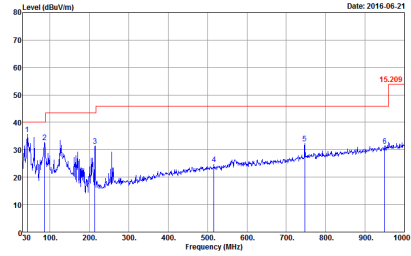

**Emission below 1GHz
2.4GHz WIFI 802.11n HT20 (LF)**

WIFI	2.4GHz 2400~2483.5MHz	
ANT	802.11n HT20 LF	
2	Horizontal	Vertical
<p>QP / Peak</p>	 <p>Site : 03CH13-HY Condition : 15.209 3m BILOG_40103 HORIZONTAL Detector : Peak Project : 631725-01 Mode : 28</p>	 <p>Site : 03CH13-HY Condition : 15.209 3m BILOG_40103 VERTICAL Detector : Peak Project : 631725-01 Mode : 28</p>



Appendix D. Duty Cycle Plots

Antenna	Band	Duty Cycle(%)	T(us)	1/T(kHz)	VBW Setting
1	802.11b	97.66	8360.00	0.12	300Hz
2	802.11b	97.66	8360.00	0.12	300Hz
1	802.11g	88.46	1380.00	0.72	1kHz
2	802.11g	88.61	1400.00	0.71	1kHz
1	2.4GHz 802.11n HT20	86.49	1280.00	0.78	1kHz
2	2.4GHz 802.11n HT20	87.84	1300.00	0.77	1kHz



<Ant. 1>

802.11b

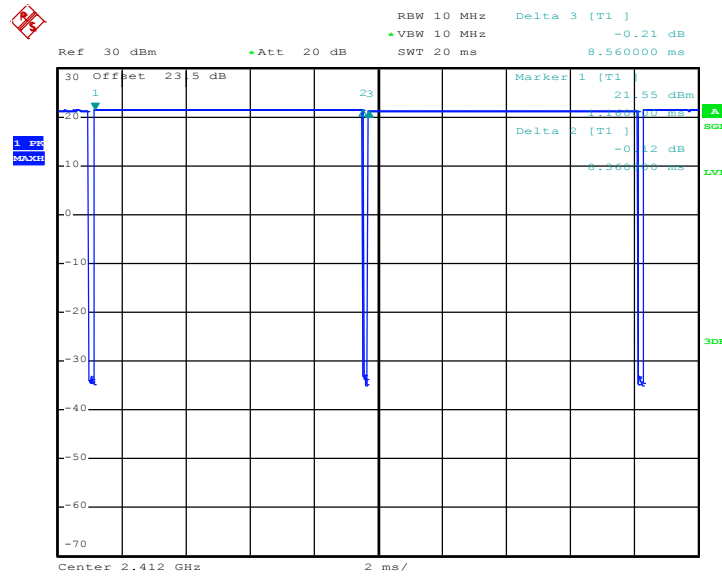

Date: 13.JUN.2016 23:19:03

802.11g

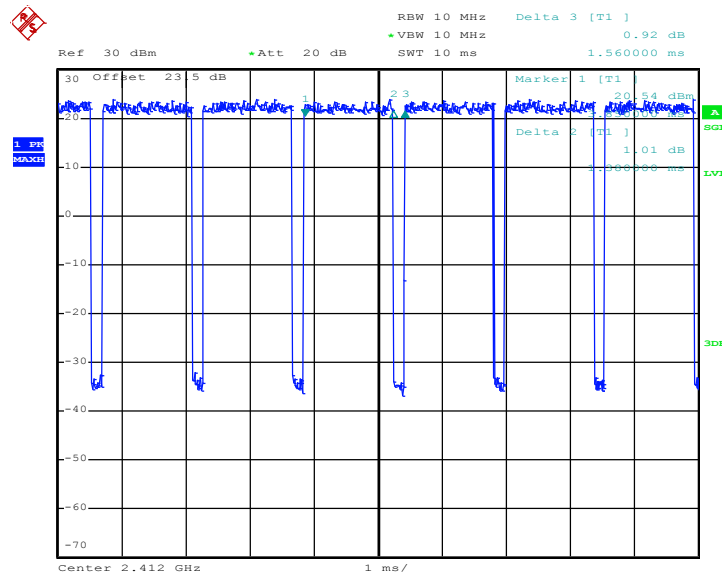

Date: 13.JUN.2016 23:42:46



802.11n HT20

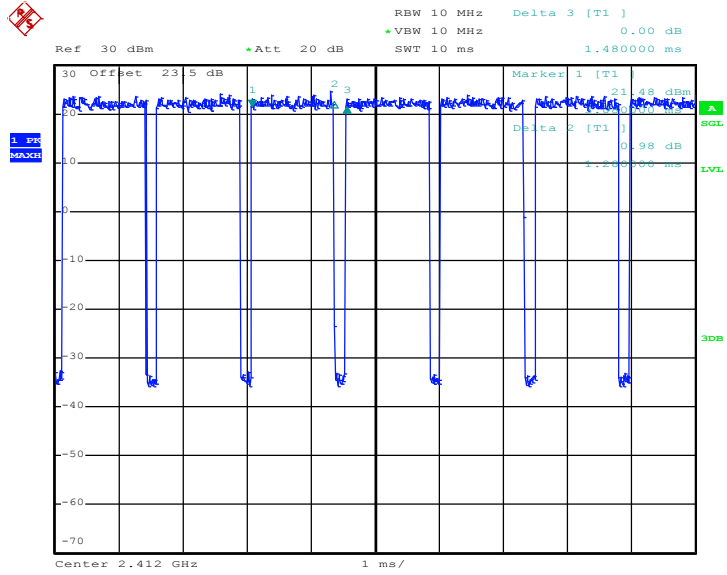

Date: 13.JUN.2016 23:55:49



<Ant. 2>

802.11b

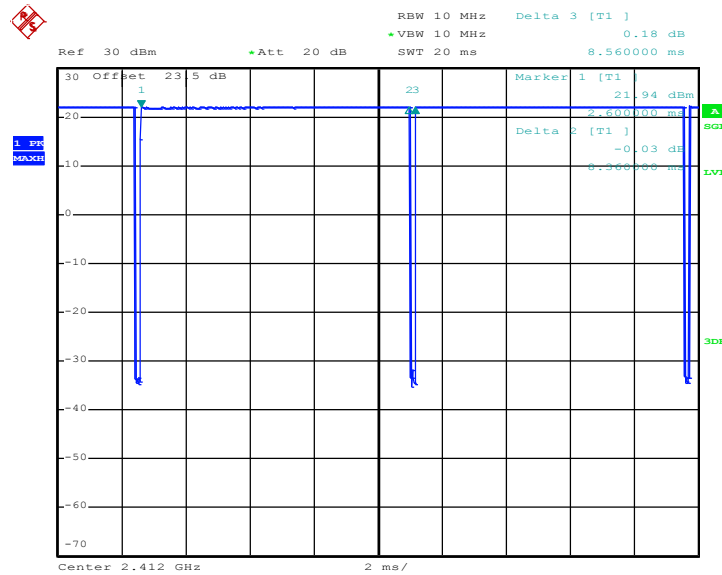

Date: 13.JUN.2016 23:24:47

802.11g

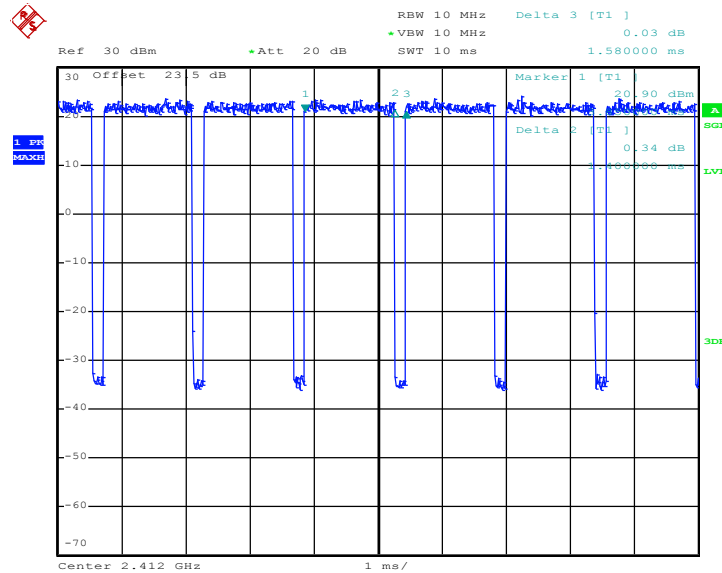

Date: 13.JUN.2016 23:47:43



802.11n HT20

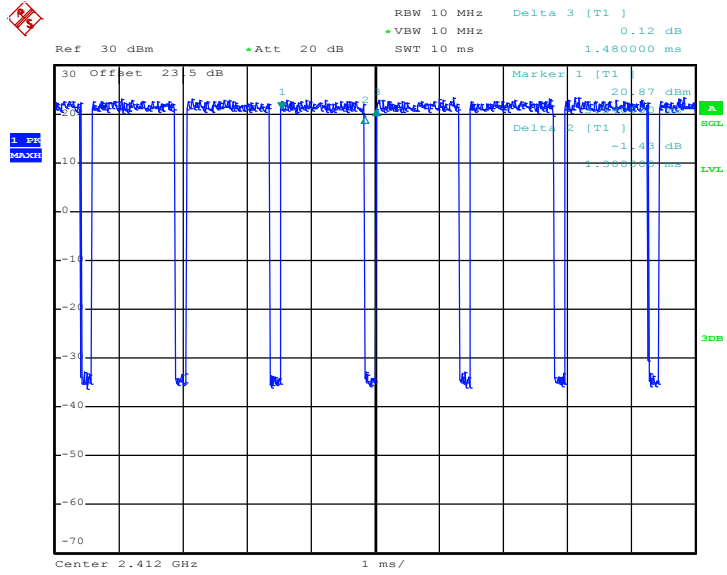

Date: 13.JUN.2016 23:52:22