



# EMC TEST REPORT

**Applicant**      Positioning Universal Inc  
**FCC ID**          2AHRH-FJ950M  
**Product**        GPS Tracker  
**Model**          TM95M  
**Report No.**     R2106A0473-E1  
**Issue Date**    June 17, 2021

TA Technology (Shanghai) Co., Ltd. tested the above equipment in accordance with the requirements in **FCC Code CFR47 Part15B (2020)/ ANSI C63.4 (2014)**. The test results show that the equipment tested is capable of demonstrating compliance with the requirements as documented in this report.

*Wei Liu*

Prepared by: Wei Liu

*Guangchang Fan*

Approved by: Guangchang Fan

---

**TA Technology (Shanghai) Co., Ltd.**

No.145, Jintang Rd, Tangzhen Industry Park, Pudong Shanghai, China

TEL: +86-021-50791141/2/3

FAX: +86-021-50791141/2/3-8000



## Table of Contents

1	Test Laboratory.....	4
1.1	Notes of the Test Report.....	4
1.2	Test facility.....	4
1.3	Testing Location.....	4
2	General Description of Equipment under Test.....	5
2.1	Applicant and Manufacturer Information.....	5
2.2	General information.....	5
2.3	Applied Standards.....	6
2.4	Test Mode.....	7
3	Test Case Results.....	8
3.1	Radiated Emission.....	8
3.2	Conducted Emission.....	13
4	Main Test Instruments.....	16
	ANNEX A: The EUT Appearance.....	17
	ANNEX B: Test Setup Photos.....	18



### Summary of measurement results

Number	Test Case	Clause in FCC Rules	Conclusion
1	Radiated Emission	FCC Part15.109, ANSI C63.4-2014	PASS
2	Conducted Emission	FCC Part15.107, ANSI C63.4-2014	PASS
Date of Testing: June 3, 2021 ~June 9, 2021 Date of Sample Received: June 1, 2021			
Note: All indications of Pass/Fail in this report are opinions expressed by TA Technology (Shanghai) Co., Ltd. based on interpretations and/or observations of test results. Measurement Uncertainties were not taken into account and are published for informational purposes only.			

## 1 Test Laboratory

### 1.1 Notes of the Test Report

This report shall not be reproduced in full or partial, without the written approval of **TA technology (shanghai) co., Ltd.** The results documented in this report apply only to the tested sample, under the conditions and modes of operation as described herein. Measurement Uncertainties were not taken into account and are published for informational purposes only. This report is written to support regulatory compliance of the applicable standards stated above.

### 1.2 Test facility

#### **FCC (Designation number: CN1179, Test Firm Registration Number: 446626)**

TA Technology (Shanghai) Co., Ltd. has been listed on the US Federal Communications Commission list of test facilities recognized to perform measurements.

#### **A2LA (Certificate Number: 3857.01)**

TA Technology (Shanghai) Co., Ltd. has been listed by American Association for Laboratory Accreditation to perform measurement.

### 1.3 Testing Location

Company: TA Technology (Shanghai) Co., Ltd.  
Address: No.145, Jintang Rd, Tangzhen Industry Park, Pudong Shanghai, China  
City: Shanghai  
Post code: 201201  
Country: P. R. China  
Contact: Fan Guangchang  
Telephone: +86-021-50791141/2/3  
Fax: +86-021-50791141/2/3-8000  
Website: <http://www.ta-shanghai.com>  
E-mail: [fanguangchang@ta-shanghai.com](mailto:fanguangchang@ta-shanghai.com)

## 2 General Description of Equipment under Test

### 2.1 Applicant and Manufacturer Information

<b>Applicant</b>	Positioning Universal Inc
<b>Applicant address</b>	4660 La Jolla Village Drive Suite 1100 , San Diego / California /United States
<b>Manufacturer</b>	Positioning Universal Inc
<b>Manufacturer address</b>	4660 La Jolla Village Drive Suite 1100 , San Diego / California /United States

### 2.2 General information

EUT Description			
Device Type	Movable Device		
Model	TM95M		
Lab internal SN	R2106A0473/S01		
HW Version	TM95M_P1_V01		
SW Version	TM95_2_3_45_B0_FULL.bin		
Antenna Type	Internal Antenna		
Frequency	Band	Tx (MHz)	Rx (MHz)
	LTE Band 2	1850 ~ 1910	1930 ~ 1990
	LTE Band 4	1710 ~ 1755	2110 ~ 2155
	LTE Band 12	699 ~ 716	729 ~ 746
	LTE Band 13	777 ~ 787	746 ~ 756
	LTE Band 25	1850 ~ 1915	1930 ~ 1995
Note: The EUT is sent from the applicant to TA and the information of the EUT is declared by the applicant.			



## 2.3 Applied Standards

According to the specifications of the manufacturer, it must comply with the requirements of the following standards:

### Test standards

**FCC Code CFR47 Part15B (2020)**

**ANSI C63.4 (2014)**



## 2.4 Test Mode

Test Mode	
Mode 1	External Power Supply + EUT + Receiver

### 3 Test Case Results

#### 3.1 Radiated Emission

##### Ambient condition

Temperature	Relative humidity	Pressure
23°C~26°C	45%~50%	101.5kPa

##### Methods of Measurement

The EUT is placed on a non-metallic table 0.8m above the horizontal metal reference ground plane. The distance between EUT and receive antenna should be 3 meters. During the test, the EUT was operating in its typical mode. The test method is according to ANSI C63.4-2014. Sweep the whole frequency band through the range from 30MHz to the 5th harmonic of the carrier. During the test, the height of receive antenna shall be moved from 1 to 4 meters, and the antenna shall be performed under horizontal and vertical polarization. The turn table shall be rotated from 0 to 360 degrees for detecting the maximum of radiated signal level.

The data of cable loss and antenna factor has been calibrated in full testing frequency range before the testing. During the test, the EUT is worked at maximum output power.

Set the spectrum analyzer in the following:

Below 1GHz:

RBW=100 kHz / VBW=300 kHz / Sweep=AUTO

Above 1GHz:

(a) PEAK Detector: RBW=1MHz / VBW=3MHz / Sweep=AUTO

(b) AVERAGE Detector: RBW=1MHz / VBW=3MHz / Sweep=AUTO

The radiated emission was measured in the following position: EUT stand-up position (Z axis), lie-down position (X, Y axis). The worst emission was found in lie-down position (X axis) and the worst case was recorded.



**Test Setup**

**Below 1GHz**

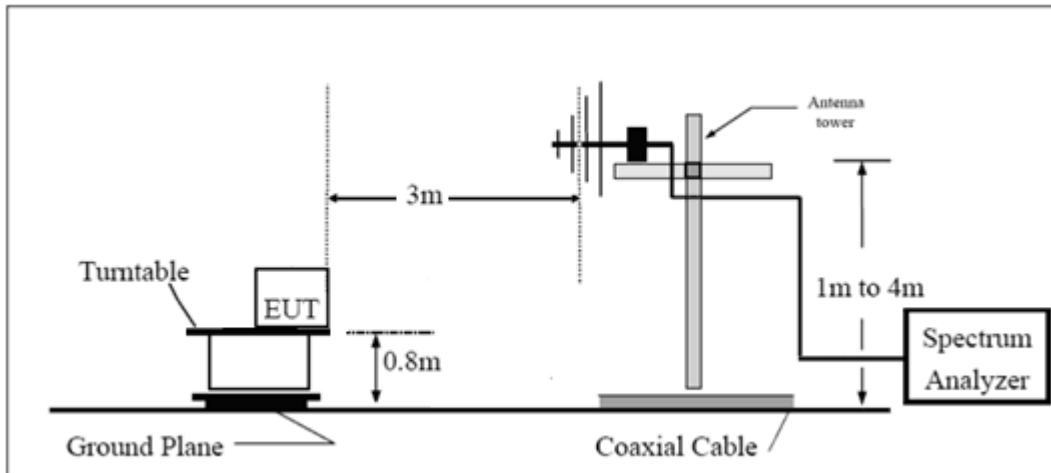

**Above 1GHz**

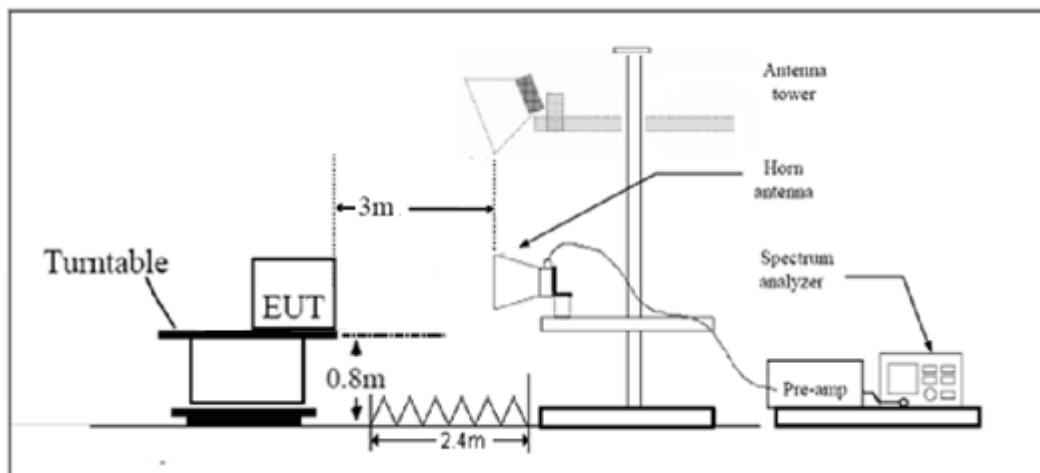

Note: Area side: 2.4mX3.6m

Antenna Tower meets ANSI C63.4 requirements for measurements above 1 GHz by keeping the antenna aimed at the EUT during the antenna's ascent/ descent along the antenna mast.

**Limits****Class B**

Frequency (MHz)	Field Strength (dB $\mu$ V/m)	Detector
30 -88	40.0	Quasi-peak
88-216	43.5	Quasi-peak
216 – 960	46.0	Quasi-peak
960-1000	54.0	Quasi-peak
1000-5 <sup>th</sup> harmonic of the highest frequency or 40GHz, which is lower	54 74	Average Peak

**Measurement Uncertainty**

The assessed measurement uncertainty to ensure 95% confidence level for the normal distribution is with the coverage factor  $k = 1.96$ .

Frequency	Uncertainty
30MHz~200MHz	4.17 dB
200MHz~1000MHz	4.84 dB
1GHz~18GHz	4.35 dB

**Test Results**

Sweep the whole frequency band through the range from 30MHz to the 5th harmonic of the carrier, the Emissions in the frequency band 18GHz –40GHz is more than 20dB below the limit are not reported.

The following graphs display the maximum values of horizontal and vertical by software.  
For above 1GHz, Blue trace uses the peak detection, Green trace uses the average detection.

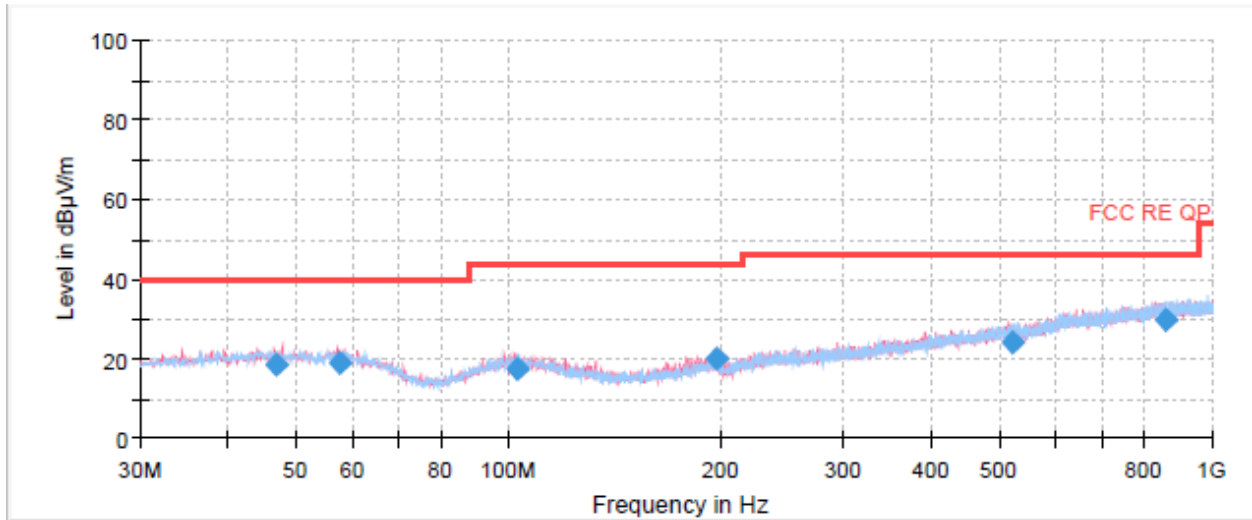

Radiated Emission from 30MHz to 1GHz

Frequency (MHz)	Quasi-Peak (dBuV/m)	Height (cm)	Polarization	Azimuth (deg)	Correct Factor (dB)	Margin (dB)	Limit (dBuV/m)
46.702500	18.52	113.0	V	298.0	14.1	21.48	40.00
57.758750	18.94	214.0	V	285.0	14.4	21.06	40.00
103.305000	17.35	225.0	V	145.0	13.0	26.15	43.50
198.011250	20.24	225.0	V	226.0	12.1	23.26	43.50
520.211250	24.19	100.0	H	11.0	19.8	21.81	46.00
858.216250	29.99	113.0	H	6.0	24.1	16.01	46.00

**Remark: 1. Correction Factor = Antenna factor + Insertion loss(cable loss+amplifier gain)**

**2. Margin = Limit – Quasi-Peak**

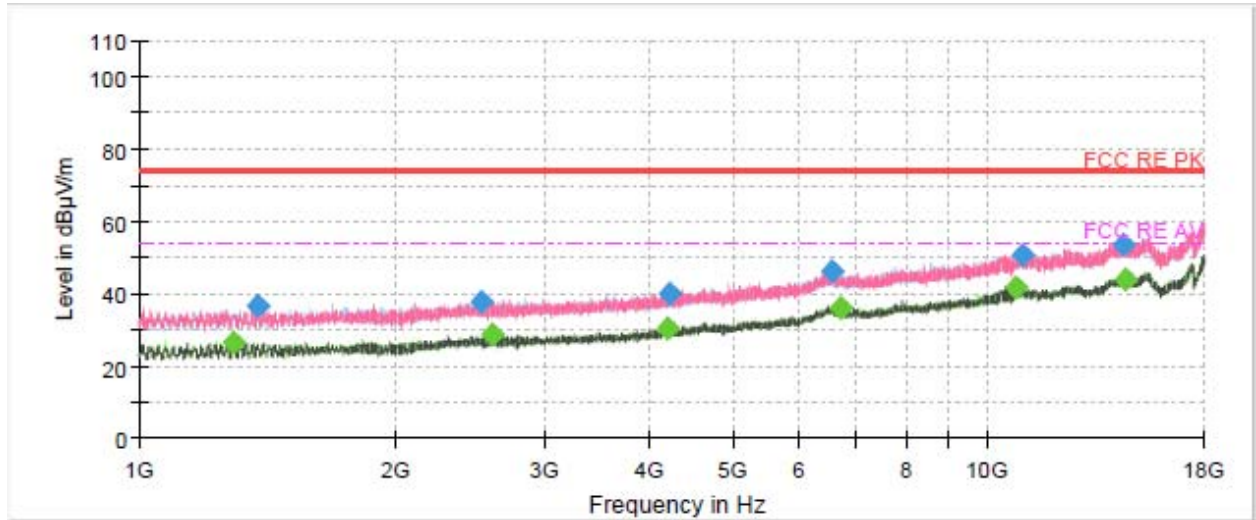

Radiated Emission from 1GHz to 18GHz

Frequency (MHz)	MaxPeak (dBµV/m)	Average (dBµV/m)	Limit (dBµV/m)	Margin (dB)	Height (cm)	Pol	Azimuth (deg)	Corr. (dB/m)
1291.833333	---	26.70	54.00	27.30	200.0	H	214.0	-19.8
1379.666667	36.68	---	74.00	37.32	200.0	H	114.0	-19.6
2535.666667	37.75	---	74.00	36.25	200.0	V	278.0	-16.3
2604.233333	---	28.73	54.00	25.27	200.0	H	156.0	-16.1
4188.633333	---	30.64	54.00	23.36	200.0	V	332.0	-12.7
4215.266667	40.11	---	74.00	33.89	200.0	H	20.0	-12.7
6566.366667	46.41	---	74.00	27.59	200.0	V	291.0	-3.6
6706.900000	---	36.06	54.00	17.94	200.0	V	250.0	-3.5
10797.100000	---	41.53	54.00	12.47	200.0	H	156.0	-0.5
10996.000000	50.87	---	74.00	23.13	200.0	V	278.0	0.1
14415.266667	53.87	---	74.00	20.13	200.0	V	250.0	5.2
14489.500000	---	44.01	54.00	9.99	200.0	V	354.0	5.2

### 3.2 Conducted Emission

#### Ambient condition

Temperature	Relative humidity	Pressure
23°C~26°C	45%~50%	101.5kPa

#### Methods of Measurement

The EUT is placed on a non-metallic table of 80cm height above the horizontal metal reference ground plane. During the test, the EUT was operating in its typical mode. The test method is according to ANSI C63.4-2014. Connect the AC power line of the EUT to the L.I.S.N. Use EMI receiver to detect the average and Quasi-peak value. RBW is set to 9 kHz, VBW is set to 30kHz. The measurement result should include both L line and N line.

#### Test Setup

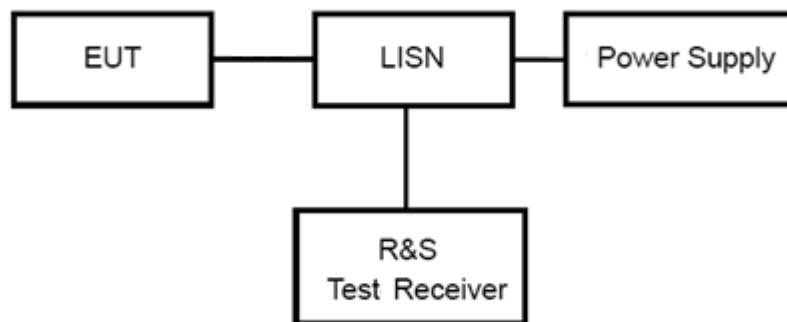

Note: Power Supply is AC Power source and it is used to change the voltage 120V/60Hz.

#### Limits

Frequency (MHz)	Conducted Limits(dBμV)	
	Quasi-peak	Average
0.15 - 0.5	66 to 56 *	56 to 46 *
0.5 - 5	56	46
5 - 30	60	50

\*: Decreases with the logarithm of the frequency.

#### Measurement Uncertainty

The assessed measurement uncertainty to ensure 95% confidence level for the normal distribution is with the coverage factor  $k = 1.96$ .  $U = 2.57$  dB.

**Test Results**

Following plots, Blue trace uses the peak detection; Green trace uses the average detection.

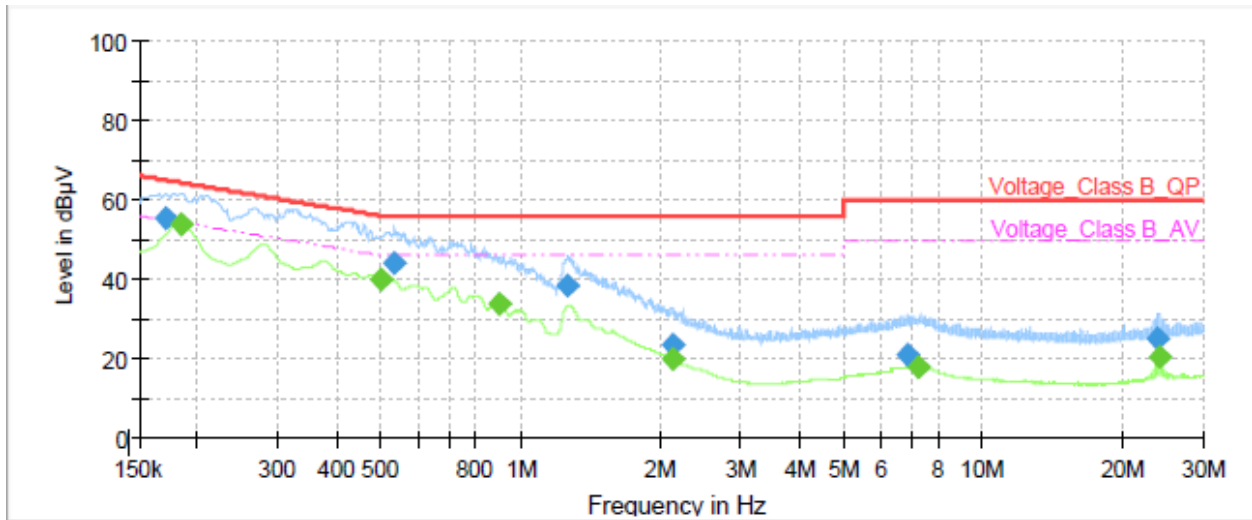

Frequency (MHz)	QuasiPeak (dBµV)	Average (dBµV)	Limit (dBµV)	Margin (dB)	Meas. Time (ms)	Bandwidth (kHz)	Line	Filter	Corr. (dB)
0.17	55.41	---	64.90	9.49	70.0	9.000	L1	ON	21
0.18	---	53.81	54.40	0.59	70.0	9.000	L1	ON	21
0.50	---	40.19	46.00	5.81	70.0	9.000	L1	ON	20
0.53	44.18	---	56.00	11.82	70.0	9.000	L1	ON	20
0.90	---	33.88	46.00	12.12	70.0	9.000	L1	ON	20
1.26	38.44	---	56.00	17.56	70.0	9.000	L1	ON	20
2.12	---	20.24	56.00	32.30	70.0	9.000	L1	ON	20
2.12	23.70	---	46.00	25.76	70.0	9.000	L1	ON	20
6.89	20.81	---	60.00	39.19	70.0	9.000	L1	ON	20
7.28	---	18.00	50.00	32.00	70.0	9.000	L1	ON	20
23.83	24.91	---	60.00	35.09	70.0	9.000	L1	ON	20
23.98	---	20.68	50.00	29.32	70.0	9.000	L1	ON	20

**Remark: Correct factor=cable loss + LISN factor**

L line

Conducted Emission from 150 KHz to 30 MHz

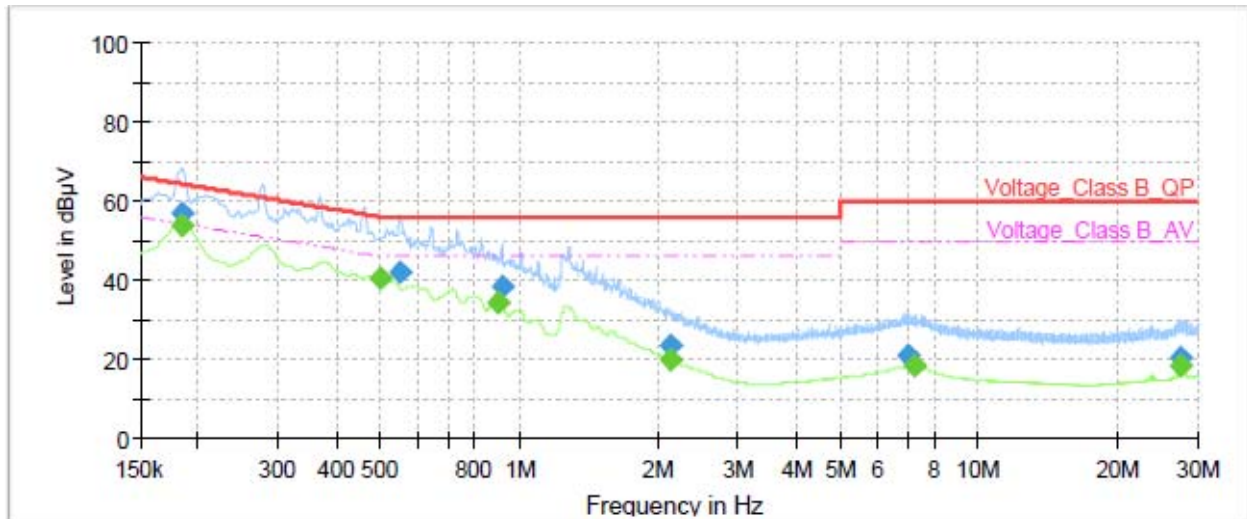

Frequency (MHz)	QuasiPeak (dBµV)	Average (dBµV)	Limit (dBµV)	Margin (dB)	Meas. Time (ms)	Bandwidth (kHz)	Line	Filter	Corr. (dB)
0.18	57.12	---	54.40	0.34	70.0	9.000	N	ON	21
0.18	---	54.06	64.40	7.28	70.0	9.000	N	ON	21
0.50	---	40.34	46.00	5.66	70.0	9.000	N	ON	20
0.55	42.27	---	56.00	13.73	70.0	9.000	N	ON	20
0.90	---	34.14	46.00	11.86	70.0	9.000	N	ON	20
0.92	38.22	---	56.00	17.78	70.0	9.000	N	ON	20
2.12	---	20.23	56.00	32.27	70.0	9.000	N	ON	20
2.12	23.73	---	46.00	25.77	70.0	9.000	N	ON	20
7.00	21.13	---	60.00	38.87	70.0	9.000	N	ON	20
7.23	---	18.28	50.00	31.72	70.0	9.000	N	ON	20
27.35	20.31	---	60.00	39.69	70.0	9.000	N	ON	20
27.43	---	18.50	50.00	31.50	70.0	9.000	N	ON	20

Remark: Correct factor=cable loss + LISN factor

N line

Conducted Emission from 150 KHz to 30 MHz

## 4 Main Test Instruments

Name	Manufacturer	Type	Serial Number	Calibration Date	Expiration Time
Spectrum Analyzer	R&S	FSV40	15195-01-00	2021-05-15	2022-05-14
EMI Test Receiver	R&S	ESCI	100948	2021-05-15	2022-05-14
Trilog Antenna	SCHWARZBECK	VULB 9163	391	2019-12-16	2022-12-15
Horn Antenna	R&S	HF907	102723	2018-08-11	2021-08-10
Horn Antenna	ETS-Lindgren	3160-09	00102643	2018-06-20	2021-06-19
EMI Test Receiver	R&S	ESR	101667	2021-05-16	2022-05-15
LISN	R&S	ENV216	101171	2018-12-15	2021-12-14
Bore Sight Antenna mast	ETS	2171B	00058752	/	/
Test software	EMC32	R&S	9.26.0	/	/

\*\*\*\*\*END OF REPORT \*\*\*\*\*





## **ANNEX A: The EUT Appearance**

The EUT Appearance are submitted separately.



## **ANNEX B: Test Setup Photos**

**The Test Setup Photos are submitted separately.**