

RF TEST REPORT

Applicant	Positioning Universal Inc
FCC ID	2AHRH-FJ1600LW
Product	GPS TRACK
Brand	PUI
Model	FJ1600LW
Report No.	R2406A0659-R3
Issue Date	July 11, 2024

Eurofins TA Technology (Shanghai) Co., Ltd. tested the above equipment in accordance with the requirements in **FCC CFR47 Part 2 (2023)/ FCC CFR47 Part 27C (2023)**. The test results show that the equipment tested is capable of demonstrating compliance with the requirements as documented in this report.

Prepared by: Xu Ying

Approved by: Xu Kai

Eurofins TA Technology (Shanghai) Co., Ltd.

Building 3, No.145, Jintang Rd, Pudong Shanghai, P.R.China

TEL: +86-021-50791141/2/3

FAX: +86-021-50791141/2/3-8000

TABLE OF CONTENT

1	Test Laboratory	4
1.1	Notes of the Test Report.....	4
1.2.	Test facility	4
1.3	Testing Location.....	4
2	General Description of Equipment under Test	5
2.1	Applicant and Manufacturer Information	5
2.2	General information	5
3	Applied Standards	7
4	Test Configuration	8
5	Test Case	9
5.1	RF Power Output and Effective Isotropic Radiated Power	9
5.2	Radiated Spurious Emission	11
6	Test Results	15
6.1	RF Power Output and Effective Isotropic Radiated Power	15
6.2	Radiated Spurious Emission	27
7	Main Test Instruments	31
ANNEX A: The EUT Appearance		32
ANNEX B: Test Setup Photos		33

Summary of Measurement Results

Number	Test Case	Clause in FCC rules	Verdict
1	RF Power Output and Effective Isotropic Radiated Power	2.1046 /27.50(d)(4) /27.50(b)(10) /27.50(c)(10)	PASS
2	Radiated Spurious Emission	2.1053 /27.53(h) /27.53(g) /27.53(f) /27.53(c)	PASS
Date of Testing: June 26, 2024 ~ July 2, 2024 Date of Sample Received: June 18, 2024			
<p>Note: PASS: The EUT complies with the essential requirements in the standard. FAIL: The EUT does not comply with the essential requirements in the standard. All indications of Pass/Fail in this report are opinions expressed by Eurofins TA Technology (Shanghai) Co., Ltd. based on interpretations and/or observations of test results. Measurement Uncertainties were not taken into account and are published for informational purposes only.</p>			

Only RF Power Output and Radiated Spurious Emission is tested for FJ1600LW in this report, and Effective Isotropic Radiated Power also re-evaluated.
Other test items refer to the Module report (Report No.: TELI0004.0 Rev.4, FCC ID: R17LE910CXWWX).

1 Test Laboratory

1.1 Notes of the Test Report

This report shall not be reproduced in full or partial, without the written approval of **Eurofins TA Technology (Shanghai) Co., Ltd.** The results documented in this report apply only to the tested sample, under the conditions and modes of operation as described herein. Measurement Uncertainties were not taken into account and are published for informational purposes only. This report is written to support regulatory compliance of the applicable standards stated above.

1.2. Test facility

FCC (Designation number: CN1179, Test Firm Registration Number: 446626)

Eurofins TA Technology (Shanghai) Co., Ltd. has been listed on the US Federal Communications Commission list of test facilities recognized to perform measurements.

A2LA (Certificate Number: 3857.01)

Eurofins TA Technology (Shanghai) Co., Ltd. has been listed by American Association for Laboratory Accreditation to perform measurement.

1.3 Testing Location

Company: Eurofins TA Technology (Shanghai) Co., Ltd.
Address: Building 3, No.145, Jintang Rd, Pudong Shanghai, P.R.China
City: Shanghai
Post code: 201201
Country: P. R. China
Contact: Xu Kai
Telephone: +86-021-50791141/2/3
Fax: +86-021-50791141/2/3-8000
Website: <https://www.eurofins.com/electrical-and-electronics>
E-mail: Kain.Xu@cpt.eurofinscn.com

2 General Description of Equipment under Test

2.1 Applicant and Manufacturer Information

Applicant	Positioning Universal Inc
Applicant address	4660 La Jolla Village Drive, Suite 1100, San Diego, CA92122, United States
Manufacturer	Positioning Universal Inc
Manufacturer address	4660 La Jolla Village Drive, Suite 1100, San Diego, CA92122, United States

2.2 General information

EUT Description			
Model	FJ1600LW		
Lab internal SN	R2406A0659/S01		
Hardware Version	P5.1		
Software Version	1.0		
Power Supply	Battery / Adapter		
Antenna Type	Internal Antenna		
Antenna Gain	LTE Band 4	2.0 dBi	
	LTE Band 12	0.0 dBi	
	LTE Band 13	0.0 dBi	
Test Mode(s)	LTE Band 4/12/13;		
Test Modulation	(LTE) QPSK, 16QAM;		
LTE Category	1		
Maximum E.I.R.P./ E.R.P.	LTE Band 4	23.98 dBm	
	LTE Band 12	19.92 dBm	
	LTE Band 13	19.60 dBm	
Rated Power Supply Voltage	12V		
Operating Voltage	Minimum: 6V Maximum: 32V		
Operating Temperature	Lowest: -30°C Highest: +75°C		
Testing Temperature	Lowest: -30°C Highest: +50°C		
Operating Frequency Range(s)	Mode	Tx (MHz)	Rx (MHz)
	LTE Band 4	1710 ~ 1755	2110 ~ 2155
	LTE Band 12	699 ~ 716	729 ~ 746
	LTE Band 13	777 ~ 787	746 ~ 756
EUT Accessory			
Battery	Manufacturer: Shenzhen Shenlan Aifa Technology Co., Ltd. Model: SL703048		

Auxiliary Test Equipment	
Adapter	Manufacturer: SHENZHEN AQUIL STAR TECHNOLOGY CO., LTD. Model: ASSA107A-120100
Note: 1. The EUT is sent from the applicant to Eurofins TA and the information of the EUT is declared by the applicant.	

3 Applied Standards

According to the specifications of the manufacturer, it must comply with the requirements of the following standards:

Test standards:

FCC CFR47 Part 27C (2023)

FCC CFR47 Part 2 (2023)

Reference standard:

ANSI C63.26-2015

KDB 971168 D01 Power Meas License Digital Systems v03r01

4 Test Configuration

Radiated measurements are performed by rotating the EUT in three different orthogonal test planes. EUT stand-up position (Z axis), lie-down position (X, Y axis). Receiver antenna polarization (horizontal and vertical), the worst emission was found in position (Y axis, horizontal polarization) and the worst case was recorded.

All mode and data rates and positions and RB size and modulations were investigated. Subsequently, only the worst case emissions are reported.

The following testing in LTE is set based on the maximum RF Output Power.

The following testing in different Bandwidth is set to detail in the following table:

Test modes are chosen to be reported as the worst case configuration below for LTE Band 4/12/13:

Test items	Modes	Bandwidth (MHz)						Modulation		RB			Test Channel		
		1.4	3	5	10	15	20	QPSK	16QAM	1	50%	100%	L	M	H
RF Power Output and Effective Isotropic Radiated Power	LTE 4	O	O	O	O	O	O	O	O	O	O	O	O	O	O
	LTE 12	O	O	O	O	-	-	O	O	O	O	O	O	O	O
	LTE 13	-	-	O	O	-	-	O	O	O	O	O	O	O	O
Radiated Spurious Emission	LTE 4	O	-	O	-	-	O	O	-	O	-	-	-	O	-
	LTE 12	O	-	O	O	-	-	O	-	O	-	-	-	O	-
	LTE 13	-	-	O	O	-	-	O	-	O	-	-	-	O	-
Note	1. The mark "O" means that this configuration is chosen for testing. 2. The mark "-" means that this configuration is not testing.														

5 Test Case

5.1 RF Power Output and Effective Isotropic Radiated Power

Ambient condition

Temperature	Relative humidity	Pressure
15°C ~ 35°C	20% ~ 80%	86 kPa ~ 106 kPa

Methods of Measurement

During the process of the testing, The EUT was connected to the Base Station Simulator with a known loss. The EUT is controlled by the Base Station Simulator test set to ensure max power transmission with proper modulation.

ERP can then be calculated as follows:

$EIRP \text{ (dBm)} = \text{Output Power (dBm)} + \text{Antenna Gain (dBi)}$

$EIRP \text{ (dBm)} = ERP \text{ (dBm)} + 2.15 \text{ (dB.)}$

Test Setup

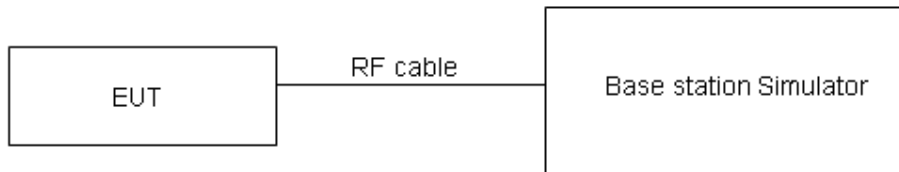

Limits

No specific RF power output requirements in part 2.1046.

Rule Part 27.50(b) (10) specifies that “Portable stations (hand-held devices) transmitting in the 746-757 MHz, 776-788 MHz, and 805-806 MHz bands are limited to 3 watts ERP”

Rule Part 27.50(c) (10) specifies that “Portable stations (hand-held devices) in the 600 MHz uplink band and the 698-746 MHz band, and fixed and mobile stations in the 600 MHz uplink band are limited to 3 watts ERP”

Rule Part 27.50(d) (4) specifies that “Fixed, mobile and portable (hand-held) stations operating in the 1710–1755 MHz band are limited to 1 watt EIRP”

Part 27.50(b)(10)Limit	$\leq 3 \text{ W}$ (34.77 dBm)
Part 27.50(c)(10)Limit	$\leq 3 \text{ W}$ (34.77 dBm)
Part 27.50(d)(4)Limit	$\leq 1 \text{ W}$ (30 dBm)

Measurement Uncertainty

The assessed measurement uncertainty to ensure 95% confidence level for the normal distribution is with the coverage factor $k = 2$, $U=0.4$ dB for RF power output, $k = 2$, $U= 1.19$ dB for ERP/EIRP.

Test Results

Refer to the section 6.1 of this report for test data.

5.2 Radiated Spurious Emission

Ambient condition

Temperature	Relative humidity	Pressure
15°C ~ 35°C	20% ~ 80%	86 kPa ~ 106 kPa

Method of Measurement

1. The testing follows FCC KDB 971168 D01 v03r01 Section 5.8 and ANSI C63.26-2015.
2. Below 1GHz: The EUT is placed on a turntable 0.8 meters above the ground in the chamber, 3 meter away from the antenna. The maximal emission value is acquired by adjusting the antenna height, polarisation and turntable azimuth. Normally, the height range of antenna is 1 m to 4 m, the azimuth range of turntable is 0° to 360°, and the receive antenna has two polarizations Vertical (V) and Horizontal (H). Above 1GHz: (Note: the FCC's permission to use 1.5m as an alternative per TCBC Conf call of Dec. 2, 2014.) The EUT is placed on a turntable 1.5 meters above the ground in the chamber, 3 meter away from the antenna. The maximal emission value is acquired by adjusting the antenna height, polarisation and turntable azimuth. Normally, the height range of antenna is 1 m to 4 m, the azimuth range of turntable is 0° to 360°, and the receive antenna has two polarizations Vertical (V) and Horizontal (H).
3. A loop antenna, A log-periodic antenna or horn antenna shall be substituted in place of the EUT. The log-periodic antenna will be driven by a signal generator and the level will be adjusted till the same power value on the spectrum analyzer or receiver. The level of the spurious emissions can be calculated through the level of the signal generator, cable loss, the gain of the substitution antenna and the reading of the spectrum analyzer or receiver.
4. The EUT is then put into continuously transmitting mode at its maximum power level during the test. Set Test Receiver or Spectrum RBW=100kHz, VBW=300kHz for 30MHz to 1GHz and RBW=1MHz, VBW=3MHz for above 1GHz, and the maximum value of the receiver should be recorded as (Pr).
5. The EUT shall be replaced by a substitution antenna. In the chamber, an substitution antenna for the frequency band of interest is placed at the reference point of the chamber. An RF Signal source for the frequency band of interest is connected to the substitution antenna with a cable that has been constructed to not interfere with the radiation pattern of the antenna. A power (PMea) is applied to the input of the substitution antenna, and adjust the level of the signal generator output until the value of the receiver reach the previously recorded (Pr). The power of signal source (PMea) is recorded. The test should be performed by rotating the test item and adjusting the receiving antenna polarization.
6. A amplifier should be connected to the Signal Source output port. And the cable should be connect between the Amplifier and the Substitution Antenna. The cable loss (Pcl) ,the Substitution Antenna Gain (Ga) and the Amplifier Gain (PAg) should be recorded after test.
7. The measurement results are obtained as described below:

$$\text{Power(EIRP)} = \text{PMea} - \text{PAg} - \text{Pcl} + \text{Ga}$$
 The measurement results are amend as described below:

$$\text{Power(EIRP)} = \text{PMea} - \text{Pcl} + \text{Ga}$$
8. This value is EIRP since the measurement is calibrated using an antenna of known gain (2.15 dB) and known input power. ERP can be calculated from EIRP by subtracting the gain of the dipole, $\text{ERP} = \text{EIRP} - 2.15\text{dB}$.

The modulation mode and RB allocation refer to section 5.1, using the maximum output power configuration.

Test setup

9KHz~ 30MHz

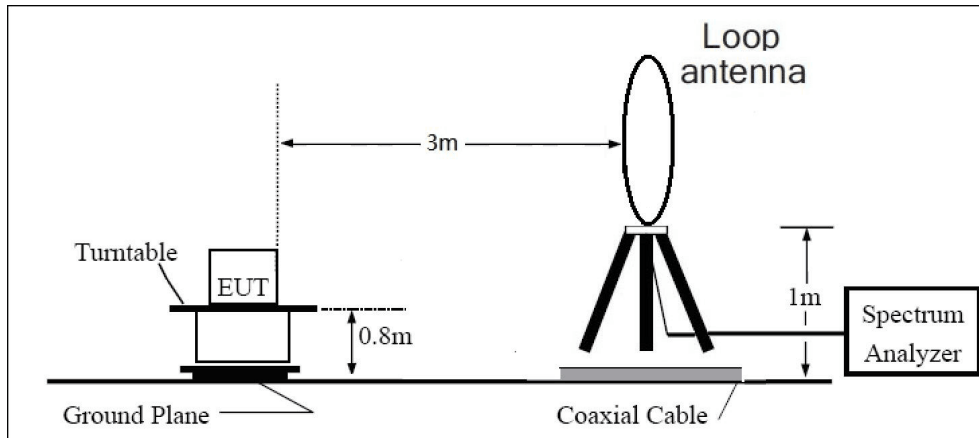

30MHz~ 1GHz

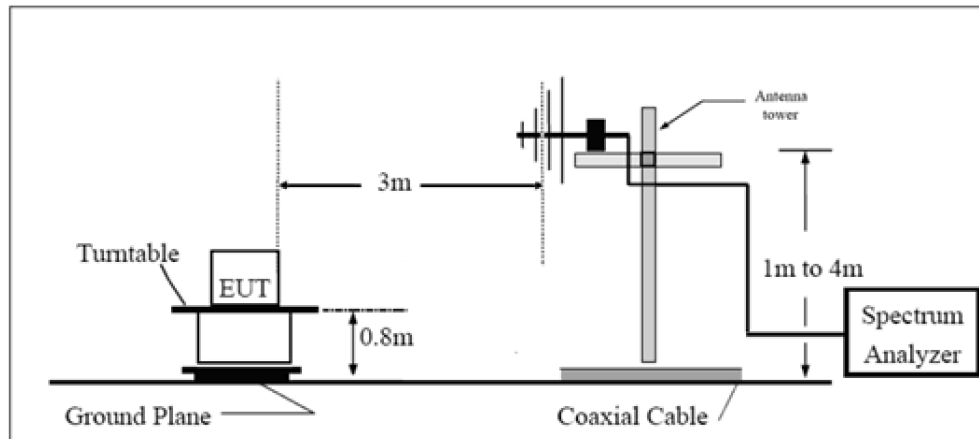

Above 1GHz

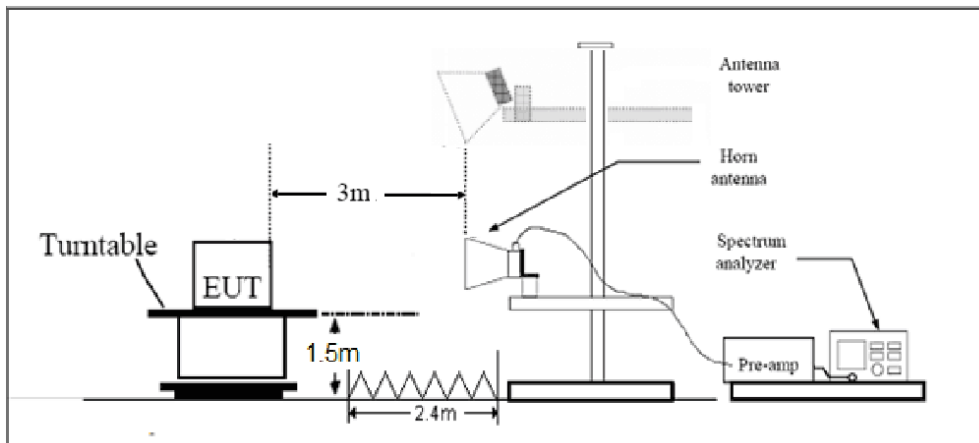

Note: Area side:2.4mX3.6m

Limits

Rule Part 27.53(h) specifies that “for operations in the 1695-1710 MHz, 1710-1755 MHz, 1755-1780 MHz, 1915-1920 MHz, 1995-2000 MHz, 2000-2020 MHz, 2110-2155 MHz, 2155-2180 MHz, and 2180-2200 bands, the power of any emission outside a licensee's frequency block shall be attenuated below the transmitter power (P) in watts by at least $43 + 10 \log_{10}(P)$ dB.”

Rule Part 27.53 (g) For operations in the 600 MHz band and the 698-746 MHz band, the power of any emission outside a licensee's frequency band(s) of operation shall be attenuated below the transmitter power (P) within the licensed band(s) of operation, measured in watts, by at least $43 + 10 \log(P)$ dB. Compliance with this provision is based on the use of measurement instrumentation employing a resolution bandwidth of 100 kilohertz or greater. However, in the 100 kilohertz bands immediately outside and adjacent to a licensee's frequency block, a resolution bandwidth of at least 30 kHz may be employed.

Rule Part 27.53(f) For operations in the 746-758 MHz, 775-788 MHz, and 805-806 MHz bands, emissions in the band 1559-1610 MHz shall be limited to -70 dBW/MHz equivalent isotropically radiated power (EIRP) for wideband signals, and -80 dBW EIRP for discrete emissions of less than 700 Hz bandwidth. For the purpose of equipment authorization, a transmitter shall be tested with an antenna that is representative of the type that will be used with the equipment in normal operation.

Part 27.53 (c) For operations in the 746-758 MHz band and the 776-788 MHz band, the power of any emission outside the licensee's frequency band(s) of operation shall be attenuated below the transmitter power (P) within the licensed band(s) of operation, measured in watts, in accordance with the following:

- (1) On any frequency outside the 746-758 MHz band, the power of any emission shall be attenuated outside the band below the transmitter power (P) by at least $43 + 10 \log(P)$ dB;
- (2) On any frequency outside the 776-788 MHz band, the power of any emission shall be attenuated outside the band below the transmitter power (P) by at least $43 + 10 \log(P)$ dB;
- (3) On all frequencies between 763-775 MHz and 793-805 MHz, by a factor not less than $76 + 10 \log(P)$ dB in a 6.25 kHz band segment, for base and fixed stations;
- (4) On all frequencies between 763-775 MHz and 793-805 MHz, by a factor not less than $65 + 10 \log(P)$ dB in a 6.25 kHz band segment, for mobile and portable stations;
- (5) Compliance with the provisions of paragraphs (c)(1) and (c)(2) of this section is based on the use of measurement instrumentation employing a resolution bandwidth of 100 kHz or greater. However, in the 100 kHz bands immediately outside and adjacent to the frequency block, a resolution bandwidth of at least 30 kHz may be employed;

Part 27.53 (h)/(g) Limit		-13 dBm
Part 27.53(f) Limit	Limit out of the band 1559-1610 MHz	-13 dBm
	Limit in the band 1559-1610 MHz	-40 dBm

Measurement Uncertainty

The assessed measurement uncertainty to ensure 95% confidence level for the normal distribution is with the coverage factor $k = \pm 1.96$, $U = \pm 3.55$ dB.

Test Results

Refer to the section 6.2 of this report for test data.

6 Test Results

6.1 RF Power Output and Effective Isotropic Radiated Power

LTE Band4						
Bandwidth (MHz)	UL Channel	RB Size	RB Position	Modulation	Power (dBm)	EIRP (dBm)
1.4	19957	1	#0	QPSK	21.58	23.58
1.4	19957	1	#Mid	QPSK	21.93	23.93
1.4	19957	1	#Max	QPSK	21.88	23.88
1.4	19957	3	#0	QPSK	21.59	23.59
1.4	19957	3	#Mid	QPSK	21.59	23.59
1.4	19957	3	#Max	QPSK	21.70	23.70
1.4	19957	6	#0	QPSK	20.48	22.48
1.4	20175	1	#0	QPSK	21.07	23.07
1.4	20175	1	#Mid	QPSK	21.24	23.24
1.4	20175	1	#Max	QPSK	21.03	23.03
1.4	20175	3	#0	QPSK	21.14	23.14
1.4	20175	3	#Mid	QPSK	21.13	23.13
1.4	20175	3	#Max	QPSK	21.11	23.11
1.4	20175	6	#0	QPSK	20.00	22.00
1.4	20393	1	#0	QPSK	21.63	23.63
1.4	20393	1	#Mid	QPSK	21.89	23.89
1.4	20393	1	#Max	QPSK	21.63	23.63
1.4	20393	3	#0	QPSK	21.46	23.46
1.4	20393	3	#Mid	QPSK	21.46	23.46
1.4	20393	3	#Max	QPSK	21.56	23.56
1.4	20393	6	#0	QPSK	20.58	22.58
3	19965	1	#0	QPSK	21.42	23.42
3	19965	1	#Mid	QPSK	21.56	23.56
3	19965	1	#Max	QPSK	21.70	23.70
3	19965	8	#0	QPSK	20.50	22.50
3	19965	8	#Mid	QPSK	20.51	22.51
3	19965	8	#Max	QPSK	20.59	22.59
3	19965	15	#0	QPSK	20.44	22.44
3	20175	1	#0	QPSK	21.23	23.23
3	20175	1	#Mid	QPSK	21.06	23.06
3	20175	1	#Max	QPSK	20.80	22.80
3	20175	8	#0	QPSK	20.14	22.14
3	20175	8	#Mid	QPSK	20.14	22.14
3	20175	8	#Max	QPSK	20.14	22.14

3	20175	15	#0	QPSK	20.01	22.01
3	20385	1	#0	QPSK	21.21	23.21
3	20385	1	#Mid	QPSK	21.54	23.54
3	20385	1	#Max	QPSK	21.70	23.70
3	20385	8	#0	QPSK	20.36	22.36
3	20385	8	#Mid	QPSK	20.38	22.38
3	20385	8	#Max	QPSK	20.62	22.62
3	20385	15	#0	QPSK	20.48	22.48
5	19975	1	#0	QPSK	21.55	23.55
5	19975	1	#Mid	QPSK	21.51	23.51
5	19975	1	#Max	QPSK	21.35	23.35
5	19975	12	#0	QPSK	20.50	22.50
5	19975	12	#Mid	QPSK	20.50	22.50
5	19975	12	#Max	QPSK	20.62	22.62
5	19975	25	#0	QPSK	20.52	22.52
5	20175	1	#0	QPSK	21.11	23.11
5	20175	1	#Mid	QPSK	20.95	22.95
5	20175	1	#Max	QPSK	20.86	22.86
5	20175	12	#0	QPSK	20.19	22.19
5	20175	12	#Mid	QPSK	20.19	22.19
5	20175	12	#Max	QPSK	19.96	21.96
5	20175	25	#0	QPSK	20.09	22.09
5	20375	1	#0	QPSK	21.23	23.23
5	20375	1	#Mid	QPSK	21.53	23.53
5	20375	1	#Max	QPSK	21.74	23.74
5	20375	12	#0	QPSK	20.27	22.27
5	20375	12	#Mid	QPSK	20.39	22.39
5	20375	12	#Max	QPSK	20.68	22.68
5	20375	25	#0	QPSK	20.50	22.50
10	20000	1	#0	QPSK	21.35	23.35
10	20000	1	#Mid	QPSK	21.56	23.56
10	20000	1	#Max	QPSK	21.44	23.44
10	20000	25	#0	QPSK	20.35	22.35
10	20000	25	#Mid	QPSK	20.36	22.36
10	20000	25	#Max	QPSK	20.45	22.45
10	20000	50	#0	QPSK	20.38	22.38
10	20175	1	#0	QPSK	20.95	22.95
10	20175	1	#Mid	QPSK	20.98	22.98
10	20175	1	#Max	QPSK	21.02	23.02
10	20175	25	#0	QPSK	20.08	22.08
10	20175	25	#Mid	QPSK	20.09	22.09
10	20175	25	#Max	QPSK	19.77	21.77
10	20175	50	#0	QPSK	19.88	21.88

10	20350	1	#0	QPSK	21.18	23.18
10	20350	1	#Mid	QPSK	21.85	23.85
10	20350	1	#Max	QPSK	21.59	23.59
10	20350	25	#0	QPSK	20.35	22.35
10	20350	25	#Mid	QPSK	20.35	22.35
10	20350	25	#Max	QPSK	20.35	22.35
10	20350	50	#0	QPSK	20.34	22.34
15	20025	1	#0	QPSK	21.31	23.31
15	20025	1	#Mid	QPSK	21.41	23.41
15	20025	1	#Max	QPSK	21.30	23.30
15	20025	36	#0	QPSK	20.32	22.32
15	20025	36	#Mid	QPSK	20.33	22.33
15	20025	36	#Max	QPSK	20.22	22.22
15	20025	75	#0	QPSK	20.21	22.21
15	20175	1	#0	QPSK	21.00	23.00
15	20175	1	#Mid	QPSK	21.09	23.09
15	20175	1	#Max	QPSK	20.98	22.98
15	20175	36	#0	QPSK	20.09	22.09
15	20175	36	#Mid	QPSK	20.07	22.07
15	20175	36	#Max	QPSK	19.81	21.81
15	20175	75	#0	QPSK	19.92	21.92
15	20325	1	#0	QPSK	21.32	23.32
15	20325	1	#Mid	QPSK	21.29	23.29
15	20325	1	#Max	QPSK	21.37	23.37
15	20325	36	#0	QPSK	20.27	22.27
15	20325	36	#Mid	QPSK	20.27	22.27
15	20325	36	#Max	QPSK	20.43	22.43
15	20325	75	#0	QPSK	20.33	22.33
20	20050	1	#0	QPSK	20.90	22.90
20	20050	1	#Mid	QPSK	21.49	23.49
20	20050	1	#Max	QPSK	20.95	22.95
20	20050	50	#0	QPSK	20.18	22.18
20	20050	50	#Mid	QPSK	20.18	22.18
20	20050	50	#Max	QPSK	20.23	22.23
20	20050	100	#0	QPSK	20.24	22.24
20	20175	1	#0	QPSK	21.27	23.27
20	20175	1	#Mid	QPSK	21.22	23.22
20	20175	1	#Max	QPSK	20.89	22.89
20	20175	50	#0	QPSK	20.00	22.00
20	20175	50	#Mid	QPSK	19.99	21.99
20	20175	50	#Max	QPSK	19.75	21.75
20	20175	100	#0	QPSK	19.85	21.85
20	20300	1	#0	QPSK	21.19	23.19

20	20300	1	#Mid	QPSK	21.49	23.49
20	20300	1	#Max	QPSK	21.40	23.40
20	20300	50	#0	QPSK	20.25	22.25
20	20300	50	#Mid	QPSK	20.25	22.25
20	20300	50	#Max	QPSK	20.29	22.29
20	20300	100	#0	QPSK	20.20	22.20
1.4	19957	1	#0	16QAM	20.72	22.72
1.4	19957	1	#Mid	16QAM	21.02	23.02
1.4	19957	1	#Max	16QAM	20.85	22.85
1.4	19957	3	#0	16QAM	20.62	22.62
1.4	19957	3	#Mid	16QAM	20.61	22.61
1.4	19957	3	#Max	16QAM	20.67	22.67
1.4	19957	6	#0	16QAM	19.37	21.37
1.4	20175	1	#0	16QAM	20.60	22.60
1.4	20175	1	#Mid	16QAM	20.58	22.58
1.4	20175	1	#Max	16QAM	20.38	22.38
1.4	20175	3	#0	16QAM	20.34	22.34
1.4	20175	3	#Mid	16QAM	20.33	22.33
1.4	20175	3	#Max	16QAM	20.34	22.34
1.4	20175	6	#0	16QAM	19.13	21.13
1.4	20393	1	#0	16QAM	20.29	22.29
1.4	20393	1	#Mid	16QAM	20.33	22.33
1.4	20393	1	#Max	16QAM	20.40	22.40
1.4	20393	3	#0	16QAM	20.75	22.75
1.4	20393	3	#Mid	16QAM	20.74	22.74
1.4	20393	3	#Max	16QAM	20.84	22.84
1.4	20393	6	#0	16QAM	19.74	21.74
3	19965	1	#0	16QAM	20.64	22.64
3	19965	1	#Mid	16QAM	21.03	23.03
3	19965	1	#Max	16QAM	21.07	23.07
3	19965	8	#0	16QAM	19.87	21.87
3	19965	8	#Mid	16QAM	19.87	21.87
3	19965	8	#Max	16QAM	20.24	22.24
3	19965	15	#0	16QAM	19.95	21.95
3	20175	1	#0	16QAM	21.15	23.15
3	20175	1	#Mid	16QAM	20.99	22.99
3	20175	1	#Max	16QAM	20.56	22.56
3	20175	8	#0	16QAM	19.66	21.66
3	20175	8	#Mid	16QAM	19.67	21.67
3	20175	8	#Max	16QAM	19.58	21.58
3	20175	15	#0	16QAM	19.47	21.47
3	20385	1	#0	16QAM	20.43	22.43
3	20385	1	#Mid	16QAM	20.69	22.69

3	20385	1	#Max	16QAM	20.88	22.88
3	20385	8	#0	16QAM	19.67	21.67
3	20385	8	#Mid	16QAM	19.68	21.68
3	20385	8	#Max	16QAM	20.03	22.03
3	20385	15	#0	16QAM	19.76	21.76
5	19975	1	#0	16QAM	20.70	22.70
5	19975	1	#Mid	16QAM	21.49	23.49
5	19975	1	#Max	16QAM	21.37	23.37
5	19975	12	#0	16QAM	19.80	21.80
5	19975	12	#Mid	16QAM	19.93	21.93
5	19975	12	#Max	16QAM	20.11	22.11
5	19975	25	#0	16QAM	20.00	22.00
5	20175	1	#0	16QAM	20.92	22.92
5	20175	1	#Mid	16QAM	21.07	23.07
5	20175	1	#Max	16QAM	20.75	22.75
5	20175	12	#0	16QAM	19.56	21.56
5	20175	12	#Mid	16QAM	19.56	21.56
5	20175	12	#Max	16QAM	19.22	21.22
5	20175	25	#0	16QAM	19.55	21.55
5	20375	1	#0	16QAM	20.60	22.60
5	20375	1	#Mid	16QAM	20.89	22.89
5	20375	1	#Max	16QAM	21.24	23.24
5	20375	12	#0	16QAM	19.73	21.73
5	20375	12	#Mid	16QAM	19.70	21.70
5	20375	12	#Max	16QAM	19.99	21.99
5	20375	25	#0	16QAM	19.80	21.80
10	20000	1	#0	16QAM	21.02	23.02
10	20000	1	#Mid	16QAM	21.94	23.94
10	20000	1	#Max	16QAM	21.24	23.24
10	20000	25	#0	16QAM	20.13	22.13
10	20000	25	#Mid	16QAM	20.12	22.12
10	20000	25	#Max	16QAM	20.24	22.24
10	20175	1	#0	16QAM	21.94	23.94
10	20175	1	#Mid	16QAM	21.68	23.68
10	20175	1	#Max	16QAM	21.16	23.16
10	20175	25	#0	16QAM	19.94	21.94
10	20175	25	#Mid	16QAM	19.95	21.95
10	20175	25	#Max	16QAM	19.42	21.42
10	20350	1	#0	16QAM	20.50	22.50
10	20350	1	#Mid	16QAM	21.29	23.29
10	20350	1	#Max	16QAM	20.89	22.89
10	20350	25	#0	16QAM	19.93	21.93
10	20350	25	#Mid	16QAM	19.94	21.94

10	20350	25	#Max	16QAM	20.11	22.11
15	20025	1	#0	16QAM	21.11	23.11
15	20025	1	#Mid	16QAM	21.98	23.98
15	20025	1	#Max	16QAM	21.15	23.15
15	20175	1	#0	16QAM	21.43	23.43
15	20175	1	#Mid	16QAM	20.92	22.92
15	20175	1	#Max	16QAM	21.24	23.24
15	20325	1	#0	16QAM	20.14	22.14
15	20325	1	#Mid	16QAM	20.87	22.87
15	20325	1	#Max	16QAM	20.46	22.46
20	20050	1	#0	16QAM	21.10	23.10
20	20050	1	#Mid	16QAM	21.84	23.84
20	20050	1	#Max	16QAM	20.50	22.50
20	20175	1	#0	16QAM	20.58	22.58
20	20175	1	#Mid	16QAM	20.42	22.42
20	20175	1	#Max	16QAM	19.63	21.63
20	20300	1	#0	16QAM	21.04	23.04
20	20300	1	#Mid	16QAM	21.06	23.06
20	20300	1	#Max	16QAM	21.13	23.13

LTE Band12						
Bandwidth (MHz)	UL Channel	RB Size	RB Position	Modulation	Power (dBm)	ERP (dBm)
1.4	23017	1	#0	QPSK	21.73	19.58
1.4	23017	1	#Mid	QPSK	21.48	19.33
1.4	23017	1	#Max	QPSK	21.39	19.24
1.4	23017	3	#0	QPSK	21.55	19.40
1.4	23017	3	#Mid	QPSK	21.54	19.39
1.4	23017	3	#Max	QPSK	21.53	19.38
1.4	23017	6	#0	QPSK	20.52	18.37
1.4	23095	1	#0	QPSK	21.42	19.27
1.4	23095	1	#Mid	QPSK	21.55	19.40
1.4	23095	1	#Max	QPSK	21.44	19.29
1.4	23095	3	#0	QPSK	21.32	19.17
1.4	23095	3	#Mid	QPSK	21.41	19.26
1.4	23095	3	#Max	QPSK	21.40	19.25
1.4	23095	6	#0	QPSK	20.54	18.39
1.4	23173	1	#0	QPSK	21.77	19.62
1.4	23173	1	#Mid	QPSK	21.79	19.64
1.4	23173	1	#Max	QPSK	21.72	19.57
1.4	23173	3	#0	QPSK	21.77	19.62
1.4	23173	3	#Mid	QPSK	21.75	19.60
1.4	23173	3	#Max	QPSK	21.66	19.51
1.4	23173	6	#0	QPSK	20.32	18.17
3	23025	1	#0	QPSK	21.59	19.44
3	23025	1	#Mid	QPSK	21.37	19.22
3	23025	1	#Max	QPSK	21.49	19.34
3	23025	8	#0	QPSK	20.53	18.38
3	23025	8	#Mid	QPSK	20.54	18.39
3	23025	8	#Max	QPSK	20.42	18.27
3	23025	15	#0	QPSK	20.44	18.29
3	23095	1	#0	QPSK	21.36	19.21
3	23095	1	#Mid	QPSK	21.40	19.25
3	23095	1	#Max	QPSK	21.35	19.20
3	23095	8	#0	QPSK	20.47	18.32
3	23095	8	#Mid	QPSK	20.48	18.33
3	23095	8	#Max	QPSK	20.56	18.41
3	23095	15	#0	QPSK	20.34	18.19
3	23165	1	#0	QPSK	21.46	19.31
3	23165	1	#Mid	QPSK	21.65	19.50
3	23165	1	#Max	QPSK	21.51	19.36
3	23165	8	#0	QPSK	20.40	18.25

3	23165	8	#Mid	QPSK	20.48	18.33
3	23165	8	#Max	QPSK	20.33	18.18
3	23165	15	#0	QPSK	20.44	18.29
5	23035	1	#0	QPSK	21.34	19.19
5	23035	1	#Mid	QPSK	21.30	19.15
5	23035	1	#Max	QPSK	21.52	19.37
5	23035	12	#0	QPSK	20.43	18.28
5	23035	12	#Mid	QPSK	20.44	18.29
5	23035	12	#Max	QPSK	20.52	18.37
5	23035	25	#0	QPSK	20.29	18.14
5	23095	1	#0	QPSK	21.22	19.07
5	23095	1	#Mid	QPSK	21.20	19.05
5	23095	1	#Max	QPSK	21.14	18.99
5	23095	12	#0	QPSK	20.46	18.31
5	23095	12	#Mid	QPSK	20.46	18.31
5	23095	12	#Max	QPSK	20.38	18.23
5	23095	25	#0	QPSK	20.21	18.06
5	23155	1	#0	QPSK	21.28	19.13
5	23155	1	#Mid	QPSK	21.51	19.36
5	23155	1	#Max	QPSK	21.34	19.19
5	23155	12	#0	QPSK	20.43	18.28
5	23155	12	#Mid	QPSK	20.43	18.28
5	23155	12	#Max	QPSK	20.53	18.38
5	23155	25	#0	QPSK	20.35	18.20
10	23060	1	#0	QPSK	21.44	19.29
10	23060	1	#Mid	QPSK	21.89	19.74
10	23060	1	#Max	QPSK	21.47	19.32
10	23060	25	#0	QPSK	20.44	18.29
10	23060	25	#Mid	QPSK	20.43	18.28
10	23060	25	#Max	QPSK	20.68	18.53
10	23060	50	#0	QPSK	20.46	18.31
10	23095	1	#0	QPSK	21.35	19.20
10	23095	1	#Mid	QPSK	21.75	19.60
10	23095	1	#Max	QPSK	21.36	19.21
10	23095	25	#0	QPSK	20.43	18.28
10	23095	25	#Mid	QPSK	20.45	18.30
10	23095	25	#Max	QPSK	20.43	18.28
10	23095	50	#0	QPSK	20.39	18.24
10	23130	1	#0	QPSK	21.47	19.32
10	23130	1	#Mid	QPSK	21.79	19.64
10	23130	1	#Max	QPSK	21.79	19.64
10	23130	25	#0	QPSK	20.30	18.15
10	23130	25	#Mid	QPSK	20.33	18.18

10	23130	25	#Max	QPSK	20.41	18.26
10	23130	50	#0	QPSK	20.31	18.16
1.4	23017	1	#0	16QAM	20.84	18.69
1.4	23017	1	#Mid	16QAM	21.06	18.91
1.4	23017	1	#Max	16QAM	20.88	18.73
1.4	23017	3	#0	16QAM	20.48	18.33
1.4	23017	3	#Mid	16QAM	20.48	18.33
1.4	23017	3	#Max	16QAM	20.55	18.40
1.4	23017	6	#0	16QAM	19.69	17.54
1.4	23095	1	#0	16QAM	20.70	18.55
1.4	23095	1	#Mid	16QAM	21.02	18.87
1.4	23095	1	#Max	16QAM	20.84	18.69
1.4	23095	3	#0	16QAM	20.60	18.45
1.4	23095	3	#Mid	16QAM	20.59	18.44
1.4	23095	3	#Max	16QAM	20.70	18.55
1.4	23095	6	#0	16QAM	19.42	17.27
1.4	23173	1	#0	16QAM	20.70	18.55
1.4	23173	1	#Mid	16QAM	20.65	18.50
1.4	23173	1	#Max	16QAM	20.57	18.42
1.4	23173	3	#0	16QAM	20.89	18.74
1.4	23173	3	#Mid	16QAM	20.87	18.72
1.4	23173	3	#Max	16QAM	20.56	18.41
1.4	23173	6	#0	16QAM	19.44	17.29
3	23025	1	#0	16QAM	20.65	18.50
3	23025	1	#Mid	16QAM	20.75	18.60
3	23025	1	#Max	16QAM	20.65	18.50
3	23025	8	#0	16QAM	19.61	17.46
3	23025	8	#Mid	16QAM	19.53	17.38
3	23025	8	#Max	16QAM	19.56	17.41
3	23025	15	#0	16QAM	19.63	17.48
3	23095	1	#0	16QAM	21.12	18.97
3	23095	1	#Mid	16QAM	21.20	19.05
3	23095	1	#Max	16QAM	21.12	18.97
3	23095	8	#0	16QAM	19.61	17.46
3	23095	8	#Mid	16QAM	19.61	17.46
3	23095	8	#Max	16QAM	19.85	17.70
3	23095	15	#0	16QAM	19.61	17.46
3	23165	1	#0	16QAM	20.54	18.39
3	23165	1	#Mid	16QAM	20.42	18.27
3	23165	1	#Max	16QAM	20.47	18.32
3	23165	8	#0	16QAM	19.66	17.51
3	23165	8	#Mid	16QAM	19.69	17.54
3	23165	8	#Max	16QAM	19.92	17.77

3	23165	15	#0	16QAM	19.68	17.53
5	23035	1	#0	16QAM	20.55	18.40
5	23035	1	#Mid	16QAM	20.56	18.41
5	23035	1	#Max	16QAM	20.74	18.59
5	23035	12	#0	16QAM	19.87	17.72
5	23035	12	#Mid	16QAM	19.79	17.64
5	23035	12	#Max	16QAM	19.87	17.72
5	23035	25	#0	16QAM	19.70	17.55
5	23095	1	#0	16QAM	20.47	18.32
5	23095	1	#Mid	16QAM	21.04	18.89
5	23095	1	#Max	16QAM	20.99	18.84
5	23095	12	#0	16QAM	19.48	17.33
5	23095	12	#Mid	16QAM	19.48	17.33
5	23095	12	#Max	16QAM	19.50	17.35
5	23095	25	#0	16QAM	19.73	17.58
5	23155	1	#0	16QAM	20.59	18.44
5	23155	1	#Mid	16QAM	20.66	18.51
5	23155	1	#Max	16QAM	20.72	18.57
5	23155	12	#0	16QAM	19.60	17.45
5	23155	12	#Mid	16QAM	19.68	17.53
5	23155	12	#Max	16QAM	19.86	17.71
5	23155	25	#0	16QAM	19.85	17.70
10	23060	1	#0	16QAM	20.93	18.78
10	23060	1	#Mid	16QAM	21.06	18.91
10	23060	1	#Max	16QAM	20.65	18.50
10	23060	25	#0	16QAM	19.83	17.68
10	23060	25	#Mid	16QAM	19.90	17.75
10	23060	25	#Max	16QAM	20.13	17.98
10	23095	1	#0	16QAM	21.24	19.09
10	23095	1	#Mid	16QAM	22.07	19.92
10	23095	1	#Max	16QAM	21.33	19.18
10	23095	25	#0	16QAM	19.74	17.59
10	23095	25	#Mid	16QAM	19.75	17.60
10	23095	25	#Max	16QAM	19.54	17.39
10	23130	1	#0	16QAM	20.23	18.08
10	23130	1	#Mid	16QAM	20.70	18.55
10	23130	1	#Max	16QAM	20.45	18.30
10	23130	25	#0	16QAM	19.85	17.70
10	23130	25	#Mid	16QAM	19.87	17.72
10	23130	25	#Max	16QAM	19.80	17.65

LTE Band13						
Bandwidth (MHz)	UL Channel	RB Size	RB Position	Modulation	Power (dBm)	ERP (dBm)
5	23205	1	#0	QPSK	21.36	19.21
5	23205	1	#Mid	QPSK	21.28	19.13
5	23205	1	#Max	QPSK	21.45	19.30
5	23205	12	#0	QPSK	20.54	18.39
5	23205	12	#Mid	QPSK	20.56	18.41
5	23205	12	#Max	QPSK	20.47	18.32
5	23205	25	#0	QPSK	20.43	18.28
5	23230	1	#0	QPSK	21.34	19.19
5	23230	1	#Mid	QPSK	21.70	19.55
5	23230	1	#Max	QPSK	21.49	19.34
5	23230	12	#0	QPSK	20.46	18.31
5	23230	12	#Mid	QPSK	20.44	18.29
5	23230	12	#Max	QPSK	20.65	18.50
5	23230	25	#0	QPSK	20.41	18.26
5	23255	1	#0	QPSK	21.42	19.27
5	23255	1	#Mid	QPSK	21.41	19.26
5	23255	1	#Max	QPSK	21.20	19.05
5	23255	12	#0	QPSK	20.62	18.47
5	23255	12	#Mid	QPSK	20.63	18.48
5	23255	12	#Max	QPSK	20.37	18.22
5	23255	25	#0	QPSK	20.41	18.26
10	23230	1	#0	QPSK	21.45	19.30
10	23230	1	#Mid	QPSK	21.75	19.60
10	23230	1	#Max	QPSK	21.28	19.13
10	23230	25	#0	QPSK	20.46	18.31
10	23230	25	#Mid	QPSK	20.44	18.29
10	23230	25	#Max	QPSK	20.49	18.34
10	23230	50	#0	QPSK	20.43	18.28
5	23205	1	#0	16QAM	20.90	18.75
5	23205	1	#Mid	16QAM	20.56	18.41
5	23205	1	#Max	16QAM	21.45	19.30
5	23205	12	#0	16QAM	19.91	17.76
5	23205	12	#Mid	16QAM	19.93	17.78
5	23205	12	#Max	16QAM	19.89	17.74
5	23205	25	#0	16QAM	20.03	17.88
5	23230	1	#0	16QAM	21.02	18.87
5	23230	1	#Mid	16QAM	21.38	19.23
5	23230	1	#Max	16QAM	21.32	19.17
5	23230	12	#0	16QAM	19.78	17.63

5	23230	12	#Mid	16QAM	19.76	17.61
5	23230	12	#Max	16QAM	19.80	17.65
5	23230	25	#0	16QAM	19.80	17.65
5	23255	1	#0	16QAM	20.95	18.80
5	23255	1	#Mid	16QAM	20.98	18.83
5	23255	1	#Max	16QAM	20.48	18.33
5	23255	12	#0	16QAM	19.95	17.80
5	23255	12	#Mid	16QAM	19.85	17.70
5	23255	12	#Max	16QAM	19.80	17.65
5	23255	25	#0	16QAM	19.93	17.78
10	23230	1	#0	16QAM	20.86	18.71
10	23230	1	#Mid	16QAM	21.24	19.09
10	23230	1	#Max	16QAM	20.34	18.19
10	23230	25	#0	16QAM	19.94	17.79
10	23230	25	#Mid	16QAM	20.01	17.86
10	23230	25	#Max	16QAM	19.91	17.76

6.2 Radiated Spurious Emission

Sweep the whole frequency band through the range from 9kHz to the 10th harmonic of the carrier, the emissions below the noise floor will not be recorded in the report.

LTE Band 4 QPSK 1.4MHz CH-Middle, RB 1

Harmonic	Frequency (MHz)	SG (dBm)	Cable Loss (dB)	Gain (dBi)	Antenna Polarization	EIRP Level (dBm)	Limit (dBm)	Margin (dB)	Azimuth (deg)
2	3463.60	-52.41	2.70	12.70	Horizontal	-42.41	-13.00	29.41	14
3	5195.40	-75.25	3.20	12.50	Horizontal	-65.95	-13.00	52.95	36
4	6927.20	-49.02	4.20	11.80	Horizontal	-41.42	-13.00	28.42	178
5	8659.00	-39.09	4.40	12.50	Horizontal	-30.99	-13.00	17.99	92
6	10390.80	-57.10	4.70	11.30	Horizontal	-50.50	-13.00	37.50	26
7	12122.60	-63.42	5.20	13.80	Horizontal	-54.82	-13.00	41.82	17
8	13854.40	-57.60	5.70	11.30	Horizontal	-52.00	-13.00	39.00	78
9	15586.20	-67.37	6.10	16.80	Horizontal	-56.67	-13.00	43.67	96
10	17318.00	-62.61	6.10	14.20	Horizontal	-54.51	-13.00	41.51	17

Note: 1. The other Spurious RF Radiated emissions level is no more than noise floor.
2. The worst emission was found in the antenna is Horizontal position.

LTE Band 4 QPSK 5MHz CH-Middle, RB 1

Harmonic	Frequency (MHz)	SG (dBm)	Cable Loss (dB)	Gain (dBi)	Antenna Polarization	EIRP Level (dBm)	Limit (dBm)	Margin (dB)	Azimuth (deg)
2	3460.00	-52.20	2.70	12.70	Horizontal	-42.20	-13.00	29.20	85
3	5190.00	-75.06	3.20	12.50	Horizontal	-65.76	-13.00	52.76	46
4	6920.00	-48.09	4.20	11.80	Horizontal	-40.49	-13.00	27.49	17
5	8650.00	-39.35	4.40	12.50	Horizontal	-31.25	-13.00	18.25	66
6	10380.00	-57.84	4.70	11.30	Horizontal	-51.24	-13.00	38.24	25
7	12110.00	-63.59	5.20	13.80	Horizontal	-54.99	-13.00	41.99	185
8	13840.00	-58.31	5.70	11.30	Horizontal	-52.71	-13.00	39.71	76
9	15570.00	-67.87	6.10	16.80	Horizontal	-57.17	-13.00	44.17	14
10	17300.00	-62.20	6.10	14.20	Horizontal	-54.10	-13.00	41.10	66

Note: 1. The other Spurious RF Radiated emissions level is no more than noise floor.
2. The worst emission was found in the antenna is Horizontal position.

LTE Band 4 QPSK 20MHz CH-Middle, RB 1

Harmonic	Frequency (MHz)	SG (dBm)	Cable Loss (dB)	Gain (dBi)	Antenna Polarization	EIRP Level (dBm)	Limit (dBm)	Margin (dB)	Azimuth (deg)
2	3445.00	-52.53	2.70	12.70	Horizontal	-42.53	-13.00	29.53	1
3	5167.50	-74.81	3.20	12.50	Horizontal	-65.51	-13.00	52.51	42
4	6890.00	-48.71	4.20	11.80	Horizontal	-41.11	-13.00	28.11	95
5	8612.50	-39.16	4.40	12.50	Horizontal	-31.06	-13.00	18.06	186
6	10335.00	-58.08	4.70	11.30	Horizontal	-51.48	-13.00	38.48	75
7	12057.50	-63.87	5.20	13.80	Horizontal	-55.27	-13.00	42.27	36
8	13780.00	-58.00	5.70	11.30	Horizontal	-52.40	-13.00	39.40	188
9	15502.50	-68.08	6.10	16.80	Horizontal	-57.38	-13.00	44.38	75
10	17225.00	-62.47	6.10	14.20	Horizontal	-54.37	-13.00	41.37	14

Note: 1. The other Spurious RF Radiated emissions level is no more than noise floor.
 2. The worst emission was found in the antenna is Horizontal position.

LTE Band 12 QPSK 1.4MHz CH-Middle, RB 1

Harmonic	Frequency (MHz)	SG (dBm)	Cable Loss (dB)	Gain (dBi)	Antenna Polarization	ERP Level (dBm)	Limit (dBm)	Margin (dB)	Azimuth (deg)
2	1413.60	-66.65	1.70	8.70	Horizontal	-61.80	-13.00	48.80	25
3	2120.40	-62.79	2.10	11.10	Horizontal	-55.94	-13.00	42.94	178
4	2827.20	-68.59	2.30	13.10	Horizontal	-59.94	-13.00	46.94	15
5	3537.50	-64.14	2.60	12.70	Horizontal	-56.19	-13.00	43.19	37
6	4245.00	-58.08	3.30	12.50	Horizontal	-51.03	-13.00	38.03	263
7	4952.50	-63.42	3.40	12.50	Horizontal	-56.47	-13.00	43.47	8
8	5660.00	-62.55	3.30	12.50	Horizontal	-55.50	-13.00	42.50	34
9	6367.50	-57.42	3.80	11.50	Horizontal	-51.87	-13.00	38.87	186
10	7075.00	-51.33	4.20	11.80	Horizontal	-45.88	-13.00	32.88	37

Note: 1. The other Spurious RF Radiated emissions level is no more than noise floor.
 2. The worst emission was found in the antenna is Horizontal position.

LTE Band 12 QPSK 5MHz CH-Middle, RB 1

Harmonic	Frequency (MHz)	SG (dBm)	Cable Loss (dB)	Gain (dBi)	Antenna Polarization	ERP Level (dBm)	Limit (dBm)	Margin (dB)	Azimuth (deg)
2	1410.60	-66.78	1.70	8.70	Horizontal	-61.93	-13.00	48.93	96
3	2115.90	-64.77	2.10	11.10	Horizontal	-57.92	-13.00	44.92	22
4	2820.00	-69.14	2.30	13.10	Horizontal	-60.49	-13.00	47.49	185
5	3525.00	-63.27	2.60	12.70	Horizontal	-55.32	-13.00	42.32	16
6	4230.00	-56.84	3.30	12.50	Horizontal	-49.79	-13.00	36.79	38
7	4935.00	-63.90	3.40	12.50	Horizontal	-56.95	-13.00	43.95	176
8	5640.00	-62.13	3.30	12.50	Horizontal	-55.08	-13.00	42.08	38
9	6345.00	-58.76	3.80	11.50	Horizontal	-53.21	-13.00	40.21	163
10	7050.00	-50.56	4.20	11.80	Horizontal	-45.11	-13.00	32.11	27

Note: 1.The other Spurious RF Radiated emissions level is no more than noise floor.
 2. The worst emission was found in the antenna is Horizontal position.

LTE Band 12 QPSK 10MHz CH-Middle, RB 1

Harmonic	Frequency (MHz)	SG (dBm)	Cable Loss (dB)	Gain (dBi)	Antenna Polarization	ERP Level (dBm)	Limit (dBm)	Margin (dB)	Azimuth (deg)
2	1405.00	-64.86	1.70	8.70	Horizontal	-60.01	-13.00	47.01	98
3	2107.50	-64.88	2.10	11.10	Horizontal	-58.03	-13.00	45.03	285
4	2810.00	-69.11	2.30	13.10	Horizontal	-60.46	-13.00	47.46	12
5	3512.50	-63.88	2.60	12.70	Horizontal	-55.93	-13.00	42.93	39
6	4215.00	-56.08	3.30	12.50	Horizontal	-49.03	-13.00	36.03	186
7	4917.50	-63.92	3.40	12.50	Horizontal	-56.97	-13.00	43.97	27
8	5620.00	-61.14	3.30	12.50	Horizontal	-54.09	-13.00	41.09	186
9	6322.50	-57.71	3.80	11.50	Horizontal	-52.16	-13.00	39.16	56
10	7025.00	-50.39	4.20	11.80	Horizontal	-44.94	-13.00	31.94	17

Note: 1.The other Spurious RF Radiated emissions level is no more than noise floor.
 2. The worst emission was found in the antenna is Horizontal position.

LTE Band 13 QPSK 5MHz CH-Middle, RB 1

Harmonic	Frequency (MHz)	SG (dBm)	Cable Loss (dB)	Gain (dBi)	Antenna Polarization	EIRP Level (dBm)	Limit (dBm)	Margin (dB)	Azimuth (deg)
2	1559.50	-67.59	1.70	8.70	Horizontal	-60.59	-40.00	20.59	22
Harmonic	Frequency (MHz)	SG (dBm)	Cable Loss (dB)	Gain (dBi)	Antenna Polarization	ERP Level (dBm)	Limit (dBm)	Margin (dB)	Azimuth (deg)
3	2339.24	-54.63	2.10	12.00	Horizontal	-46.88	-13.00	33.88	17
4	3118.00	-66.62	2.30	13.10	Horizontal	-57.97	-13.00	44.97	56
5	3897.50	-64.75	2.90	12.50	Horizontal	-57.30	-13.00	44.30	178
6	4677.00	-63.49	3.10	12.50	Horizontal	-56.24	-13.00	43.24	12
7	5456.50	-62.64	3.30	12.50	Horizontal	-55.59	-13.00	42.59	26
8	6236.00	-59.22	3.50	12.80	Horizontal	-52.07	-13.00	39.07	76
9	7015.50	-48.43	4.20	11.80	Horizontal	-42.98	-13.00	29.98	123
10	7795.00	-55.30	4.40	12.30	Horizontal	-49.55	-13.00	36.55	28

Note: 1. The other Spurious RF Radiated emissions level is no more than noise floor.
2. The worst emission was found in the antenna is Horizontal position.

LTE Band 13 QPSK 10MHz CH-Middle, RB 1

Harmonic	Frequency (MHz)	SG (dBm)	Cable Loss (dB)	Gain (dBi)	Antenna Polarization	EIRP Level (dBm)	Limit (dBm)	Margin (dB)	Azimuth (deg)
2	1580.73	-80.87	1.70	8.70	Horizontal	-73.87	-40.00	33.87	156
Harmonic	Frequency (MHz)	SG (dBm)	Cable Loss (dB)	Gain (dBi)	Antenna Polarization	ERP Level (dBm)	Limit (dBm)	Margin (dB)	Azimuth (deg)
3	2332.61	-56.41	2.10	12.00	Horizontal	-48.66	-13.00	35.66	78
4	3108.00	-67.18	2.30	13.10	Horizontal	-58.53	-13.00	45.53	186
5	3885.00	-64.89	2.90	12.50	Horizontal	-57.44	-13.00	44.44	17
6	4662.00	-64.25	3.10	12.50	Horizontal	-57.00	-13.00	44.00	46
7	5439.00	-62.32	3.30	12.50	Horizontal	-55.27	-13.00	42.27	38
8	6216.00	-59.90	3.50	12.80	Horizontal	-52.75	-13.00	39.75	37
9	6993.00	-59.12	4.20	11.80	Horizontal	-53.67	-13.00	40.67	175
10	7770.00	-55.45	4.40	12.30	Horizontal	-49.70	-13.00	36.70	26

Note: 1. The other Spurious RF Radiated emissions level is no more than noise floor.
2. The worst emission was found in the antenna is Horizontal position.

7 Main Test Instruments

Name	Manufacturer	Type	Serial Number	Calibration Date	Expiration Date
Wireless Communication Tester	Anritsu	MT8821C	6201538758	2024-05-08	2025-05-07
Wireless Communication Tester	R&S	CMW500	150415	2024-05-07	2025-05-06
Radiated Spurious Emission					
Spectrum Analyzer	R&S	FSV30	104028	2024-05-07	2025-05-06
High-pass filter	Chengyi	HPF 1000MHz	2024021	2024-02-21	2025-02-21
High-pass filter	R&S	HPF 1500MHz	HPF 002	2024-02-21	2025-02-21
High-pass filter	R&S	HPF 3000MHz	HPF 003	2024-02-21	2025-02-21
TRILOG Broadband Antenna	SCHWARZBECK	VULB 9163	391	2022-09-29	2025-09-28
Loop Antenna	SCHWARZBECK	FMZB1519	1519-047	2023-04-16	2026-04-15
Horn Antenna	SCHWARZBECK	BBHA 9120D	1594	2023-12-05	2026-12-04
Software	R&S	EMC32	10.35.10	/	/

ANNEX A: The EUT Appearance

The EUT Appearance are submitted separately.

ANNEX B: Test Setup Photos

The Test Setup Photos are submitted separately.

***** END OF REPORT *****