

RF TEST REPORT

Applicant	Positioning Universal Inc
FCC ID	2AHRH-FJ1600LW
Product	GPS TRACK
Brand	PUI
Model	FJ1600LW
Report No.	R2406A0659-R2
Issue Date	July 11, 2024

Eurofins TA Technology (Shanghai) Co., Ltd. tested the above equipment in accordance with the requirements in **FCC CFR47 Part 2 (2023)/ FCC CFR 47 Part 24E (2023)**. The test results show that the equipment tested is capable of demonstrating compliance with the requirements as documented in this report.

Prepared by: Xu Ying

Approved by: Xu Kai

Eurofins TA Technology (Shanghai) Co., Ltd.

Building 3, No.145, Jintang Rd, Pudong Shanghai, P.R.China

TEL: +86-021-50791141/2/3

FAX: +86-021-50791141/2/3-8000

TABLE OF CONTENT

1. Test Laboratory	4
1.1. Notes of the test report	4
1.2. Test facility	4
1.3. Testing Location	4
2. General Description of Equipment under Test	5
2.1. Applicant and Manufacturer Information	5
2.2. General information	5
3. Applied Standards	7
4. Test Configuration	8
5. Test Case	9
5.1. RF Power Output and Effective Isotropic Radiated Power	9
5.2. Radiated Spurious Emission	10
6. Test Results	13
6.1. RF Power Output and Effective Isotropic Radiated Power	13
6.2. Radiated Spurious Emission	26
7. Main Test Instruments	30
ANNEX A: The EUT Appearance	31
ANNEX B: Test Setup Photos	32

Summary of measurement results

No.	Test Case	Clause in FCC rules	Verdict
1	RF Power Output and Effective Isotropic Radiated Power	2.1046 24.232(c)	PASS
2	Radiated Spurious Emission	2.1053 / 24.238(a)	PASS
Date of Testing: June 26, 2024 ~ July 2, 2024 Date of Sample Received: June 18, 2024			
Note: PASS: The EUT complies with the essential requirements in the standard. FAIL: The EUT does not comply with the essential requirements in the standard. All indications of Pass/Fail in this report are opinions expressed by Eurofins TA Technology (Shanghai) Co., Ltd. based on interpretations and/or observations of test results. Measurement Uncertainties were not taken into account and are published for informational purposes only.			

Only RF Power Output and Radiated Spurious Emission is tested for FJ1600LW in this report, and Effective Isotropic Radiated Power also re-evaluated.

Other test items refer to the Module report (Report No.: TELI0004.0 Rev.4, FCC ID: R17LE910CXWWX).

1. Test Laboratory

1.1. Notes of the test report

This report shall not be reproduced in full or partial, without the written approval of **Eurofins TA Technology (Shanghai) Co., Ltd.** The results documented in this report apply only to the tested sample, under the conditions and modes of operation as described herein. Measurement Uncertainties were not taken into account and are published for informational purposes only. This report is written to support regulatory compliance of the applicable standards stated above.

1.2. Test facility

FCC (Designation number: CN1179, Test Firm Registration Number: 446626)

Eurofins TA Technology (Shanghai) Co., Ltd. has been listed on the US Federal Communications Commission list of test facilities recognized to perform measurements.

A2LA (Certificate Number: 3857.01)

Eurofins TA Technology (Shanghai) Co., Ltd. has been listed by American Association for Laboratory Accreditation to perform measurement.

1.3. Testing Location

Company: Eurofins TA Technology (Shanghai) Co., Ltd.
Address: Building 3, No.145, Jintang Rd, Pudong Shanghai, P.R.China
City: Shanghai
Post code: 201201
Country: P. R. China
Contact: Xu Kai
Telephone: +86-021-50791141/2/3
Fax: +86-021-50791141/2/3-8000
Website: <https://www.eurofins.com/electrical-and-electronics>
E-mail: Kain.Xu@cpt.eurofinscn.com

2. General Description of Equipment under Test

2.1.Applicant and Manufacturer Information

Applicant	Positioning Universal Inc
Applicant address	4660 La Jolla Village Drive, Suite 1100, San Diego, CA92122, United States
Manufacturer	Positioning Universal Inc
Manufacturer address	4660 La Jolla Village Drive, Suite 1100, San Diego, CA92122, United States

2.2.General information

EUT Description			
Model	FJ1600LW		
Lab internal SN	R2406A0659/S01		
Hardware Version	P5.1		
Software Version	1.0		
Power Supply	Battery / Adapter		
Antenna Type	Internal Antenna		
Antenna Gain	GSM 1900	2.6 dBi	
	LTE Band 2	2.6 dBi	
	LTE Band 25	2.6 dBi	
Test Mode(s)	GSM1900; LTE Band 2/25;		
Test Modulation	(GPRS)GMSK, (EGPRS) GMSK/ 8PSK; (LTE) QPSK, 16QAM;		
GPRS Multislot Class	12		
EGPRS Multislot Class	12		
LTE Category	1		
Maximum E.I.R.P	GSM 1900	31.98 dBm	
	LTE Band 2	24.48 dBm	
	LTE Band 25	23.80 dBm	
Rated Power Supply Voltage	12V		
Operating Voltage	Minimum: 6V Maximum: 32V		
Operating Temperature	Lowest: -30°C Highest: +75°C		
Testing Temperature	Lowest: -30°C Highest: +50°C		
Operating Frequency Range(s)	Band	Tx (MHz)	Rx (MHz)
	GSM1900	1850 ~ 1910	1930 ~ 1990
	LTE Band 2	1850 ~ 1910	1930 ~ 1990
	LTE Band 25	1850 ~ 1915	1930 ~ 1995
EUT Accessory			
Battery	Manufacturer: Shenzhen Shenlan Aifa Technology Co., Ltd. Model: SL703048		

Auxiliary Test Equipment	
Adapter	Manufacturer: SHENZHEN AQUIL STAR TECHNOLOGY CO., LTD. Model: ASSA107A-120100
Note: 1. The EUT is sent from the applicant to Eurofins TA and the information of the EUT is declared by the applicant.	

3. Applied Standards

According to the specifications of the manufacturer, it must comply with the requirements of the following standards:

Test standards:

FCC CFR 47 Part 24E (2023)

FCC CFR47 Part 2 (2023)

Reference standard:

ANSI C63.26-2015

KDB 971168 D01 Power Meas License Digital Systems v03r01

4. Test Configuration

Radiated measurements are performed by rotating the EUT in three different orthogonal test planes. EUT stand-up position (Z axis), lie-down position (X, Y axis). Receiver antenna polarization (horizontal and vertical), the worst emission was found in position (Z axis, horizontal polarization for GSM 1900 and Y axis, horizontal polarization for LTE Band 2/25) and the worst case was recorded.

All mode and data rates and positions and RB size and modulations were investigated. Subsequently, only the worst case emissions are reported.

The following testing in GSM/LTE is set based on the maximum RF Output Power.

Test modes are chosen to be reported as the worst case configuration below:

Test items	Modes/Modulation
	GSM 1900
RF Power Output and Effective Isotropic Radiated Power	GPRS EGPRS
Radiated Spurious Emission	GPRS

Test modes are chosen to be reported as the worst case configuration below for LTE Band 2/25:

Test items	Bandwidth (MHz)						Modulation		RB			Test Channel		
	1.4	3	5	10	15	20	QPSK	16QAM	1	50%	100%	L	M	H
RF Power Output and Effective Isotropic Radiated Power	O	O	O	O	O	O	O	O	O	O	O	O	O	O
Radiated Spurious Emission	O	-	O	-	-	O	O	-	O	-	-	-	O	-
Note	1. The mark "O" means that this configuration is chosen for testing. 2. The mark "-" means that this configuration is not testing.													

5. Test Case

5.1. RF Power Output and Effective Isotropic Radiated Power

Ambient condition

Temperature	Relative humidity	Pressure
15°C ~ 35°C	20% ~ 80%	86 kPa ~ 106 kPa

Methods of Measurement

During the process of the testing, The EUT was connected to the Base Station Simulator with a known loss. The EUT is controlled by the Base Station Simulator test set to ensure max power transmission with proper modulation.

ERP can then be calculated as follows:

$$\text{EIRP (dBm)} = \text{Output Power (dBm)} + \text{Antenna Gain (dBi)}$$

$$\text{EIRP (dBm)} = \text{ERP (dBm)} + 2.15 \text{ (dB.)}$$

Test Setup

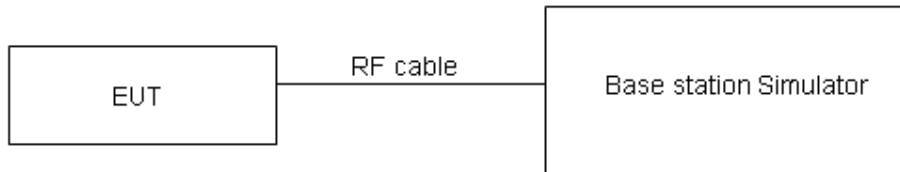

Limits

No specific RF power output requirements in part 2.1046.

Rule Part 24.232(c) Mobile and portable stations are limited to 2 watts EIRP.

Rule Part 24.232(e) Peak transmit power must be measured over any interval of continuous transmission using instrumentation calibrated in terms of an rms-equivalent voltage.

Limit	$\leq 2 \text{ W}$ (33 dBm)
-------	-----------------------------

Measurement Uncertainty

The assessed measurement uncertainty to ensure 95% confidence level for the normal distribution is with the coverage factor $k = 2$, $U = 0.4 \text{ dB}$ for RF power output, $k = 2$, $U = 1.19 \text{ dB}$ for EIRP.

Test Results

Refer to the section 6.1 of this report for test data.

5.2. Radiated Spurious Emission

Ambient condition

Temperature	Relative humidity	Pressure
15°C ~ 35°C	20% ~ 80%	86 kPa ~ 106 kPa

Method of Measurement

1. The testing follows FCC KDB 971168 v03r01 Section 5.8 and ANSI C63.26-2015.
2. Below 1GHz: The EUT is placed on a turntable 0.8 meters above the ground in the chamber, 3 meter away from the antenna. The maximal emission value is acquired by adjusting the antenna height, polarisation and turntable azimuth. Normally, the height range of antenna is 1 m to 4 m, the azimuth range of turntable is 0° to 360°, and the receive antenna has two polarizations Vertical (V) and Horizontal (H). Above 1GHz: (Note: the FCC's permission to use 1.5m as an alternative per TCBC Conf call of Dec. 2, 2014.) The EUT is placed on a turntable 1.5 meters above the ground in the chamber, 3 meter away from the antenna. The maximal emission value is acquired by adjusting the antenna height, polarisation and turntable azimuth. Normally, the height range of antenna is 1 m to 4 m, the azimuth range of turntable is 0° to 360°, and the receive antenna has two polarizations Vertical (V) and Horizontal (H).
3. A loop antenna, A log-periodic antenna or horn antenna shall be substituted in place of the EUT. The log-periodic antenna will be driven by a signal generator and the level will be adjusted till the same power value on the spectrum analyzer or receiver. The level of the spurious emissions can be calculated through the level of the signal generator, cable loss, the gain of the substitution antenna and the reading of the spectrum analyzer or receiver.
4. The EUT is then put into continuously transmitting mode at its maximum power level during the test. Set Test Receiver or Spectrum RBW=1MHz, VBW=3MHz, and the maximum value of the receiver should be recorded as (Pr).
5. The EUT shall be replaced by a substitution antenna. In the chamber, an substitution antenna for the frequency band of interest is placed at the reference point of the chamber. An RF Signal source for the frequency band of interest is connected to the substitution antenna with a cable that has been constructed to not interfere with the radiation pattern of the antenna. A power (PMea) is applied to the input of the substitution antenna, and adjust the level of the signal generator output until the value of the receiver reach the previously recorded (Pr). The power of signal source (PMea) is recorded. The test should be performed by rotating the test item and adjusting the receiving antenna polarization.
6. A amplifier should be connected to the Signal Source output port. And the cable should be connect between the Amplifier and the Substitution Antenna. The cable loss (Pcl) ,the Substitution Antenna Gain (Ga) and the Amplifier Gain (PAg) should be recorded after test.
7. The measurement results are obtained as described below:

$$\text{Power(EIRP)} = \text{PMea} - \text{PAg} - \text{Pcl} + \text{Ga}$$
 The measurement results are amend as described below:

$$\text{Power(EIRP)} = \text{PMea} - \text{Pcl} + \text{Ga}$$
8. This value is EIRP since the measurement is calibrated using an antenna of known gain (2.15 dB) and known input power. ERP can be calculated from EIRP by subtracting the gain of the dipole, $\text{ERP} = \text{EIRP} - 2.15\text{dB}$.

The modulation mode and RB allocation refer to section 5.1, using the maximum output power configuration.

Test setup

9KHz~ 30MHz

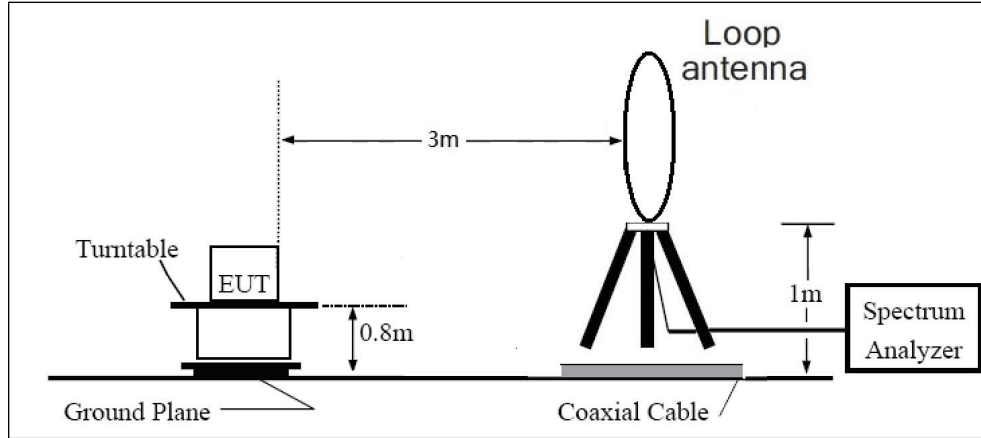

30MHz~ 1GHz

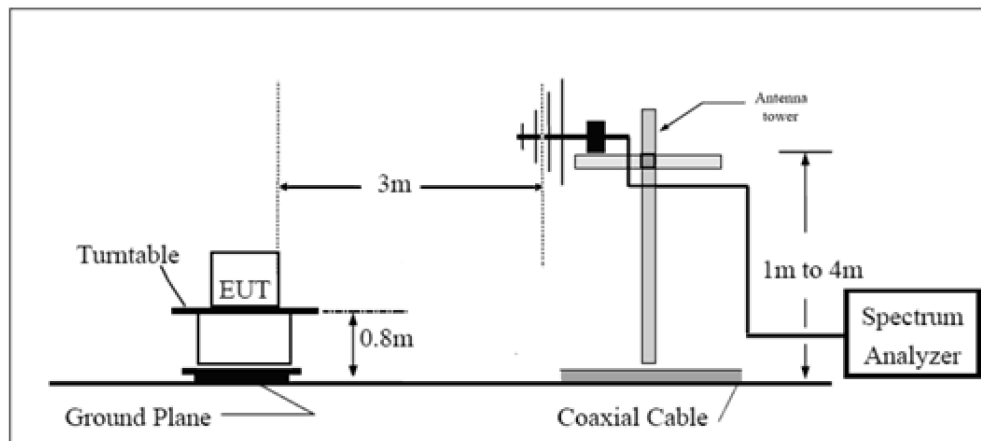

Above 1GHz

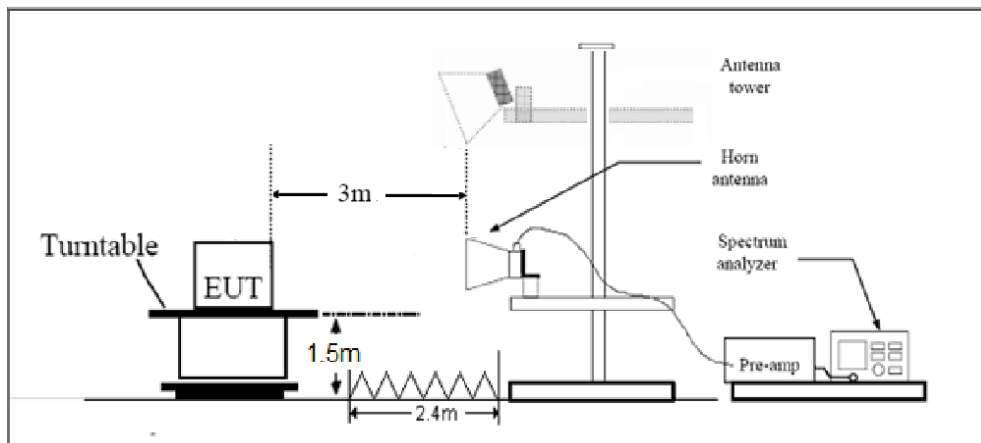

Note: Area side: 2.4mX3.6m

Limits

Rule Part 24.238(a) specifies that “on any frequency outside a licensee's frequency block, the power of any emission shall be attenuated below the transmitter power (P) by at least $43 + 10 \log_{10}(P)$ dB.”

Limit	-13 dBm
-------	---------

Measurement Uncertainty

The assessed measurement uncertainty to ensure 95% confidence level for the normal distribution is with the coverage factor $k = 1.96$, $U = 3.55$ dB.

Test Results

Refer to the section 6.2 of this report for test data.

6. Test Results

6.1. RF Power Output and Effective Isotropic Radiated Power

GSM 1900		Maximum Output Power (dBm)			EIRP (dBm)		
		Channel 512	Channel 661	Channel 810	Channel 512	Channel 661	Channel 810
		1850.2 (MHz)	1880 (MHz)	1909.8 (MHz)	1850.2 (MHz)	1880 (MHz)	1909.8 (MHz)
GPRS (GMSK)	1TXslot	29.19	29.37	29.38	31.79	31.97	31.98
	2TXslots	29.14	29.33	29.34	31.74	31.93	31.94
	3TXslots	29.17	29.27	29.29	31.77	31.87	31.89
	4TXslots	28.04	28.41	28.15	30.64	31.01	30.75
EGPRS (8PSK)	1TXslot	26.14	26.08	26.30	28.74	28.68	28.90
	2TXslots	26.05	26.01	26.10	28.65	28.61	28.70
	3TXslots	25.89	25.97	26.02	28.49	28.57	28.62
	4TXslots	25.78	25.86	25.87	28.38	28.46	28.47

LTE Band2						
Bandwidth (MHz)	UL Channel	RB Size	RB Position	Modulation	Power (dBm)	EIRP (dBm)
1.4	18607	1	#0	QPSK	21.88	24.48
1.4	18607	1	#Mid	QPSK	21.76	24.36
1.4	18607	1	#Max	QPSK	21.77	24.37
1.4	18607	3	#0	QPSK	21.57	24.17
1.4	18607	3	#Mid	QPSK	21.55	24.15
1.4	18607	3	#Max	QPSK	21.55	24.15
1.4	18607	6	#0	QPSK	20.41	23.01
1.4	18900	1	#0	QPSK	21.41	24.01
1.4	18900	1	#Mid	QPSK	21.49	24.09
1.4	18900	1	#Max	QPSK	21.37	23.97
1.4	18900	3	#0	QPSK	21.38	23.98
1.4	18900	3	#Mid	QPSK	21.37	23.97
1.4	18900	3	#Max	QPSK	21.47	24.07
1.4	18900	6	#0	QPSK	20.47	23.07
1.4	19193	1	#0	QPSK	20.96	23.56
1.4	19193	1	#Mid	QPSK	21.04	23.64
1.4	19193	1	#Max	QPSK	20.94	23.54
1.4	19193	3	#0	QPSK	20.98	23.58
1.4	19193	3	#Mid	QPSK	20.97	23.57
1.4	19193	3	#Max	QPSK	20.88	23.48
1.4	19193	6	#0	QPSK	19.98	22.58
3	18615	1	#0	QPSK	21.67	24.27
3	18615	1	#Mid	QPSK	21.40	24.00
3	18615	1	#Max	QPSK	21.48	24.08
3	18615	8	#0	QPSK	20.28	22.88
3	18615	8	#Mid	QPSK	20.29	22.89
3	18615	8	#Max	QPSK	20.39	22.99
3	18615	15	#0	QPSK	20.35	22.95
3	18900	1	#0	QPSK	21.33	23.93
3	18900	1	#Mid	QPSK	21.17	23.77
3	18900	1	#Max	QPSK	21.15	23.75
3	18900	8	#0	QPSK	20.46	23.06
3	18900	8	#Mid	QPSK	20.47	23.07
3	18900	8	#Max	QPSK	20.36	22.96
3	18900	15	#0	QPSK	20.34	22.94
3	19185	1	#0	QPSK	20.74	23.34
3	19185	1	#Mid	QPSK	20.79	23.39
3	19185	1	#Max	QPSK	20.86	23.46
3	19185	8	#0	QPSK	19.86	22.46

3	19185	8	#Mid	QPSK	19.86	22.46
3	19185	8	#Max	QPSK	19.92	22.52
3	19185	15	#0	QPSK	19.89	22.49
5	18625	1	#0	QPSK	21.19	23.79
5	18625	1	#Mid	QPSK	21.18	23.78
5	18625	1	#Max	QPSK	21.00	23.60
5	18625	12	#0	QPSK	20.32	22.92
5	18625	12	#Mid	QPSK	20.32	22.92
5	18625	12	#Max	QPSK	20.23	22.83
5	18625	25	#0	QPSK	20.23	22.83
5	18900	1	#0	QPSK	21.22	23.82
5	18900	1	#Mid	QPSK	21.19	23.79
5	18900	1	#Max	QPSK	20.85	23.45
5	18900	12	#0	QPSK	20.34	22.94
5	18900	12	#Mid	QPSK	20.35	22.95
5	18900	12	#Max	QPSK	20.14	22.74
5	18900	25	#0	QPSK	20.22	22.82
5	19175	1	#0	QPSK	20.76	23.36
5	19175	1	#Mid	QPSK	20.70	23.30
5	19175	1	#Max	QPSK	20.63	23.23
5	19175	12	#0	QPSK	19.79	22.39
5	19175	12	#Mid	QPSK	19.79	22.39
5	19175	12	#Max	QPSK	19.79	22.39
5	19175	25	#0	QPSK	19.70	22.30
10	18650	1	#0	QPSK	21.25	23.85
10	18650	1	#Mid	QPSK	21.13	23.73
10	18650	1	#Max	QPSK	20.99	23.59
10	18650	25	#0	QPSK	20.14	22.74
10	18650	25	#Mid	QPSK	20.13	22.73
10	18650	25	#Max	QPSK	20.09	22.69
10	18650	50	#0	QPSK	19.94	22.54
10	18900	1	#0	QPSK	21.16	23.76
10	18900	1	#Mid	QPSK	21.31	23.91
10	18900	1	#Max	QPSK	21.09	23.69
10	18900	25	#0	QPSK	20.38	22.98
10	18900	25	#Mid	QPSK	20.29	22.89
10	18900	25	#Max	QPSK	20.13	22.73
10	18900	50	#0	QPSK	20.34	22.94
10	19150	1	#0	QPSK	20.99	23.59
10	19150	1	#Mid	QPSK	20.90	23.50
10	19150	1	#Max	QPSK	20.76	23.36
10	19150	25	#0	QPSK	19.83	22.43
10	19150	25	#Mid	QPSK	19.83	22.43

10	19150	25	#Max	QPSK	19.83	22.43
10	19150	50	#0	QPSK	19.91	22.51
15	18675	1	#0	QPSK	21.15	23.75
15	18675	1	#Mid	QPSK	21.06	23.66
15	18675	1	#Max	QPSK	21.17	23.77
15	18675	36	#0	QPSK	19.89	22.49
15	18675	36	#Mid	QPSK	19.88	22.48
15	18675	36	#Max	QPSK	20.04	22.64
15	18675	75	#0	QPSK	19.91	22.51
15	18900	1	#0	QPSK	21.41	24.01
15	18900	1	#Mid	QPSK	21.08	23.68
15	18900	1	#Max	QPSK	21.02	23.62
15	18900	36	#0	QPSK	20.20	22.80
15	18900	36	#Mid	QPSK	20.21	22.81
15	18900	36	#Max	QPSK	20.04	22.64
15	18900	75	#0	QPSK	20.15	22.75
15	19125	1	#0	QPSK	20.86	23.46
15	19125	1	#Mid	QPSK	20.93	23.53
15	19125	1	#Max	QPSK	20.71	23.31
15	19125	36	#0	QPSK	19.87	22.47
15	19125	36	#Mid	QPSK	19.87	22.47
15	19125	36	#Max	QPSK	19.70	22.30
15	19125	75	#0	QPSK	19.88	22.48
20	18700	1	#0	QPSK	20.80	23.40
20	18700	1	#Mid	QPSK	21.33	23.93
20	18700	1	#Max	QPSK	20.71	23.31
20	18700	50	#0	QPSK	19.80	22.40
20	18700	50	#Mid	QPSK	19.79	22.39
20	18700	50	#Max	QPSK	20.05	22.65
20	18700	100	#0	QPSK	19.96	22.56
20	18900	1	#0	QPSK	21.51	24.11
20	18900	1	#Mid	QPSK	21.20	23.80
20	18900	1	#Max	QPSK	21.19	23.79
20	18900	50	#0	QPSK	20.20	22.80
20	18900	50	#Mid	QPSK	20.21	22.81
20	18900	50	#Max	QPSK	19.97	22.57
20	18900	100	#0	QPSK	20.06	22.66
20	19100	1	#0	QPSK	20.72	23.32
20	19100	1	#Mid	QPSK	21.06	23.66
20	19100	1	#Max	QPSK	20.74	23.34
20	19100	50	#0	QPSK	19.88	22.48
20	19100	50	#Mid	QPSK	19.82	22.42
20	19100	50	#Max	QPSK	19.70	22.30

20	19100	100	#0	QPSK	19.81	22.41
1.4	18607	1	#0	16QAM	20.56	23.16
1.4	18607	1	#Mid	16QAM	20.69	23.29
1.4	18607	1	#Max	16QAM	20.52	23.12
1.4	18607	3	#0	16QAM	20.40	23.00
1.4	18607	3	#Mid	16QAM	20.40	23.00
1.4	18607	3	#Max	16QAM	20.46	23.06
1.4	18607	6	#0	16QAM	19.16	21.76
1.4	18900	1	#0	16QAM	20.30	22.90
1.4	18900	1	#Mid	16QAM	20.78	23.38
1.4	18900	1	#Max	16QAM	20.58	23.18
1.4	18900	3	#0	16QAM	20.28	22.88
1.4	18900	3	#Mid	16QAM	20.15	22.75
1.4	18900	3	#Max	16QAM	20.14	22.74
1.4	18900	6	#0	16QAM	19.00	21.60
1.4	19193	1	#0	16QAM	19.67	22.27
1.4	19193	1	#Mid	16QAM	19.73	22.33
1.4	19193	1	#Max	16QAM	19.71	22.31
1.4	19193	3	#0	16QAM	19.88	22.48
1.4	19193	3	#Mid	16QAM	19.88	22.48
1.4	19193	3	#Max	16QAM	19.95	22.55
1.4	19193	6	#0	16QAM	19.04	21.64
3	18615	1	#0	16QAM	20.07	22.67
3	18615	1	#Mid	16QAM	20.53	23.13
3	18615	1	#Max	16QAM	20.43	23.03
3	18615	8	#0	16QAM	19.25	21.85
3	18615	8	#Mid	16QAM	19.23	21.83
3	18615	8	#Max	16QAM	19.24	21.84
3	18615	15	#0	16QAM	19.34	21.94
3	18900	1	#0	16QAM	20.59	23.19
3	18900	1	#Mid	16QAM	20.55	23.15
3	18900	1	#Max	16QAM	20.83	23.43
3	18900	8	#0	16QAM	19.76	22.36
3	18900	8	#Mid	16QAM	19.77	22.37
3	18900	8	#Max	16QAM	19.74	22.34
3	18900	15	#0	16QAM	19.74	22.34
3	19185	1	#0	16QAM	19.64	22.24
3	19185	1	#Mid	16QAM	19.65	22.25
3	19185	1	#Max	16QAM	19.50	22.10
3	19185	8	#0	16QAM	18.87	21.47
3	19185	8	#Mid	16QAM	18.87	21.47
3	19185	8	#Max	16QAM	18.94	21.54
3	19185	15	#0	16QAM	19.01	21.61

5	18625	1	#0	16QAM	20.60	23.20
5	18625	1	#Mid	16QAM	20.62	23.22
5	18625	1	#Max	16QAM	20.43	23.03
5	18625	12	#0	16QAM	19.69	22.29
5	18625	12	#Mid	16QAM	19.69	22.29
5	18625	12	#Max	16QAM	19.69	22.29
5	18625	25	#0	16QAM	19.80	22.40
5	18900	1	#0	16QAM	21.29	23.89
5	18900	1	#Mid	16QAM	21.20	23.80
5	18900	1	#Max	16QAM	20.93	23.53
5	18900	12	#0	16QAM	19.48	22.08
5	18900	12	#Mid	16QAM	19.39	21.99
5	18900	12	#Max	16QAM	19.44	22.04
5	18900	25	#0	16QAM	19.75	22.35
5	19175	1	#0	16QAM	20.16	22.76
5	19175	1	#Mid	16QAM	20.13	22.73
5	19175	1	#Max	16QAM	20.08	22.68
5	19175	12	#0	16QAM	19.12	21.72
5	19175	12	#Mid	16QAM	19.07	21.67
5	19175	12	#Max	16QAM	18.96	21.56
5	19175	25	#0	16QAM	19.14	21.74
10	18650	1	#0	16QAM	20.55	23.15
10	18650	1	#Mid	16QAM	20.42	23.02
10	18650	1	#Max	16QAM	19.96	22.56
10	18650	25	#0	16QAM	19.35	21.95
10	18650	25	#Mid	16QAM	19.43	22.03
10	18650	25	#Max	16QAM	19.34	21.94
10	18900	1	#0	16QAM	21.77	24.37
10	18900	1	#Mid	16QAM	21.66	24.26
10	18900	1	#Max	16QAM	20.95	23.55
10	18900	25	#0	16QAM	19.69	22.29
10	18900	25	#Mid	16QAM	19.62	22.22
10	18900	25	#Max	16QAM	19.31	21.91
10	19150	1	#0	16QAM	20.02	22.62
10	19150	1	#Mid	16QAM	20.07	22.67
10	19150	1	#Max	16QAM	19.62	22.22
10	19150	25	#0	16QAM	19.36	21.96
10	19150	25	#Mid	16QAM	19.36	21.96
10	19150	25	#Max	16QAM	19.14	21.74
15	18675	1	#0	16QAM	20.61	23.21
15	18675	1	#Mid	16QAM	20.45	23.05
15	18675	1	#Max	16QAM	20.49	23.09
15	18900	1	#0	16QAM	21.14	23.74

15	18900	1	#Mid	16QAM	20.80	23.40
15	18900	1	#Max	16QAM	21.02	23.62
15	19125	1	#0	16QAM	19.99	22.59
15	19125	1	#Mid	16QAM	20.06	22.66
15	19125	1	#Max	16QAM	18.98	21.58
20	18700	1	#0	16QAM	20.69	23.29
20	18700	1	#Mid	16QAM	21.04	23.64
20	18700	1	#Max	16QAM	20.38	22.98
20	18900	1	#0	16QAM	20.37	22.97
20	18900	1	#Mid	16QAM	20.16	22.76
20	18900	1	#Max	16QAM	19.60	22.20
20	19100	1	#0	16QAM	20.52	23.12
20	19100	1	#Mid	16QAM	20.87	23.47
20	19100	1	#Max	16QAM	20.20	22.80

LTE Band25						
Bandwidth (MHz)	UL Channel	RB Size	RB Position	Modulation	Power (dBm)	EIRP (dBm)
1.4	26047	1	#0	QPSK	21.06	23.66
1.4	26047	1	#Mid	QPSK	21.20	23.80
1.4	26047	1	#Max	QPSK	21.12	23.72
1.4	26047	3	#0	QPSK	20.93	23.53
1.4	26047	3	#Mid	QPSK	20.93	23.53
1.4	26047	3	#Max	QPSK	20.96	23.56
1.4	26047	6	#0	QPSK	19.83	22.43
1.4	26365	1	#0	QPSK	20.96	23.56
1.4	26365	1	#Mid	QPSK	21.05	23.65
1.4	26365	1	#Max	QPSK	20.98	23.58
1.4	26365	3	#0	QPSK	20.95	23.55
1.4	26365	3	#Mid	QPSK	20.95	23.55
1.4	26365	3	#Max	QPSK	20.96	23.56
1.4	26365	6	#0	QPSK	20.04	22.64
1.4	26683	1	#0	QPSK	20.52	23.12
1.4	26683	1	#Mid	QPSK	20.95	23.55
1.4	26683	1	#Max	QPSK	20.89	23.49
1.4	26683	3	#0	QPSK	20.56	23.16
1.4	26683	3	#Mid	QPSK	20.65	23.25
1.4	26683	3	#Max	QPSK	20.89	23.49
1.4	26683	6	#0	QPSK	19.54	22.14
3	26055	1	#0	QPSK	21.05	23.65
3	26055	1	#Mid	QPSK	20.70	23.30
3	26055	1	#Max	QPSK	20.76	23.36
3	26055	8	#0	QPSK	19.89	22.49
3	26055	8	#Mid	QPSK	19.90	22.50
3	26055	8	#Max	QPSK	19.94	22.54
3	26055	15	#0	QPSK	19.97	22.57
3	26365	1	#0	QPSK	20.99	23.59
3	26365	1	#Mid	QPSK	20.96	23.56
3	26365	1	#Max	QPSK	20.84	23.44
3	26365	8	#0	QPSK	20.08	22.68
3	26365	8	#Mid	QPSK	20.09	22.69
3	26365	8	#Max	QPSK	20.14	22.74
3	26365	15	#0	QPSK	20.10	22.70
3	26675	1	#0	QPSK	20.58	23.18
3	26675	1	#Mid	QPSK	20.68	23.28
3	26675	1	#Max	QPSK	20.73	23.33
3	26675	8	#0	QPSK	19.76	22.36

3	26675	8	#Mid	QPSK	19.78	22.38
3	26675	8	#Max	QPSK	19.68	22.28
3	26675	15	#0	QPSK	19.67	22.27
5	26065	1	#0	QPSK	20.89	23.49
5	26065	1	#Mid	QPSK	20.88	23.48
5	26065	1	#Max	QPSK	20.64	23.24
5	26065	12	#0	QPSK	19.84	22.44
5	26065	12	#Mid	QPSK	19.84	22.44
5	26065	12	#Max	QPSK	19.89	22.49
5	26065	25	#0	QPSK	19.83	22.43
5	26365	1	#0	QPSK	20.94	23.54
5	26365	1	#Mid	QPSK	20.89	23.49
5	26365	1	#Max	QPSK	20.76	23.36
5	26365	12	#0	QPSK	20.11	22.71
5	26365	12	#Mid	QPSK	20.12	22.72
5	26365	12	#Max	QPSK	20.07	22.67
5	26365	25	#0	QPSK	20.03	22.63
5	26665	1	#0	QPSK	20.52	23.12
5	26665	1	#Mid	QPSK	20.63	23.23
5	26665	1	#Max	QPSK	20.53	23.13
5	26665	12	#0	QPSK	19.64	22.24
5	26665	12	#Mid	QPSK	19.66	22.26
5	26665	12	#Max	QPSK	19.59	22.19
5	26665	25	#0	QPSK	19.62	22.22
10	26090	1	#0	QPSK	20.94	23.54
10	26090	1	#Mid	QPSK	20.92	23.52
10	26090	1	#Max	QPSK	20.71	23.31
10	26090	25	#0	QPSK	19.75	22.35
10	26090	25	#Mid	QPSK	19.75	22.35
10	26090	25	#Max	QPSK	19.91	22.51
10	26090	50	#0	QPSK	19.75	22.35
10	26365	1	#0	QPSK	20.84	23.44
10	26365	1	#Mid	QPSK	21.11	23.71
10	26365	1	#Max	QPSK	20.89	23.49
10	26365	25	#0	QPSK	20.13	22.73
10	26365	25	#Mid	QPSK	20.14	22.74
10	26365	25	#Max	QPSK	19.97	22.57
10	26365	50	#0	QPSK	20.04	22.64
10	26640	1	#0	QPSK	20.68	23.28
10	26640	1	#Mid	QPSK	21.03	23.63
10	26640	1	#Max	QPSK	20.72	23.32
10	26640	25	#0	QPSK	19.68	22.28
10	26640	25	#Mid	QPSK	19.70	22.30

10	26640	25	#Max	QPSK	19.64	22.24
10	26640	50	#0	QPSK	19.64	22.24
15	26115	1	#0	QPSK	20.72	23.32
15	26115	1	#Mid	QPSK	20.92	23.52
15	26115	1	#Max	QPSK	21.01	23.61
15	26115	36	#0	QPSK	19.87	22.47
15	26115	36	#Mid	QPSK	19.86	22.46
15	26115	36	#Max	QPSK	19.81	22.41
15	26115	75	#0	QPSK	19.77	22.37
15	26365	1	#0	QPSK	20.86	23.46
15	26365	1	#Mid	QPSK	21.02	23.62
15	26365	1	#Max	QPSK	20.90	23.50
15	26365	36	#0	QPSK	20.00	22.60
15	26365	36	#Mid	QPSK	20.01	22.61
15	26365	36	#Max	QPSK	20.04	22.64
15	26365	75	#0	QPSK	20.05	22.65
15	26615	1	#0	QPSK	20.31	22.91
15	26615	1	#Mid	QPSK	20.53	23.13
15	26615	1	#Max	QPSK	20.40	23.00
15	26615	36	#0	QPSK	19.51	22.11
15	26615	36	#Mid	QPSK	19.52	22.12
15	26615	36	#Max	QPSK	19.56	22.16
15	26615	75	#0	QPSK	19.51	22.11
20	26140	1	#0	QPSK	20.59	23.19
20	26140	1	#Mid	QPSK	20.98	23.58
20	26140	1	#Max	QPSK	20.30	22.90
20	26140	50	#0	QPSK	19.70	22.30
20	26140	50	#Mid	QPSK	19.69	22.29
20	26140	50	#Max	QPSK	19.74	22.34
20	26140	100	#0	QPSK	19.67	22.27
20	26365	1	#0	QPSK	21.06	23.66
20	26365	1	#Mid	QPSK	21.14	23.74
20	26365	1	#Max	QPSK	21.09	23.69
20	26365	50	#0	QPSK	19.94	22.54
20	26365	50	#Mid	QPSK	19.86	22.46
20	26365	50	#Max	QPSK	19.97	22.57
20	26365	100	#0	QPSK	19.94	22.54
20	26590	1	#0	QPSK	20.33	22.93
20	26590	1	#Mid	QPSK	20.66	23.26
20	26590	1	#Max	QPSK	20.40	23.00
20	26590	50	#0	QPSK	19.44	22.04
20	26590	50	#Mid	QPSK	19.45	22.05
20	26590	50	#Max	QPSK	19.60	22.20

20	26590	100	#0	QPSK	19.51	22.11
1.4	26047	1	#0	16QAM	20.53	23.13
1.4	26047	1	#Mid	16QAM	20.56	23.16
1.4	26047	1	#Max	16QAM	20.40	23.00
1.4	26047	3	#0	16QAM	20.16	22.76
1.4	26047	3	#Mid	16QAM	20.17	22.77
1.4	26047	3	#Max	16QAM	20.00	22.60
1.4	26047	6	#0	16QAM	19.20	21.80
1.4	26365	1	#0	16QAM	21.06	23.66
1.4	26365	1	#Mid	16QAM	21.15	23.75
1.4	26365	1	#Max	16QAM	21.09	23.69
1.4	26365	3	#0	16QAM	20.62	23.22
1.4	26365	3	#Mid	16QAM	20.62	23.22
1.4	26365	3	#Max	16QAM	20.55	23.15
1.4	26365	6	#0	16QAM	19.35	21.95
1.4	26683	1	#0	16QAM	19.13	21.73
1.4	26683	1	#Mid	16QAM	19.18	21.78
1.4	26683	1	#Max	16QAM	19.06	21.66
1.4	26683	3	#0	16QAM	19.78	22.38
1.4	26683	3	#Mid	16QAM	19.77	22.37
1.4	26683	3	#Max	16QAM	19.72	22.32
1.4	26683	6	#0	16QAM	18.74	21.34
3	26055	1	#0	16QAM	20.12	22.72
3	26055	1	#Mid	16QAM	20.28	22.88
3	26055	1	#Max	16QAM	20.32	22.92
3	26055	8	#0	16QAM	19.37	21.97
3	26055	8	#Mid	16QAM	19.37	21.97
3	26055	8	#Max	16QAM	19.21	21.81
3	26055	15	#0	16QAM	19.11	21.71
3	26365	1	#0	16QAM	20.87	23.47
3	26365	1	#Mid	16QAM	20.77	23.37
3	26365	1	#Max	16QAM	20.64	23.24
3	26365	8	#0	16QAM	19.67	22.27
3	26365	8	#Mid	16QAM	19.67	22.27
3	26365	8	#Max	16QAM	19.69	22.29
3	26365	15	#0	16QAM	19.56	22.16
3	26675	1	#0	16QAM	19.62	22.22
3	26675	1	#Mid	16QAM	19.56	22.16
3	26675	1	#Max	16QAM	19.50	22.10
3	26675	8	#0	16QAM	18.77	21.37
3	26675	8	#Mid	16QAM	18.79	21.39
3	26675	8	#Max	16QAM	18.81	21.41
3	26675	15	#0	16QAM	18.97	21.57

5	26065	1	#0	16QAM	20.15	22.75
5	26065	1	#Mid	16QAM	20.18	22.78
5	26065	1	#Max	16QAM	20.14	22.74
5	26065	12	#0	16QAM	19.13	21.73
5	26065	12	#Mid	16QAM	19.14	21.74
5	26065	12	#Max	16QAM	19.21	21.81
5	26065	25	#0	16QAM	19.27	21.87
5	26365	1	#0	16QAM	20.86	23.46
5	26365	1	#Mid	16QAM	20.76	23.36
5	26365	1	#Max	16QAM	20.69	23.29
5	26365	12	#0	16QAM	19.33	21.93
5	26365	12	#Mid	16QAM	19.35	21.95
5	26365	12	#Max	16QAM	19.23	21.83
5	26365	25	#0	16QAM	19.50	22.10
5	26665	1	#0	16QAM	19.90	22.50
5	26665	1	#Mid	16QAM	20.14	22.74
5	26665	1	#Max	16QAM	20.14	22.74
5	26665	12	#0	16QAM	18.83	21.43
5	26665	12	#Mid	16QAM	18.85	21.45
5	26665	12	#Max	16QAM	19.07	21.67
5	26665	25	#0	16QAM	18.93	21.53
10	26090	1	#0	16QAM	20.41	23.01
10	26090	1	#Mid	16QAM	20.56	23.16
10	26090	1	#Max	16QAM	20.09	22.69
10	26090	25	#0	16QAM	19.03	21.63
10	26090	25	#Mid	16QAM	19.03	21.63
10	26090	25	#Max	16QAM	19.17	21.77
10	26365	1	#0	16QAM	20.96	23.56
10	26365	1	#Mid	16QAM	21.09	23.69
10	26365	1	#Max	16QAM	21.16	23.76
10	26365	25	#0	16QAM	19.83	22.43
10	26365	25	#Mid	16QAM	19.82	22.42
10	26365	25	#Max	16QAM	19.77	22.37
10	26640	1	#0	16QAM	19.78	22.38
10	26640	1	#Mid	16QAM	19.97	22.57
10	26640	1	#Max	16QAM	19.81	22.41
10	26640	25	#0	16QAM	18.96	21.56
10	26640	25	#Mid	16QAM	19.15	21.75
10	26640	25	#Max	16QAM	19.37	21.97
15	26115	1	#0	16QAM	20.49	23.09
15	26115	1	#Mid	16QAM	20.31	22.91
15	26115	1	#Max	16QAM	20.42	23.02
15	26365	1	#0	16QAM	21.02	23.62

15	26365	1	#Mid	16QAM	21.15	23.75
15	26365	1	#Max	16QAM	21.06	23.66
15	26615	1	#0	16QAM	19.54	22.14
15	26615	1	#Mid	16QAM	19.63	22.23
15	26615	1	#Max	16QAM	19.31	21.91
20	26140	1	#0	16QAM	20.72	23.32
20	26140	1	#Mid	16QAM	20.99	23.59
20	26140	1	#Max	16QAM	20.35	22.95
20	26365	1	#0	16QAM	19.99	22.59
20	26365	1	#Mid	16QAM	20.13	22.73
20	26365	1	#Max	16QAM	19.92	22.52
20	26590	1	#0	16QAM	20.25	22.85
20	26590	1	#Mid	16QAM	20.34	22.94
20	26590	1	#Max	16QAM	20.15	22.75

6.2. Radiated Spurious Emission

Sweep the whole frequency band through the range from 9kHz to the 10th harmonic of the carrier, the emissions below the noise floor will not be recorded in the report.

GSM 1900 CH-Middle

Harmonic	Frequency (MHz)	SG (dBm)	Cable Loss (dB)	Gain (dBi)	Antenna Polarization	EIRP Level (dBm)	Limit (dBm)	Margin (dB)	Azimuth (deg)
2	3760.00	-47.66	2.60	12.50	Horizontal	-37.76	-13.00	24.76	93
3	5640.00	-59.12	3.30	12.50	Horizontal	-49.92	-13.00	36.92	26
4	7520.00	-50.42	4.20	12.20	Horizontal	-42.42	-13.00	29.42	185
5	9400.00	-52.10	4.30	11.10	Horizontal	-45.30	-13.00	32.30	14
6	11280.00	-49.26	5.90	11.90	Horizontal	-43.26	-13.00	30.26	25
7	13160.00	-52.52	5.70	14.00	Horizontal	-44.22	-13.00	31.22	76
8	15040.00	-51.71	5.80	13.10	Horizontal	-44.41	-13.00	31.41	175
9	16920.00	-52.71	6.10	14.60	Horizontal	-44.21	-13.00	31.21	21
10	18800.00	-	-	-	-	-	-	-	-

Note: 1. The other Spurious RF Radiated emissions level is no more than noise floor.
2. The worst emission was found in the antenna is Horizontal position.

LTE Band 2 1.4MHz CH-Middle

Harmonic	Frequency (MHz)	SG (dBm)	Cable Loss (dB)	Gain (dBi)	Antenna Polarization	EIRP Level (dBm)	Limit (dBm)	Margin (dB)	Azimuth (deg)
2	3759.00	-60.05	2.60	12.50	Horizontal	-50.15	-13.00	37.15	45
3	5638.88	-54.29	3.30	12.50	Horizontal	-45.09	-13.00	32.09	3
4	7520.00	-39.50	4.20	12.20	Horizontal	-31.50	-13.00	18.50	96
5	9400.00	-40.56	4.30	11.10	Horizontal	-33.76	-13.00	20.76	0
6	11280.00	-47.71	5.90	11.90	Horizontal	-41.71	-13.00	28.71	114
7	13160.00	-52.76	5.70	14.00	Horizontal	-44.46	-13.00	31.46	85
8	15040.00	-51.55	5.80	13.10	Horizontal	-44.25	-13.00	31.25	25
9	16920.00	-52.76	6.10	14.60	Horizontal	-44.26	-13.00	31.26	11
10	18800.00	-	-	-	-	-	-	-	-

Note: 1. The other Spurious RF Radiated emissions level is no more than noise floor.
2. The worst emission was found in the antenna is Horizontal position.

LTE Band 2 5MHz CH-Middle

Harmonic	Frequency (MHz)	SG (dBm)	Cable Loss (dB)	Gain (dBi)	Antenna Polarization	EIRP Level (dBm)	Limit (dBm)	Margin (dB)	Azimuth (deg)
2	3755.63	-60.31	2.60	12.50	Horizontal	-50.41	-13.00	37.41	28
3	5633.63	-55.05	3.30	12.50	Horizontal	-45.85	-13.00	32.85	174
4	7510.00	-38.26	4.20	12.20	Horizontal	-30.26	-13.00	17.26	76
5	9387.50	-40.46	4.30	11.10	Horizontal	-33.66	-13.00	20.66	56
6	11265.00	-47.11	5.90	11.90	Horizontal	-41.11	-13.00	28.11	78
7	13142.00	-51.45	5.70	14.00	Horizontal	-43.15	-13.00	30.15	185
8	15020.00	-51.14	5.80	13.10	Horizontal	-43.84	-13.00	30.84	36
9	16897.50	-52.22	6.10	14.60	Horizontal	-43.72	-13.00	30.72	11
10	18800.00	-	-	-	-	-	-	-	-

Note: 1. The other Spurious RF Radiated emissions level is no more than noise floor.
 2. The worst emission was found in the antenna is Horizontal position.

LTE Band 2 20MHz CH-Middle

Harmonic	Frequency (MHz)	SG (dBm)	Cable Loss (dB)	Gain (dBi)	Antenna Polarization	EIRP Level (dBm)	Limit (dBm)	Margin (dB)	Azimuth (deg)
2	3742.13	-58.49	2.60	12.50	Horizontal	-48.59	-13.00	35.59	46
3	5613.38	-57.04	3.30	12.50	Horizontal	-47.84	-13.00	34.84	25
4	7484.63	-39.71	4.20	12.20	Horizontal	-31.71	-13.00	18.71	178
5	9355.33	-42.87	4.30	11.10	Horizontal	-36.07	-13.00	23.07	36
6	11226.39	-50.25	5.90	11.90	Horizontal	-44.25	-13.00	31.25	18
7	13097.46	-52.63	5.70	14.00	Horizontal	-44.33	-13.00	31.33	26
8	14968.52	-51.87	5.80	13.10	Horizontal	-44.57	-13.00	31.57	175
9	16938.59	-53.44	6.10	14.60	Horizontal	-44.94	-13.00	31.94	25
10	18800.00	-	-	-	-	-	-	-	-

Note: 1. The other Spurious RF Radiated emissions level is no more than noise floor.
 2. The worst emission was found in the antenna is Horizontal position.

LTE Band 25 1.4MHz CH-Middle

Harmonic	Frequency (MHz)	SG (dBm)	Cable Loss (dB)	Gain (dBi)	Antenna Polarization	EIRP Level (dBm)	Limit (dBm)	Margin (dB)	Azimuth (deg)
2	3763.80	-59.43	2.60	12.50	Horizontal	-49.53	-13.00	36.53	189
3	5645.90	-54.13	3.30	12.50	Horizontal	-44.93	-13.00	31.93	76
4	7530.00	-37.90	4.20	12.20	Horizontal	-29.90	-13.00	16.90	40
5	9412.50	-41.32	4.30	11.10	Horizontal	-34.52	-13.00	21.52	275
6	11295.00	-49.75	5.90	11.90	Horizontal	-43.75	-13.00	30.75	263
7	13177.50	-52.47	5.70	14.00	Horizontal	-44.17	-13.00	31.17	101
8	15060.00	-52.13	5.80	13.10	Horizontal	-44.83	-13.00	31.83	2
9	16942.50	-52.31	6.10	14.60	Horizontal	-43.81	-13.00	30.81	251
10	18825.00	-	-	-	-	-	-	-	-

Note: 1. The other Spurious RF Radiated emissions level is no more than noise floor.
 2. The worst emission was found in the antenna is Horizontal position.

LTE Band 25 5MHz CH-Middle

Harmonic	Frequency (MHz)	SG (dBm)	Cable Loss (dB)	Gain (dBi)	Antenna Polarization	EIRP Level (dBm)	Limit (dBm)	Margin (dB)	Azimuth (deg)
2	3760.80	-60.01	2.60	12.50	Horizontal	-50.11	-13.00	37.11	31
3	5641.30	-55.47	3.30	12.50	Horizontal	-46.27	-13.00	33.27	64
4	7530.00	-39.20	4.20	12.20	Horizontal	-31.20	-13.00	18.20	215
5	9412.50	-42.37	4.30	11.10	Horizontal	-35.57	-13.00	22.57	255
6	11295.00	-50.84	5.90	11.90	Horizontal	-44.84	-13.00	31.84	312
7	13177.50	-51.82	5.70	14.00	Horizontal	-43.52	-13.00	30.52	182
8	15060.00	-52.04	5.80	13.10	Horizontal	-44.74	-13.00	31.74	3
9	16942.50	-51.55	6.10	14.60	Horizontal	-43.05	-13.00	30.05	0
10	18825.00	-	-	-	-	-	-	-	-

Note: 1. The other Spurious RF Radiated emissions level is no more than noise floor.
 2. The worst emission was found in the antenna is Horizontal position.

LTE Band 25 20MHz CH-Middle

Harmonic	Frequency (MHz)	SG (dBm)	Cable Loss (dB)	Gain (dBi)	Antenna Polarization	EIRP Level (dBm)	Limit (dBm)	Margin (dB)	Azimuth (deg)
2	3747.30	-58.48	2.60	12.50	Horizontal	-48.58	-13.00	35.58	245
3	5620.70	-56.17	3.30	12.50	Horizontal	-46.97	-13.00	33.97	220
4	7496.00	-39.19	4.20	12.20	Horizontal	-31.19	-13.00	18.19	84
5	9370.00	-41.81	4.30	11.10	Horizontal	-35.01	-13.00	22.01	295
6	11244.00	-50.77	5.90	11.90	Horizontal	-44.77	-13.00	31.77	0
7	13118.00	-52.26	5.70	14.00	Horizontal	-43.96	-13.00	30.96	309
8	14992.00	-50.85	5.80	13.10	Horizontal	-43.55	-13.00	30.55	295
9	16866.00	-52.52	6.10	14.60	Horizontal	-44.02	-13.00	31.02	0
10	18740.00	-	-	-	-	-	-	-	-

Note: 1. The other Spurious RF Radiated emissions level is no more than noise floor.
 2. The worst emission was found in the antenna is Horizontal position.

7. Main Test Instruments

Name	Manufacturer	Type	Serial Number	Calibration Date	Expiration Date
Wireless Communication Tester	Anritsu	MT8821C	6201538758	2024-05-08	2025-05-07
Wireless Communication Tester	R&S	CMW500	150415	2024-05-07	2025-05-06
Radiated Spurious Emission					
Spectrum Analyzer	R&S	FSV30	104028	2024-05-07	2025-05-06
High-pass filter	Chengyi	HPF 1000MHz	2024021	2024-02-21	2025-02-21
High-pass filter	R&S	HPF 1500MHz	HPF 002	2024-02-21	2025-02-21
High-pass filter	R&S	HPF 3000MHz	HPF 003	2024-02-21	2025-02-21
TRILOG Broadband Antenna	SCHWARZBECK	VULB 9163	391	2022-09-29	2025-09-28
Loop Antenna	SCHWARZBECK	FMZB1519	1519-047	2023-04-16	2026-04-15
Horn Antenna	SCHWARZBECK	BBHA 9120D	1594	2023-12-05	2026-12-04
Horn Antenna	ETS-Lindgren	3160-09	00102643	2021-10-10	2024-10-09
Software	R&S	EMC32	10.35.10	/	/

ANNEX A: The EUT Appearance

The EUT Appearance is submitted separately.

ANNEX B: Test Setup Photos

The Test Setup Photos is submitted separately.

***** END OF REPORT *****