

FJ1000LS User Manual

Positioning Universal

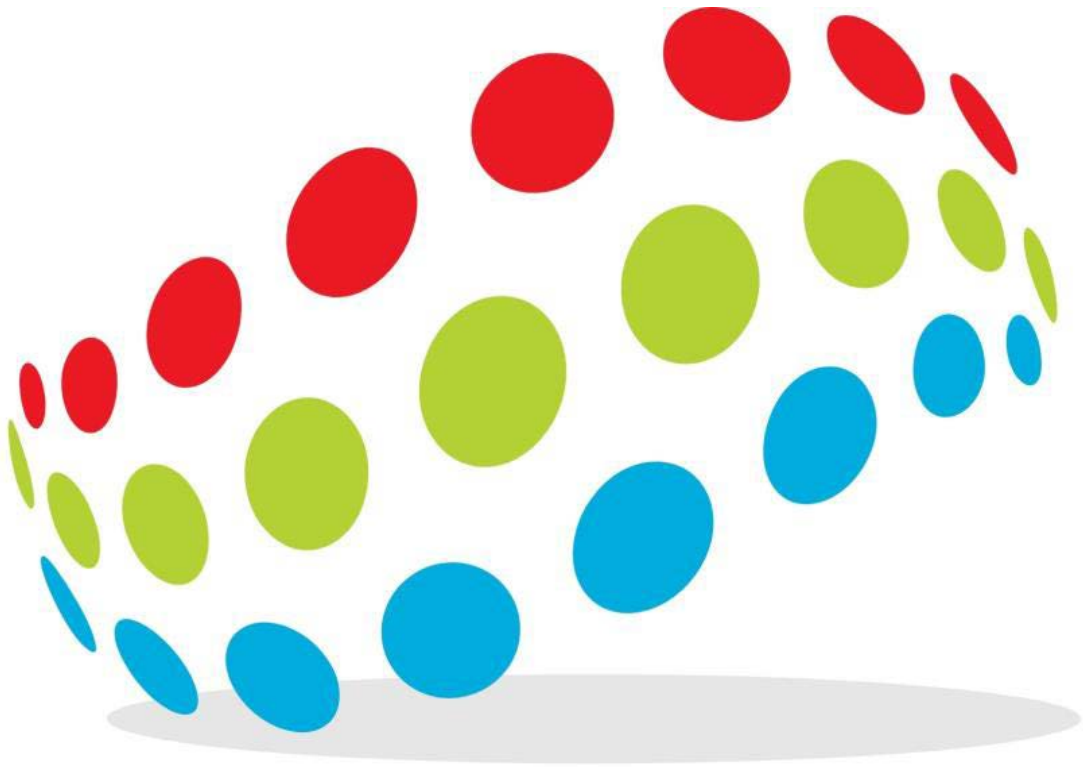

Contents

1 Introduction3
1.1 ID and Tooling Design.....3

2 Hardware.....3
2.1 Physical and Electrical Specifications3
2.2 Input/Output.....3
2.3 Cellular Communication.....3
2.4
Harnesses.....3
2.5 Event Codes4
2.6 System network structure.....5
2.7 Appearance and installation instructions.....5

3 USER MANUAL.....6
3.1 INTRODUCTION.....6
3.2 List.....6
3.3 Description.....7

1.1 ID and Tooling Design

Dimensions: 80.5mm*52mm*18mm

Weight: 60g (with optional battery)

2.1 Physical and Electrical Specifications

Input Voltage: 7-30VDC

Power consumption:

- Active mode: 100mA @ 12VDC

- Sleep mode: <8mA @ 12VDC

Operating temperature: -30°C to 80°C

Storage temperature: -40°C to 85°C

2.2 Input/Output

Download and debug port: 1

SWD Interface: 1

Function LEDs: 2

2.3 Cellular Communication

Operation mode : LTE/GPS

Operation band : LTEB12/B25/B26;GPS 1.57542GHz

Modulation: QPSK/16QAM

2.4 Harnesses

There are 3 harnesses that may be used with the FJ1000LS:

1. 4 wire power and I/O harness
2. 4 wire uart
3. 14 wire power and I/O harness

The picture as below.

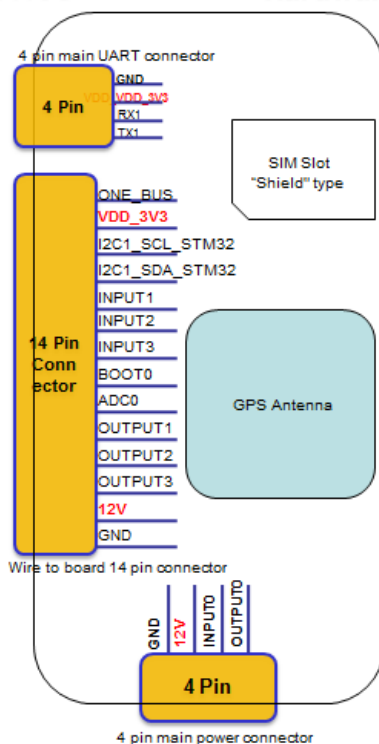

2.5 Event Codes

The table below relates the Event codes in the message to the reason the message was generated:

Message #	Message Type	Description
0	Interval	Auto Report (auto report when moving)
1	Vibration	Vibration alarm(report when GPS is OFF and vibration detected)
2	Power Disconnect	Power cut alarm (report when external power is cut off)
3	Power Connect	Power connected alarm (external power has been connected)
4	Ignition ON	Hardwired or Virtual Ignition ON detected
5	Ignition OFF	Hardwired or Virtual Ignition OFF detected
6	Input 2 High	Input2 high alarm
7	Input 2 Low	Input2 low alarm
8		
9		
10		
11		
12		

2.6 System network structure

GPS alarm is currently the most advanced security Settings. GPS alarm more expensive than ordinary burglar alarm, and need to pay the additional service fee, so the popularity is not high. And alarm is based on a GPRS network communication network, combining with the intelligent linkage of mobile phone and car anti-theft, this kind of alarm alarm is not restricted by distance, overlay network is wide, but need to pay the monthly rental. Buying guide to edit GPS alarm when the choose and buy, need to pay attention to is the comparison of several common GPS performance.

2.7 Appearance and installation instructions



3.1 Introduction.

This chapter is user manual for FJ1000LS.

3.2List.

1. One UART cables.



2. The FJ1000LS devices.





3. One DC 12V cable.



3.3 Description.

1. Connect the UART cable to the UART interface of MCU on the device, the other side connect to PC, you can communication to MCU with UART cable.

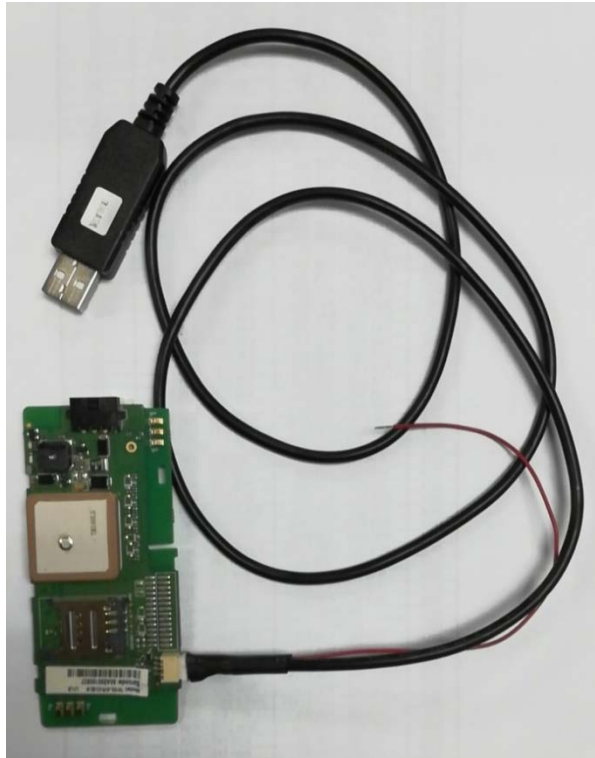

2. Connect the DC 12V cable to the connector of J203 on the device, the other side connect to DC 12V, you can use the DC 12v cable to supply power.

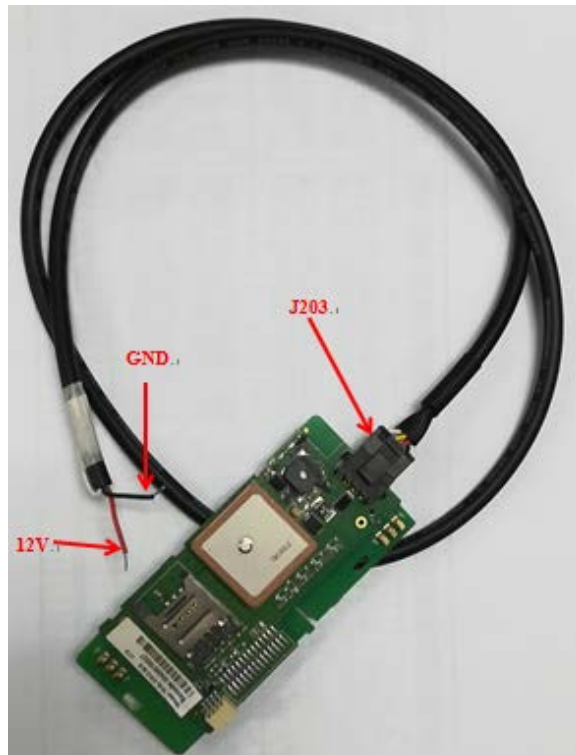

4. The other interfaces of the FJ1000LS device are shown in the following pictures.(The Modem UART 1 on device is for modem debug and update firmware).

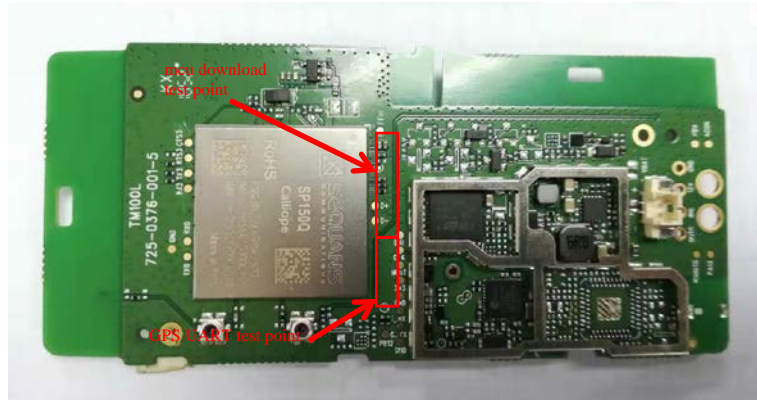

NOTE: This equipment has been tested and found to comply with the limits for a Class B digital device, pursuant to part 15 of the FCC Rules. These limits are designed to provide reasonable protection against harmful interference in a residential installation. This equipment generates, uses and can radiate radio frequency energy and, if not installed and used in accordance with the instructions, may cause harmful interference to radio communications. However, there is no guarantee that interference will not occur in a particular installation. If this equipment does cause harmful interference to radio or television reception, which can be determined by turning the equipment off and on, the user is encouraged to try to correct the interference by one or more of the following measures:

- Reorient or relocate the receiving antenna
- Increase the separation between the equipment and receiver.
- Connect the equipment into an outlet on a circuit different from that to which the receiver is connected.
- Consult the dealer or an experienced radio/TV technician for help.

This device complies with part 15 of the FCC Rules. Operation is subject to the following two conditions: (1) This device may not cause harmful interference, and (2) this device must accept any interference received, including interference that may cause undesired operation.

Changes or modifications not expressly approved by the party responsible for compliance could void the user's authority to operate the equipment.

Keep at least 20cm away from the unit when it works.