

ZigBee Module Instruction manual

Version: 20220918

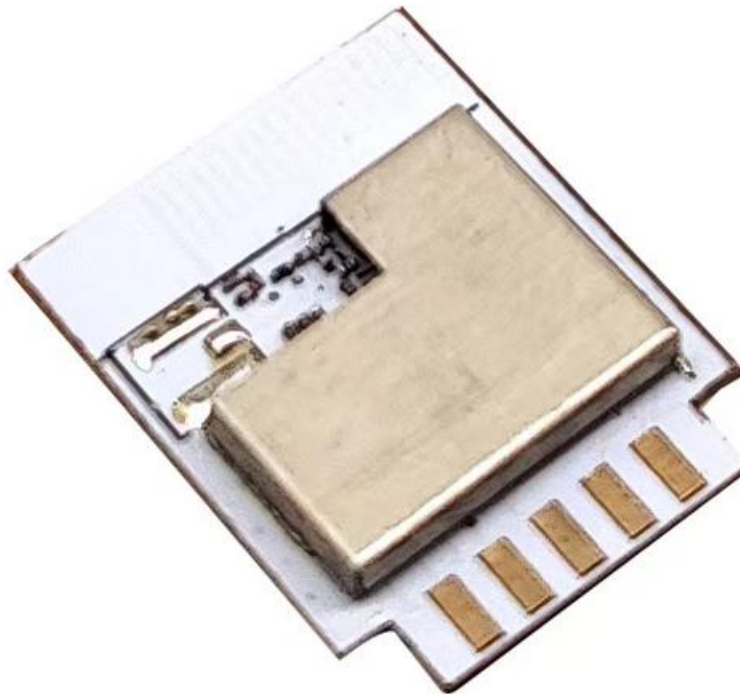

Contents

I Overview	2
1.1 Features.....	2
1.2 Applications.....	2
1.3 Change history.....	2
2 Module interfaces	4
2.1 Dimensions and package	4
2.2 Pin definition.....	5
3 Electrical parameters	9
3.1 Absolute electrical parameters.....	9
3.2 Normal working conditions	9
3.3 TX and RX power consumption	10
3.4 Operating current.....	10
4 RF parameters	12
4.1 Basic RF features	12
4.2 TX performance	12
4.3 RX performance	13
5 Requirements on power-on sequence	14
6 Antenna	16
6.1 Antenna type	16
6.2 Antenna interference reduction	16
7 Packaging information and production instructions	17
7.1 Mechanical dimensions	17
7.2 Side view.....	19
7.3 The schematic diagram of footprint.....	20
7.4 Diagram of PCB footprint	20
7.5 Production instructions	21
7.6 Recommended oven temperature curve	23
7.7 Storage conditions.....	26
8 MOQ and packaging information	27
9 Appendix: Statement	28

ZTU-ZB02 is a Zigbee module that Milfra has developed. It consists of a highly integrated RF chip (RT582), and a few peripherals. ZTU-ZB02 is embedded with ARM® Cortex® -M3 CPU, internal MCU for MAC, Boot ROM, 208KB SRAM total (CPU + MCU), and rich peripheral resources.

I Overview

Based on ZTU-ZB02, you can develop Zigbee products as required.

I.1 Features

- Embedded with a low-power 32-bit CPU processor
- The maximum clock rate: 48 MHz
- Wide operating voltage: 1.8 to 3.6 V (2.8V or higher is recommended)
- Peripherals: 17 general-purpose input/output (GPIO), 3 universal asynchronous receiver/transmitter (UART), and 4 analog-to-digital converters (ADC)
- Zigbee connectivity
 - Support 802.15.4 MAC/PHY
 - Working channels 11 to 26 @2.400 to 2.483 GHz, air interface rate: 250 Kbps
 - Up to +10dBm output power and dynamic output power >35 dB
 - Built-in onboard PCB antenna, IpeX connector reserved
 - Onboard PCB antenna with a gain of 1.0dBi
 - Operating temperature: -40°C to 105°C
 - Support hardware encryption and AES 128

I.2 Applications

- Intelligent building
- Smart household and home appliances
- Smart socket and light
- Industrial wireless control
- Baby monitor
- Intelligent bus

I.3 Change history

Update date	Updated content	Version after update
09/18/2022	This is the first release.	V1.0.0
		V1.0.1

2 Module interfaces

2.1 Dimensions and package

ZTU-ZB02 has 3 rows of pins with a 1.4 ± 0.1 mm pin spacing.

The ZTU-ZB02 dimensions are 20.3 ± 0.35 mm (L) \times 15.8 ± 0.35 mm (W) \times 3 ± 0.15 mm (H). The dimensions of ZTU-ZB02 are as follows:

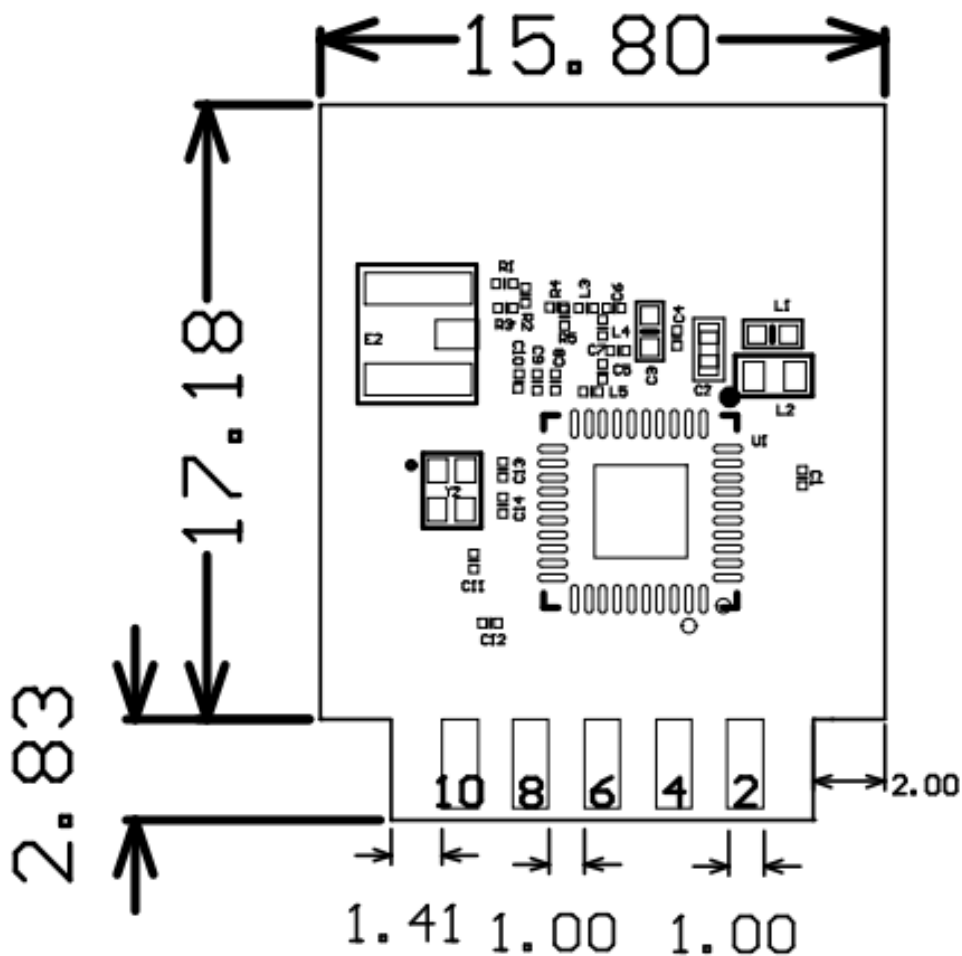

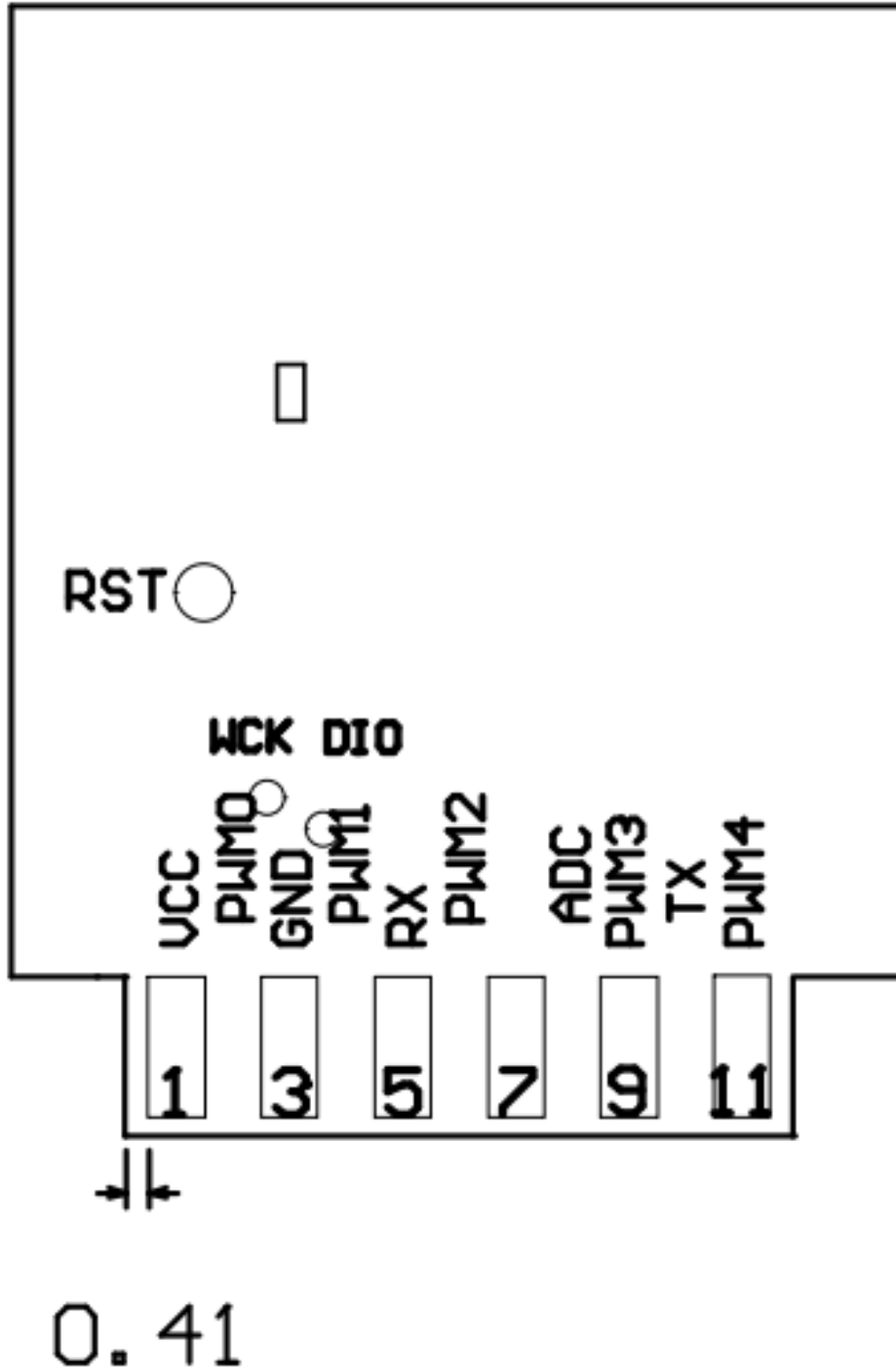

2.2 Pin definition

Pin number	Symbol	I/O type	Function
1	VCC	P	Power supply pin

Pin number	Symbol	I/O type	Functio
2	P2	I/O	Common I/O pin, which corresponds to (Pin 2) of IC
3	GND	P	
4	P9	I/O	Common I/O pin, which corresponds to (Pin 9) of IC
5	P16	I	Common I/O pin, which corresponds to (Pin 16) of IC
6	P20	I/O	Common I/O pin, which corresponds to (Pin 20) of IC
7	P23	I/O	Common I/O pin, which corresponds to (Pin 23) of IC
8	P28	I/O	Common I/O pin, which corresponds to (Pin 28) of IC
9	P21	I/O	Common I/O pin, which corresponds to (Pin 21) of IC
10	P17	I/O	Common I/O pin, which corresponds to (Pin 21) of IC

Pin number	Symbol	I/O type	Function
11	P22	I/O	Common I/O pin, which corresponds to (Pin 22) of IC

Note: P indicates a power supply pin and I/O indicates an input/output pin.

3 Electrical parameters

3.1 Absolute electrical parameters

Parameter	Description	Minimum value	Maximum value	Unit
Ta	Operating temperature	-40	105	°C
VBAT	Power supply voltage	1.8 (2.8V or higher is recommended)	3.6	V
ESD voltage (human body model)	TAMB-25°C	-	2	KV
ESD voltage (machine model)	TAMB-25°C	-	0.2	KV

3.2 Normal working conditions

Parameter	Description	Minimum value	Typical value	Maximum value	Unit
Ta	Operating temperature	-40	-	105	°C
VCC	Operating voltage	1.8 (2.8V or higher is recommended)	3.3	3.6	V
VIL	I/O low-level input	-	-	VDD*0.3	V

Parameter	Description	Minimum value	Typical value	Maximum value	Unit
VIH	I/O high-level input	VDD*0.7	-	-	V
VOL	I/O low-level output	-	-	VDD*0.2	V
VOH	I/O high-level output	VDD*0.8	-	-	V

3.3 TX and RX power consumption

Working status	Mode	Rate	Transmit power/receive	Peak value (Typical value)	Unit
Transmit	-	250Kbps	+0 dBm	15	mA
Transmit	-	250Kbps	+10 dBm	25	mA
Receive	-	250Kbps	Constantly receive	11	mA

3.4 Operating current

Working mode	Working status, Ta = 25°C	Maximum value (Typical value)	Unit
Quick network connection state	The module is in the fast network connection state	20	mA
Network connection state	The module is connected to the network	19	mA
Deep sleep mode	Deep sleep mode, reserve 32-KB SRAM	4.9	uA

4 RF parameters

4.1 Basic RF features

Parameter	Description
Working frequency	2.405 to 2.480 GHz
Zigbee standard	IEEE 802.15.4
Data transmission rate	250 Kbps
Antenna type	PCB antenna with a gain of 1.0 dBi, IPEX optional

4.2 TX performance

TX performance

Parameter	Minimum value	Typical value	Maximum value	Unit
Maximum output power (250 Kbps)	-	10	-	dBm
Minimum output power (250 Kbps)	-	-10	-	dBm
Output power adjustment stepping	-	1	2	dBm
Output spectrum adjacent channel suppression	-	-30	-	dBc
Frequency error	-10	-	10	ppm

4.3 RX performance

RX sensitivity:

Parameter	Minimum value	Typical value	Maximum value	Unit
PER<1% RX sensitivity (250 Kbps)		-100		dBm

5 Requirements on power-on sequence

Figure 2-4 Initial Power-up sequence

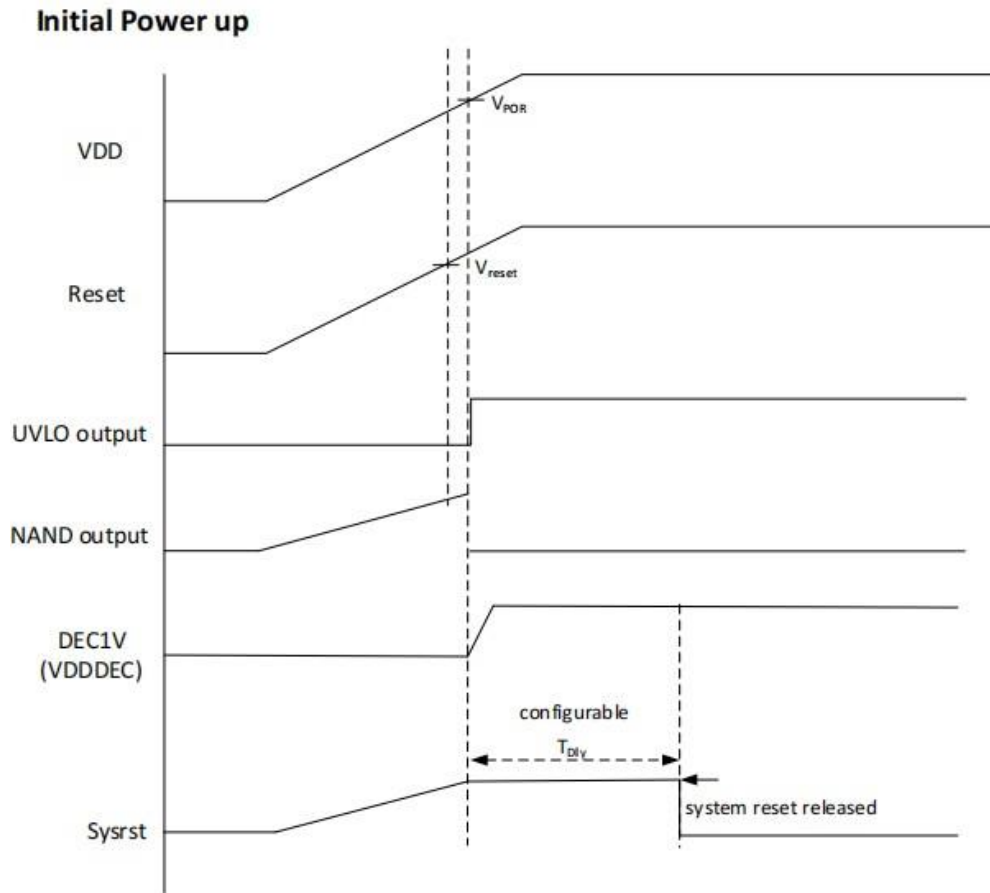

Symbol	Parameter	Min.	Typ.	Max.	Unit
V_{POR}	VDD voltage when V_{UVLO} turns to high level		1.62		V
V_{Pdn}	VDD voltage when V_{UVLO} turns to low level		1.55		V
Supply rise time (from 1.6V to 1.8V)	t_r		10	ms	

The Z2 chip has requirements on the power-on sequence. During the power-on process, the system starts when the RST pin reaches 1.62V. At this time, the VCC needs to reach more than 1.8V within 10ms. Because the RST pin has the RC link, the VCC of the bare module is much more than 1.8V when the RST reaches 1.62V. In some cases that the large capacitance in the power driver connected to the Z2 chip module charges or discharges, if the module voltage is not fully discharged

below 0.6V, the module will probably crash when it is restarted. It is required that the power supply pin VCC_3.3V of the module needs to be connected with a dummy load of 1K to release power quickly. You can refer to the following figure which shows parts of power-driven links.

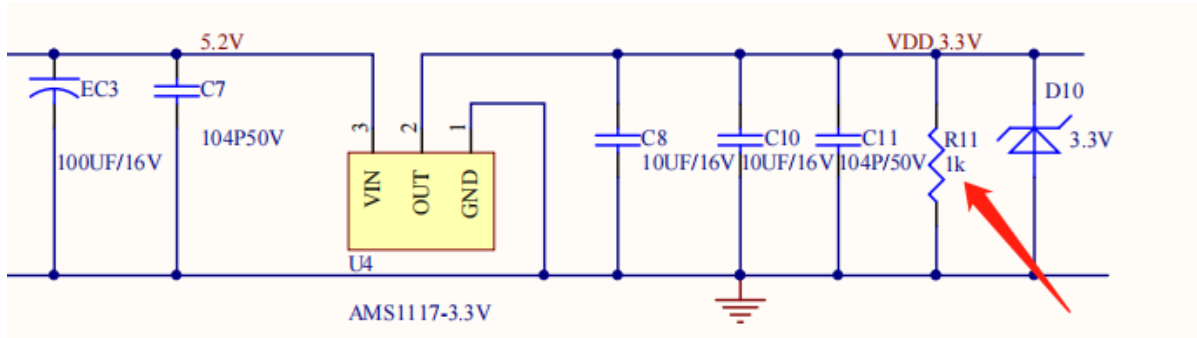

6 Antenna

6.1 Antenna type

ZTU-ZB02 uses only the onboard PCB antenna. The ZTU-ZB02-IPEX module can use the IPEX antenna.

7 Packaging information and production instructions

7.1 Mechanical dimensions

The PCB dimensions are 20.01mm (L) × 15.8mm (W) × 2.8±0.15mm (H).

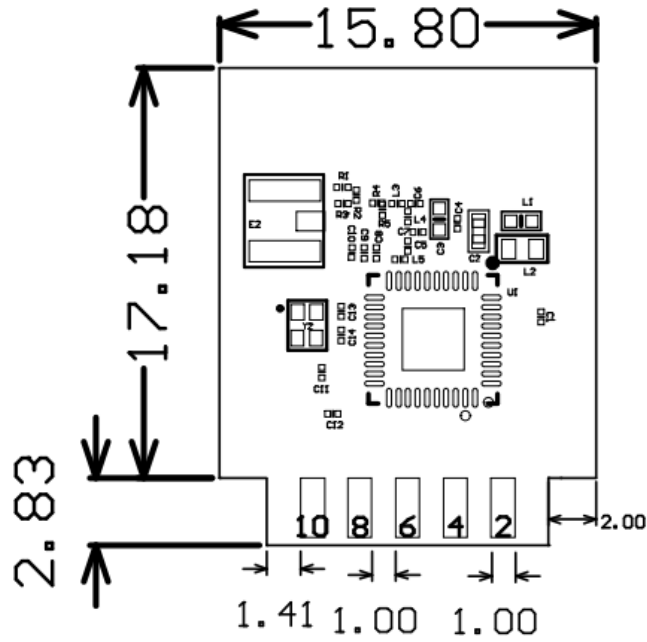

7.2 Side view

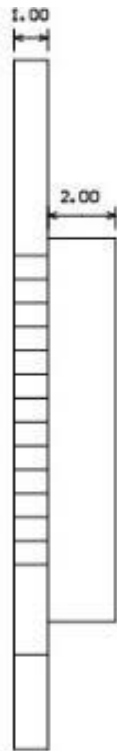

单位: mm
Unit: mm

模组外形公差: $\pm 0.3\text{mm}$
Module form factor tolerance: $\pm 0.3\text{mm}$

板厚公差: $\pm 0.1\text{mm}$
Plate thickness tolerance: $\pm 0.1\text{mm}$

屏蔽盖高度公差: $\pm 0.05\text{mm}$
Shield cover height tolerance: $\pm 0.05\text{mm}$

Side View

7.3 The schematic diagram of footprint

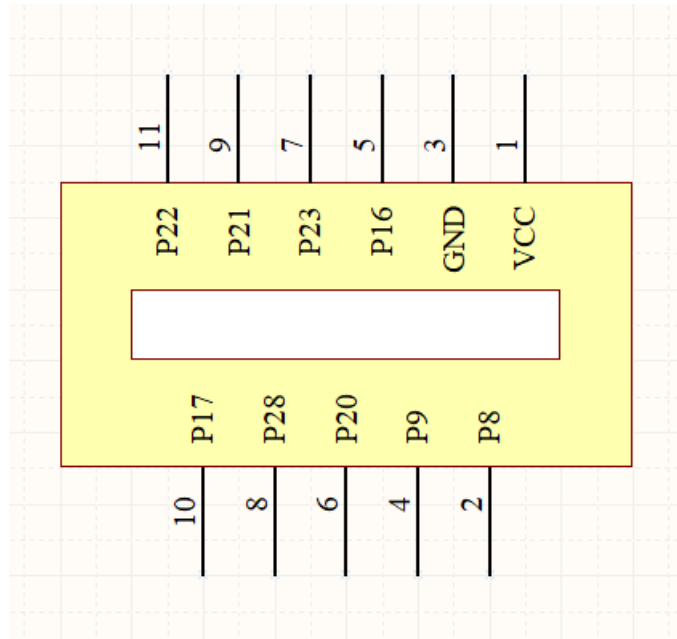

7.4 Diagram of PCB footprint

Diagram of PCB footprint-SMT:

Please contact our sales staff to obtain the package file.

7.5 Production instructions

1. For the modules that can be packaged with the SMT or in an in-line way, you can select either of them according to the PCB design solutions of customers. If a PCB is designed to be SMT-packaged, package the module with the SMT. If a PCB is designed to be in-line-packaged, package the module in an in-line way. After being unpacked, the module must be soldered within 24 hours. Otherwise, it

needs to be put into the drying cupboard where the relative humidity is not greater than 10%; or it needs to be packaged again under vacuum and the exposure time needs to be recorded (the total exposure time cannot exceed 168 hours).

- (SMT process) SMT devices:
 - Mounter
 - SPI
 - Reflow soldering machine
 - Thermal profiler
 - Automated optical inspection (AOI) equipment
- (Wave soldering process) Wave soldering devices
 - Wave soldering equipment
 - Wave soldering fixture
 - Constant-temperature soldering iron
 - Tin bar, tin wire, and flux
 - Thermal profiler
- Baking devices:
 - Cabinet oven
 - Anti-electrostatic and heat-resistant trays
 - Anti-electrostatic and heat-resistant gloves

2. Storage conditions for a delivered module:

- The moisture-proof bag must be placed in an environment where the temperature is below 40°C and the relative humidity is lower than 90%.
- The shelf life of a dry-packaged product is 12 months from the date when the product is packaged and sealed.
- There is a humidity indicator card (HIC) in the packaging bag.

```
1 ! [HIC-SMT and in-line module.png] (https://airtake-public-data-12541
2 53901.cos.ap-shanghai.myqcloud.com/goat/20210410/2_c61fd34d2a6464d8cb
3 ee05f63689786.png)
```

3. The module needs to be baked in the following cases:

- The packaging bag is damaged before unpacking.
- There is no humidity indicator card (HIC) in the packaging bag.
- After unpacking, circles of 10% and above on the HIC become pink.

- The total exposure time has lasted for over 168 hours since unpacking.
- More than 12 months have passed since the sealing of the bag.

4. Baking settings:

- Temperature: 60°C and $\leq 5\%$ RH for reel package and 125°C and $\leq 5\%$ RH for tray package (please use the heat-resistant tray rather than plastic container)
- Time: 48 hours for reel package and 12 hours for tray package
- Alarm temperature: 65°C for reel package and 135°C for tray package
- Production-ready temperature after natural cooling: $< 36^\circ\text{C}$
- Re-baking situation: If a module remains unused for over 168 hours after being baked, it needs to be baked again.
- If a batch of modules is not baked within 168 hours, do not use the reflow soldering or wave soldering to solder them. Because these modules are Level-3 moisture-sensitive devices, they are very likely to get damp when exposed beyond the allowable time. In this case, if they are soldered at high temperatures, it may result in device failure or poor soldering.

5. In the whole production process, take electrostatic discharge (ESD) protective measures.

6. To guarantee the passing rate, it is recommended that you use the SPI and AOI to monitor the quality of solder paste printing and mounting.

7.6 Recommended oven temperature curve

Select a proper soldering manner according to the process. For the SMT process, please refer to the recommended oven temperature curve of reflow soldering. For the wave soldering process, please refer to the recommended oven temperature curve of wave soldering. There are some differences between the set temperatures and the actual temperatures. All the temperatures shown in this module datasheet are obtained through actual measurements.

Manner 1: SMT process (Recommended oven temperature curve of reflow soldering)

Set oven temperatures according to the following curve.

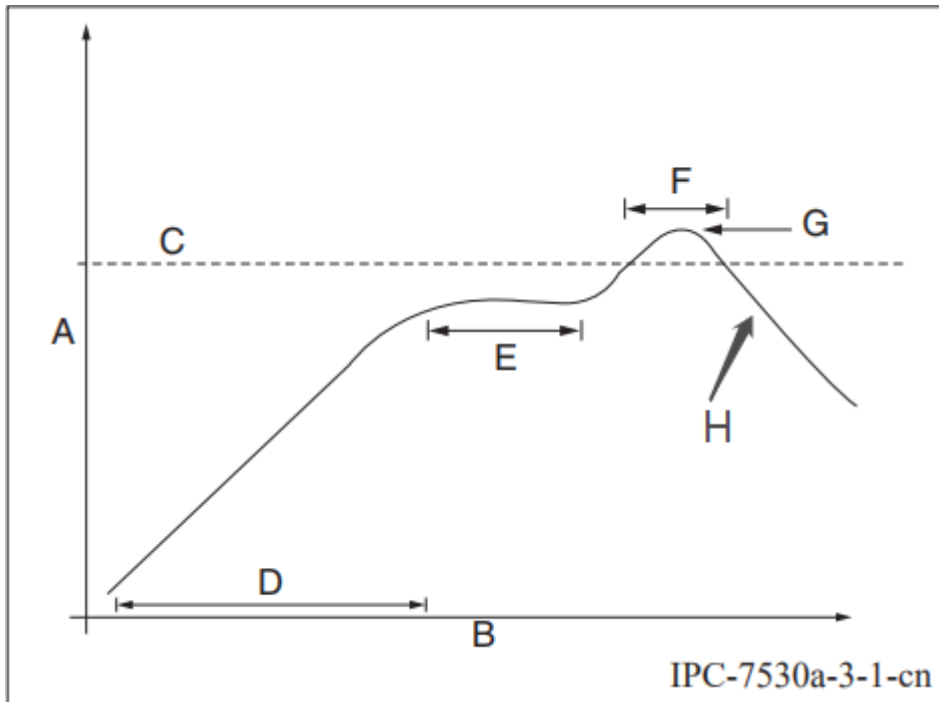

- A: Temperature axis
- B: Time axis
- C: Liquidus temperature: 217 to 220°C
- D: Ramp-up slope: 1 to 3°C/s
- E: Duration of constant temperature: 60 to 120s; the range of constant temperature: 150 to 200°C
- F: Duration above the liquidus: 50 to 70s
- G: Peak temperature: 235 to 245°C
- H: Ramp-down slope: 1 to 4°C/s

Note: The above curve is just an example of the solder paste SAC305. For more details about other solder pastes, please refer to Recommended oven temperature curve in the solder paste specifications.

Manner 2: Wave soldering process (Oven temperature curve of wave soldering)

Set oven temperatures according to the following temperature curve of wave soldering. The peak temperature is 260°C±5°C.

DIP Type Product Pass Wavesolder Graph

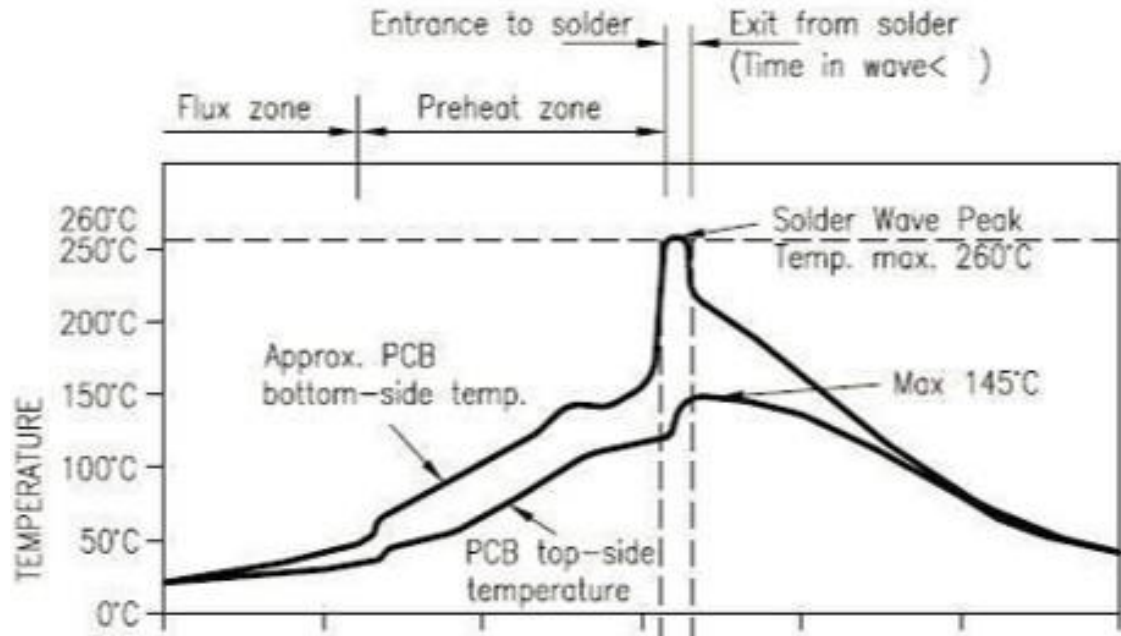

Suggestions on oven temperature curve of wave soldering

Suggestions on manual soldering temperature

Preheat temperature	80 to 130 °C	Soldering temperature	360±20°C
Preheat time	75 to 100s	Soldering time	< 3s/point
Peak contact time	3 to 5s	NA	NA
Temperature of tin cylinder	260±5°C	NA	NA
Ramp-up slope	≤2°C/s	NA	NA
Ramp-down slope	≤6°C/s	NA	NA

8 MOQ and packaging information

Product model	MOQ (pcs)	Shipping packaging method	The number of modules per reel	The number of reels per carton
ZTU-ZB02	4400	Tape reel	1100	4

9 Appendix: Statement

FCC Caution: Any changes or modifications not expressly approved by the party responsible for compliance could void the user's authority to operate this device.

This device complies with Part 15 of the FCC Rules. Operation is subject to the following two conditions: (1) This device may not cause harmful interference, and (2) this device must accept any interference received, including interference that may cause undesired operation.

Note: This device has been tested and found to comply with the limits for a Class B digital device, according to part 15 of the FCC Rules. These limits are designed to provide reasonable protection against harmful interference in a residential installation. This device generates, uses, and can radiate radio frequency energy and, if not installed and used following the instructions, may cause harmful interference to radio communications. However, there is no guarantee that interference will not occur in a particular installation.

If this device does cause harmful interference to radio or television reception, which can be determined by turning the device off and on, the user is encouraged to try to correct the interference by one or more of the following measures:

- Reorient or relocate the receiving antenna.
- Increase the separation between the device and receiver.
- Connect the device into an outlet on a circuit different from that to which the receiver is connected.
- Consult the dealer or an experienced radio/TV technician for help.

Radiation Exposure Statement

This device complies with FCC radiation exposure limits set forth for an uncontrolled rolled environment. This device should be installed and operated with a minimum distance of 20cm between the radiator and your body.

Important Note

This radio module must not be installed to co-locate and operating simultaneously with other radios in the host system except following FCC multi-transmitter product procedures. Additional testing and device authorization may be required to operate simultaneously with other radios.

The availability of some specific channels and/or operational frequency bands are country-dependent and are firmware programmed at the factory to match the intended destination. The firmware setting is not accessible by the end-user.

The host product manufacturer is responsible for compliance with any other FCC rules that apply to the host not covered by the modular transmitter grant of certification. The final host product still requires Part 15 Subpart B compliance testing with the modular transmitter installed.

The end-user manual shall include all required regulatory information/warnings as shown in this manual, including “This product must be installed and operated with a minimum distance of 20 cm between the radiator and user body” .

This device has got an FCC ID: 2AHRE-ZTU-ZB02. The end product must be labelled in a visible area with the following: “Contains Transmitter Module FCC ID: 2AHRE-ZTU-ZB02”

.

This device is intended only for OEM integrators under the following conditions:

The antenna must be installed such that 20cm is maintained between the antenna and users, and the transmitter module may not be co-located with any other transmitter or antenna.

Requirement per KDB996369 D03

2.2 List of applicable FCC rules

List the FCC rules that are applicable to the modular transmitter. These are the rules that specifically establish the bands of operation, the power, spurious emissions, and operating fundamental frequencies. DO NOT list compliance to unintentional-radiator rules (Part 15 Subpart B) since that is not a condition of a module grant that is extended to a host manufacturer. See also Section 2.10 below concerning the need to notify host manufacturers that further testing is required.³

Explanation: This module meets the requirements of FCC part 15C(15.247).it specifically establish the 6dB Bandwidth,, Peak Output Power, Radiated Spurious Emission, Power Spectral Density, Restricted Band of Operation and Band Edge (Out of Band Emissions) Measurement

2.3 Summarize the specific operational use conditions

Describe use conditions that are applicable to the modular transmitter, including for example any limits on antennas, etc. For example, if point-to-point antennas are used that require reduction in power or compensation for cable loss, then this information must be in the instructions. If the use condition limitations extend to professional users, then instructions must state that this information also extends to the host manufacturer's instruction manual. In addition, certain information may also be needed, such as peak gain per frequency band and minimum gain.

Explanation: The EUT only have one PCB antenna, Yes, the module contains a permanently attached antenna, The antenna gain is 1dBi. The use condition of the prototype is mobile.

2.4 Limited module procedures

If a modular transmitter is approved as a "limited module," then the module manufacturer is responsible for approving the host environment that the limited module is used with. The manufacturer of a limited module must describe, both in the filing and in the installation instructions, the alternative means that the limited module manufacturer uses to verify that the host meets the necessary requirements to satisfy the module limiting conditions.

A limited module manufacturer has the flexibility to define its alternative method to address the conditions that limit the initial approval, such as: shielding, minimum signaling amplitude, buffered modulation/data inputs, or power supply regulation. The alternative method could include that the limited module manufacturer reviews detailed test data or host designs prior to giving the host manufacturer approval.

This limited module procedure is also applicable for RF exposure evaluation when it is necessary to demonstrate compliance in a specific host. The module manufacturer must state how control of the product into which the modular transmitter will be installed will be maintained such that full compliance of the product is always ensured. For additional hosts other than the specific host originally granted with a limited

module, a Class II permissive change is required on the module grant to register the additional host as a specific host also approved with the module.

Explanation: The module is a single module.

2.5 Trace antenna designs

For a modular transmitter with trace antenna designs, see the guidance in Question 11 of KDB Publication 996369 D02 FAQ – Modules for Micro-Strip Antennas and traces. The integration information shall include for the TCB review the integration instructions for the following aspects: layout of trace design, parts list (BOM), antenna, connectors, and isolation requirements.

- a) Information that includes permitted variances (e.g., trace boundary limits, thickness, length, width, shape(s), dielectric constant, and impedance as applicable for each type of antenna);
- b) Each design shall be considered a different type (e.g., antenna length in multiple(s) of frequency, the wavelength, and antenna shape (traces in phase) can affect antenna gain and must be considered);
- c) The parameters shall be provided in a manner permitting host manufacturers to design the printed circuit (PC) board layout;
- d) Appropriate parts by manufacturer and specifications;
- e) Test procedures for design verification; and
- f) Production test procedures for ensuring compliance.

The module grantee shall provide a notice that any deviation(s) from the defined parameters of the antenna trace, as described by the instructions, require that the host product manufacturer must notify the module grantee that they wish to change the antenna trace design. In this case, a Class II permissive change application is required to be filed by the grantee, or the host manufacturer can take responsibility through the change in FCC ID (new application) procedure followed by a Class II permissive change application.

Explanation: No, The module has no tracking antenna design, is PCB antenna.

2.6 RF exposure considerations

It is essential for module grantees to clearly and explicitly state the RF exposure conditions that permit a host product manufacturer to use the module. Two types of instructions are required for RF exposure information: (1) to the host product manufacturer, to define the application conditions (mobile, portable – xx cm from a person's body); and (2) additional text needed for the host product manufacturer to provide to end users in their end-product manuals. If RF exposure statements and use conditions are not provided, then the host product manufacturer is required to take responsibility of the module through a change in FCC ID (new application).

Explanation: This module complies with FCC RF radiation exposure limits set forth for an uncontrolled environment, This equipment should be installed and operated with a minimum distance of 20 centimeters between the radiator and your body." This module is designed to comply with the FCC statement,
FCC ID: 2AHRE-ZTU-ZB02

2.7 Antennas

A list of antennas included in the application for certification must be provided in the instructions. For modular transmitters approved as limited modules, all applicable professional installer instructions must be included as part of the information to the host product manufacturer. The antenna list shall also identify the antenna types (monopole, PIFA, dipole, etc. (note that for example an “omni-directional antenna” is not considered to be a specific “antenna type”)).

For situations where the host product manufacturer is responsible for an external connector, for example with an RF pin and antenna trace design, the integration instructions shall inform the installer that unique antenna connector must be used on the Part 15 authorized transmitters used in the host product. The module manufacturers shall provide a list of acceptable unique connectors.

Explanation: The EUT only have one PCB antenna, Yes, the module contains a permanently attached antenna, The antenna gain is 1dBi.

2.8 Label and compliance information

Grantees are responsible for the continued compliance of their modules to the FCC rules. This includes advising host product manufacturers that they need to provide a physical or e-label stating “Contains FCC ID” with their finished product. See Guidelines for Labeling and User Information for RF Devices – KDB Publication 784748.

Explanation: The host system using this module, should have label in a visible area indicated the following texts: "Contains FCC ID: 2AHRE-ZTU-ZB02

2.9 Information on test modes and additional testing requirements

Additional guidance for testing host products is given in KDB Publication 996369 D04 Module Integration Guide. Test modes should take into consideration different operational conditions for a stand-alone modular transmitter in a host, as well as for multiple simultaneously transmitting modules or other transmitters in a host product.

The grantee should provide information on how to configure test modes for host product evaluation for different operational conditions for a stand-alone modular transmitter in a host, versus with multiple, simultaneously transmitting modules or other transmitters in a host.

Grantees can increase the utility of their modular transmitters by providing special means, modes, or instructions that simulates or characterizes a connection by enabling a transmitter. This can greatly simplify a host manufacturer’s determination that a module as installed in a host complies with FCC requirements.

Explanation: WiFiRanger, A LinOra Company can increase the utility of our modular transmitters by providing instructions that simulates or characterizes a connection by enabling a transmitter.

2.10 Additional testing, Part 15 Subpart B disclaimer

The grantee should include a statement that the modular transmitter is only FCC authorized for the specific rule parts (i.e., FCC transmitter rules) listed on the grant, and that the host product manufacturer is responsible for compliance to any other FCC rules that apply to the host not covered by the modular transmitter grant of certification. If the grantee markets their product as being Part 15

Subpart B compliant (when it also contains unintentional-radiator digital circuitry), then the grantee shall provide a notice stating that the final host product still requires Part 15 Subpart B compliance testing with the modular transmitter installed.

Explanation: The module without unintentional-radiator digital circuitry, so the module does not require an evaluation by FCC Part 15 Subpart B. The host should be evaluated by the FCC Subpart B.

This product uses PCB antenna with a maximum antenna gain of 1dBi

As long as the 2 conditions above are met, further transmitter tests will not be required. However, the OEM integrator is still responsible for testing their end-product for any additional compliance requirements required with this module installed.

Declaration of Conformity European Notice



Hereby, Hangzhou Tuya Information Technology Co., Ltd declares that this module product is in compliance with essential requirements and other relevant provisions of Directive 2014/53/EU, 2011/65/EU. A copy of the Declaration of conformity can be found at



This product must not be disposed of as normal household waste, in accordance with the EU directive for waste electrical and electronic equipment (WEEE-2012/19/EU). Instead, it should be disposed of by returning it to the point of sale, or to a municipal recycling collection point.

The device could be used with a separation distance of 20cm to the human body.

i