



# FCC Part 15C Test Report

## FCC ID: 2AIGA38021

Product Name:	WIFI Router
Trademark:	N/A
Model Name :	38021
Prepared For :	HearTV,LLC
Address :	2701 Via Orange Way, Suite 1.Spring Valley, CA 91978, USA
Prepared By :	Shenzhen BCTC Technology Co., Ltd.
Address :	No.101,Yousong Road,Longhua New District, Shenzhen,China
Test Date:	May 11– May 18, 2016
Date of Report :	May 19, 2016
Report No.:	BCTC-160505327E



### TEST RESULT CERTIFICATION

**Applicant's name** ..... : HearTV,LLC  
**Address** ..... : 2701 Via Orange Way, Suite 1.Spring Valley, CA 91978,  
USA

**Manufacture's Name**..... : SHENZHEN ZHIBOTONG ELECTRONICS CO.,LTD.  
**Address** ..... : 2F,Bldg A,Kangmai Science&Technology Industrial  
Park,Renmin Rd, Guanlan,Longhua District, Shenzhen,  
China

**Product description**

**Product name** ..... : WIFI Router  
**Model and/or type reference** : 38021

**Standards** ..... : FCC Part15.247

**Test procedure**..... ANSI C63.10:2013

This device described above has been tested by BCTC, and the test results show that the equipment under test (EUT) is in compliance with the FCC requirements. And it is applicable only to the tested sample identified in the report.

This report shall not be reproduced except in full, without the written approval of BCTC, this document may be altered or revised by BCTC, personal only, and shall be noted in the revision of the document.

Testing Engineer : Eric Yang  
Eric Yang

Reviewer (Supervisor) : Jade Yang  
Jade Yang

Approved & Authorized Signer(Manager) : Carson Zhang  
Carson Zhang



**Table of Contents**

	<b>Page</b>
<b>1 . SUMMARY OF TEST RESULTS</b>	<b>5</b>
1.1 TEST FACILITY	6
1.2 MEASUREMENT UNCERTAINTY	6
<b>2 . GENERAL INFORMATION</b>	<b>7</b>
2.1 GENERAL DESCRIPTION OF EUT	7
2.2 DESCRIPTION OF TEST MODES	8
2.3 BLOCK DIGRAM SHOWING THE CONFIGURATION OF SYSTEM TESTED	9
2.4 DESCRIPTION OF SUPPORT UNITS(CONDUCTED MODE)	9
2.5 EQUIPMENTS LIST FOR ALL TEST ITEMS	10
<b>3 . EMC EMISSION TEST</b>	<b>11</b>
3.1 CONDUCTED EMISSION MEASUREMENT	11
3.1.1 POWER LINE CONDUCTED EMISSION LIMITS	11
3.1.2 TEST PROCEDURE	11
3.1.3 DEVIATION FROM TEST STANDARD	11
3.1.4 TEST SETUP	12
3.1.5 EUT OPERATING CONDITIONS	12
3.1.6 TEST RESULTS	13
3.2 RADIATED EMISSION MEASUREMENT	15
3.2.1 RADIATED EMISSION LIMITS	15
3.2.2 TEST PROCEDURE	16
3.2.3 DEVIATION FROM TEST STANDARD	16
3.2.4 TEST SETUP	16
3.2.5 EUT OPERATING CONDITIONS	17
3.2.6 TEST RESULTS (BETWEEN 9KHZ – 30 MHZ)	18
3.2.7 TEST RESULTS (BETWEEN 30MHZ – 1GHZ)	19
3.2.8 TEST RESULTS (1GHZ~25GHZ)	21
3.3 RADIATED BAND EMISSION MEASUREMENT	33
3.3.1 TEST REQUIREMENT:	33
3.3.2 TEST PROCEDURE	33
3.3.3 DEVIATION FROM TEST STANDARD	34
3.3.4 TEST SETUP	34
3.3.5 EUT OPERATING CONDITIONS	34
<b>4 . POWER SPECTRAL DENSITY TEST</b>	<b>39</b>



<b>Table of Contents</b>		<b>Page</b>
<b>4.1 APPLIED PROCEDURES / LIMIT</b>		<b>39</b>
4.1.1 TEST PROCEDURE		39
4.1.2 DEVIATION FROM STANDARD		39
4.1.3 TEST SETUP		39
4.1.4 EUT OPERATION CONDITIONS		39
4.1.5 TEST RESULTS		40
<b>5 . BANDWIDTH TEST</b>		<b>56</b>
5.1 APPLIED PROCEDURES / LIMIT		56
5.1.1 TEST PROCEDURE		56
5.1.2 DEVIATION FROM STANDARD		56
5.1.3 TEST SETUP		56
5.1.4 EUT OPERATION CONDITIONS		56
5.1.5 TEST RESULTS		57
<b>6 . PEAK OUTPUT POWER TEST</b>		<b>73</b>
6.1 APPLIED PROCEDURES / LIMIT		73
6.1.1 TEST PROCEDURE		73
6.1.2 DEVIATION FROM STANDARD		73
6.1.3 TEST SETUP		73
6.1.4 EUT OPERATION CONDITIONS		73
6.1.5 TEST RESULTS		74
<b>7 . 100 KHZ BANDWIDTH OF FREQUENCY BAND EDGE</b>		<b>75</b>
7.1 APPLICABLE STANDARD		75
7.2 TEST PROCEDURE		75
7.3 DEVIATION FROM STANDARD		75
7.4 TEST SETUP		75
7.5 EUT OPERATION CONDITIONS		76
7.1 TEST RESULTS		76
<b>8 . ANTENNA REQUIREMENT</b>		<b>85</b>
8.1 STANDARD REQUIREMENT		85
8.2 EUT ANTENNA		85
<b>9 . EUT TEST PHOTO</b>		<b>86</b>
<b>10 . EUT PHOTO</b>		<b>88</b>
<b>APPENDIX-PHOTOGRAPHS OF EUT CONSTRUCTIONAL DETAILS</b>		



## 1. SUMMARY OF TEST RESULTS

Test procedures according to the technical standards:

<b>FCC Part15 (15.247) , Subpart C</b>			
Standard Section	Test Item	Judgment	Remark
15.207	Conducted Emission	PASS	
15.247 (a)(2)	6dB Bandwidth	PASS	
15.247 (b)	Peak Output Power	PASS	
15.247 (c)	Radiated Spurious Emission	PASS	
15.247 (d)	Power Spectral Density	PASS	
15.205	Band Edge Emission	PASS	
15.203	Antenna Requirement	PASS	

NOTE:

(1) "N/A" denotes test is not applicable in this Test Report



## 1.1 TEST FACILITY

Shenzhen BCTC Technology Co., Ltd.

Add. : No.101,Yousong Road,Longhua New District, Shenzhen,China

FCC Registered No.: 187086

## 1.2 MEASUREMENT UNCERTAINTY

The reported uncertainty of measurement  $y \pm U$ , where expanded uncertainty  $U$  is based on a standard uncertainty multiplied by a coverage factor of  $k=2$ , providing a level of confidence of approximately **95 %**.

No.	Item	Uncertainty
1	Conducted Emission Test	$\pm 1.38\text{dB}$
2	RF power,conducted	$\pm 0.16\text{dB}$
3	Spurious emissions,conducted	$\pm 0.21\text{dB}$
4	All emissions,radiated(<1G)	$\pm 4.68\text{dB}$
5	All emissions,radiated(>1G)	$\pm 4.89\text{dB}$
6	Temperature	$\pm 0.5^{\circ}\text{C}$
7	Humidity	$\pm 2\%$



## 2. GENERAL INFORMATION

### 2.1 GENERAL DESCRIPTION OF EUT

Equipment	WIFI Router	
Trade Name	N/A	
Model Name	38021	
Model Difference	N/A	
Product Description	The EUT is a WIFI Router	
	Operation Frequency:	802.11b/g/n20MHz:2412~2462 MHz 802.11n40MHz:2422~2452 MHz
	Modulation Type:	WIFI: OFDM/DSSS
	Bit Rate of Transmitter	802.11b:11/5.5/2/1 Mbps 802.11g:54/48/36/24/18/12/9/6Mbps 802.11n Up to 300Mbps
	Number Of Channel	802.11b/g/n20MHz:11 CH 802.11n40MHz: 7 CH
	Antenna Designation:	Please see Note 3.
	Based on the application, features, or specification exhibited in User's Manual, the EUT is considered as an ITE/Computing Device. More details of EUT technical specification, please refer to the User's Manual.	
Channel List	Please refer to the Note 2.	
Adapter	Model:012D12 I/P:100~240V 47-63Hz 0.4A max O/P:DC 12V 1A	
Power	DC 12V from adapter	
hardware version	--	
Software version	--	
Serial number	--	
Connecting I/O Port(s)	Please refer to the User's Manual	

Note:

1. For a more detailed features description, please refer to the manufacturer's specifications or the User's Manual.



2.

Channel List for 802.11b/g/n(20)							
Channel	Frequency (MHz)	Channel	Frequency (MHz)	Channel	Frequency (MHz)	Channel	Frequency (MHz)
01	2412	04	2427	07	2442	10	2457
02	2417	05	2432	08	2447	11	2462
03	2422	06	2437	09	2452		

Channel List for 802.11n(40)							
Channel	Frequency (MHz)	Channel	Frequency (MHz)	Channel	Frequency (MHz)	Channel	Frequency (MHz)
03	2422	05	2432	07	2442	09	2452
04	2427	06	2437	08	2447		

3.

Table for Filed Antenna

Ant.	Brand	Model Name	Antenna Type	Connector	Gain (dBi)	NOTE
1	N/A	N/A	Internal Antenna		5.0	
2	N/A	N/A	Internal Antenna		5.0	

Note: The EUT incorporates a mimo funtion. Physically, the EUT provide two completed transmitter and two receivers.

## 2.2 DESCRIPTION OF TEST MODES

Pretest Mode	Description
Mode 1	802.11b CH1/ CH6/ CH11
Mode 2	802.11g CH1/ CH6/ CH11
Mode 3	802.11n20 CH1/ CH6/ CH11
Mode 4	802.11n40 CH3/ CH6/ CH9
Mode 5	Link Mode

Conducted Emission	
Final Test Mode	Description
Mode 5	Link Mode

For Radiated Emission	
Final Test Mode	Description
Mode 1	802.11b CH1/ CH6/ CH11
Mode 2	802.11g CH1/ CH6/ CH11
Mode 3	802.11n20 CH1/ CH6/ CH11
Mode 4	802.11n40 CH3/ CH6/ CH9

Note:

(1) The measurements are performed at all Bit Rate of Transmitter, the worst data was reported.



### 2.3 BLOCK DIGRAM SHOWING THE CONFIGURATION OF SYSTEM TESTED

Conducted Emission Test



Radiated Spurious Emission Test



### 2.4 DESCRIPTION OF SUPPORT UNITS(CONDUCTED MODE)

The EUT has been tested as an independent unit together with other necessary accessories or support units. The following support units or accessories were used to form a representative test configuration during the tests.

Item	Equipment	Mfr/Brand	Model/Type No.	Series No.	Note
E-1	WIFI Router	N/A	38021	N/A	EUT
E-3	Adapter	N/A	012D12	N/A	

Item	Shielded Type	Ferrite Core	Length	Note
C1	NO	NO	0.8M	Unshielded

Note:

- (1) The support equipment was authorized by Declaration of Confirmation.
- (2) For detachable type I/O cable should be specified the length in cm in 『Length』 column.



## 2.5 EQUIPMENTS LIST FOR ALL TEST ITEMS

### Radiation Test equipment

Item	Kind of Equipment	Manufacturer	Type No.	Serial No.	Last calibration	Calibrated until
1	Spectrum Analyzer	Agilent	E4407B	MY4510957 2	2015.08.25	2016.08.24
2	Test Receiver	R&S	ESPI	101396	2015.08.25	2016.08.24
3	Bilog Antenna	SCHWARZB ECK	VULB9160	VULB9160- 3369	2015.08.25	2016.08.24
4	50Ω Coaxial Switch	Anritsu	MP59B	620026441 6	2015.07.06	2016.07.05
5	Spectrum Analyzer	Agilent	N9020A	MY5051041	2015.07.06	2016.07.05
6	Horn Antenna	SCHWARZB ECK	9120D	9120D-1275	2015.08.25	2016.08.24
7	Horn Ant	Schwarzbeck	BBHA 9170	9170-181	2015.07.06	2016.07.05
8	Amplifier	SCHWARZB ECK	BBV9718	9718-270	2015.08.25	2016.08.24
9	Amplifier	SCHWARZB ECK	BBV9743	9743-119	2015.08.25	2016.08.24
10	Loop Antenna	ARA	PL3802130/ B	1029	2015.07.06	2016.07.05
11	Power Meter	R&S	NRVS	100696	2015.07.06	2016.07.05
12	Power Sensor	R&S	URV5-Z4	0395.1619. 05	2015.07.06	2016.07.05
13	RF cables	R&S	N/A	N/A	2015.07.06	2016.07.05

### Conduction Test equipment

Item	Kind of Equipment	Manufacturer	Type No.	Serial No.	Last calibration	Calibrated until
1	Test Receiver	R&S	ESCI	1166.5950K 03-101165- ha	2015.06.06	2016.06.05
2	LISN	R&S	NSLK81 26	812646 6	2015.08.24	2016.08.23
3	LISN	R&S	NSLK81 26	812648 7	2015.08.24	2016.08.23
4	50Ω Coaxial Switch	Anritsu	MP59B	620026441 7	2015.06.07	2016.06.06
5	RF cables	R&S	R204	R20X	2015.07.06	2016.07.05



### 3. EMC EMISSION TEST

#### 3.1 CONDUCTED EMISSION MEASUREMENT

##### 3.1.1 POWER LINE CONDUCTED EMISSION Limits (Frequency Range 150KHz-30MHz)

FREQUENCY (MHz)	Class A (dBuV)		Class B (dBuV)		Standard
	Quasi-peak	Average	Quasi-peak	Average	
0.15 -0.5	79.00	66.00	66 - 56 *	56 - 46 *	FCC
0.50 -5.0	73.00	60.00	56.00	46.00	FCC
5.0 -30.0	73.00	60.00	60.00	50.00	FCC

Note:

- (1) The tighter limit applies at the band edges.
- (2) The limit of " \* " marked band means the limitation decreases linearly with the logarithm of the frequency in the range.

The following table is the setting of the receiver

Receiver Parameters	Setting
Attenuation	10 dB
Start Frequency	0.15 MHz
Stop Frequency	30 MHz
IF Bandwidth	9 kHz

##### 3.1.2 TEST PROCEDURE

- a. The EUT was placed 0.8 meters from the horizontal ground plane with EUT being connected to the power mains through a line impedance stabilization network (LISN). All other support equipments powered from additional LISN(s). The LISN provide 50 Ohm/ 50uH of coupling impedance for the measuring instrument.
- b. Interconnecting cables that hang closer than 40 cm to the ground plane shall be folded back and forth in the center forming a bundle 30 to 40 cm long.
- c. I/O cables that are not connected to a peripheral shall be bundled in the center. The end of the cable may be terminated, if required, using the correct terminating impedance. The overall length shall not exceed 1 m.
- d. LISN at least 80 cm from nearest part of EUT chassis.
- e. For the actual test configuration, please refer to the related Item –EUT Test Photos.

##### 3.1.3 DEVIATION FROM TEST STANDARD

No deviation

### 3.1.4 TEST SETUP

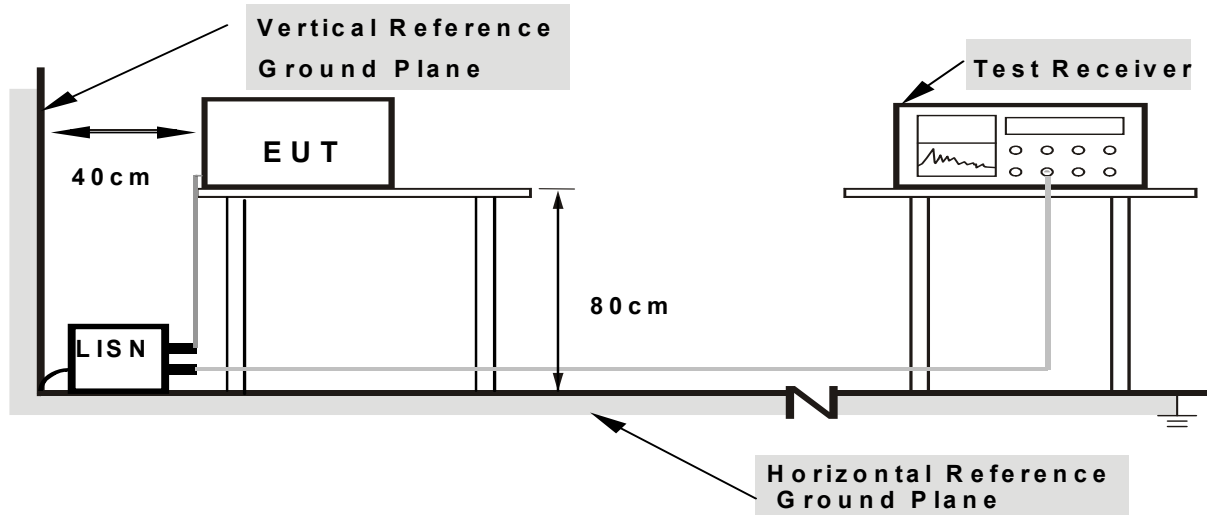

**Note: 1. Support units were connected to second LISN.**

**2. Both of LISNs (AMN) are 80 cm from EUT and at least 80 cm from other units and other metal planes**

### 3.1.5 EUT OPERATING CONDITIONS

The EUT was configured for testing in a typical fashion (as a customer would normally use it). The EUT has been programmed to continuously transmit during test. This operating condition was tested and used to collect the included data.

We pretest AC 120V and AC 240V, the worst voltage was AC 120V and the data recording in the report.



**3.1.6 TEST RESULTS**

Temperature :	26°C	Relative Humidity :	54%
Pressure :	1010hPa	Phase :	L
Test Voltage :	DC 12V from adapter	Test Mode :	Mode 5

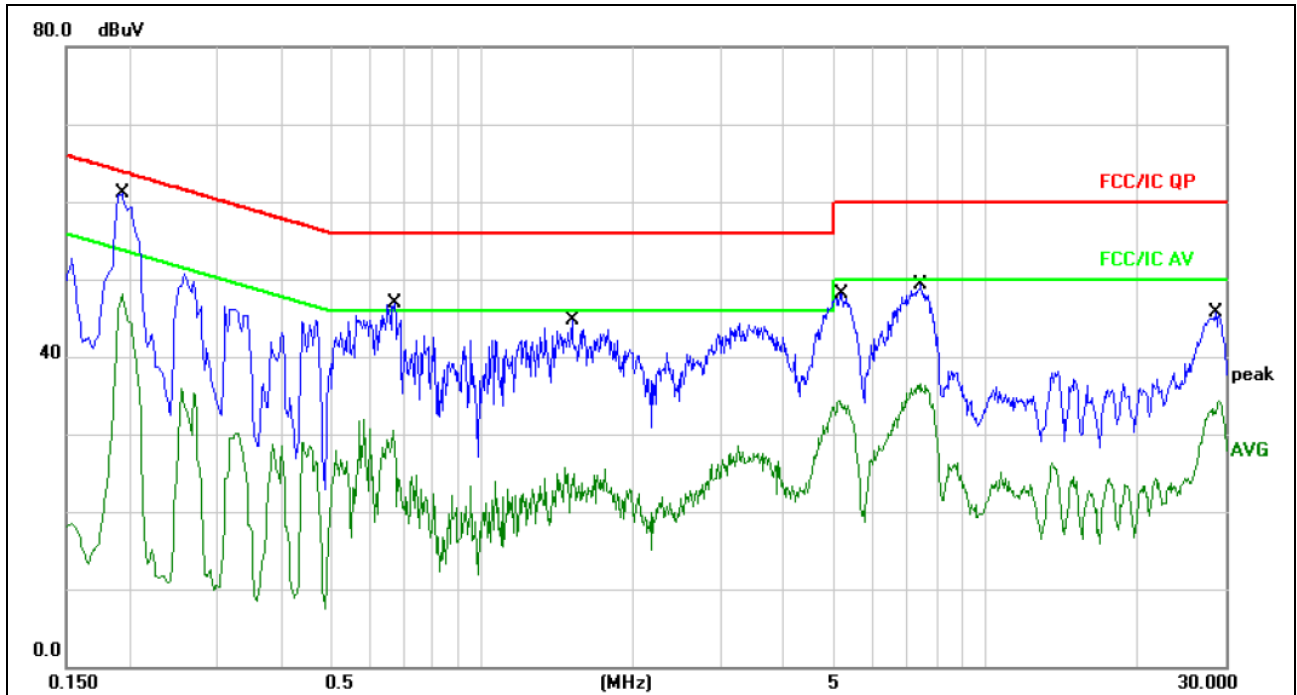

**Remark:**

1. All readings are Quasi-Peak and Average values.
2. Factor = Insertion Loss + Cable Loss.

No. Mk.	Freq. MHz	Reading Level dBuV	Correct Factor dB	Measure- ment dBuV	Limit dBuV	Over dB	Detector	Comment
1 *	0.1940	50.94	10.06	61.00	63.86	-2.86	QP	
2	0.1940	38.12	10.06	48.18	53.86	-5.68	AVG	
3	0.6700	36.80	10.13	46.93	56.00	-9.07	QP	
4	0.6700	20.30	10.13	30.43	46.00	-15.57	AVG	
5	1.5140	34.56	10.17	44.73	56.00	-11.27	QP	
6	1.5140	14.69	10.17	24.86	46.00	-21.14	AVG	
7	5.1140	37.88	10.14	48.02	60.00	-11.98	QP	
8	5.1140	24.24	10.14	34.38	50.00	-15.62	AVG	
9	7.4860	39.12	10.10	49.22	60.00	-10.78	QP	
10	7.4860	26.48	10.10	36.58	50.00	-13.42	AVG	
11	28.7380	35.44	10.22	45.66	60.00	-14.34	QP	
12	28.7380	24.06	10.22	34.28	50.00	-15.72	AVG	



Temperature :	26°C	Relative Humidity :	54%
Pressure :	1010hPa	Phase :	N
Test Voltage :	DC 12V from adapter	Test Mode :	Mode 5

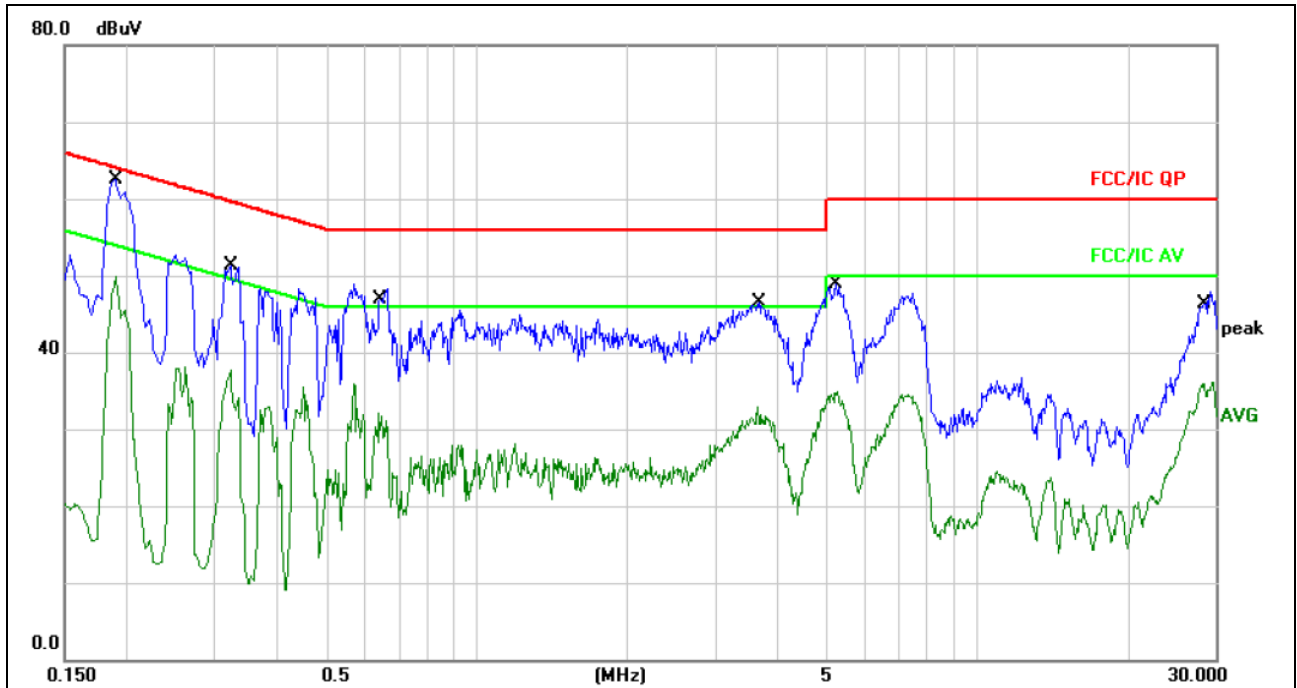

Remark:

1. All readings are Quasi-Peak and Average values.
2. Factor = Insertion Loss + Cable Loss.

No. Mk.	Freq. MHz	Reading Level dBuV	Correct Factor dB	Measure- ment dBuV	Limit dB	Over dB	Detector	Comment
1 *	0.1900	52.48	10.06	62.54	64.03	-1.49	QP	
2	0.1900	39.92	10.06	49.98	54.03	-4.05	AVG	
3	0.3220	41.17	10.10	51.27	59.65	-8.38	QP	
4	0.3220	27.66	10.10	37.76	49.65	-11.89	AVG	
5	0.6460	38.20	10.13	48.33	56.00	-7.67	QP	
6	0.6460	21.57	10.13	31.70	46.00	-14.30	AVG	
7	3.6540	36.42	10.17	46.59	56.00	-9.41	QP	
8	3.6540	22.69	10.17	32.86	46.00	-13.14	AVG	
9	5.2340	38.73	10.14	48.87	60.00	-11.13	QP	
10	5.2340	24.86	10.14	35.00	50.00	-15.00	AVG	
11	28.5380	37.68	10.22	47.90	60.00	-12.10	QP	
12	28.5380	25.73	10.22	35.95	50.00	-14.05	AVG	



### 3.2 RADIATED EMISSION MEASUREMENT

#### 3.2.1 RADIATED EMISSION LIMITS (Frequency Range 9kHz-1000MHz)

20dBc in any 100 kHz bandwidth outside the operating frequency band. In case the emission fall within the restricted band specified on 15.205(a), then the 15.209(a) limit in the table below has to be followed.

Frequencies (MHz)	Field Strength (microrvolts/meter)	Measurement Distance (meters)
0.009~0.490	2400/F(KHz)	300
0.490~1.705	24000/F(KHz)	30
1.705~30.0	30	30
30~88	100	3
88~216	150	3
216~960	200	3
Above 960	500	3

#### LIMITS OF RADIATED EMISSION MEASUREMENT (Above 1000MHz)

FREQUENCY (MHz)	Class B (dBuV/m) (at 3M)	
	PEAK	AVERAGE
Above 1000	74	54

Notes:

- (1) The limit for radiated test was performed according to FCC PART 15C.
- (2) The tighter limit applies at the band edges.
- (3) Emission level (dBuV/m)=20log Emission level (uV/m).

Spectrum Parameter	Setting
Attenuation	Auto
Start Frequency	1000 MHz
Stop Frequency	25GHz
RB / VB (emission in restricted band)	1 MHz / 1 MHz for Peak, 1 MHz / 10Hz for Average

Receiver Parameter	Setting
Attenuation	Auto
Start ~ Stop Frequency	9kHz~150kHz / RB 200Hz for QP
Start ~ Stop Frequency	150kHz~30MHz / RB 9kHz for QP
Start ~ Stop Frequency	30MHz~1000MHz / RB 120kHz for QP

### 3.2.2 TEST PROCEDURE

Below 1GHz test procedure as below:

- a. The EUT was placed on the top of a rotating table 0.8 meters above the ground at a 3 meter semi-anechoic chamber. The table was rotated 360 degrees to determine the position of the highest radiation.
- b. The EUT was set 3 meters away from the interference-receiving antenna, which was mounted on the top of a variable-height antenna tower.
- c. The antenna height is varied from one meter to four meters above the ground to determine the maximum value of the field strength. Both horizontal and vertical polarizations of the antenna are set to make the measurement.
- d. For each suspected emission, the EUT was arranged to its worst case and then the antenna was tuned to heights from 1 meter to 4 meters (for the test frequency of below 30MHz, the antenna was tuned to heights 1 meter) and the rotatable table was turned from 0 degrees to 360 degrees to find the maximum reading.
- e. The test-receiver system was set to Peak Detect Function and Specified Bandwidth with Maximum Hold Mode.
- f. If the emission level of the EUT in peak mode was 10dB lower than the limit specified, then testing could be stopped and the peak values of the EUT would be reported. Otherwise the emissions that did not have 10dB margin would be re-tested one by one using peak, quasi-peak or average method as specified and then reported in a data sheet.

Above 1GHz test procedure as below:

- g. Different between above is the test site, change from Semi- Anechoic Chamber to fully Anechoic Chamber and change form table 0.8 metre to 1.5 metre( Above 18GHz the distance is 1 meter and table is 1.5 metre).
- h. Test the EUT in the lowest channel ,the middle channel ,the Highest channel

Note:

Both horizontal and vertical antenna polarities were tested and performed pretest to three orthogonal axis. The worst case emissions were reported We pretest AC 120V and AC 240V, the worst voltage was AC 120V and the data recording in the report.

### 3.2.3 DEVIATION FROM TEST STANDARD

No deviation

### 3.2.4 TEST SETUP

(A) Radiated Emission Test-Up Frequency Below 30MHz

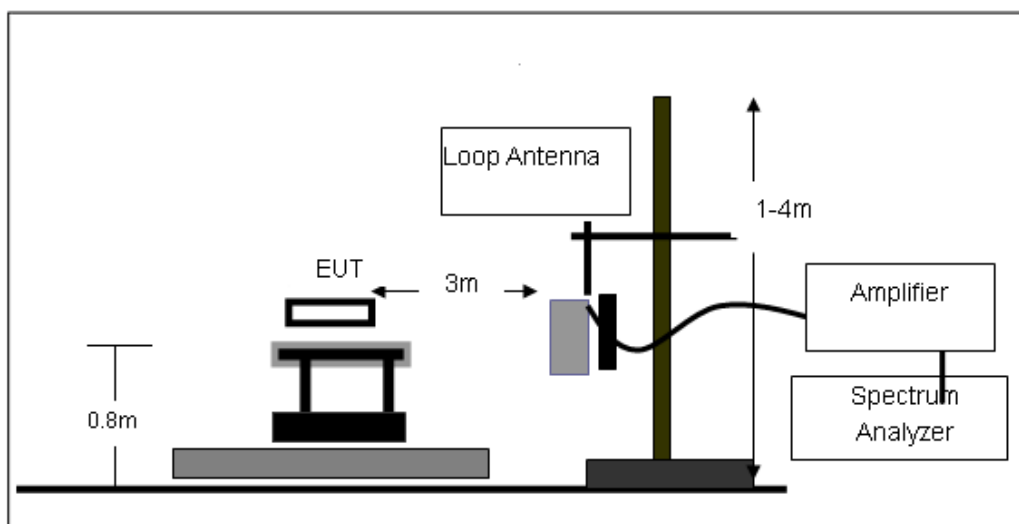



(B) Radiated Emission Test-Up Frequency 30MHz~1GHz

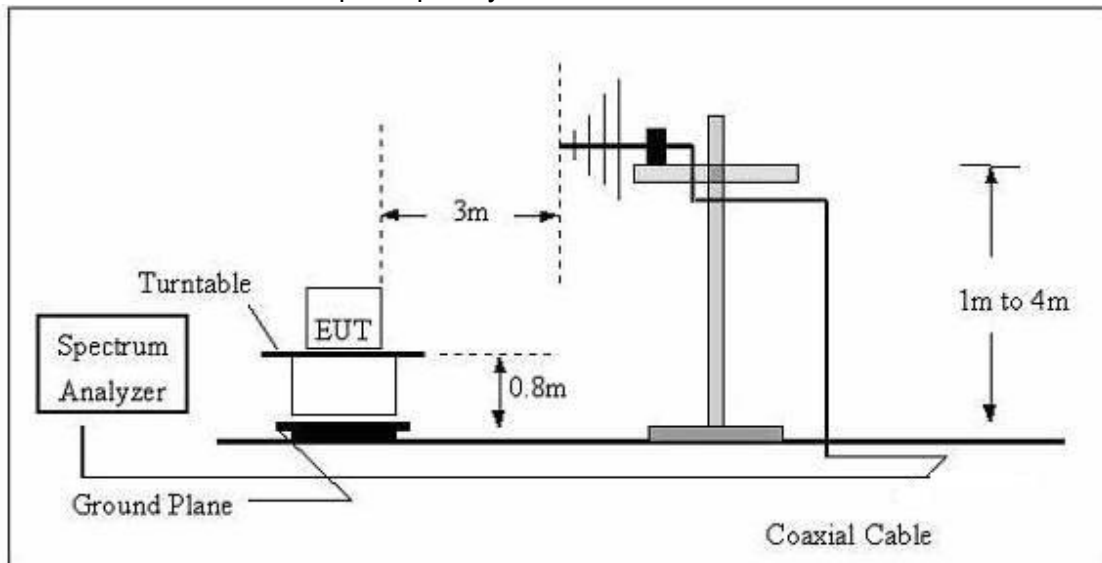

(C) Radiated Emission Test-Up Frequency Above 1GHz

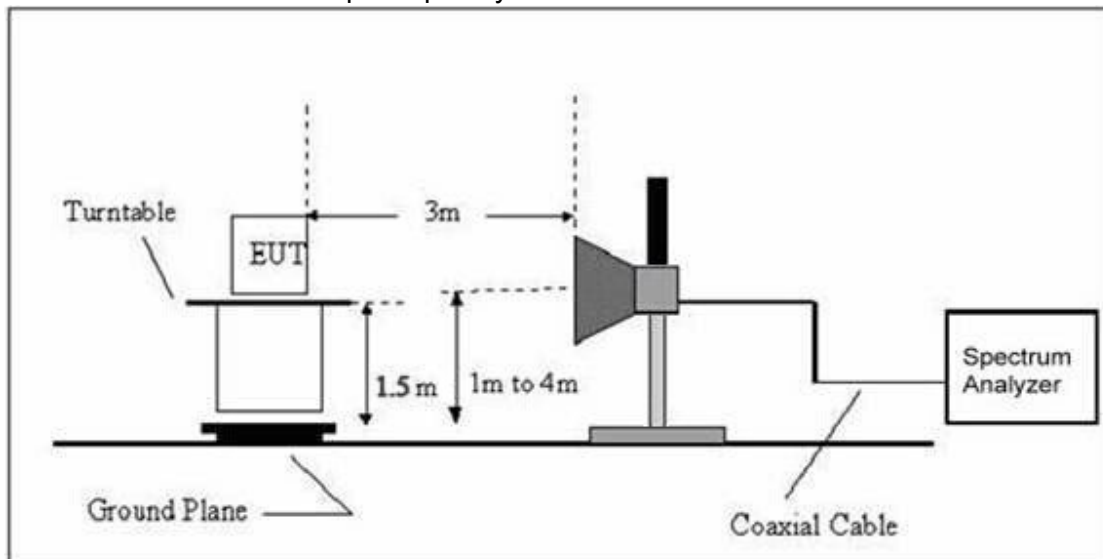

### 3.2.5 EUT OPERATING CONDITIONS

The EUT tested system was configured as the statements of 2.4 Unless otherwise a special operating condition is specified in the follows during the testing.

**3.2.6 TEST RESULTS (BETWEEN 9KHZ – 30 MHZ)**

Temperature:	20°C	Relative Humidity:	48%
Pressure:	1010 hPa	Test Voltage :	DC 12V from adapter
Test Mode :	Mode 5	Polarization :	--

Freq. (MHz)	Reading (dBuV/m)	Limit (dBuV/m)	Margin (dB)	State P/F
--	--	--	--	PASS
--	--	--	--	PASS

**NOTE:**

The amplitude of spurious emissions which are attenuated by more than 20dB below the permissible value has no need to be reported.

Distance extrapolation factor =  $40 \log(\text{specific distance}/\text{test distance})$ (dB);

Limit line = specific limits(dBuv) + distance extrapolation factor.



**3.2.7 TEST RESULTS (BETWEEN 30MHZ – 1GHZ)**

Temperature :	26°C	Relative Humidity :	54%
Pressure :	1010 hPa	Polarization :	Horizontal
Test Voltage :	DC 12V from adapter		
Test Mode :	Mode 5		

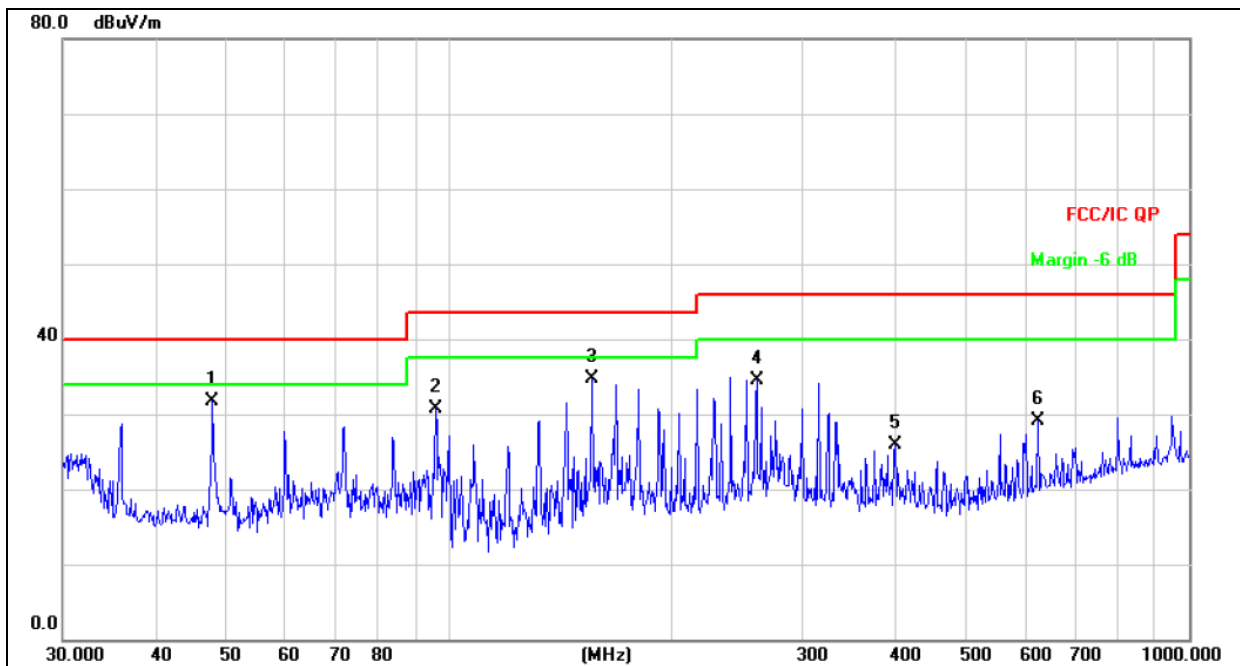

Remark:  
 Factor = Antenna Factor + Cable Loss – Pre-amplifier.  
 All interfaces was connected, and BT TX mode was link.

No.	Mk.	Freq.	Reading Level	Correct Factor	Measurement	Limit	Over	Antenna Height	Table Degree	
		MHz	dBuV	dB/m	dBuV/m	dBuV/m	dB	cm	degree	Comment
1	*	47.8260	41.60	-9.94	31.66	40.00	-8.34	QP		
2		95.7622	47.59	-16.93	30.66	43.50	-12.84	QP		
3		155.9101	47.53	-12.87	34.66	43.50	-8.84	QP		
4		260.1444	48.50	-13.91	34.59	46.00	-11.41	QP		
5		400.4319	36.16	-10.17	25.99	46.00	-20.01	QP		
6		625.0780	34.63	-5.52	29.11	46.00	-16.89	QP		



Temperature :	26°C	Relative Humidity :	54%
Pressure :	1010 hPa	Polarization :	Vertical
Test Voltage :	DC 12V from adapter		
Test Mode :	Mode 5		

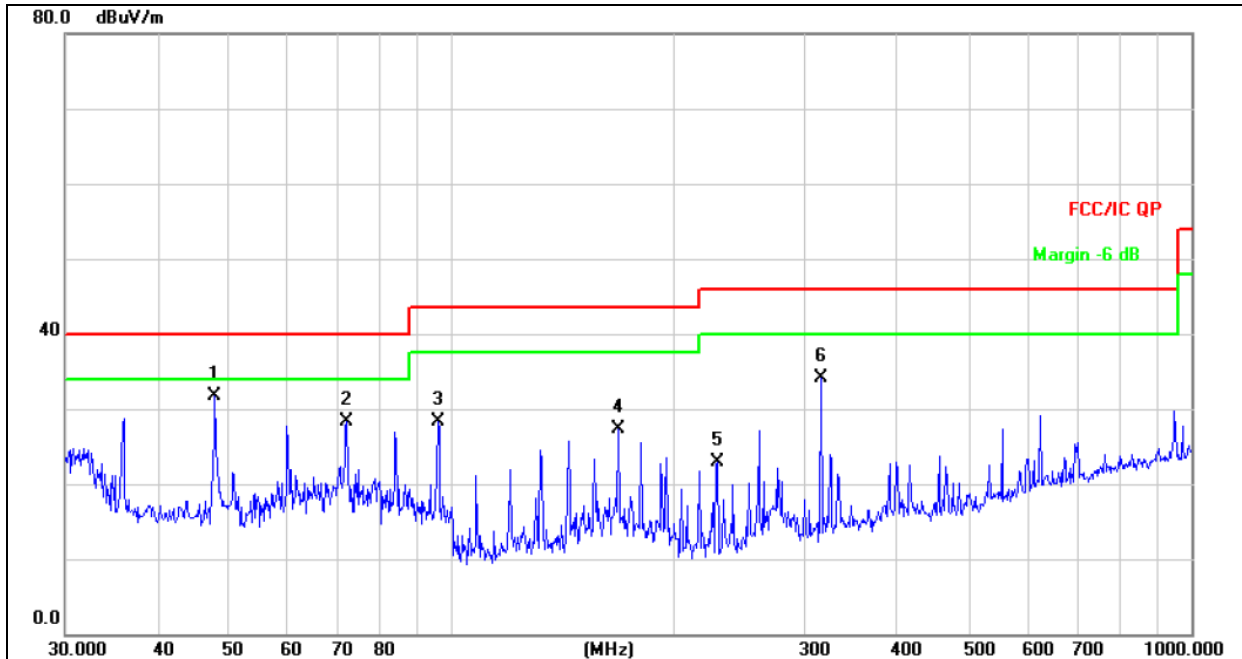

Remark:  
 Factor = Antenna Factor + Cable Loss – Pre-amplifier.  
 All interfaces was connected, and BT TX mode was link.

No.	Mk.	Freq.	Reading Level	Correct Factor	Measurement	Limit	Over	Antenna Height	Table Degree	
		MHz	dBuV	dB/m	dBuV/m	dBuV/m	dB	cm	degree	Comment
1	*	47.8260	41.60	-9.94	31.66	40.00	-8.34	QP		
2		72.0843	43.64	-15.27	28.37	40.00	-11.63	QP		
3		95.7622	45.28	-16.93	28.35	43.50	-15.15	QP		
4		167.8243	40.68	-13.32	27.36	43.50	-16.14	QP		
5		228.4904	38.05	-15.14	22.91	46.00	-23.09	QP		
6		315.4808	46.28	-12.18	34.10	46.00	-11.90	QP		



3.2.8 TEST RESULTS (1GHZ~25GHZ)

802.11b							
Polar (H/V)	Frequency	Meter Reading	Factor	Emission Level	Limits	Margin	Detector Type
	(MHz)	(dBuV)	(dB)	(dBuV/m)	(dBuV/m)	(dB)	
operation frequency:2412							
V	4824.00	42.01	19.36	61.37	74.00	-12.63	PK
V	4824.00	29.47	19.36	48.83	54.00	-5.17	AV
V	7236.00	38.25	17.17	55.42	74.00	-18.58	PK
V	7236.00	27.55	17.17	44.72	54.00	-9.28	AV
V	15450.00	31.83	20.59	52.42	74.00	-21.58	PK
H	4824.00	42.05	19.36	61.41	74.00	-12.59	PK
H	4824.00	29.28	19.36	48.64	54.00	-5.36	AV
H	7236.00	39.01	17.17	56.18	74.00	-17.82	PK
H	7236.00	29.80	17.17	46.97	54.00	-7.03	AV
H	15450.00	30.07	20.59	50.66	74.00	-23.34	PK

Polar (H/V)	Frequency	Meter Reading	Factor	Emission Level	Limits	Margin	Detector Type
	(MHz)	(dBuV)	(dB)	(dBuV/m)	(dBuV/m)	(dB)	
operation frequency:2437							
V	4874.00	42.21	19.42	61.63	74.00	-12.37	PK
V	4874.00	28.95	19.42	48.37	54.00	-5.63	AV
V	7311.00	40.24	17.19	57.43	74.00	-16.57	PK
V	7311.00	26.89	17.19	44.08	54.00	-9.92	AV
V	15450.00	31.83	20.59	52.42	74.00	-21.58	PK
H	4874.00	42.13	19.42	61.55	74.00	-12.45	PK
H	4874.00	26.73	19.42	46.15	54.00	-7.85	AV
H	7311.00	39.30	17.19	56.49	74.00	-17.51	PK
H	7311.00	26.19	17.19	43.38	54.00	-10.62	AV
H	15450.00	30.07	20.59	50.66	74.00	-23.34	PK

Polar (H/V)	Frequency	Meter Reading	Factor	Emission Level	Limits	Margin	Detector Type
	(MHz)	(dBuV)	(dB)	(dBuV/m)	(dBuV/m)	(dB)	
operation frequency:2462							
V	4924.00	41.57	19.47	61.04	74.00	-12.96	PK
V	4924.00	28.55	19.47	48.02	54.00	-5.98	AV
V	7386.00	38.06	17.22	55.28	74.00	-18.72	PK
V	7386.00	27.52	17.22	44.74	54.00	-9.26	AV
V	15450.00	31.63	20.59	52.22	74.00	-21.78	PK
H	4924.00	42.20	19.47	61.67	74.00	-12.33	PK
H	4924.00	28.27	19.47	47.74	54.00	-6.26	AV
H	7386.00	38.27	17.22	55.49	74.00	-18.51	PK
H	7386.00	28.91	17.22	46.13	54.00	-7.87	AV
H	15450.00	29.90	20.59	50.49	74.00	-23.51	PK

Remark:

1. Emission Level = Meter Reading + Factor, Margin= Emission Level - Limit
2. If peak below the average limit, the average emission was no test.
3. The amplitude of spurious emissions which are attenuated by more than 20dB below the permissible value has no need to be reported.



802.11g

Polar (H/V)	Frequency	Meter Reading	Factor	Emission Level	Limits	Margin	Detector Type
	(MHz)	(dBuV)	(dB)	(dBuV/m)	(dBuV/m)	(dB)	
<b>operation frequency:2412</b>							
V	4824.00	39.97	19.36	59.33	74.00	-14.67	PK
V	4824.00	29.43	19.36	48.79	54.00	-5.21	AV
V	7236.00	40.18	17.17	57.35	74.00	-16.65	PK
V	7236.00	29.50	17.17	46.67	54.00	-7.33	AV
V	15450.00	31.79	20.59	52.38	74.00	-21.62	PK
H	4824.00	40.01	19.36	59.37	74.00	-14.63	PK
H	4824.00	29.24	19.36	48.60	54.00	-5.40	AV
H	7236.00	39.95	17.17	57.12	74.00	-16.88	PK
H	7236.00	29.76	17.17	46.93	54.00	-7.07	AV
H	15450.00	30.04	20.59	50.63	74.00	-23.37	PK

Polar (H/V)	Frequency	Meter Reading	Factor	Emission Level	Limits	Margin	Detector Type
	(MHz)	(dBuV)	(dB)	(dBuV/m)	(dBuV/m)	(dB)	
<b>operation frequency:2437</b>							
V	4874.00	42.15	19.42	61.57	74.00	-12.43	PK
V	4874.00	28.91	19.42	48.33	54.00	-5.67	AV
V	7311.00	40.19	17.19	57.38	74.00	-16.62	PK
V	7311.00	26.85	17.19	44.04	54.00	-9.96	AV
V	15450.00	31.79	20.59	52.38	74.00	-21.62	PK
H	4874.00	42.07	19.42	61.49	74.00	-12.51	PK
H	4874.00	26.70	19.42	46.12	54.00	-7.88	AV
H	7311.00	39.25	17.19	56.44	74.00	-17.56	PK
H	7311.00	26.16	17.19	43.35	54.00	-10.65	AV
H	15450.00	30.04	20.59	50.63	74.00	-23.37	PK

Polar (H/V)	Frequency	Meter Reading	Factor	Emission Level	Limits	Margin	Detector Type
	(MHz)	(dBuV)	(dB)	(dBuV/m)	(dBuV/m)	(dB)	
<b>operation frequency:2462</b>							
V	4924.00	41.52	19.47	60.99	74.00	-13.01	PK
V	4924.00	28.51	19.47	47.98	54.00	-6.02	AV
V	7386.00	38.01	17.22	55.23	74.00	-18.77	PK
V	7386.00	27.48	17.22	44.70	54.00	-9.30	AV
V	15450.00	31.59	20.59	52.18	74.00	-21.82	PK
H	4924.00	42.14	19.47	61.61	74.00	-12.39	PK
H	4924.00	28.23	19.47	47.70	54.00	-6.30	AV
H	7386.00	38.22	17.22	55.44	74.00	-18.56	PK
H	7386.00	28.87	17.22	46.09	54.00	-7.91	AV
H	15450.00	29.86	20.59	50.45	74.00	-23.55	PK

**Remark:**

1. Emission Level = Meter Reading + Factor, Margin= Emission Level - Limit
2. If peak below the average limit, the average emission was no test.
3. The amplitude of spurious emissions which are attenuated by more than 20dB below the permissible value has no need to be reported.



802.11n(20MHz)

Polar (H/V)	Frequency	Meter Reading	Factor	Emission Level	Limits	Margin	Detector Type
	(MHz)	(dBuV)	(dB)	(dBuV/m)	(dBuV/m)	(dB)	
<b>operation frequency:2412</b>							
V	4824.00	40.10	19.36	59.46	74.00	-14.54	PK
V	4824.00	29.53	19.36	48.89	54.00	-5.11	AV
V	7236.00	40.31	17.17	57.48	74.00	-16.52	PK
V	7236.00	29.60	17.17	46.77	54.00	-7.23	AV
V	15450.00	31.89	20.59	52.48	74.00	-21.52	PK
H	4824.00	40.14	19.36	59.50	74.00	-14.50	PK
H	4824.00	29.34	19.36	48.70	54.00	-5.30	AV
H	7236.00	40.08	17.17	57.25	74.00	-16.75	PK
H	7236.00	29.86	17.17	47.03	54.00	-6.97	AV
H	15450.00	30.13	20.59	50.72	74.00	-23.28	PK

Polar (H/V)	Frequency	Meter Reading	Factor	Emission Level	Limits	Margin	Detector Type
	(MHz)	(dBuV)	(dB)	(dBuV/m)	(dBuV/m)	(dB)	
<b>operation frequency:2437</b>							
V	4874.00	42.29	19.42	61.71	74.00	-12.29	PK
V	4874.00	29.01	19.42	48.43	54.00	-5.57	AV
V	7311.00	40.32	17.19	57.51	74.00	-16.49	PK
V	7311.00	26.94	17.19	44.13	54.00	-9.87	AV
V	15450.00	31.89	20.59	52.48	74.00	-21.52	PK
H	4874.00	42.21	19.42	61.63	74.00	-12.37	PK
H	4874.00	26.78	19.42	46.20	54.00	-7.80	AV
H	7311.00	39.38	17.19	56.57	74.00	-17.43	PK
H	7311.00	26.24	17.19	43.43	54.00	-10.57	AV
H	15450.00	30.13	20.59	50.72	74.00	-23.28	PK

Polar (H/V)	Frequency	Meter Reading	Factor	Emission Level	Limits	Margin	Detector Type
	(MHz)	(dBuV)	(dB)	(dBuV/m)	(dBuV/m)	(dB)	
<b>operation frequency:2462</b>							
V	4924.00	41.65	19.47	61.12	74.00	-12.88	PK
V	4924.00	28.60	19.47	48.07	54.00	-5.93	AV
V	7386.00	38.13	17.22	55.35	74.00	-18.65	PK
V	7386.00	27.57	17.22	44.79	54.00	-9.21	AV
V	15450.00	31.69	20.59	52.28	74.00	-21.72	PK
H	4924.00	42.28	19.47	61.75	74.00	-12.25	PK
H	4924.00	28.32	19.47	47.79	54.00	-6.21	AV
H	7386.00	38.34	17.22	55.56	74.00	-18.44	PK
H	7386.00	28.97	17.22	46.19	54.00	-7.81	AV
H	15450.00	29.96	20.59	50.55	74.00	-23.45	PK

**Remark:**

1. Emission Level = Meter Reading + Factor, Margin= Emission Level - Limit
2. If peak below the average limit, the average emission was no test.
3. The amplitude of spurious emissions which are attenuated by more than 20dB below the permissible value has no need to be reported.



802.11n(40MHz)

Polar (H/V)	Frequency	Meter Reading	Factor	Emission Level	Limits	Margin	Detector Type
	(MHz)	(dBuV)	(dB)	(dBuV/m)	(dBuV/m)	(dB)	
<b>operation frequency:2422</b>							
V	4844.000	39.78	19.37	59.15	74.00	-14.85	PK
V	4844.000	29.29	19.37	48.66	54.00	-5.34	AV
V	7266.000	39.98	17.18	57.16	74.00	-16.84	PK
V	7266.000	29.36	17.18	46.54	54.00	-7.46	AV
V	15450.00	31.63	20.59	52.22	74.00	-21.78	PK
H	4844.000	39.82	19.37	59.19	74.00	-14.81	PK
H	4844.000	29.10	19.37	48.47	54.00	-5.53	AV
H	7266.000	39.76	17.18	56.94	74.00	-17.06	PK
H	7266.000	29.62	17.18	46.80	54.00	-7.20	AV
H	15450.00	29.89	20.59	50.48	74.00	-23.52	PK

Polar (H/V)	Frequency	Meter Reading	Factor	Emission Level	Limits	Margin	Detector Type
	(MHz)	(dBuV)	(dB)	(dBuV/m)	(dBuV/m)	(dB)	
<b>operation frequency:2437</b>							
V	4874.00	41.87	19.42	61.29	74.00	-12.71	PK
V	4874.00	28.71	19.42	48.13	54.00	-5.87	AV
V	7311.00	39.91	17.19	57.10	74.00	-16.90	PK
V	7311.00	26.67	17.19	43.86	54.00	-10.14	AV
V	15450.00	31.57	20.59	52.16	74.00	-21.84	PK
H	4874.00	41.79	19.42	61.21	74.00	-12.79	PK
H	4874.00	26.51	19.42	45.93	54.00	-8.07	AV
H	7311.00	38.98	17.19	56.17	74.00	-17.83	PK
H	7311.00	25.98	17.19	43.17	54.00	-10.83	AV
H	15450.00	29.83	20.59	50.42	74.00	-23.58	PK

Polar (H/V)	Frequency	Meter Reading	Factor	Emission Level	Limits	Margin	Detector Type
	(MHz)	(dBuV)	(dB)	(dBuV/m)	(dBuV/m)	(dB)	
<b>operation frequency:2452</b>							
V	4904.00	41.31	19.44	60.75	74.00	-13.25	PK
V	4904.00	28.37	19.44	47.81	54.00	-6.19	AV
V	7356.00	37.82	17.21	55.03	74.00	-18.97	PK
V	7356.00	27.35	17.21	44.56	54.00	-9.44	AV
V	15450.00	31.44	20.59	52.03	74.00	-21.97	PK
H	4904.00	41.94	19.44	61.38	74.00	-12.62	PK
H	4904.00	28.09	19.44	47.53	54.00	-6.47	AV
H	7356.00	38.03	17.21	55.24	74.00	-18.76	PK
H	7356.00	28.73	17.21	45.94	54.00	-8.06	AV
H	15450.00	29.72	20.59	50.31	74.00	-23.69	PK

**Remark:**

1. Emission Level = Meter Reading + Factor, Margin= Emission Level - Limit
2. If peak below the average limit, the average emission was no test.
3. The amplitude of spurious emissions which are attenuated by more than 20dB below the permissible value has no need to be reported.





For Conducted  
Antenna 1  
802.11b  
2412MHz

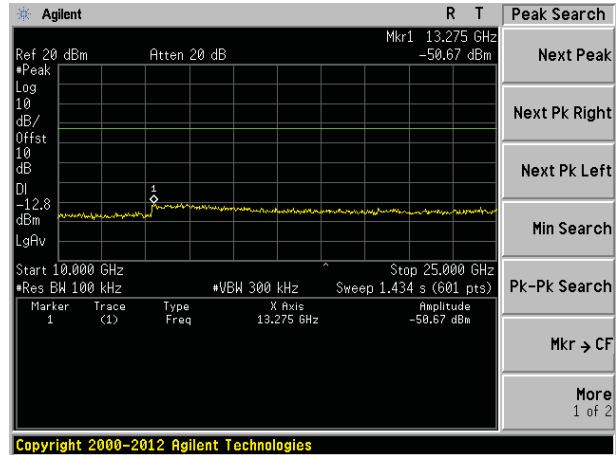
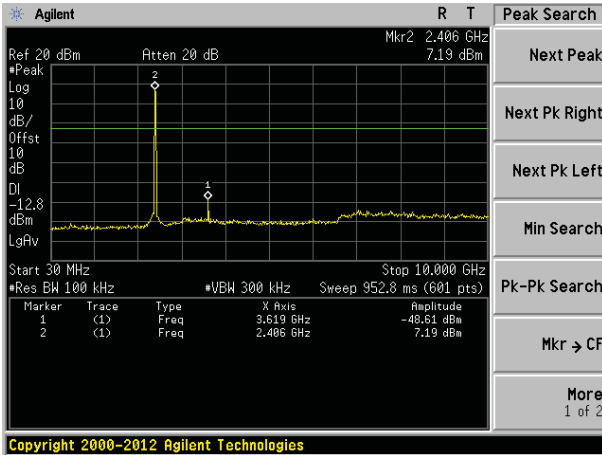

2437MHz

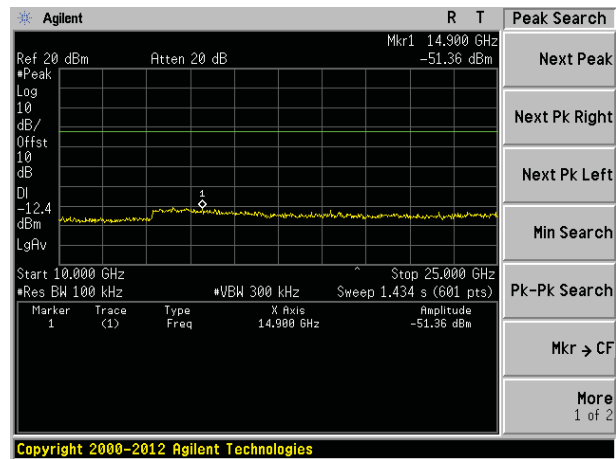
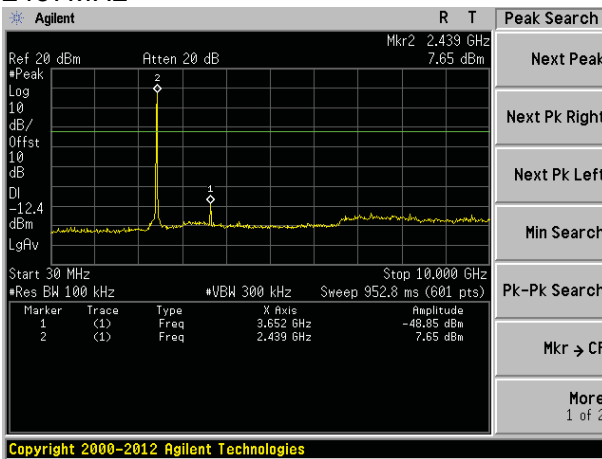

2462MHz

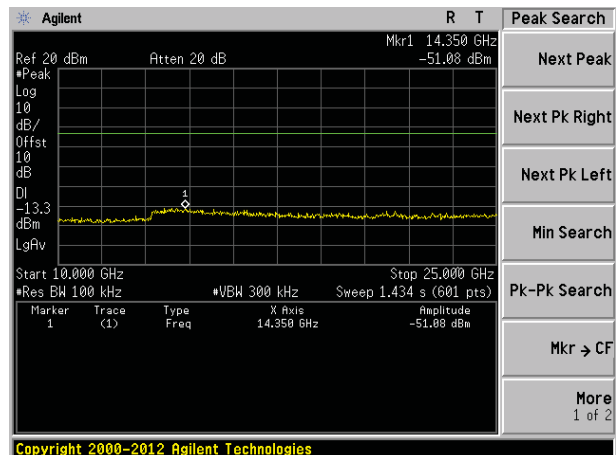
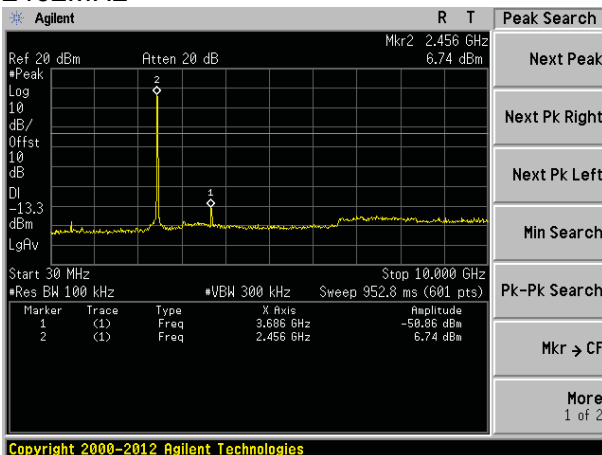



802.11g  
2412MHz

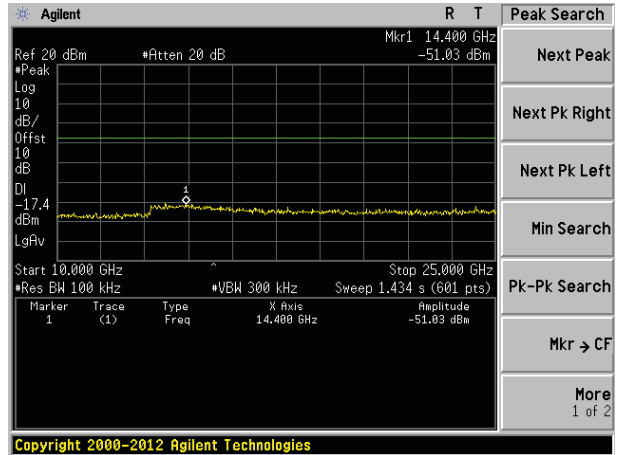
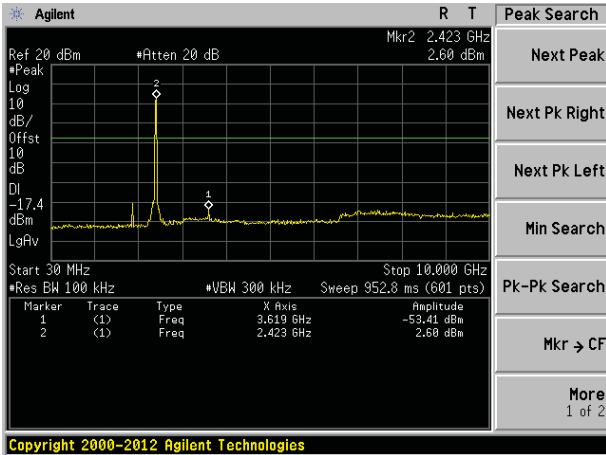

2437MHz

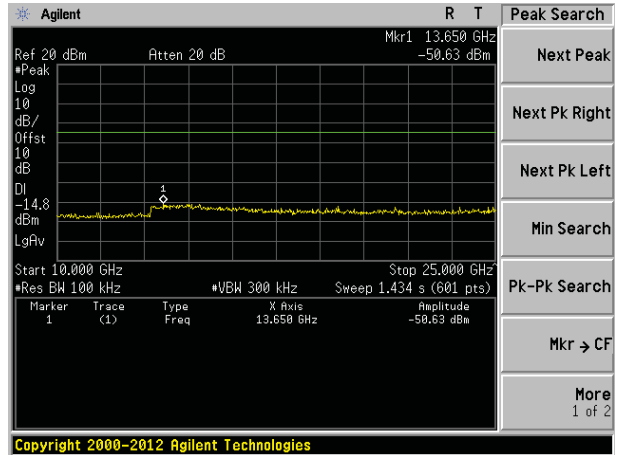
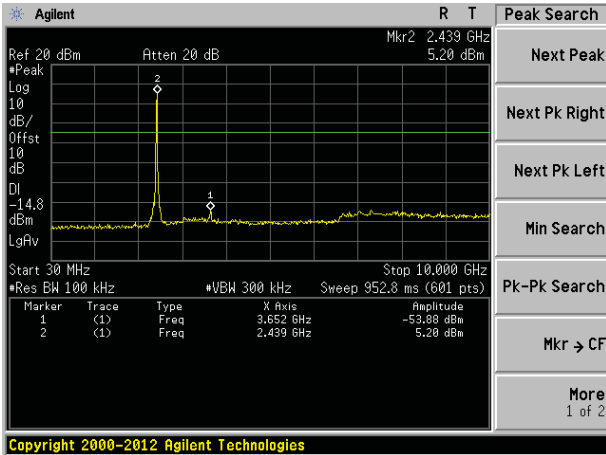

2462MHz

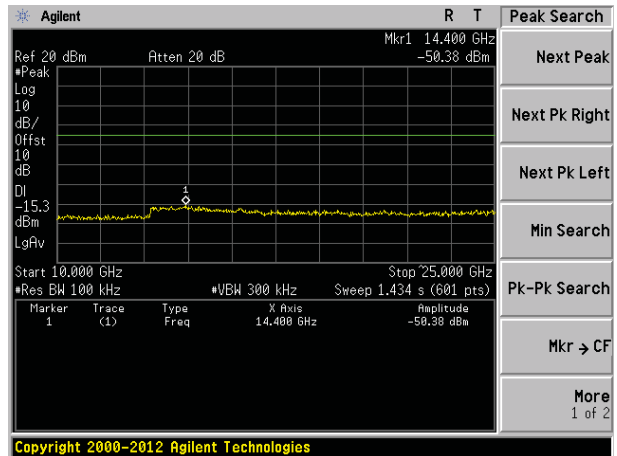
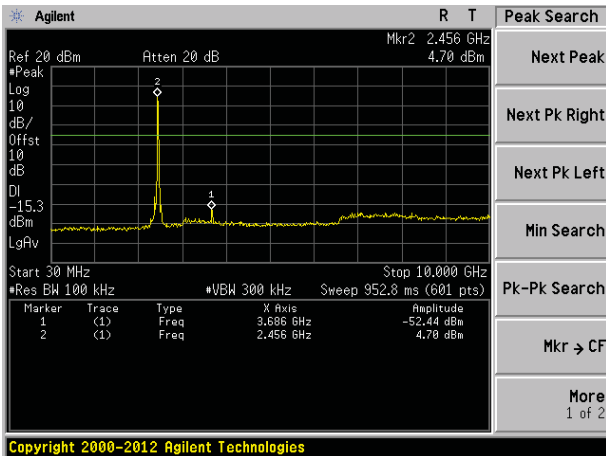



802.11n 20MHz  
2412MHz

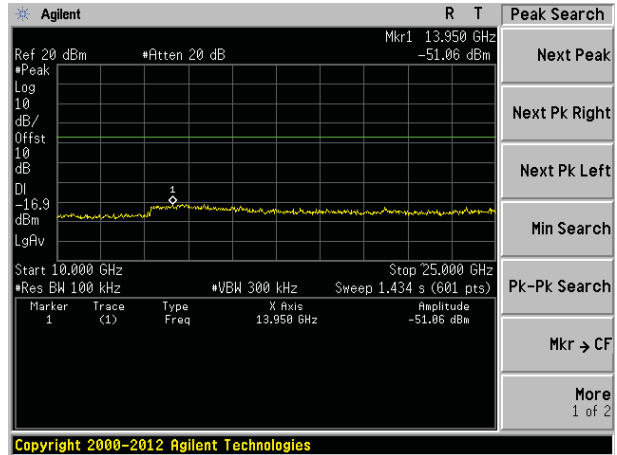
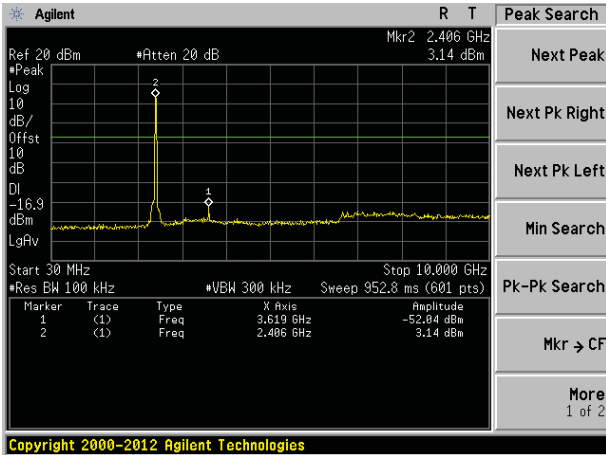

2437MHz

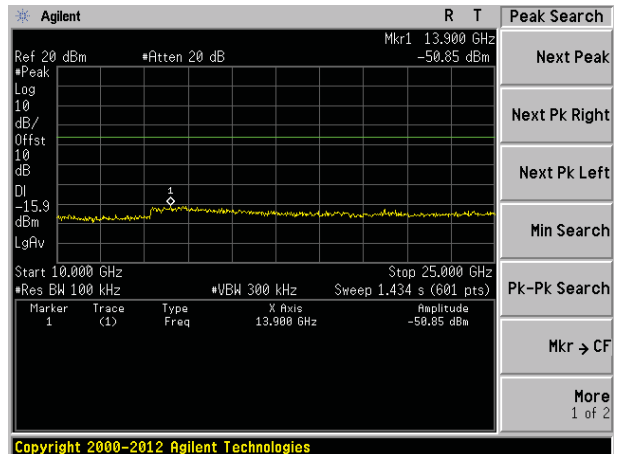
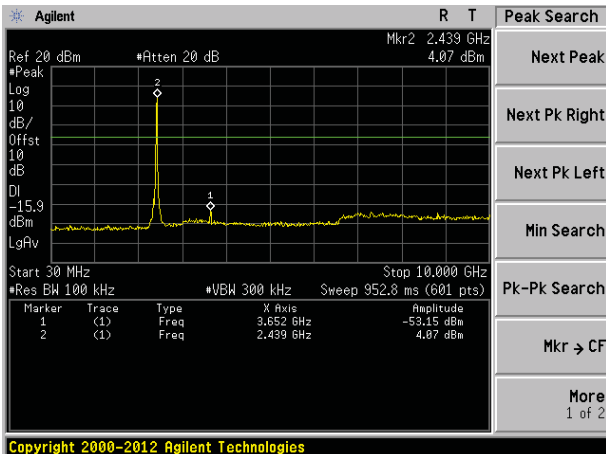

2462MHz

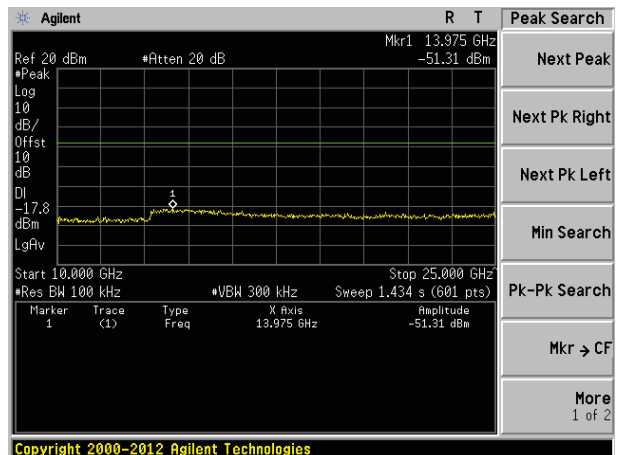
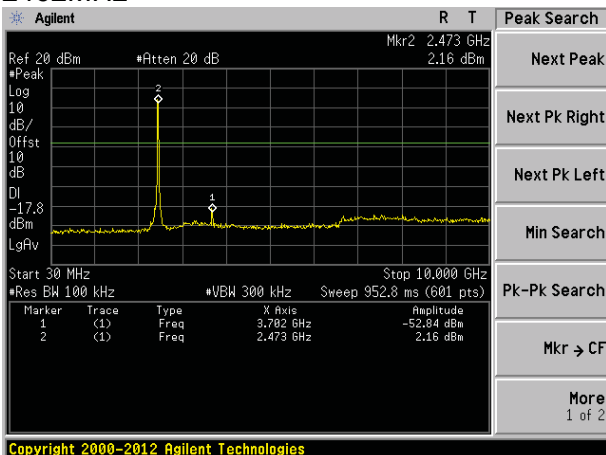



802.11n 40MHz  
2412MHz

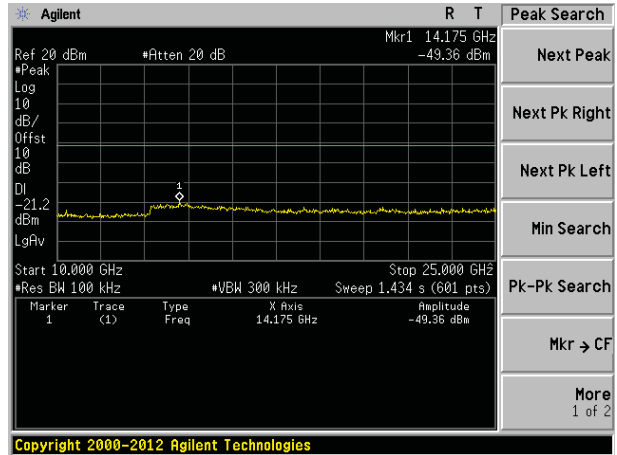
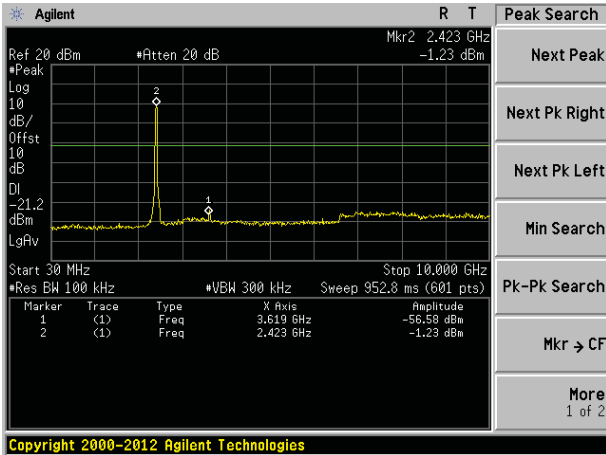

2437MHz

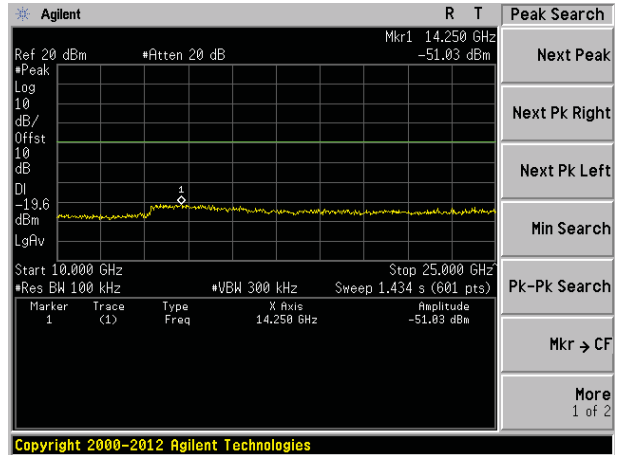
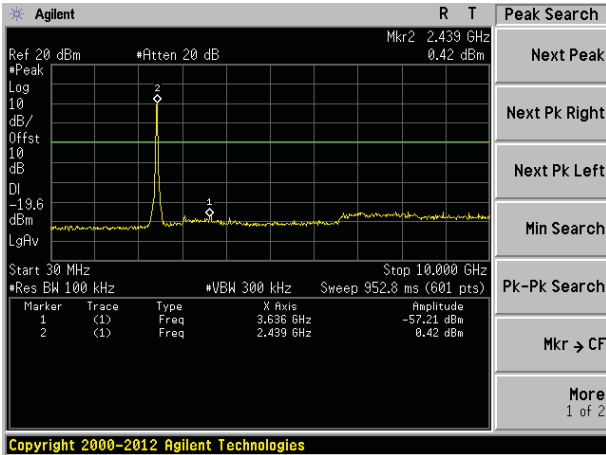

2462MHz

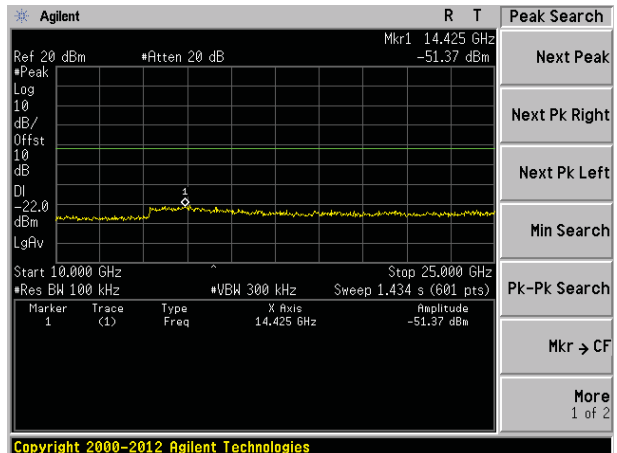
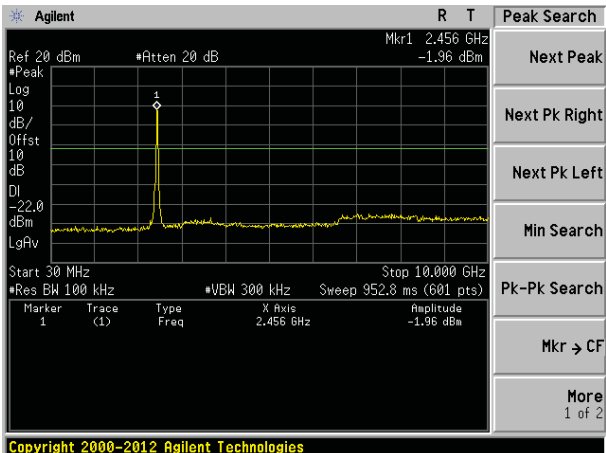



Antenna 2  
802.11b  
2412MHz

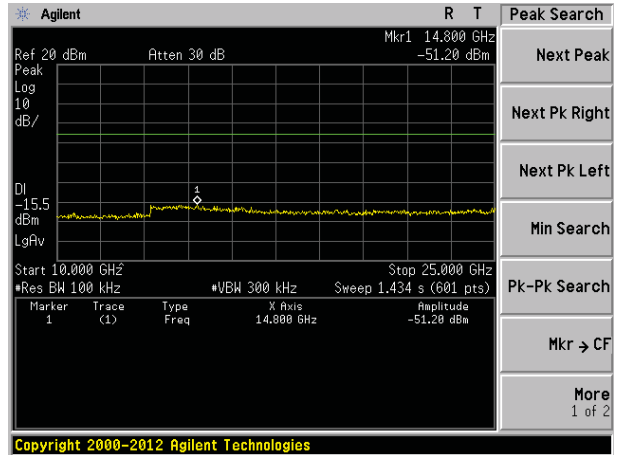
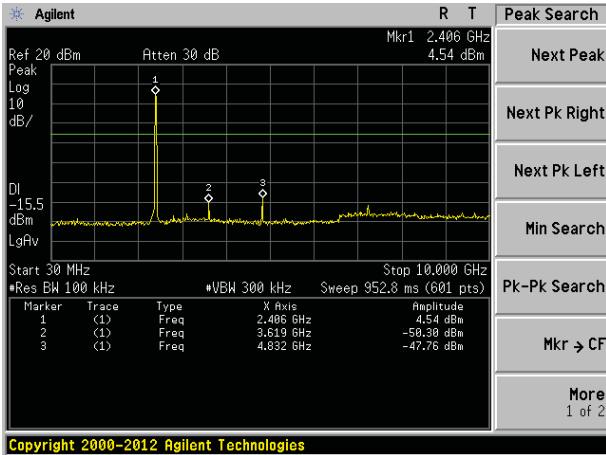

2437MHz

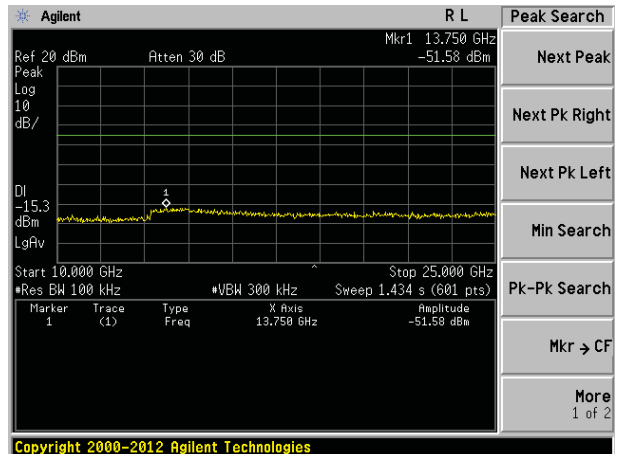
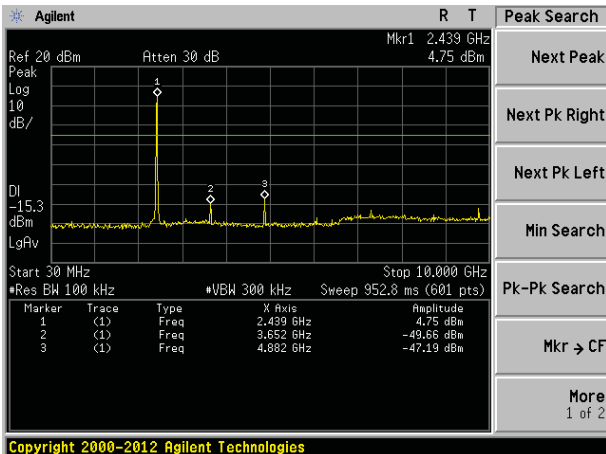

2462MHz

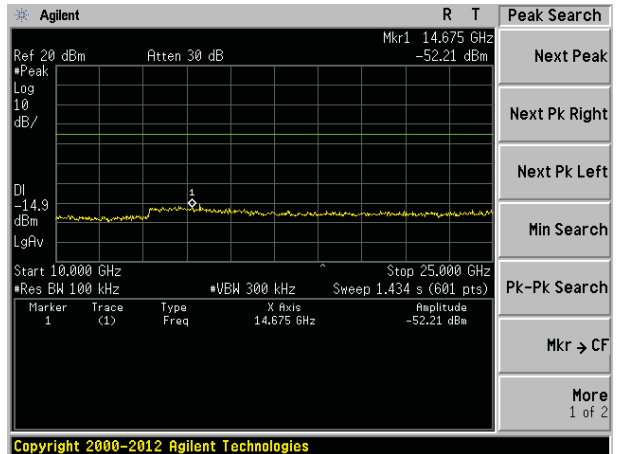
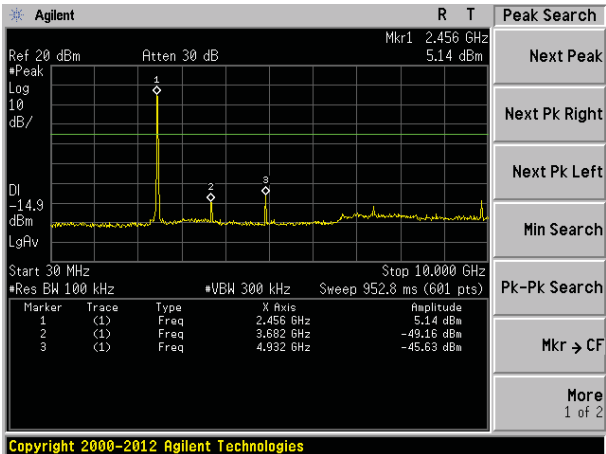



### 802.11g 2412MHz

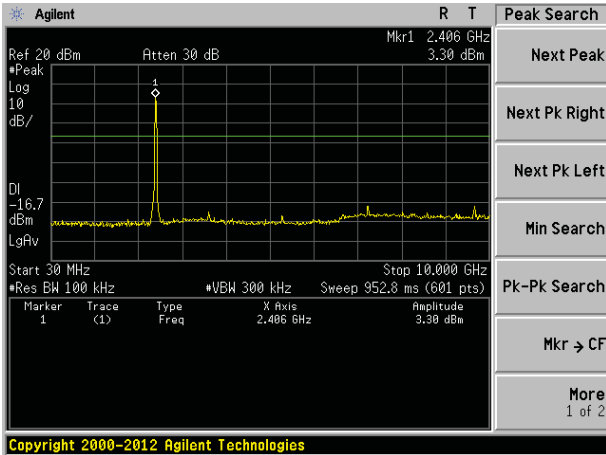

Copyright 2000-2012 Agilent Technologies

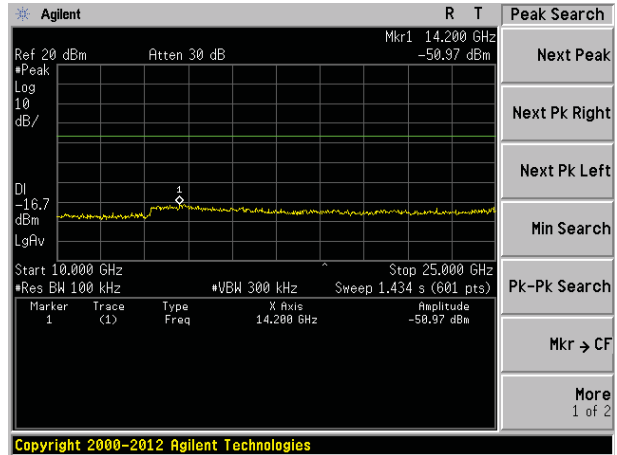

Copyright 2000-2012 Agilent Technologies

### 2437MHz

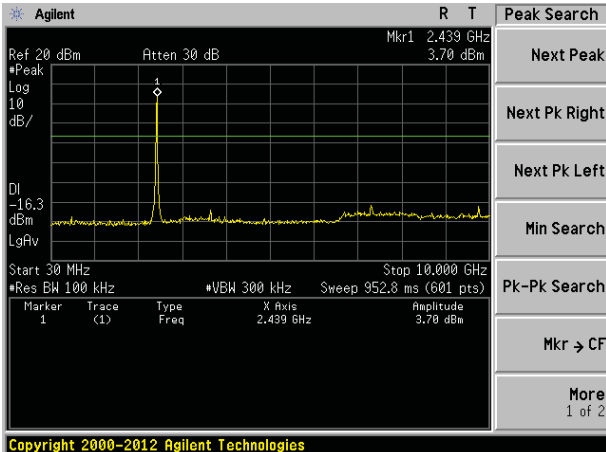

Copyright 2000-2012 Agilent Technologies

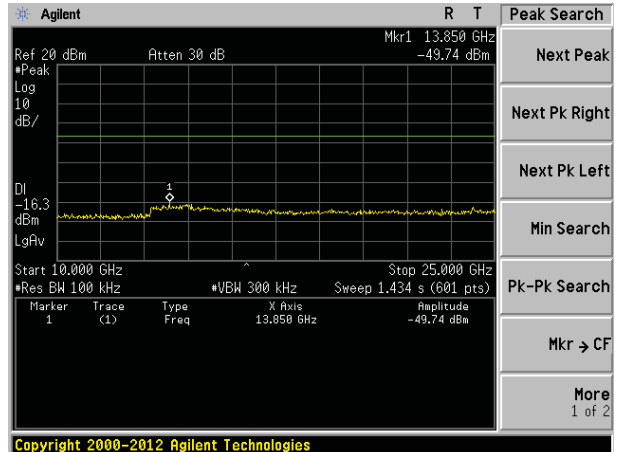

Copyright 2000-2012 Agilent Technologies

### 2462MHz

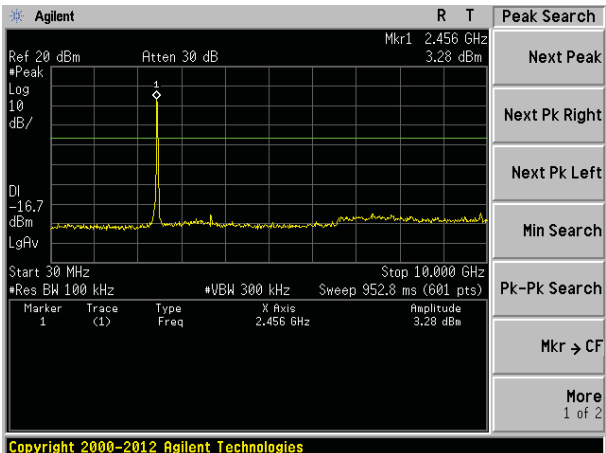

Copyright 2000-2012 Agilent Technologies

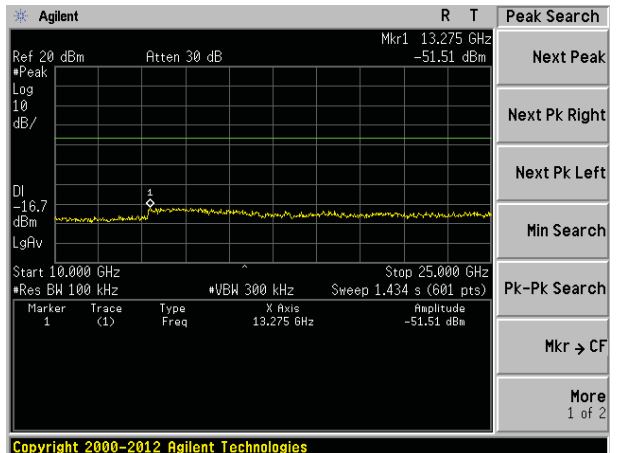

Copyright 2000-2012 Agilent Technologies



802.11n 20MHz  
2412MHz

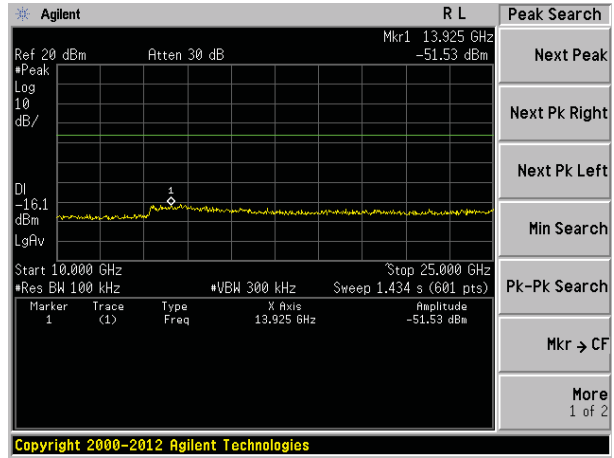
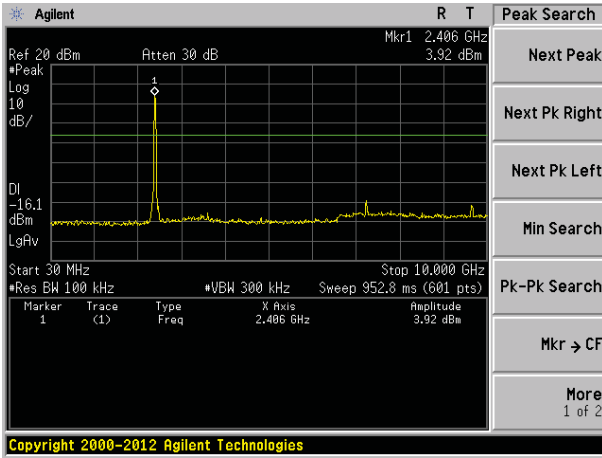

2437MHz

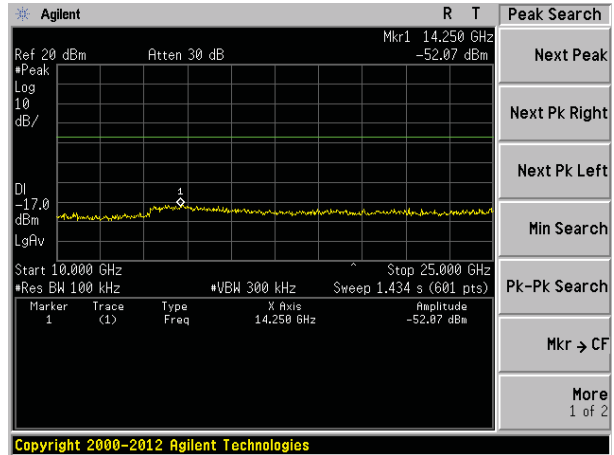
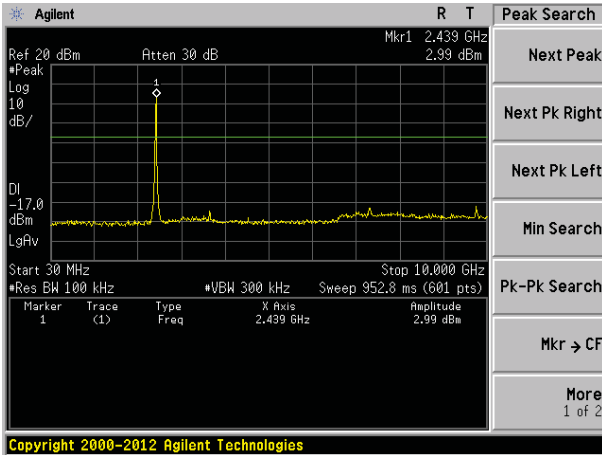

2462MHz

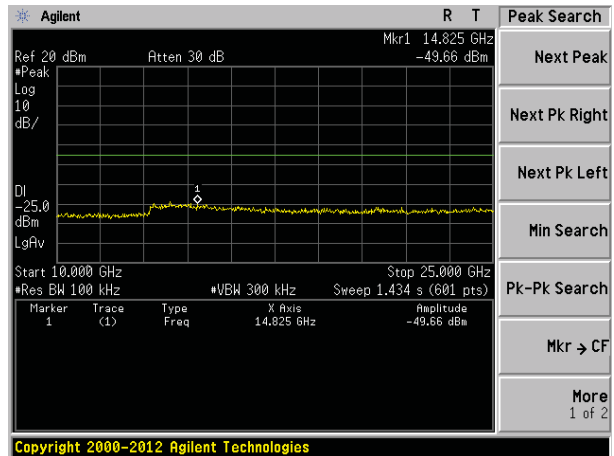
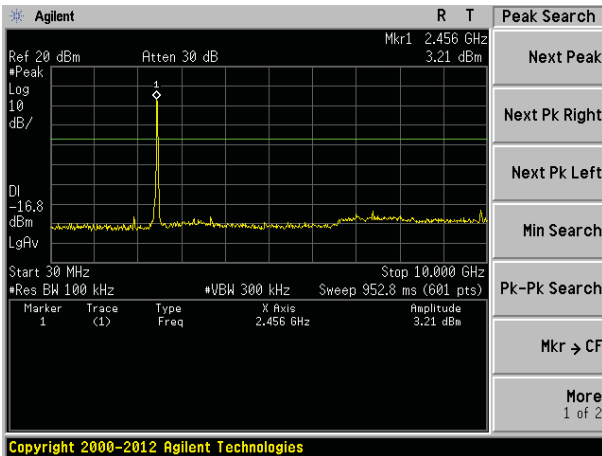



802.11n 40MHz  
2412MHz

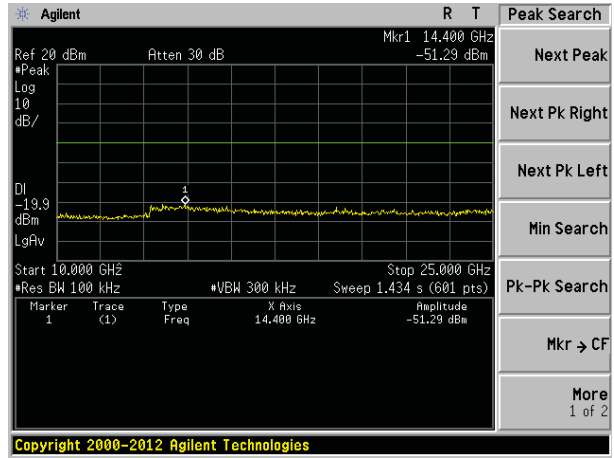
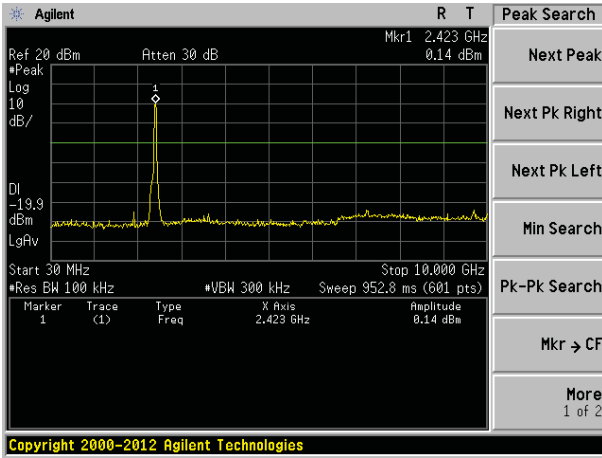

2437MHz

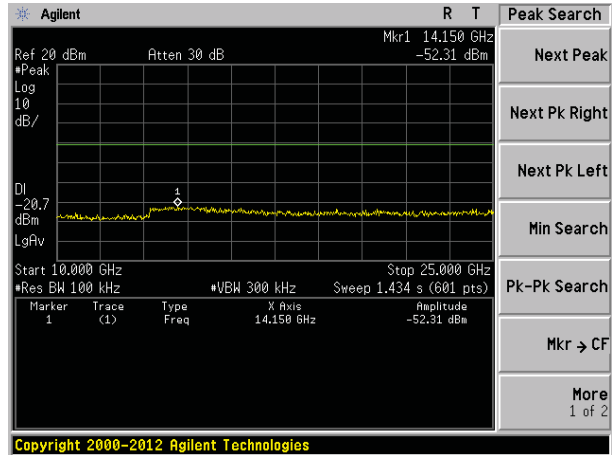
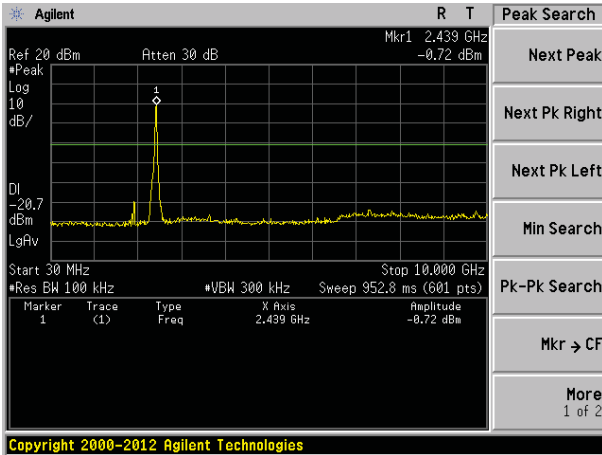

2462MHz

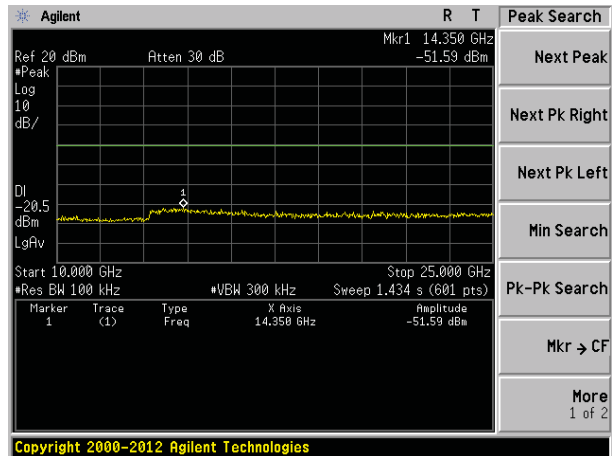
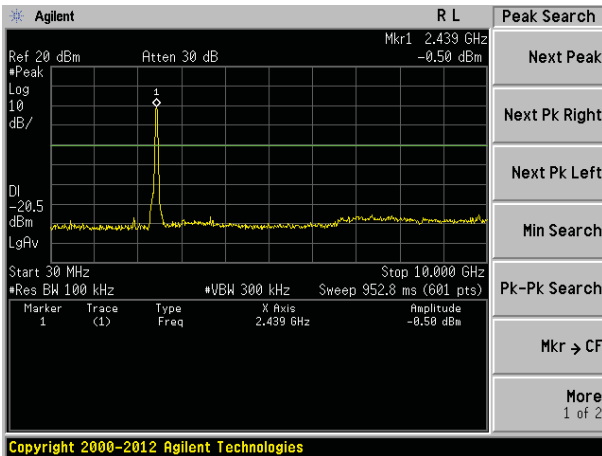





### 3.3 RADIATED BAND EMISSION MEASUREMENT

#### 3.3.1 TEST REQUIREMENT:

FCC Part15 C Section 15.209 and 15.205

LIMITS OF RADIATED EMISSION MEASUREMENT (Above 1000MHz)

FREQUENCY (MHz)	Class B (dBuV/m) (at 3M)	
	PEAK	AVERAGE
Above 1000	74	54

Notes:

- (1) The limit for radiated test was performed according to FCC PART 15C.
- (2) The tighter limit applies at the band edges.
- (3) Emission level (dBuV/m)=20log Emission level (uV/m).

Spectrum Parameter	Setting
Attenuation	Auto
Start Frequency	2300MHz
Stop Frequency	2520
RB / VB (emission in restricted band)	1 MHz / 1 MHz for Peak, 1 MHz / 10Hz for Average

#### 3.3.2 TEST PROCEDURE

Above 1GHz test procedure as below:

- a. 1. The EUT was placed on the top of a rotating table 1.5 meters above the ground at a 3 meter camber. The table was rotated 360 degrees to determine the position of the highest radiation.
- b. The EUT was set 3 meters away from the interference-receiving antenna, which was mounted on the top of a variable-height antenna tower.
- c. The antenna height is varied from one meter to four meters above the ground to determine the maximum value of the field strength. Both horizontal and vertical polarizations of the antenna are set to make the measurement.
- d. For each suspected emission, the EUT was arranged to its worst case and then the antenna was tuned to heights from 1 meter to 4 meters and the rota table was turned from 0 degrees to 360 degrees to find the maximum reading.
- e. The test-receiver system was set to Peak Detect Function and Specified Bandwidth with Maximum Hold Mode.
- f. If the emission level of the EUT in peak mode was 10dB lower than the limit specified, then testing could be stopped and the peak values of the EUT would be reported. Otherwise the emissions that did not have 10dB margin would be re-tested one by one using peak, quasi-peak or average method as specified and then reported in a data sheet.
- g. Test the EUT in the lowest channel,the Highest channel

Note:

Both horizontal and vertical antenna polarities were tested and performed pretest to three orthogonal axis. The worst case emissions were reported

### 3.3.3 DEVIATION FROM TEST STANDARD

No deviation

### 3.3.4 TEST SETUP

Radiated Emission Test-Up Frequency Above 1GHz

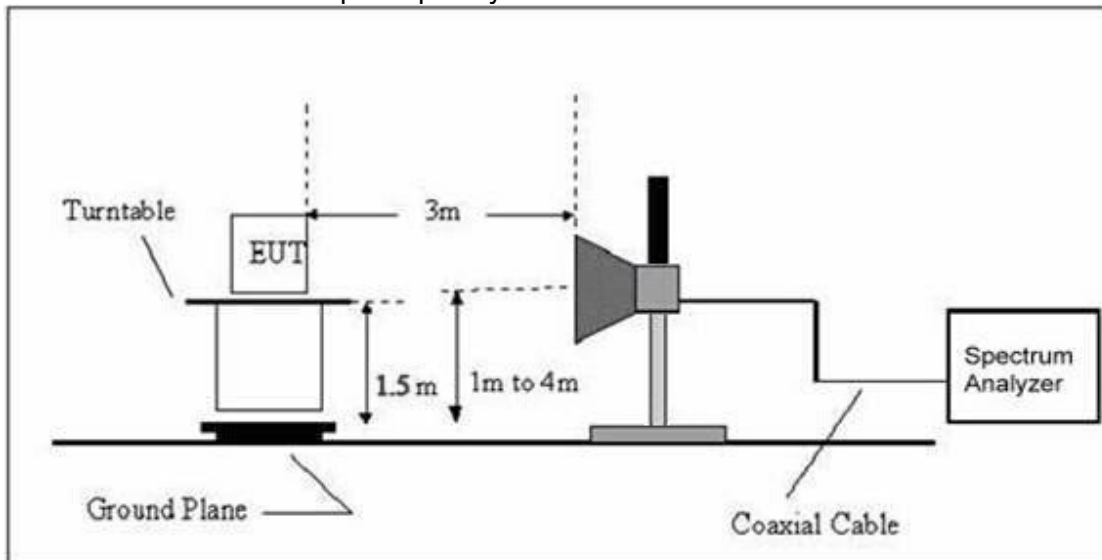

### 3.3.5 EUT OPERATING CONDITIONS

The EUT tested system was configured as the statements of 2.3 Unless otherwise a special operating condition is specified in the follows during the testing.



3.3.6 TEST RESULT

802.11b

Polar (H/V)	Frequency	Meter Reading	Factor	Emission Level	Limits	Margin	Detector Type
	(MHz)	(dBuV)	(dB)	(dBuV/m)	(dBuV/m)	(dB)	
<b>operation frequency:2412</b>							
V	2390.00	38.05	13.83	51.88	74.00	-22.12	PK
V	2390.00	26.43	13.83	40.26	54.00	-13.74	AV
V	2400.00	38.26	13.85	52.11	74.00	-21.89	PK
V	2400.00	25.99	13.85	39.84	54.00	-14.16	AV
H	2390.00	38.35	13.83	52.18	74.00	-21.82	PK
H	2390.00	26.46	13.83	40.29	54.00	-13.71	AV
V	2400.00	38.21	13.85	52.06	74.00	-21.94	PK
V	2400.00	26.40	13.85	40.25	54.00	-13.75	AV

Polar (H/V)	Frequency	Meter Reading	Factor	Emission Level	Limits	Margin	Detector Type
	(MHz)	(dBuV)	(dB)	(dBuV/m)	(dBuV/m)	(dB)	
<b>operation frequency:2462</b>							
V	2483.50	38.26	14.02	52.28	74.00	-21.72	PK
V	2483.50	26.68	14.02	40.70	54.00	-13.30	AV
V	2500.00	38.20	14.06	52.26	74.00	-21.74	PK
V	2500.00	26.10	14.06	40.16	54.00	-13.84	AV
H	2483.50	38.39	14.02	52.41	74.00	-21.59	PK
H	2483.50	26.72	14.02	40.74	54.00	-13.26	AV
H	2500.00	38.00	14.06	52.06	74.00	-21.94	PK
H	2500.00	26.98	14.06	41.04	54.00	-12.96	AV

**Remark:**

1. Emission Level = Meter Reading + Factor, Margin= Emission Level - Limit
2. If peak below the average limit, the average emission was no test.
3. The amplitude of spurious emissions which are attenuated by more than 20dB below the permissible value has no need to be reported.



802.11b

Polar (H/V)	Frequency	Meter Reading	Factor	Emission Level	Limits	Margin	Detector Type
	(MHz)	(dBuV)	(dB)	(dBuV/m)	(dBuV/m)	(dB)	
<b>operation frequency:2412</b>							
V	2390.00	37.74	13.83	51.57	74.00	-22.43	PK
V	2390.00	26.21	13.83	40.04	54.00	-13.96	AV
V	2400.00	37.95	13.85	51.80	74.00	-22.20	PK
V	2400.00	25.79	13.85	39.64	54.00	-14.36	AV
H	2390.00	38.04	13.83	51.87	74.00	-22.13	PK
H	2390.00	26.24	13.83	40.07	54.00	-13.93	AV
V	2400.00	37.90	13.85	51.75	74.00	-22.25	PK
V	2400.00	26.18	13.85	40.03	54.00	-13.97	AV

Polar (H/V)	Frequency	Meter Reading	Factor	Emission Level	Limits	Margin	Detector Type
	(MHz)	(dBuV)	(dB)	(dBuV/m)	(dBuV/m)	(dB)	
<b>operation frequency:2462</b>							
V	2483.50	37.95	14.02	51.97	74.00	-22.03	PK
V	2483.50	26.46	14.02	40.48	54.00	-13.52	AV
V	2500.00	37.89	14.06	51.95	74.00	-22.05	PK
V	2500.00	25.89	14.06	39.95	54.00	-14.05	AV
H	2483.50	38.08	14.02	52.10	74.00	-21.90	PK
H	2483.50	26.50	14.02	40.52	54.00	-13.48	AV
H	2500.00	37.69	14.06	51.75	74.00	-22.25	PK
H	2500.00	26.76	14.06	40.82	54.00	-13.18	AV

**Remark:**

1. Emission Level = Meter Reading + Factor, Margin= Emission Level - Limit
2. If peak below the average limit, the average emission was no test.
3. The amplitude of spurious emissions which are attenuated by more than 20dB below the permissible value has no need to be reported.



**802.11n(20MHz)**

Polar (H/V)	Frequency	Meter Reading	Factor	Emission Level	Limits	Margin	Detector Type
	(MHz)	(dBuV)	(dB)	(dBuV/m)	(dBuV/m)	(dB)	
<b>operation frequency:2412</b>							
V	2390.00	37.85	13.83	51.68	74.00	-22.32	PK
V	2390.00	26.29	13.83	40.12	54.00	-13.88	AV
V	2400.00	38.06	13.85	51.91	74.00	-22.09	PK
V	2400.00	25.86	13.85	39.71	54.00	-14.29	AV
H	2390.00	38.15	13.83	51.98	74.00	-22.02	PK
H	2390.00	26.32	13.83	40.15	54.00	-13.85	AV
V	2400.00	38.01	13.85	51.86	74.00	-22.14	PK
V	2400.00	26.26	13.85	40.11	54.00	-13.89	AV

Polar (H/V)	Frequency	Meter Reading	Factor	Emission Level	Limits	Margin	Detector Type
	(MHz)	(dBuV)	(dB)	(dBuV/m)	(dBuV/m)	(dB)	
<b>operation frequency:2462</b>							
V	2483.50	38.06	14.02	52.08	74.00	-21.92	PK
V	2483.50	26.54	14.02	40.56	54.00	-13.44	AV
V	2500.00	38.00	14.06	52.06	74.00	-21.94	PK
V	2500.00	25.96	14.06	40.02	54.00	-13.98	AV
H	2483.50	38.19	14.02	52.21	74.00	-21.79	PK
H	2483.50	26.58	14.02	40.60	54.00	-13.40	AV
H	2500.00	37.80	14.06	51.86	74.00	-22.14	PK
H	2500.00	26.83	14.06	40.89	54.00	-13.11	AV

**Remark:**

1. Emission Level = Meter Reading + Factor, Margin= Emission Level - Limit
2. If peak below the average limit, the average emission was no test.
3. The amplitude of spurious emissions which are attenuated by more than 20dB below the permissible value has no need to be reported.



**802.11n(40MHz)**

Polar (H/V)	Frequency	Meter Reading	Factor	Emission Level	Limits	Margin	Detector Type
	(MHz)	(dBuV)	(dB)	(dBuV/m)	(dBuV/m)	(dB)	
<b>operation frequency:2422</b>							
V	2390.00	38.17	13.83	52.00	74.00	-22.00	PK
V	2390.00	26.51	13.83	40.34	54.00	-13.66	AV
V	2400.00	38.38	13.85	52.23	74.00	-21.77	PK
V	2400.00	26.07	13.85	39.92	54.00	-14.08	AV
H	2390.00	38.46	13.83	52.29	74.00	-21.71	PK
H	2390.00	26.54	13.83	40.37	54.00	-13.63	AV
V	2400.00	38.33	13.85	52.18	74.00	-21.82	PK
V	2400.00	26.48	13.85	40.33	54.00	-13.67	AV

Polar (H/V)	Frequency	Meter Reading	Factor	Emission Level	Limits	Margin	Detector Type
	(MHz)	(dBuV)	(dB)	(dBuV/m)	(dBuV/m)	(dB)	
<b>operation frequency:2452</b>							
V	2483.50	38.38	14.02	52.40	74.00	-21.60	PK
V	2483.50	26.76	14.02	40.78	54.00	-13.22	AV
V	2500.00	38.32	14.06	52.38	74.00	-21.62	PK
V	2500.00	26.18	14.06	40.24	54.00	-13.76	AV
H	2483.50	38.50	14.02	52.52	74.00	-21.48	PK
H	2483.50	26.80	14.02	40.82	54.00	-13.18	AV
H	2500.00	38.12	14.06	52.18	74.00	-21.82	PK
H	2500.00	27.06	14.06	41.12	54.00	-12.88	AV

**Remark:**

1. Emission Level = Meter Reading + Factor, Margin= Emission Level - Limit
2. If peak below the average limit, the average emission was no test.
3. The amplitude of spurious emissions which are attenuated by more than 20dB below the permissible value has no need to be reported.



## 4. POWER SPECTRAL DENSITY TEST

### 4.1 APPLIED PROCEDURES / LIMIT

FCC Part15 (15.247) , Subpart C				
Section	Test Item	Limit	Frequency Range (MHz)	Result
15.247	Power Spectral Density	8 dBm (in any 3KHz)	2400-2483.5	PASS

#### 4.1.1 TEST PROCEDURE

1. Set analyzer center frequency to DTS channel center frequency.
2. Set the span to 1.5 times the DTS bandwidth.
3. Set the RBW to:  $3 \text{ kHz} \leq \text{RBW} \leq 100 \text{ kHz}$ .
4. Set the VBW  $\geq 3 \times \text{RBW}$ .
5. Detector = peak.
6. Sweep time = auto couple.
7. Trace mode = max hold.
8. Allow trace to fully stabilize.
9. Use the peak marker function to determine the maximum amplitude level within the RBW.
10. If measured value exceeds limit, reduce RBW (no less than 3 kHz) and repeat.

#### 4.1.2 DEVIATION FROM STANDARD

No deviation.

#### 4.1.3 TEST SETUP

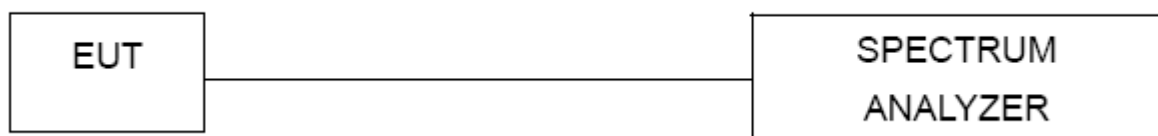

#### 4.1.4 EUT OPERATION CONDITIONS

The EUT tested system was configured as the statements of 2.1 Unless otherwise a special operating condition is specified in the follows during the testing.



**4.1.5 TEST RESULTS**

Temperature :	25°C	Relative Humidity :	60%
Pressure :	1015 hPa	Test Voltage :	DC 12V from adapter
Test Mode :	TX b Mode		

Frequency	Read Level (dBm)		Total Power Spectral Density(dBm)	Limit (dBm)	Result
	Ant.1	Ant.2			
2412 MHz	Ant.1	-3.24	-0.61	8	PASS
	Ant.2	-3.93			
2437 MHz	Ant.1	-2.18	0.04	8	PASS
	Ant.2	-3.96			
2462 MHz	Ant.1	-1.83	0.79	8	PASS
	Ant.2	-2.70			

Ant. 1

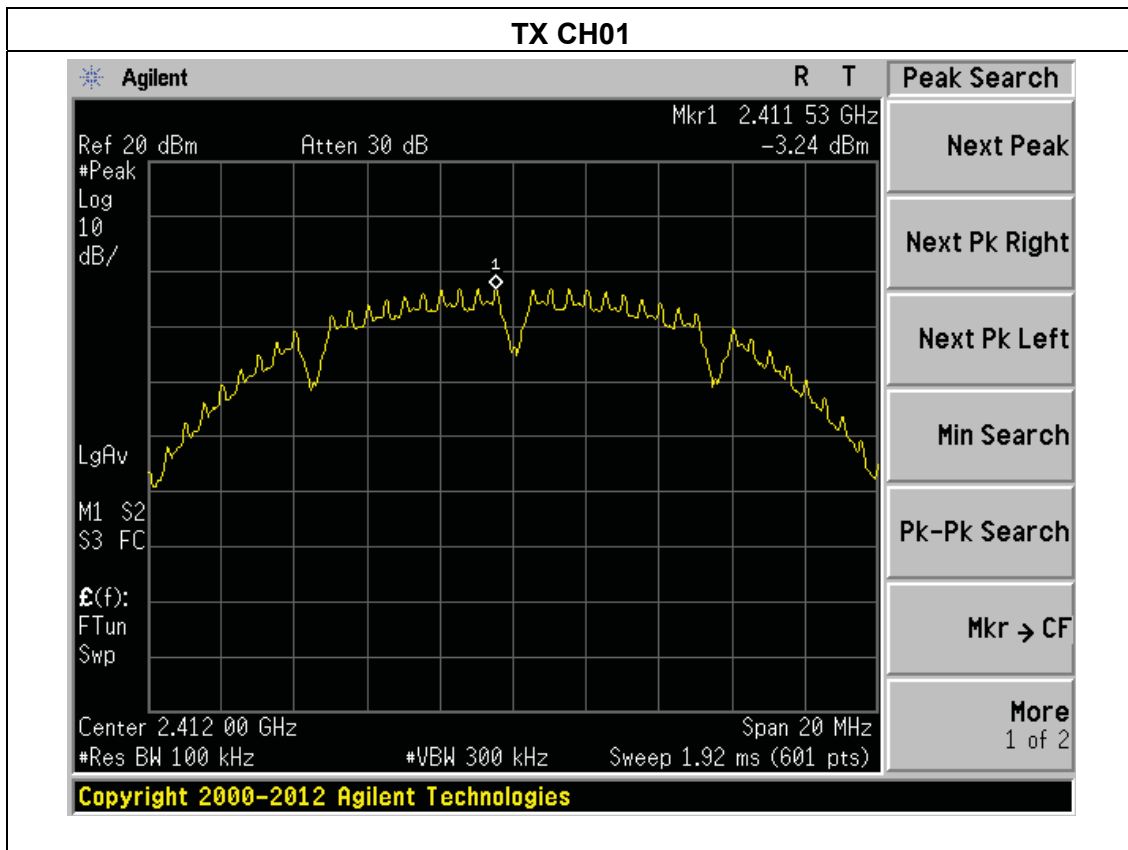



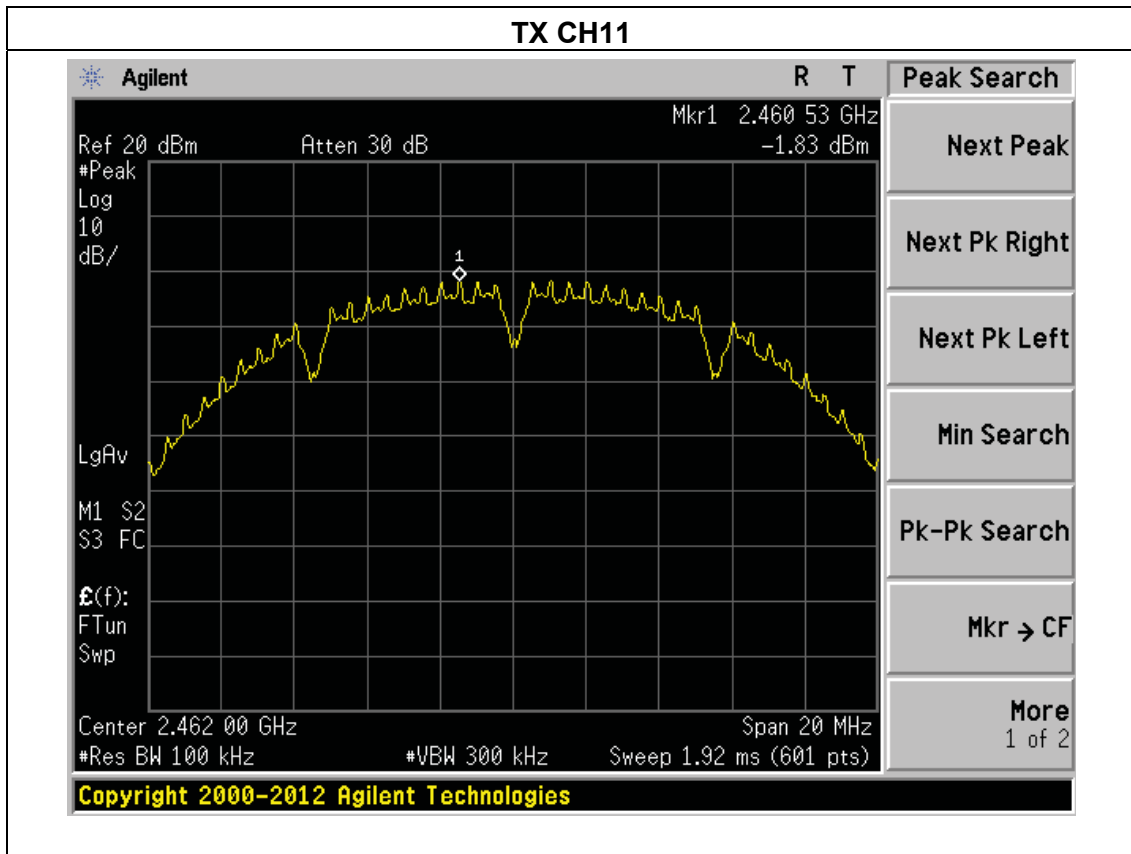
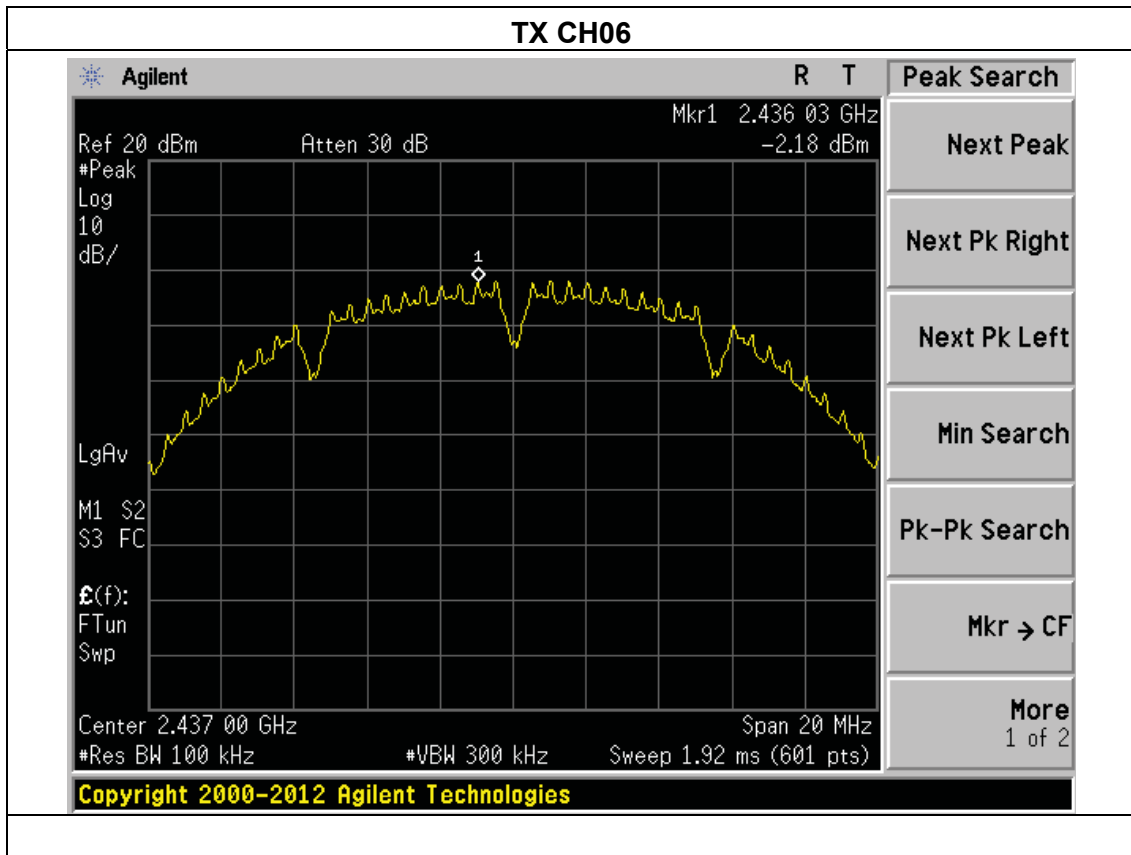



Ant. 2

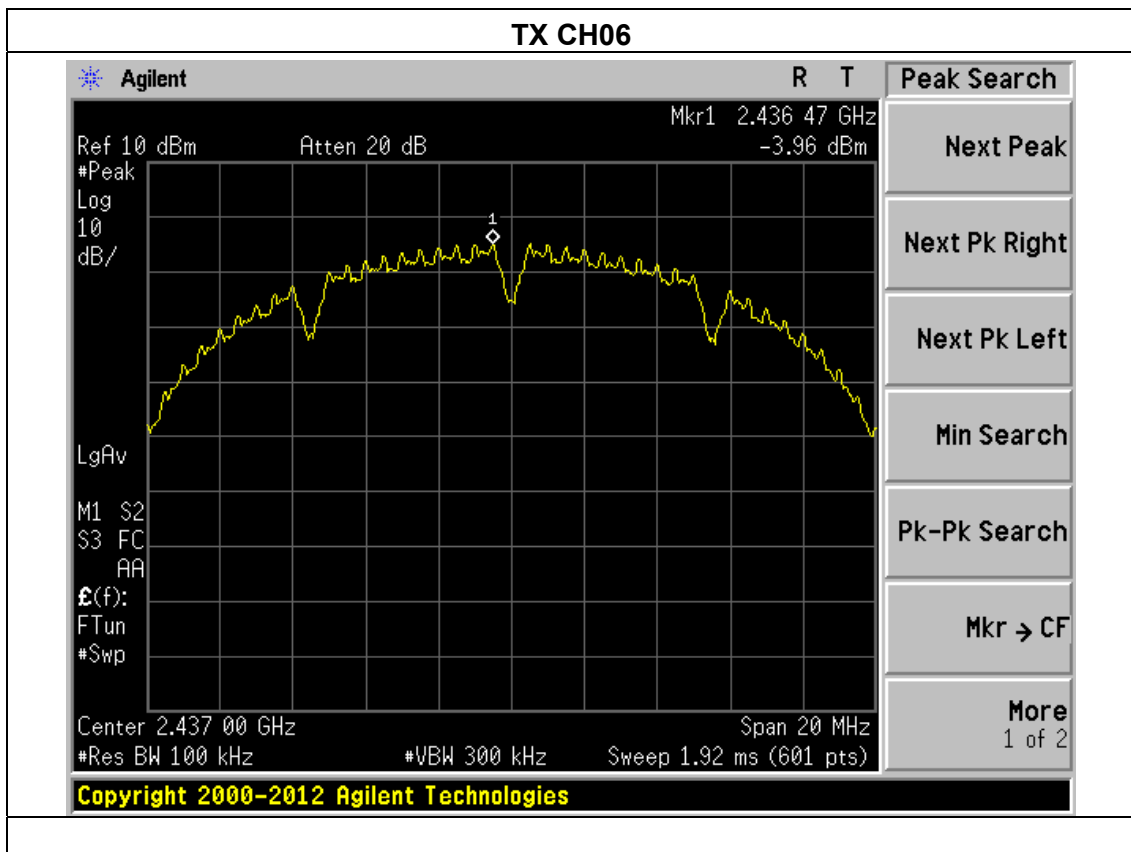
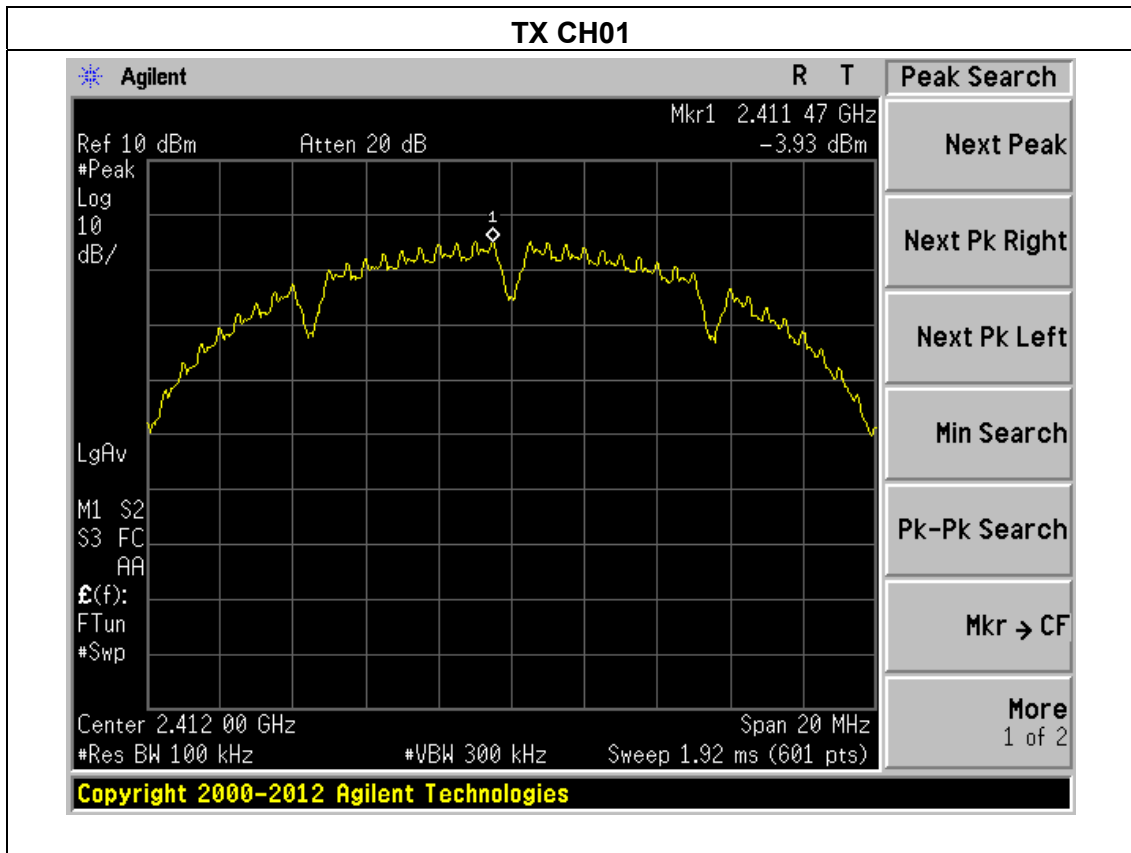

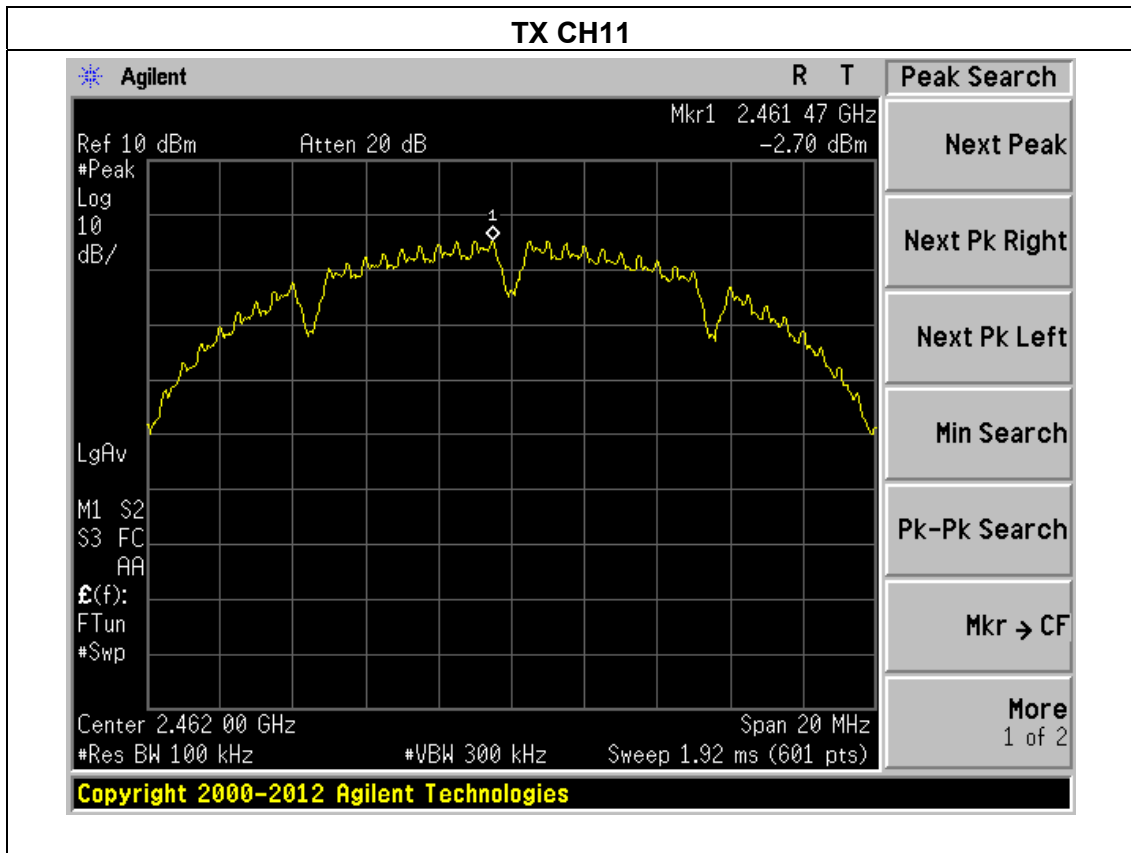



Temperature :	25°C	Relative Humidity :	60%
Pressure :	1015 hPa	Test Voltage :	DC 12V from adapter
Test Mode :	TX g Mode		

Frequency	Read Level (dBm)		Total Power Spectral Density(dBm)	Limit (dBm)	Result
	Ant.1	Ant.2			
2412 MHz	Ant.1	-6.39	-3.10	8	PASS
	Ant.2	-5.85			
2437 MHz	Ant.1	-4.70	-1.37	8	PASS
	Ant.2	-4.11			
2462 MHz	Ant.1	-4.70	-1.87	8	PASS
	Ant.2	-5.14			

Ant.1

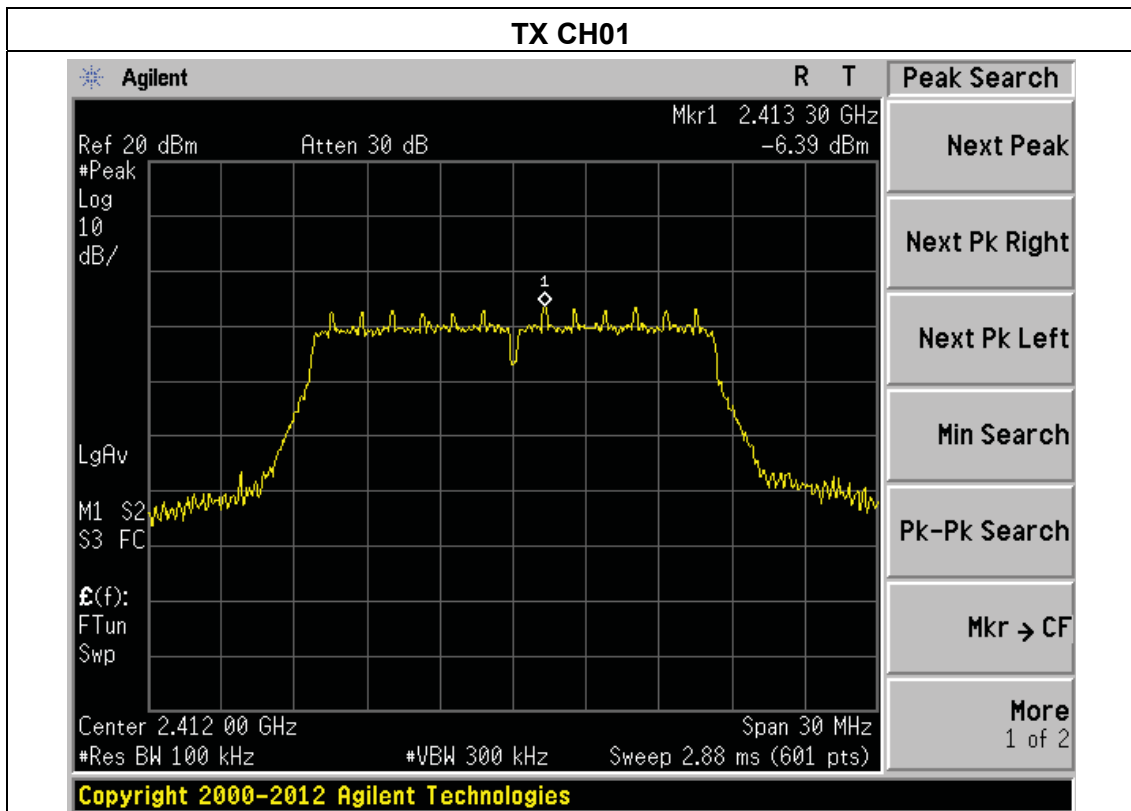

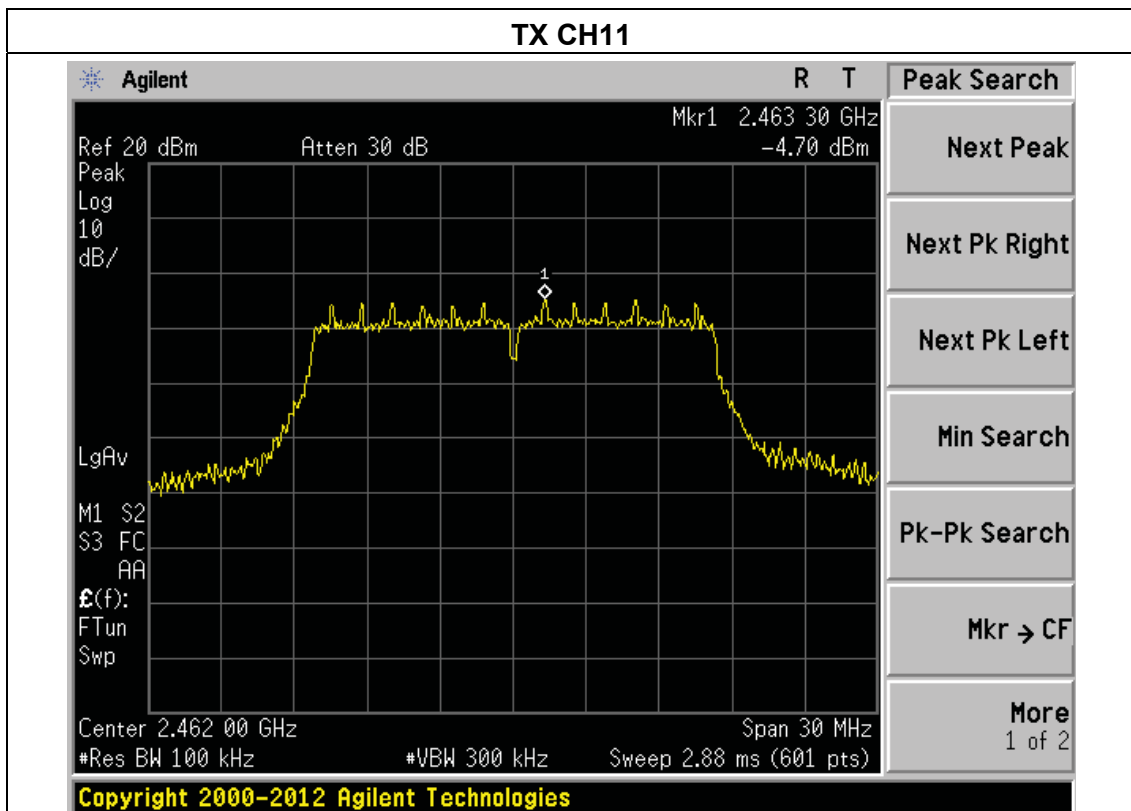
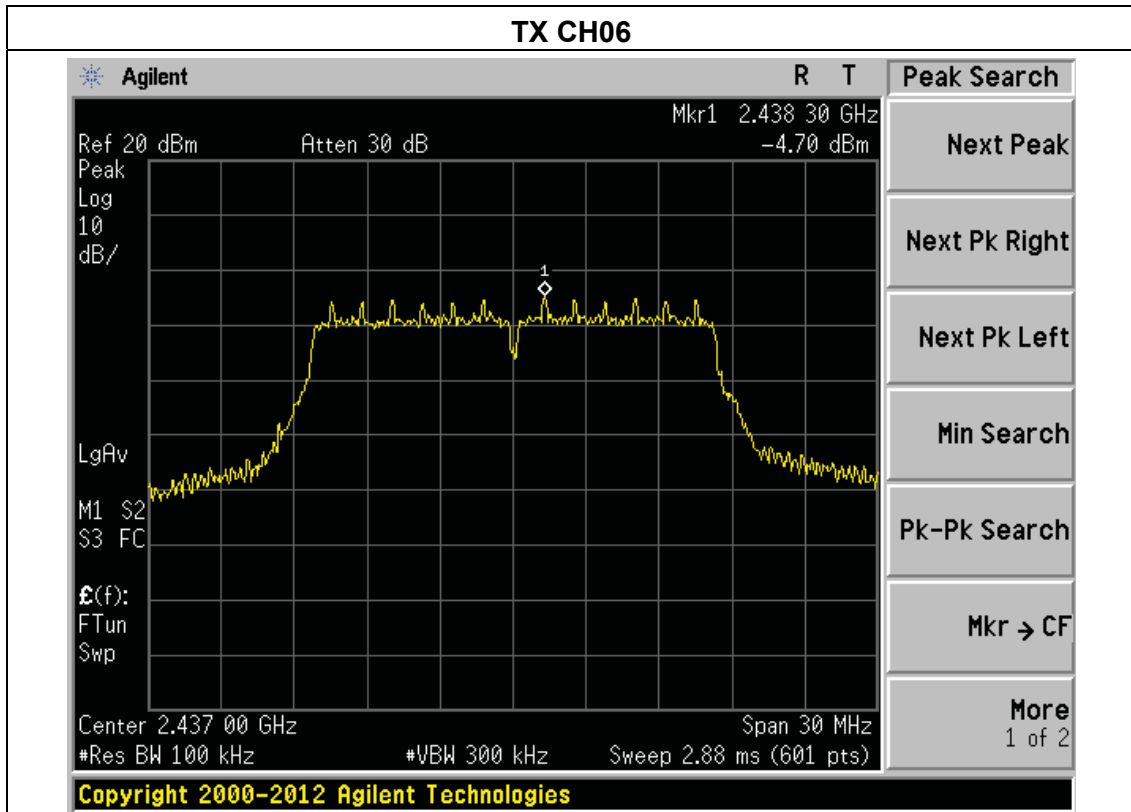



Ant.2

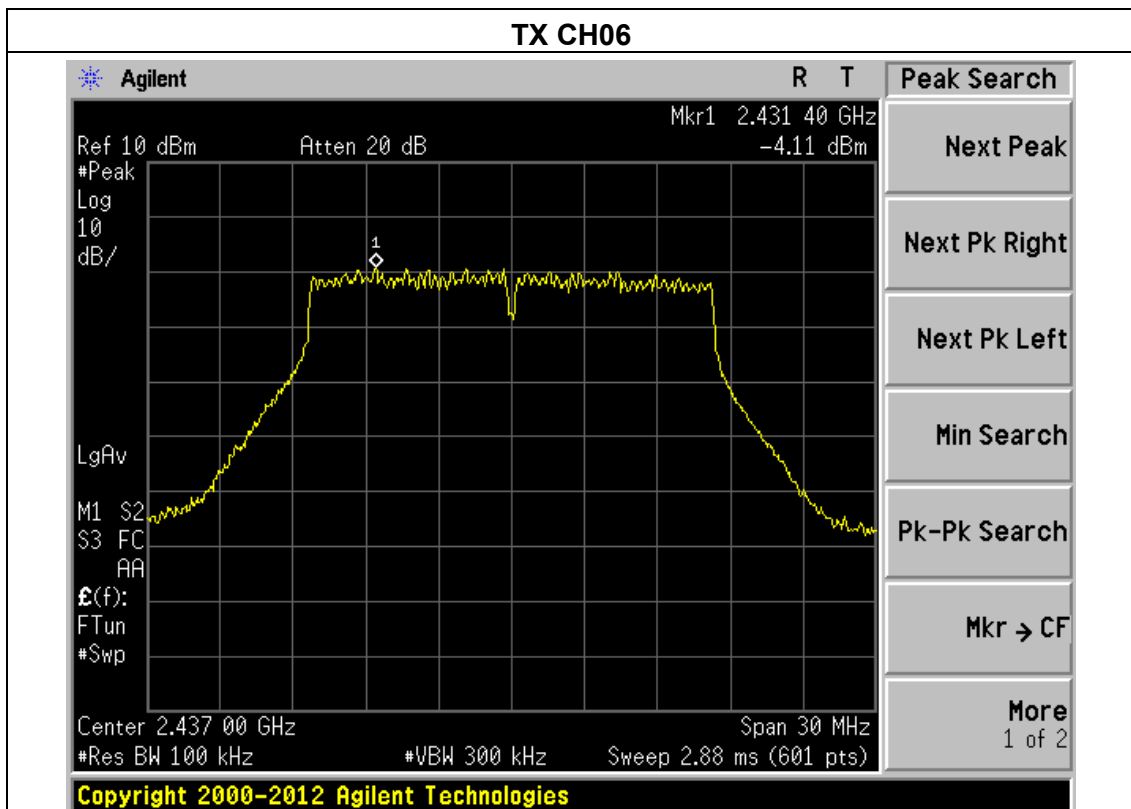
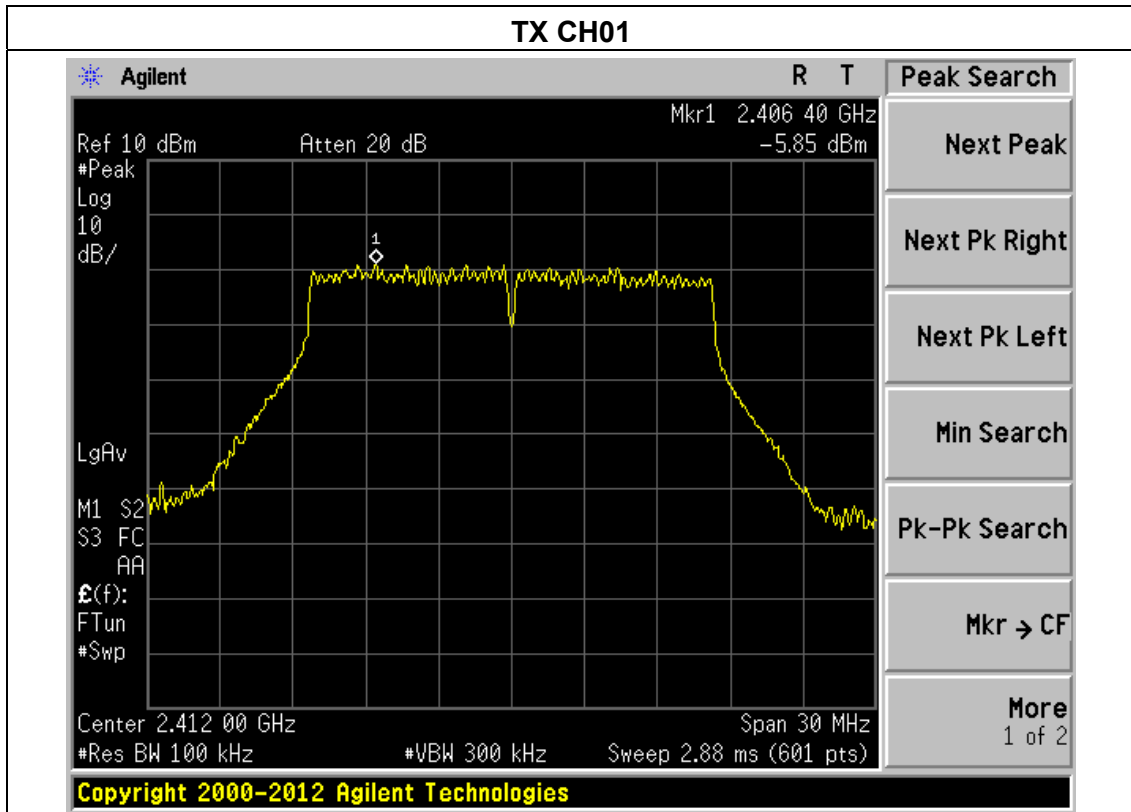

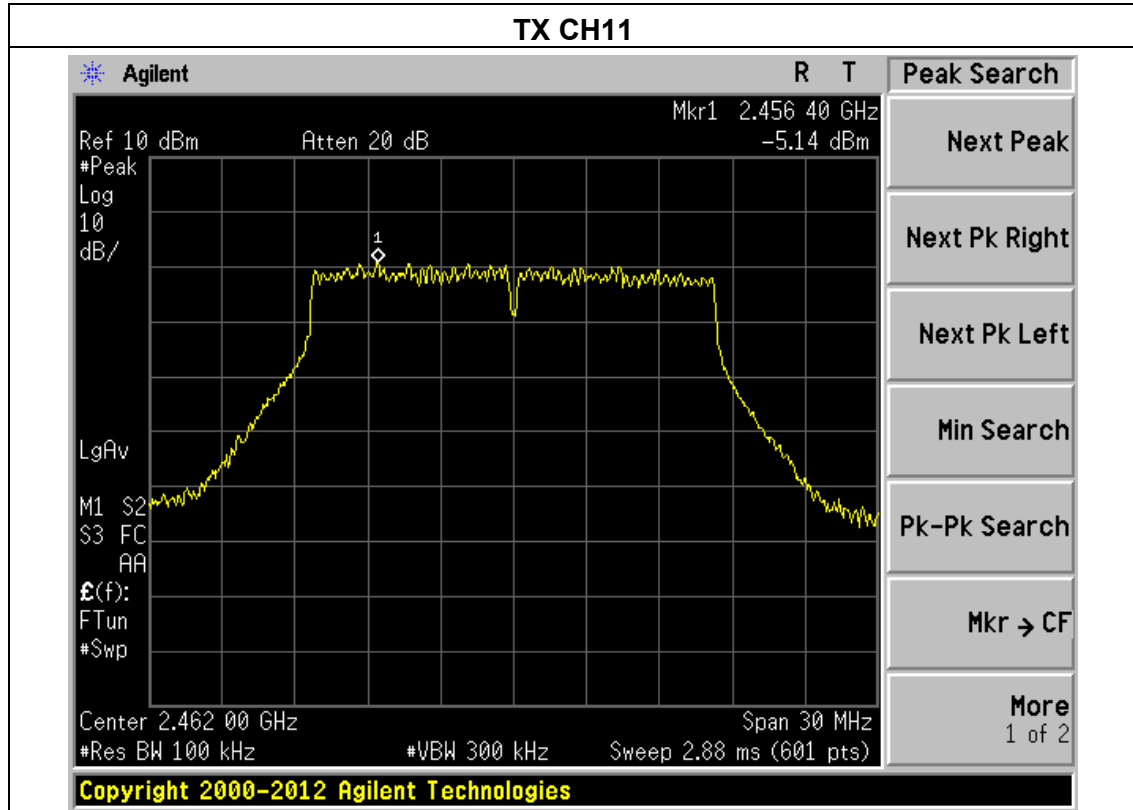



Temperature :	25°C	Relative Humidity :	60%
Pressure :	1015 hPa	Test Voltage :	DC 12V from adapter
Test Mode :	TX n Mode(20M)		

Frequency	Read Level (dBm)		Total Power Spectral Density(dBm)	Limit (dBm)	Result
	Ant.1	Ant.2			
2412 MHz	Ant.1	-4.07	-3.28	8	PASS
	Ant.2	-10.76			
2437 MHz	Ant.1	-6.53	-4.77	8	PASS
	Ant.2	-11.19			
2462 MHz	Ant.1	-4.87	-3.87	8	PASS
	Ant.2	-11.15			

Ant.1

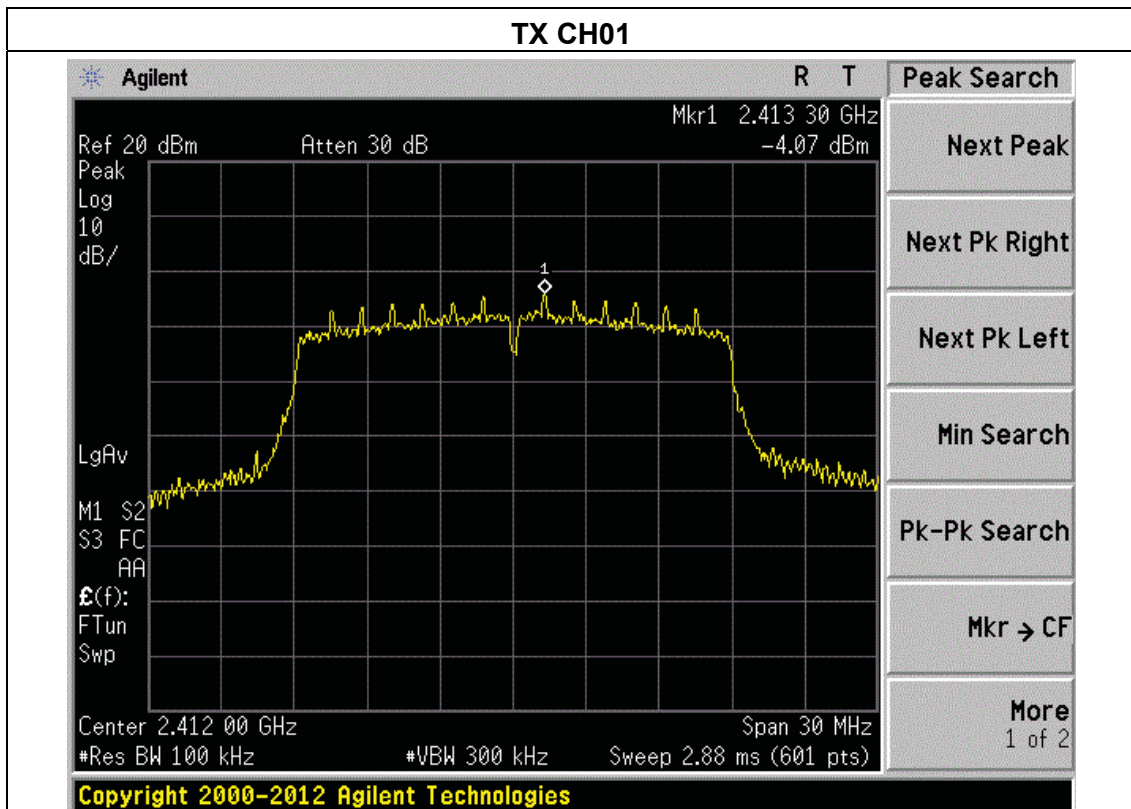



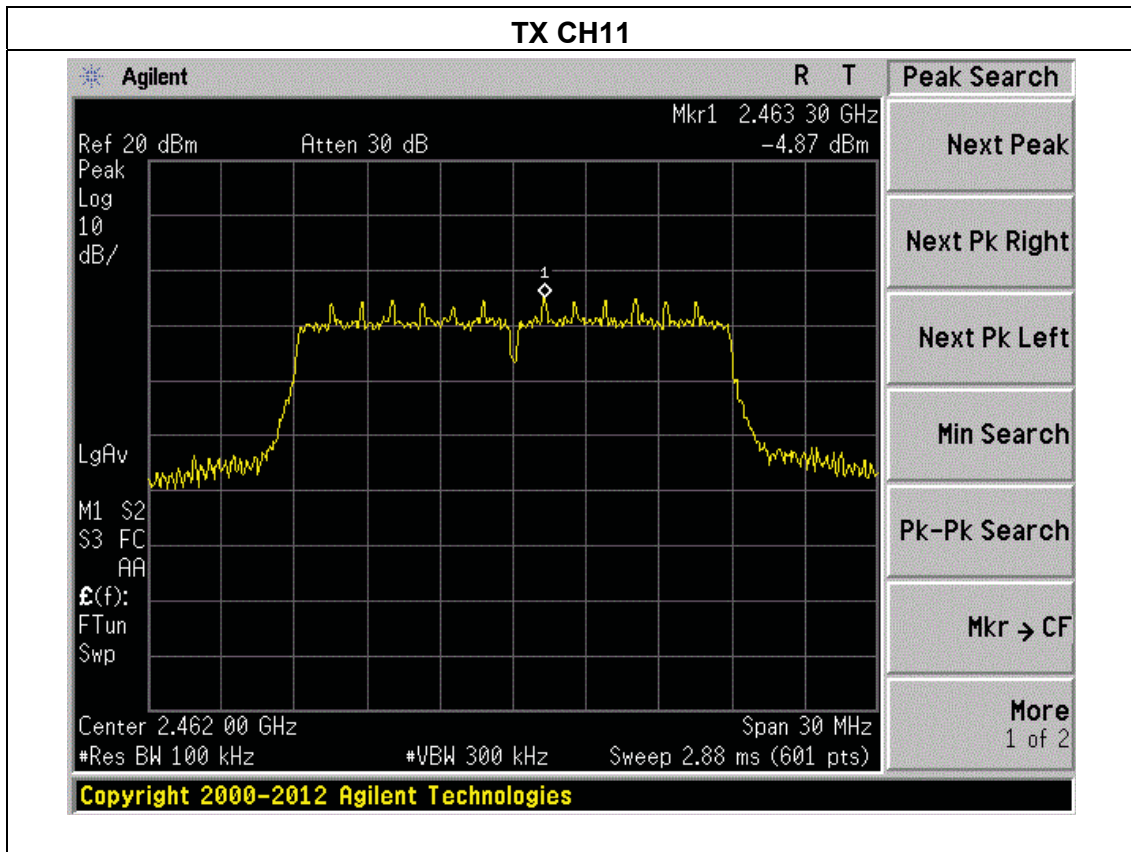
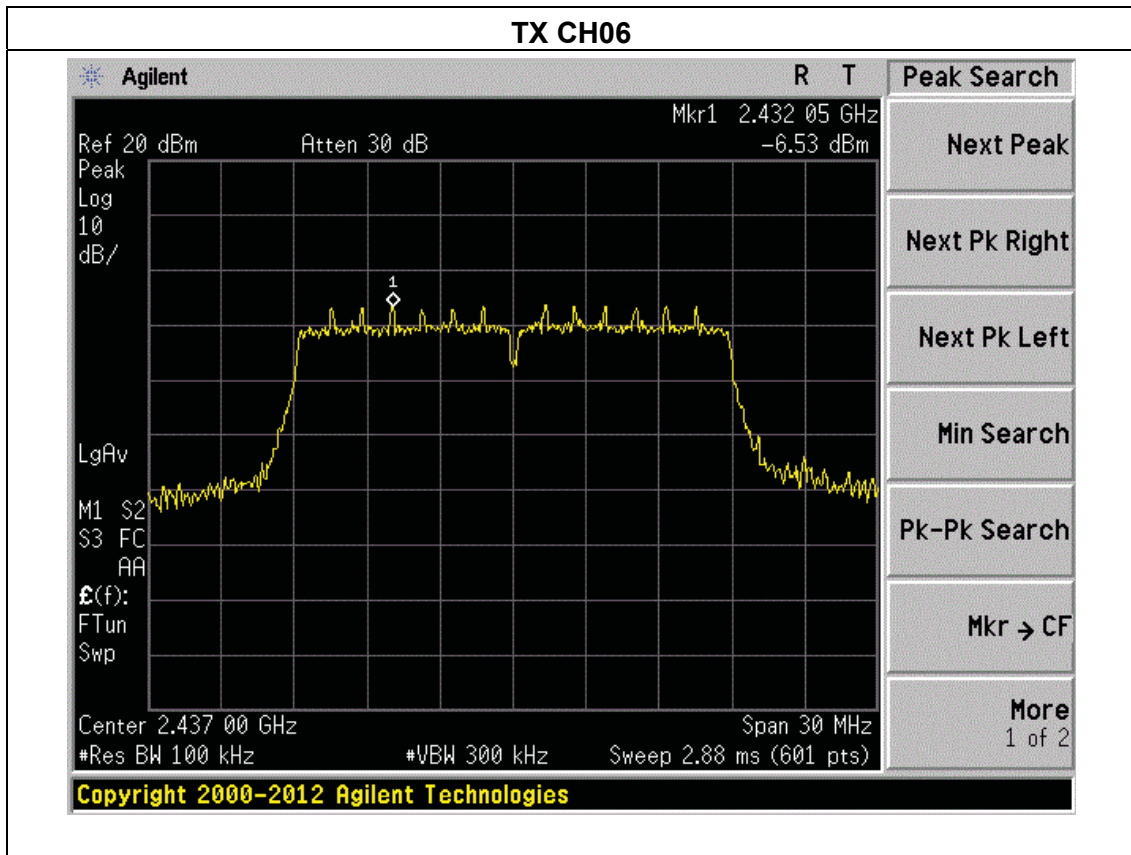



Ant.2

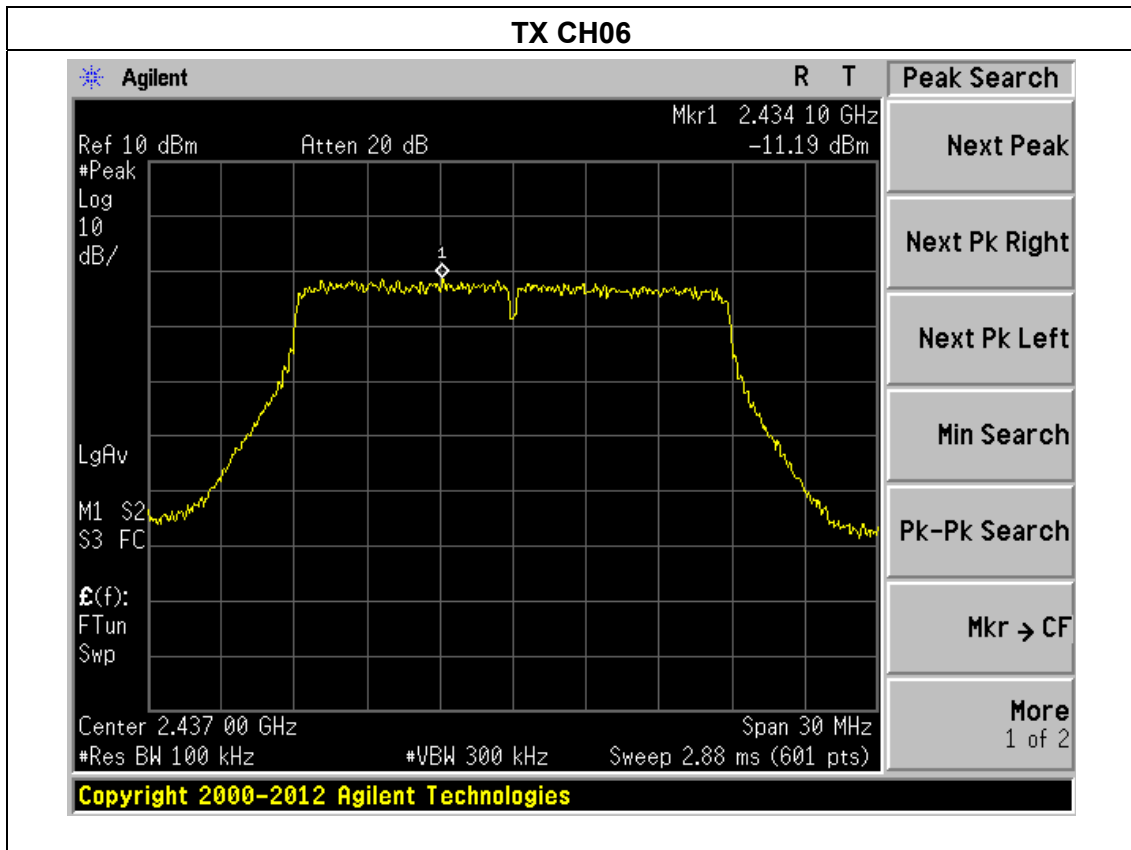
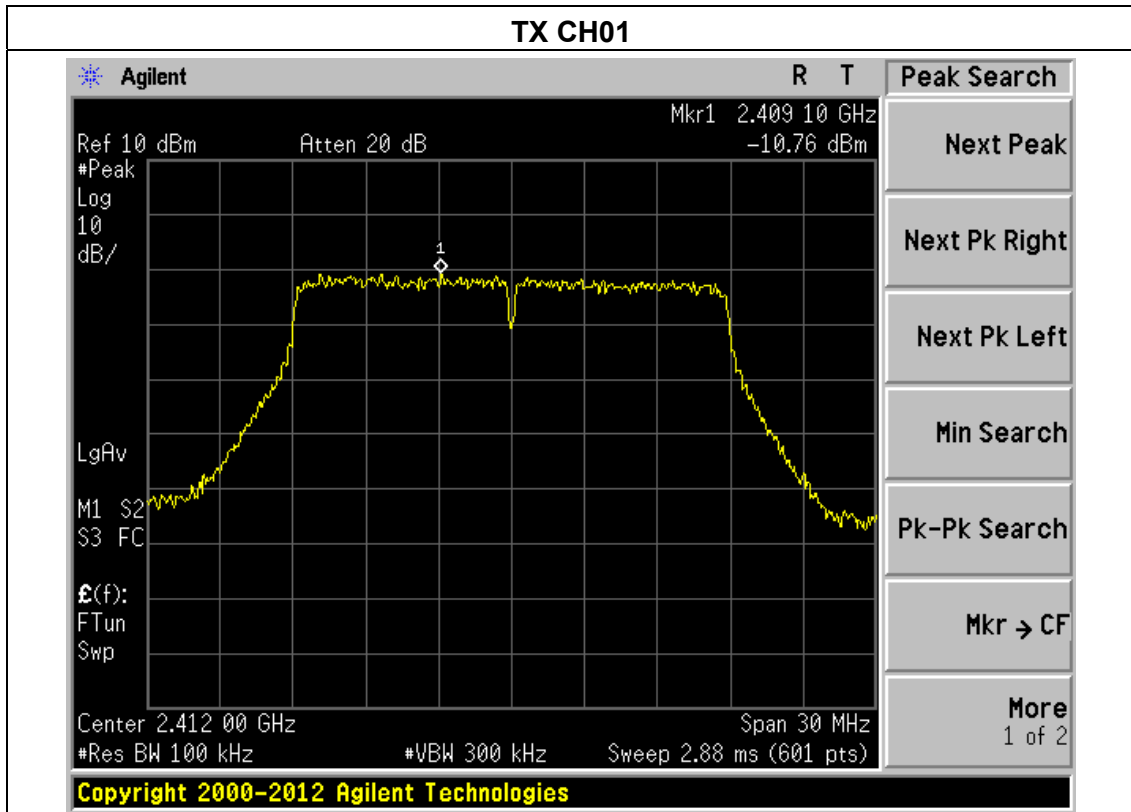

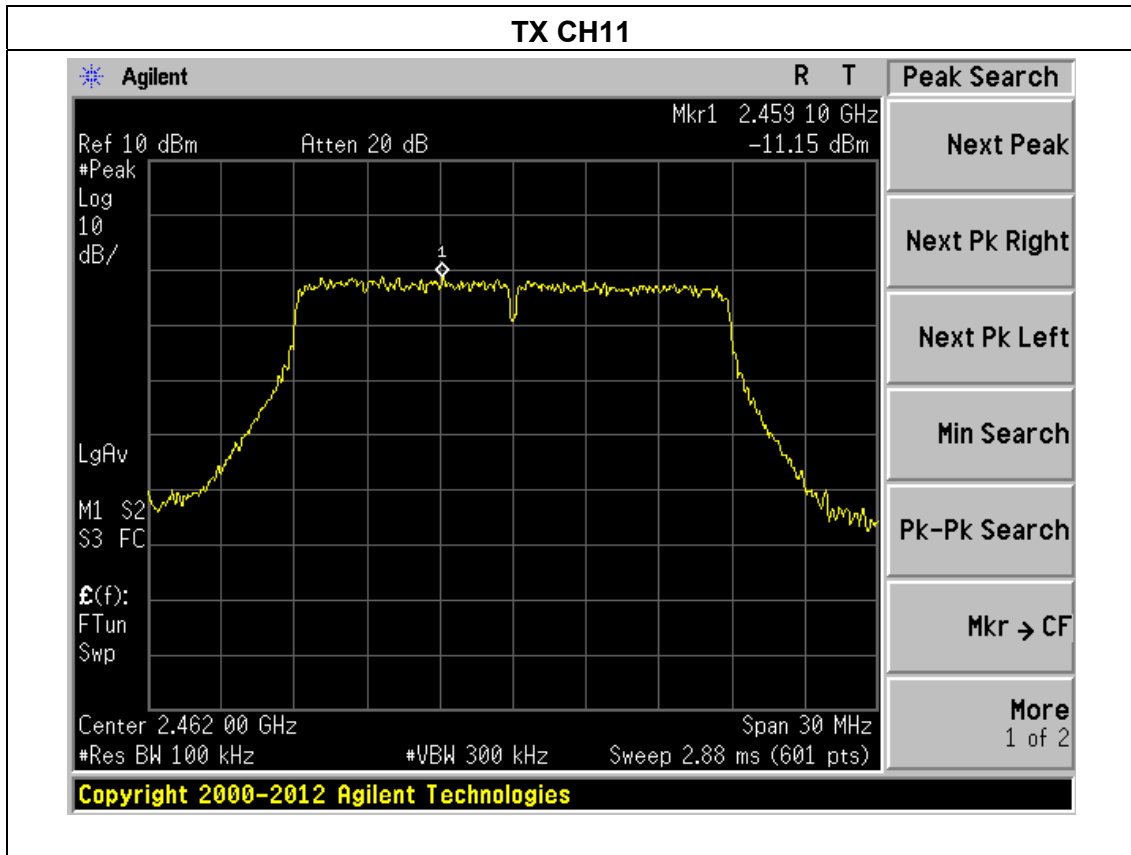



Temperature :	25°C	Relative Humidity :	60%
Pressure :	1015 hPa	Test Voltage :	DC 12V from adapter
Test Mode :	TX n Mode(40M)		

Frequency	Read Level (dBm)		Total Power Spectral Density(dBm)	Limit (dBm)	Result
	Ant.1	Ant.2			
2422 MHz	Ant.1	-9.29	-7.21	8	PASS
	Ant.2	-11.39			
2437 MHz	Ant.1	-8.43	-6.78	8	PASS
	Ant.2	-11.56			
2452 MHz	Ant.1	-7.83	-6.38	8	PASS
	Ant.2	-11.71			

Ant.1

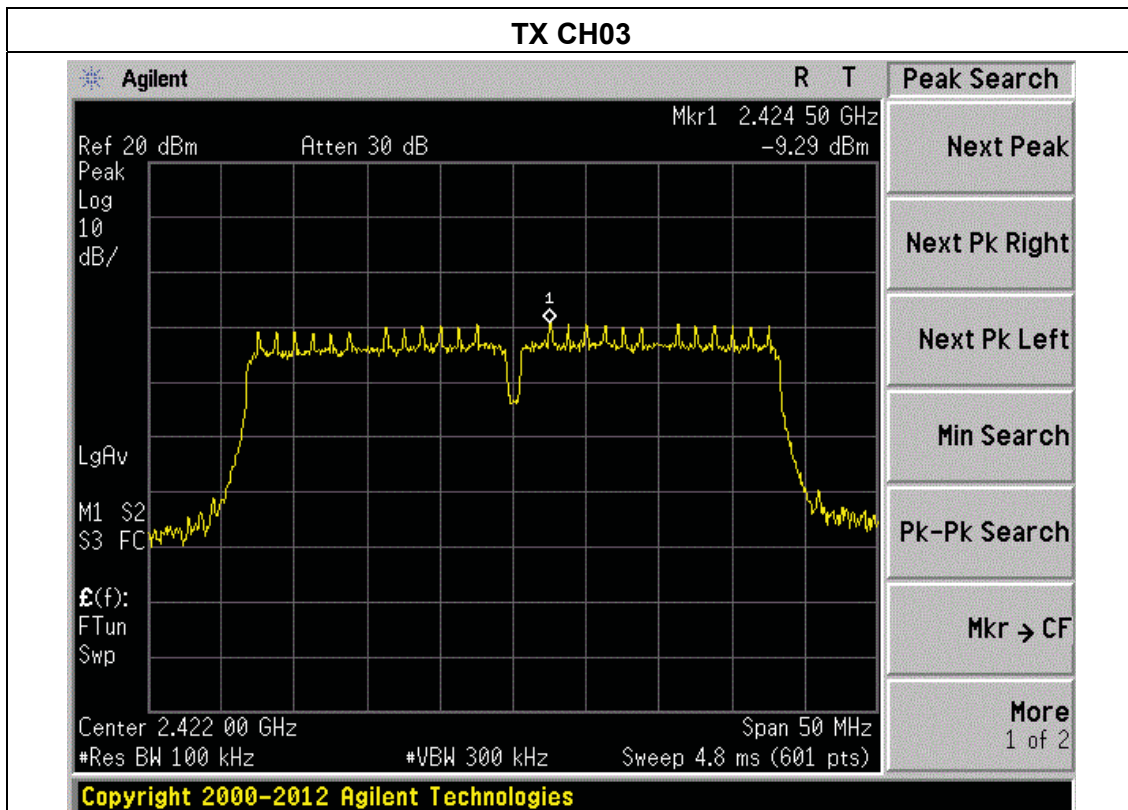

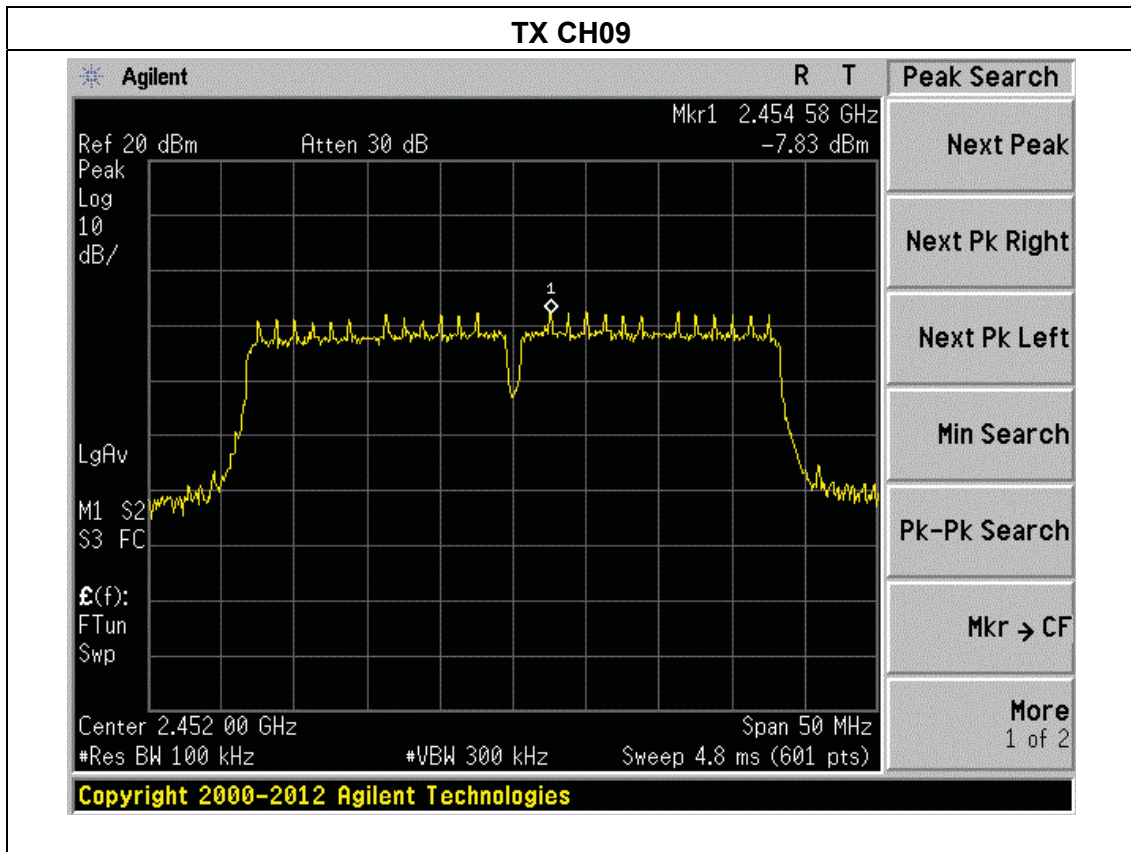
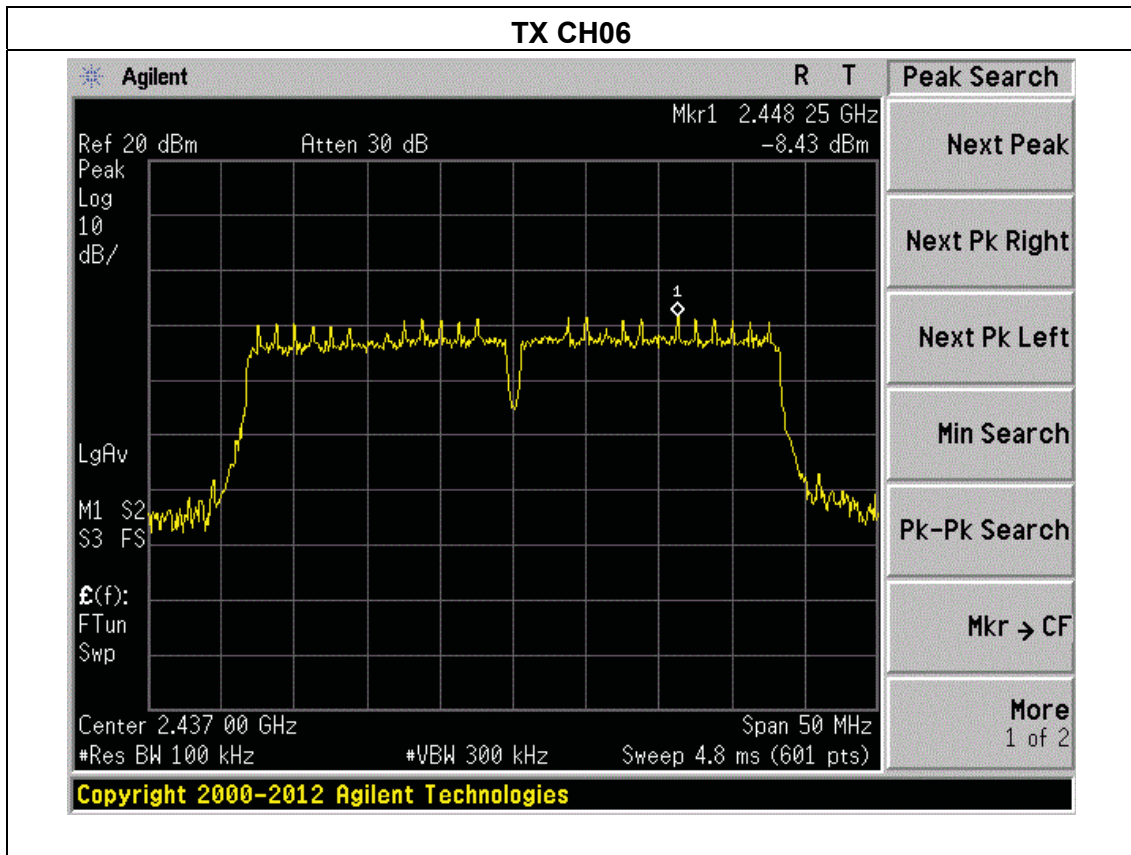



Ant.2

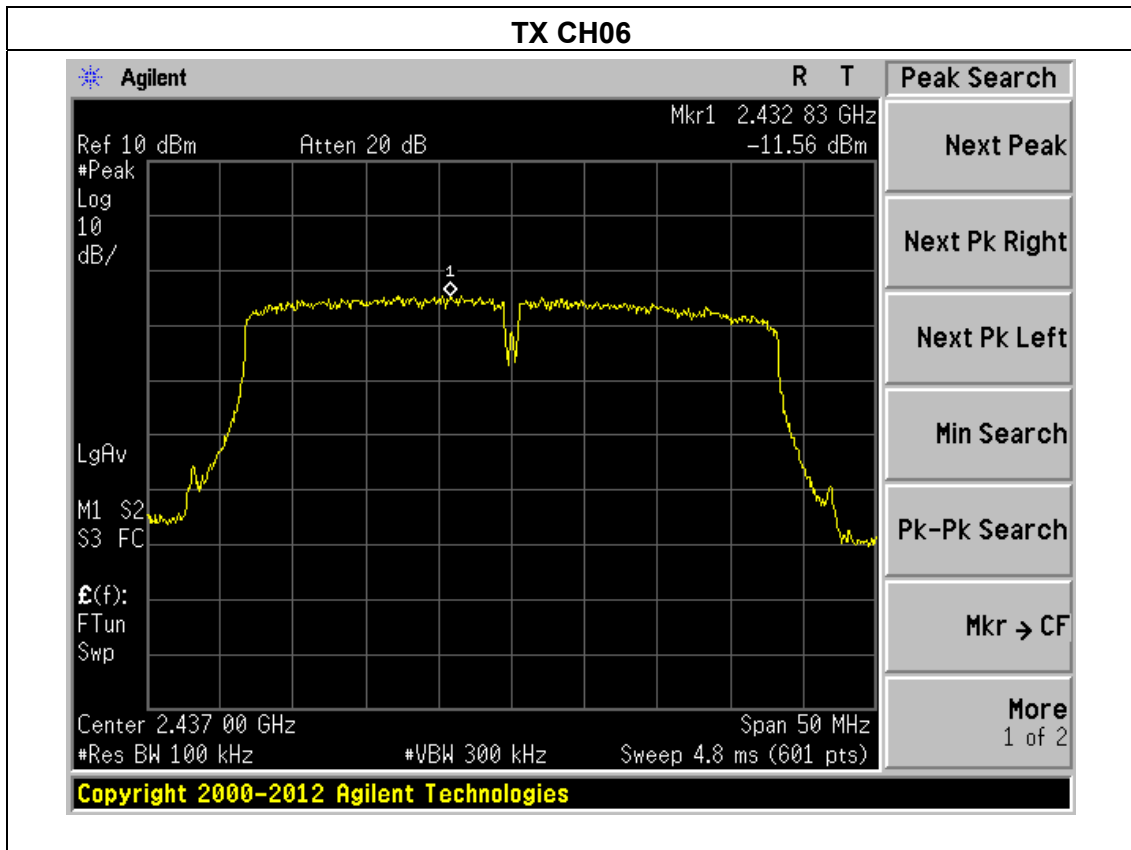
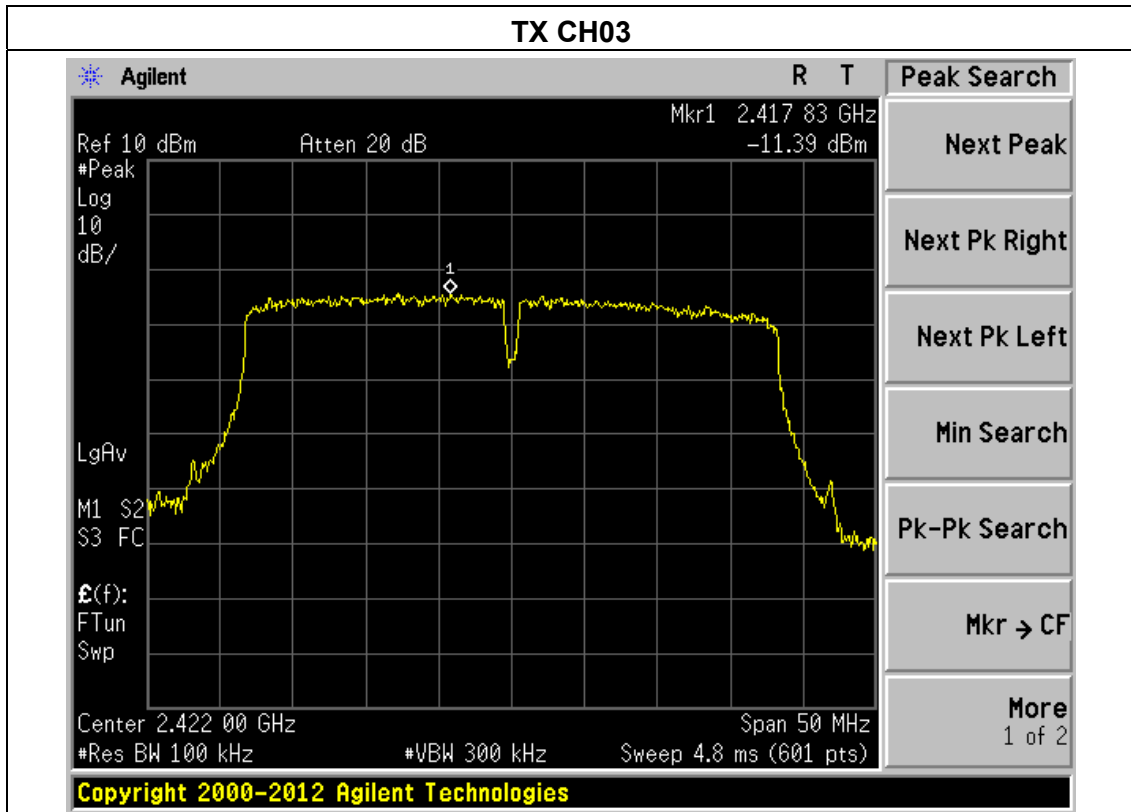

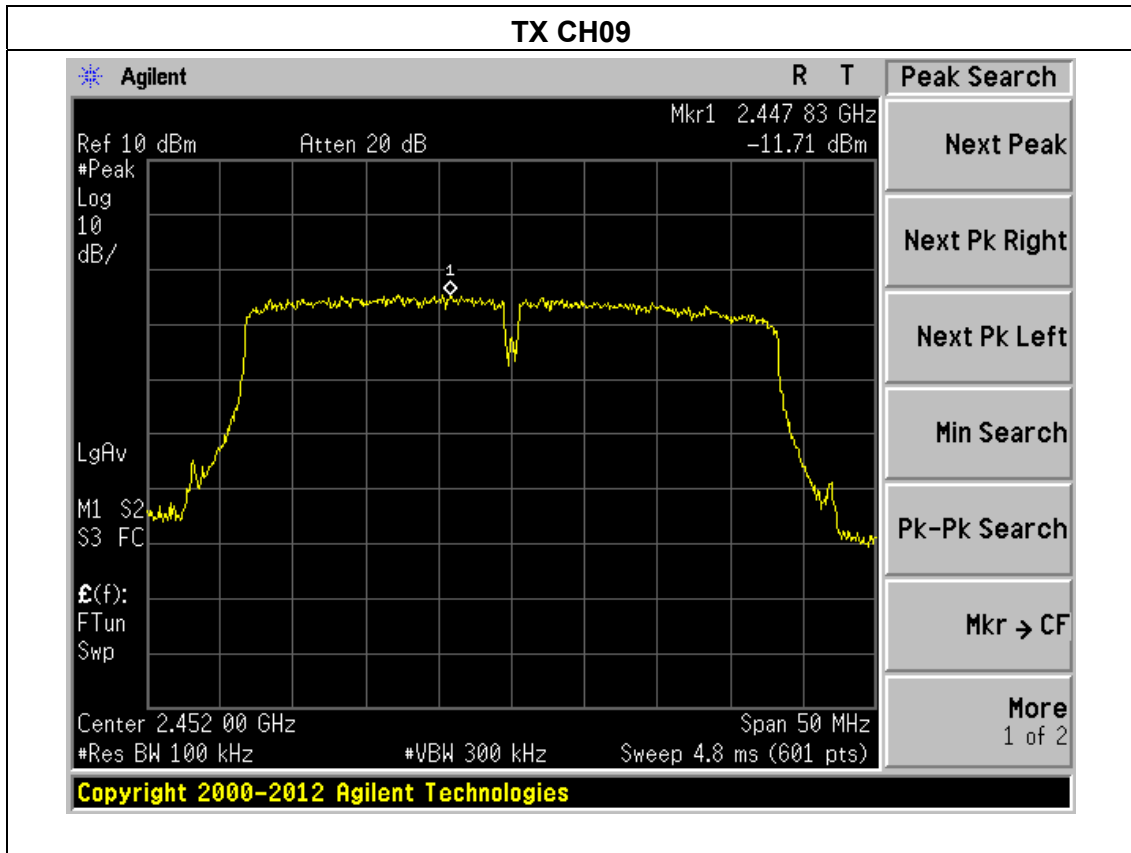





## 5. BANDWIDTH TEST

### 5.1 APPLIED PROCEDURES / LIMIT

FCC Part15 (15.247) , Subpart C				
Section	Test Item	Limit	Frequency Range (MHz)	Result
15.247(a)(2)	Bandwidth	$\geq 500\text{KHz}$ (6dB bandwidth)	2400-2483.5	PASS

#### 5.1.1 TEST PROCEDURE

1. Set RBW = 100 kHz.
2. Set the video bandwidth (VBW)  $\geq 3 \times$  RBW.
3. Detector = Peak.
4. Trace mode = max hold.
5. Sweep = auto couple.
6. Allow the trace to stabilize.
7. Measure the maximum width of the emission that is constrained by the frequencies associated with the two outermost amplitude points (upper and lower frequencies) that are attenuated by 6 dB relative to the maximum level measured in the fundamental emission.

#### 5.1.2 DEVIATION FROM STANDARD

No deviation.

#### 5.1.3 TEST SETUP



#### 5.1.4 EUT OPERATION CONDITIONS

The EUT tested system was configured as the statements of 2.4 Unless otherwise a special operating condition is specified in the follows during the testing.





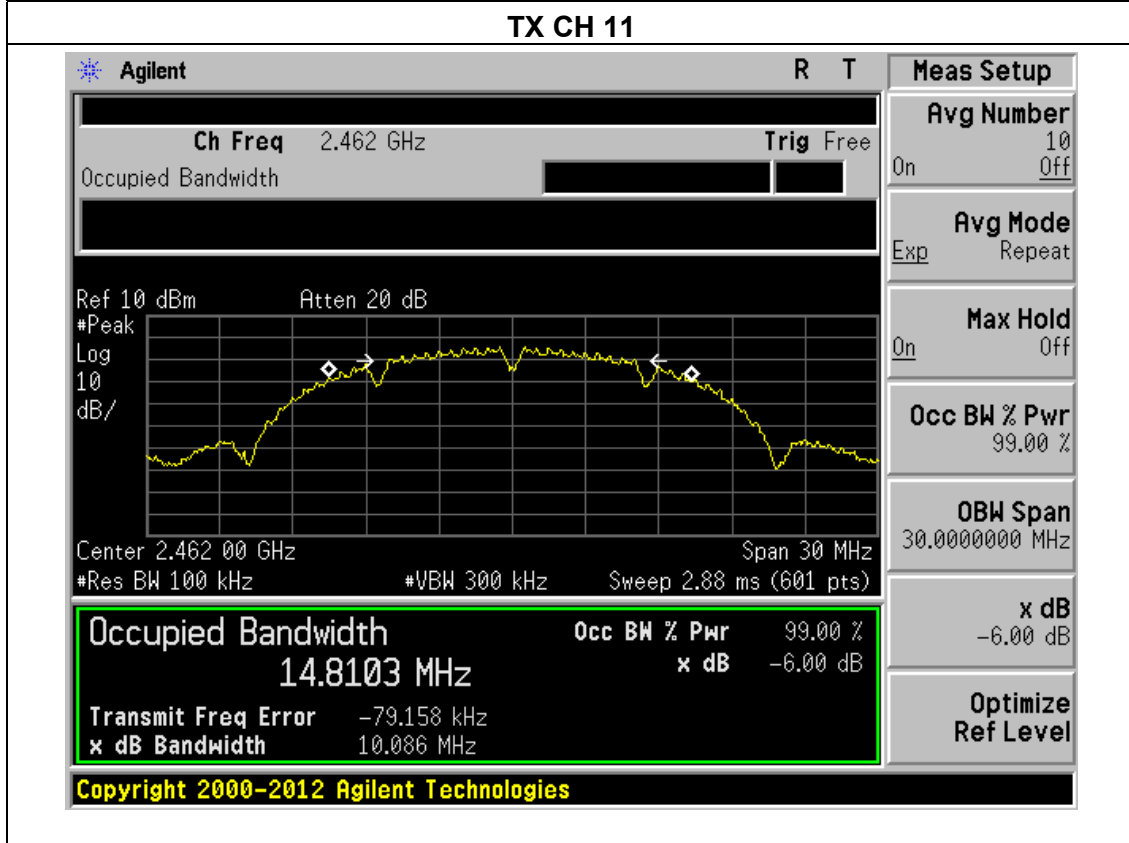
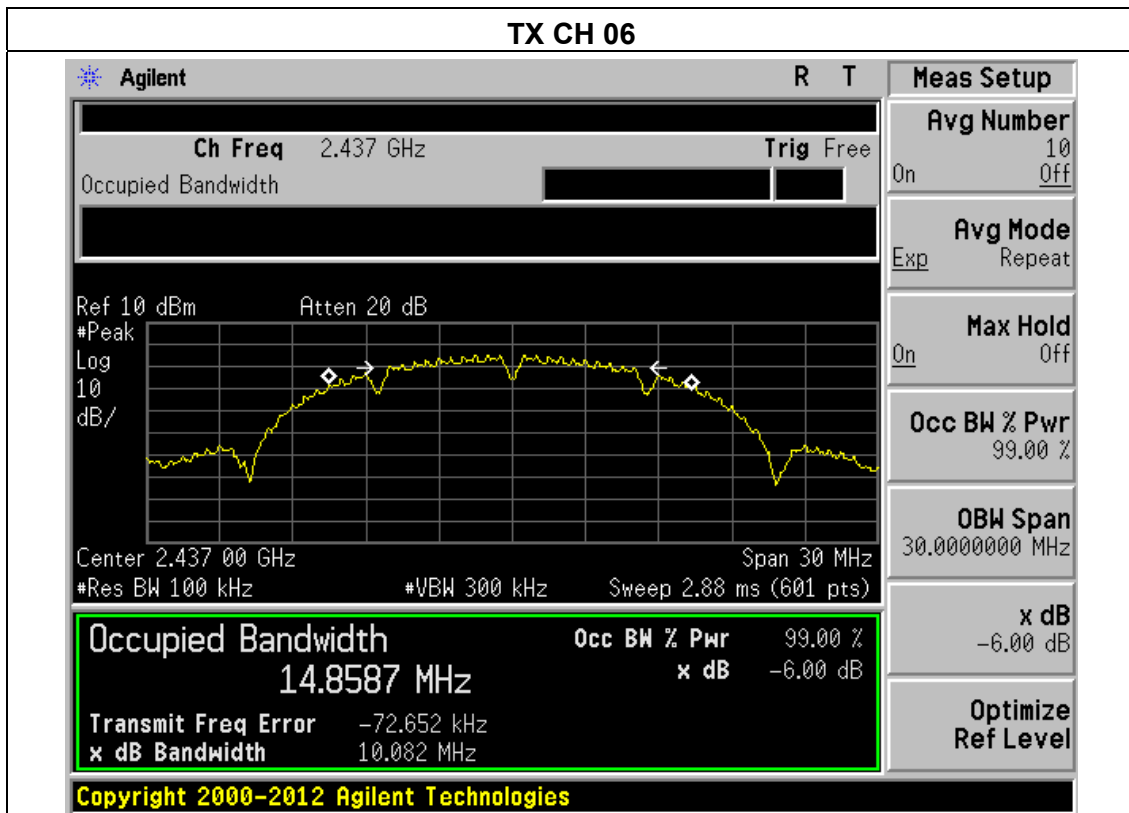



Ant.2

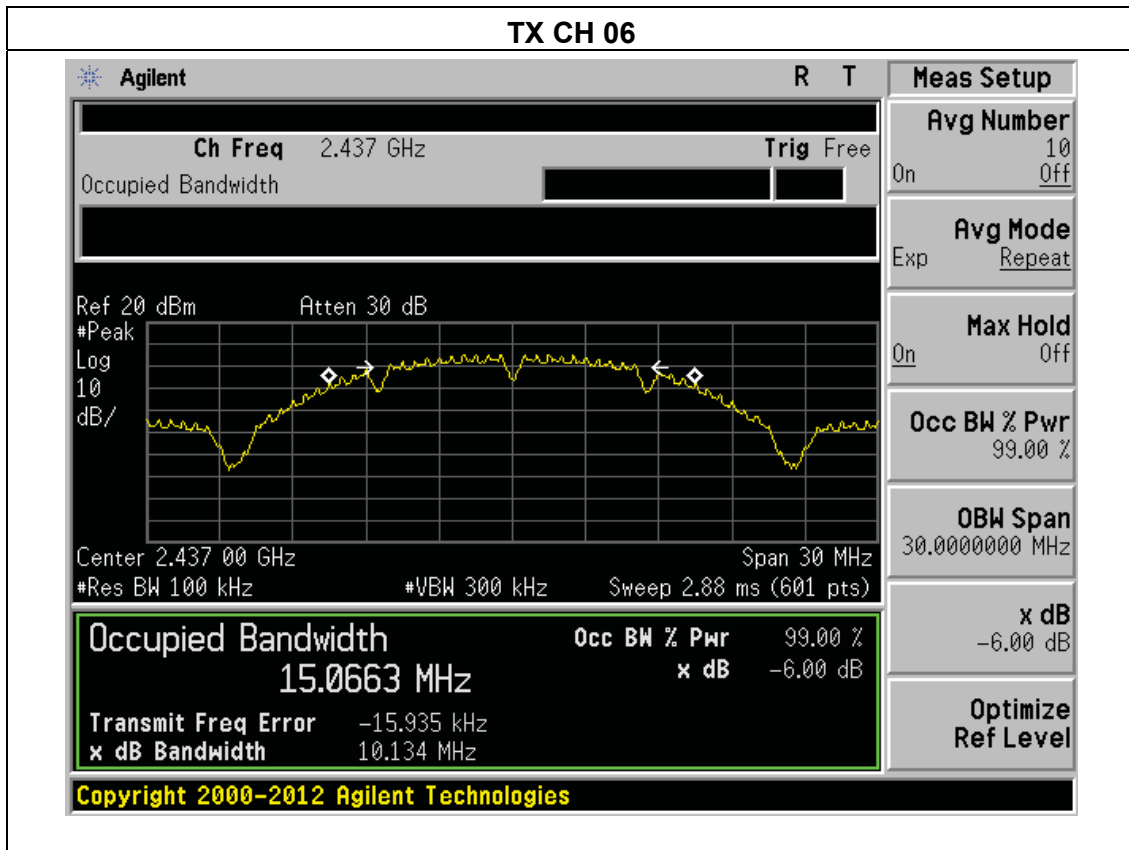
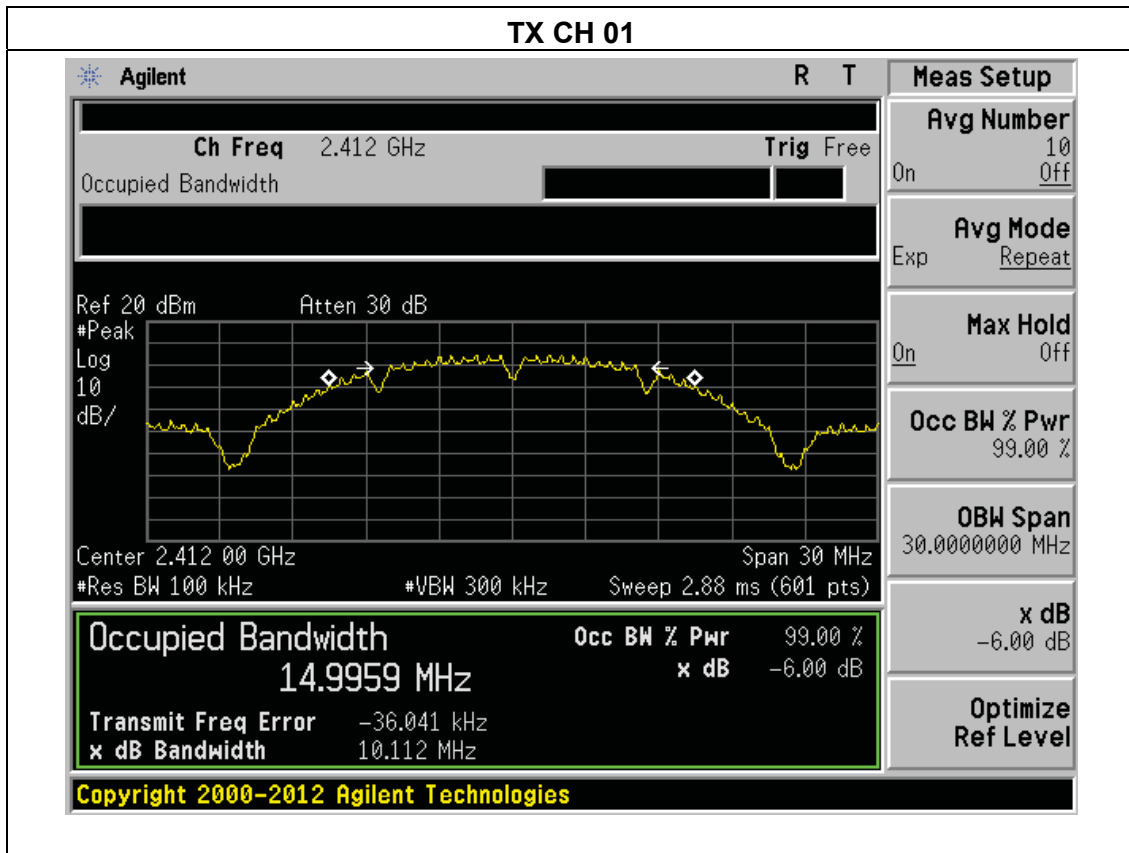

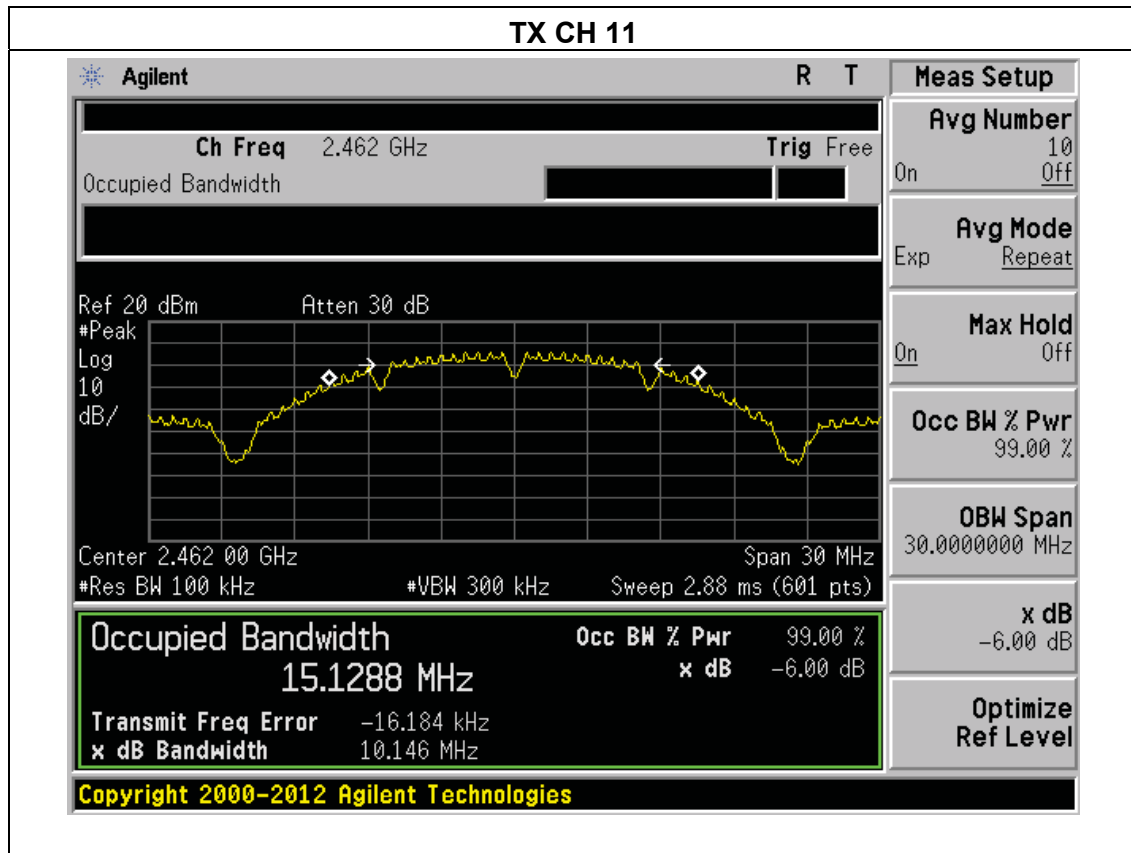



Temperature :	25°C	Relative Humidity :	60%
Pressure :	1012 hPa	Test Voltage :	DC 12V from adapter
Test Mode :	TX g Mode		

Channel	Frequency (MHz)	6dB bandwidth (MHz)		Limit (kHz)	Result
Low	2412	Ant.1	16.579	500	Pass
		Ant.2	16.438	500	Pass
Middle	2437	Ant.1	16.551	500	Pass
		Ant.2	15.142	500	Pass
High	2462	Ant.1	16.574	500	Pass
		Ant.2	15.155	500	Pass

Ant.1

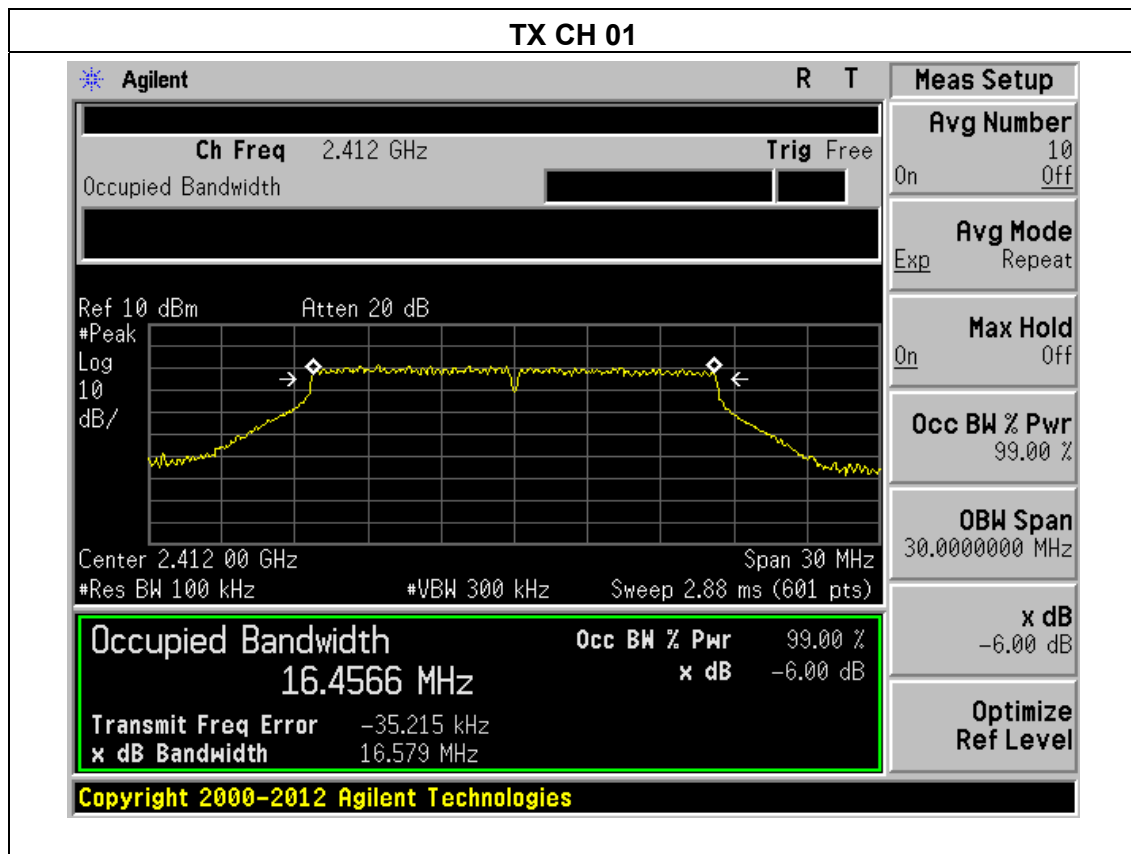

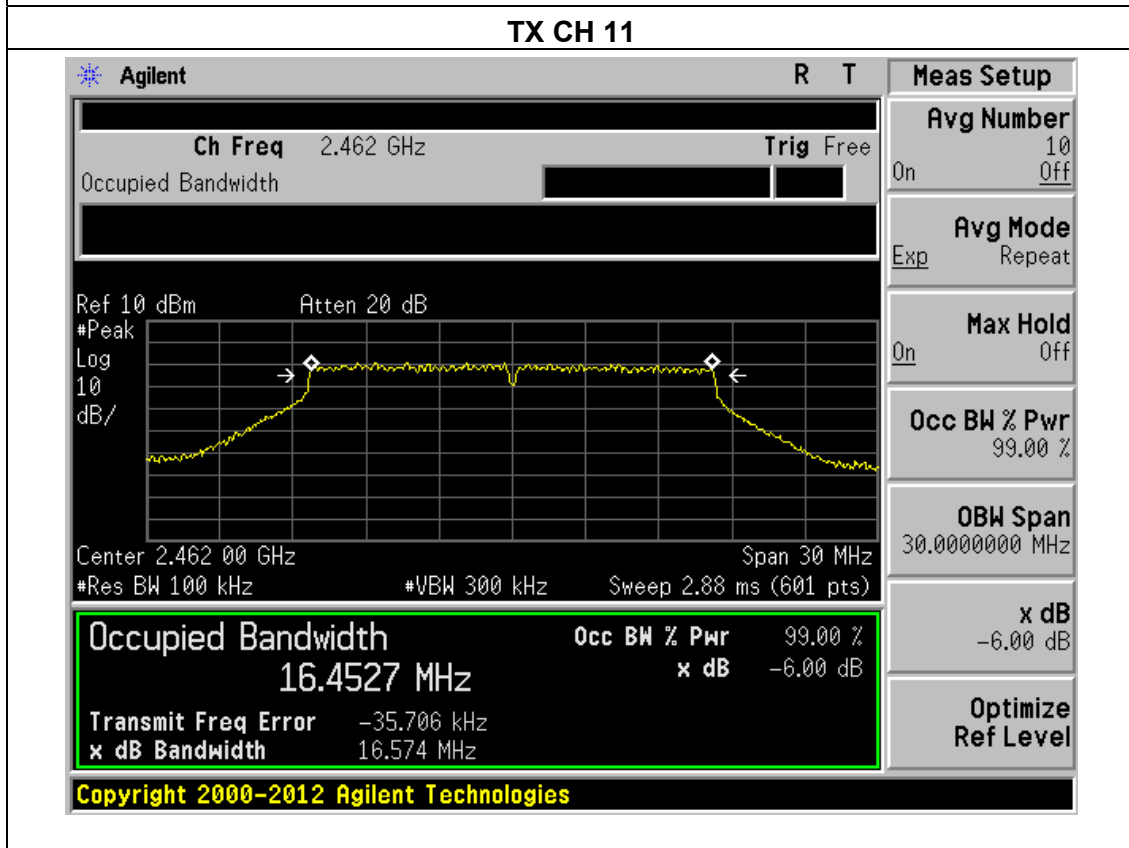
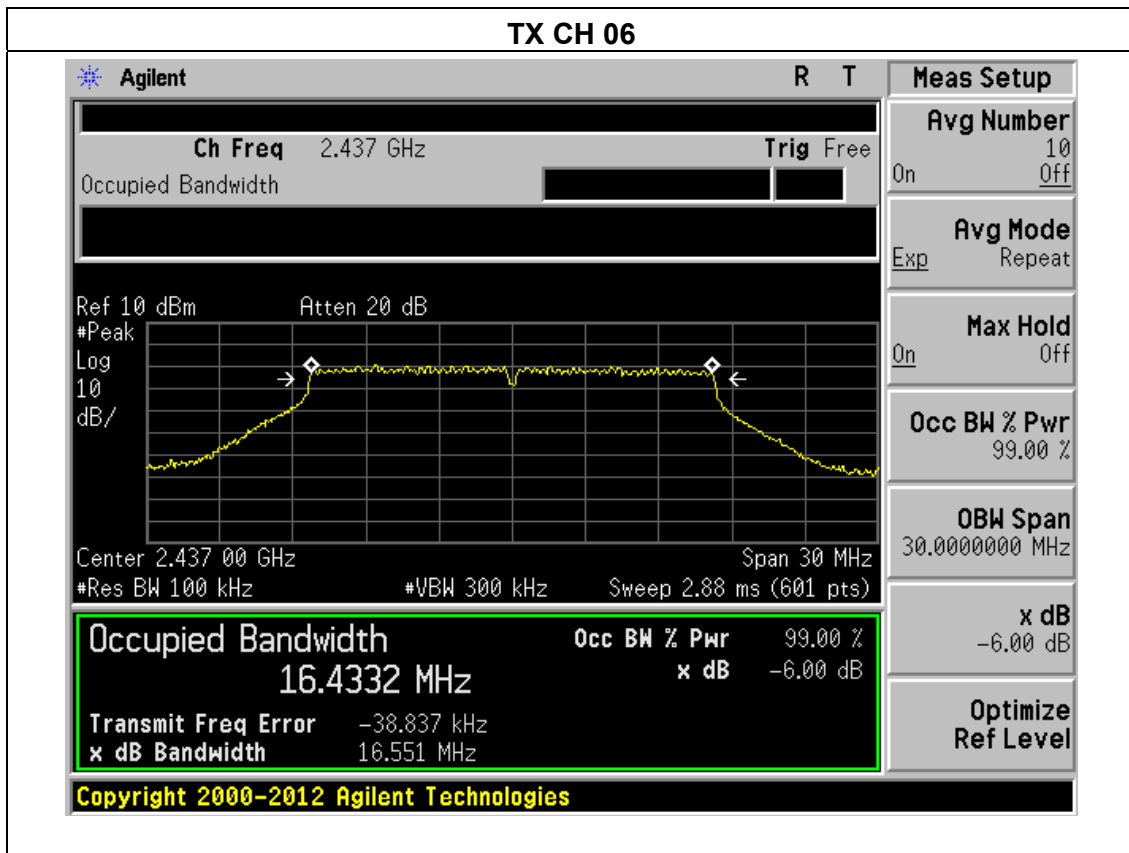



Ant.2

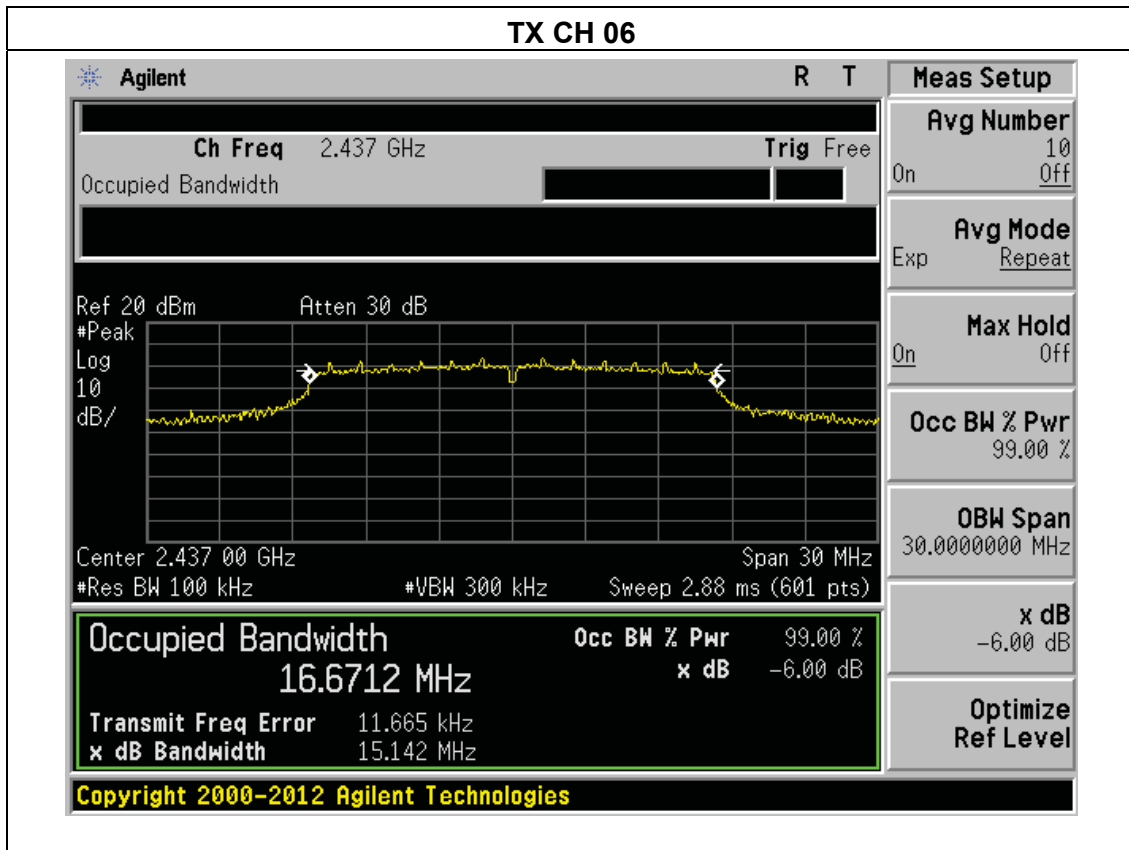
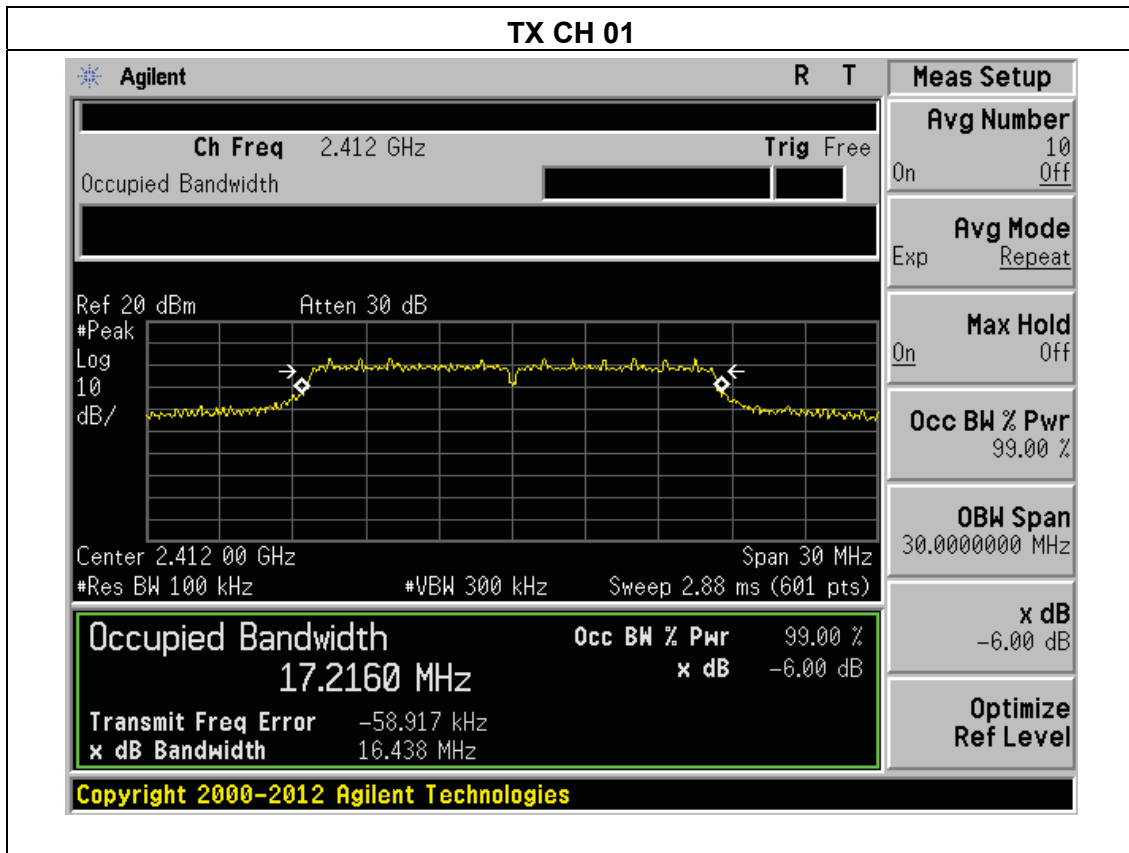

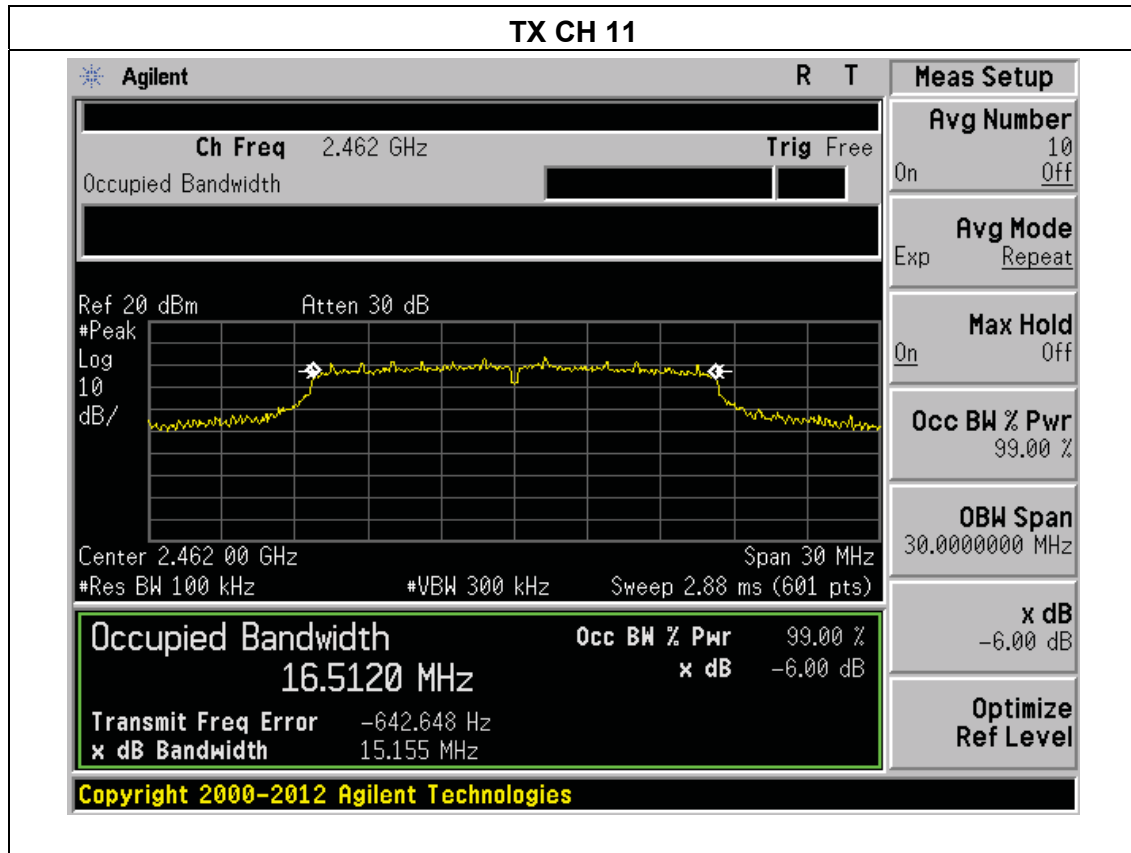





Temperature :	25°C	Relative Humidity :	60%
Pressure :	1012 hPa	Test Voltage :	DC 12V from adapter
Test Mode :	TX n Mode(20M)		

Channel	Frequency (MHz)	6dB bandwidth (MHz)		Limit (kHz)	Result
Low	2412	Ant.1	17.765	500	Pass
		Ant.2	16.101	500	Pass
Middle	2437	Ant.1	17.761	500	Pass
		Ant.2	15.188	500	Pass
High	2462	Ant.1	17.760	500	Pass
		Ant.2	15.119	500	Pass

Ant.1

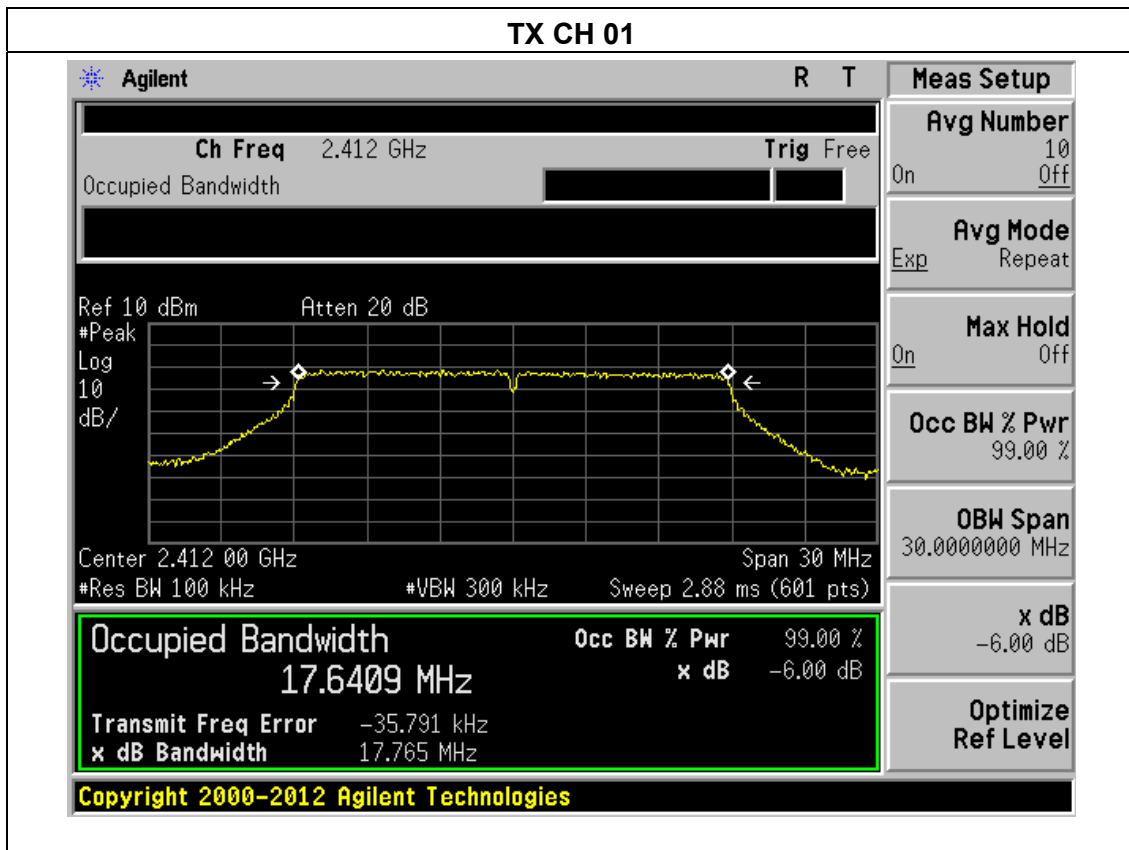

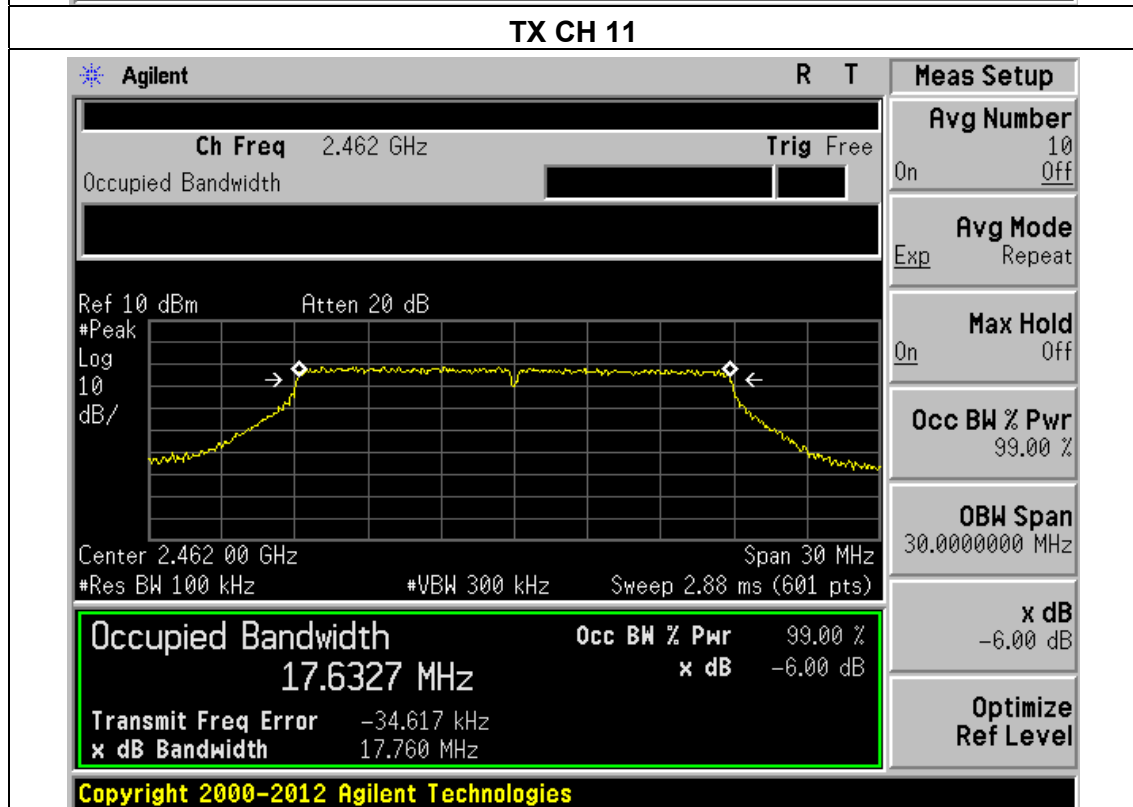
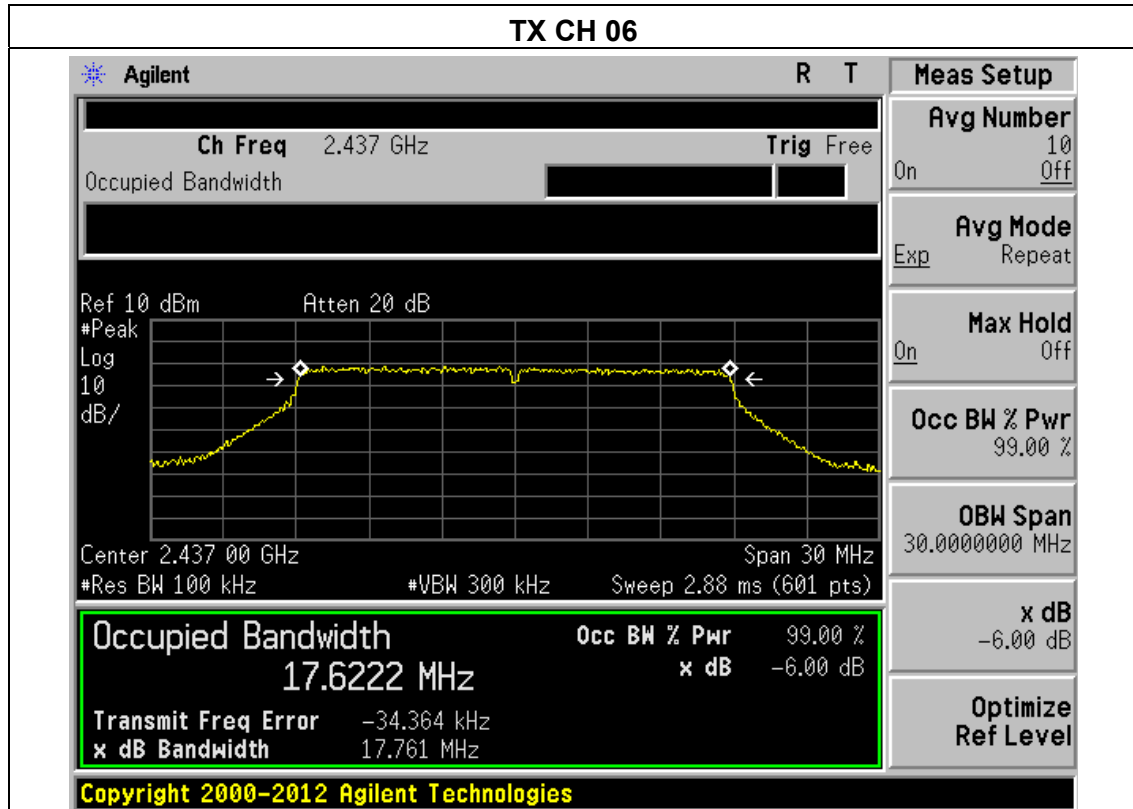



Ant.2

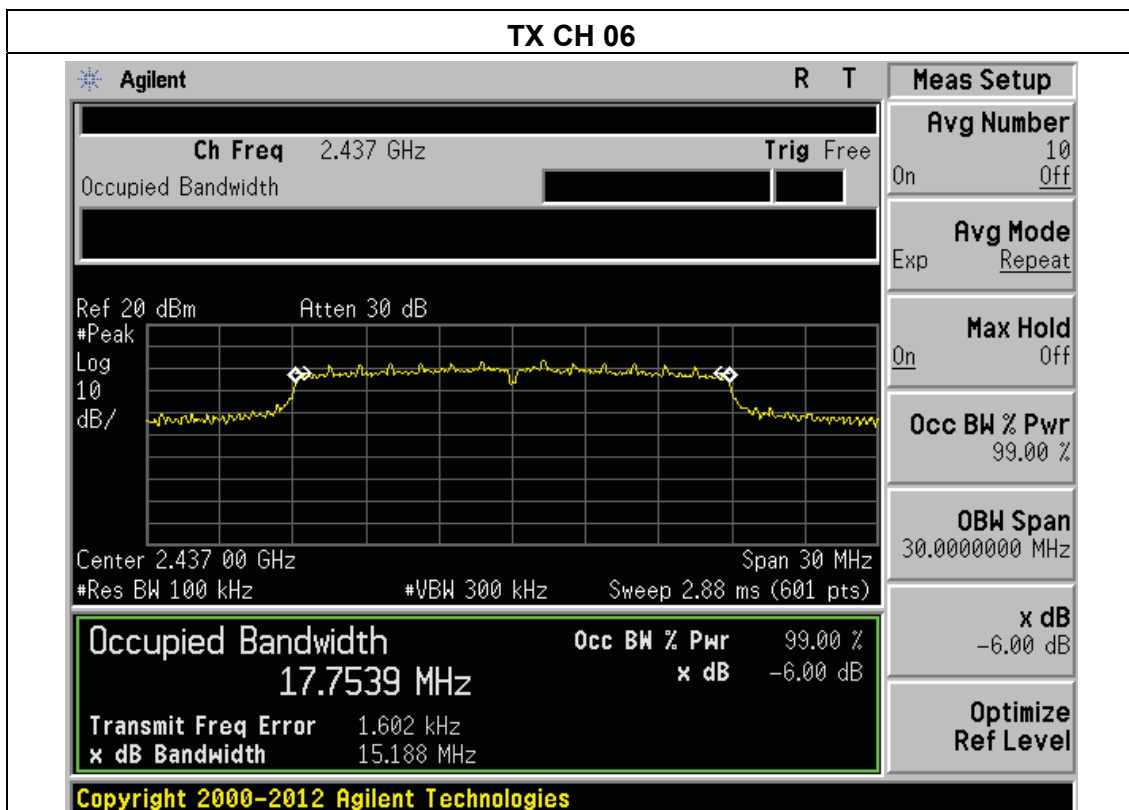
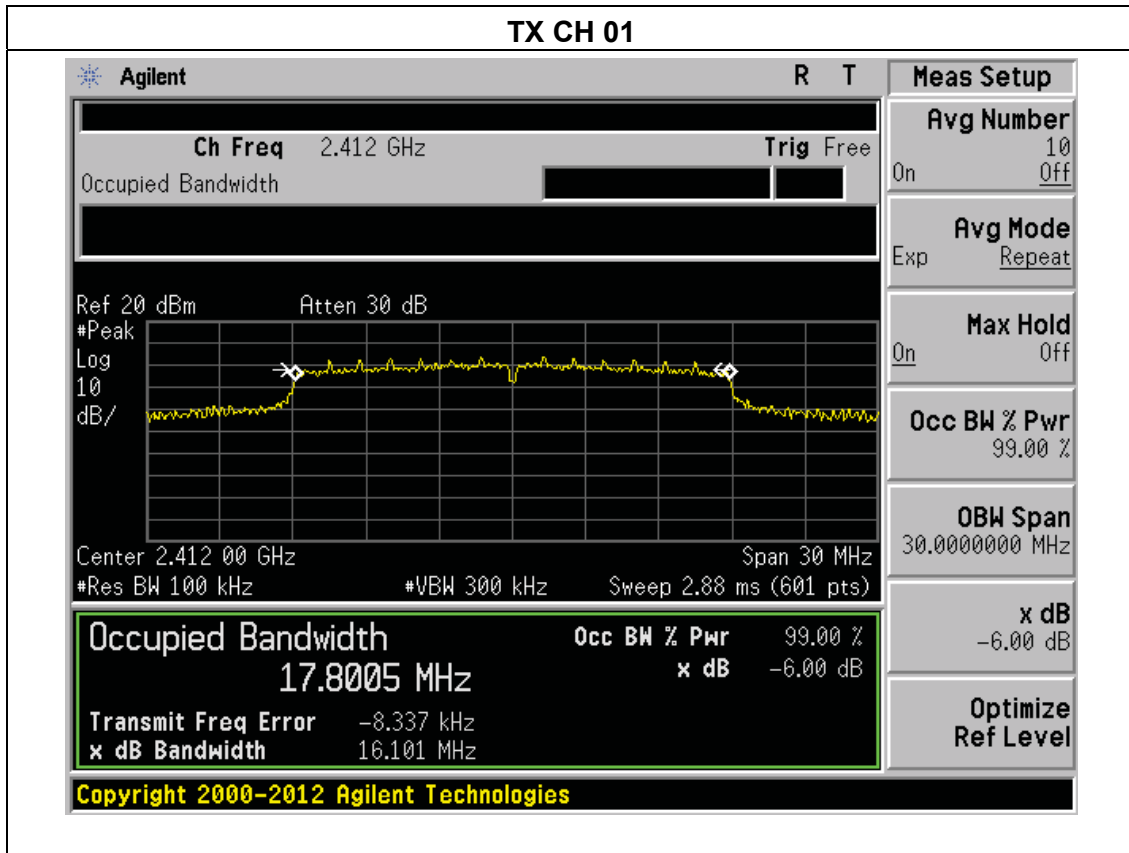

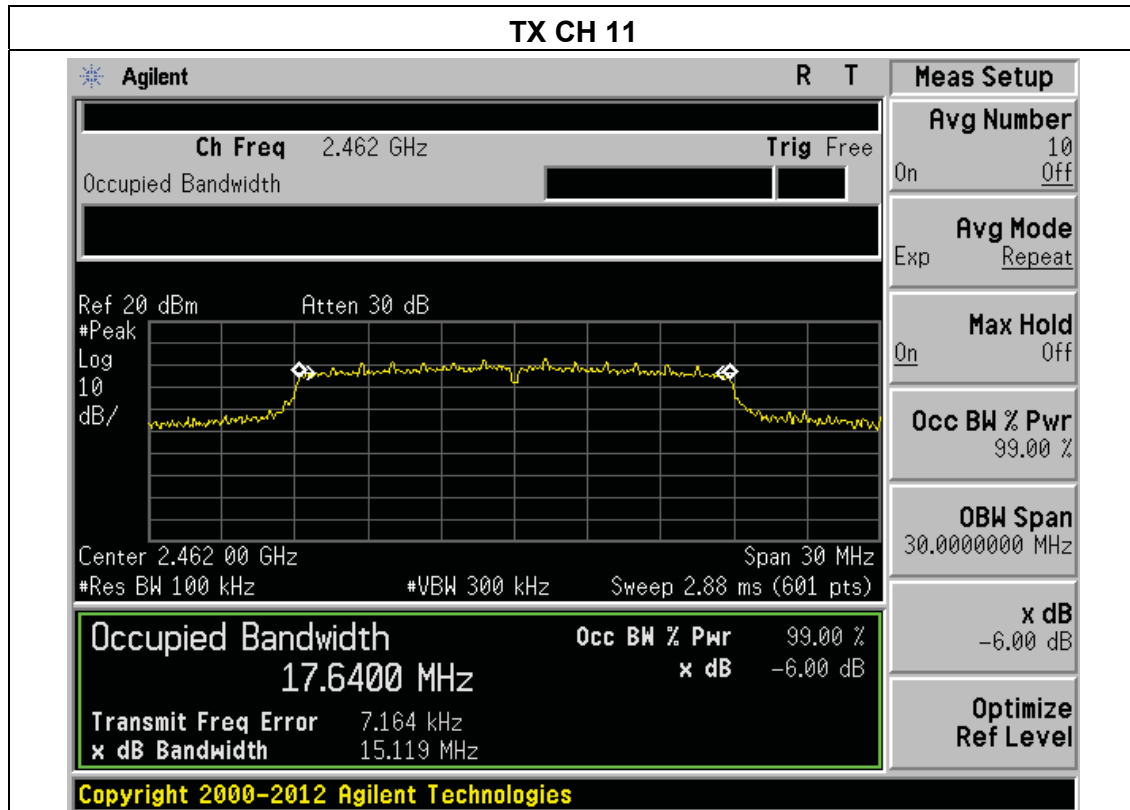



Temperature :	25°C	Relative Humidity :	60%
Pressure :	1012 hPa	Test Voltage :	DC 12V from adapter
Test Mode :	TX n Mode(40M)		

Channel	Frequency (MHz)	6dB bandwidth (MHz)		Limit (kHz)	Result
Low	2422	Ant.1	36.168	500	Pass
		Ant.2	36.352	500	Pass
Middle	2437	Ant.1	36.177	500	Pass
		Ant.2	35.235	500	Pass
High	2452	Ant.1	36.199	500	Pass
		Ant.2	35.325	500	Pass

Ant.1

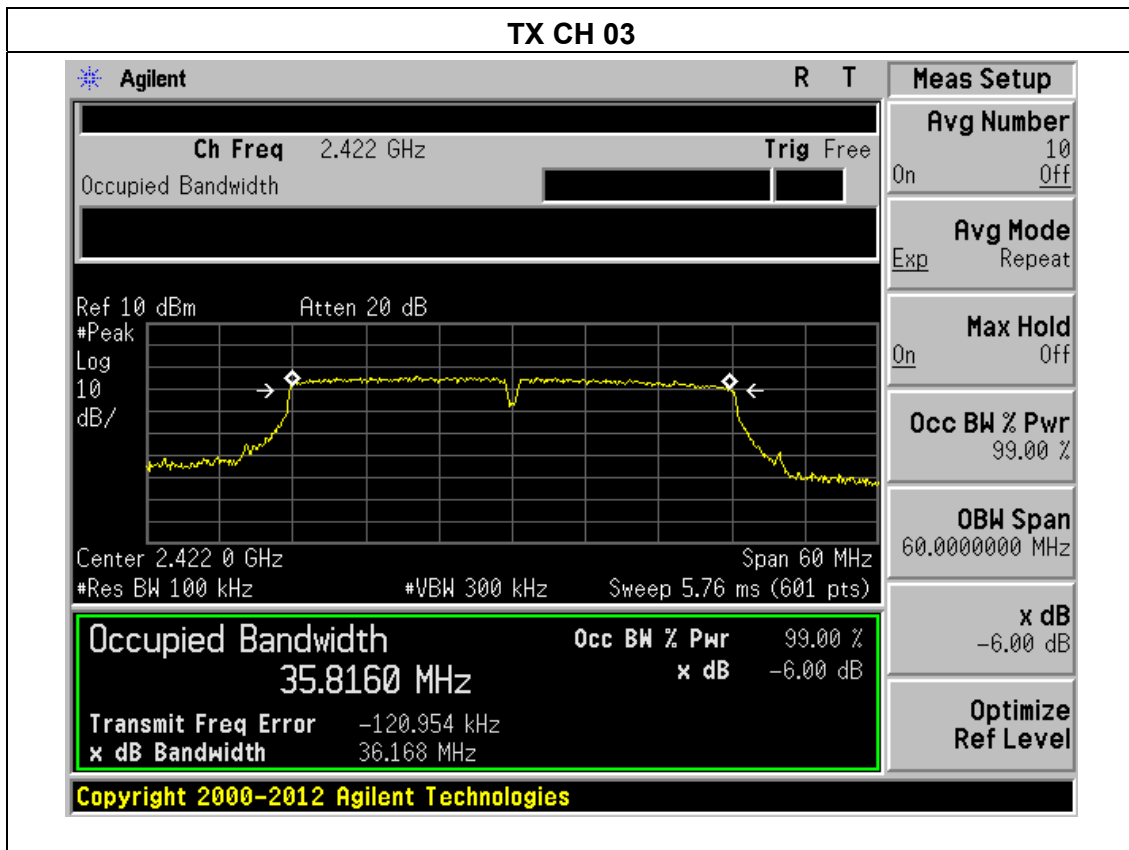

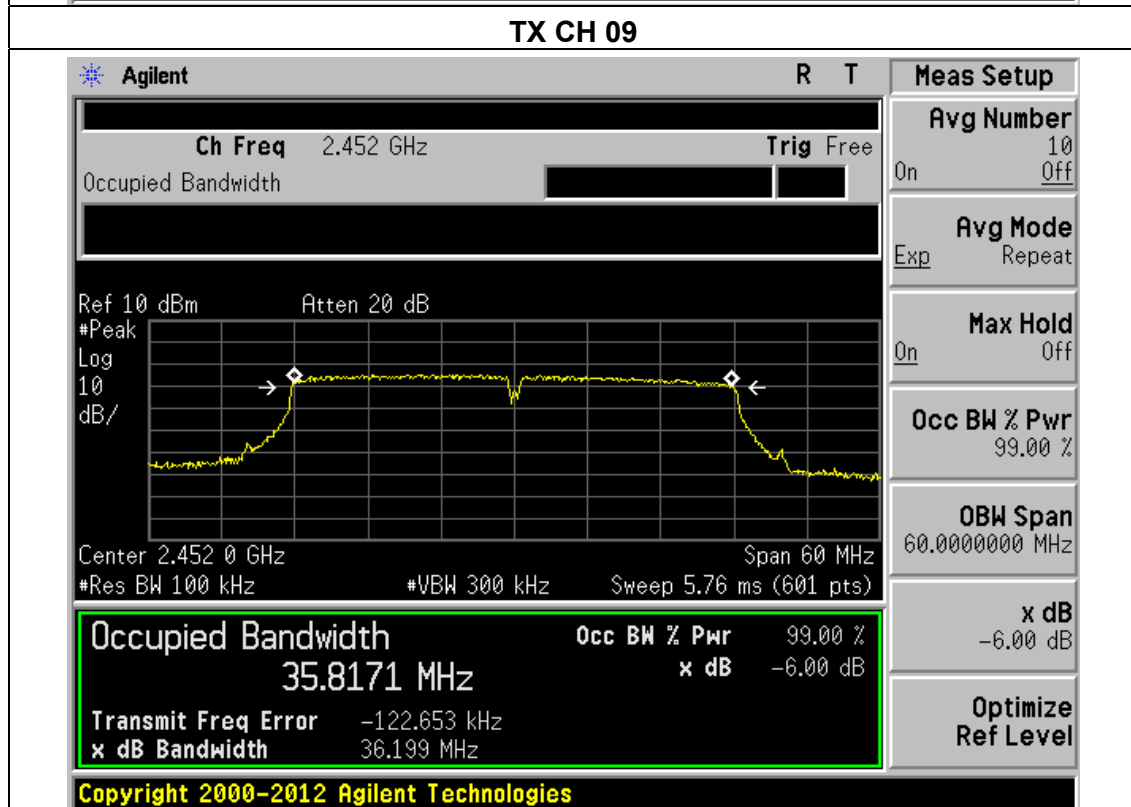
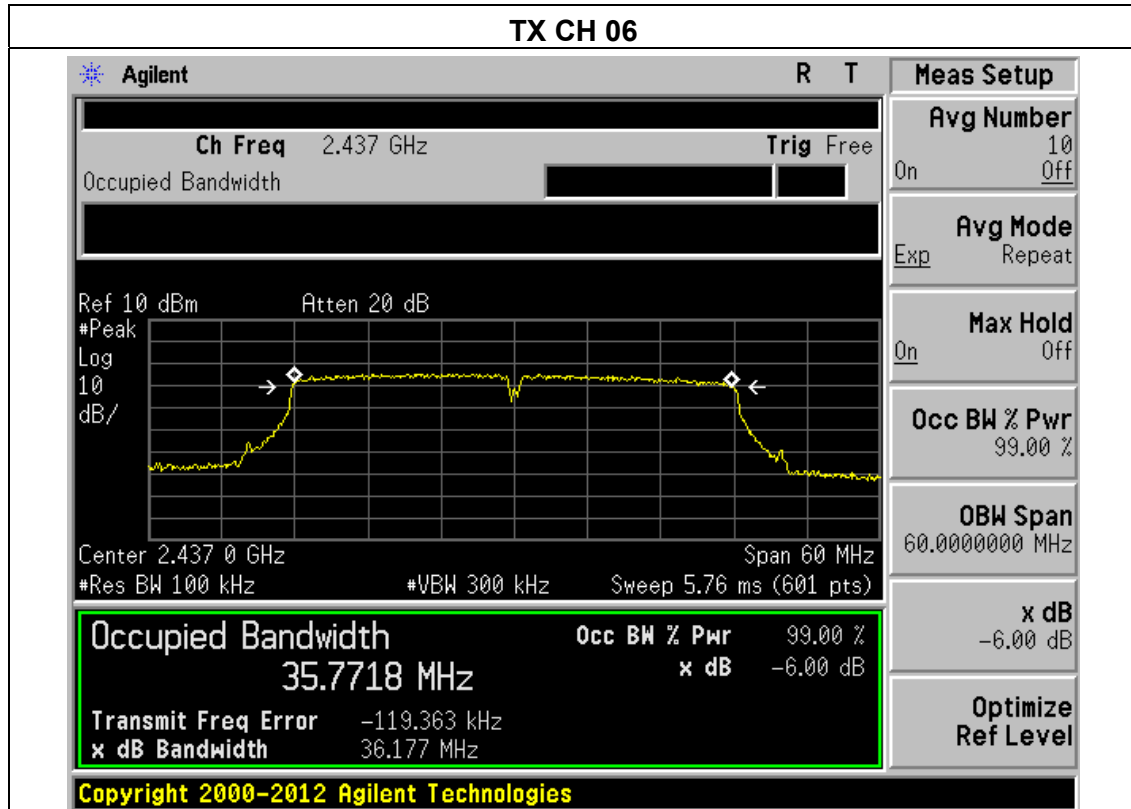



Ant.2

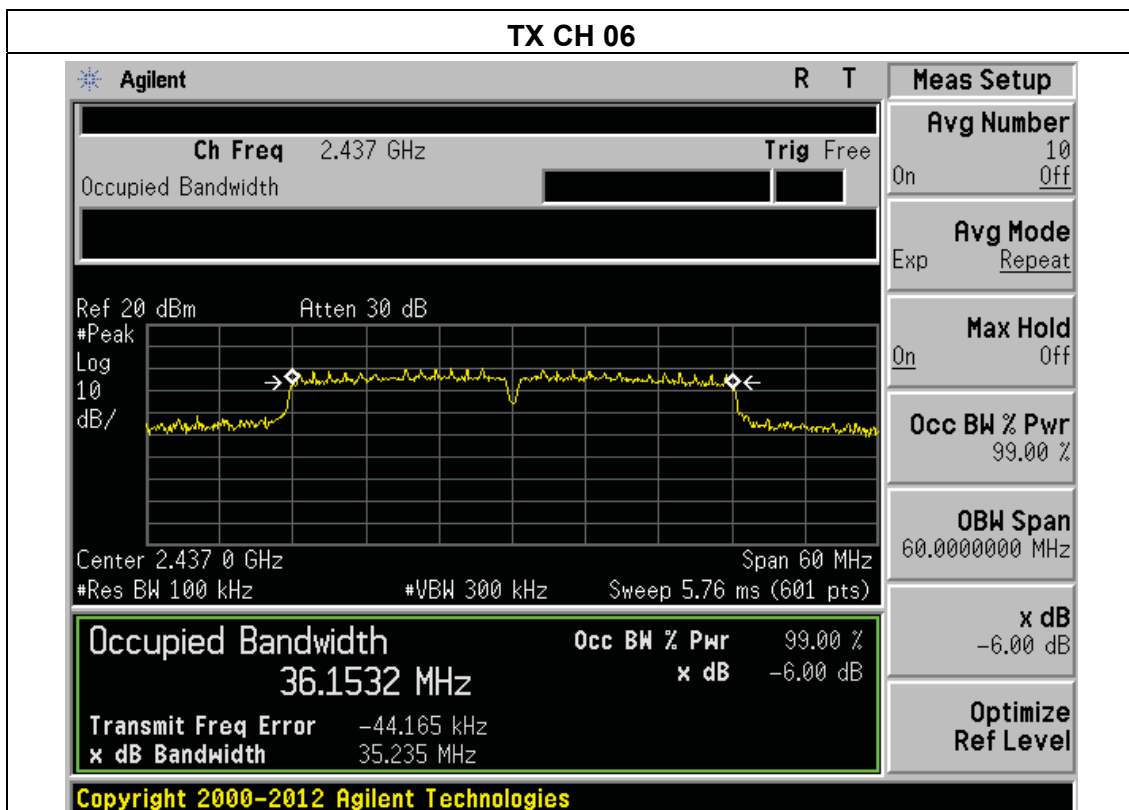
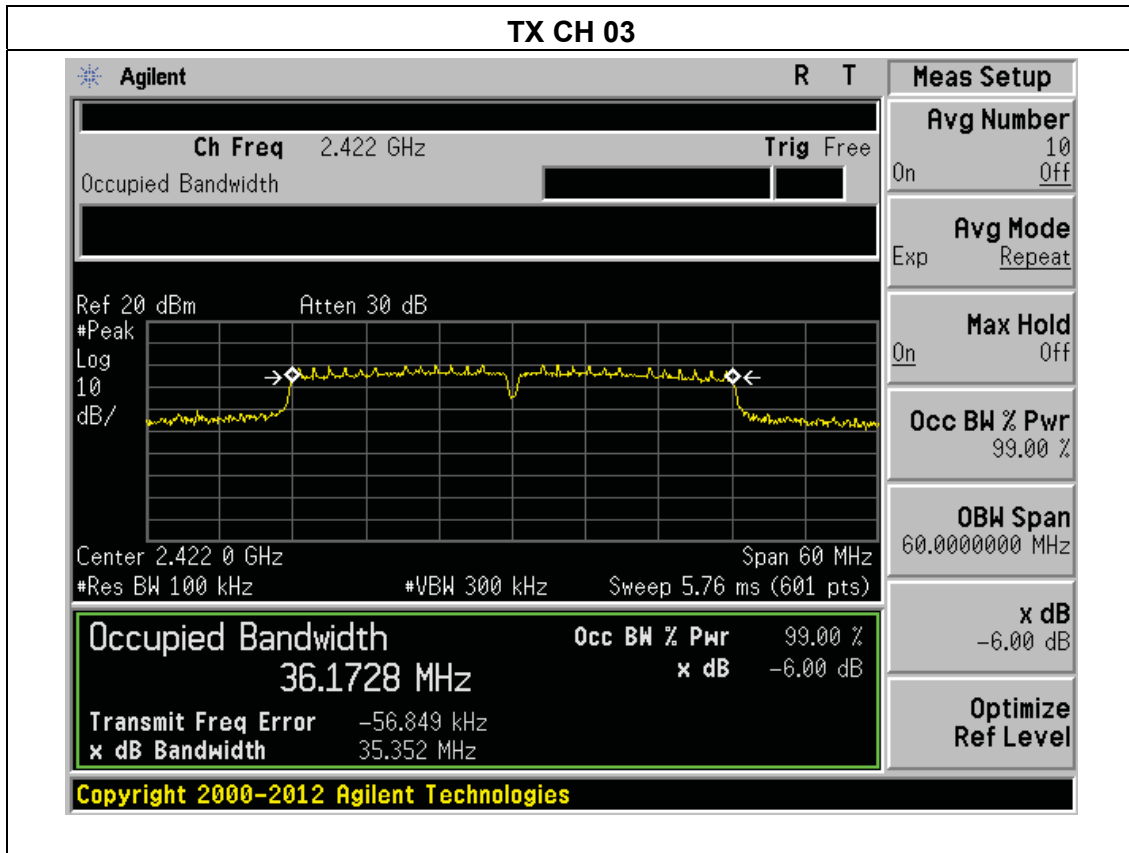

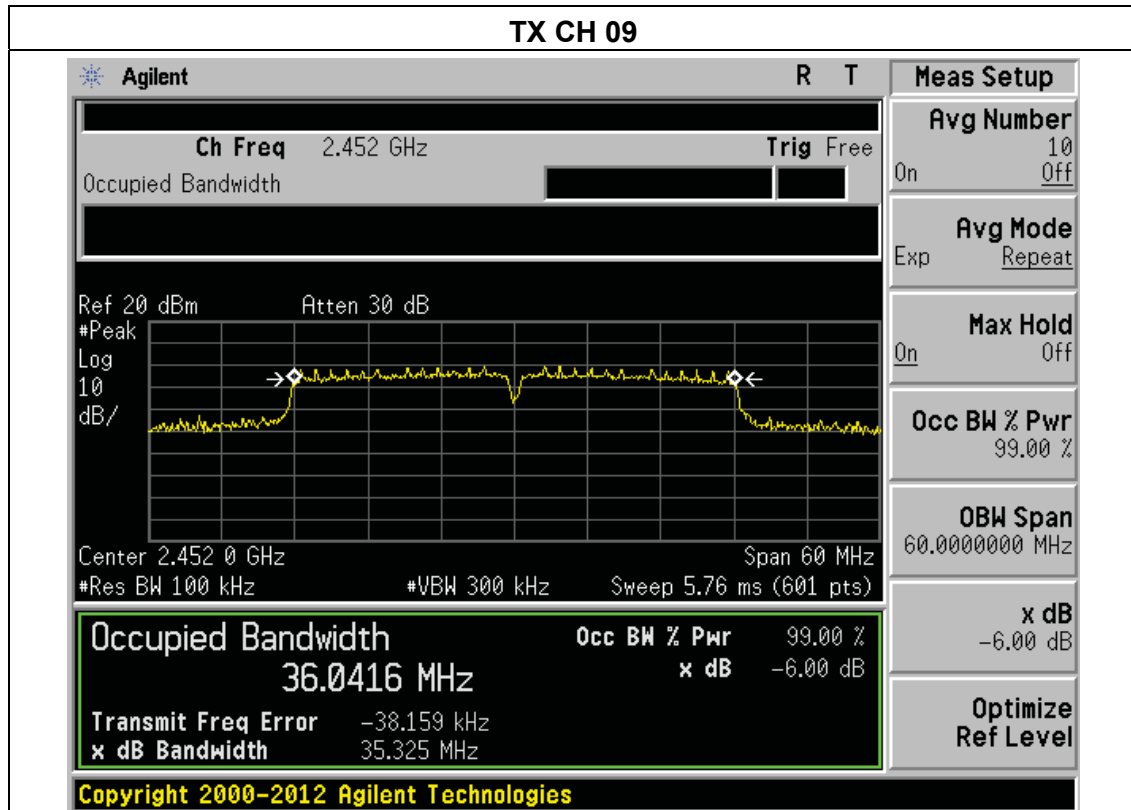





## 6. PEAK OUTPUT POWER TEST

### 6.1 APPLIED PROCEDURES / LIMIT

FCC Part15 (15.247) , Subpart C				
Section	Test Item	Limit	Frequency Range (MHz)	Result
15.247(b)(3)	Peak Output Power	1 watt or 30dBm	2400-2483.5	PASS

#### 6.1.1 TEST PROCEDURE

- a. The EUT was directly connected to the Power meter

#### 6.1.2 DEVIATION FROM STANDARD

No deviation.

#### 6.1.3 TEST SETUP



#### 6.1.4 EUT OPERATION CONDITIONS

The EUT tested system was configured as the statements of 2.4 Unless otherwise a special operating condition is specified in the follows during the testing.



**6.1.5 TEST RESULTS**

Temperature :	25°C	Relative Humidity :	60%
Pressure :	1012 hPa	Test Voltage :	DC 12V from adapter

	Frequency	Antenna port	Maximum Conducted Output Power(PK)	Maximum Conducted Output Power(PK)	Total Conducted Output Power(PK)	Total Conducted Output Power(PK)	LIMIT
	(MHz)		(dBm)	(mW)	(mW)	(dBm)	dBm
802.11b	2412	Ant.1	14.87	30.69	61.31	17.88	30
		Ant.2	14.86	30.62			
	2437	Ant.1	14.82	30.34	60.26	17.80	30
		Ant.2	14.76	29.92			
	2462	Ant.1	14.83	30.41	61.10	17.86	30
		Ant.2	14.87	30.69			
802.11g	2412	Ant.1	12.69	18.58	37.24	15.71	30
		Ant.2	12.71	18.66			
	2437	Ant.1	12.73	18.75	37.59	15.75	30
		Ant.2	12.75	18.84			
	2462	Ant.1	12.72	18.71	37.37	15.73	30
		Ant.2	12.71	18.66			
802.11n20	2412	Ant.1	11.54	14.26	27.91	14.14	30
		Ant.2	11.35	13.65			
	2437	Ant.1	11.57	14.35	27.72	14.46	30
		Ant.2	11.26	13.37			
	2462	Ant.1	11.49	14.09	27.61	14.41	30
		Ant.2	11.31	13.52			
802.11n40	2422	Ant.1	9.87	9.71	18.16	12.59	30
		Ant.2	9.27	8.45			
	2437	Ant.1	9.79	9.53	17.98	12.55	30
		Ant.2	9.27	8.45			
	2452	Ant.1	9.79	9.53	18.12	12.58	30
		Ant.2	9.34	8.59			



## 7. 100 KHZ BANDWIDTH OF FREQUENCY BAND EDGE

### 7.1 APPLICABLE STANDARD

In any 100 kHz bandwidth outside the frequency band in which the spread spectrum or digitally modulated intentional radiator is operating, the radio frequency power that is produced by the intentional radiator shall be at least 20 dB below that in the 100 kHz bandwidth within the band that contains the highest level of the desired power, based on either an RF conducted or a radiated measurement, provided the transmitter demonstrates compliance with the peak conducted power limits. If the transmitter complies with the conducted power limits based on the use of RMS averaging over a time interval, as permitted under paragraph (b)(3) of this section, the attenuation required under this paragraph shall be 30 dB instead of 20 dB. Attenuation below the general limits specified in §15.209(a) is not required. In addition, radiated emissions which fall in the restricted bands, as defined in §15.205(a), must also comply with the radiated emission limits specified in §15.209(a) (see §15.205(c)).

### 7.2 TEST PROCEDURE

- a) Check the calibration of the measuring instrument using either an internal calibrator or a known signal from an external generator.
- b) Position the EUT without connection to measurement instrument. Turn on the EUT and connect its antenna terminal to measurement instrument via a low loss cable. Then set it to any one measured frequency within its operating range, and make sure the instrument is operated in its linear range.
- c) Set RBW to 100 kHz and VBW of spectrum analyzer to 300 kHz with a convenient frequency span including 100 kHz bandwidth from band edge.
- d) Measure the highest amplitude appearing on spectral display and set it as a reference level. Plot the graph with marking the highest point and edge frequency.
- e) Repeat above procedures until all measured frequencies were complete.

### 7.3 DEVIATION FROM STANDARD

No deviation.

### 7.4 TEST SETUP

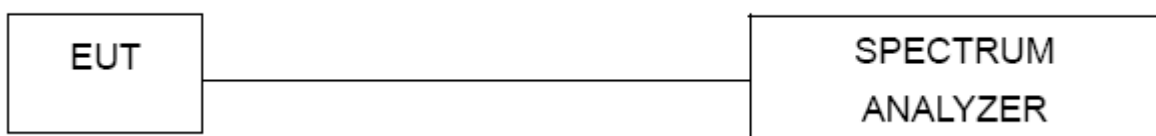



## **7.5 EUT OPERATION CONDITIONS**

The EUT tested system was configured as the statements of 2.4 Unless otherwise a special operating condition is specified in the follows during the testing.

## **7.1 TEST RESULTS**



Ant.1

802.11b: Band Edge, Left Side

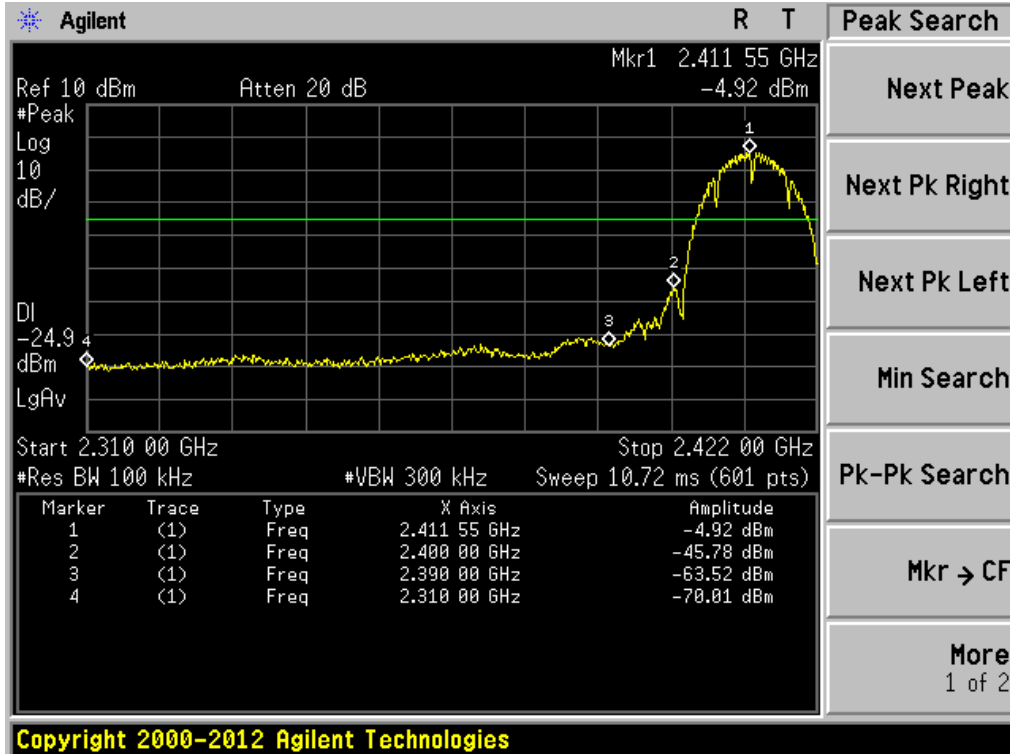

802.11b: Band Edge, Right Side





802.11g: Band Edge, Left Side

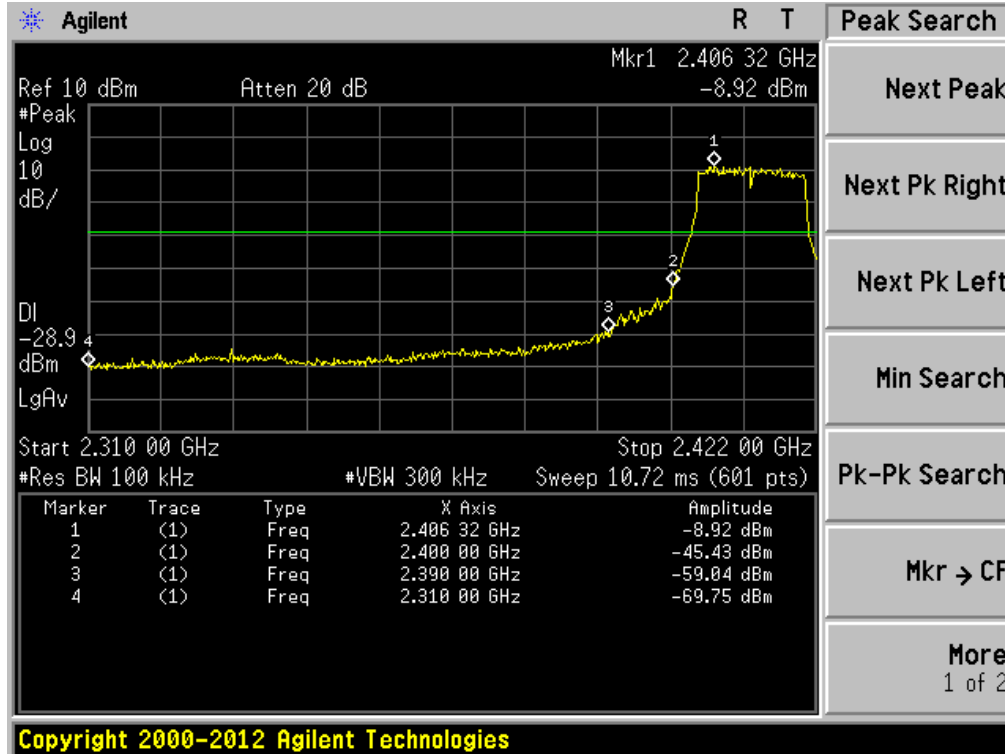

802.11g: Band Edge, Right Side

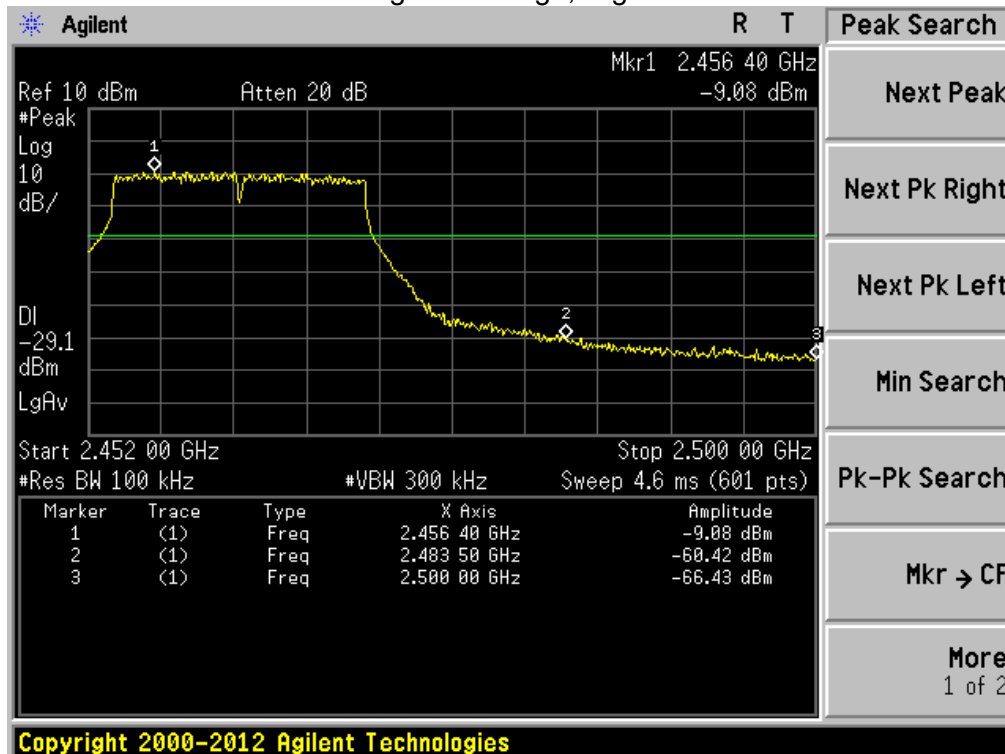



802.11n-HT20: Band Edge, Left Side

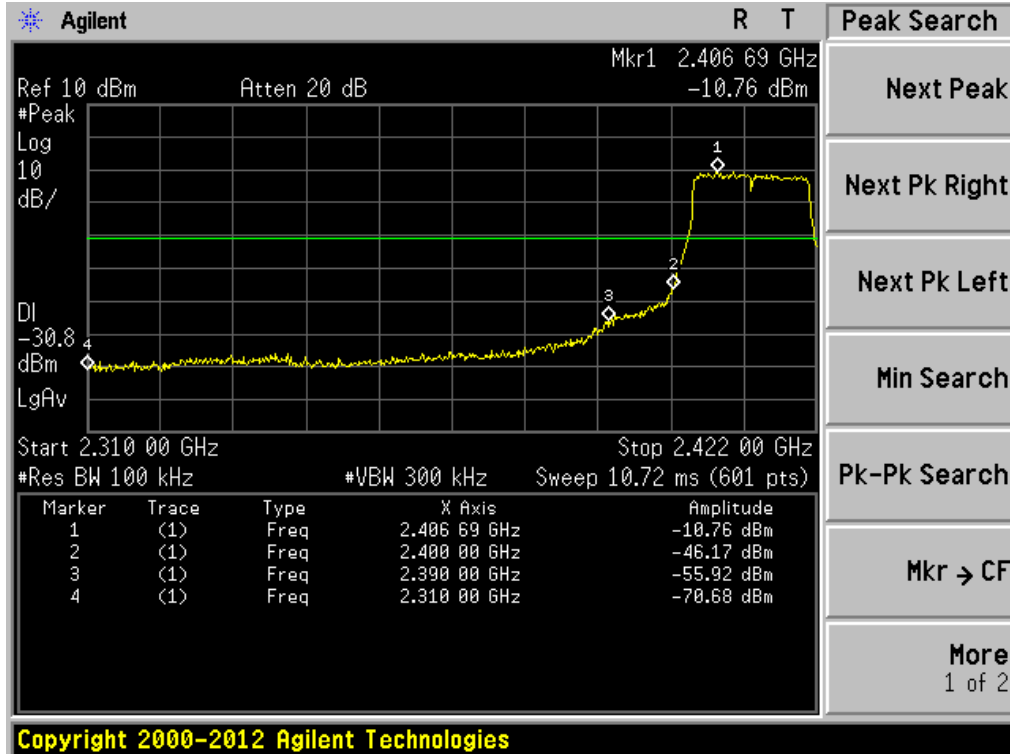

802.11n-HT20: Band Edge, Right Side

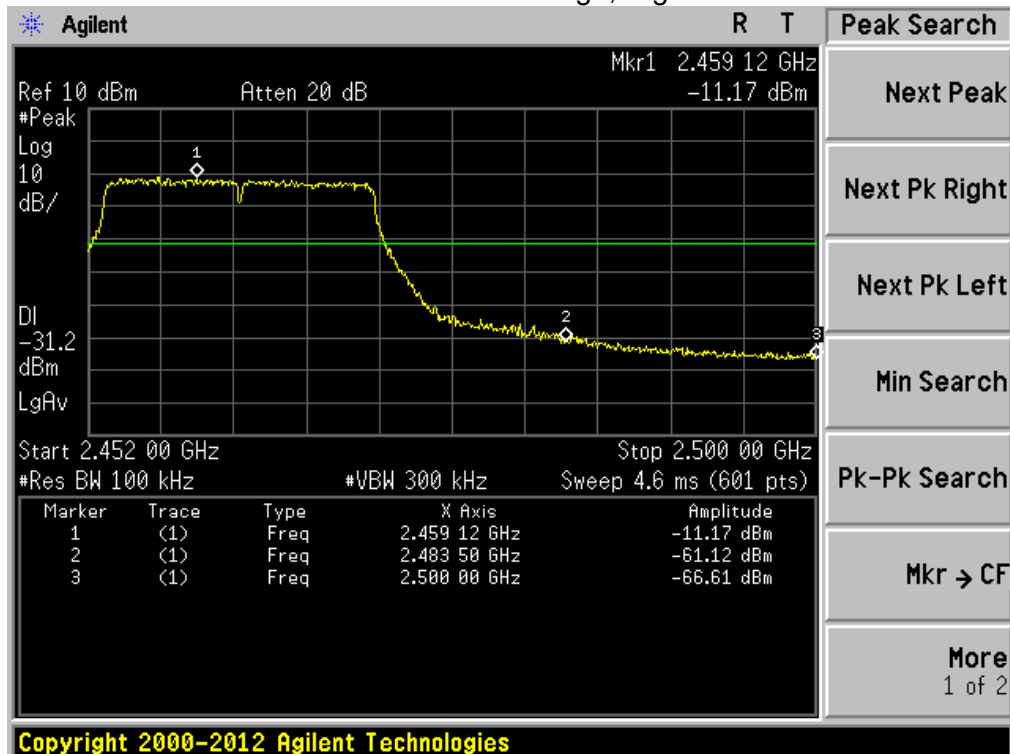



802.11n-HT40: Band Edge, Left Side

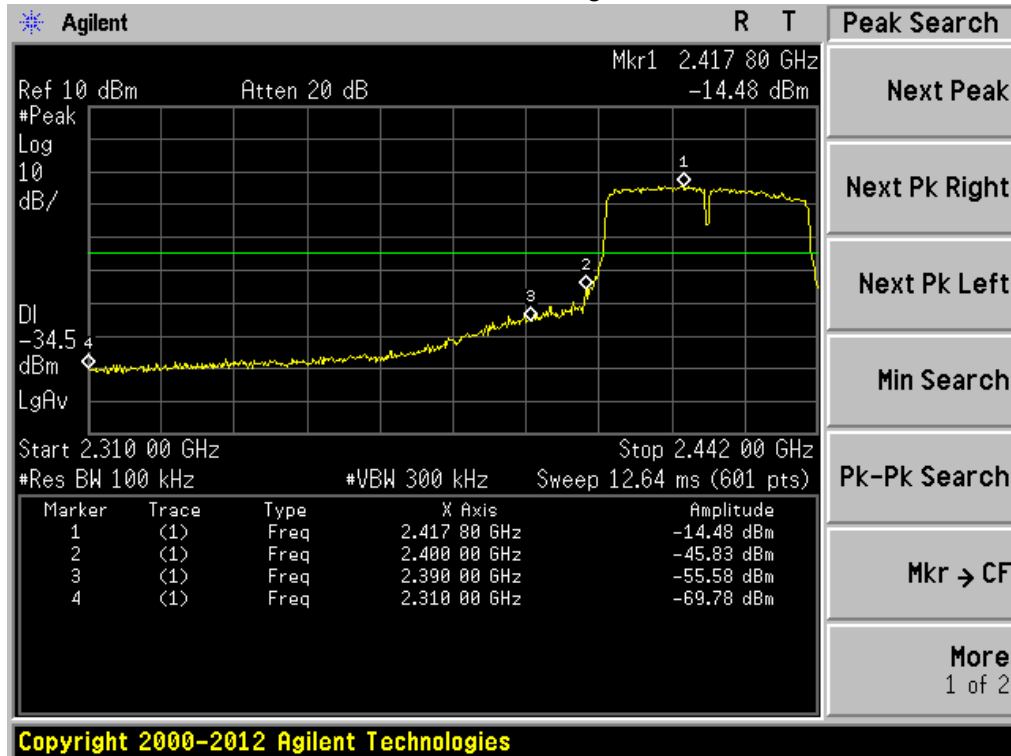

802.11n-HT40: Band Edge, Right Side

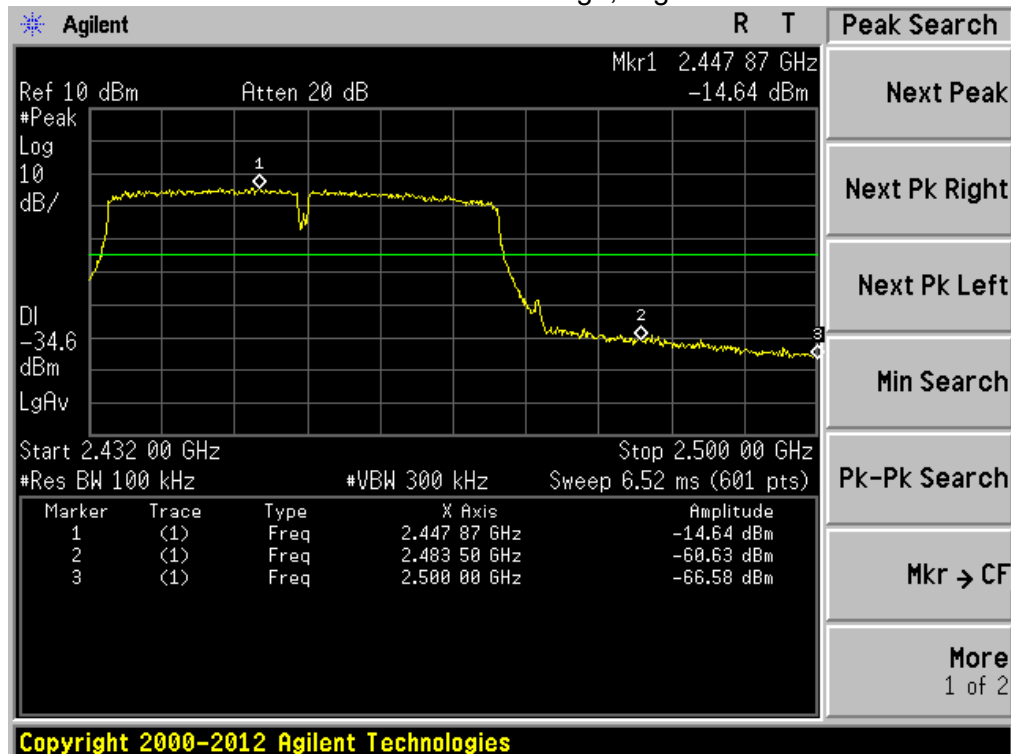





Ant.2

802.11b: Band Edge, Left Side

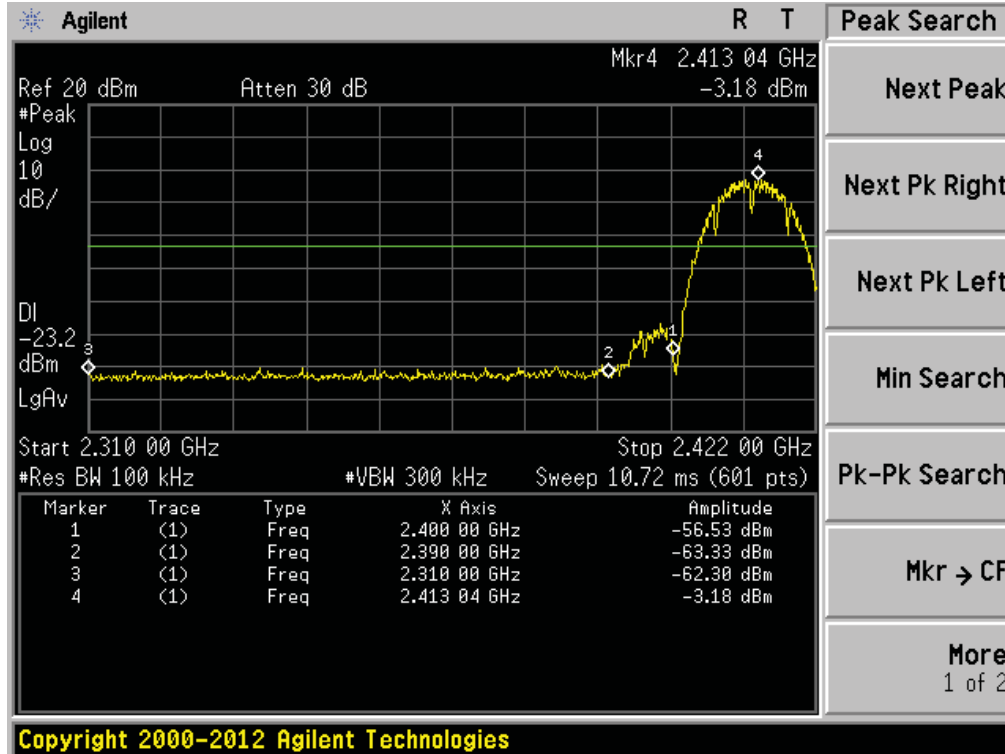

802.11b: Band Edge, Right Side

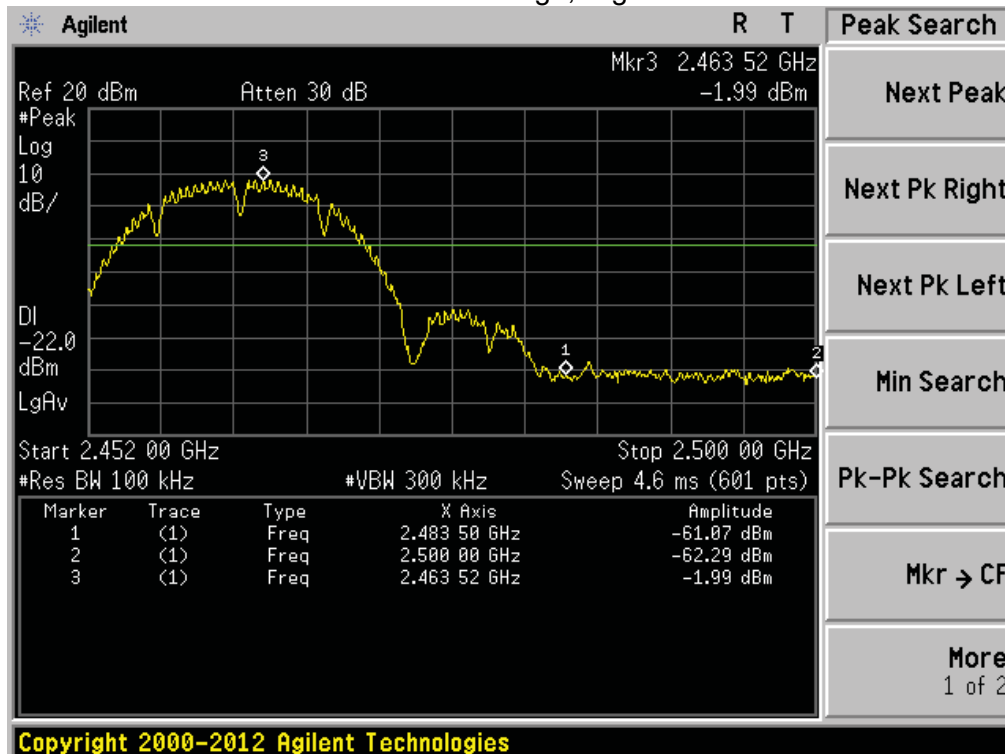



802.11g: Band Edge, Left Side

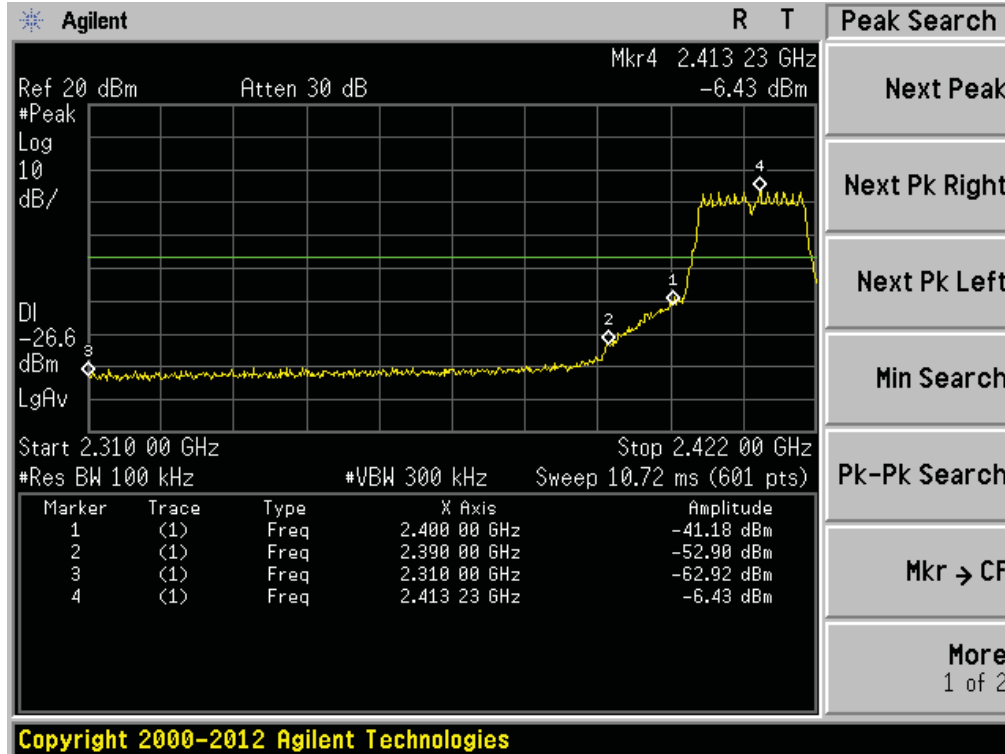

802.11g: Band Edge, Right Side

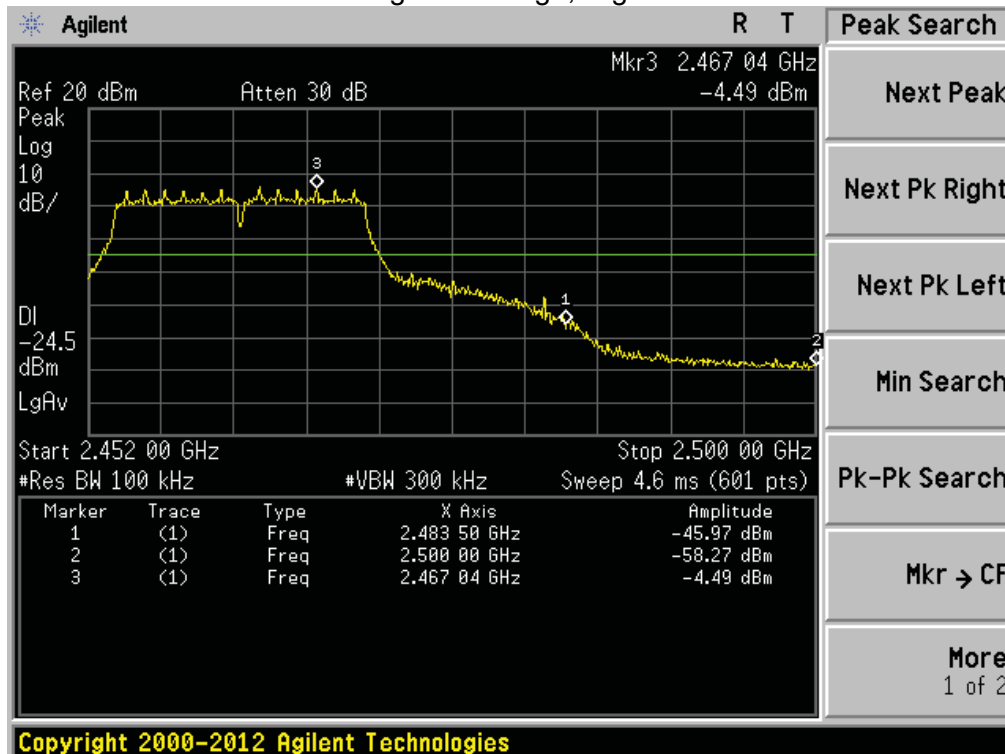



802.11n-HT20: Band Edge, Left Side

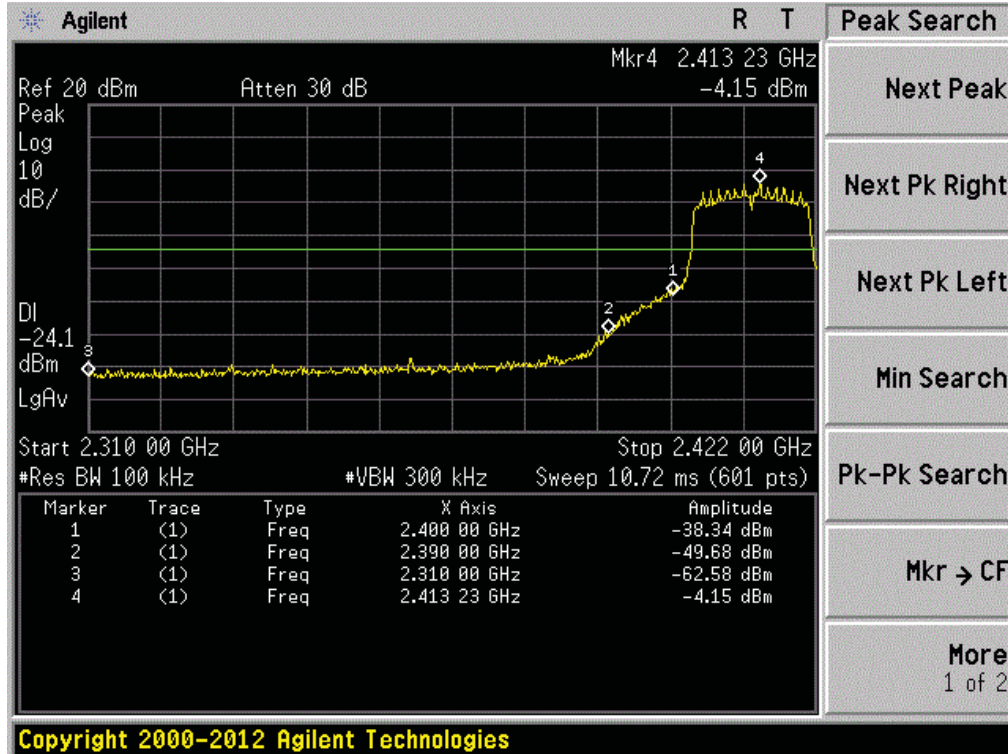

802.11n-HT20: Band Edge, Right Side

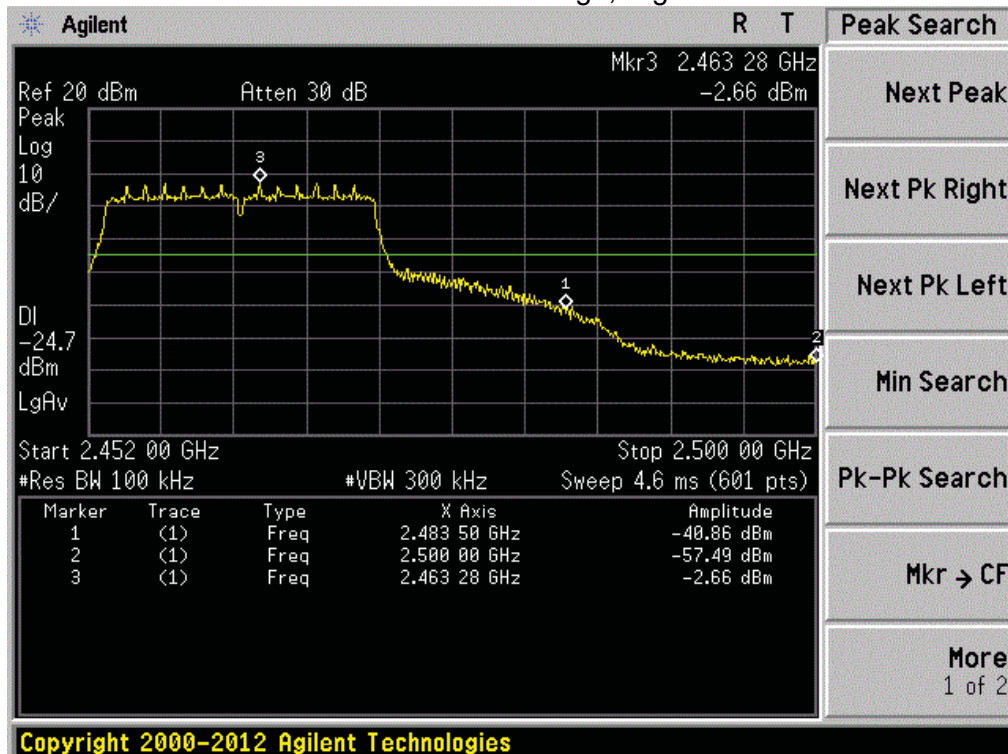



802.11n-HT40: Band Edge, Left Side

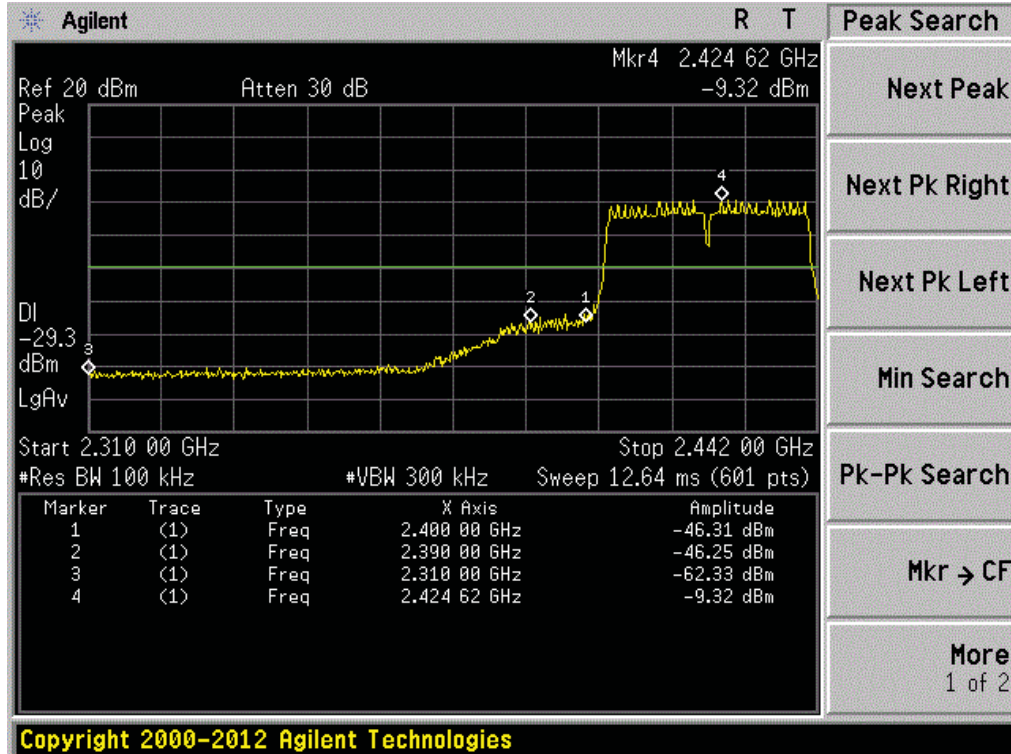

802.11n-HT40: Band Edge, Right Side

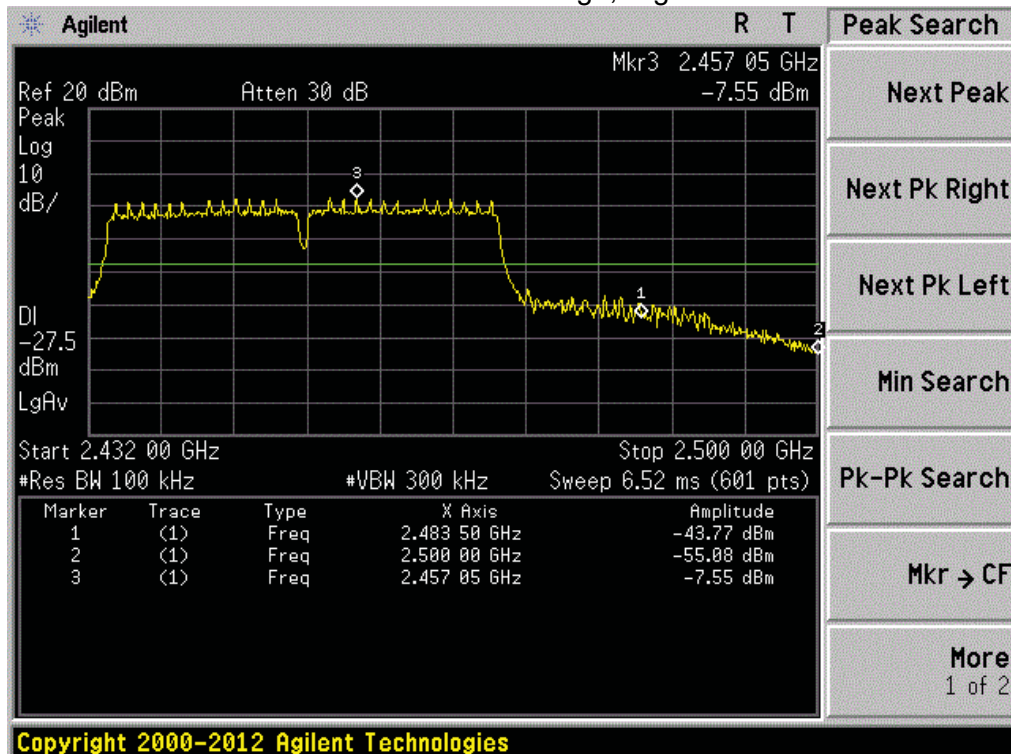



## **8. ANTENNA REQUIREMENT**

### **8.1 STANDARD REQUIREMENT**

15.203 requirement: For intentional device, according to 15.203: an intentional radiator shall be designed to ensure that no antenna other than that furnished by the responsible party shall be used with the device.

### **8.2 EUT ANTENNA**

The EUT antenna is external antenna, use of anti thread antenna, It comply with the standard requirement.



## 9. EUT TEST PHOTO

### Radiated Measurement Photos



### Radiated Measurement Photos

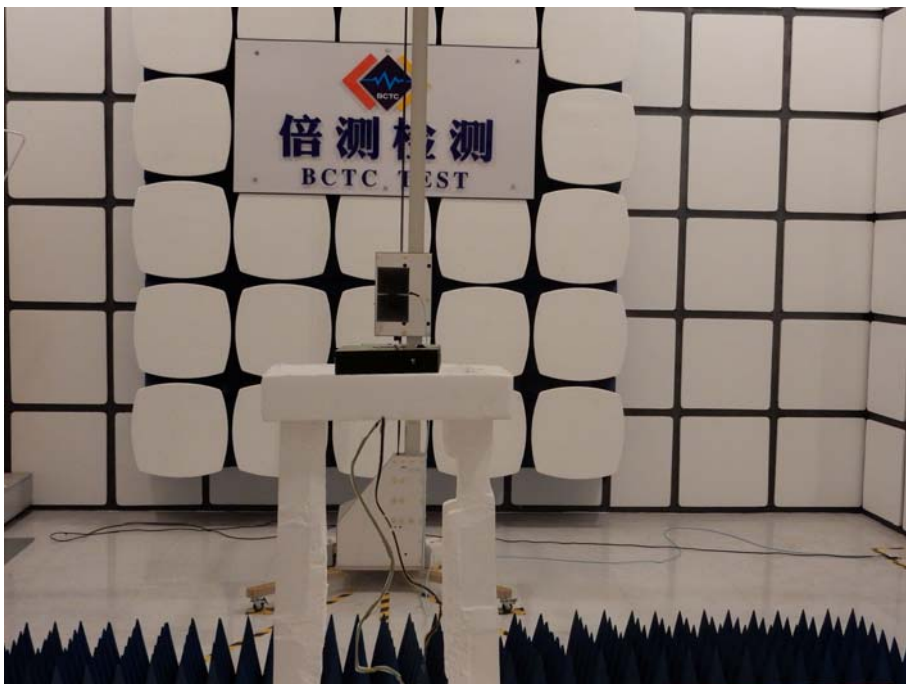



### Conducted Measurement Photos



### 10. EUT PHOTO











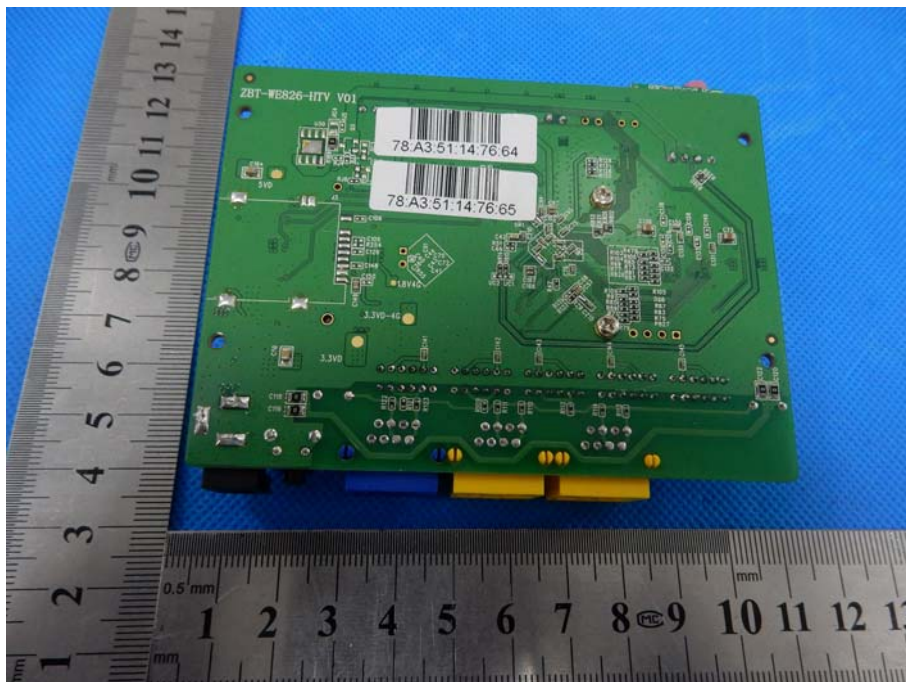



\*\*\*\*\* END OF REPORT \*\*\*\*\*