



SAR TEST REPORT

Report No.: SET2020-04221

Product: HARMAN Spark

Brand Name: Harman

Model No.: HSA-15UA-BR

FCC ID: 2AHPN-HSA-15UA-BR

Applicant: Harman International Industries Incorporated

Address: 636, Ellis St, Mountain View, CA 94043, USA

Issued by: CCIC Southern Testing Co., Ltd.

Lab Location: Electronic Testing Building, No. 43 Shahe Road, Xili Street, Nanshan District, Shenzhen, Guangdong, China.

Tel: 86 755 26627338 **Fax:** 86 755 26627238

Mail: manager@ccic-set.com **Website:** <http://www.ccic-set.com>

This test report consists of 47 pages in total. It may be duplicated completely for legal use with the approval of the applicant. It should not be reproduced except in full, without the written approval of our laboratory. The client should not use it to claim product endorsement by CCIC-SET. The test results in the report only apply to the tested sample. The test report shall be invalid without all the signatures of testing engineers, reviewer and approver. Any objections must be raised to CCIC-SET within 15 days since the date when the report is received. It will not be taken into consideration beyond this limit.



Test Report

Product: HARMAN Spark
Model No.: HSA-15UA-BR
Brand Name.....: Harman
FCC ID.....: 2AHPN-HSA-15UA-BR
Applicant.....: Harman International Industries Incorporated
Applicant Address.....: 636, Ellis St, Mountain View, CA 94043, USA
Manufacturer.....: Harman International Industries Incorporated
Manufacturer Address: 636, Ellis St, Mountain View, CA 94043, USA
Test Standards.....: **47CFR §2.1093-** Radiofrequency Radiation Exposure Evaluation: Portable Devices;
ANSI C95.1–1992: Safety Levels with Respect to Human Exposure to Radio Frequency Electromagnetic Fields, 3 kHz – 300 GHz.(IEEE Std C95.1-1991)
IEEE 1528–2013: IEEE Recommended Practice for Determining the Peak Spatial-Average Specific Absorption Rate (SAR) in the Human Head from Wireless Communications Devices: Measurement Techniques
Test Result.....: Pass
Test Date.....: 2020.05.10-2020.05.16
Tested by: Mei Chun 2020-06-09
Mei Chun, Test Engineer
Reviewed by.....: Chris You 2020-06-09
Chris You, Senior Engineer
Approved by.....: Shuangwen Zhang 2020-06-09
Shuangwen Zhang, Manager



Contents

Test Report	2
1. Administrative Data.....	4
2. Equipment Under Test (EUT).....	5
3. SAR Summary.....	7
4. Specific Absorption Rate (SAR).....	8
5. Tissue check and recommend Dielectric Parameters	12
6. SAR measurement procedure	17
7. Conducted RF Output Power	18
8. Scaling Factor calculation	33
9. Test Results	34
10. Simultaneous Transmissions Analysis.....	41
11. Measurement Uncertainty.....	42
12. Equipment List.....	46
ANNEX A: Appendix A: SAR System performance Check Plots.....	47
ANNEX B: Appendix B: SAR Measurement results Plots.....	47
ANNEX C: Appendix C: Calibration reports	47
ANNEX D: Appendix D: SAR Test Setup.....	47



1. Administrative Data

1.1 Testing Laboratory

Test Site: CCIC Southern Testing Co., Ltd.

Address: Electronic Testing Building, No. 43 Shahe Road, Xili Street, Nanshan District, Shenzhen, Guangdong, China

CNAS Lab Code: CCIC-SET is a third party testing organization accredited by China National Accreditation Service for Conformity Assessment (CNAS) according to ISO/IEC 17025. The accreditation certificate number is L1659.

NVLAP Lab Code: CCIC-SET is a third party testing organization accredited by NVLAP according to ISO/IEC 17025. The accreditation certificate number is 201008-0.

FCC Registration: CCIC Southern Electronic Product Testing (Shenzhen) Co., Ltd. EMC Laboratory has been registered and fully described in a report filed with the FCC (Federal Communications Commission). The acceptance letter from the FCC is maintained in our files. Designation Number: CN5031, valid time is until December 31, 2020.

ISED Registration: CCIC Southern Electronic Product Testing (Shenzhen) Co., Ltd. EMC Laboratory has been registered by Certification and Engineering Bureau of Industry Canada for the performance of radiated measurements with Registration No. 11185A-1 on Aug. 04, 2016, valid time is until December 31, 2020.

Test Environment Temperature (°C): 21 °C

Condition: Relative Humidity (%): 60%

Atmospheric Pressure (kPa): 86KPa-106KPa

2. Equipment Under Test (EUT)

Identification of the Equipment under Test

Device Type:	OB2 II Telematics Device	
Exposure Category:	Population/Uncontrolled	
Sample Name:	HARMAN Spark	
Brand Name:	Harman	
Model Name:	HSA-15UA-BR	
	Support Band	WCDMA 850MHz/1900MHz LTE Band 2/4/5/12/14,WIFI 2.4G, GPS
	Test Band	WCDMA 850MHz/1900MHz, LTE Band 2/4/5/12/14,WIFI 2.4G, GPS
	IMEI	356233110000418,356233110000459,356233110000558
	Device Class	Class B
	Multi Class	\
	Development Stage	Identical Prototype
General description:	Accessories	Power Supply:DC 12V from Car Battery
	Hotspot	2.4GHz WLAN support Hotspot mode
	Antenna type	Internal Antenna
	Operation mode	WCDMA / LTE /WIFI
	Modulation mode	UMTS(QPSK),LTE(QPSK,16QAM,64QAM), WIFI(OFDN/DSSS)
	DTM mode	Not support
	Hardware Version	V2.0
	Software Version	HSA-15UA_81_LA301_V49_R04B
	Max. SAR Value	Body: 1.427 W/Kg(Limit:1.6W/Kg, 10mm distance)

NOTE:

- The above EUT's information was declared by manufacturer. Please refer to the specifications or user's manual for more detailed description.



EUT testing configuration

Tested frequency range(s)	Transmitter Frequency Range	Receiver Frequency Range
UMTS Band II:	1850-1910 MHz	1930-1990 MHz
UMTS Band V:	824-849 MHz	869-894 MHz
LTE Band2:	1850-1910 MHz	1930-1990 MHz
LTE Band4:	1710-1755 MHz	2110-2155 MHz
LTE Band5:	824-849 MHz	869-894 MHz
LTE Band12:	698-716 MHz	728-746 MHz
LTE Band14:	758-768 MHz	788-798 MHz
WIFI(tested):	2412-2462 MHz	
Test channels(low-mid-high):	9262-9400-9538(UMTS Band II)	
	4132-4183-4233(UMTS Band V)	
	18700-18900-19100(LTE Band 2 Bandwidth 20M)	
	20050-20175-20300(LTE Band 4 Bandwidth 20M)	
	20450-20525-20600(LTE Band 5 Bandwidth 10M)	
	23060-23095-23130(LTE Band 12 Bandwidth 10M)	
	23330(LTE Band 14 Bandwidth 10M)	
1-6-11(Wi-Fi 2.4G 802.11b)		



3. SAR Summary

Highest Standalone SAR Summary

Exposure Position	Frequency Band	Scaled 1g-SAR(W/kg)	Highest Scaled 1g-SAR(W/kg)
Body & Hotspot (10mm Gap)	WCDMA Band II	1.284	1.427
	WCDMA Band V	0.832	
	LTE Band 2	1.375	
	LTE Band 4	1.427	
	LTE Band 5	0.778	
	LTE Band 12	0.652	
	LTE Band 14	1.001	
	WIFI 2.4G 802.11b	0.082	

Highest Simultaneous SAR Summary

Exposure Position	Frequency Band	Highest Scaled 1g-SAR(W/kg)
Hotspot (10mmGap)	WWAN(LTE Band 4)&WIFI 2.4G	1.509

4. Specific Absorption Rate (SAR)

4.1 Introduction

SAR is related to the rate at which energy is absorbed per unit mass in an object exposed to a radio field. The SAR distribution in a biological body is complicated and is usually carried out by experimental techniques or numerical modeling. The standard recommends limits for two tiers of groups, occupational/controlled and general population/uncontrolled, based on a person's awareness and ability to exercise control over his or her exposure. In general, occupational/controlled exposure limits are higher than the limits for general population/uncontrolled.

The SAR definition is the time derivative (rate) of the incremental energy (dW) absorbed by (dissipated in) an incremental mass (dm) contained in a volume element (dv) of a given density (ρ). The equation description is as below:

$$\text{SAR} = \frac{d}{dt} \left(\frac{dW}{dm} \right) = \frac{d}{dt} \left(\frac{dW}{\rho dv} \right)$$

SAR is expressed in units of Watts per kilogram (W/kg)

SAR measurement can be either related to the temperature elevation in tissue by

$$\text{SAR} = C \frac{\delta T}{\delta t}$$

where C is the specific heat capacity, δT is the temperature rise and δt the exposure duration, or related to the electrical field in the tissue by

$$\text{SAR} = \frac{\sigma |E|^2}{\rho}$$

where σ is the conductivity of the tissue, ρ is the mass density of the tissue and E is the rms electrical field strength.

However for evaluating SAR of low power transmitter, electrical field measurement is typically applied.



4.2 Applicable Standards and Limits

4.2.1 Applicable Standards

47CFR §2.1093	Radiofrequency Radiation Exposure Evaluation: Portable Devices
ANSI C95.1-1992	Safety Levels with Respect to Human Exposure to Radio Frequency Electromagnetic Fields, 3 kHz – 300 GHz.(IEEE Std C95.1-1991)
IEEE 1528-2013	IEEE Recommended Practice for Determining the Peak Spatial-Average Specific Absorption Rate (SAR) in the Human Head from Wireless Communications Devices: Measurement Techniques
KDB 248227 D01	v02r02 802.11 Wi-Fi SAR
KDB 447498 D01	v06 General RF Exposure Guidance
KDB 648474 D04	v01r03 Handset SAR
KDB 865664 D01	v01r04 SAR Measurement 100MHz to 6GHz
KDB 865664 D02	v01r02 SAR Exposure Reporting
KDB 941225 D01	v03r01 3G SAR Procedures
KDB 941225 D05	v02r05 SAR for LTE Devices
KDB 941225 D05A	v01r02 LTE Rel.10 KDB Inquiry Sheet
KDB 941225 D06	v02r01 Hotspot Mode

4.2.2 RF exposure Limits

Human Exposure	Uncontrolled Environment General Population
Spatial Peak SAR* (Brain/Body)	1.60 mW/g
Spatial Average SAR** (Whole Body)	0.08 mW/g
Spatial Peak SAR*** (Limbs)	4.00 mW/g

The limit applied in this test report is shown in bold letters.

Notes:

* The Spatial Peak value of the SAR averaged over any 10 grams of tissue (defined as a tissue volume in the shape of a cube) and over the appropriate averaging time

** The Spatial Average value of the SAR averaged over the whole body.

*** The Spatial Peak value of the SAR averaged over any 10 grams of tissue (defined as a tissue volume in the shape of a cube) and over the appropriate averaging time.

4.3 Phantoms

The phantom used for all tests i.e. for both system checks and device testing, was the twin-headed "SAM Phantom", manufactured by SATIMO. The SAM twin phantom is a fiberglass shell phantom with 2mm shell thickness (except the ear region, where shell thickness increases to 6mm).

System checking was performed using the flat section, whilst Head SAR tests used the left and right head profile sections. Body SAR testing also used the flat section between the head profiles.



SAM Twin Phantom

4.4 Device Holder

The device was placed in the device holder (illustrated below) that is supplied by SATIMO as an integral part of the COMOSAR test system.

The device holder is designed to cope with the different positions given in the standard. It has two scales for device rotation (with respect to the body axis) and device inclination (with respect to the line between the ear reference points). The rotation centers for both scales is the ear reference point (ERP). Thus the device needs no repositioning when changing the angles.

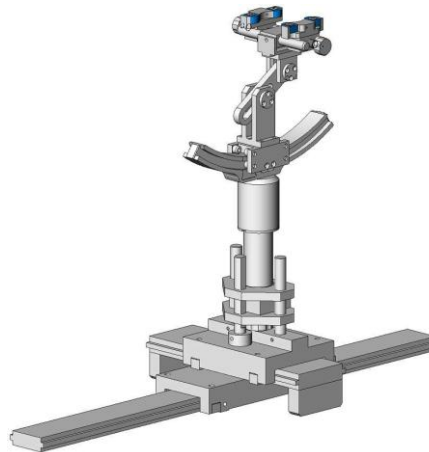

Device holder

4.5 Probe Specification



Construction	Symmetrical design with triangular core Interleaved sensors Built-in shielding against static charges PEEK enclosure material (resistant to organic solvents, e.g., DGBE)
Calibration	ISO/IEC 17025 calibration service available.
Frequency	700 MHz to 3 GHz; Linearity: ± 0.5 dB (700 MHz to 3 GHz)
Directivity	± 0.25 dB in HSL (rotation around probe axis) ± 0.5 dB in tissue material (rotation normal to probe axis)
Dynamic Range	1.5 μ W/g to 100 mW/g; Linearity: ± 0.5 dB
Dimensions	Overall length: 330 mm (Tip: 20 mm) Tip diameter: 5 mm Distance from probe tip to dipole centers: < 2.7 mm
Application	General dosimetry up to 3 GHz Dosimetry in strong gradient fields Compliance tests of mobile phones
Compatibility	COMOSAR

Isotropic E-Field Probe

The isotropic E-Field probe has been fully calibrated and assessed for isotropicity, and boundary effect within a controlled environment. Depending on the frequency for which the probe is calibrated the method utilized for calibration will change.

The E-Field probe utilizes a triangular sensor arrangement as detailed in the diagram below:

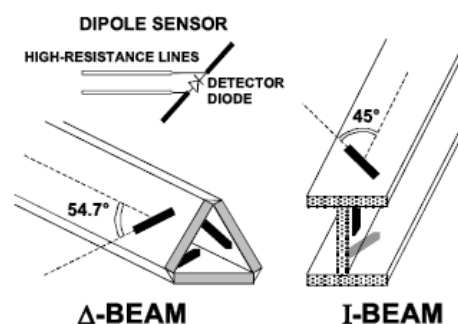

5. Tissue check and recommend Dielectric Parameters

5.1 Tissue Dielectric Parameters for Head and Body Phantoms

The head tissue dielectric parameters recommended by the IEEE SCC-34/SC-2 in P1528 have been incorporated in the following table. These head parameters are derived from planar layer models simulating the highest expected SAR for the dielectric properties and tissue thickness Power drifts in a human head. Other head and body tissue parameters that have not been specified in P1528 are derived from the tissue dielectric parameters computed from the 4-Cole-Cole equations described in Reference [12] and extrapolated according to the head parameters specified in P1528.

Table 1: Recommended Dielectric Performance of Tissue

Ingredients (% by weight)	Frequency (MHz)											
	450		835		915		1900		2450		2600	
Tissue Type	Head	Body	Head	Body	Head	Body	Head	Body	Head	Body	Head	Body
Water	38.56	51.16	41.46	52.4	41.05	56.0	54.9	40.4	62.7	73.2	55.24	64.49
Salt (NaCl)	3.95	1.49	1.45	1.4	1.35	0.76	0.18	0.5	0.5	0.04	0.5	0.024
Sugar	56.32	46.78	56.0	45.0	56.5	41.76	0.0	58.0	0.0	0.0	0.0	0.0
HEC	0.98	0.52	1.0	1.0	1.0	1.21	0.0	1.0	0.0	0.0	0.0	0.0
Bactericide	0.19	0.05	0.1	0.1	0.1	0.27	0.0	0.1	0.0	0.0	0.0	0.0
Triton x-100	0.0	0.0	0.0	0.0	0.0	0.0	0.0	0.0	36.8	0.0	44.45	32.25
DGBE	0.0	0.0	0.0	0.0	0.0	0.0	44.92	0.0	0.0	26.7	0.0	26.7
Dielectric Constant	43.42	58.0	42.54	56.1	42.0	56.8	39.9	54.0	39.2	52.5	39.0	52.5
Conductivity (s/m)	0.85	0.83	0.91	0.95	1.0	1.07	1.42	1.45	1.80	1.78	1.96	2.16

MSL/HSL750 (Body and Head liquid for 650 – 850 MHz)

Item	Head Tissue Simulation Liquid HSL750 Muscle(body)Tissue Simulation Liquid MSL750			
H2O	Water, 35 – 58%			
Sucrose	Sugar, white, refined, 40-60%			
NaCl	Sodium Chloride, 0-6%			
Hydroxyethyl-cellulose	Medium Viscosity (CAS# 9004-62-0), <0.3%			
Preventol-D7	Preservative: aqueous preparation, (CAS# 55965-84-9), containing 5-chloro-2-methyl-3(2H)-isothiazolone and 2-methyl-3(2H)-isothiazolone, 0.1-0.7%			
Frequency (MHz)	Head ϵ_r	Head σ (S/m)	Body ϵ_r	Body σ (S/m)
750	41.9	0.89	55.2	0.97

Note: The liquid of 700MHz&2600MHz typical liquid composition is provided by SATIMO.

Frequency:5200/5400/5600/5800MHz	
Ingredients	(% by weight)
Water	78
Mineral oil	11
Emulsifiers	9
Additives and Salt	2

Table 2 Recommended Tissue Dielectric Parameters

Frequency (MHz)	Head Tissue		Body Tissue	
	ϵ_r	σ (S/m)	ϵ_r	σ (S/m)
150	52.3	0.76	61.9	0.80
300	45.3	0.87	58.2	0.92
450	43.5	0.87	56.7	0.94
835	41.5	0.90	55.2	0.97
900	41.5	0.97	55.0	1.05
915	41.5	0.98	55.0	1.06
1450	40.5	1.20	54.0	1.30
1610	40.3	1.29	53.8	1.40
1800-2000	40.0	1.40	53.3	1.52
2450	39.2	1.80	52.7	1.95
3000	38.5	2.40	52.0	2.73
5800	35.3	5.27	48.2	6.00

5.2 Simulate liquid

Liquid check results:

Table 3: Dielectric Performance of Body Tissue Simulating Liquid

Temperature: 23.2 °C; Humidity: 64%;			
/	Frequency	Permittivity ϵ	Conductivity σ (S/m)
Target value	750MHz	55.5 ±5%	0.96 ±5%
Validation value (2020-05-10)	700MHz	55.53	0.94
	710MHz	55.54	0.96
	720MHz	55.52	0.93
	750MHz	55.53	0.95
Target value	835MHz	55.2 ±5%	0.97 ±5%
Validation value (2020-05-11)	825MHz	55.21	0.96
	835MHz	55.24	0.98
	845MHz	55.22	0.95
	850MHz	55.23	0.97
Target value	1800MHz	53.3 ±5%	1.52 ±5%
Validation value (2020-05-13)	1710MHz	53.31	1.51
	1730MHz	53.33	1.52
	1750MHz	53.30	1.53
	1760MHz	53.32	1.54
	1800MHz	53.34	1.55
Target value	1900MHz	53.3 ±5%	1.52 ±5%
Validation value (2020-05-14)	1850MHz	53.26	1.52
	1880MHz	53.30	1.51
	1900MHz	53.29	1.53
	1910MHz	53.27	1.50
Target value	2450MHz	52.7 ±5%	1.95 ±5%
Validation value (2020-05-16)	2410MHz	52.66	1.94
	2440MHz	52.68	1.96
	2450MHz	52.70	1.97
	2460MHz	52.72	1.95
Target value	750MHz	55.5 ±5%	0.96 ±5%
Validation value (2020-06-08)	700MHz	55.52	0.93
	710MHz	55.53	0.96
	720MHz	55.54	0.92
	750MHz	55.51	0.95

SAR System validation

Prior to the assessment, the system validation kit was used to test whether the system was operating within its specifications of $\pm 10\%$. The validation results are tabulated below. And also the corresponding SAR plot is attached as well in the SAR plots files.

The following procedure, recommended for performing validation tests using box phantoms is based on the procedures described in the IEEE standard P1528. Setup according to the setup diagram below:

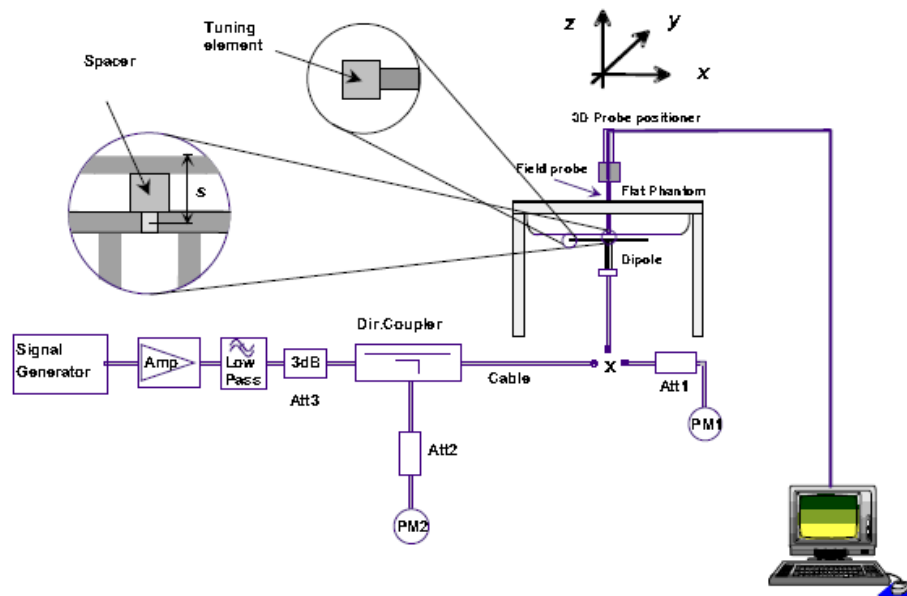

With the SG and Amp and with directional coupler in place, set up the source signal at the relevant frequency and use a power meter to measure the power at the end of the SMA cable that you intend to connect to the balanced dipole. Adjust the SG to make this, say, 0.01W (10 dBm). If this level is too high to read directly with the power meter sensor, insert a calibrated attenuator (e.g. 10 or 20 dB) and make a suitable correction to the power meter reading.

Note 1: In this method, the directional coupler is used for monitoring rather than setting the exact feed power level.

If, however, the directional coupler is used for power measurement, you should check the frequency range and power rating of the coupler and measure the coupling factor (referred to output) at the test frequency using a VNA.

Note 2: Remember that the use of a 3dB attenuator (as shown in Figure 8.1 of P1528) means that you need an RF amplifier of 2 times greater power for the same feed power. The other issue is the cable length. You might get up to 1dB of loss per meter of cable, so the cable length after the coupler needs to be quite short.

Note 3: For the validation testing done using CW signals, most power meters are suitable. However, if you are measuring the output of a modulated signal from either a signal generator or a handset, you must ensure that the power meter correctly reads the modulated signals.

The measured 1-gram averaged SAR values of the device against the phantom are provided in Tables 5 and Table 6. The humidity and ambient temperature of test facility were 64% and 23.2 °C respectively. The body phantom were full of the body tissue simulating liquid. The EUT was supplied with full-charged battery for each measurement.

The distance between the back of the EUT and the bottom of the flat phantom is 10 mm (taking into account of the IEEE 1528 and the place of the antenna).

Table 4: Body SAR system validation (1g)

Frequency	Duty cycle	Target value (W/kg)	Test value (W/kg)	
			10 mW	1W
750MHz(2020-05-10)	1:1	8.68±10%	0.0879	8.79
835MHz(2020-05-11)	1:1	9.88±10%	0.1034	10.34
1800MHz(2020-05-13)	1:1	37.68±10%	0.4067	40.67
1900MHz(2020-05-14)	1:1	38.84±10%	0.4054	40.54
2450MHz(2020-05-16)	1:1	51.42±10%	0.5374	53.74
750MHz(2020-06-08)	1:1	8.68±10%	0.0911	9.11

* Note: Target value was referring to the measured value in the calibration certificate of reference dipole.

Note: All SAR values are normalized to 1W forward power.

6. SAR measurement procedure

The SAR test against the head phantom was carried out as follow:

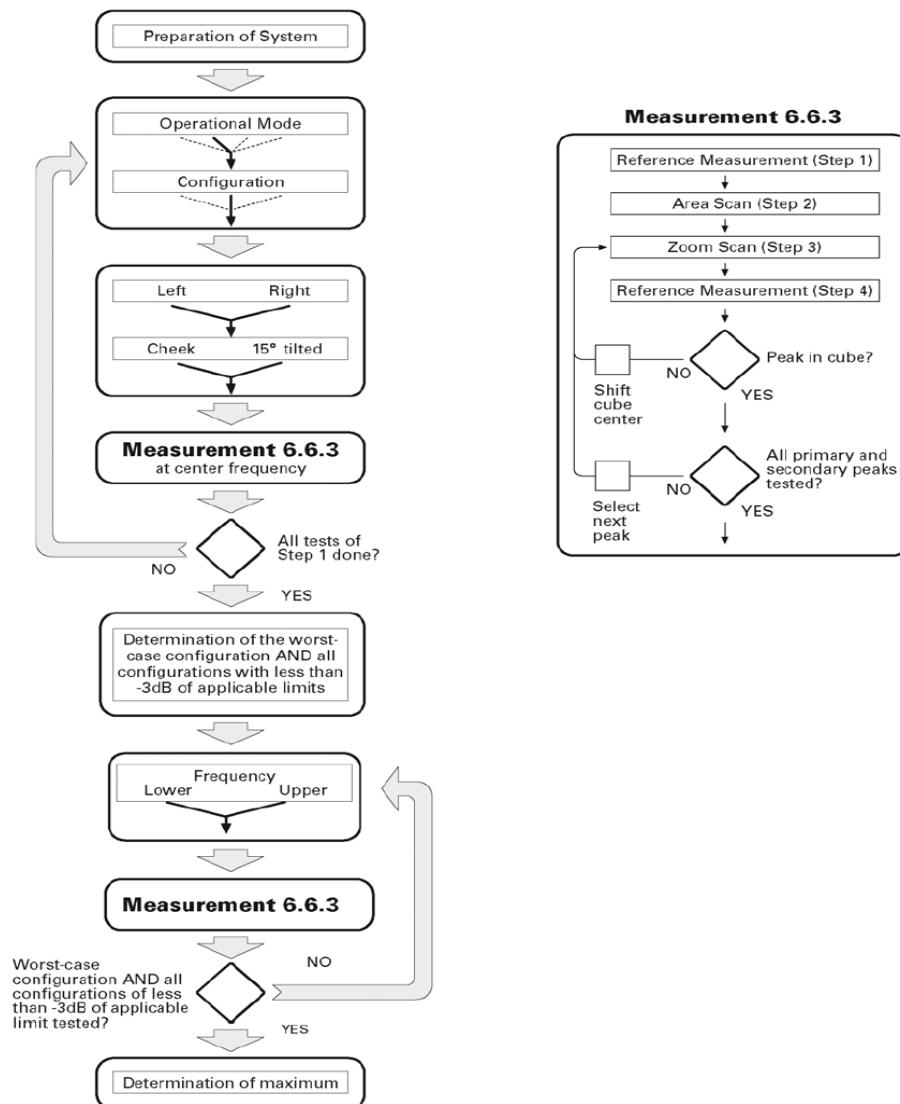

Establish a call with the maximum output power with a base station simulator, the connection between the EUT and the base station simulator is established via air interface.

After an area scan has been done at a fixed distance of 2mm from the surface of the phantom on the source side, a 3D scan is set up around the location of the maximum spot SAR. First, a point within the scan area is visited by the probe and a SAR reading taken at the start of testing. At the end of testing, the probe is returned to the same point and a second reading is taken. Comparison between these start and end readings enables the power drift during measurement to be assessed.

Above is the scanning procedure flow chart and table from the IEEE p1528 standard. This is the procedure for which all compliant testing should be carried out to ensure that all variations of the device position and transmission behavior are tested.

7. Conducted RF Output Power

7.1 WCDMA Conducted output Power

UMTS1900 (Band II)		Average Power (dBm)		
		9262CH	9400CH	9538cH
WCDMA	12.2kbps RMC	21.85	21.92	21.78
HSDPA	Subtest 1	21.74	21.83	21.66
	Subtest 2	21.65	21.74	21.57
	Subtest 3	21.53	21.61	21.48
	Subtest 4	21.45	21.50	21.36
HSUPA	Subtest 1	21.38	21.42	21.25
	Subtest 2	21.27	21.33	21.17
	Subtest 3	21.16	21.20	21.08
	Subtest 4	21.05	21.11	20.99
	Subtest 5	20.94	21.02	20.86
UMTS850 (Band V)		Average Power (dBm)		
		4132CH	4183CH	4233CH
WCDMA	12.2kbps RMC	22.16	22.33	22.21
HSDPA	Subtest 1	22.07	22.24	22.14
	Subtest 2	21.95	22.15	22.06
	Subtest 3	21.84	22.07	21.94
	Subtest 4	21.73	21.93	21.88
HSUPA	Subtest 1	21.67	21.85	21.74
	Subtest 2	21.56	21.74	21.67
	Subtest 3	21.44	21.66	21.56
	Subtest 4	21.38	21.53	21.43
	Subtest 5	21.23	21.45	21.34

Note:

1. WCDMA SAR was tested under RMC 12.2kbps with HSPA Inactive per KDB Publication 941225 D01v03r01. HSPA SAR was not required since the average output power of the HSPA subtests was not more than 0.25dB higher than the RMC level and SAR was less than 1.2W/kg.
2. It is expected by the manufacturer that MPR for some HSPA subtests may be up to 2dB more than specified by 3GPP, but also as low as 0dB according to the chipset implementation in this model

7.2 LTE Conducted peak output Power

LTE Test Configurations

The CMW500 Wide Band Radio Communication Tester was used for LTE output power measurements and SAR testing. Closed loop power control was used so the UE transmits with maximum output power during SAR testing. SAR test were performed with the same number of RB and RB offsets transmitting on all frames.

1) Spectrum Plots for RB configurations

A properly configured base station simulator was used for LTE output power measurements and SAR testing. Therefore, spectrum plots for RB configurations were not required to be included in this report.

2) MPR

When MPR is implemented permanently within the UE, regardless of network requirements, only those RB configurations allowed by 3GPP for the channel bandwidth and modulation combinations may be tested with MPR active. Configurations with RB allocations less than the RB thresholds required by 3GPP must be tested without MPR.

The allowed Maximum Power Reduction(MPR) for the maximum output power due to higher order modulation and transmit bandwidth configuration (resource blocks) is specified in Table 6.2.3-1 of the 3GPP TS36.101:

Table 6.2.3-1: Maximum Power Reduction (MPR) for Power Class 3

Modulation	Channel bandwidth / Transmission bandwidth configuration [RB]						MPR (dB)
	1.4 MHz	3.0 MHz	5 MHz	10 MHz	15 MHz	20 MHz	
QPSK	> 5	> 4	> 8	> 12	> 16	> 18	≤ 1
16 QAM	≤ 5	≤ 4	≤ 8	≤ 12	≤ 16	≤ 18	≤ 1
16 QAM	> 5	> 4	> 8	> 12	> 16	> 18	≤ 2

3)A-MPR LTE procedures for SAR testing

A-MPR(Additional MPR) has been disabled for all SAR tests by using Network Signaling Value of “NS_01” on the base station simulator.

4)LTE procedures for SAR testing

A) Largest channel bandwidth standalone SAR test

requirements i) QPSK with 1 RB allocation

Start with the largest channel bandwidth and measure SAR for QPSK with 1 RB allocation, using the RB offset and required test channel combination with the highest maximum output power for RB offsets at the upper edge, middle and lower edge of each required test channel. When the reported SAR is $\leq 0.8\text{W/kg}$, testing of the remaining RB offset configurations and required test channels is not required for 1RB allocation; otherwise, SAR is required for the remaining required test channels and only for the RB offset configuration with the highest output power for that channel. When the reported SAR of a required test channel is $> 1.45\text{W/kg}$, SAR is required for all three RB offset configurations for that required test channel.



The priority Main Antenna:

1. LTE Band 2 Conducted Power Test Verdict:

LTE FDD Band 2				Conducted Power(dBm)			Tune up
Bandwidth	Modulation	RB size	RB offset	Channel/Frequency			
				18607/1850.7	18900/1880	19193/1909.3	
1.4MHz	QPSK	1	0	21.21	21.46	21.33	21.0±1.0
		1	3	21.17	21.34	21.24	
		1	5	21.24	21.22	21.15	
		3	0	20.33	20.49	20.41	20.0±1.0
		3	2	20.27	20.39	20.23	
		3	3	20.27	20.36	20.26	
	6	0	20.13	20.24	20.27	20.0±1.0	
	16QAM	1	0	20.17	20.43	20.28	20.0±1.0
		1	3	20.13	20.31	20.19	
		1	5	20.2	20.19	20.1	
		3	0	19.29	19.46	19.36	19.0±1.0
		3	2	19.23	19.36	19.18	
		3	3	19.23	19.33	19.21	
	6	0	19.09	19.21	19.22	19.0±1.0	
Bandwidth	Modulation	RB size	RB offset	Channel/Frequency			Tune up
3MHz	QPSK	1	0	21.26	21.49	21.37	21.0±1.0
		1	7	21.22	21.37	21.28	
		1	14	21.29	21.25	21.19	
		8	0	20.38	20.52	20.45	20.0±1.0
		8	4	20.32	20.42	20.27	
		8	7	20.32	20.39	20.3	
		15	0	20.18	20.27	20.31	20.0±1.0
	16QAM	1	0	20.22	20.46	20.32	20.0±1.0
		1	7	20.18	20.34	20.23	
		1	14	20.25	20.22	20.14	
		8	0	19.34	19.49	19.4	19.0±1.0
		8	4	19.28	19.39	19.22	
		8	7	19.28	19.36	19.25	
		15	0	19.14	19.24	19.26	19.0±1.0



LTE FDD Band 2				Conducted Power(dBm)			Tune up
Bandwidth	Modulation	RB size	RB offset	Channel/Frequency			
				18625/1852.5	18900/1880	19175/1907.5	
5MHz	QPSK	1	0	21.31	21.52	21.41	21.0±1.0
		1	13	21.27	21.4	21.32	
		1	24	21.34	21.28	21.23	
		12	0	20.43	20.55	20.49	20.0±1.0
		12	6	20.37	20.45	20.31	
		12	13	20.37	20.42	20.34	
	25	0	20.23	20.3	20.35	20.0±1.0	
	16QAM	1	0	20.27	20.49	20.36	20.0±1.0
		1	13	20.23	20.37	20.27	
		1	24	20.3	20.25	20.18	
		12	0	19.39	19.52	19.44	19.0±1.0
		12	6	19.33	19.42	19.26	
		12	13	19.33	19.39	19.29	
		25	0	19.19	19.27	19.3	19.0±1.0
Bandwidth	Modulation	RB size	RB offset	Channel/Frequency			Tune up
10MHz	QPSK	1	0	21.36	21.55	21.45	21.0±1.0
		1	25	21.32	21.43	21.36	
		1	49	21.39	21.31	21.27	
		25	0	20.48	20.58	20.53	20.0±1.0
		25	13	20.42	20.48	20.35	
		25	25	20.42	20.45	20.38	
		50	0	20.28	20.33	20.39	20.0±1.0
	16QAM	1	0	20.32	20.52	20.4	20.0±1.0
		1	25	20.28	20.4	20.31	
		1	49	20.35	20.28	20.22	
		25	0	19.44	19.55	19.48	19.0±1.0
		25	13	19.38	19.45	19.3	
		25	25	19.38	19.42	19.33	
		50	0	19.24	19.3	19.34	19.0±1.0



LTE FDD Band 2				Conducted Power(dBm)			Tune up
Bandwidth	Modulation	RB size	RB offset	Channel/Frequency			
				18675/1857.5	18900/1880	19125/1902.5	
15MHz	QPSK	1	0	21.4	21.58	21.5	21.0±1.0
		1	38	21.36	21.46	21.41	
		1	74	21.43	21.34	21.32	
		36	0	20.52	20.61	20.58	20.0±1.0
		36	18	20.46	20.51	20.4	
		36	39	20.46	20.48	20.43	
		75	0	20.32	20.36	20.44	20.0±1.0
	16QAM	1	0	20.36	20.55	20.45	20.0±1.0
		1	38	20.32	20.43	20.36	
		1	74	20.39	20.31	20.27	
		36	0	19.48	19.58	19.53	19.0±1.0
		36	18	19.42	19.48	19.35	
		36	39	19.42	19.45	19.38	
		75	0	19.28	19.33	19.39	19.0±1.0
Bandwidth	Modulation	RB size	RB offset	Channel/Frequency			Tune up
20MHz	QPSK	1	0	21.43	21.6	21.54	21.0±1.0
		1	50	21.25	21.38	21.24	
		1	99	21.47	21.23	21.34	
		50	0	20.55	20.63	20.62	20.0±1.0
		50	25	20.45	20.44	20.36	
		50	50	20.54	20.54	20.35	
		100	0	20.54	20.38	20.44	20.0±1.0
	16QAM	1	0	20.39	20.57	20.49	20.0±1.0
		1	50	20.21	20.17	20.5	
		1	99	20.5	20.4	20.2	
		50	0	19.51	19.6	19.57	19.0±1.0
		50	25	19.44	19.42	19.48	
		50	50	19.42	19.43	19.46	
		100	0	19.48	19.32	19.37	19.0±1.0



2. LTE Band 4 Conducted Power Test Verdict:

LTE FDD Band 4				Conducted Power(dBm)			
Bandwidth	Modulation	RB size	RB offset	Channel/Frequency			Tune up
				19957/1710.7	20175/1732.5	20393/1754.3	
1.4MHz	QPSK	1	0	20.54	20.87	20.68	20.0±1.0
		1	3	20.46	20.57	20.47	
		1	5	20.54	20.52	20.54	
		3	0	19.66	19.82	19.71	19.0±1.0
		3	2	19.41	19.51	19.51	
		3	3	19.67	19.42	19.46	
	6	0	19.58	19.6	19.42	19.0±1.0	
	16QAM	1	0	19.5	19.85	19.63	19.5±1.0
		1	3	19.42	19.55	19.42	
		1	5	19.5	19.5	19.49	
		3	0	18.62	18.8	18.66	18.5±1.0
		3	2	18.37	18.49	18.46	
		3	3	18.63	18.4	18.41	
		6	0	18.54	18.58	18.37	18.5±1.0
Bandwidth	Modulation	RB size	RB offset	Channel/Frequency			Tune up
				19965/1711.5	20175/1732.5	20385/1753.5	
3MHz	QPSK	1	0	20.57	20.89	20.72	20.0±1.0
		1	7	20.49	20.59	20.51	
		1	14	20.57	20.54	20.58	
		8	0	19.69	19.84	19.75	19.0±1.0
		8	4	19.44	19.53	19.55	
		8	7	19.7	19.44	19.5	
		15	0	19.61	19.62	19.46	19.0±1.0
	16QAM	1	0	19.53	19.87	19.67	19.5±1.0
		1	7	19.45	19.57	19.46	
		1	14	19.53	19.52	19.53	
		8	0	18.65	18.82	18.7	18.5±1.0
		8	4	18.4	18.51	18.5	
		8	7	18.66	18.42	18.45	
		15	0	18.57	18.6	18.41	18.5±1.0



LTE FDD Band 4				Conducted Power(dBm)			
Bandwidth	Modulation	RB size	RB offset	Channel/Frequency			Tune up
				19975/1712.5	20175/1732.5	20375/1752.5	
5MHz	QPSK	1	0	20.6	20.91	20.76	20.0±1.0
		1	13	20.52	20.61	20.55	
		1	24	20.6	20.56	20.62	
		12	0	19.72	19.86	19.79	19.0±1.0
		12	6	19.47	19.55	19.59	
		12	13	19.73	19.46	19.54	
		25	0	19.64	19.64	19.5	19.0±1.0
	16QAM	1	0	19.56	19.89	19.71	19.5±1.0
		1	13	19.48	19.59	19.5	
		1	24	19.56	19.54	19.57	
		12	0	18.68	18.84	18.74	18.5±1.0
		12	6	18.43	18.53	18.54	
		12	13	18.69	18.44	18.49	
		25	0	18.6	18.62	18.45	18.5±1.0
Bandwidth	Modulation	RB size	RB offset	Channel/Frequency			Tune up
				20000/1715	20175/1732.5	20350/1750	
10MHz	QPSK	1	0	20.63	20.93	20.8	20.0±1.0
		1	25	20.55	20.63	20.59	
		1	49	20.63	20.58	20.66	
		25	0	19.75	19.88	19.83	19.0±1.0
		25	13	19.5	19.57	19.63	
		25	25	19.76	19.48	19.58	
		50	0	19.67	19.66	19.54	19.0±1.0
	16QAM	1	0	19.59	19.91	19.75	19.5±1.0
		1	25	19.51	19.61	19.54	
		1	49	19.59	19.56	19.61	
		25	0	18.71	18.86	18.78	18.5±1.0
		25	13	18.46	18.55	18.58	
		25	25	18.72	18.46	18.53	
		50	0	18.63	18.64	18.49	18.5±1.0



LTE FDD Band 4				Conducted Power(dBm)			
Bandwidth	Modulation	RB size	RB offset	Channel/Frequency			Tune up
				20025/1717.5	20175/1732.5	20325/1747.5	
15MHz	QPSK	1	0	20.67	20.95	20.85	20.0±1.0
		1	38	20.59	20.65	20.64	
		1	74	20.67	20.6	20.71	
		36	0	19.79	19.9	19.88	19.0±1.0
		36	18	19.54	19.59	19.68	
		36	39	19.8	19.5	19.63	
		75	0	19.71	19.68	19.59	19.0±1.0
	16QAM	1	0	19.63	19.93	19.8	19.5±1.0
		1	38	19.55	19.63	19.59	
		1	74	19.63	19.58	19.66	
		36	0	18.75	18.88	18.83	18.5±1.0
		36	18	18.5	18.57	18.63	
		36	39	18.76	18.48	18.58	
		75	0	18.67	18.66	18.54	18.5±1.0
Bandwidth	Modulation	RB size	RB offset	Channel/Frequency			Tune up
				20050/1720	20175/1732.5	20300/1745	
20MHz	QPSK	1	0	20.72	20.98	20.89	20.0±1.0
		1	50	20.64	20.68	20.68	
		1	99	20.72	20.63	20.75	
		50	0	19.84	19.93	19.92	19.0±1.0
		50	25	19.59	19.62	19.72	
		50	50	19.85	19.53	19.67	
		100	0	19.76	19.71	19.63	19.0±1.0
	16QAM	1	0	19.68	19.96	19.84	19.5±1.0
		1	50	19.6	19.66	19.63	
		1	99	19.68	19.61	19.7	
		50	0	18.8	18.91	18.87	18.5±1.0
		50	25	18.55	18.6	18.67	
		50	50	18.81	18.51	18.62	
		100	0	18.72	18.69	18.58	18.5±1.0



3. LTE Band 5 Conducted Power Test Verdict:

LTE FDD Band 5				Conducted Power(dBm)			Tune up
Bandwidth	Modulation	RB size	RB offset	Channel/Frequency			
				20407/824.7	20525/836.5	20643/848.3	
1.4MHz	QPSK	1	0	20.97	21.03	20.79	20.5±1.0
		1	3	20.81	20.99	20.67	
		1	5	20.7	21	20.72	
		3	0	20.25	20.28	20.31	19.5±1.0
		3	2	20.23	20.23	20.26	
		3	3	20.14	20.24	20.2	
		6	0	20.06	20.16	20.15	19.5±1.0
	16QAM	1	0	19.92	20	19.77	19.5±1.0
		1	3	19.76	19.96	19.65	
		1	5	19.65	19.97	19.7	
		3	0	19.2	19.25	19.29	19.0±1.0
		3	2	19.18	19.2	19.24	
		3	3	19.09	19.21	19.18	
		6	0	19.01	19.13	19.13	19.0±1.0
Bandwidth	Modulation	RB size	RB offset	Channel/Frequency			Tune up
3MHz	QPSK	1	0	21.02	21.06	20.83	20.5±1.0
		1	7	20.86	21.02	20.71	
		1	14	20.75	21.03	20.76	
		8	0	20.3	20.31	20.35	19.5±1.0
		8	4	20.28	20.26	20.3	
		8	7	20.19	20.27	20.24	
		15	0	20.11	20.19	20.19	19.5±1.0
	16QAM	1	0	19.97	20.03	19.81	19.5±1.0
		1	7	19.81	19.99	19.69	
		1	14	19.7	20	19.74	
		8	0	19.25	19.28	19.33	19.0±1.0
		8	4	19.23	19.23	19.28	
		8	7	19.14	19.24	19.22	
		15	0	19.06	19.16	19.17	19.0±1.0



LTE FDD Band 5				Conducted Power(dBm)			
Bandwidth	Modulation	RB size	RB offset	Channel/Frequency			Tune up
				20425/826.5	20525/836.5	20625/846.5	
5MHz	QPSK	1	0	21.07	21.09	20.87	20.5±1.0
		1	13	20.91	21.05	20.75	
		1	24	20.8	21.06	20.8	
		12	0	20.35	20.34	20.39	19.5±1.0
		12	6	20.33	20.29	20.34	
		12	13	20.24	20.3	20.28	
		25	0	20.16	20.22	20.23	19.5±1.0
	16QAM	1	0	20.02	20.06	19.85	19.5±1.0
		1	13	19.86	20.02	19.73	
		1	24	19.75	20.03	19.78	
		12	0	19.3	19.31	19.37	19.0±1.0
		12	6	19.28	19.26	19.32	
		12	13	19.19	19.27	19.26	
		25	0	19.11	19.19	19.21	19.0±1.0
Bandwidth	Modulation	RB size	RB offset	Channel/Frequency			Tune up
				20450/829	20525/836.5	20600/844	
10MHz	QPSK	1	0	21.1	21.11	20.91	20.5±1.0
		1	25	20.94	21.07	20.79	
		1	49	20.83	21.08	20.84	
		25	0	20.38	20.36	20.43	19.5±1.0
		25	13	20.36	20.31	20.38	
		25	25	20.27	20.32	20.32	
		50	0	20.19	20.24	20.27	19.5±1.0
	16QAM	1	0	20.05	20.08	19.89	19.5±1.0
		1	25	19.89	20.04	19.77	
		1	49	19.78	20.05	19.82	
		25	0	19.33	19.33	19.41	19.0±1.0
		25	13	19.31	19.28	19.36	
		25	25	19.22	19.29	19.3	
		50	0	19.14	19.21	19.25	19.0±1.0



4. LTE Band 12 Conducted Power Test Verdict:

LTE FDD Band 12				Conducted Power(dBm)			Tune up
Bandwidth	Modulation	RB size	RB offset	Channel/Frequency			
				23017/699.7	23095/707.5	23173/715.3	
1.4MHz	QPSK	1	0	21.24	21.4	21.29	20.5±1.0
		1	3	21.1	21.34	21.28	
		1	5	21.17	21.17	21.15	
		3	0	20.24	20.33	20.08	19.5±1.0
		3	2	20.2	20.29	20.06	
		3	3	20.13	20.22	20.05	
		6	0	20.06	20.1	20.03	19.5±1.0
	16QAM	1	0	19.82	19.95	19.69	19.5±1.0
		1	3	19.66	19.91	19.57	
		1	5	19.55	19.92	19.62	
		3	0	19.1	19.2	19.21	19.0±1.0
		3	2	19.08	19.15	19.16	
		3	3	18.99	19.16	19.1	
		6	0	18.91	19.08	19.05	19.0±1.0
Bandwidth	Modulation	RB size	RB offset	Channel/Frequency			Tune up
3MHz	QPSK	1	0	21.28	21.43	21.33	20.5±1.0
		1	7	21.14	21.37	21.32	
		1	14	21.21	21.2	21.19	
		8	0	20.28	20.36	20.12	19.5±1.0
		8	4	20.24	20.32	20.1	
		8	7	20.17	20.25	20.09	
		15	0	20.1	20.13	20.07	19.5±1.0
	16QAM	1	0	19.86	19.98	19.73	19.5±1.0
		1	7	19.7	19.94	19.61	
		1	14	19.59	19.95	19.66	
		8	0	19.14	19.23	19.25	19.0±1.0
		8	4	19.12	19.18	19.2	
		8	7	19.03	19.19	19.14	
		15	0	18.95	19.11	19.09	19.0±1.0



LTE FDD Band 12				Conducted Power(dBm)			Tune up
Bandwidth	Modulation	RB size	RB offset	Channel/Frequency			
				23035/701.5	23095/707.5	23155/713.5	
5MHz	QPSK	1	0	21.34	21.45	21.37	20.5±1.0
		1	13	21.2	21.39	21.36	
		1	24	21.27	21.22	21.23	
		12	0	20.34	20.38	20.16	19.5±1.0
		12	6	20.3	20.34	20.14	
		12	13	20.23	20.27	20.13	
		25	0	20.16	20.15	20.11	19.5±1.0
	16QAM	1	0	19.92	20	19.77	19.5±1.0
		1	13	19.76	19.96	19.65	
		1	24	19.65	19.97	19.7	
		12	0	19.2	19.25	19.29	19.0±1.0
		12	6	19.18	19.2	19.24	
		12	13	19.09	19.21	19.18	
		25	0	19.01	19.13	19.13	19.0±1.0
Bandwidth	Modulation	RB size	RB offset	Channel/Frequency			Tune up
10MHz	QPSK	1	0	21.39	21.48	21.41	20.5±1.0
		1	25	21.25	21.42	21.40	
		1	49	21.32	21.25	21.27	
		25	0	20.39	20.41	20.20	19.5±1.0
		25	13	20.35	20.37	20.18	
		25	25	20.28	20.30	20.17	
		50	0	20.21	20.18	20.15	19.5±1.0
	16QAM	1	0	19.97	20.03	19.81	19.5±1.0
		1	25	19.81	19.99	19.69	
		1	49	19.7	20	19.74	
		25	0	19.25	19.28	19.33	19.0±1.0
		25	13	19.23	19.23	19.28	
		25	25	19.14	19.24	19.22	
		50	0	19.06	19.16	19.17	19.0±1.0



LTE FDD Band 14				Conducted Power(dBm)			
Bandwidth	Modulation	RB size	RB offset	Channel/Frequency			Tune up
				23305/790.5	23330/793	23355/795.5	
5MHz	QPSK	1	0	20.48	20.6	20.55	20.0±1.0
		1	13	20.37	20.47	20.41	
		1	24	20.33	20.48	20.4	
		12	0	19.92	20.05	20.02	19.5±1.0
		12	6	19.6	19.75	19.67	
		12	13	19.64	19.78	19.74	
		25	0	19.75	19.92	19.85	
	16QAM	1	0	19.76	19.97	19.91	19.0±1.0
		1	13	19.65	19.82	19.76	
		1	24	19.75	19.94	19.88	
		12	0	19.45	19.62	19.56	19.0±1.0
		12	6	19.28	19.55	19.43	
		12	13	19.2	19.43	19.32	
		25	0	19.06	19.31	19.2	
Bandwidth	Modulation	RB size	RB offset	Channel/Frequency			Tune up
				23330/793			
10MHz	QPSK	1	0	20.64			20.0±1.0
		1	25	20.53			
		1	49	20.49			
		25	0	20.28			19.5±1.0
		25	13	20.16			
		25	25	20.2			
		50	0	19.91			
	16QAM	1	0	20.12			19.5±1.0
		1	25	19.91			
		1	49	19.77			
		25	0	19.74			19.0±1.0
		25	13	19.54			
		25	25	19.46			
		50	0	19.32			

7.4 WIFI Conducted Power

WLAN 2.4GHz Band Conducted Power

Channel/Freq.(MHz)	Maximum Conducted Out Power (dBm)		
	802.11b	802.11g	802.11n(HT20)
1(2412)	16.24	14.87	11.83
6(2437)	16.26	15.10	12.48
11(2462)	16.15	15.05	12.21

Channel/Freq.(MHz)	Maximum Conducted Out Power (dBm)
	802.11n(HT40)
3(2422)	12.52
6(2437)	12.40
9(2452)	12.09

Note:

1. Per KDB248227 D01 v02r02, choose the highest output power channel to test SAR and determine further SAR exclusion
2. For each frequency band, testing at higher data rates and higher order modulations is not required when the maximum average output power for each of these configurations is less than 1/4dB higher than those measured at lowest data rate
3. Per KDB248227 D01 v02r02, 802.11g /11n-HT20/11n-HT40 is not required. . When the highest reported SAR for DSSS is adjusted by the ratio of OFDM to DSSS specified maximum output power and the adjusted SAR is $\leq 1.2\text{W/Kg}$. Thus the SAR can be excluded.

Antenna Location:

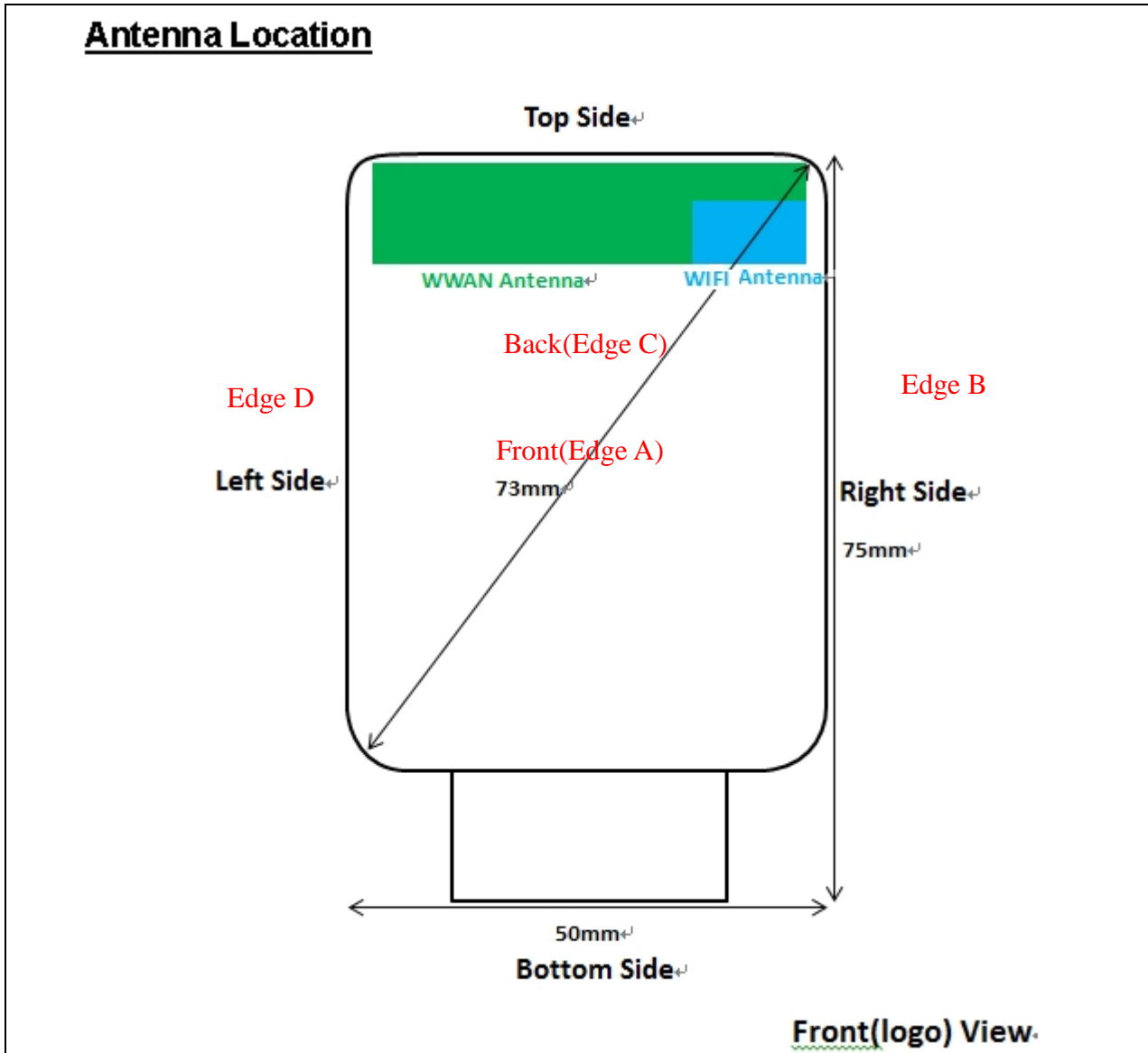

The Body SAR measurement positions of each band are as below:

Antenna	Top Side	Edge A	Edge B	Edge C	Edge D
WWAN Antenna Body-worn	Yes	Yes	No	No	No
WWAN Antenna hotspot	Yes	Yes	Yes	Yes	Yes
WIFI Antenna Body-worn	Yes	No	No	No	No
WIFI 2.4G Antenna hotspot	Yes	Yes	Yes	Yes	No

Note: According to KDB 941225 D06 v02r01, when antenna-to-edge>2.5cm, SAR is not required.

8. Scaling Factor calculation

Operation Mode	Channel /Frequency	Output Power(dBm)	Tune up Power in tolerance (dBm)	Max. Tune up(dBm)	Scaling Factor
WCDMA850	4132/826.4	22.16	21.5 ±1.0	22.50	1.081
	4183/836.6	22.33	21.5 ±1.0	22.50	1.040
	4233/846.6	22.21	21.5 ±1.0	22.50	1.069
WCDMA1900	9262/1852.4	21.85	21.0 ±1.0	22.00	1.035
	9400/1880.0	21.92	21.0 ±1.0	22.00	1.019
	9538/1907.6	21.78	21.0 ±1.0	22.00	1.052
LTE B2 20MHz 1RB#0	18700/1860	21.43	21.0 ±1.0	22.00	1.140
	18900/1880	21.60	21.0 ±1.0	22.00	1.096
	19100/1900	21.54	21.0 ±1.0	22.00	1.112
LTE B2 20MHz 50RB#0	18700/1860	20.55	20.0 ±1.0	21.00	1.109
	18900/1880	20.63	20.0 ±1.0	21.00	1.089
	19100/1900	20.62	20.0 ±1.0	21.00	1.091
LTE B4 20MHz 1RB#0	20050/1720	20.72	20.0 ±1.0	21.00	1.067
	20175/1732.5	20.98	20.0 ±1.0	21.00	1.005
	20300/1745	20.89	20.0 ±1.0	21.00	1.026
LTE B4 20MHz 50RB#0	20050/1720	19.84	19.0 ±1.0	20.00	1.038
	20175/1732.5	19.93	19.0 ±1.0	20.00	1.016
	20300/1745	19.92	19.0 ±1.0	20.00	1.019
LTE B5 10MHz 1RB#0	20450/829	21.10	20.5 ±1.0	21.50	1.096
	20525/836.5	21.11	20.5 ±1.0	21.50	1.094
	20600/844	20.91	20.5 ±1.0	21.50	1.146
LTE B5 10MHz 25RB#0	20450/829	20.38	19.5 ±1.0	20.50	1.028
	20525/836.5	20.36	19.5 ±1.0	20.50	1.033
	20600/844	20.43	19.5 ±1.0	20.50	1.016
LTE B12 10MHz 1RB#0	23060/704	21.39	20.5 ±1.0	21.50	1.026
	23095/707.5	21.48	20.5 ±1.0	21.50	1.005
	23130/711	21.41	20.5 ±1.0	21.50	1.021
LTE B12 10MHz 25RB#0	23060/704	20.39	19.5 ±1.0	20.50	1.026
	23095/707.5	20.41	19.5 ±1.0	20.50	1.021
	23130/711	20.20	19.5 ±1.0	20.50	1.072
LTE B14 10MHz 1RB#0	23330/793	20.64	20.0 ±1.0	21.00	1.086
LTE B14 10MHz 50RB#0	23330/793	20.28	19.5 ±1.0	20.50	1.052
WIFI 2.4G 802.11b	1/2412	16.24	15.5 ±1.0	16.50	1.062
	6/2437	16.26	15.5 ±1.0	16.50	1.057
	11/2462	16.15	15.5 ±1.0	16.50	1.084

Note: for LTE power tolerance, only QPSK modulation mode was provide here.

9. Test Results

Results overview of WCDMA850

Body&Hotspot(10mm)	Channel /Frequency	Mode	SAR Value (W/kg)1-g	Power drift(%)	Scaled Factor	Scaled SAR (W/Kg)1-g	SAR Plot.
Edge C	4132/826.4	RMC	0.767	2.04	1.081	0.829	/
Edge C	4183/836.6	RMC	0.800	-1.14	1.040	0.832	Yes
Edge C	4233/846.6	RMC	0.775	4.81	1.069	0.829	/
Edge C (Repeated)	4132/826.4	RMC	0.742	-2.61	1.081	0.802	/
	4183/836.6	RMC	0.782	-1.54	1.040	0.813	/
	4233/846.6	RMC	0.759	-2.08	1.069	0.811	/
Top Side	4183/836.6	RMC	0.225	-0.08	1.040	0.234	/
Edge A	4183/836.6	RMC	0.426	-2.67	1.040	0.443	/
Edge B	4183/836.6	RMC	0.495	4.19	1.040	0.515	/
Edge D	4183/836.6	RMC	0.567	2.32	1.040	0.590	/

**Results overview of WCDMA1900**

Body&Hotspot(10mm)	Channel /Frequency	Mode	SAR Value (W/kg)1-g	Power drift(%)	Scaled Factor	Scaled SAR (W/Kg)1-g	SAR Plot.
Edge D	9262/1852.4	RMC	1.228	-1.06	1.035	1.271	/
Edge D	9400/1880.0	RMC	1.261	0.20	1.019	1.284	Yes
Edge D	9538/1907.6	RMC	1.203	1.13	1.052	1.266	/
Edge D (Repeated)	9262/1852.4	RMC	1.202	-3.34	1.035	1.244	/
	9400/1880.0	RMC	1.224	-4.61	1.019	1.247	/
	9538/1907.6	RMC	1.182	-3.72	1.052	1.243	/
Edge D (Repeated)	9262/1852.4	RMC	1.166	-1.44	1.035	1.207	/
	9400/1880.0	RMC	1.188	-2.33	1.019	1.211	/
	9538/1907.6	RMC	1.145	-1.04	1.052	1.205	/
Edge A	9400/1880.0	RMC	0.783	2.56	1.019	0.798	/
Edge B	9400/1880.0	RMC	0.106	-2.70	1.019	0.108	/
Edge C	9262/1852.4	RMC	1.150	-3.34	1.035	1.190	/
Edge C	9400/1880.0	RMC	1.172	-2.30	1.019	1.194	/
Edge C	9538/1907.6	RMC	1.131	-4.19	1.052	1.190	/
Edge C (Repeated)	9262/1852.4	RMC	1.072	-2.41	1.035	1.110	/
	9400/1880.0	RMC	1.094	0.18	1.019	1.115	/
	9538/1907.6	RMC	1.054	-0.91	1.052	1.109	/
Top Side	9400/1880.0	RMC	0.750	-3.37	1.019	0.764	/



Results overview of FDD LTE Band 2, QPSK, 20MHz Bandwidth

Hotspot & Body-worn(10mm)	Channel /Frequency	Mode	SAR Value (W/kg)1-g	Power drift(%)	Scaled Factor	Scaled SAR (W/Kg)1-g	Limit (W/kg)
1RB#0							
Edge D	18700/1860	Data	1.203	0.57	1.140	1.372	/
Edge D	18900/1880	Data	1.254	1.96	1.096	1.375	Yes
Edge D	19100/1900	Data	1.229	-4.47	1.112	1.366	/
Edge D (Repeated)	18700/1860	Data	1.171	2.54	1.140	1.335	/
	18900/1880	Data	1.222	-2.47	1.096	1.339	/
	19100/1900	Data	1.201	-1.33	1.112	1.336	/
Edge D (Repeated)	18700/1860	Data	1.145	-2.05	1.140	1.305	
	18900/1880	Data	1.193	1.34	1.096	1.308	
	19100/1900	Data	1.162	-0.88	1.112	1.292	
Top Side	18900/1880	Data	0.697	-1.59	1.096	0.764	/
Edge A	18900/1880	Data	0.728	0.90	1.096	0.798	/
Edge B	18900/1880	Data	0.093	-1.44	1.096	0.102	/
Edge C	18700/1860	Data	1.010	-2.04	1.140	1.151	/
Edge C	18900/1880	Data	1.056	-4.92	1.096	1.158	/
Edge C	19100/1900	Data	1.133	-0.67	1.112	1.149	/
Edge C (Repeated)	18700/1860	Data	0.976	-1.39	1.140	1.113	/
	18900/1880	Data	1.019	-3.48	1.096	1.117	/
	19100/1900	Data	1.002	-2.96	1.112	1.114	/
50%RB#0							
Edge D	18700/1860	Data	1.063	-3.34	1.109	1.179	/
Edge D	18900/1880	Data	1.086	-4.04	1.089	1.183	/
Edge D	19100/1900	Data	1.075	-1.47	1.091	1.173	/
Edge D (Repeated)	18700/1860	Data	1.012	0.15	1.109	1.122	/
	18900/1880	Data	1.037	-2.11	1.089	1.129	/
	19100/1900	Data	1.028	-2.67	1.091	1.122	/
Top Side	18900/1880	Data	0.631	3.13	1.089	0.687	/
Edge A	18900/1880	Data	0.684	-2.43	1.089	0.745	/
Edge B	18900/1880	Data	0.077	0.79	1.089	0.084	/
Edge C	18700/1860	Data	0.778	-4.72	1.109	0.863	/
Edge C	18900/1880	Data	0.795	-4.09	1.089	0.866	/
Edge C	19100/1900	Data	0.786	1.67	1.091	0.858	/



Results overview of FDD LTE Band 4, QPSK, 20MHz Bandwidth

Hotspot & Body-worn(10mm)	Channel /Frequency	Mode	SAR Value (W/kg)1-g	Power drift(%)	Scaled Factor	Scaled SAR (W/Kg)1-g	Limit (W/kg)
1RB#0							
Top Side	20050/1720	Data	1.285	2.29	1.067	1.371	/
Top Side	20175/1732.5	Data	1.420	-0.90	1.005	1.427	Yes
Top Side	20300/1745	Data	1.337	2.89	1.026	1.371	/
Top Side (Repeated)	20050/1720	Data	1.243	-1.98	1.067	1.326	/
	20175/1732.5	Data	1.392	-3.31	1.005	1.399	/
	20300/1745	Data	1.289	-4.72	1.026	1.323	/
Top Side (Repeated)	20050/1720	Data	1.201	-2.05	1.067	1.281	/
	20175/1732.5	Data	1.387	1.06	1.005	1.394	/
	20300/1745	Data	1.246	0.85	1.026	1.278	/
Edge A	20175/1732.5	Data	0.587	2.12	1.005	0.590	/
Edge B	20175/1732.5	Data	0.120	-3.53	1.005	0.121	/
Edge C	20175/1732.5	Data	0.658	-4.07	1.005	0.661	/
Edge D	20175/1732.5	Data	0.625	-2.36	1.005	0.628	/
50%RB#0							
Top Side	20050/1720	Data	1.160	-1.14	1.038	1.204	/
Top Side	20175/1732.5	Data	1.193	0.29	1.016	1.212	/
Top Side	20300/1745	Data	1.177	-4.21	1.019	1.199	/
Top Side (Repeated)	20050/1720	Data	1.044	-3.61	1.038	1.084	/
	20175/1732.5	Data	1.078	-2.28	1.016	1.095	/
	20300/1745	Data	1.065	-1.27	1.019	1.085	/
Edge A	20175/1732.5	Data	0.543	-3.25	1.016	0.552	/
Edge B	20175/1732.5	Data	0.104	-1.71	1.016	0.106	/
Edge C	20175/1732.5	Data	0.621	-1.08	1.016	0.631	/
Edge D	20175/1732.5	Data	0.599	2.87	1.016	0.609	/



Results overview of FDD LTE Band 5, QPSK, 10MHz Bandwidth

Hotspot & Body-worn(10mm)	Channel /Frequency	Mode	SAR Value (W/kg)1-g	Power drift(%)	Scaled Factor	Scaled SAR (W/Kg)1-g	Limit (W/kg)
1RB#0							
Top Side	20525/836.5	Data	0.132	-0.46	1.094	0.144	/
Edge A	20525/836.5	Data	0.512	0.33	1.094	0.560	/
Edge B	20525/836.5	Data	0.345	3.41	1.094	0.377	/
Edge C	20525/836.5	Data	0.711	-1.19	1.094	0.778	Yes
Edge D	20525/836.5	Data	0.378	-3.86	1.094	0.414	/
50%RB#0							
Top Side	20525/836.5	Data	0.115	2.00	1.033	0.119	/
Edge A	20525/836.5	Data	0.483	1.66	1.033	0.499	/
Edge B	20525/836.5	Data	0.310	3.80	1.033	0.320	/
Edge C	20525/836.5	Data	0.689	-2.10	1.033	0.712	/
Edge D	20525/836.5	Data	0.345	-1.34	1.033	0.356	/

Results overview of FDD LTE Band 12, QPSK, 10MHz Bandwidth

Hotspot(10mm)	Channel /Frequency	Mode	SAR Value (W/kg)1-g	Power drift(%)	Scaled Factor	Scaled SAR (W/Kg)1-g	Limit (W/kg)
1RB#0							
Top Side	23095/707.5	Data	0.217	-1.58	1.005	0.218	/
Edge A	23095/707.5	Data	0.467	0.05	1.005	0.469	/
Edge B	23095/707.5	Data	0.480	4.05	1.005	0.482	/
Edge C	23095/707.5	Data	0.649	-0.48	1.005	0.652	Yes
Edge D	23095/707.5	Data	0.272	2.40	1.005	0.273	/
50%RB#0							
Top Side	23095/707.5	Data	0.203	4.07	1.021	0.207	/
Edge A	23095/707.5	Data	0.435	-2.81	1.021	0.444	/
Edge B	23095/707.5	Data	0.447	3.30	1.021	0.456	/
Edge C	23095/707.5	Data	0.610	-2.47	1.021	0.623	/
Edge D	23095/707.5	Data	0.246	3.34	1.021	0.251	/

**Results overview of FDD LTE Band 14, QPSK, 10MHz Bandwidth**

Hotspot(10mm)	Channel /Frequency	Mode	SAR Value (W/kg)1-g	Power drift(%)	Scaled Factor	Scaled SAR (W/Kg)1-g	Limit (W/kg)
1RB#0							
Top Side	23330/793	Data	0.228	0.89	1.086	0.248	/
Edge A	23330/793	Data	0.531	-1.23	1.086	0.577	/
Edge B	23330/793	Data	0.659	-0.93	1.086	0.716	/
Edge C	23330/793	Data	0.922	-0.97	1.086	1.001	Yes
Edge C (Repeated)	23330/793	Data	0.906	-2.97	1.086	0.984	/
Edge D	23330/793	Data	0.463	0.80	1.086	0.503	/
50%RB#0							
Top Side	23330/793	Data	0.203	1.56	1.052	0.220	/
Edge A	23330/793	Data	0.511	-3.37	1.052	0.555	/
Edge B	23330/793	Data	0.620	-2.61	1.052	0.673	/
Edge C	23330/793	Data	0.840	1.41	1.052	0.912	/
Edge C (Repeated)	23330/793	Data	0.814	-3.48	1.052	0.884	/
Edge D	23330/793	Data	0.433	-4.42	1.052	0.470	/

Results overview of WIFI2.4G 802.11b

Hotspot(10mm)	Channel /Frequency	Mode	SAR Value (W/kg)1-g	Power drift(%)	Scaled Factor	Scaled SAR (W/Kg)1-g	SAR Plot.
Back Upward	6/2437	DSSS	0.078	-2.82	1.057	0.082	Yes
Edge A	6/2437	DSSS	0.034	-4.37	1.057	0.036	/
Edge B	6/2437	DSSS	0.060	0.28	1.057	0.063	/
Edge C	6/2437	DSSS	0.023	3.82	1.057	0.024	/

Note:

Per KDB941225 D06 v02r01, When the antenna-to-edge distance is greater than 2.5cm, such position does not need to be tested. As the manufacture requirement the separation distance use 5mm for Hotspot mode.

Per KDB Publication 941225 D01v03r01. RMC 12.2kbps was as primary mode SAR, when the primary mode SAR less than 1.2W/kg, secondary SAR (HSPA) was not requires.

When the 1-g SAR for the mid-band channel or the channel with the highest output power satisfy the following conditions, testing of the other channels in the band is not required. (Per KDB 447498 D01 General RF Exposure Guidance v06)

- ≤ 0.8 W/kg, when the transmission band is ≤ 100 MHz
- ≤ 0.6 W/kg, when the transmission band is between 100 MHz and 200 MHz
- ≤ 0.4 W/kg, when the transmission band is ≥ 200 MHz

The priority (Main) and secondary(upper) antenna cannot transimit at the same time.

10. Simultaneous Transmissions Analysis

Localized Specific Absorption Rate (SAR) of this portable wireless device has been measured in all cases requested by the relevant standards cited in Clause 6 of this report. Maximum localized SAR is **below** exposure limits specified in the relevant standards.

Simultaneous SAR

No.	Transmitter Combinations	Scenario Supported or not	Supported for Mobile Hotspot or not
1	WCDMA +WIFI 2.4G	Yes	Yes
2	LTE+WIFI 2.4G	Yes	Yes

Simultaneous Tx Combination of WCDMA/LTE and WIFI (Body).

Test Position/Freq.		Top Side	Edge A	Edge B	Edge C	Edge D
Body &Hotspot MAX 1-g SAR(W/Kg) 10mm distance	WCDMA 850	0.234	0.443	0.515	0.832	0.590
	WCDMA 1900	0.764	0.798	0.108	1.194	1.284
	LTE Band2	0.764	0.798	0.102	1.158	1.375
	LTE Band4	1.427	0.590	0.121	0.661	0.628
	LTE Band5	0.144	0.560	0.377	0.778	0.414
	LTE Band12	0.218	0.469	0.482	0.652	0.273
	LTE Band14	0.248	0.577	0.716	1.001	0.503
	WIFI 2.4G	0.082	0.036	0.063	0.024	/
WIFI2.4G Simultaneous \sum 1-g SAR(W/Kg)		1.509	0.834	0.779	1.218	/

SAR to Peak Location Separation Ratio (SPLSR)

As the Sum of the SAR is not greater than 1.6 W/kg SPLSR assessment is not required

11. Measurement Uncertainty

No.	Uncertainty Component	Type	Uncertainty Value (%)	Probability Distribution	k	ci	Standard Uncertainty (%) $u_i(\%)$	Degree of freedom ν_{eff} or ν_i
Measurement System								
1	– Probe Calibration	B	5.8	N	1	1	5.8	∞
2	– Axial isotropy	B	3.5	R	$\sqrt{3}$	0.5	1.43	∞
3	– Hemispherical Isotropy	B	5.9	R	$\sqrt{3}$	0.5	2.41	∞
4	– Boundary Effect	B	1	R	$\sqrt{3}$	1	0.58	∞
5	– Linearity	B	4.7	R	$\sqrt{3}$	1	2.71	∞
6	– System Detection Limits	B	1.0	R	$\sqrt{3}$	1	0.58	∞
7	Modulation response	B	3	N	1	1	3.00	
8	– Readout Electronics	B	0.5	N	1	1	0.50	∞
9	– Response Time	B	1.4	R	$\sqrt{3}$	1	0.81	∞
10	– Integration Time	B	3.0	R	$\sqrt{3}$	1	1.73	∞
11	– RF Ambient Conditions	B	3.0	R	$\sqrt{3}$	1	1.73	∞
12	– Probe Position Mechanical tolerance	B	1.4	R	$\sqrt{3}$	1	0.81	∞
13	– Probe Position with respect to Phantom Shell	B	1.4	R	$\sqrt{3}$	1	0.81	∞
14	– Extrapolation, Interpolation and Integration Algorithms for Max. SAR evaluation	B	2.3	R	$\sqrt{3}$	1	1.33	∞
Uncertainties of the DUT								

15	– Position of the DUT	A	2.6	N	$\sqrt{3}$	1	2.6	5
16	– Holder of the DUT	A	3	N	$\sqrt{3}$	1	3.0	5
17	– Output Power Variation –SAR drift measurement	B	5.0	R	$\sqrt{3}$	1	2.89	∞
Phantom and Tissue Parameters								
18	– Phantom Uncertainty(shape and thickness tolerances)	B	4	R	$\sqrt{3}$	1	2.31	∞
19	Uncertainty in SAR correction for deviation(in permittivity and conductivity)	B	2	N	1	1	2.00	
20	– Liquid Conductivity Target –tolerance	B	2.5	R	$\sqrt{3}$	0.6	1.95	∞
21	– Liquid Conductivity –measurement Uncertainty)	B	4	N	$\sqrt{3}$	1	0.92	9
22	– Liquid Permittivity Target tolerance	B	2.5	R	$\sqrt{3}$	0.6	1.95	∞
23	– Liquid Permittivity –measurement uncertainty	B	5	N	$\sqrt{3}$	1	1.15	∞
Combined Standard Uncertainty				RSS			10.63	
Expanded uncertainty (Confidence interval of 95 %)				K=2			21.26	

System Check Uncertainty

No.	Uncertainty Component	Type	Uncertainty Value (%)	Probability Distribution	k	ci	Standard Uncertainty (%) $u_i(\%)$	Degree of freedom V_{eff} or v_i
Measurement System								
1	– Probe Calibration	B	5.8	N	1	1	5.8	∞
2	– Axial isotropy	B	3.5	R	$\sqrt{3}$	0.5	1.43	∞



3	– Hemispherical Isotropy	B	5.9	R	$\sqrt{3}$	0.5	2.41	∞
4	– Boundary Effect	B	1	R	$\sqrt{3}$	1	0.58	∞
5	– Linearity	B	4.7	R	$\sqrt{3}$	1	2.71	∞
6	– System Detection Limits	B	1	R	$\sqrt{3}$	1	0.58	∞
7	Modulation response	B	0	N	1	1	0.00	
8	– Readout Electronics	B	0.5	N	1	1	0.50	∞
9	– Response Time	B	0.00	R	$\sqrt{3}$	1	0.00	∞
10	– Integration Time	B	1.4	R	$\sqrt{3}$	1	0.81	∞
11	– RF Ambient Conditions	B	3.0	R	$\sqrt{3}$	1	1.73	∞
12	– Probe Position Mechanical tolerance	B	1.4	R	$\sqrt{3}$	1	0.81	∞
13	– Probe Position with respect to Phantom Shell	B	1.4	R	$\sqrt{3}$	1	0.81	∞
14	– Extrapolation, Interpolation and Integration Algorithms for Max. SAR evaluation	B	2.3	R	$\sqrt{3}$	1	1.33	∞
Uncertainties of the DUT								
15	Deviation of experimental source from numerical source	A	4	N	1	1	4.00	5
16	Input Power and SAR drift measurement	A	5	R	$\sqrt{3}$	1	2.89	5
17	Dipole Axis to Liquid Distance	B	2	R	$\sqrt{3}$	1	1.2	∞
Phantom and Tissue Parameters								
18	– Phantom Uncertainty(shape	B	4	R	$\sqrt{3}$	1	2.31	∞



	and thickness tolerances)							
19	Uncertainty in SAR correction for deviation(in permittivity and conductivity)	B	2	N	1	1	2.00	
20	- Liquid Conductivity Target -tolerance	B	2.5	R	$\sqrt{3}$	0.6	1.95	∞
21	- Liquid Conductivity -measurement Uncertainty)	B	4	N	$\sqrt{3}$	1	0.92	9
22	- Liquid Permittivity Target tolerance	B	2.5	R	$\sqrt{3}$	0.6	1.95	∞
23	- Liquid Permittivity -measurement uncertainty	B	5	N	$\sqrt{3}$	1	1.15	∞
Combined Standard Uncertainty				RSS			10.15	
Expanded uncertainty (Confidence interval of 95 %)				K=2			20.29	



12. Equipment List

This table is a complete overview of the SAR measurement equipment. Devices used during the test described are marked .

	EQUIPMENT	Model	Serial number	Calibration Date	Due Date
<input checked="" type="checkbox"/>	SAR Probe	SSE2	SN41/18 EPGO330	2019/05/21	2020/05/20
<input checked="" type="checkbox"/>	SAR Probe	SSE2	SN41/18 EPGO334	2019/12/10	2021/12/09
<input checked="" type="checkbox"/>	Dipole	SID750	SN 23/15 DIP0G750-378	2017/11/27	2020/11/26
<input checked="" type="checkbox"/>	Dipole	SID835	SN 09/13 DIP0G835-217	2017/11/27	2020/11/26
<input type="checkbox"/>	Dipole	SID900	SN 09/13 DIP0G900-215	2017/11/27	2020/11/26
<input checked="" type="checkbox"/>	Dipole	SID1800	SN 09/13 DIP1G800-216	2017/11/27	2020/11/26
<input checked="" type="checkbox"/>	Dipole	SID1900	SN 09/13 DIP2G000-218	2017/11/27	2020/11/26
<input type="checkbox"/>	Dipole	SID2000	SN 09/13 DIP2G000-219	2017/11/27	2020/11/26
<input checked="" type="checkbox"/>	Dipole	SID2450	SN_09/13_DIP2G450-220	2017/11/27	2020/11/26
<input type="checkbox"/>	Dipole	SID2600	SN 32/14_DIP2G600-338	2017/11/27	2020/11/26
<input type="checkbox"/>	Dipole	SWG5500	SN15/15 WGA39	2017/11/27	2020/11/26
<input checked="" type="checkbox"/>	Multimeter	Keithley-2000	4014020	2020/04/03	2021/04/03
<input checked="" type="checkbox"/>	System Simulator(Agilent 8960)	E5515C	GB 47200710	2017/11/08	2020/11/26
<input checked="" type="checkbox"/>	System Simulator(R&S)	CMW500	130805	2019/07/30	2020/07/29
<input checked="" type="checkbox"/>	KEYSIGHT	E7515A	MY56040357	2020/04/03	2021/04/03
<input checked="" type="checkbox"/>	Vector Network Analyzer(R&S)	ZVB8	A0802530	2020/04/03	2021/04/03
<input checked="" type="checkbox"/>	PC 3.5 Fixed Match Calibration Kit	ZV-Z32	100571	2017/11/29	2020/11/28
<input checked="" type="checkbox"/>	Dielectric Probe Kit	SCLMP	SN 09/13 OCPG51	2017/11/27	2020/11/26
<input checked="" type="checkbox"/>	Signal Generator	SMU200A	A140801888	2020/03/16	2021/03/15
<input checked="" type="checkbox"/>	Amplifier	Nucletudes	143060	2020/03/16	2021/03/15
<input checked="" type="checkbox"/>	Directional Coupler	DC6180A	305827	2020/03/16	2021/03/15
<input checked="" type="checkbox"/>	Power Meter	NRP2	A140401673	2020/03/16	2021/03/15
<input checked="" type="checkbox"/>	Power Sensor	NPR-Z11	1138.3004.02-114072-nq	2020/03/16	2021/03/15
<input checked="" type="checkbox"/>	Power Meter	NRVS	A0802531	2020/03/16	2021/03/15
<input checked="" type="checkbox"/>	Power Sensor	NRV-Z4	100069	2020/03/16	2021/03/15



ANNEX A: Appendix A: SAR System performance Check Plots

(Please See Appendix A)

ANNEX B: Appendix B: SAR Measurement results Plots

(Please See Appendix B)

ANNEX C: Appendix C: Calibration reports

(Please See Appendix C)

ANNEX D: Appendix D: SAR Test Setup

(Please See Appendix D)

—End of the Report—