

# acknowledgment

## SPECIFICATION FOR APPROVAL

client

CUSTOMER: Yongman

Customer Item:

CUST P/N:

Tianxia material number:

TX P/N: TX-YM-Y0825S

product model

DESC:

φ 14. 0\*20. 5-0. 08\*24P-13TS-8-25C

date

DATE:

2023/08/02

edition Ben:

Version:

A. 0

| draw up<br>PREPARED BY | check<br>CHECKED BY | approve<br>APPROVED BY | Customer recognition<br>CUSTOMER APPROVE |
|------------------------|---------------------|------------------------|--|
| Luo<br>xiongbin        | ZhangYan            | Luo yongjun            |  |

## Shenzhen tianxia technology co., ltd

Address: Room 523-525, C33 Science and Technology Park, Zone 33, Baoan District, Shenzhen

TEL: 18718699959

E-mail: 2321113770@qq.com



SPECIFICATION

|                        |                                     |          |                         |
|------------------------|-------------------------------------|----------|-------------------------|
| Product model:<br>DESC | φ 14. 0*20. 5-0. 08*24P-13TS-8-25CC | Rev: A.0 | Customer CUST:          |
|                        |                                     |          | Customer item CUST P/N: |

I. DIMENSION:(mm)

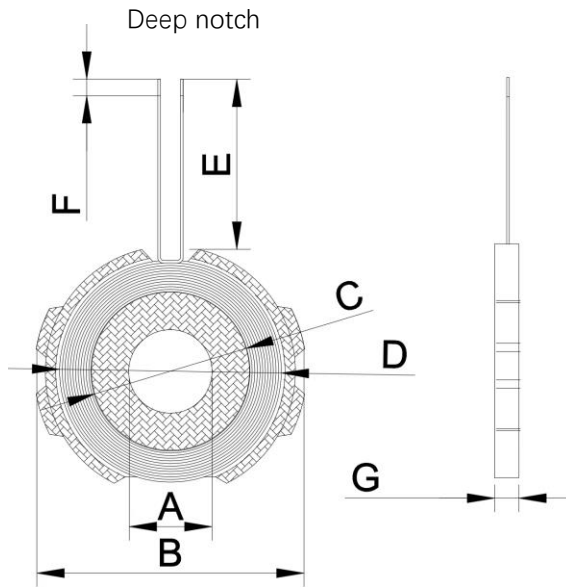

|   |          |
|---|----------|
| A | 8.0±0.5  |
| B | 25.0±0.5 |
| C | 15.0±1   |
| D | 20.5±1   |
| E | 12 mm    |
| F | 3.00±0.5 |
| G | 2.6±0.5  |
|   |          |
|   |          |
|   |          |
|   |          |
|   |          |
|   |          |
|   |          |
|   |          |

Note:

1. Coil cross outlet
2. The coil is attached with a round hard magnetic sheet, the size is φ8\*25\*1.0mm; Positive magnet
3. The lead wire outlet position is shown in the figure (the outlet wire is upward) When the deep gap is below
4. The overall thickness of the coil shall not exceed 3mm;
5. Double-wire tin dipping, with a length of 12mm, and the length of tin dipping is flush with the edge of the magnetic sheet.



Second, the schematic SCHEMATIC DIAGRAM

iii. winding parameter Winding Specification:

| serial number | post TERMINAL | Wire Diameter WIRE | cylinder number | direction of winding Winding Direction |
|---------------|---------------|--------------------|-----------------|--|
|               |               |                    | 7 Turns         |  |

| serial number NO. | project ITEM | post TERMINAL | standard SPECIFICATION        | test condition TEST FREQUENCY | Test instrument TEST EQUIPMENTS |
|-------------------|--------------|---------------|-------------------------------|-------------------------------|---------------------------------|
| 1                 | IND.         | S-F           | 4.4 uh 10% individual coil    | 100KHz/1.0V                   | LCZ METER 1062B                 |
| 2                 | IND.         | S-F           | 6.8 uh 10% with magnetic disk | 100KHz/1.0V                   | LCZ METER 1062B                 |

|                             |                            |
|-----------------------------|----------------------------|
| Draft/date PREPARED BY/DATE | Audit/date CHECKED BY/DATE |
| Luo Xiongbin 2023/08/02     | Zhang Yan 2023/08/02       |