



FCC PART 15.247 TEST REPORT

For

BYTECH NY INC

2585 West 13 Street, Brooklyn, NY 11223

FCC ID: 2AHN6-AUBS151

Report Type: Original Report	Product Type: BT Karaoke SPKR W/FM Radio-BK
Report Number: RSZ200714834-00	
Report Date: 2020-07-23	
Reviewed By: RF Engineer	Jimmy Xiao <i>Jimmy Xiao</i>
Prepared By: Bay Area Compliance Laboratories Corp. (Shenzhen) 6/F., West Wing, Third Phase of Wanli Industrial Building, Shihua Road, Futian Free Trade Zone, Shenzhen, Guangdong, China Tel: +86-755-33320018 Fax: +86-755-33320008 www.baclcorp.com.cn	

Note: This report must not be used by the customer to claim product certification, approval, or endorsement by A2LA* or any agency of the Federal Government. This report may contain data that are not covered by the A2LA accreditation and are marked with an asterisk “★”.

BACL is not responsible for the authenticity of any test data provided by the applicant. Data included from the applicant that may affect test results are marked with an asterisk “*”. Customer model name, addresses, names, trademarks etc. are not considered data.

This report cannot be reproduced except in full, without prior written approval of the Company. Unless otherwise stated the results shown in this test report refer only to the sample(s) tested. This report is valid only with a valid digital signature. The digital signature may be available only under the Adobe software above version 7.0.

TABLE OF CONTENTS

GENERAL INFORMATION.....	4
PRODUCT DESCRIPTION FOR EQUIPMENT UNDER TEST (EUT).....	4
OBJECTIVE.....	4
RELATED SUBMITTAL(S)/GRANT(S).....	4
TEST METHODOLOGY.....	4
MEASUREMENT UNCERTAINTY.....	5
TEST FACILITY.....	5
SYSTEM TEST CONFIGURATION.....	6
DESCRIPTION OF TEST CONFIGURATION.....	6
EUT EXERCISE SOFTWARE.....	6
SPECIAL ACCESSORIES.....	6
EQUIPMENT MODIFICATIONS.....	6
SUPPORT EQUIPMENT LIST AND DETAILS.....	6
EXTERNAL I/O CABLE.....	6
BLOCK DIAGRAM OF TEST SETUP.....	7
SUMMARY OF TEST RESULTS.....	8
TEST EQUIPMENT LIST.....	9
FCC §15.247 (i) & §2.1091- MAXIMUM PERMISSIBLE EXPOSURE (MPE).....	11
APPLICABLE STANDARD.....	11
RESULT.....	11
FCC §15.203 – ANTENNA REQUIREMENT.....	12
APPLICABLE STANDARD.....	12
ANTENNA CONNECTOR CONSTRUCTION.....	12
FCC §15.207 (a) – AC LINE CONDUCTED EMISSIONS.....	13
APPLICABLE STANDARD.....	13
EUT SETUP.....	13
EMI TEST RECEIVER SETUP.....	13
TEST PROCEDURE.....	13
CORRECTED FACTOR & MARGIN CALCULATION.....	14
TEST DATA.....	14
FCC §15.205, §15.209 & §15.247(d) – RADIATED EMISSIONS.....	17
APPLICABLE STANDARD.....	17
EUT SETUP.....	17
EMI TEST RECEIVER & SPECTRUM ANALYZER SETUP.....	18
TEST PROCEDURE.....	18
CORRECTED AMPLITUDE & MARGIN CALCULATION.....	18
TEST DATA.....	18
FCC §15.247(a) (1)-CHANNEL SEPARATION TEST.....	26
APPLICABLE STANDARD.....	26
TEST PROCEDURE.....	26
TEST DATA.....	26
FCC §15.247(a) (1) – 20 dB EMISSION BANDWIDTH.....	29
APPLICABLE STANDARD.....	29

TEST PROCEDURE29
 TEST DATA29

FCC §15.247(a) (1) (iii)-QUANTITY OF HOPPING CHANNEL TEST35
 APPLICABLE STANDARD35
 TEST PROCEDURE35
 TEST DATA35

FCC §15.247(a) (1) (iii) - TIME OF OCCUPANCY (DWELL TIME).....38
 APPLICABLE STANDARD38
 TEST PROCEDURE38
 TEST DATA38

FCC §15.247(b) (1) - PEAK OUTPUT POWER MEASUREMENT49
 APPLICABLE STANDARD49
 TEST PROCEDURE49
 TEST DATA49

FCC §15.247(d) - BAND EDGES TESTING50
 APPLICABLE STANDARD50
 TEST PROCEDURE50
 TEST DATA50

GENERAL INFORMATION

Product Description for Equipment under Test (EUT)

Product	BT Karaoke SPKR W/FM Radio-BK
Tested Model	BY-AU-BS-151-BK
Frequency Range	Bluetooth: 2402~2480MHz
Peak Conducted Output Power	Bluetooth: 1.02dBm
Modulation Technique	Bluetooth: GFSK, $\pi/4$ -DQPSK, 8DPSK
Antenna Specification	-0.58 dBi
Voltage Range	DC 3.7 V from battery
Date of Test	2020-07-16 to 2020-07-21
Sample serial number	RSZ200714834-RF-S1 (Assigned by BAACL, Shenzhen)
Received date	2020-07-14
Sample/EUT Status	Good condition

Objective

This test report is prepared on behalf of BYTECH NY INC in accordance with Part 2-Subpart J, Part 15-Subparts A and C of the Federal Communication Commissions rules.

The tests were performed in order to determine compliance with FCC Part 15, Subpart C, section 15.203, 15.205, 15.207, 15.209 and 15.247 rules.

Related Submittal(s)/Grant(s)

No related submittal(s).

Test Methodology

All measurements contained in this report were conducted with ANSI C63.10-2013, American National Standard of Procedures for Compliance Testing of Unlicensed Wireless Devices.

For Radiated Emissions testing, please refer to DA 00-705 Released March 30, 2000, Filing and Measurement Guidelines for Frequency Hopping Spread Spectrum Systems.

All emissions measurement was performed at Bay Area Compliance Laboratories Corp. (Shenzhen). The radiated testing was performed at an antenna-to-EUT distance of 3 meters.

Measurement Uncertainty

Parameter		Uncertainty
Occupied Channel Bandwidth		±5%
RF Output Power with Power meter		±0.73dB
RF conducted test with spectrum		±1.6dB
AC Power Lines Conducted Emissions		±1.95dB
Emissions, Radiated	Below 1GHz	±4.75dB
	Above 1GHz	±4.88dB
Temperature		±1°C
Humidity		±6%
Supply voltages		±0.4%

Note: The extended uncertainty given in this report is obtained by combining the standard uncertainty times the coverage factor K with the 95% confidence interval. Otherwise required by the applicant or Product Regulations, Decision Rule in this report did not consider the uncertainty.

Test Facility

The Test site used by Bay Area Compliance Laboratories Corp. (Shenzhen) to collect test data is located on the 6/F., West Wing, Third Phase of Wanli Industrial Building, Shihua Road, Futian Free Trade Zone, Shenzhen, Guangdong, China.

The test site has been approved by the FCC under the KDB 974614 D01 and is listed in the FCC Public Access Link (PAL) database, FCC Registration No.: 342867, the FCC Designation No.: CN1221.

The test site has been registered with ISED Canada under ISED Canada Registration Number 3062B.

SYSTEM TEST CONFIGURATION

Description of Test Configuration

The system was configured for testing in an engineering mode.

EUT Exercise Software

“BT_Tool V1.0.1.0” exercise software was used and the power level is 7.

Special Accessories

No special accessory.

Equipment Modifications

No modification was made to the EUT tested.

Support Equipment List and Details

Manufacturer	Description	Model	Serial Number
Dongguan Aohai Power Technology Co.,Ltd.	Adapter	A8-501000	A1906034835
Unknown	Adapter	Unknown	B1258743252
Kingston	USB Disk	DT100G3(32G)	Q1241111245
Unknown	SD Card	Unknown	DD12452145

External I/O Cable

Cable Description	Length (m)	From Port	To
Un-shielding Detachable USB Cable	1.0	EUT	Adapter
Un-shielding Detachable Audio Cable	1.9	EUT	Microphone

Block Diagram of Test Setup

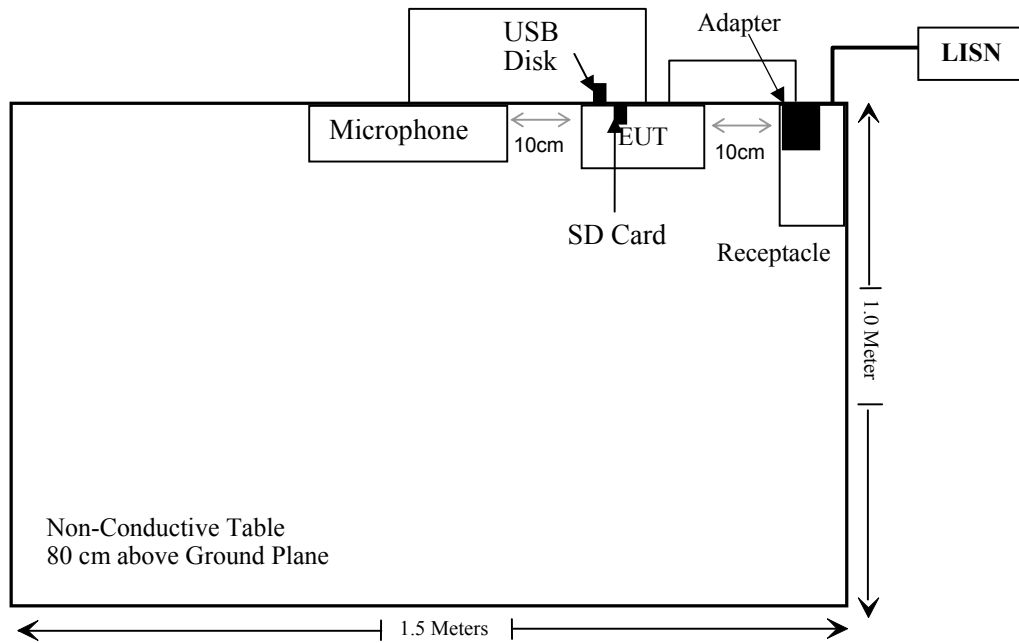

SUMMARY OF TEST RESULTS

FCC Rules	Description of Test	Result
§15.247 (i), §2.1091	Maximum Permissible Exposure(MPE)	Compliance
§15.203	Antenna Requirement	Compliance
§15.207(a)	AC Line Conducted Emissions	Compliance
§15.205, §15.209 & §15.247(d)	Radiated Emissions	Compliance
§15.247(a)(1)	20 dB Emission Bandwidth	Compliance
§15.247(a)(1)	Channel Separation Test	Compliance
§15.247(a)(1)(iii)	Time of Occupancy (Dwell Time)	Compliance
§15.247(a)(1)(iii)	Quantity of hopping channel Test	Compliance
§15.247(b)(1)	Peak Output Power Measurement	Compliance
§15.247(d)	Band edges	Compliance

TEST EQUIPMENT LIST

Manufacturer	Description	Model	Serial Number	Calibration Date	Calibration Due Date
Conducted Emissions Test					
Rohde & Schwarz	EMI Test Receiver	ESCI	101120	2020/7/9	2021/7/8
Rohde & Schwarz	LISN	ENV216	101613	2020/1/22	2021/1/21
Rohde & Schwarz	Transient Limitor	ESH3Z2	DE25985	2019/11/29	2020/11/28
Unknown	CE Cable	CE Cable	UF A210B-1-0720-504504	2019/11/29	2020/11/28
Rohde & Schwarz	CE Test software	EMC 32	V8.53.0	NCR	NCR
Radiated Emission Test					
R&S	EMI Test Receiver	ESR3	102455	2020/7/9	2021/7/8
Sonoma instrument	Pre-amplifier	310 N	186238	2020/4/20	2021/4/20
Sunol Sciences	Broadband Antenna	JB1	A040904-1	2017/12/22	2020/12/21
Unknown	Cable 2	RF Cable 2	F-03-EM197	2019/11/29	2020/11/28
Unknown	Cable	Chamber Cable 1	F-03-EM236	2019/11/29	2020/11/28
Rohde & Schwarz	Auto test software	EMC 32	V9.10	NCR	NCR
Rohde & Schwarz	Spectrum Analyzer	FSV40-N	102259	2019/7/22	2020/7/21
COM-POWER	Pre-amplifier	PA-122	181919	2019/11/29	2020/11/28
Quinstar	Amplifier	QLW-18405536-J0	15964001002	2019/11/29	2020/11/28
Sunol Sciences	Horn Antenna	DRH-118	A052604	2017/12/22	2020/12/21
Insulted Wire Inc.	RF Cable	SPS-2503-3150	02222010	2019/11/29	2020/11/28
Unknown	RF Cable	W1101-EQ1 OUT	F-19-EM005	2019/11/29	2020/11/28
SNSD	Band Reject filter	BSF2402-2480MN-0898-001	2.4G filter	2020/4/20	2021/4/20
Ducommun Technologies	Horn antenna	ARH-4223-02	1007726-021304	2017/12/6	2020/12/5
RF Conducted Test					
Agilent	USB Wideband Power Sensor	U2021XA	MY54250003	2020/7/10	2021/7/9
Rohde & Schwarz	SPECTRUM ANALYZER	FSU26	200120	2020/3/2	2021/3/1
WEINSCHL	3dB Attenuator	Unknown	Unknown	2019/11/29	2020/11/28
WEINSCHL	10dB Attenuator	5324	AU3842	2019/11/29	2020/11/28
Unknown	RF Cable	Unknown	2301 276	2019/11/29	2020/11/28

* **Statement of Traceability:** Bay Area Compliance Laboratories Corp. (Shenzhen) attests that all calibrations have been performed in accordance to requirements that traceable to National Primary Standards and International System of Units (SI).

FCC §15.247 (i) & §2.1091- MAXIMUM PERMISSIBLE EXPOSURE (MPE)

Applicable Standard

According to subpart 15.247 (i) and subpart 2.1091 systems operating under the provisions of this section shall be operated in a manner that ensures the public is not exposed to RF energy level in excess of the communication guidelines.

Limits for General Population/Uncontrolled Exposure

Limits for General Population/Uncontrolled Exposure				
Frequency Range (MHz)	Electric Field Strength (V/m)	Magnetic Field Strength (A/m)	Power Density (mW/cm ²)	Averaging Time (Minutes)
0.3-1.34	614	1.63	*(100)	30
1.34-30	824/f	2.19/f	*(180/f ²)	30
30-300	27.5	0.073	0.2	30
300-1500	/	/	f/1500	30
1500-100,000	/	/	1.0	30

f = frequency in MHz

* = Plane-wave equivalent power density

Result

Calculated Formulary:

Predication of MPE limit at a given distance

$$S = \frac{PG}{4\pi R^2}$$

S = power density (in appropriate units, e.g. mW/cm²)

P = power input to the antenna (in appropriate units, e.g., mW).

G = power gain of the antenna in the direction of interest relative to an isotropic radiator, the power gain factor, is normally numeric gain.

R = distance to the center of radiation of the antenna (appropriate units, e.g., cm)

Frequency (MHz)	Antenna Gain		Tune up conducted power		Evaluation Distance (cm)	Power Density (mW/cm ²)	MPE Limit (mW/cm ²)
	(dBi)	(numeric)	(dBm)	(mW)			
2402-2480	-0.58	0.87	1.5	1.41	20	0.0002	1

Note: To maintain compliance with the FCC’s RF exposure guidelines, place the equipment at least 20cm from nearby persons.

Result: Compliance

FCC §15.203 – ANTENNA REQUIREMENT

Applicable Standard

According to FCC § 15.203, an intentional radiator shall be designed to ensure that no antenna other than that furnished by the responsible party shall be used with the device. The use of a permanently attached antenna or of an antenna that uses a unique coupling to the intentional radiator shall be considered sufficient to comply with the provisions of this Section. The manufacturer may design the unit so that a broken antenna can be replaced by the user, but the use of a standard antenna jack or electrical connector is prohibited.

Antenna Connector Construction

The EUT has one internal antenna arrangement, which was permanently attached and the antenna gain is -0.58 dBi, fulfill the requirement of this section. Please refer to the EUT photos.

Result: Compliance.

FCC §15.207 (a) – AC LINE CONDUCTED EMISSIONS

Applicable Standard

FCC §15.207(a)

EUT Setup



- Note: 1. Support units were connected to second LISN.
 2. Both of LISNs (AMN) 80 cm from EUT and at the least 80 cm from other units and other metal planes support units.

The measurement procedure of EUT setup is according with ANSI C63.10-2013. The related limit was specified in FCC Part 15.207.

The spacing between the peripherals was 10 cm.

EMI Test Receiver Setup

The EMI test receiver was set to investigate the spectrum from 150 kHz to 30 MHz.

During the conducted emission test, the EMI test receiver was set with the following configurations:

Frequency Range	IF B/W
150 kHz – 30 MHz	9 kHz

Test Procedure

Maximizing procedure was performed on the six (6) highest emissions of the EUT.

All final data was recorded in the Quasi-peak and average detection mode.

Corrected Factor & Margin Calculation

The Corrected factor is calculated by adding LISN VDF (Voltage Division Factor), Cable Loss and Transient Limiter Attenuation. The basic equation is as follows:

$$\text{Correction Factor} = \text{LISN VDF} + \text{Cable Loss} + \text{Transient Limiter Attenuation}$$

The “**Margin**” column of the following data tables indicates the degree of compliance with the applicable limit. For example, a margin of 7 dB means the emission is 7 dB below the limit. The equation for margin calculation is as follows:

$$\text{Margin} = \text{Limit} - \text{Corrected Amplitude}$$

Test Data

Environmental Conditions

Temperature:	25 °C
Relative Humidity:	65 %
ATM Pressure:	101.0 kPa

The testing was performed by Haiguo Li on 2020-07-17.

EUT operation mode: Charging & Transmitting

AC 120V/60 Hz, Line

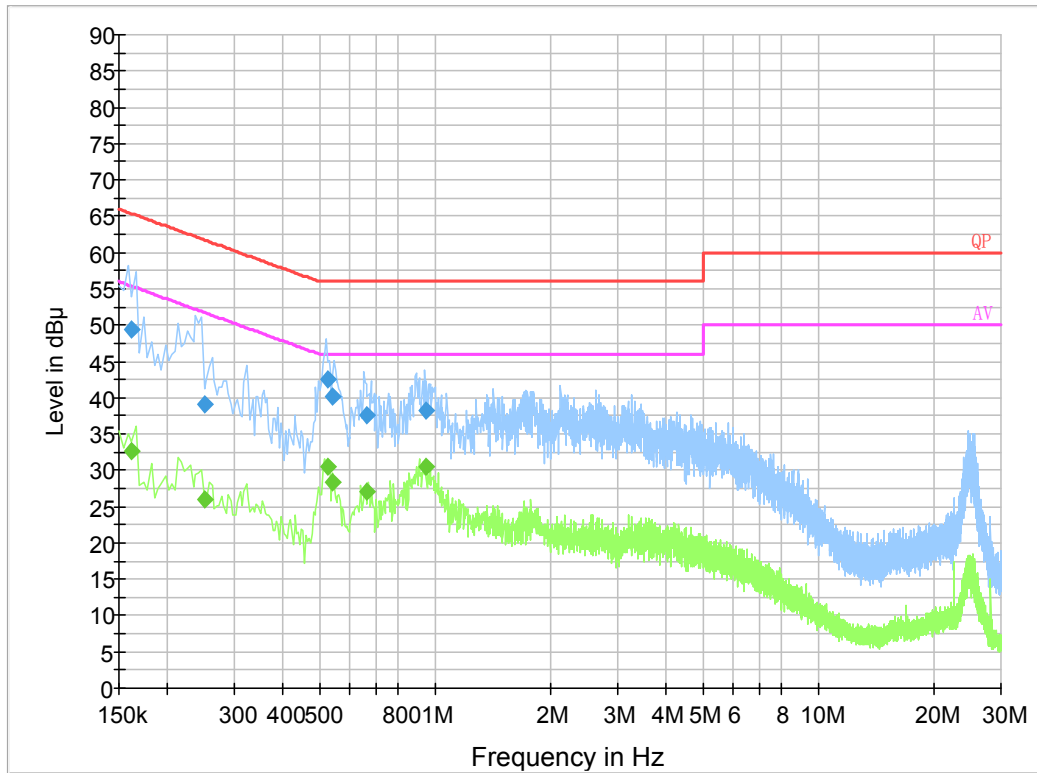

Frequency (MHz)	Corrected Amplitude (dBμV)	Correction Factor (dB)	Limit (dBμV)	Margin (dB)	Detector (PK/Ave./QP)
0.161500	49.3	19.9	65.4	16.1	QP
0.250501	39.2	19.8	61.7	22.5	QP
0.526170	42.5	19.8	56.0	13.5	QP
0.541810	40.1	19.8	56.0	15.9	QP
0.663810	37.6	19.8	56.0	18.4	QP
0.947870	38.2	19.8	56.0	17.8	QP
0.161500	32.7	19.9	55.4	22.7	Ave.
0.250501	26.0	19.8	51.7	25.7	Ave.
0.526170	30.4	19.8	46.0	15.6	Ave.
0.541810	28.3	19.8	46.0	17.7	Ave.
0.663810	27.1	19.8	46.0	18.9	Ave.
0.947870	30.6	19.8	46.0	15.4	Ave.

AC 120V/60 Hz, Neutral

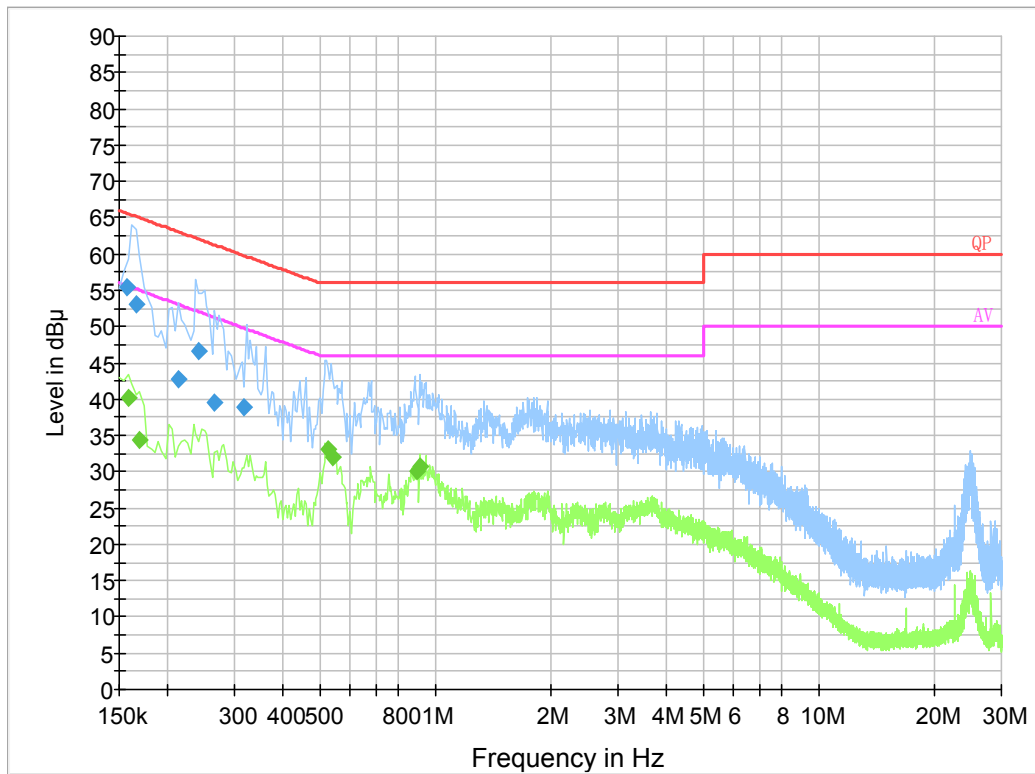

Frequency (MHz)	Corrected Amplitude (dBμV)	Correction Factor (dB)	Limit (dBμV)	Margin (dB)	Detector (PK/Ave./QP)
0.157500	55.5	19.8	65.6	10.1	QP
0.165500	53.0	19.8	65.2	12.2	QP
0.213500	42.7	19.8	63.1	20.4	QP
0.241500	46.7	19.8	62.0	15.3	QP
0.265500	39.5	19.7	61.3	21.8	QP
0.317170	39.0	19.7	59.8	20.8	QP
0.158000	40.1	19.8	55.6	15.5	Ave.
0.170000	34.5	19.9	55.0	20.5	Ave.
0.526000	33.1	19.8	46.0	12.9	Ave.
0.542000	31.9	19.8	46.0	14.1	Ave.
0.898000	30.1	19.7	46.0	15.9	Ave.
0.910000	30.8	19.7	46.0	15.2	Ave.

Note:

- 1) Correction Factor = LISN VDF (Voltage Division Factor) + Cable Loss + Transient Limiter Attenuation
- 2) Corrected Amplitude = Reading + Correction Factor
- 3) Margin = Limit - Corrected Amplitude

FCC §15.205, §15.209 & §15.247(d) – RADIATED EMISSIONS

Applicable Standard

FCC §15.205; §15.209; §15.247(d)

EUT Setup

Below 1 GHz:

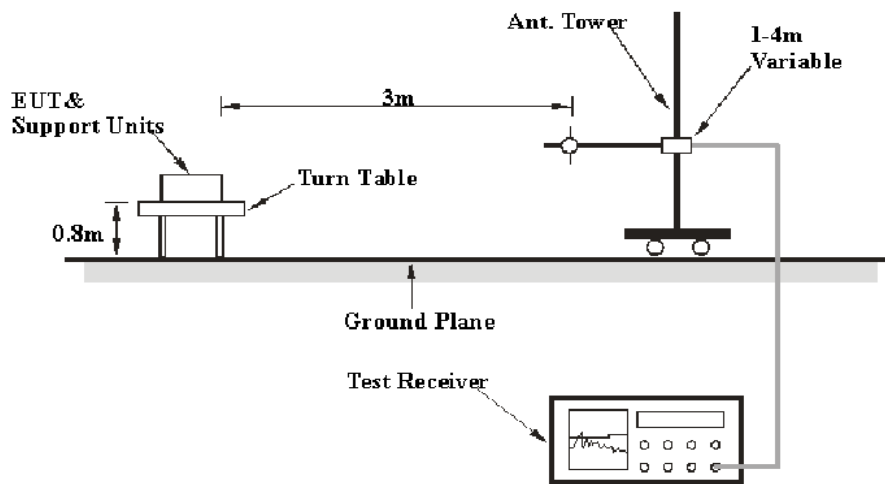

Above 1GHz:

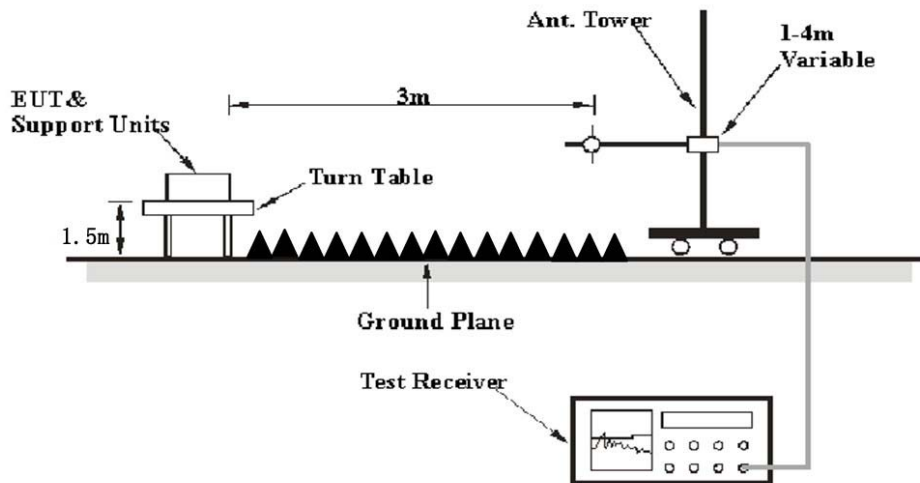

The radiated emission tests were performed in the 3 meters, using the setup accordance with the ANSI C63.10-2013. The specification used was the FCC 15.209 and FCC 15.247 limits.

EMI Test Receiver & Spectrum Analyzer Setup

The system was investigated from 30 MHz to 25 GHz.

During the radiated emission test, according to the DA 00-705 Released March 30, 2000, the EMI test receiver & Spectrum Analyzer Setup were set with the following configurations:

Frequency Range	RBW	Video B/W	IF B/W	Measurement
30 MHz – 1000 MHz	100 kHz	300 kHz	120 kHz	QP
Above 1 GHz	1 MHz	3 MHz	/	PK
	1 MHz	10 Hz	/	Average

Test Procedure

Maximizing procedure was performed on the highest emissions to ensure that the EUT complied with all installation combinations.

All final data was recorded in Quasi-peak detection mode for frequency range of 30 MHz -1 GHz and peak and Average detection modes for frequencies above 1 GHz.

Corrected Amplitude & Margin Calculation

The Corrected Amplitude is calculated by adding the Antenna Factor and Cable Loss, and subtracting the Amplifier Gain from the Meter Reading. The basic equation is as follows:

$$\text{Corrected Amplitude} = \text{Meter Reading} + \text{Antenna Factor} + \text{Cable Loss} - \text{Amplifier Gain}$$

The “**Margin**” column of the following data tables indicates the degree of compliance with the applicable limit. For example, a margin of 7dB means the emission is 7dB below the limit. The equation for margin calculation is as follows:

$$\text{Margin} = \text{Limit} - \text{Corrected Amplitude}$$

Test Data

Environmental Conditions

Temperature:	25~29 °C
Relative Humidity:	51~56 %
ATM Pressure:	101.0 kPa

The testing was performed by Hams He on 2020-07-20 for below 1GHz and by Charlie Cha from 2020-07-17 to 2020-07-18 for above 1GHz.

EUT operation mode: Transmitting

30 MHz~1 GHz: (the worst case is 8DPSK mode, Low channel)

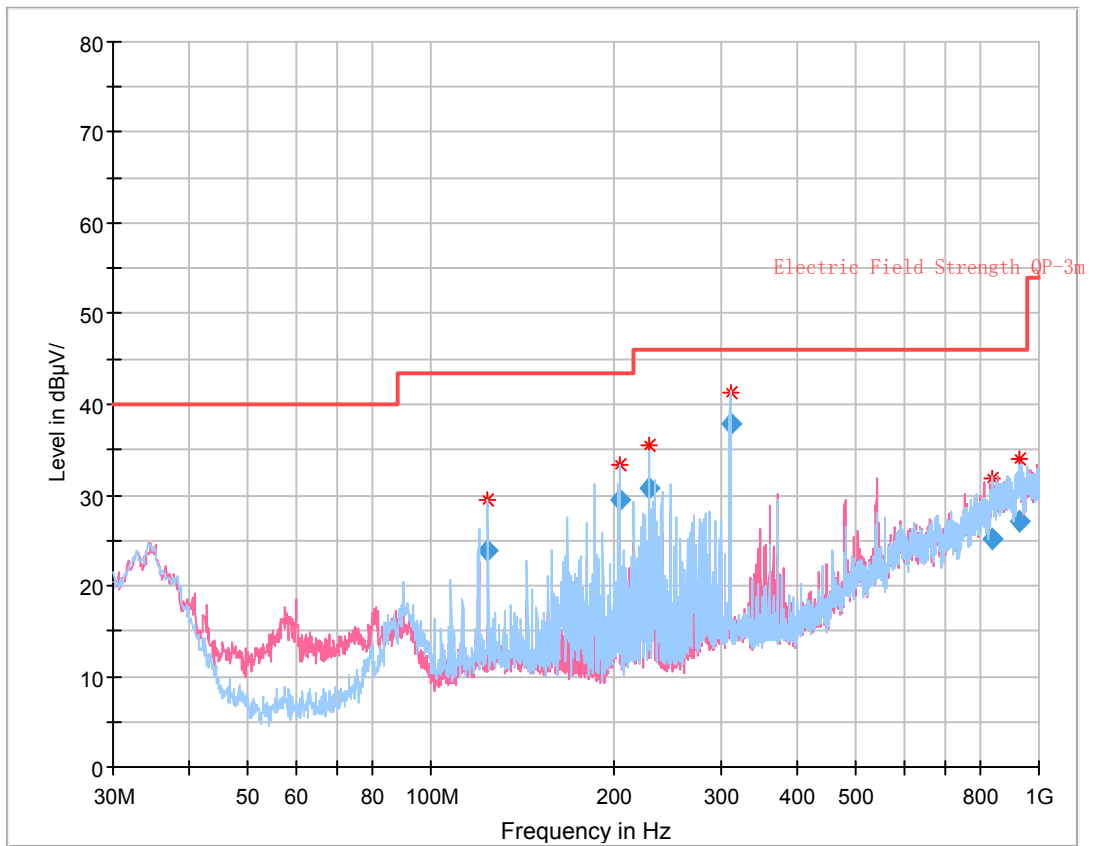

Frequency (MHz)	Corrected Amplitude (dBµV/m)	Antenna height (cm)	Antenna Polarity	Turntable position (degree)	Correction Factor (dB/m)	Limit (dBµV/m)	Margin (dB)
124.090000	23.79	293.0	H	195.0	-14.0	43.50	19.71
203.999625	29.46	129.0	H	90.0	-13.8	43.50	14.04
227.993500	30.67	127.0	H	114.0	-14.0	46.00	15.33
310.486500	37.79	103.0	H	178.0	-10.7	46.00	8.21
835.567875	25.14	377.0	H	310.0	2.7	46.00	20.86
932.183375	27.19	227.0	V	313.0	4.8	46.00	18.81

1 GHz - 25 GHz: (Scan with GFSK, $\pi/4$ -DQPSK, 8DPSK mode, the worst case is in 8DPSK Mode)

Frequency (MHz)	Receiver		Turntable Degree	Rx Antenna		Corrected Factor (dB/m)	Corrected Amplitude (dB μ V/m)	Limit (dB μ V/m)	Margin (dB)
	Reading (dB μ V)	PK/QP/Ave.		Height (m)	Polar (H/V)				
Low Channel (2402 MHz)									
2335.62	28.78	PK	136	1.1	H	31.64	60.42	74	13.58
2335.62	13.64	Ave.	136	1.1	H	31.64	45.28	54	8.72
2488.32	28.74	PK	1	1.8	H	32.13	60.87	74	13.13
2488.32	13.62	Ave.	1	1.8	H	32.13	45.75	54	8.25
4804.00	47.23	PK	244	1.0	H	6.28	53.51	74	20.49
4804.00	35.20	Ave.	244	1.0	H	6.28	41.48	54	12.52
Middle Channel (2441 MHz)									
4882.00	45.95	PK	69	1.5	H	6.76	52.71	74	21.29
4882.00	33.59	Ave.	69	1.5	H	6.76	40.35	54	13.65
High Channel (2480 MHz)									
2338.96	28.77	PK	200	2.0	H	31.64	60.41	74	13.59
2338.96	13.65	Ave.	200	2.0	H	31.64	45.29	54	8.71
2489.74	28.86	PK	354	1.5	H	32.13	60.99	74	13.01
2489.74	13.72	Ave.	354	1.5	H	32.13	45.85	54	8.15
4960.00	44.56	PK	12	1.5	H	6.80	51.36	74	22.64
4960.00	31.85	Ave.	12	1.5	H	6.80	38.65	54	15.35

Note:

Corrected Factor = Antenna factor (RX) + Cable Loss – Amplifier Factor

Corrected Amplitude = Corrected Factor + Reading

Margin = Limit - Corrected. Amplitude

The other spurious emission which is 20dB to the limit was not recorded.

**Pre-scan with Low channel Peak
Horizontal**

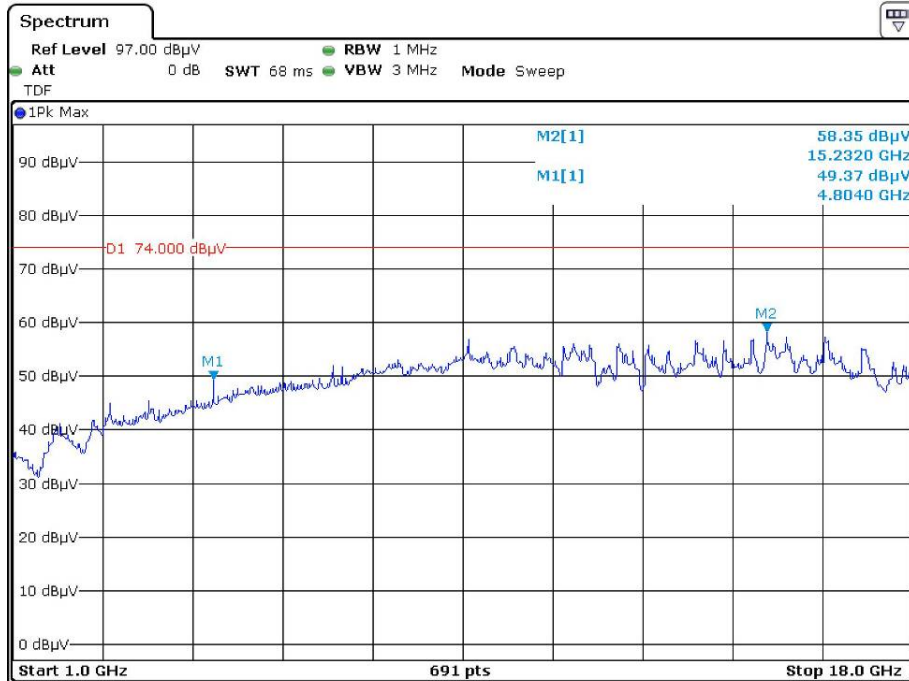

Date: 18.JUL.2020 07:00:45

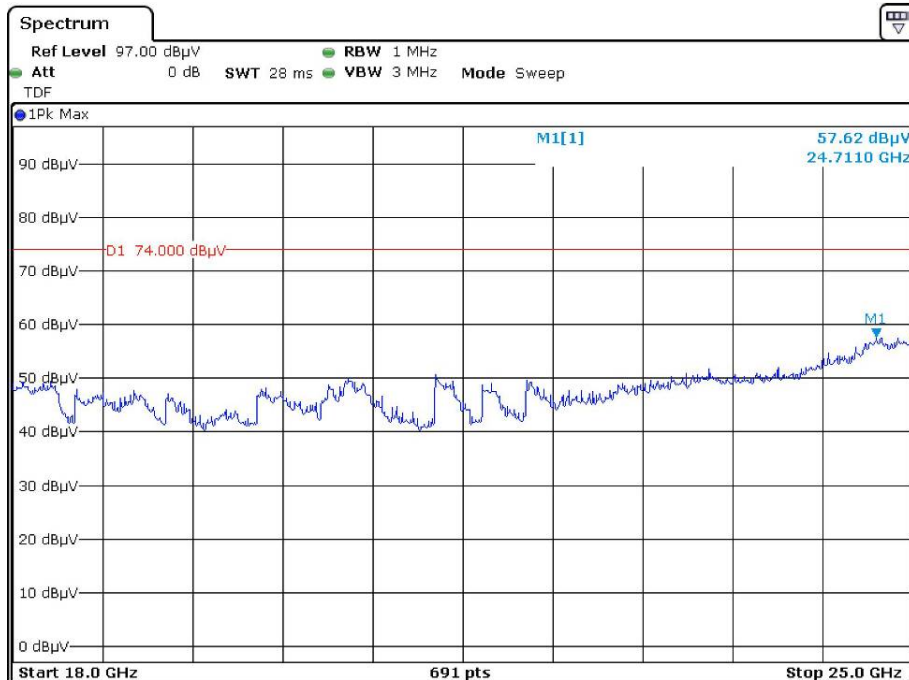

Date: 18.JUL.2020 07:50:01

Vertical

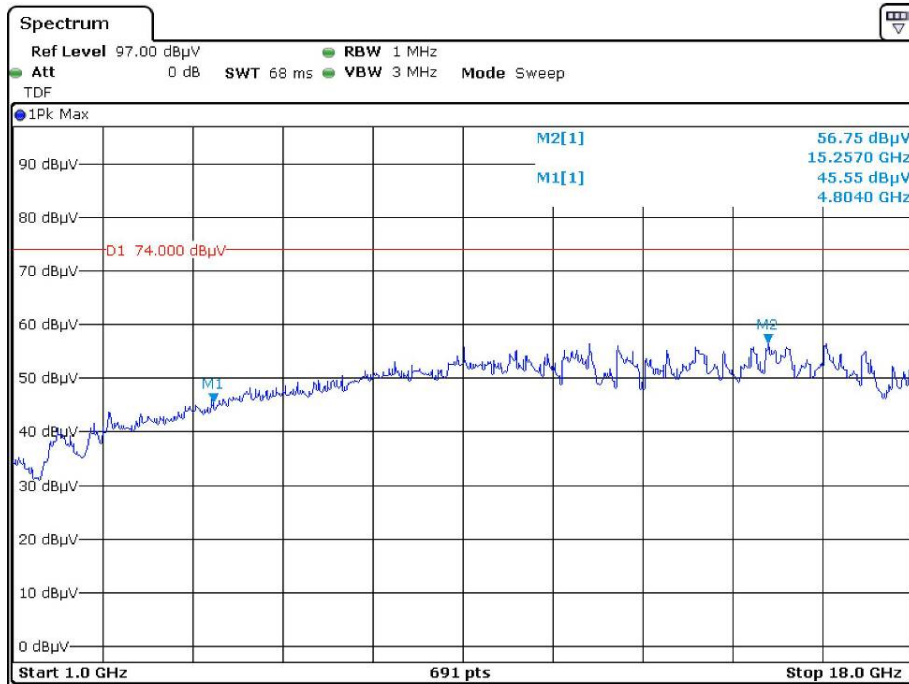

Date: 18.JUL.2020 07:13:19

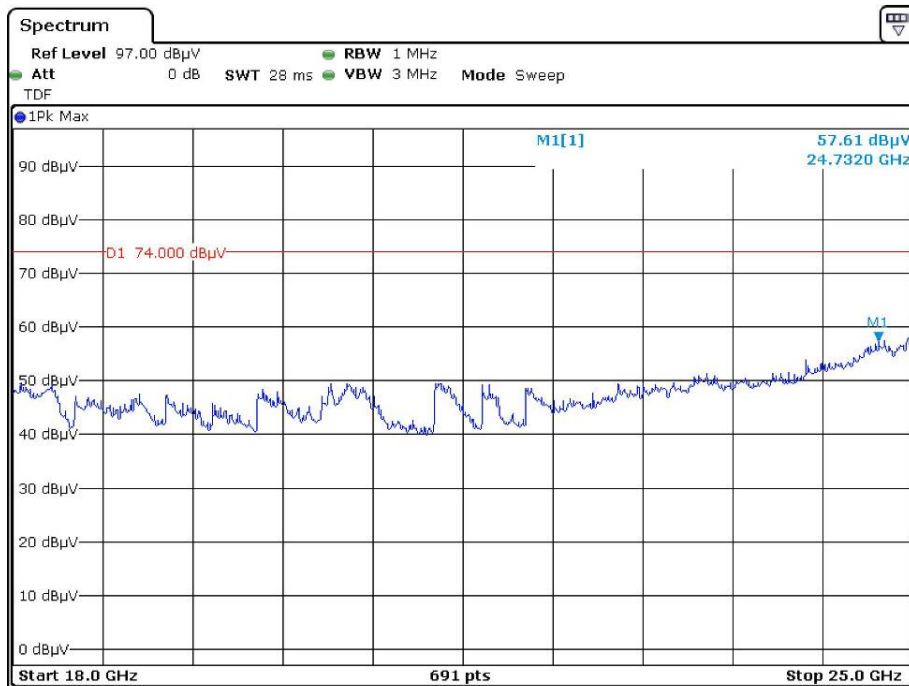

Date: 18.JUL.2020 07:57:25

Pre-scan for Average Horizontal

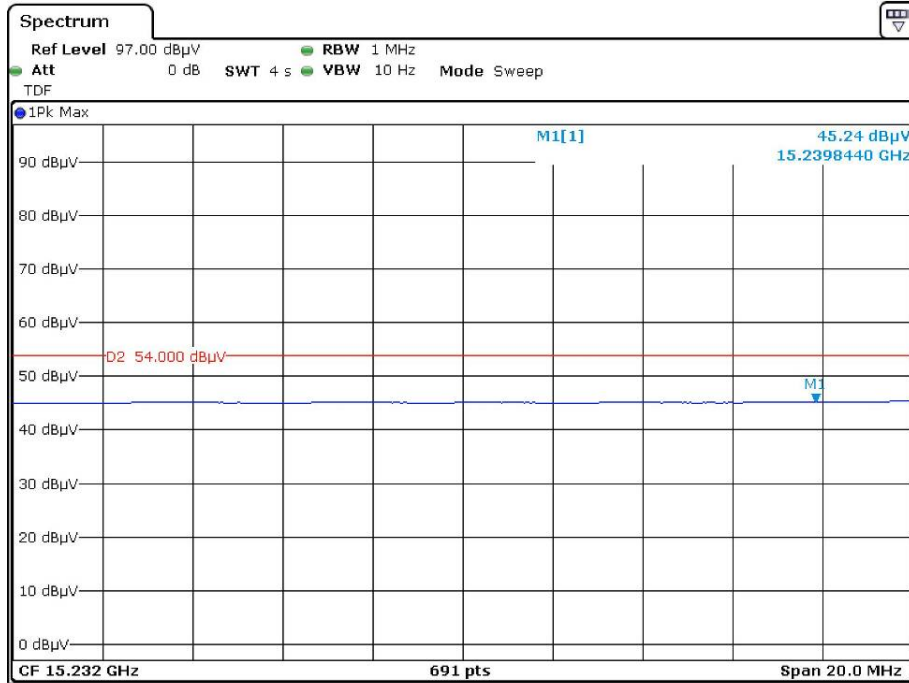

Date: 18.JUL.2020 07:03:25

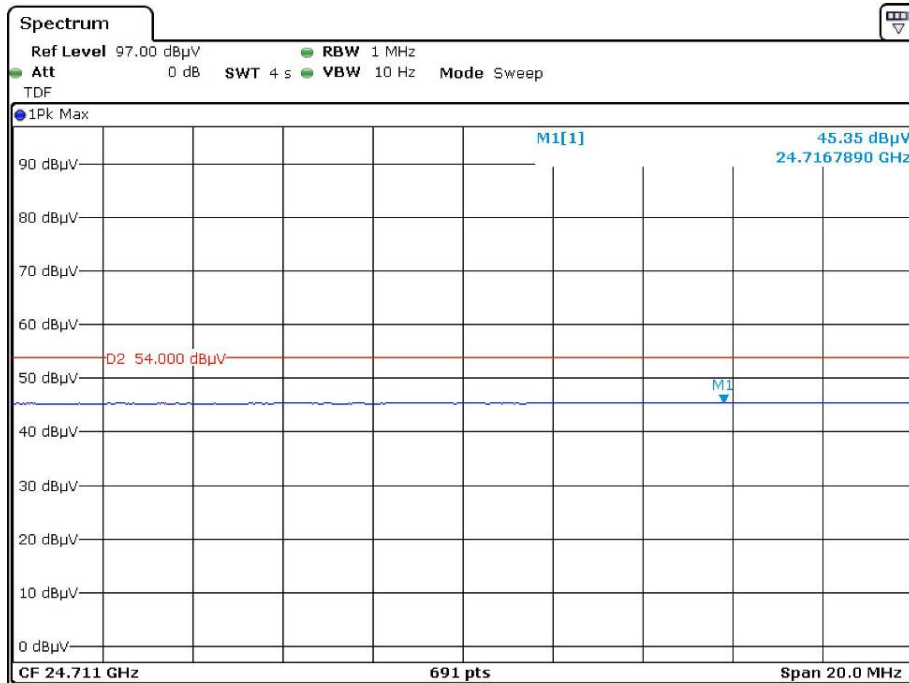

Date: 18.JUL.2020 07:53:44

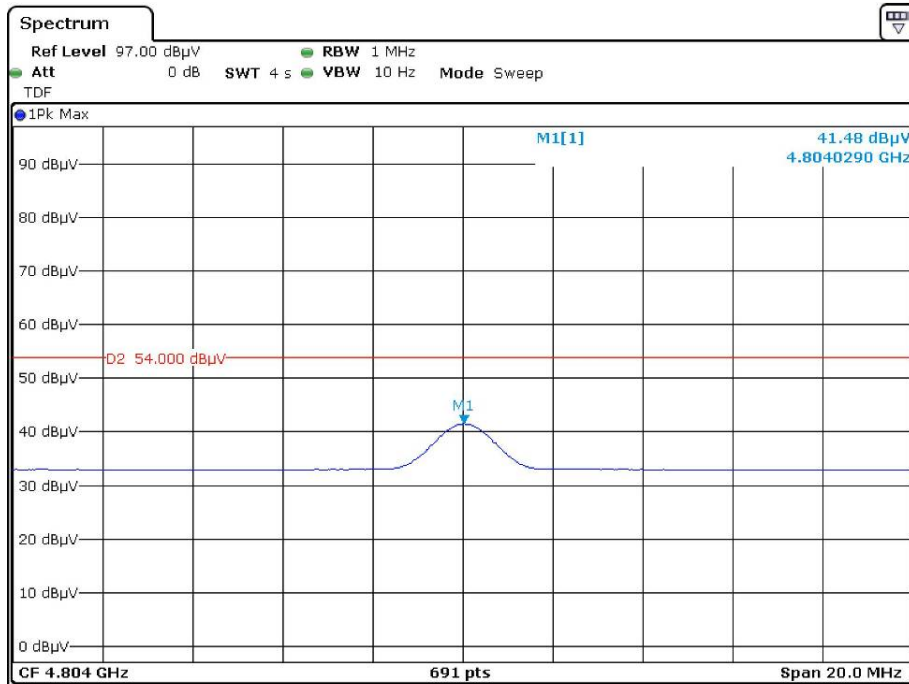

Date: 18.JUL.2020 07:06:34

Vertical

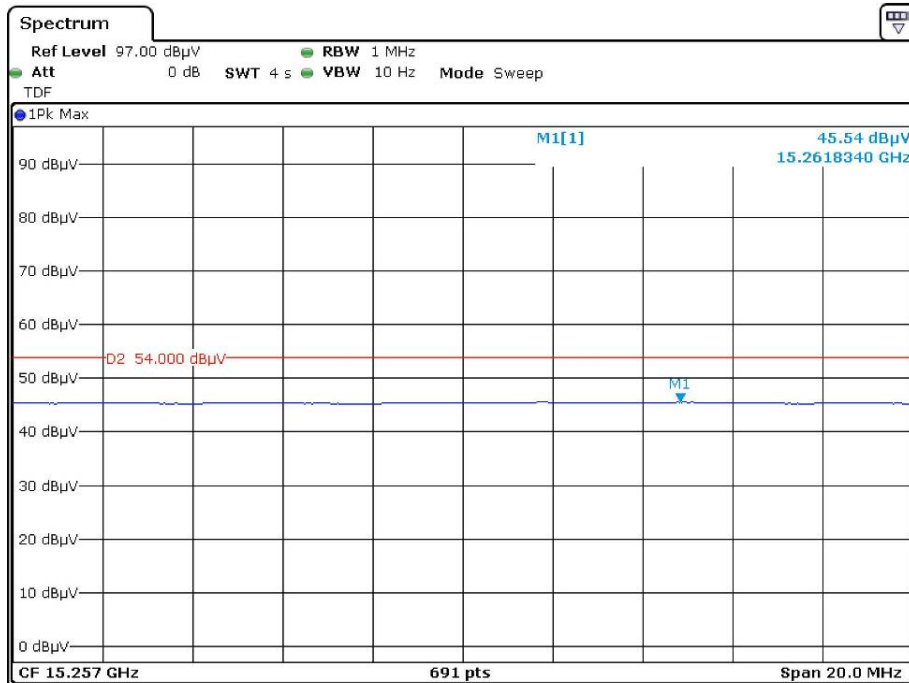

Date: 18.JUL.2020 07:15:53

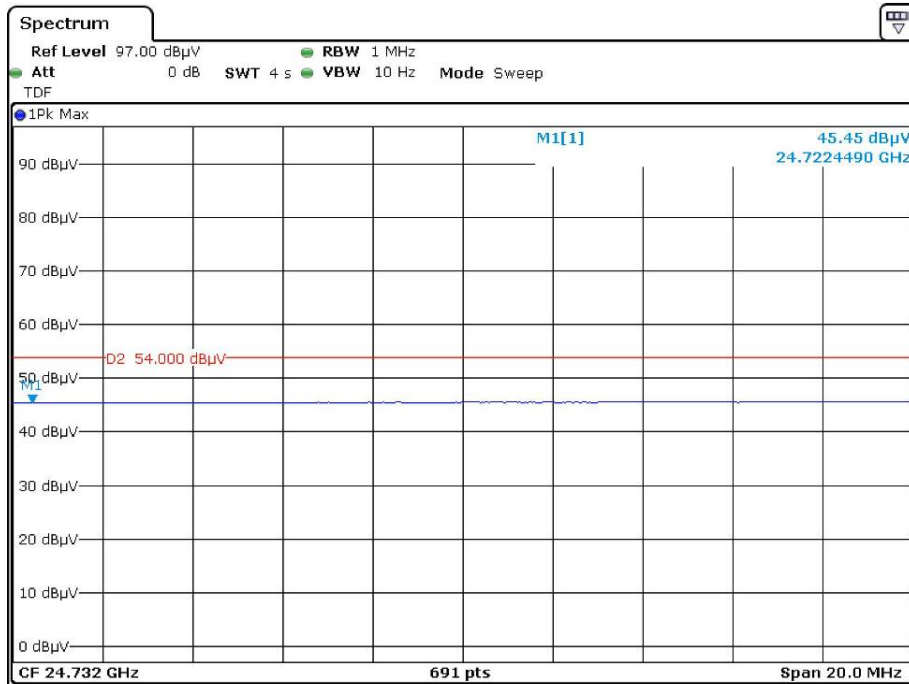

Date: 18.JUL.2020 07:59:16

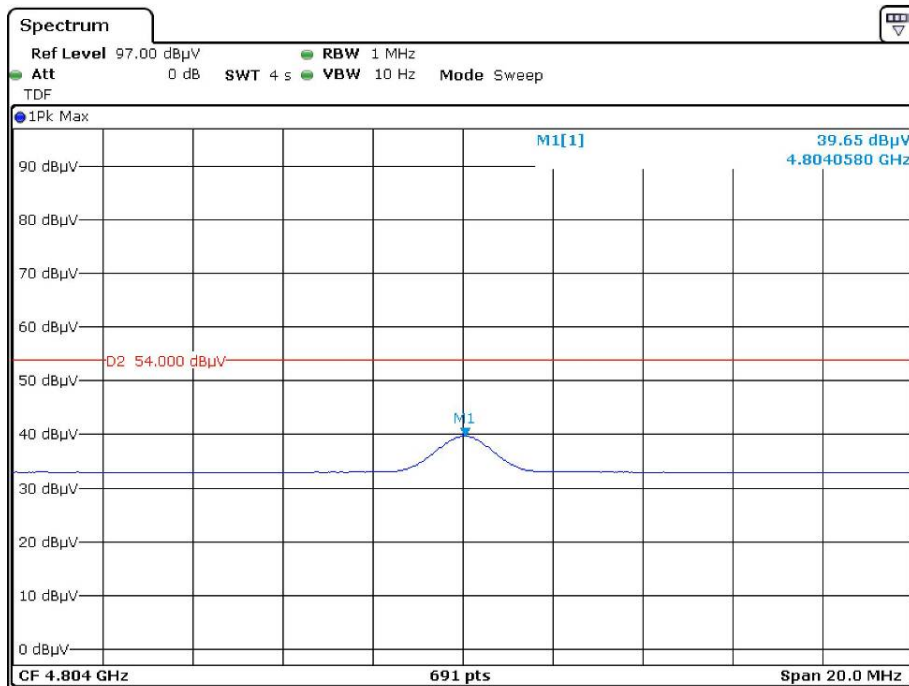

Date: 18.JUL.2020 07:19:06

FCC §15.247(a) (1)-CHANNEL SEPARATION TEST

Applicable Standard

Frequency hopping systems shall have hopping channel carrier frequencies separated by a minimum of 25 kHz or the 20 dB bandwidth of the hopping channel, whichever is greater. Alternatively, frequency hopping systems operating in the 2400-2483.5 MHz band may have hopping channel carrier frequencies that are separated by 25 kHz or two-thirds of the 20 dB bandwidth of the hopping channel, whichever is greater provided the systems operate with an output power no greater than 125 mW. The system shall hop to channel frequencies that are selected at the system hopping rate from a pseudo randomly ordered list of hopping frequencies. Each frequency must be used equally on the average by each transmitter. The system receivers shall have input bandwidths that match the hopping channel bandwidths of their corresponding transmitters and shall shift frequencies in synchronization with the transmitted signals.

Test Procedure

1. Set the EUT in transmitting mode, maxhold the channel.
2. Set the adjacent channel of the EUT and maxhold another trace.
3. Measure the channel separation.

Test Data

Environmental Conditions

Temperature:	24 °C
Relative Humidity:	50 %
ATM Pressure:	101.0 kPa

The testing was performed by Blaker Zhang on 2020-07-16.

EUT operation mode: Transmitting

Test Result: Compliance. Please refer to following table and plots.

Test Mode	Channel Separation (MHz)	20 dBc BW (MHz)	Two-thirds of the 20 dB bandwidth (MHz)	Channel Separation Limit	Result
BDR(GFSK)					
Hopping	0.997	0.909	0.606	> two-thirds of the 20 dB bandwidth	Compliance
EDR($\pi/4$-DQPSK)					
Hopping	1.000	1.258	0.839	> two-thirds of the 20 dB bandwidth	Compliance
EDR(8DPSK)					
Hopping	1.003	1.254	0.836	> two-thirds of the 20 dB bandwidth	Compliance

BDR (GFSK)

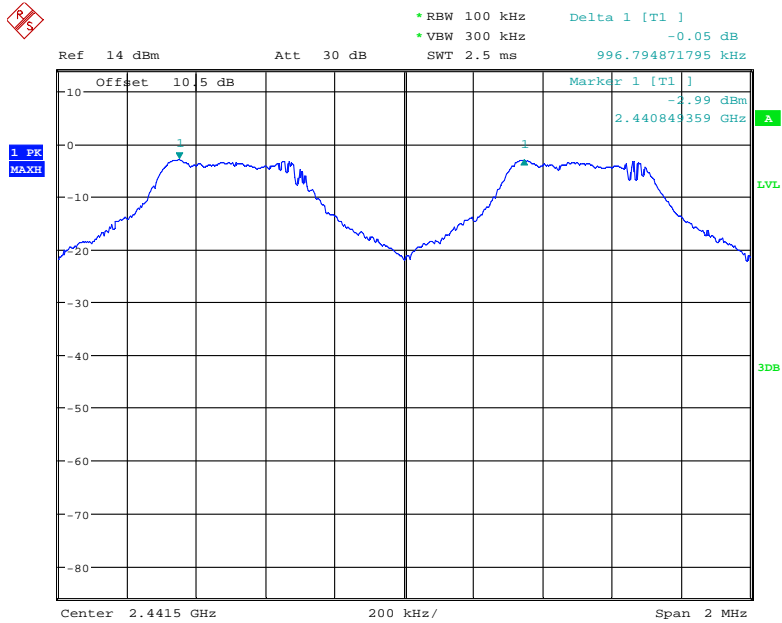

Date: 16.JUL.2020 16:48:06

EDR ($\pi/4$ -DQPSK)

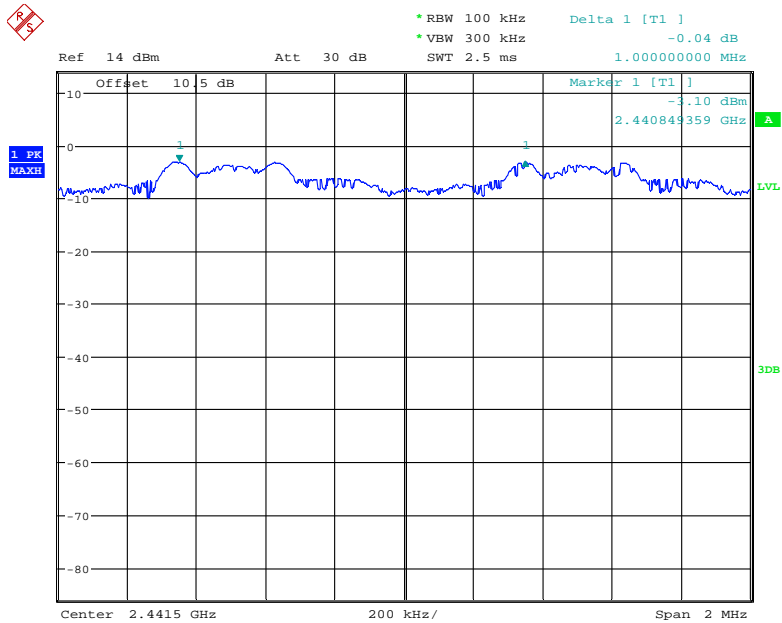

Date: 16.JUL.2020 16:52:11

EDR (8DPSK)

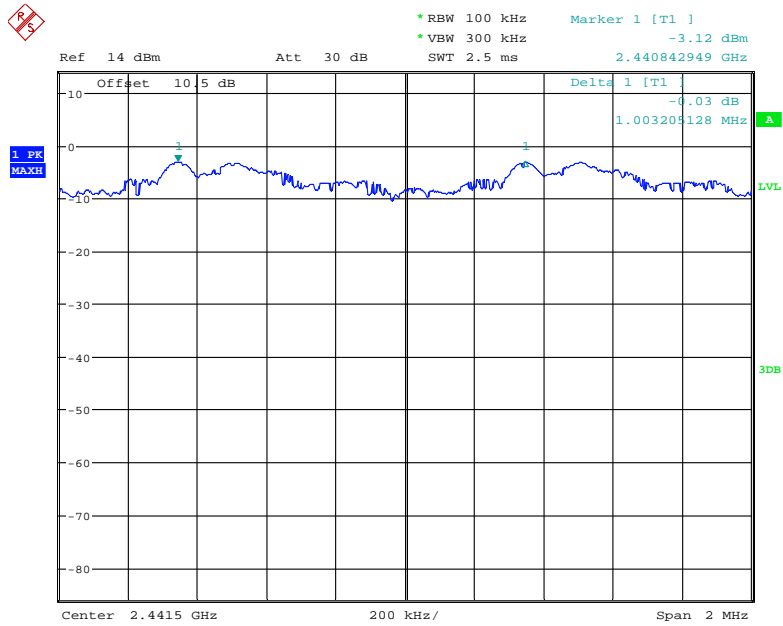

Date: 16.JUL.2020 16:55:53

FCC §15.247(a) (1) – 20 dB EMISSION BANDWIDTH

Applicable Standard

Alternatively, frequency hopping systems operating in the 2400–2483.5 MHz band may have hopping channel carrier frequencies that are separated by 25 kHz or two-thirds of the 20 dB bandwidth of the hopping channel, whichever is greater, provided the systems operate with an output power no greater than 125 mW.

Test Procedure

1. Check the calibration of the measuring instrument using either an internal calibrator or a known signal from an external generator.
2. Position the EUT without connection to measurement instrument. Turn on the EUT and connect it to measurement instrument. Then set it to any one convenient frequency within its operating range. Set a reference level on the measuring instrument equal to the highest peak value.
3. Measure the frequency difference of two frequencies that were attenuated 20 dB from the reference level. Record the frequency difference as the emission bandwidth.
4. Repeat above procedures until all frequencies measured were complete.

Test Data

Environmental Conditions

Temperature:	24 °C
Relative Humidity:	50 %
ATM Pressure:	101.0 kPa

The testing was performed by Blaker Zhang from 2020-07-16 to 2020-07-21.

EUT operation mode: Transmitting

Test Result: Pass

Test Result: Compliance. Please refer to following table and plots.

Mode	Channel	Frequency (MHz)	20 dB Emission Bandwidth (MHz)
BDR (GFSK)	Low	2402	0.912
	Middle	2441	0.909
	High	2480	0.909
EDR ($\pi/4$-DQPSK)	Low	2402	1.258
	Middle	2441	1.261
	High	2480	1.261
EDR (8DPSK)	Low	2402	1.264
	Middle	2441	1.264
	High	2480	1.254

BDR (GFSK): Low Channel

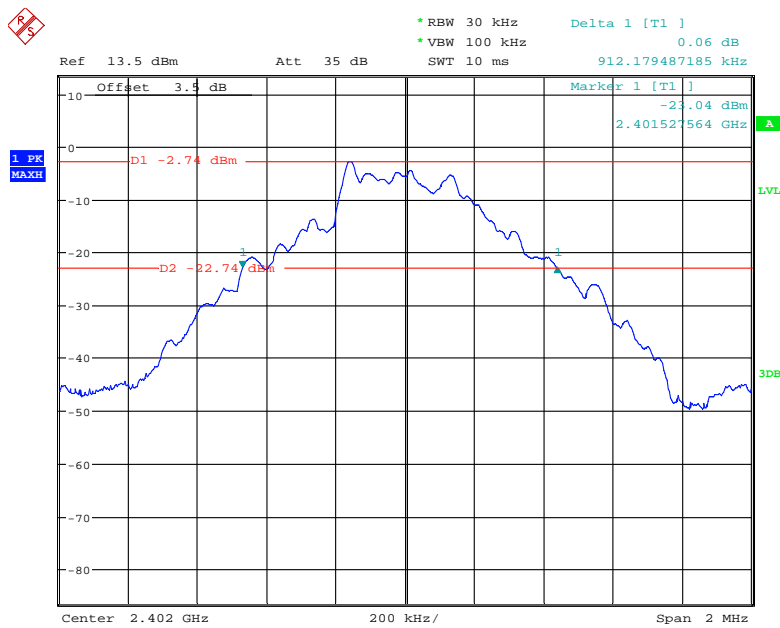

Date: 21.JUL.2020 16:36:29

BDR (GFSK): Middle Channel

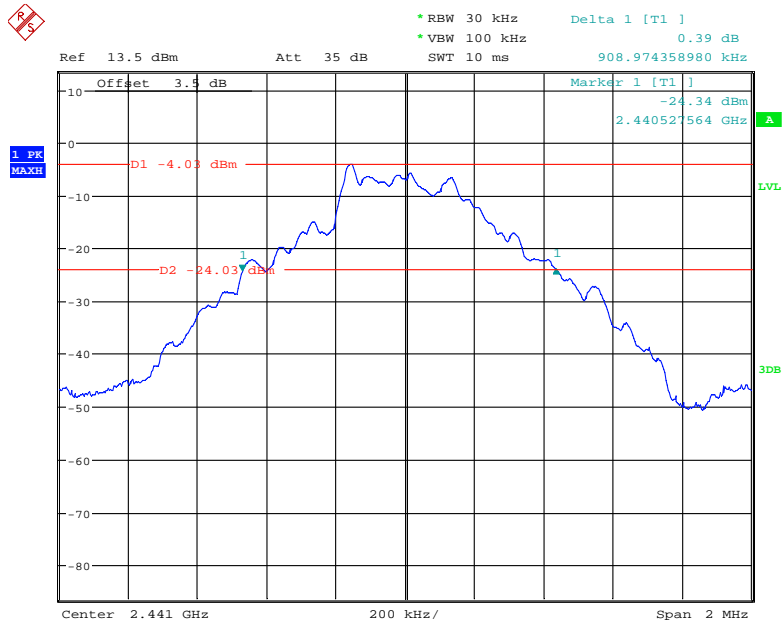

Date: 21.JUL.2020 16:39:29

BDR (GFSK): High Channel

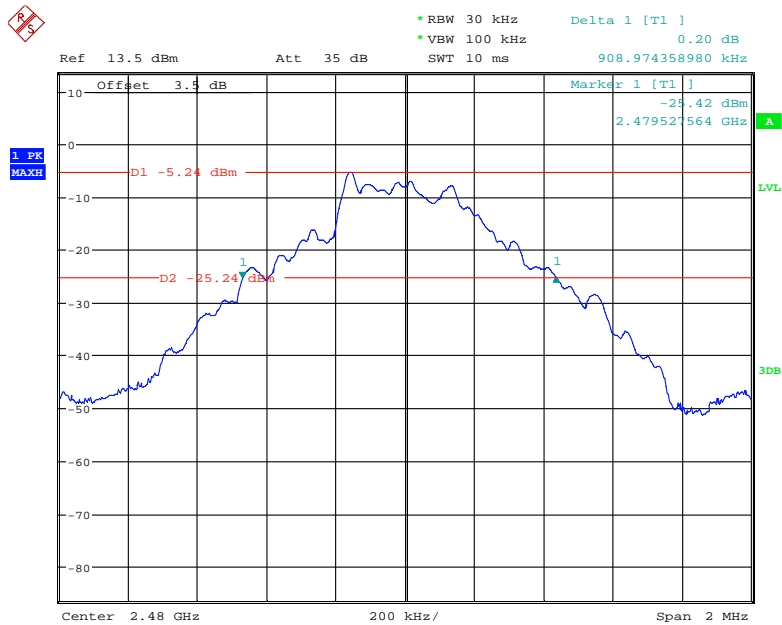

Date: 21.JUL.2020 16:41:49

EDR ($\pi/4$ -DQPSK): Low Channel

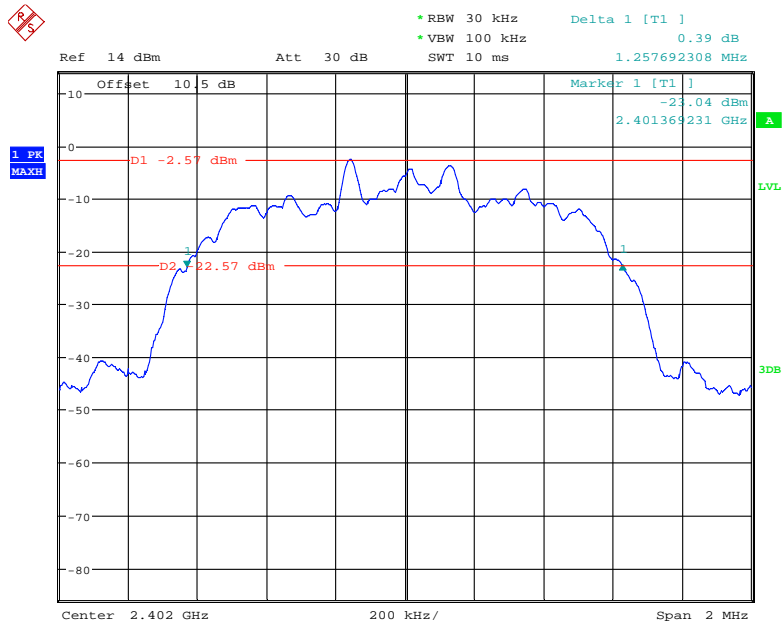

Date: 16.JUL.2020 15:50:46

EDR ($\pi/4$ -DQPSK): Middle Channel

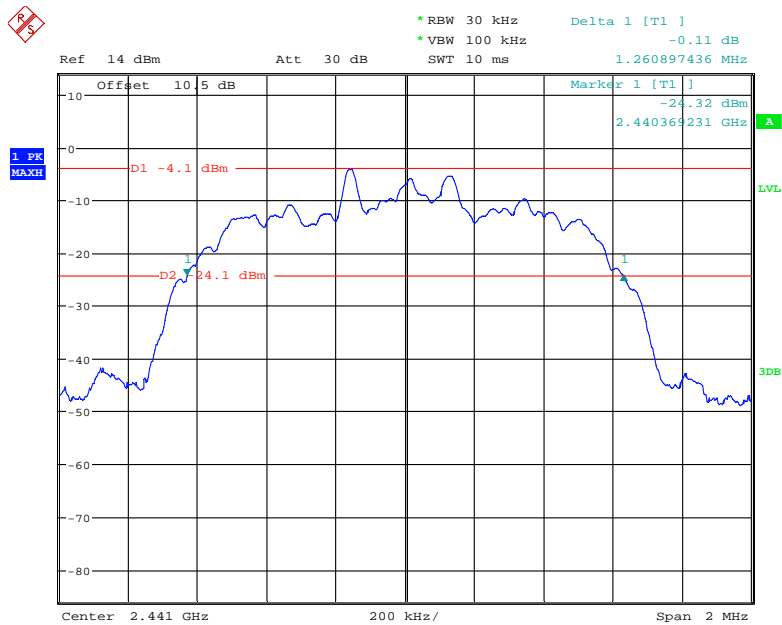

Date: 16.JUL.2020 15:52:17

EDR ($\pi/4$ -DQPSK): High Channel

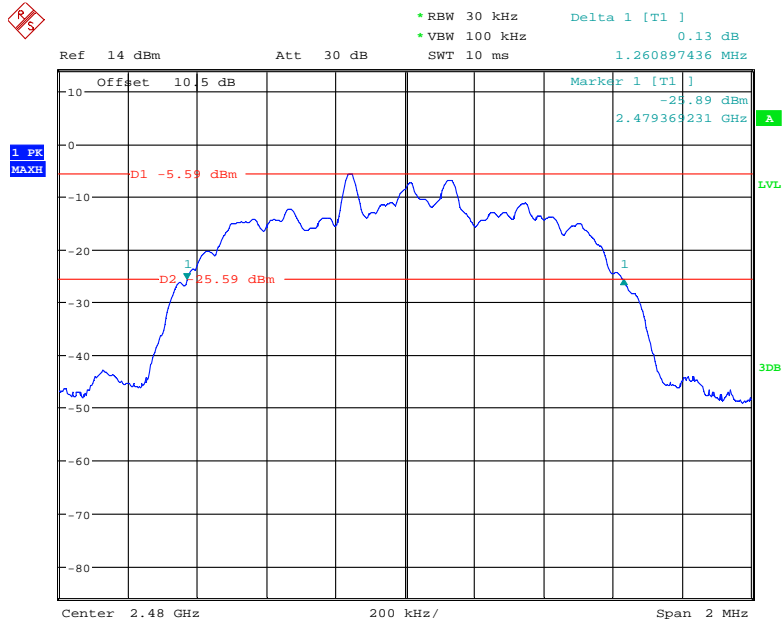

Date: 16.JUL.2020 16:11:48

EDR (8DPSK): Low Channel

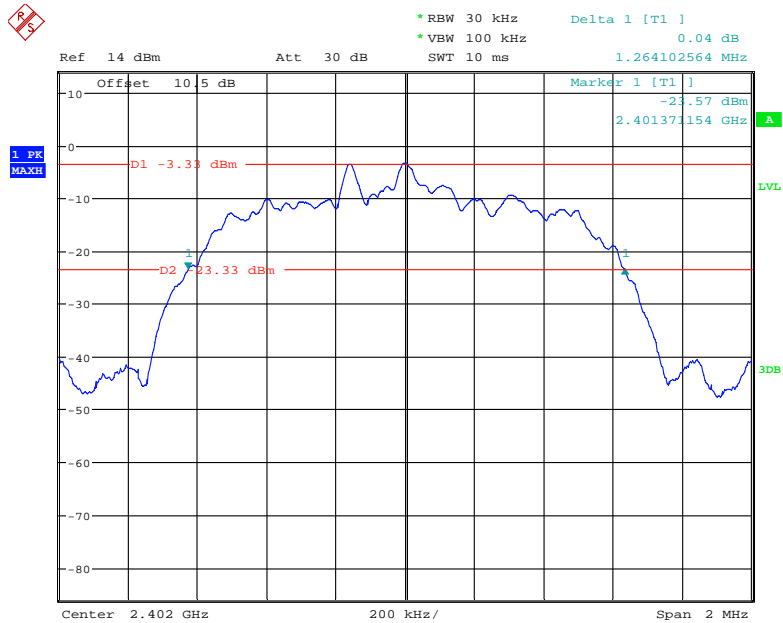

Date: 16.JUL.2020 16:20:19

EDR (8DPSK): Middle Channel

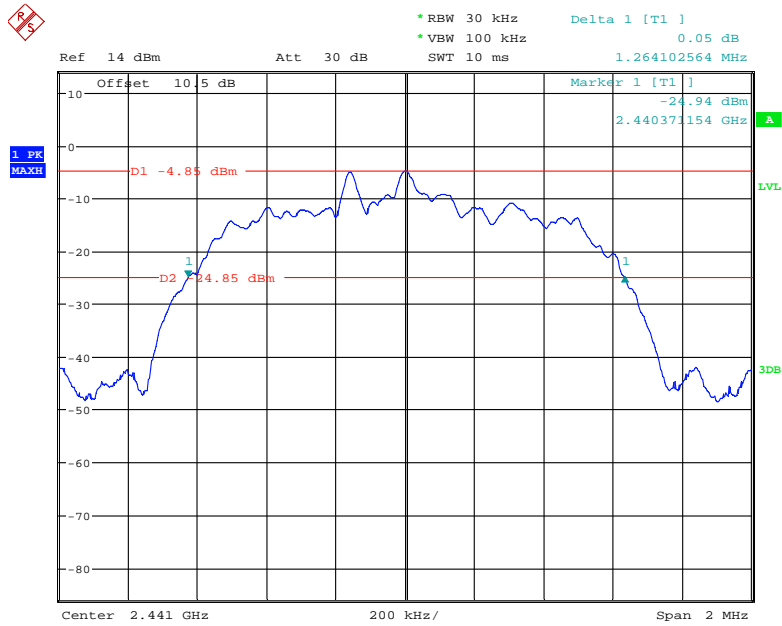

Date: 16.JUL.2020 16:16:46

EDR (8DPSK): High Channel

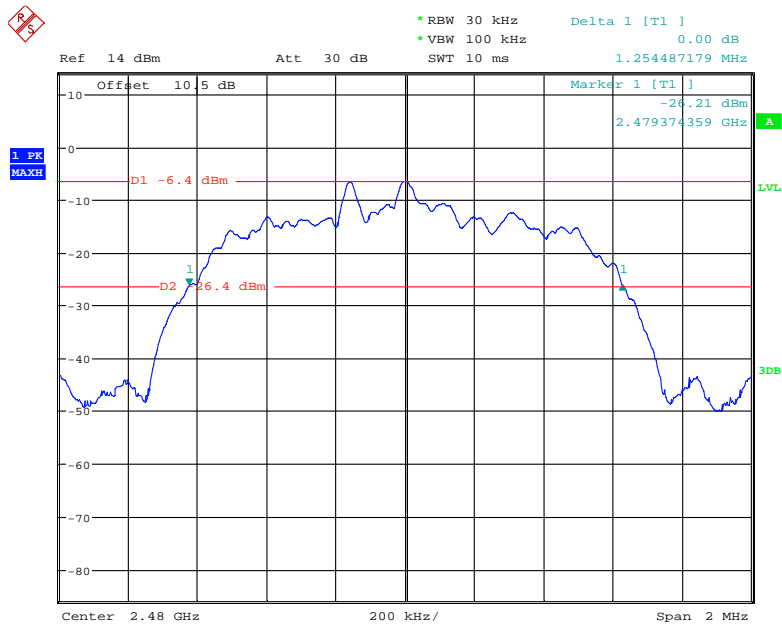

Date: 16.JUL.2020 16:14:01

FCC §15.247(a) (1) (iii)-QUANTITY OF HOPPING CHANNEL TEST

Applicable Standard

Frequency hopping systems in the 2400–2483.5 MHz band shall use at least 15 channels. The average time of occupancy on any channel shall not be greater than 0.4 seconds within a period of 0.4 seconds multiplied by the number of hopping channels employed. Frequency hopping systems may avoid or suppress transmissions on a particular hopping frequency provided that a minimum of 15 channels are used.

Test Procedure

1. Check the calibration of the measuring instrument (SA) using either an internal calibrator or a known signal from an external generator.
2. Set the EUT in hopping mode from first channel to last.
3. By using the max-hold function record the quantity of the channel.

Test Data

Environmental Conditions

Temperature:	24 °C
Relative Humidity:	50 %
ATM Pressure:	101.0 kPa

The testing was performed by Blaker Zhang on 2020-07-16.

EUT operation mode: Transmitting

Test Result: Compliance. Please refer to following table and plots.

Mode	Frequency Range (MHz)	Number of Hopping Channel (CH)	Limit (CH)
BDR (GFSK)	2400-2483.5	79	≥15
EDR (π/4-DQPSK)	2400-2483.5	79	≥15
EDR (8DPSK)	2400-2483.5	79	≥15

BDR (GFSK): Number of Hopping Channels

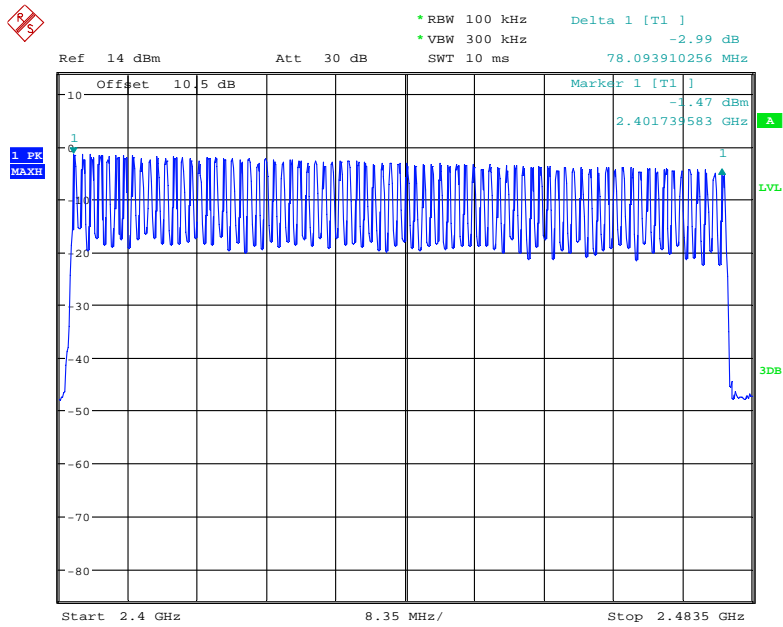

Date: 16.JUL.2020 16:40:27

EDR ($\pi/4$ -DQPSK): Number of Hopping Channels

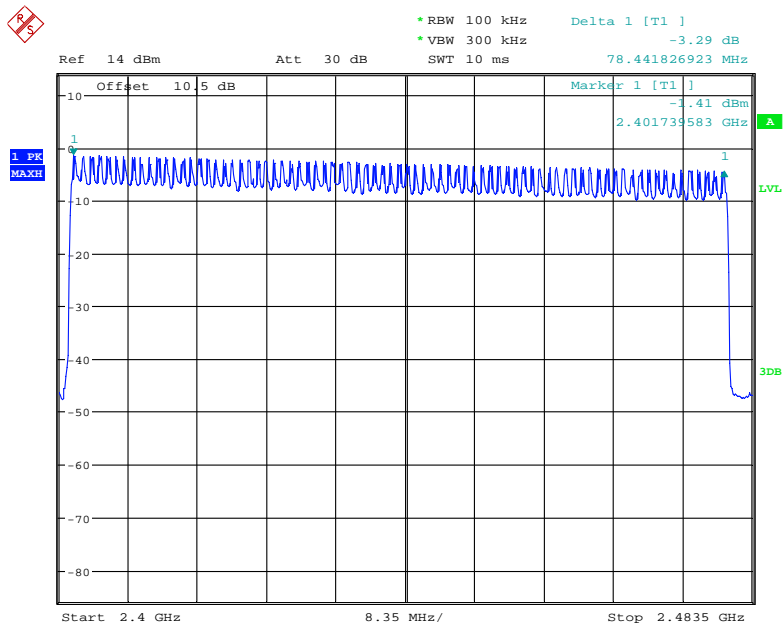

Date: 16.JUL.2020 16:37:51

EDR (8DPSK): Number of Hopping Channels

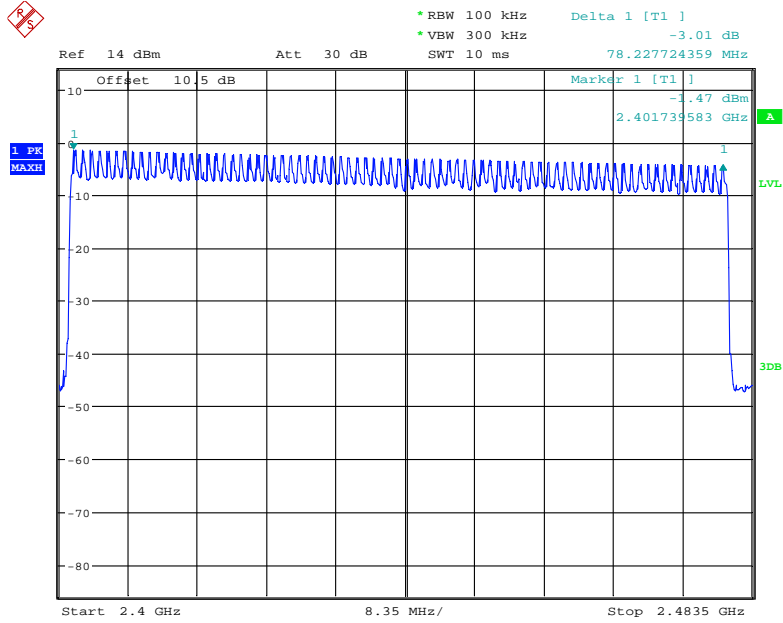

Date: 16.JUL.2020 16:32:14

FCC §15.247(a) (1) (iii) - TIME OF OCCUPANCY (DWELL TIME)**Applicable Standard**

Frequency hopping systems in the 2400-2483.5 MHz shall use at least 15 channels. The average time of occupancy on any channel shall not be greater than 0.4 seconds within a period of 0.4 seconds multiplied by the number of hopping channels employed. Frequency hopping systems may avoid or suppress transmissions on a particular hopping frequency provided that a minimum of 15 channels are used.

Test Procedure

1. The EUT was worked in channel hopping.
2. Set the RBW to: 1MHz.
3. Set the VBW $\geq 3 \times$ RBW.
4. Set the span to 0Hz.
5. Detector = peak.
6. Sweep time = auto couple.
7. Trace mode = max hold.
8. Allow trace to fully stabilize.
9. Recorded the time of single pulses

Test Data**Environmental Conditions**

Temperature:	24 °C
Relative Humidity:	50 %
ATM Pressure:	101.0 kPa

The testing was performed by Blaker Zhang from 2020-07-17 to 2020-07-21.

EUT operation mode: Transmitting

Test Result: Compliance. Please refer to following table and plots.

Test Mode	Channel	Pulse Time (ms)	Total Hops	Period Time (s)	Dwell Time (ms)	Limit (ms)	Result
Test mode: BDR mode(GFSK)							
DH 1	Hop	0.410	300	31.6	123.00	400	Pass
DH 3	Hop	1.685	120	31.6	202.20	400	Pass
DH 5	Hop	2.944	100	31.6	294.40	400	Pass
Test mode: EDR mode($\pi/4$ -DQPSK)							
2DH 1	Hop	0.416	300	31.6	124.80	400	Pass
2DH 3	Hop	1.689	170	31.6	287.13	400	Pass
2DH 5	Hop	2.973	110	31.6	327.03	400	Pass
Test mode: EDR mode(8 DPSK)							
3DH 1	Hop	0.421	320	31.6	134.72	400	Pass
3DH 3	Hop	1.692	130	31.6	219.96	400	Pass
3DH 5	Hop	2.941	80	31.6	235.28	400	Pass

Note 1: A period time=0.4*79=31.6(S), Dwell Time= Pulse Time* Total Hops

Note 2: Total hops =Hopping Number in 3.16s*10

Note 3: Hopping Number in 3.16s = Total of highest signals in 3.16s (Second high signals were other channel)

Pulse time, Middle Channel, DH1

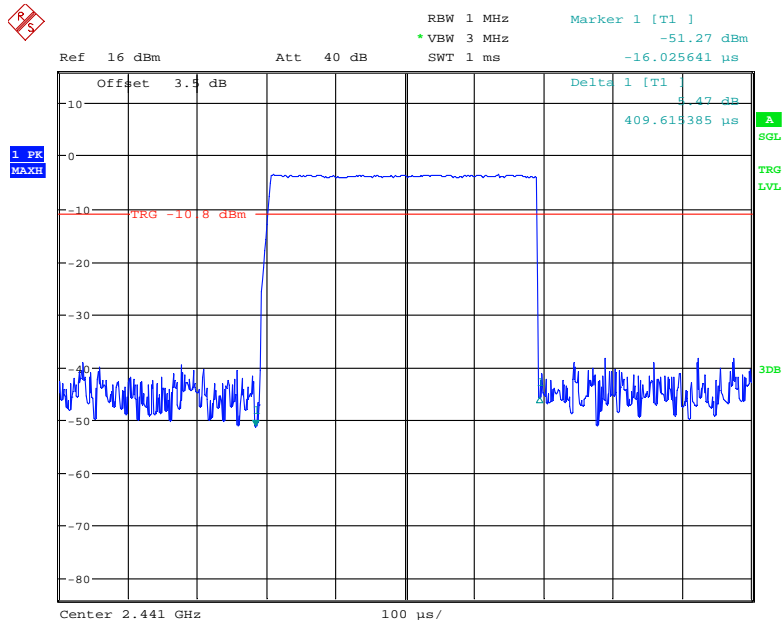

Date: 17.JUL.2020 10:04:01

Hopping Number in 3.16s

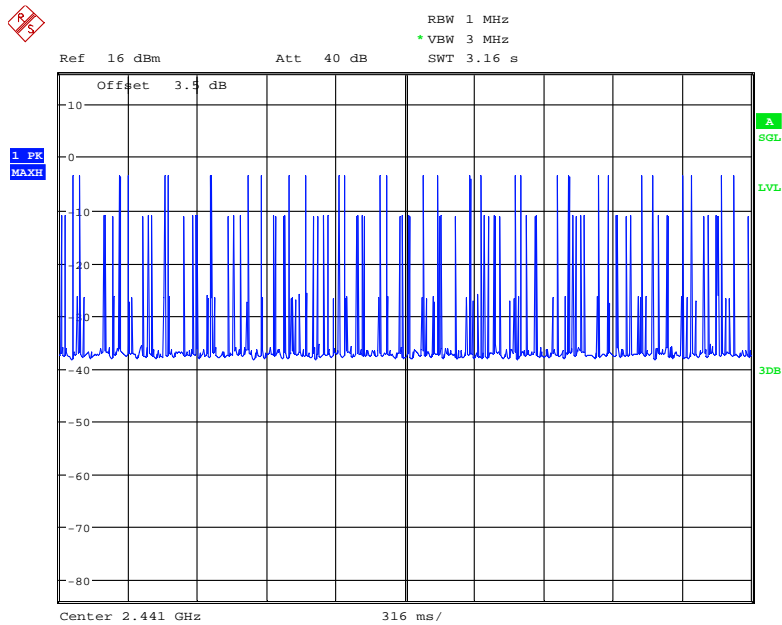

Date: 17.JUL.2020 10:04:53

Pulse time, Middle Channel, DH3

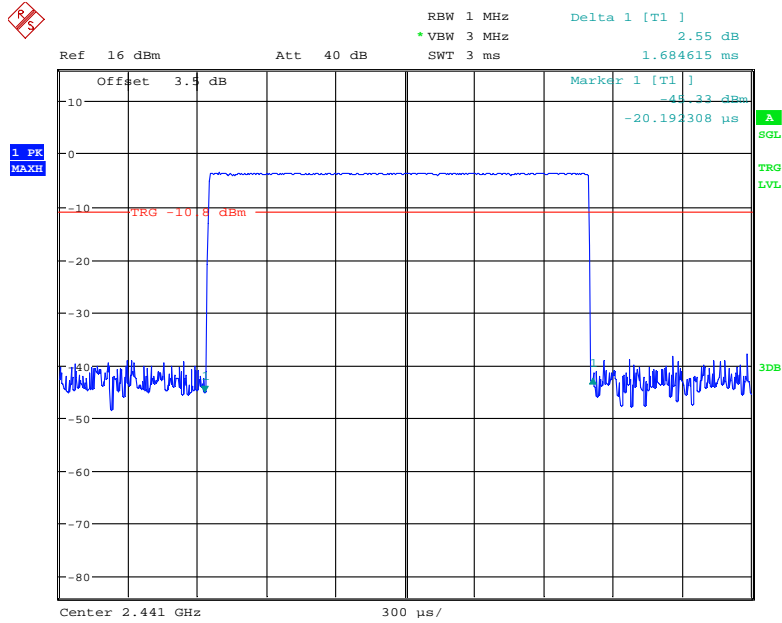

Date: 17.JUL.2020 10:11:07

Hopping Number in 3.16s

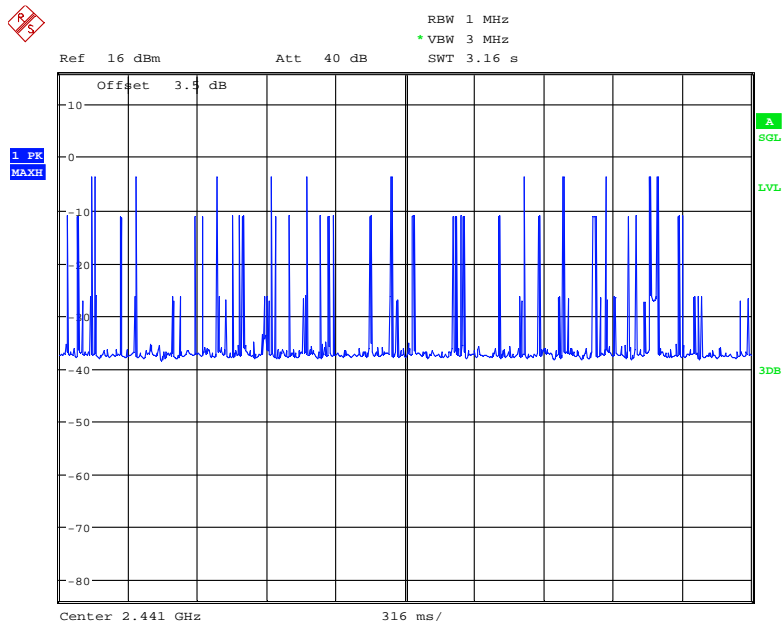

Date: 17.JUL.2020 10:06:01

Pulse time, Middle Channel, DH5

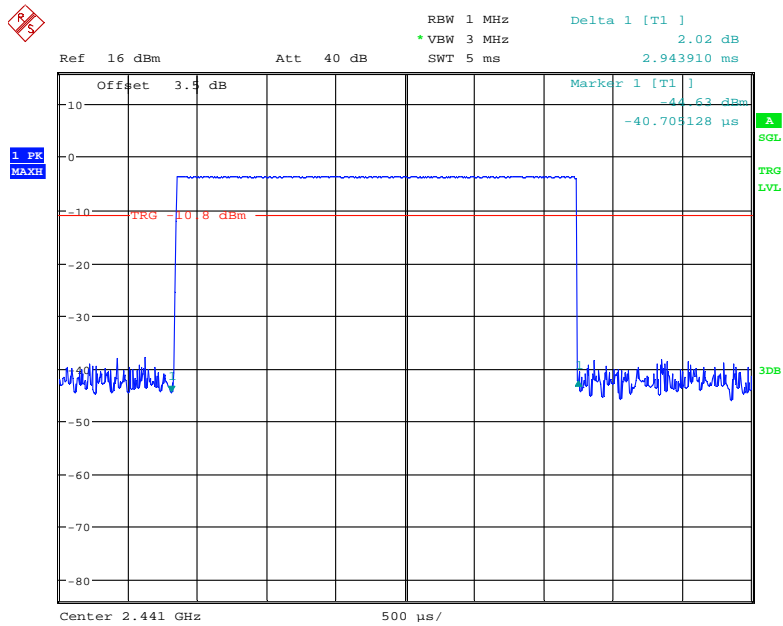

Date: 17.JUL.2020 10:09:18

Hopping Number in 3.16s

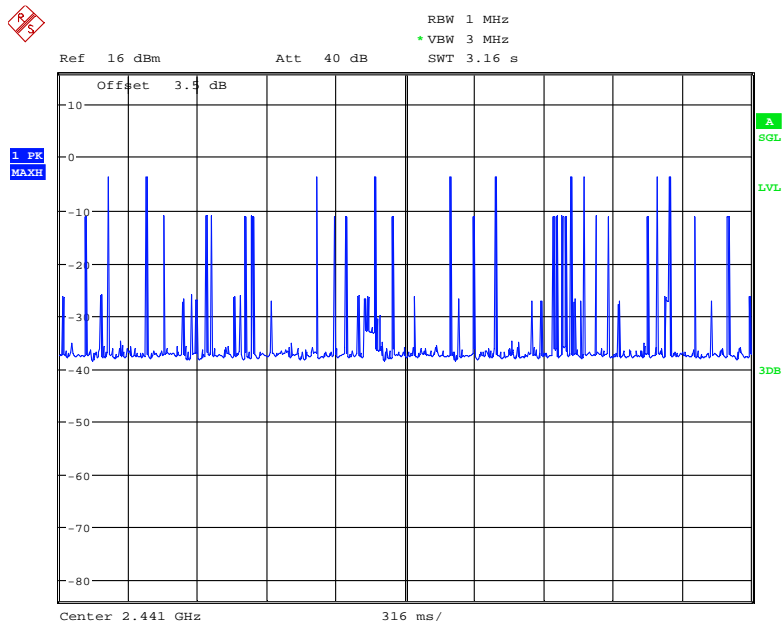

Date: 17.JUL.2020 10:06:59

Pulse time, Middle Channel, 2DH1

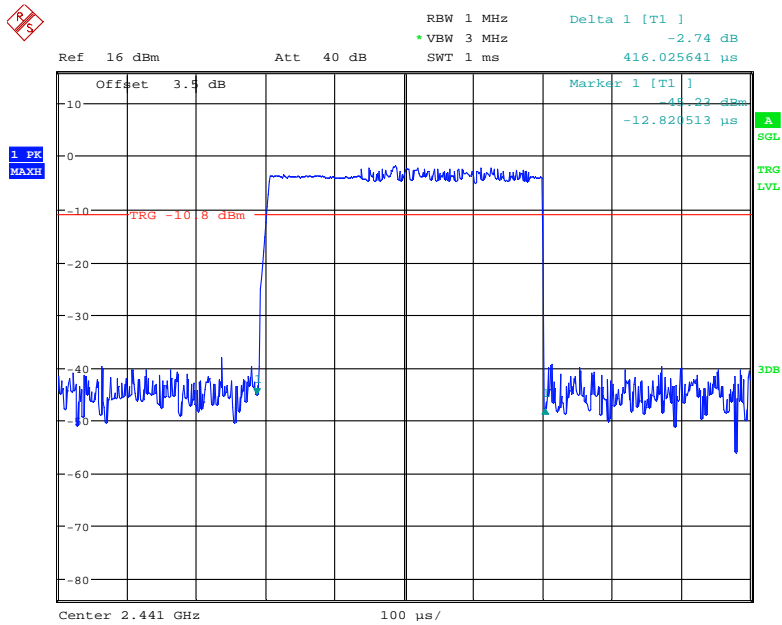

Date: 17.JUL.2020 10:02:32

Hopping Number in 3.16s

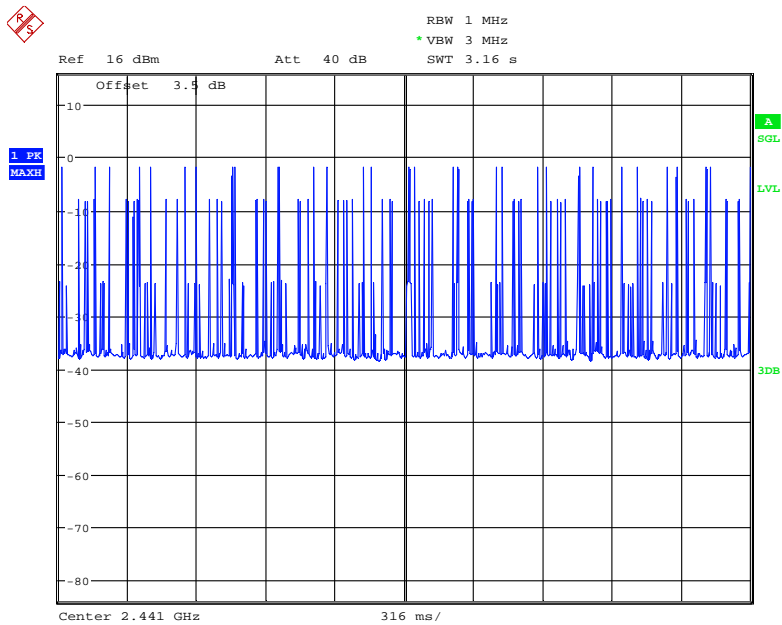

Date: 17.JUL.2020 10:00:47

Pulse time, Middle Channel, 2DH3

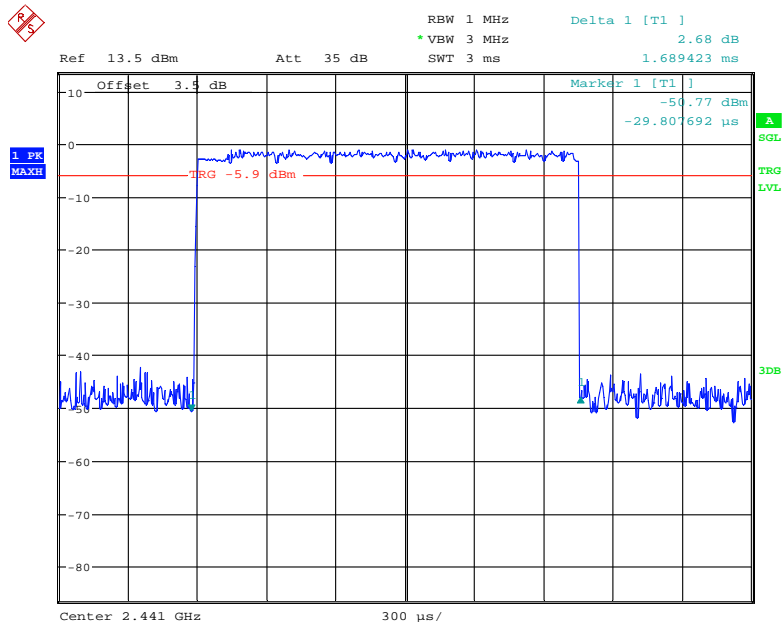

Date: 21.JUL.2020 17:01:00

Hopping Number in 3.16s

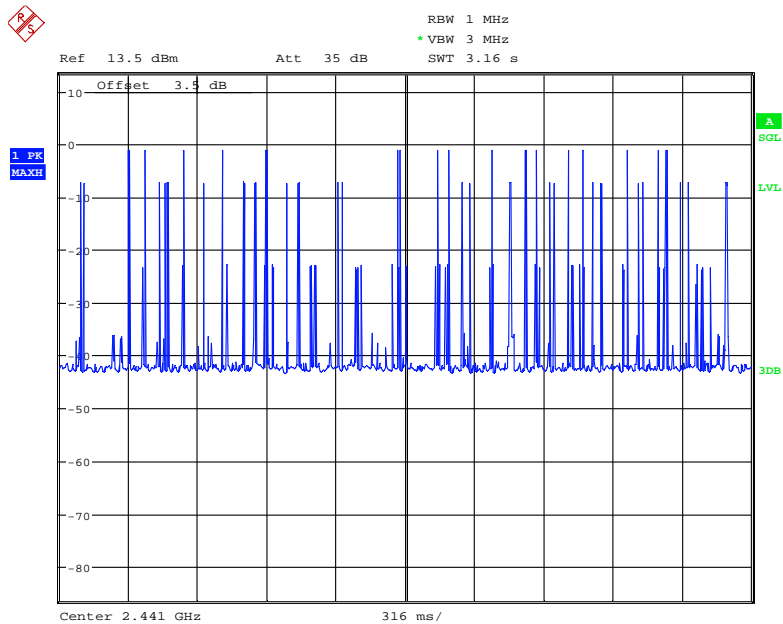

Date: 21.JUL.2020 17:02:20

Pulse time, Middle Channel, 2DH5

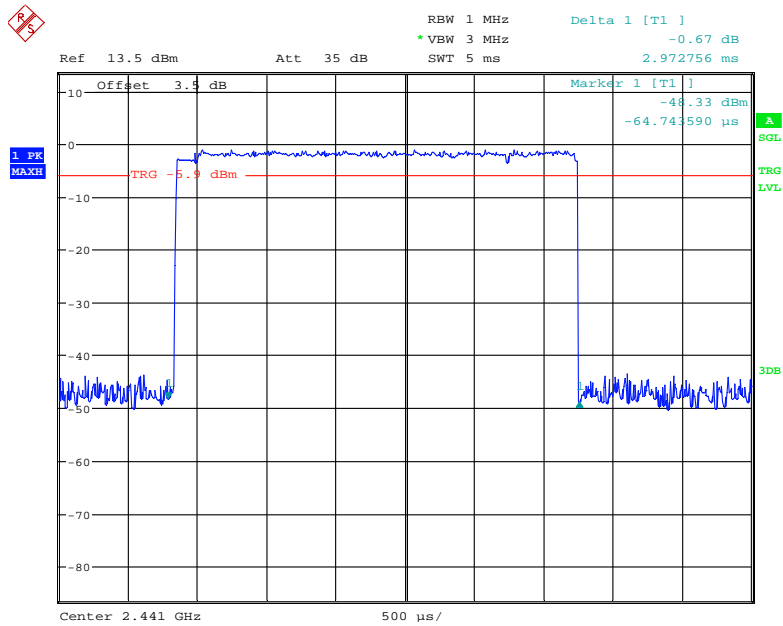

Date: 21.JUL.2020 17:07:45

Hopping Number in 3.16s

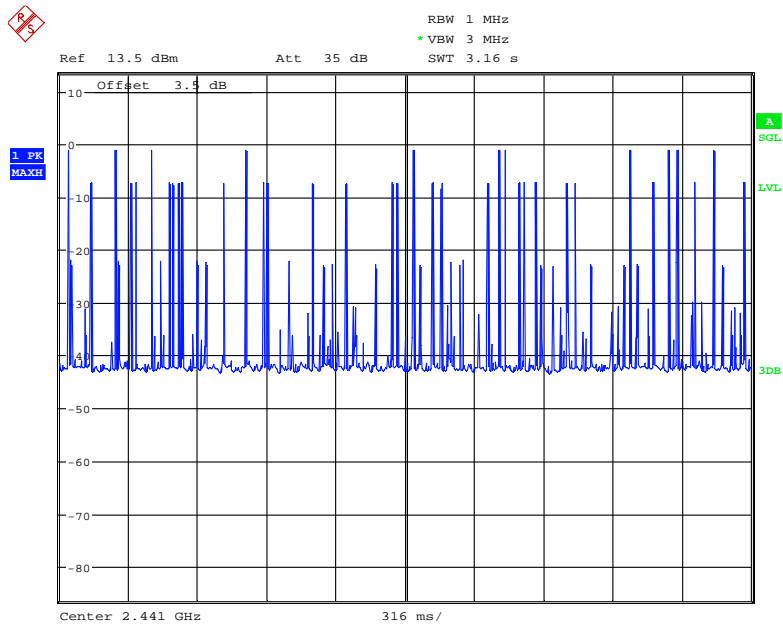

Date: 21.JUL.2020 17:06:21

Pulse time, Middle Channel, 3DH1

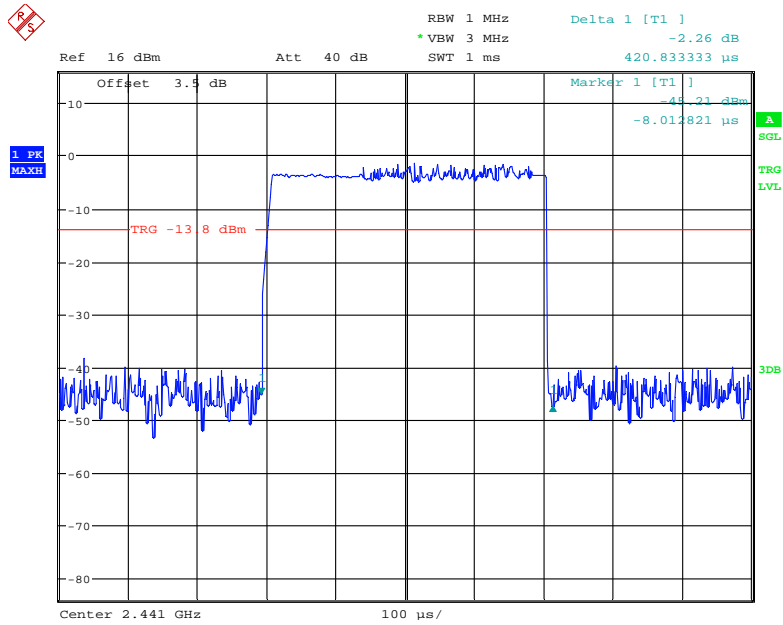

Date: 17.JUL.2020 09:36:16

Hopping Number in 3.16s

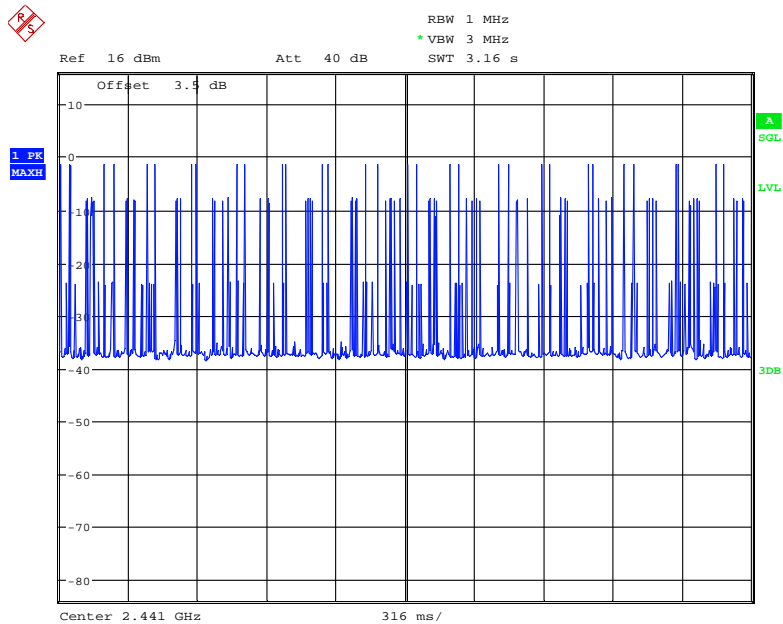

Date: 17.JUL.2020 09:38:39

Pulse time, Middle Channel, 3DH3

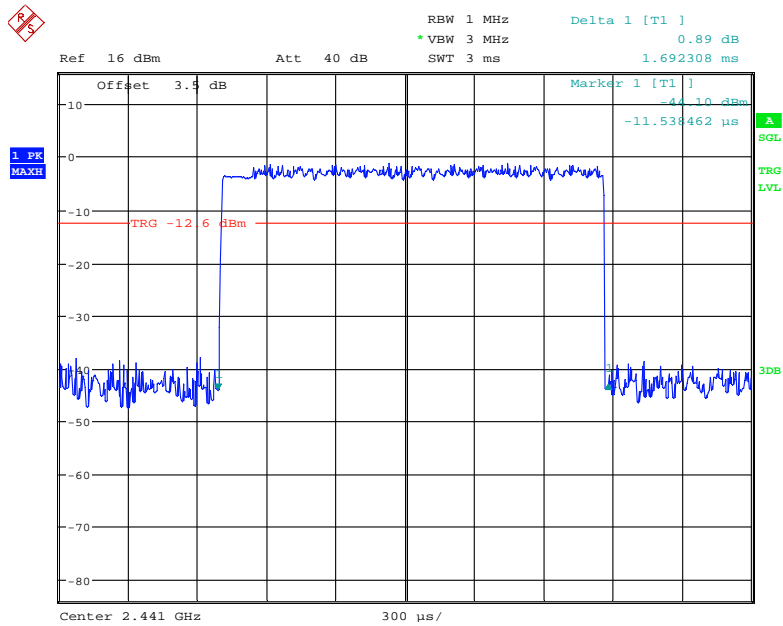

Date: 17.JUL.2020 09:43:40

Hopping Number in 3.16s

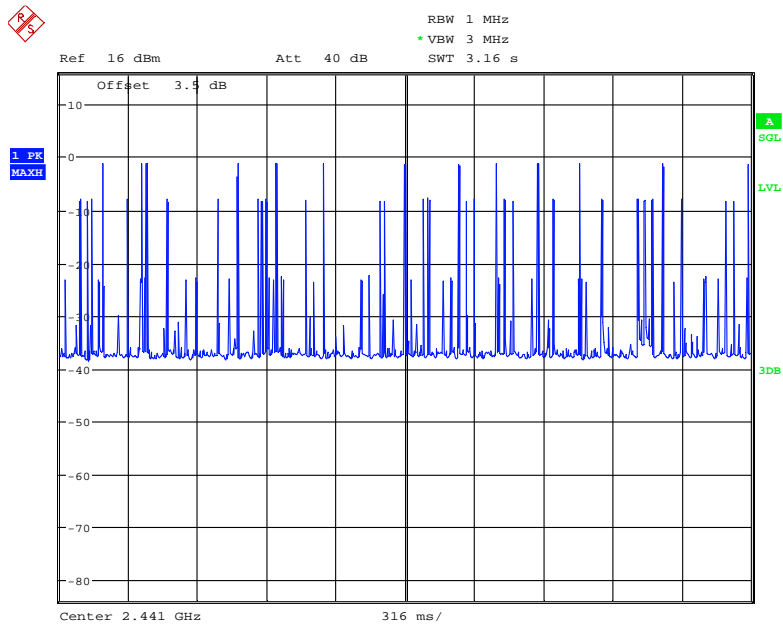

Date: 17.JUL.2020 09:40:14

Pulse time, Middle Channel, 3DH5

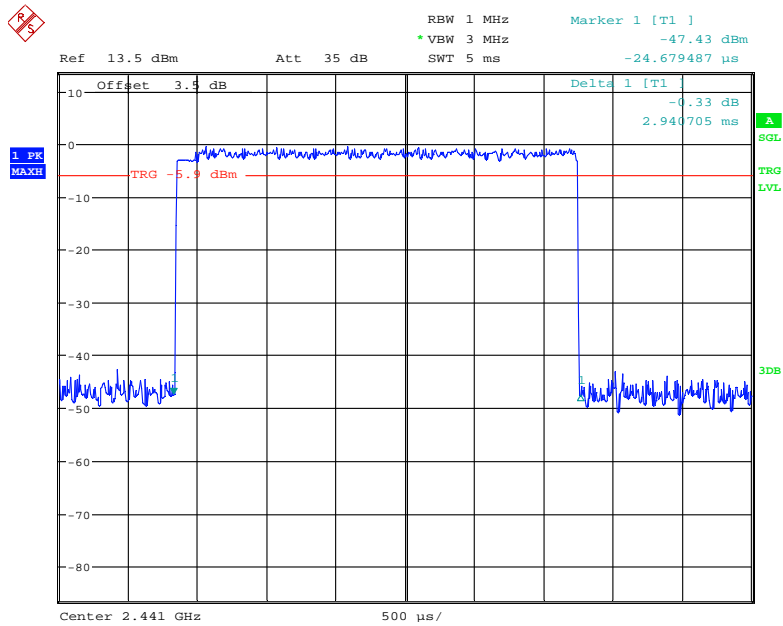

Date: 21.JUL.2020 17:09:15

Hopping Number in 3.16s

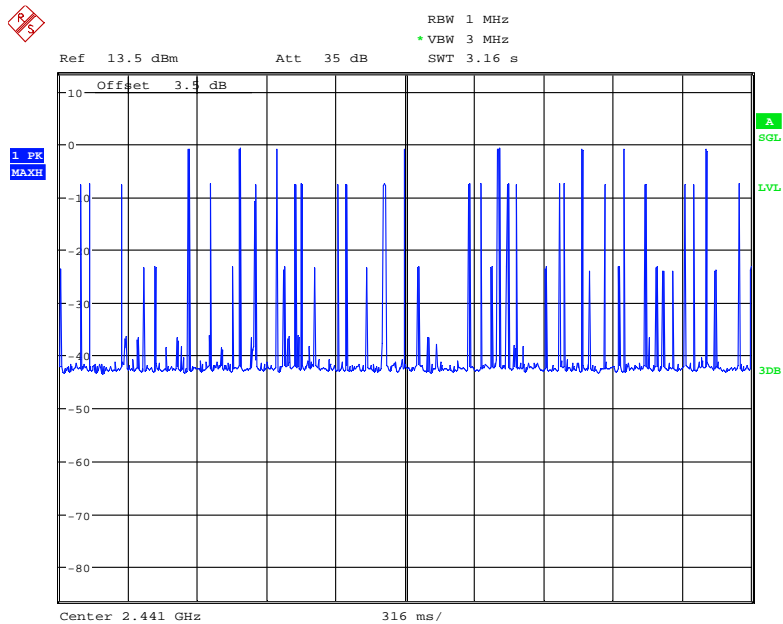

Date: 21.JUL.2020 17:15:25

FCC §15.247(b) (1) - PEAK OUTPUT POWER MEASUREMENT

Applicable Standard

According to §15.247(b) (1), for frequency hopping systems operating in the 2400–2483.5 MHz band employing at least 75 non-overlapping hopping channels, and all frequency hopping systems in the 5725–5850 MHz band: 1 watt. And for all other frequency hopping systems in the 2400–2483.5 MHz band: 0.125 watts.

Test Procedure

1. Place the EUT on a bench and set in transmitting mode.
2. Remove the antenna from the EUT and then connect a low loss RF cable from the antenna port to one test equipment.
3. Add a correction factor to the display.

Test Data

Environmental Conditions

Temperature:	24 °C
Relative Humidity:	50 %
ATM Pressure:	101.0 kPa

The testing was performed by Blaker Zhang from 2020-07-17.

EUT operation mode: Transmitting

Test Result: Compliance. Please refer to following table and plots.

Mode	Channel	Frequency (MHz)	Peak Output Power	Limit (dBm)
			(dBm)	
BDR (GFSK)	Low	2402	-1.41	20.97
	Middle	2441	-2.79	20.97
	High	2480	-4.10	20.97
EDR ($\pi/4$-DQPSK)	Low	2402	0.60	20.97
	Middle	2441	-2.47	20.97
	High	2480	-2.27	20.97
EDR (8DPSK)	Low	2402	1.02	20.97
	Middle	2441	-2.44	20.97
	High	2480	-1.81	20.97

FCC §15.247(d) - BAND EDGES TESTING

Applicable Standard

In any 100 kHz bandwidth outside the frequency band in which the spread spectrum or digitally modulated intentional radiator is operating, the radio frequency power that is produced by the intentional radiator shall be at least 20 dB below that in the 100 kHz bandwidth within the band that contains the highest level of the desired power, based on either an RF conducted or a radiated measurement, provided the transmitter demonstrates compliance with the peak conducted power limits. If the transmitter complies with the conducted power limits based on the use of RMS averaging over a time interval, as permitted under paragraph (b)(3) of this section, the attenuation required under this paragraph shall be 30 dB instead of 20 dB. Attenuation below the general limits specified in §15.209(a) is not required. In addition, radiated emissions which fall in the restricted bands, as defined in §15.205(a), must also comply with the radiated emission limits specified in §15.209(a) (see §15.205(c)).

Test Procedure

1. Check the calibration of the measuring instrument using either an internal calibrator or a known signal from an external generator.
2. Remove the antenna from the EUT and then connect to a low loss RF cable from the antenna port to a EMI test receiver, then turn on the EUT and make it operate in transmitting mode. Then set it to Low Channel and High Channel within its operating range, and make sure the instrument is operated in its linear range.
3. Set RBW of spectrum analyzer to 100 kHz with a convenient frequency span including 100 kHz bandwidth from band edge.
4. Measure the highest amplitude appearing on spectral display and set it as a reference level. Plot the graph with marking the highest point and edge frequency.
5. Repeat above procedures until all measured frequencies were complete.

Test Data

Environmental Conditions

Temperature:	24 °C
Relative Humidity:	50 %
ATM Pressure:	101.0 kPa

The testing was performed by Blaker Zhang from 2020-07-16 to 2020-07-21.

EUT operation mode: Transmitting

Test Result: Compliance. Please refer to following table and plots.

BDR (GFSK): Band Edge-Left Side Hopping

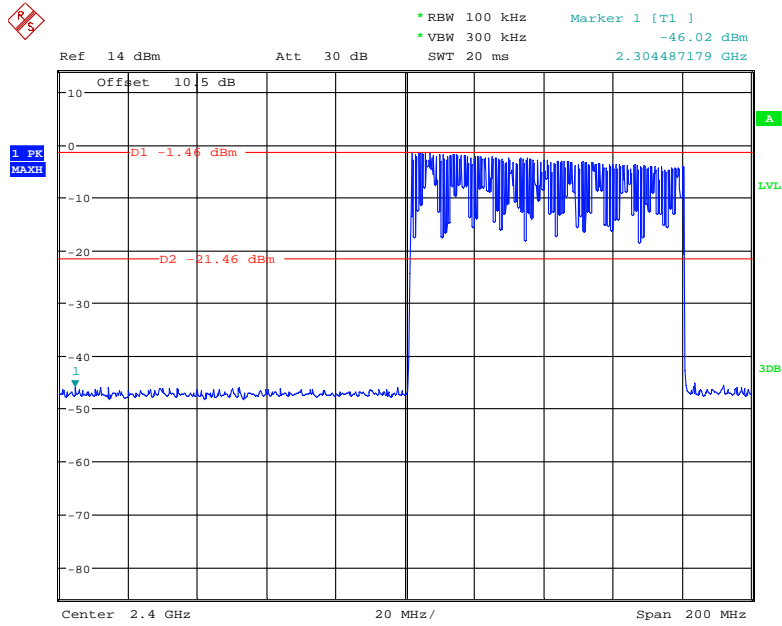

Date: 16.JUL.2020 17:13:37

Single

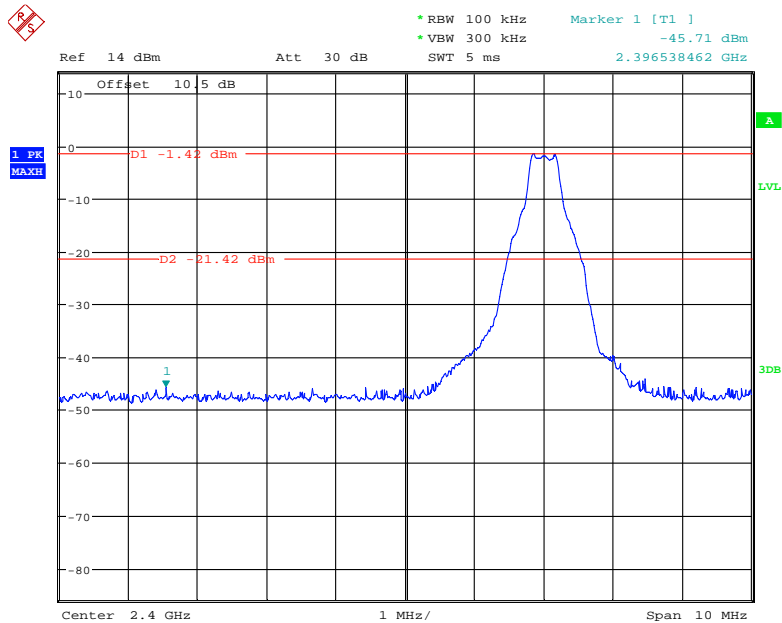

Date: 16.JUL.2020 17:18:46

BDR (GFSK): Band Edge-Right Side Hopping

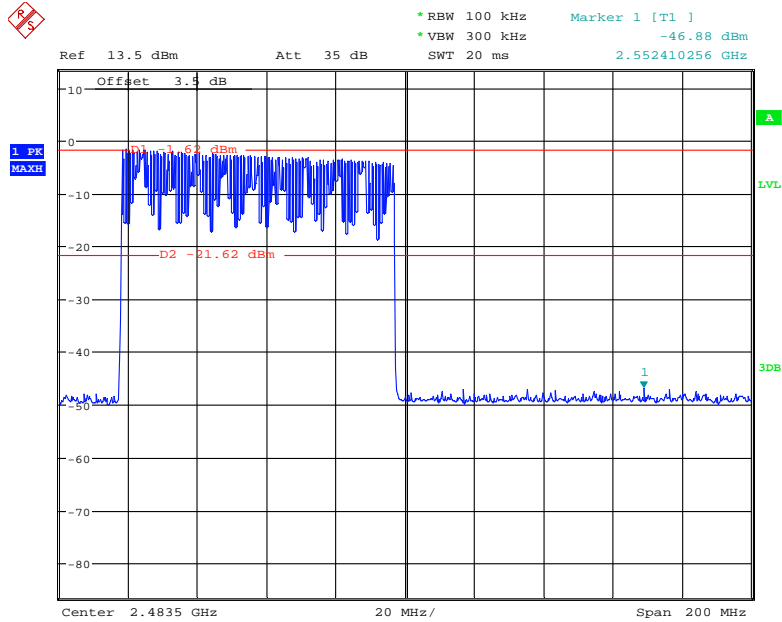

Date: 21.JUL.2020 16:58:06

Single

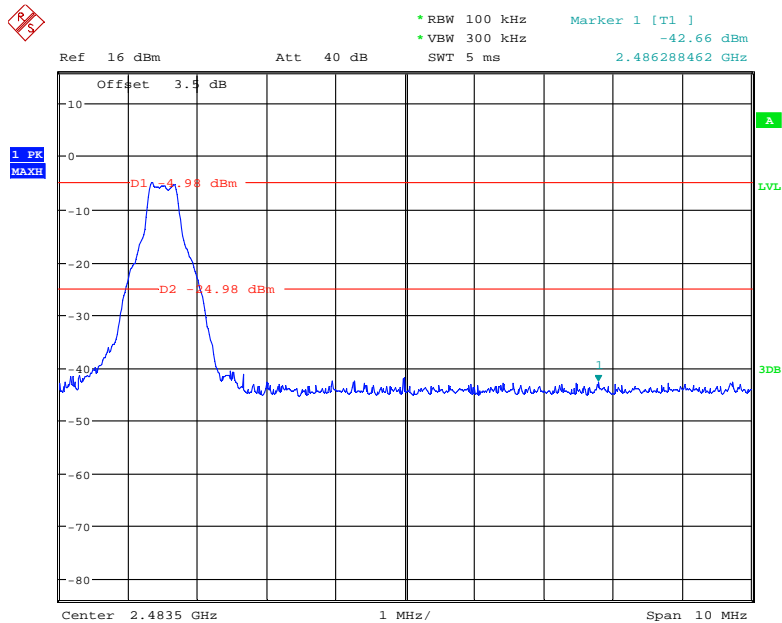

Date: 17.JUL.2020 09:27:58

EDR ($\pi/4$ -DQPSK): Band Edge-Left Side Hopping

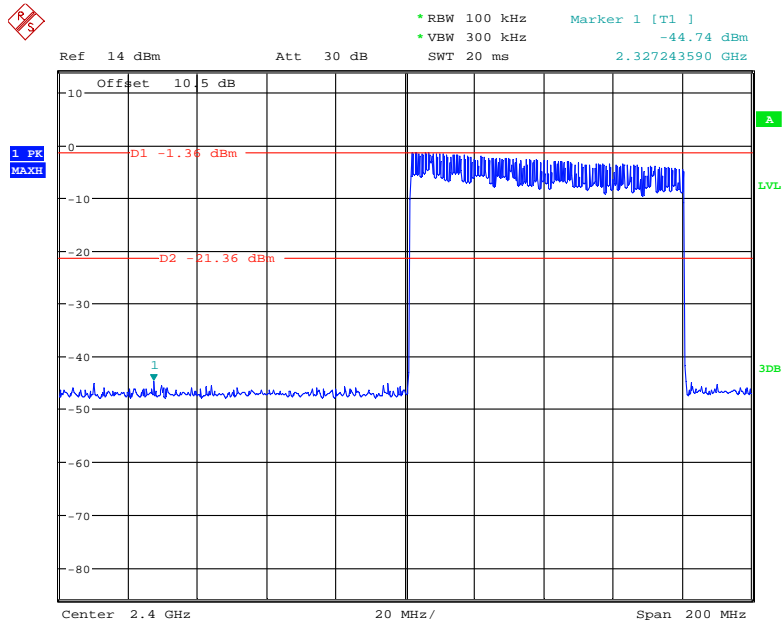

Date: 16.JUL.2020 17:11:08

Single

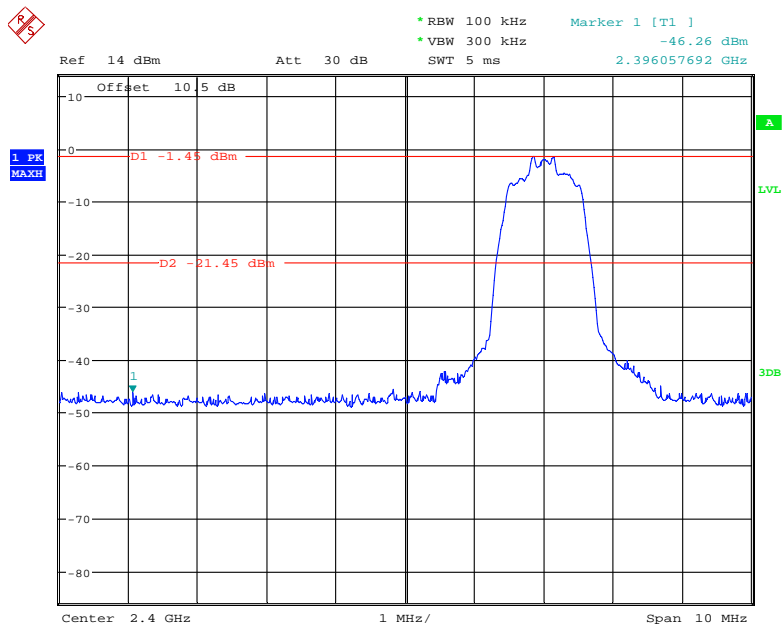

Date: 16.JUL.2020 17:20:43

EDR ($\pi/4$ -DQPSK): Band Edge-Right Side Hopping

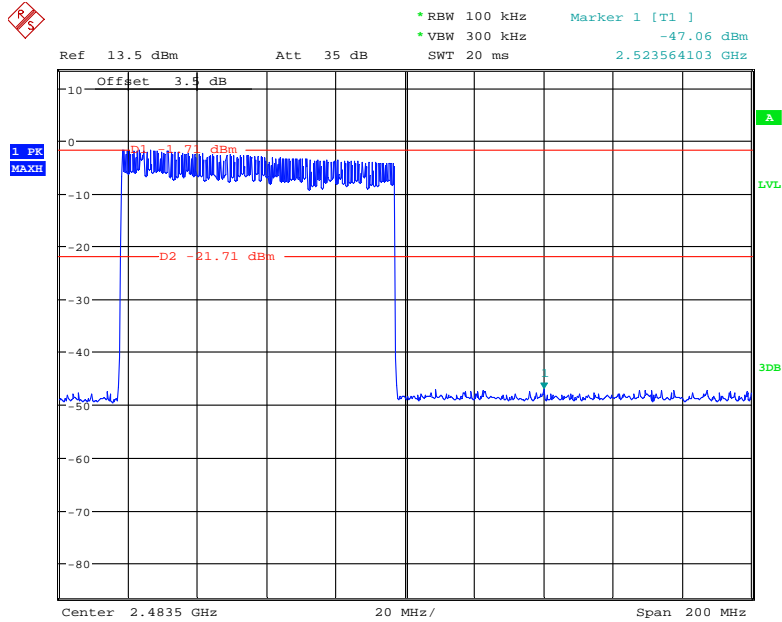

Date: 21.JUL.2020 16:52:25

Single

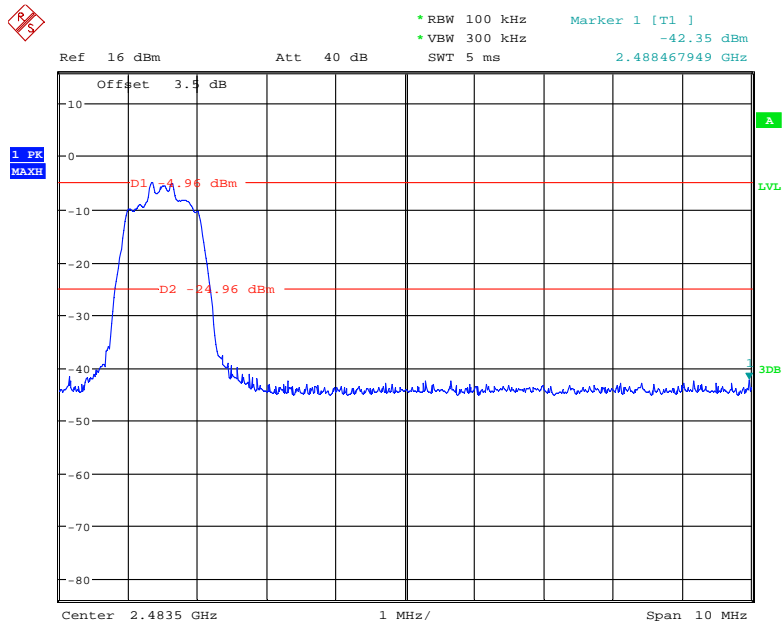

Date: 17.JUL.2020 09:30:08

EDR (8DPSK): Band Edge-Left Side Hopping

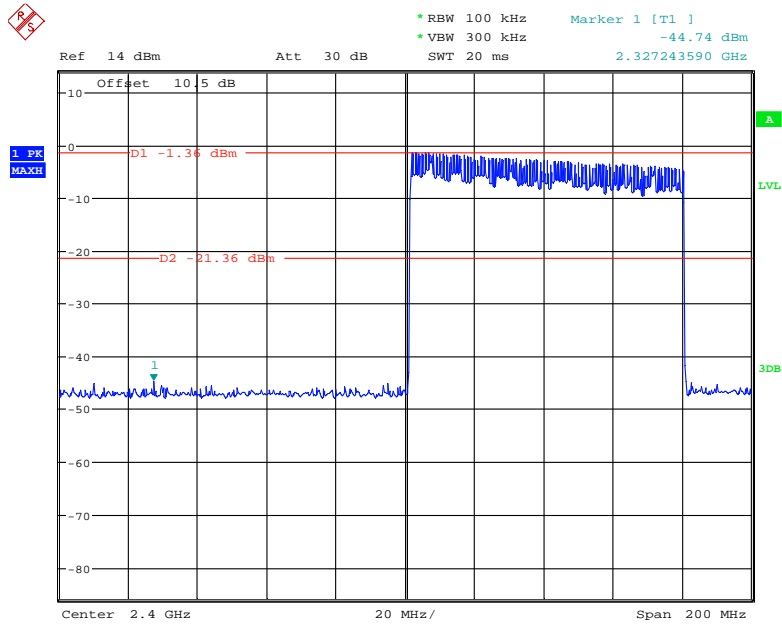

Date: 16.JUL.2020 17:11:08

Single

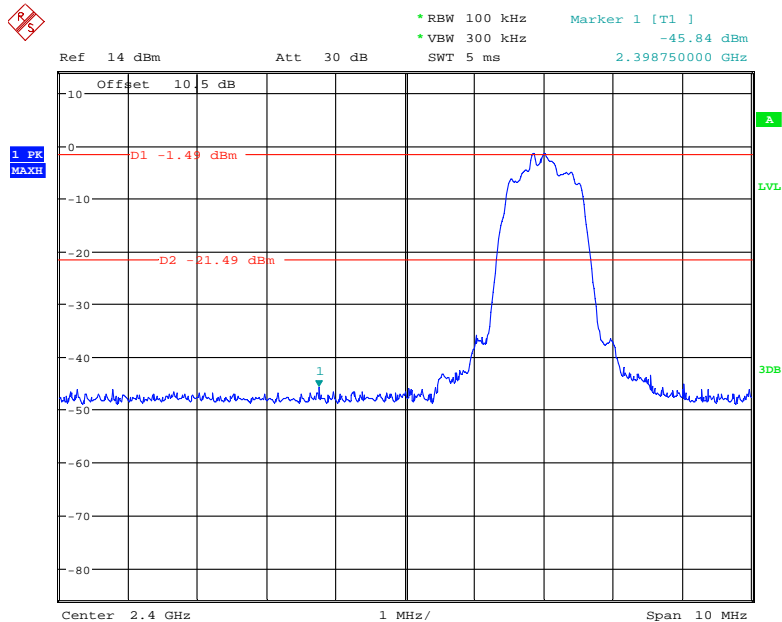

Date: 16.JUL.2020 17:21:52

EDR (8DPSK): Band Edge-Right Side

Hopping

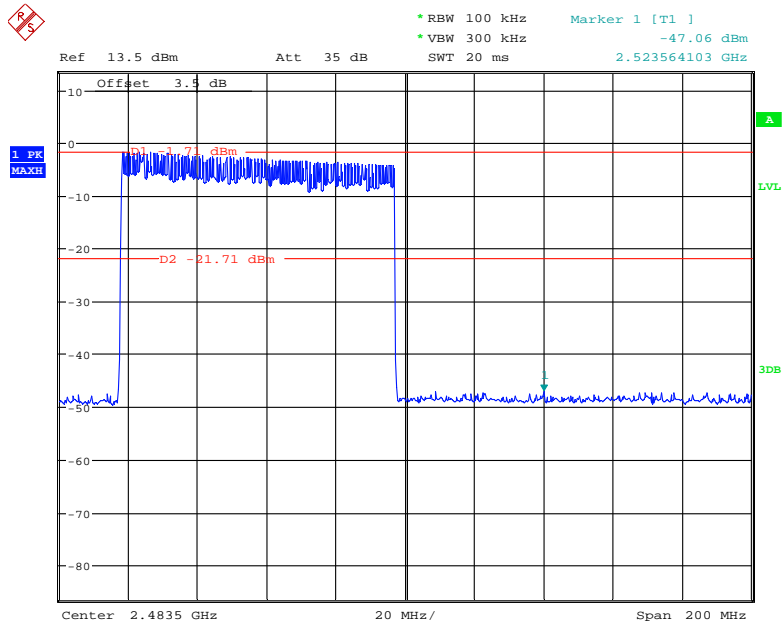

Date: 21.JUL.2020 16:52:25

Single

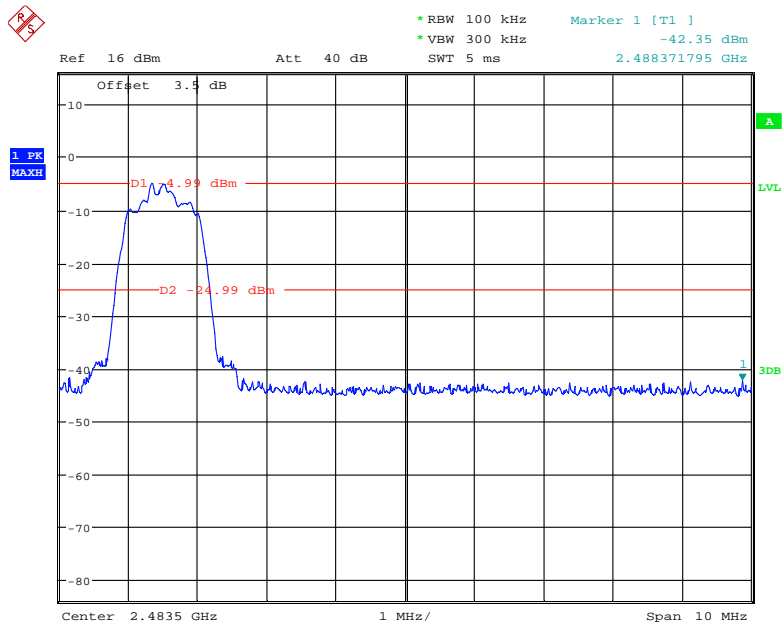

Date: 17.JUL.2020 09:32:47

******* END OF REPORT *******