



TB-01 Specification

Version V1.0

Copyright ©2019

Disclaimer and Copyright Notice

The information in this article, including URL addresses for reference, is subject to change without notice.

This document is provided "as is" without warranty of any kind, including any warranty of merchantability, fitness for a particular purpose, or non-infringement, and any warranty of any proposal, specification, or sample mentioned elsewhere. No liability is assumed in this document, including any infringement of any patent rights arising out of the use of the information in this document. No license is granted by estoppel or otherwise in this document, either express or implied.

The test data obtained in this article are all obtained from the testing performed by Anxinke Labs. Actual results may vary slightly.

The Bluetooth Alliance member logo is owned by the Bluetooth Alliance.

All trademark names, trademarks and registered trademarks mentioned in this article are the property of their respective owners and are hereby declared.

The final interpretation right belongs to Shenzhen Anxinke Technology Co., Ltd.

Pay attention

The contents of this manual may be changed due to product version upgrades or other reasons. Shenzhen Anxinke Technology Co., Ltd. reserves the right to modify the contents of this manual without any notice or prompt. This manual is only used as a guide. Shenzhen Anxin Ke Technology Co., Ltd. makes every effort to provide accurate information in this manual, but Shenzhen An Xin Ke Technology Co., Ltd. does not ensure that the content of the manual is completely error-free. All statements and information in this manual And recommendations do not constitute any express or implied warranty.

FCC WARNING STATEMENT

Changes or modifications not expressly approved by the party responsible for compliance could void the user's authority to operate the equipment. This equipment has been tested and found to comply with the limits for a Class B digital device, pursuant to Part 15 of the FCC Rules. These limits are designed to provide reasonable protection against harmful interference in a residential installation. This equipment generates uses and can radiate radio frequency energy and, if not installed and used in accordance with the instructions, may cause harmful interference to radio communications. However, there is no guarantee that interference will not occur in a particular installation. If this equipment does cause harmful interference to radio or television reception, which can be determined by turning the equipment off and on, the user is encouraged to try to correct the interference by one or more of the following measures: -- Reorient or relocate the receiving antenna.

- Increase the separation between the equipment and receiver.
- Connect the equipment into an outlet on a circuit different from that to which the receiver is connected.
- Consult the dealer or an experienced radio/TV technician for help.

This device complies with Part 15 of the FCC Rules. Operation is subject to the following two conditions:

- (1) This device may not cause harmful interference, and
- (2) This device must accept any interference received, including interference that may cause undesired operation.

Document development/revision/revocation resume

Version	Date	Revised content	Maker	Approve
V1.0	2019.11.25	First developed	Yiji Xie	

CONTENT

一、 INTRODUCTION.....	错误! 未定义书签。
二、 SPECIFICATION.....	错误! 未定义书签。
三、 DIMENSION.....	错误! 未定义书签。
四、 PIN DEFINITION.....	VIII
五、 SCHEMATIC.....	错误! 未定义书签。
六、 DESIGN GUIDE.....	错误! 未定义书签。
七、 REFLOW PROFILE.....	XIII
八、 PACKAGING.....	错误! 未定义书签。
九、 CONTACT US.....	错误! 未定义书签。

1.INTRODUCTION

The TB-01 intelligent lighting module is a Bluetooth module based on the EP2S12F40 chip and compatible with BT 4.2 low-power Tmall Genie Mesh. This module supports the Bluetooth module directly controlled by Tmall Genie and has a Bluetooth mesh networking function. Peer-to-peer network communication, using Bluetooth broadcast for communication, can ensure timely response in the case of multiple devices. It is mainly used in intelligent light control, which can meet the requirements of low power consumption, low latency, and short-range wireless data communication.

Features

- Can be directly controlled by Tmall Elf without a gateway
- 2.0mm pitch pin vertical solder package
- 2 positive white warm white PWM outputs
- With on-board antenna, no need to design antenna
- Brightness (duty cycle) adjustment range 5% -100%
- Factory default 50% duty cycle for cool and warm colors
- PWM output power 1KHz
- With night light function
- With wall switch to switch color temperature function

LIST 1 Main Parameters

Model Name	TB-01
Size	22.0*14.0*2.0(±0.2)MM
Wireless Standard	Bluetooth V4.2
Frequency Range	2400 ~ 2483.5MHz
Output Power	10dBm
Max Sensitivity	-92dBm
Interface	PWM
Work Temperature	-20℃ ~ 70 ℃
Store Temperature	-40 ℃ ~ 125 ℃ , < 90%RH
Voltage Range	Voltage 2.7V ~ 3.6V, Current ≥ 50mA
Power	Deep Sleep Mode: 0.9uA
	Sleep Mode: 1.9uA
	Mesh Mode: 30mA
Transmission distance	80m ~ 150m

2.SPECIFICATION

Electrical characteristics

Absolute Maximum Rating

Any exceeding the following absolute maximum ratings may cause damage to AB1611

Item	Min	Typical	Max
Voltage	2.7V	3.3V	3.6V
I/O Voltage (VCCIO)	-0.3V	-	3.6V
Work Temperature	-20°C	-	+70°C
Store Temperature	-40°C	-	+125°C

Recommended Operating Conditions

Item	Min	Typical	Max
RF Voltage (VCCRF)	-	1.2V	-

RF Specification

Output Power

Item	Min	Typical	Max
Average Power	8.5dBm	9.5dBm	10dBm

Sensitivity

Item	Min	Typical	Max
Sensitivity	-92dBm	-91dBm	-90dBm

3.DIMENSION

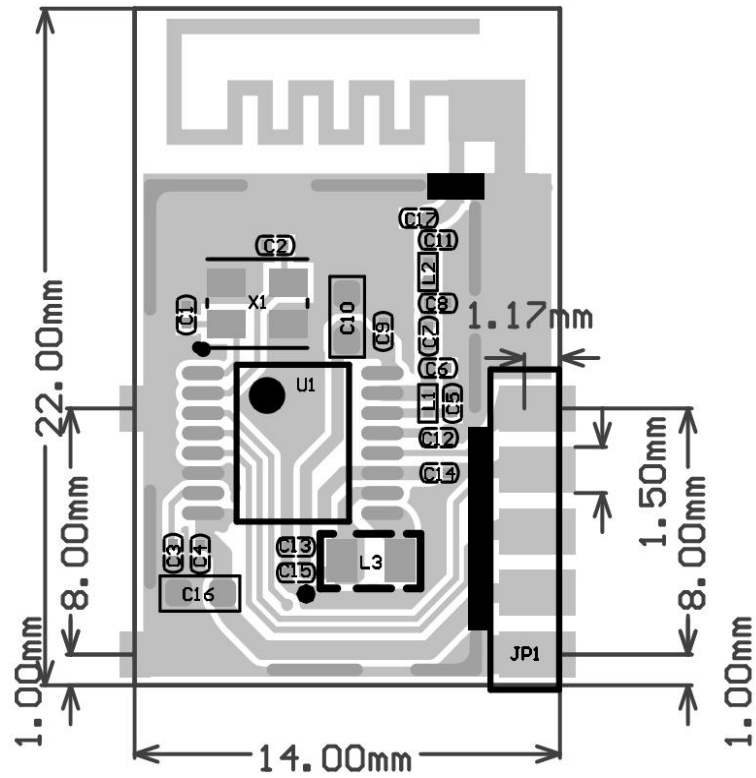
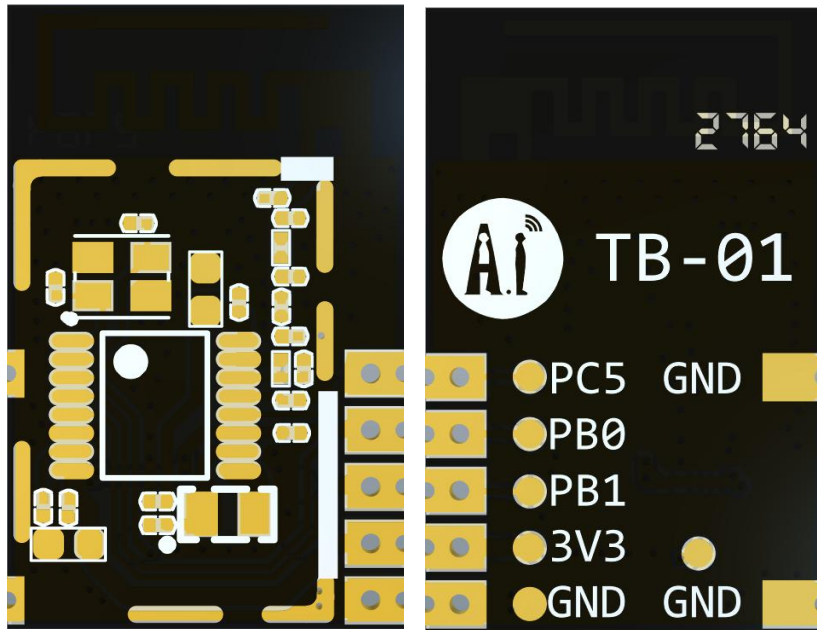

4. PIN DEFINITION

The TB-01 module has a total of 7 interfaces. For example, the pin diagram, the pin function definition table is the interface definition.

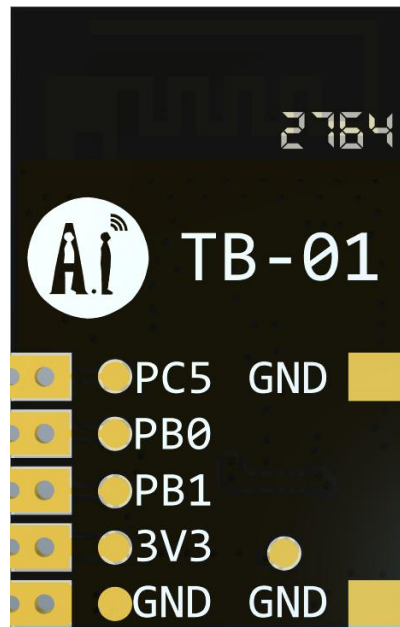

TB-01 Pin diagram

PIN function definition sheet

No.	Item	Function Description
1	GND	Ground
2	3V3	Electricity supply
3	PB1	Positive white PWM output, high effective
4	PB0	Warm white PWM output, high effective
5	PC5	AC power-down detection pin (function can be customized)
6	GND	Ground
7	GND	Ground

5.SCHEMATIC

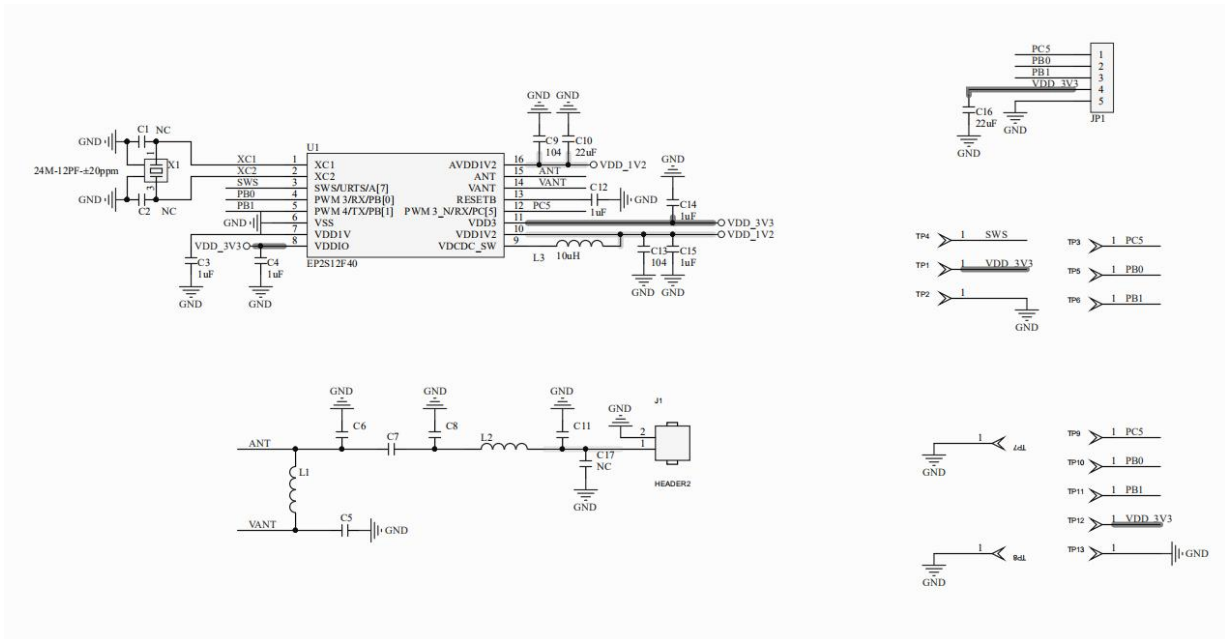

6.DESIGN GUIDE

1、Application circuit

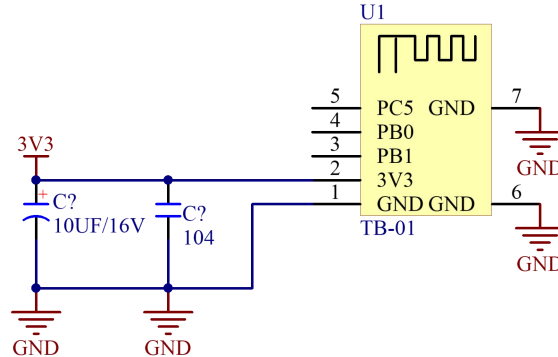

2、Antenna layout requirements

(1) For the installation position on the motherboard, the following two methods are recommended:

Solution 1: Place the module on the edge of the motherboard, and the antenna area extends beyond the edge of the motherboard.

Solution 2: Place the module on the edge of the motherboard, and the edge of the motherboard hollows out an area at the antenna position.

(2) In order to meet the performance of the on-board antenna, it is forbidden to place metal parts around the antenna and keep it away from high-frequency devices.

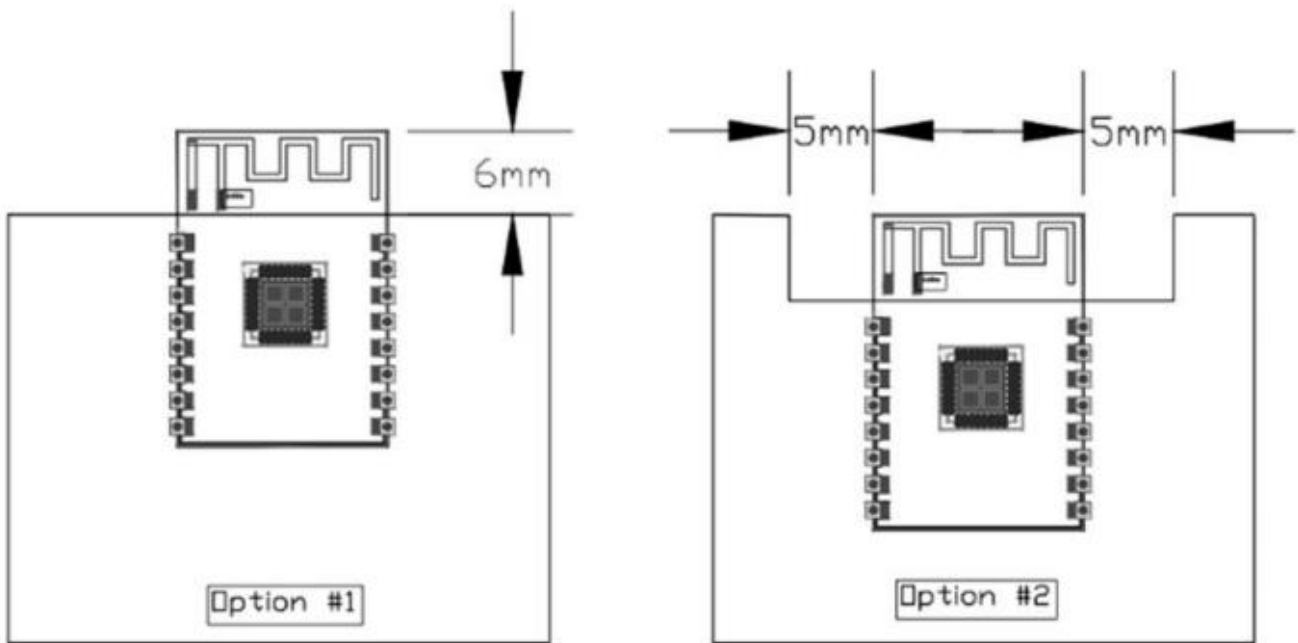

3、Electricity Supply

- (1) Recommended 3.3V voltage, peak current above 50mA
- (2) It is recommended to use LDO power supply; if using DC-DC, it is recommended to control the ripple within 30mV.
- (3) The DC-DC power supply circuit is recommended to reserve the position of the dynamic response capacitor, which can optimize the output ripple when the load changes greatly.
- (4) 3.3V power interface is recommended to add ESD devices.

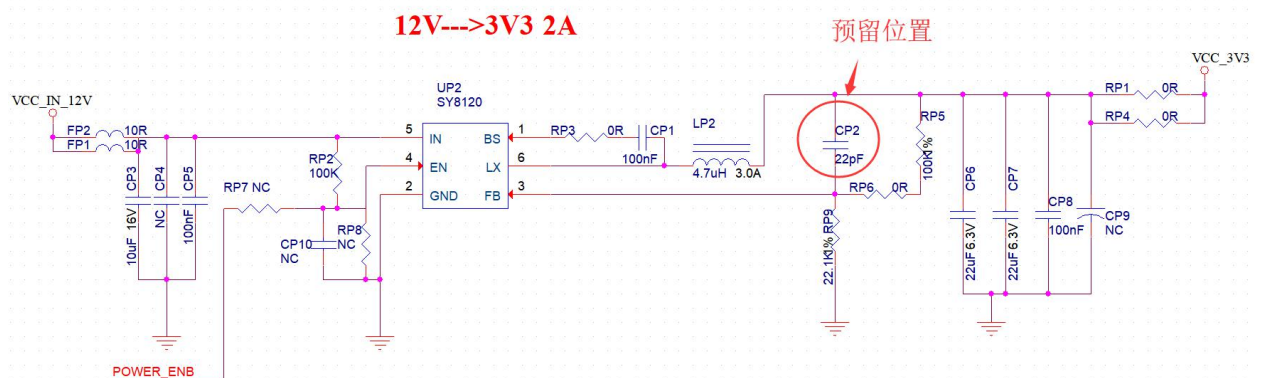

4、PWM Dimming Solution Design Instructions

For lamps that require dimming, you only need to connect the PWM pins of the corresponding color to the control end of the subsequent stage drive circuit; the PWM independently outputs a 100-level adjustable digital signal, and the subsequent stage circuit can be voltage The driving type may be a current driving type.

Connection diagram

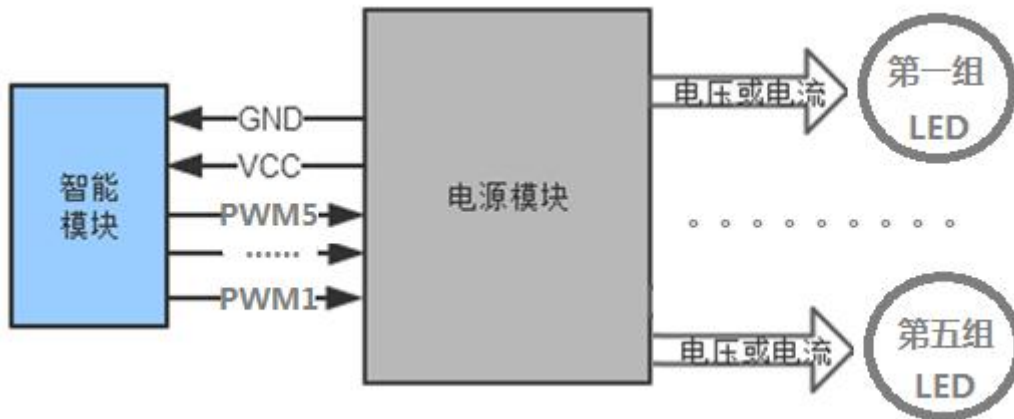

5、LED Drive Reference Design

TB-01 module application only needs 3.3V power supply and simple driving circuit to achieve intelligent light control. Take MOS tube to drive a channel of white light as an example, the design reference is as follows; CW_I is the module's positive white light PWM output , Q1 is MOS tube, WW is LED lamp beads, the other 4 road lamp driving circuit is the same as this road design method.

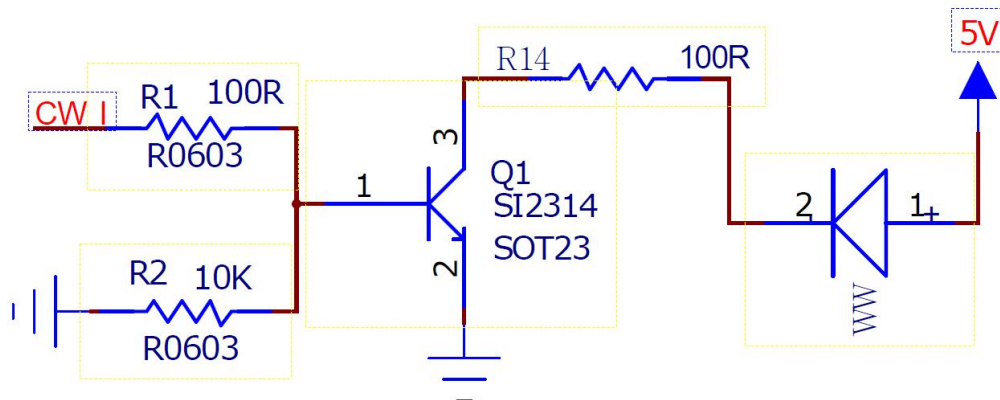

6、Secondary development

The TB-01 module supports users to write their own firmware programs to achieve customized functions.

If you use a Linux machine to develop the firmware, you can refer to the SDK, documentation and source address of Anxin's collation:

https://github.com/Ai-Thinker-Open/Telink_825X_SDK.

If you use Windows development, you can refer to the original SDK provided by the chip manufacturer. Download address:

<http://wiki.telink-semi.cn>

7. REFLOW PROFILE

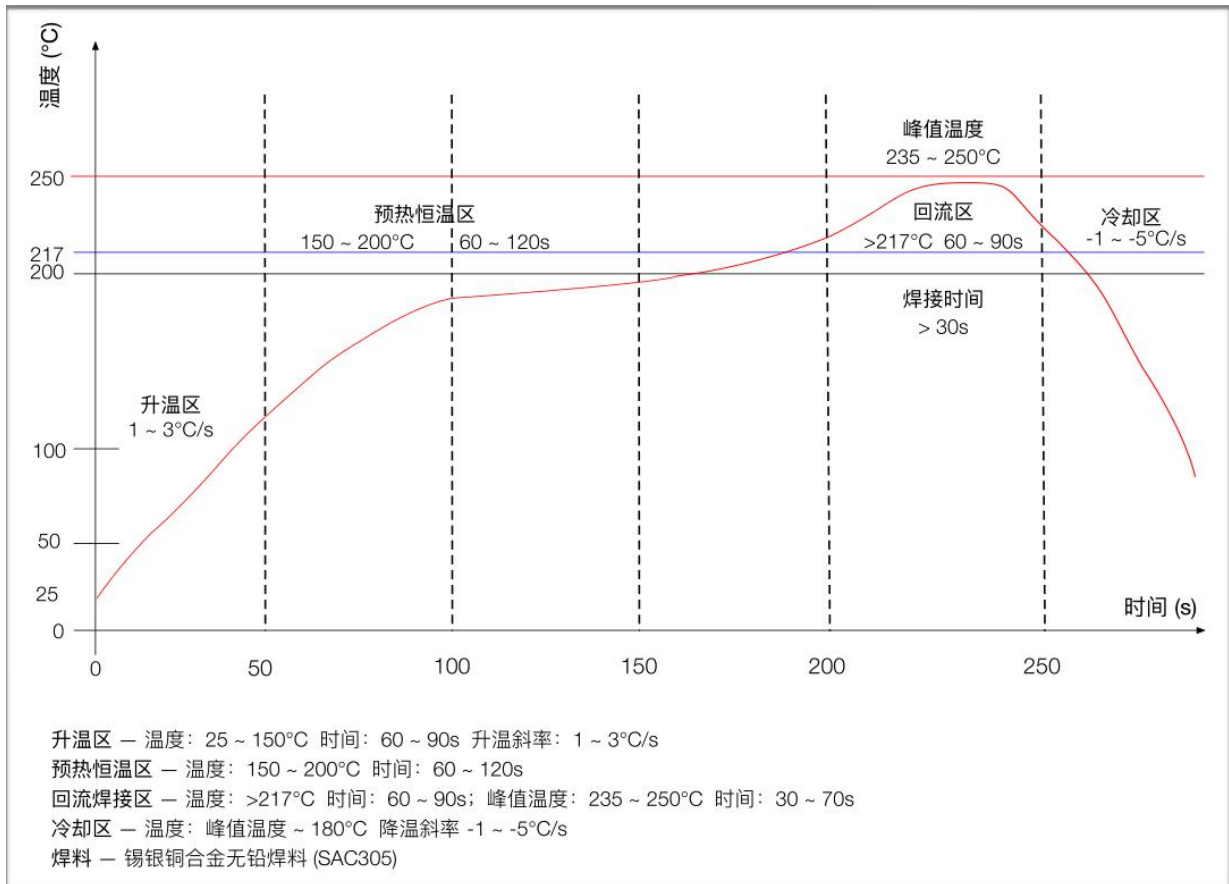

8. PACKAGING

As shown below, the packaging of TB-01 is taping packaging.



9. CONTACT US

Company Website: <https://www.ai-thinker.com>

Development DOCS: <http://docs.aithinker.com>

Official Forum: <http://bbs.ai-thinker.com>

Sample Purchase: <https://anxinke.taobao.com>

Business: sales@aithinker.com

Technical Support: support@aithinker.com

Company Address: 410, Building C, Gufeng Huafeng Smart Innovation Port, Xixiang, Baoan District,
Shenzhen

Tel: 0755-29162996

If the FCC identification number is not visible when the module is installed inside another device, then the outside of the device into which the module is installed must also display a label referring to the enclosed module. This exterior label can use wording such as the following: "Contains Transmitter Module FCC ID: 2AHMR-TB-01 Or Contains FCC ID: 2AHMR-TB-01"

When the module is installed inside another device, the user manual of this device must contain below warning statements:

1.This device complies with Part 15 of the FCC Rules. Operation is subject to the following two conditions:

(1) This device may not cause harmful interference, and

(2) This device must accept any interference received, including interference that may cause undesired operation.

2.Changes or modifications not expressly approved by the party responsible for compliance could void the user's authority to operate the equipment.

The devices must be installed and used in strict accordance with the manufacturer's instructions as described in the user documentation that comes with the product. The host product manufacturer is responsible for compliance to any other FCC rules that apply to the host not covered by the modular transmitter grant of certification. The final host product still requires Part 15 Subpart B compliance testing with the modular transmitter installed. The end user manual shall include all required regulatory information/warning as shown in this manual.