

## Electromagnetic Emission

# FCC MEASUREMENT REPORT

## CERTIFICATION OF COMPLIANCE

### FCC Part 15 Certification Measurement

**PRODUCT** : RADAR DETECTOR  
**MODEL/TYPE NO** : NR-ALP / Proto-type  
**FCC ID** : 2AHMC-NR  
**MULTIPLE MODEL** : -  
**BRAND NAME** : -  
**APPLICANT** : Net Electronics LLC  
2275 West Conuty Line Road, Suite 6-341,  
Jackson, NJ 08527, United States  
Attn.: Thomas Milone / Owner  
**MANUFACTURER** : ATTOWAVE CO., LTD.  
1005, 10F Leader's Tower, 60-15 Gasan-dong,  
Gumchun-gu, Seoul, 153-801 Korea  
**FCC CLASSIFICATION** : Unintentional Radiators  
CRD - Part 15 Radar Detector  
**RULE PART(S)** : FCC Part 15 Subpart B  
**TEST PROCEDURE** : ANSI C63.4-2001 and FCC 02-211  
**TEST REPORT No.** : ETLE160322.0265  
**DATES OF TEST** : March 28, 2016  
**REPORT ISSUE DATE** : April 12, 2016  
**TEST LABORATORY** : ETL Inc. (FCC Designation Number: KR0022)

This RADAR DETECTOR, Model NR-ALP has been tested in accordance with the measurement procedures specified in ANSI C63.4-2001 and FCC 02-211 at the ETL Test Laboratory and has been shown to be complied with the electromagnetic radiated emission limits specified in FCC Rule Part15 Subpart B:

I attest to the accuracy of data. All measurement herein was performed by me or was made under my supervision and is correct to the best of my knowledge and belief. I assume full responsibility for the completeness of these measurements and vouch for the qualifications of all persons taking them.

The results of testing in this report apply to the product/system which was tested only. Other similar equipment will not necessarily produce the same results due to production tolerance and measurement uncertainties.

Prepared by: 

Jeong Hwan, Pyo (Test Engineer)

April 12, 2016

Reviewed by: 

Hyung Min, Choi (Chief Engineer)

April 12, 2016

### ETL Inc.

Head office: #371-51, Gasan-dong, Geumcheon-gu, Seoul, 153-803, Korea

Open site: #499-1, Sagot-ri, Seosin-myeon, Hwaseong-si, Gyeonggi-do, 445-882, Korea

Tel: 82-2-858-0786 Fax: 82-2-858-0788

*The test report merely corresponds to the test sample(s).*

*This report shall not be reproduced, in whole or in part without the written approval of ETL Inc.*

## Table of Contents

### **FCC Measurement Report**

- 1. Introduction**
- 2. Product Information**
- 3. Description of Tests**
- 4. Test Condition**
- 5. Test Results**
  - 5.1 Summary of Test Results**
  - 5.2 Radiated Emissions Measurement**
- 6. Sample Calculation**
- 7. List of test Equipment used for Measurement**

- Appendix A. FCC ID Label and Location**
- Appendix B. Test Setup Photographs**
- Appendix C. External Photographs**
- Appendix D. Internal Photographs**
- Appendix E. Block Diagram**
- Appendix F. Operating Description**
- Appendix G. User Manual**
- Appendix H. Circuit Diagram**

## FCC MEASUREMENT REPORT

**Scope** – Measurement and determination of electromagnetic emission(EME) of radio frequency devices including intentional radiators and/or unintentional radiators for compliance with the technical rules and regulations of the U.S Federal Communications Commission(FCC)

### General Information

**Applicant Name : Net Electronics LLC**

**Address : 2275 West Conuty Line Road, Suite 6-341,  
Jackson, NJ 08527, United States**

**Attention : Thomas Milone / Owner**

- **EUT Type :** RADAR DETECTOR
- **Model Number :** NR-ALP
- **FCC ID :** 2AHMC-NR
- **S/N :** Proto-type
- **Rule Part(s) :** FCC Part 15 Subpart B
- **Test Procedure :** ANSI C63.4-2001 and FCC 02-211
- **FCC Classification :** Unintentional Radiators  
CRD - Part 15 Radar Detector
- **Dates of Tests :** March 28, 2016
- **Environmental of Tests:** Temperature: (15.3 ± 1.2) °C  
Humidity: (40 ± 2) % R.H.  
Atmospheric Pressure: (102.0 ± 0.0) kPa
- **Place of Tests :** ETL Inc. Testing Lab. (FCC Designation Number : KR0022)  
  
Radiated Emission test 1;  
#499-1, Sagot-ri, Seosin-myeon, Hwaseong-si,  
Gyeonggi-do, 445-882, Korea  
  
Radiated Emission test 2 and Conducted Emission test;  
#371-51, Gasan-dong, Geumcheon-gu, Seoul, 153-803, Korea
- **Test Report No. :** ETLE160322.0265

## **1. INTRODUCTION**

The measurement tests for radiated and conducted emission test were conducted at the ETL Inc. The site is constructed in conformance with the requirements of the ANSI C63.4-2001 and CISPR Publication 16. The ETL has site descriptions on file with the FCC for 3 m and 10 m site configurations. Detailed description of test facility was found to be in compliance with FCC Rules according to the ANSI C63.4-2001 and registered to the Federal Communications Commission (FCC Designation Number : KR0022).

The measurement procedure described in American National Standard for Method of Measurement of Radio-Noise Emission from Low-Voltage Electrical and Electronic Equipment in the Range of 9 kHz to 40 GHz (ANSI C63.4-2001) was used in determining radiated and conducted emissions from the Net Electronics LLC, Model: NR-ALP.

## 2. PRODUCT INFORMATION

### 2.1 Equipment Description

The Equipment Under Test (EUT) is the RADAR DETECTOR (model: NR-ALP).

The model NR-ALP is basic model that was tested.

### 2.2 General Specification

|                             |  |
|-----------------------------|--|
| Radar                       |  |
| Receiver Type               | Double Conversion Super-heterodyne         |
| Antenna Type                | Linear polarized, self-contained           |
| Detector Type               | Scanning frequency discriminator           |
| Frequency                   |  |
| X Band                      | (10.525 ± 0.050) GHz                       |
| K Band                      | (24.150 ± 0.100) GHz                       |
| Ka Band (Super-wide)        | (34.700 ± 1.300) GHz                       |
| General                     |  |
| Dimensions                  | 38.6 mm (H) x 80.0 mm (W) x 110.0 mm (L)   |
| Operating Temperature Range | (32.5 ± 52.5) °C                           |
| Storage Temperature Range   | (32.5 ± 62.5) °C                           |
| Operating Power Source      | (13.5 ± 2.5) V DC, 200 mA, negative ground |
| High Internal Frequency     | MCU Clock → 22 MHz                         |

## 3. DESCRIPTION OF TESTS

The tests documented in this report were performed in accordance with ANSI C63.4-2001, FCC 02-211 and FCC CFR 47 15.109.

### 3.1 Radiated Emission Measurement

Radiated emission measurements were made in accordance with section 12, "Measurement of unintentional radiators other than ITE" of ANSI C63.4-2001 and FCC 02-211. The measurements were performed over the frequency range of 11.7 GHz to 12.2 GHz using antenna as the input transducer to a spectrum analyzer. The measurements were made with the detector set for "Peak" within a bandwidth of 1 MHz.

Preliminary measurements were made at 3 m using broadband antennas, and spectrum analyzer to determine the frequency producing the maximum emission in shielded room. Appropriate precaution was taken to ensure that all emission from the EUT were maximized and investigated. The system configuration, mode of operation, turntable azimuth and height with respect to the antenna were noted for each frequency found. The spectrum was scanned from Above 1 GHz; linearly polarized double ridge horn antennas were used. Final measurements were made open site at 3 m. A search was made of spectrum from 11.7 GHz to 12.2 GHz the measurements indicate that the unit meets the FCC requirements. Measurements in the 11.7 GHz to 12.2 GHz band were made with a Standard Gain Horn. The measurements in the 11.7 GHz to 12.2 GHz band represent the ambient noise levels. The attached plots were made with peak detector with the analyzer in a maximum hold for 2 minutes. The test equipment was laced on a wooden turn-table. Sufficient time for the EUT, support equipment, and test equipment was allowed in order for them to warm up to their normal operating condition. Each frequency found during pre-scan measurements was re-examined by manual. The detector function was set to CISPR Quasi-peak mode and the bandwidth of the receiver was set to 120 kHz or 1 MHz depending on the frequency of type of signal. The EUT, support equipment and interconnecting cables were re-configured to the set-up producing the maximum emission for the frequency and were placed on top of a 0.8 m high nonmetallic 1.0 m x 1.5 m table. The EUT, support equipment, and interconnecting cables were re-arranged and manipulated to maximize each emission. The turntable containing the system was rotated; the antenna height was varied 1 m to 4 m and stopped at the azimuth or height producing the maximum emission. Each emission was maximized by: varying the mode of operation to the EUT and/or support equipment and changing the polarity of the antenna, whichever determined the worst-case emission.

Photographs of the worst-case emission can be seen in Photographs of the worst-case emission test setup can be seen in Appendix B.

## 4. TEST CONDITION

### 4.1 Test Configuration

The device was configured for testing in a typical fashion (as a customer would normally use it). During the tests, the EUT and the supported equipments were installed to meet FCC requirement and operated in a manner and which tends to maximize its emission level in a typical application.

### 4.2 EUT operation

- The EUT was connected as user's guide. And during the test executed EUT is operating on the following:

| Operating Mode                                  |
|---|
| Stand-by mode                                   |
| X Band: (10.525 ± 0.050) GHz                    |
| K Band: (24.150 ± 0.100) GHz                    |
| Ka Band (Super-wide band): (34.700 ± 1.300) GHz |

### 4.3 Support Equipment Used

| Description    | Model Name | Serial No. | Manufacturer | FCC |
|----------------|------------|------------|--------------|-----|
| RADAR DETECTOR | HDR-ST1005 | NONE       | NONE         | -   |

### 4.4 Type of Cables Used

| Device from    | Device to          | Type of I/O port | Length[m] | Type of shield | Used ferrite core |
|----------------|--------------------|------------------|-----------|----------------|-------------------|
| EUT            | RADAR DETECTOR     | DATA             | 1.0       | Unshielded     | X                 |
| RADAR DETECTOR | Automotive Battery | DC Input         | 1.0       | Shielded       | X                 |

## 4.5 The setup drawing(s)

---

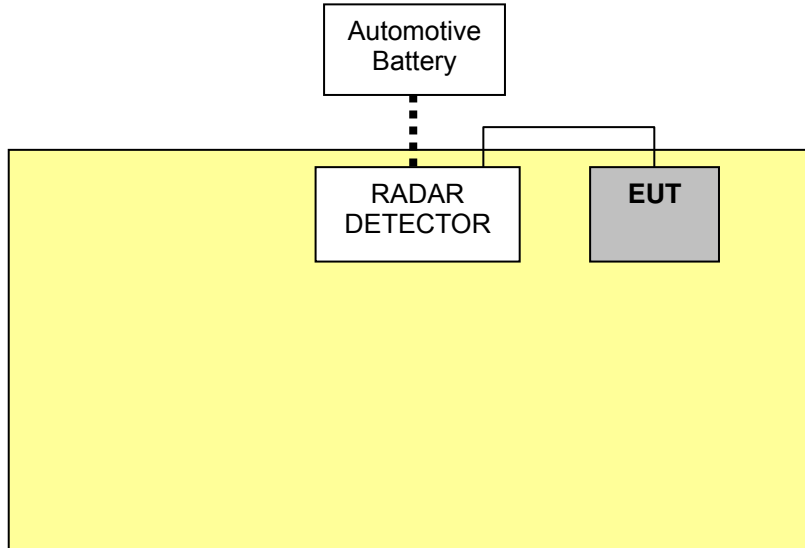

- : Data Line
- : AC Power Line
- ..... : DC Power Line
- : Adapter



## 5. TEST RESULTS

### 5.1 Summary of Test Results

The measurement results were obtained with the EUT tested in the conditions described in this report. Detailed measurement data and plots showing the maximum emission of the EUT are reported.

| FCC Rule  | Measurement Required          | Result                   |
|-----------|-------------------------------|--------------------------|
| 15.109(h) | Radiated Emission Measurement | <b>Passed by 6.10 dB</b> |

The data collected shows that the **Net Electronics LLC / RADAR DETECTOR / NR-ALP** complied with technical requirements of above rules part 15.109(h).

The equipment is not modified anything, mechanical or circuits to improve EMI status during a measurement. No EMI suppression device(s) was added and/or modified during testing.

## 5.2 Radiated Emissions Measurement

### 5.2.1 Radiated Emissions Data

|                       |   |
|-----------------------|---|
| EUT                   | RADAR DETECTOR / NR-ALP (S/N: Proto-type)           |
| Limit apply to        | FCC Part 15.109(h) and FCC 02-211                   |
| Test Date             | March 28, 2016                                      |
| Environmental of test | (15.3 ± 1.2) °C, (40 ± 2) % R.H., (102.0 ± 0.0) kPa |
| Operating Condition   | Operating on the following Bands (X, K, Ka bands)   |
| Result                | Passed by 6.10 dB                                   |

### Radiated Emission Test Data

The following table shows the highest levels of radiated emissions on both polarizations of horizontal and vertical.  
Detector mode: Peak mode (Bandwidth: 1 MHz)

| Frequency [MHz] | Reading [dB(μV)] | Polarization (*H/**V) | Factor [dB/m] | Result [dB(μV/m)] | Limit [dB(μV/m)] | Margin [dB] |
|-----------------|------------------|-----------------------|---------------|-------------------|------------------|-------------|
| 11 762.50       | 31.60            | V                     | 16.30         | 47.90             | 54.00            | 6.10        |
| 12 181.25       | 31.30            | H                     | 16.30         | 47.60             | 54.00            | 6.40        |

NOTES:

1. \* H : Horizontal polarization , \*\* V : Vertical polarization
2. Factor = Antenna factor + Cable loss - Amp. Gain
3. Result = Reading + Factor
4. Margin value = Limit - Result
5. The measurement was performed for the frequency range 11.7 GHz ~ 12.2 GHz according to the FCC Part 15.109(h) and FCC 02-211.

— : Limit

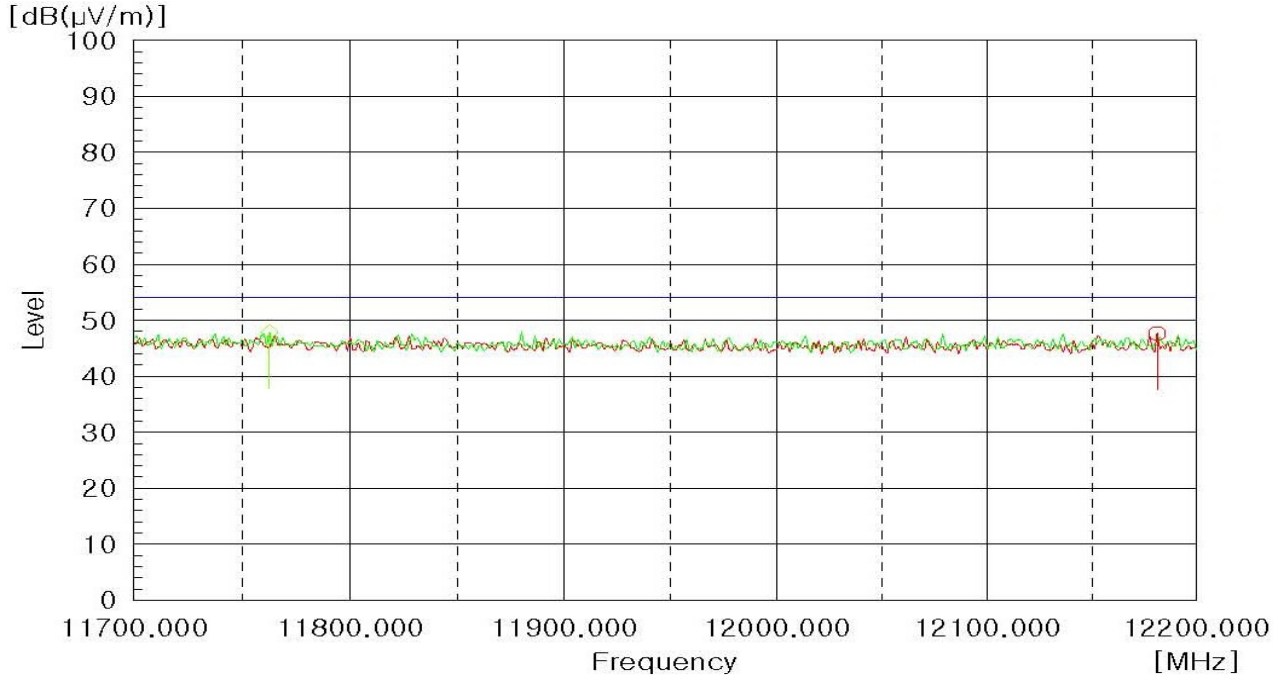

Horizontal  Vertical 

## 6. SAMPLE CALCULATION

### Sample Field Strength Calculation

The field strength is calculated by adding the Antenna Factor and Cable Factor and Minus AMP.  
The basic equation with a sample calculation is as follows:

$$FS = RA + AF + CF - PA$$

Where FS = Field Strength

RA = Receiver Amplitude

AF = Antenna Factor

CF = Cable Attenuation Factor

PA\* = Pre-amplifier Factor

\* PA is only be used for the measuring frequency above 1 GHz.

$$dB(\mu V) = 20 \log_{10} (\mu V) : \text{Equation}$$

$$dB(\mu V) = dBm + 107$$

Example : @ 11 762.50 MHz

|   |                                  |
|---|----------------------------------|
| Limit                                   | = 54.00 dB(μV/m)                 |
| Reading                                 | = 31.60 dB(μV)                   |
| Antenna Factor + Cable Loss – Amp. Gain | = 16.30 dB(μV/m)                 |
| Total                                   | = 31.60 + 16.30 = 47.90 dB(μV/m) |
| Margin                                  | = 54.00 – 47.90 = 6.10 dB        |
|   | = 6.10 dB below Limit            |

## 7. List of test equipments used for measurements

|                                     | Test Equipment               | Model      | Mfg.        | Serial No. | Cal. Date | Cal. Due Date |
|-------------------------------------|------------------------------|------------|-------------|------------|-----------|---------------|
| <input checked="" type="checkbox"/> | Horn Antenna                 | BBHA 9120D | Schwarzbeck | 277        | 14.09.18  | 16.09.18      |
| <input checked="" type="checkbox"/> | PSA Series Spectrum Analyzer | E4440A     | Agilent     | US40420382 | 15.09.18  | 16.09.18      |
| <input checked="" type="checkbox"/> | Amplifier                    | TK-PA18    | TESTEK.     | 120020     | 15.09.03  | 16.09.03      |
| <input checked="" type="checkbox"/> | Turn-Table                   | TT 1.35 SI | SES         | -          | N/A       | N/A           |
| <input checked="" type="checkbox"/> | Antenna Master               | AM 4.5     | SES         | -          | N/A       | N/A           |