

Test report

298210-1TRFWL

Date of issue: May 20, 2016

Applicant:

Tornatech Inc.

Product:

Vizitouch 2.0

Model:

Vizitouch 2.0

FCC ID:

2AHM9-ViZiTOUCH2

IC Registration number:

21471-ViZiTOUCH2

Specifications:

◆ **FCC 47 CFR Part 15 Subpart C, §15.247**

Operation in the 902–928 MHz, 2400–2483.5 MHz, 5725–5850 MHz

◆ **RSS-247, Issue 1, May 2015, Section 5**

Digital Transmission Systems (DTSS), Frequency Hopping Systems (FHSs)
and Licence-Exempt Local Area Network (LE-LAN) Devices

Test location

Company name	Nemko Canada Inc.
Address	292 Labrosse Avenue
City	Pointe-Claire
Province	QC
Postal code	H9R 5L8
Country	Canada
Telephone	+1 514 694 2684
Facsimile	+1 514 694 3528
Toll free	+1 800 563 6336
Website	www.nemko.com
Site number	FCC: 722545; IC: 2040G-5 (3 m semi anechoic chamber)

Tested by	Avul Nzenza, EMC / Wireless Specialist and Yong Huang, EMC / Wireless Specialist
Reviewed by	Andrey Adelberg, Senior Wireless/EMC Specialist
Review date	May 20, 2016
Reviewer signature	

Limits of responsibility

Note that the results contained in this report relate only to the items tested and were obtained in the period between the date of initial receipt of samples and the date of issue of the report.

This test report has been completed in accordance with the requirements of ISO/IEC 17025. All results contain in this report are within Nemko Canada's ISO/IEC 17025 accreditation.

Copyright notification

Nemko Canada Inc. authorizes the applicant to reproduce this report provided it is reproduced in its entirety and for use by the company's employees only. Any use which a third party makes of this report, or any reliance on or decisions to be made based on it, are the responsibility of such third parties.

Nemko Canada Inc. accepts no responsibility for damages, if any, suffered by any third party as a result of decisions made or actions based on this report.

© Nemko Canada Inc.

Table of contents

Table of contents	3
Section 1. Report summary	4
1.1 Applicant and manufacturer	4
1.2 Test specifications	4
1.3 Test methods.....	4
1.4 Statement of compliance	4
1.5 Exclusions.....	4
1.6 Test report revision history	4
Section 2. Summary of test results	5
2.1 FCC Part 15 Subpart C, general requirements test results.....	5
2.2 FCC Part 15 Subpart C, intentional radiators test results	5
2.3 IC RSS-GEN, Issue 4, test results	5
2.4 IC RSS-247, Issue 1, test results	6
Section 3. Equipment under test (EUT) details	7
3.1 Sample information.....	7
3.2 EUT information	7
3.3 Technical information	7
3.4 Product description and theory of operation	8
3.5 EUT exercise details.....	8
3.6 EUT setup diagram	9
Section 4. Engineering considerations	10
4.1 Modifications incorporated in the EUT	10
4.2 Technical judgment.....	10
4.3 Deviations from laboratory tests procedures.....	10
Section 5. Test conditions	11
5.1 Atmospheric conditions	11
5.2 Power supply range.....	11
Section 6. Measurement uncertainty	12
6.1 Uncertainty of measurement	12
Section 7. Test equipment	13
7.1 Test equipment list.....	13
Section 8. Testing data	14
8.1 FCC 15.207(a) and RSS-Gen 8.8 AC power line conducted emissions limits	14
8.2 FCC 15.247(a)(2) and RSS-247 5.2(1) Minimum 6 dB bandwidth for systems using digital modulation techniques.....	18
8.3 FCC 15.247(b) and RSS-247 5.4 (4) Transmitter output power and e.i.r.p. requirements	21
8.4 FCC 15.247(d) and RSS-247 5.5 Spurious (out-of-band) emissions.....	24
8.5 FCC 15.247(e) and RSS-247 5.2(2) Power spectral density for digitally modulated devices	30
Section 9. EUT photos	32
9.1 External photos	32
Section 10. Block diagrams of test set-ups	33
10.1 Radiated emissions set-up for frequencies below 1 GHz.....	33
10.2 Radiated emissions set-up for frequencies above 1 GHz.....	34
10.3 Conducted emissions set-up	34

Section 1. Report summary

1.1 Applicant and manufacturer

Company name	Tornatech Inc.
Address	7075 Place Robert-Joncas, #132
City	Montréal
Province/State	Québec
Postal/Zip code	H4M 2Z2
Country	Canada

1.2 Test specifications

FCC 47 CFR Part 15, Subpart C, Clause 15.247	Operation in the 902–928 MHz, 2400–2483.5 MHz
RSS-247, Issue 1, May 2015, Section 5	Digital Transmission Systems (DTSs), Frequency Hopping Systems (FHSs) and Licence-Exempt Local Area Network (LE-LAN) Devices

1.3 Test methods

558074 D01 DTS Meas Guidance v03r04 (Jan 7, 2016)	Guidance for Performing Compliance Measurements on Digital Transmission Systems (DTS) Operating Under §15.247
ANSI C63.10 v2013	American National Standard of Procedures for Compliance Testing of Unlicensed Wireless Devices

1.4 Statement of compliance

In the configuration tested, the EUT was found compliant.

Testing was completed against all relevant requirements of the test standard. Results obtained indicate that the product under test complies in full with the requirements tested. The test results relate only to the items tested.

See “Summary of test results” for full details.

1.5 Exclusions

None

1.6 Test report revision history

Revision #	Details of changes made to test report
TRF	Original report issued

Section 2. Summary of test results

2.1 FCC Part 15 Subpart C, general requirements test results

Part	Test description	Verdict
§15.207(a)	Conducted limits	Pass
§15.31(e)	Variation of power source	Pass ¹
§15.203	Antenna requirement	Pass ²

Notes: ¹ The testing was performed with fully charged battery

² The equipment will be professionally installed

2.2 FCC Part 15 Subpart C, intentional radiators test results

Part	Test description	Verdict
§15.247(a)(1)(i)	Frequency hopping systems operating in the 902–928 MHz band	Not applicable
§15.247(a)(1)(ii)	Frequency hopping systems operating in the 5725–5850 MHz band	Not applicable
§15.247(a)(1)(iii)	Frequency hopping systems operating in the 2400–2483.5 MHz band	Not applicable
§15.247(a)(2)	Minimum 6 dB bandwidth for systems using digital modulation techniques	Pass
§15.247(b)(1)	Maximum peak output power of frequency hopping systems operating in the 2400–2483.5 MHz band and 5725–5850 MHz band	Not applicable
§15.247(b)(2)	Maximum peak output power of Frequency hopping systems operating in the 902–928 MHz band	Not applicable
§15.247(b)(3)	Maximum peak output power of systems using digital modulation in the 902–928 MHz, 2400–2483.5 MHz, and 5725–5850 MHz bands	Pass
§15.247(c)(1)	Fixed point-to-point operation with directional antenna gains greater than 6 dBi	Not applicable
§15.247(c)(2)	Transmitters operating in the 2400–2483.5 MHz band that emit multiple directional beams	Not applicable
§15.247(d)	Spurious emissions	Pass
§15.247(e)	Power spectral density for digitally modulated devices	Pass
§15.247(f)	Time of occupancy for hybrid systems	Not applicable

2.3 IC RSS-GEN, Issue 4, test results

Part	Test description	Verdict
7.1.2	Receiver radiated emission limits	Not applicable
7.1.3	Receiver conducted emission limits	Not applicable
8.8	Power Line Conducted Emissions Limits for Licence-Exempt Radio Apparatus	Pass

Notes: ¹ According to sections 5.2 and 5.3 of RSS-Gen, Issue 4 the EUT does not have a stand-alone receiver neither scanner receiver, therefore exempt from receiver requirements.

2.4 IC RSS-247, Issue 1, test results

Part	Test description	Verdict
5.1	Frequency Hopping Systems (FHSs)	
5.1 (1)	Bandwidth of a frequency hopping channel	Not applicable
5.1 (2)	Minimum channel spacing for frequency hopping systems	Not applicable
5.1 (3)	Frequency hopping systems operating in the 902–928 MHz band	Not applicable
5.1 (4)	Frequency hopping systems operating in the 2400–2483.5 MHz band	Not applicable
5.1 (5)	Frequency hopping systems operating in the 5725–5850 MHz band	Not applicable
5.2	Digital Transmission Systems (DTSs)	
5.2 (1)	Minimum 6 dB bandwidth	Pass
5.2 (2)	Maximum power spectral density	Pass
5.3	Hybrid Systems	
5.3 (1)	Digital modulation turned off	Not applicable
5.3 (2)	Frequency hopping turned off	Not applicable
5.4	Transmitter output power and e.i.r.p. requirements	
5.4 (1)	Frequency hopping systems operating in the 902–928 MHz band	Not applicable
5.4 (2)	Frequency hopping systems operating in the 2400–2483.5 MHz band	Not applicable
5.4 (3)	Frequency hopping systems operating in the 5725–5850 MHz	Not applicable
5.4 (4)	Systems employing digital modulation techniques	Pass
5.4 (5)	Point-to-point systems in 2400–2483.5 MHz and 5725–5850 MHz band	Not applicable
5.4 (6)	Transmitters which operate in the 2400–2483.5 MHz band with multiple directional beams	Not applicable
5.5	Out-of-band emissions	Pass

Notes: None

Section 3. Equipment under test (EUT) details

3.1 Sample information

Receipt date	December 14, 2015
Nemko sample ID number	133-002105

3.2 EUT information

Product name	ViziTouch 2.0
Model	ViziTouch 2.0
Serial number	1511V111010004

3.3 Technical information

Applicant IC company number	21471
IC UPN number	VIZITOUCH2
All used IC test site(s) Reg. number	2040G-5
RSS number and Issue number	RSS-247 Issue 1, May 2015
Frequency band	2400–2483.5 MHz
Frequency Min (MHz)	2412
Frequency Max (MHz)	2462
RF power Min (W)	N/A
RF power Max (W), Conducted	0.078 (18.9 dBm)
Field strength, Units @ distance	N/A
Measured BW (MHz) (99%)	16.4
Calculated BW (kHz), as per TRC-43	N/A
Type of modulation	OFDM
Emission classification (F1D, G1D, D1D)	W7D
Transmitter spurious, Units @ distance	50.3 dB μ V/m (average) at 2483.5 MHz @ 3 m
Power requirements	110/220 Vac 50/60 Hz Note: Primary power can be voltages going from 110 V to 690 V, through a step down transformer which secondary voltage is 24 Vac, the unit works together with a power regulator which output is a steady 24 Vdc. The unit was tested with 110/120 Vac source.
Antenna information	The EUT is professionally installed. Antenna Gain 3.8 dBi (1 dB cable loss excluded), Manufacturer: Sagrad

3.4 Product description and theory of operation

The ViZiTouch 2.0 is a HMI control provided with a 1426x821 pixel, 7.0 inch color touchscreen and a membrane keypad. The main purpose of this unit is to manage and process status, alarm and control signals of TORNATECH controllers. It communicates via CAN bus with other devices and also has Wi-Fi capabilities. The ViZiTouch 2.0 is a dedicated unit. The unit runs under LINUX open source operating system and the programming environment is based on CODESYS software.

3.5 EUT exercise details

In order to verify good functioning during tests, as necessary, the unit was exercised by reaching the different menus on the touch screen, checking Wi-Fi signal and controlling the response of the keypad membrane buttons.

3.6 EUT setup diagram

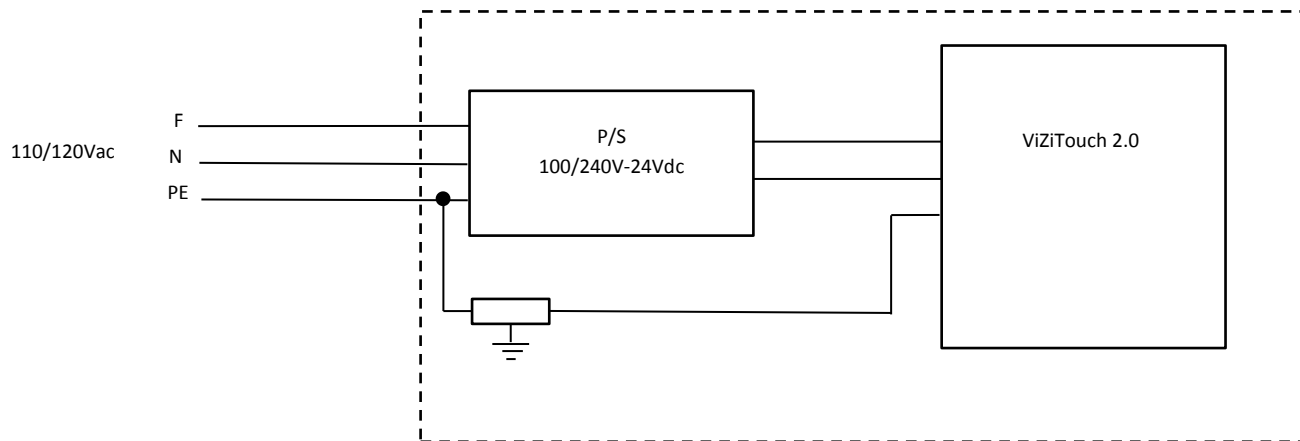

Figure 3.6-1: Setup diagram

Section 4. Engineering considerations

4.1 Modifications incorporated in the EUT

There were no modifications performed to the EUT during this assessment.

4.2 Technical judgment

None

4.3 Deviations from laboratory tests procedures

No deviations were made from laboratory procedures.

Section 5. Test conditions

5.1 Atmospheric conditions

Temperature	15–30 °C
Relative humidity	20–75 %
Air pressure	860–1060 mbar

When it is impracticable to carry out tests under these conditions, a note to this effect stating the ambient temperature and relative humidity during the tests shall be recorded and stated.

5.2 Power supply range

The normal test voltage for equipment to be connected to the mains shall be the nominal mains voltage. For the purpose of the present document, the nominal voltage shall be the declared voltage, or any of the declared voltages $\pm 5\%$, for which the equipment was designed.

Section 6. Measurement uncertainty

6.1 Uncertainty of measurement

Measurement uncertainty budgets for the tests are detailed below. Measurement uncertainty calculations assume a coverage factor of $K = 2$ with 95% certainty.

Test name	Measurement uncertainty, dB
All antenna port measurements	0.55
Conducted spurious emissions	1.13
Radiated spurious emissions	3.78
AC power line conducted emissions	3.55

Section 7. Test equipment

7.1 Test equipment list

Table 7.1-1: Equipment list

Equipment	Manufacturer	Model no.	Asset no.	Cal cycle	Next cal.
Flush mount turntable	Sunol	FM2022	FA002550	—	NCR
Controller	Sunol	SC104V	FA002551	—	NCR
Antenna mast	Sunol	TLT2	FA002552	—	NCR
Receiver/spectrum analyzer	Rohde & Schwarz	ESU 40	FA002071	1 year	April 7/16
50 Ω coax cable	C.C.A.	None	FA002603	—	VOU
50 Ω coax cable	C.C.A.	None	FA002605	—	VOU
50 Ω coax cable	C.C.A.	None	FA002607	—	VOU
Bilog antenna (20–2000 MHz)	Sunol	JB1	FA002517	1 year	Sept. 29/16
Horn antenna (1–18 GHz)	EMCO	3115	FA001452	1 year	Sept. 29/16
Horn antenna (18–40 GHz)	EMCO	3116	FA002487	2 year	July 9/16
Pre-amplifier (0.5–18 GHz)	COM-POWER	PAM-118A	FA002561	1 year	May 6/16
Pre-amplifier (18–40 GHz)	COM-POWER	PAM-840	FA002508	1 year	May 6/16
LISN	Rohde & Schwarz	ENV216	FA002514	1 year	Nov. 20/16
2400-2483 MHz Notch Filter	Microwave Circuits	N0324413	FA002693	—	VOU

Note: NCR - no calibration required, VOU - verify on use

Section 8. Testing data

8.1 FCC 15.207(a) and RSS-Gen 8.8 AC power line conducted emissions limits

8.1.1 Definitions and limits

FCC:

Except as shown in paragraphs (b) and (c) of this section, for an intentional radiator that is designed to be connected to the public utility (AC) power line, the radio frequency voltage that is conducted back onto the AC power line on any frequency or frequencies, within the band 150 kHz to 30 MHz, shall not exceed the limits in the following table, as measured using a 50 μ H/50 Ω line impedance stabilization network (LISN). Compliance with the provisions of this paragraph shall be based on the measurement of the radio frequency voltage between each power line and ground at the power terminal. The lower limit applies at the boundary between the frequency ranges.

IC:

A radio apparatus that is designed to be connected to the public utility (AC) power line shall ensure that the radio frequency voltage, which is conducted back onto the AC power line on any frequency or frequencies within the band 150 kHz to 30 MHz, shall not exceed the limits in table below.

Unless the requirements applicable to a given device state otherwise, for any radio apparatus equipped to operate from the public utility AC power supply either directly or indirectly (such as with a battery charger), the radio frequency voltage of emissions conducted back onto the AC power lines in the frequency range of 0.15 MHz to 30 MHz shall not exceed the limits shown in table below. The more stringent limit applies at the frequency range boundaries.

Table 8.1-1: Conducted emissions limit

Frequency of emission, MHz	Quasi-peak	Average**
0.15–0.5	66 to 56*	56 to 46*
0.5–5	56	46
5–30	60	50

Note: * - The level decreases linearly with the logarithm of the frequency.
 ** - A linear average detector is required.

8.1.2 Test summary

Test date	December 15, 2015	Temperature	23 °C
Test engineer	Avul Nzenza	Air pressure	1009 mbar
Verdict	Pass	Relative humidity	34 %

Section 8 Testing data
Test name FCC 15.247(a)(2) and RSS-247 5.2(1) Minimum 6 dB bandwidth for systems using digital modulation techniques
Specification FCC Part 15 Subpart C and RSS-247, Issue 1



8.1.3 Observations, settings and special notes

The EUT was set up as tabletop configuration.

The spectral scan has been corrected with transducer factors (i.e. cable loss, LISN factors, and attenuators) for determination of compliance.

A preview measurement was generated with the receiver in continuous scan mode. Emissions detected within 6 dB or above limit were re-measured with the appropriate detector against the correlating limit and recorded as the final measurement.

Receiver settings for preview measurements:

Resolution bandwidth	9 kHz
Video bandwidth	30 kHz
Detector mode	Peak and Average
Trace mode	Max Hold
Measurement time	1000 ms

Receiver settings for final measurements:

Resolution bandwidth	9 kHz
Video bandwidth	30 kHz
Detector mode	Quasi-Peak and Average
Trace mode	Max Hold
Measurement time	1000 ms

Section 8

Testing data

Test name

FCC 15.247(a)(2) and RSS-247 5.2(1) Minimum 6 dB bandwidth for systems using digital modulation techniques

Specification

FCC Part 15 Subpart C and RSS-247, Issue 1



8.1.4 Test data

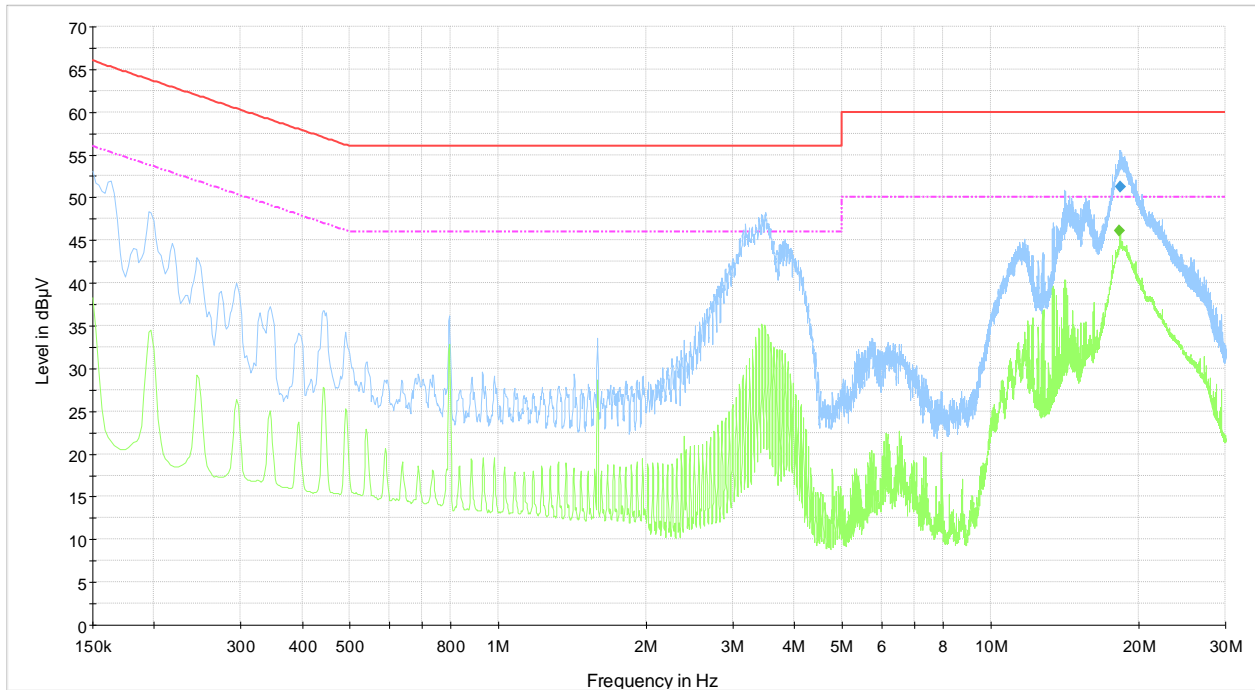

5R298210_Cond Emissions_Phase_Dec 15, 2015

- CISPR 22 Mains QP Class B
- - - CISPR 22 Mains AV Class B
- Preview Result 1-PK+
- Preview Result 2-AVG
- ◆ Final Result 1-QPK
- ◆ Final Result 2-AVG

Plot 8.1-1: Conducted emissions on phase line

Table 8.1-2: Average conducted emissions results on phase line

Frequency, MHz	Average result, dBµV	Meas. Time, ms	Bandwidth, kHz	Filter	Conductor	Correction, dB	Margin, dB	Limit, dBµV
18.244	52.12	15000	9	On	N	10.68	7.90	60.00

Sample calculation:

Correction factor (dB) = LISN factor IL (dB) + cable loss (dB) + attenuator (dB)

Result (dBµV) = XX dBµV (reading from receiver) + XX dB (Correction factor)

Example:

43.5 dBµV = 23.2 dBµV (receiver reading) + 10.1 dB (LISN factor IL) + 0.2 dB (cable loss) + 10 dB (attenuator)

Section 8

Testing data

Test name

FCC 15.247(a)(2) and RSS-247 5.2(1) Minimum 6 dB bandwidth for systems using digital modulation techniques

Specification

FCC Part 15 Subpart C and RSS-247, Issue 1

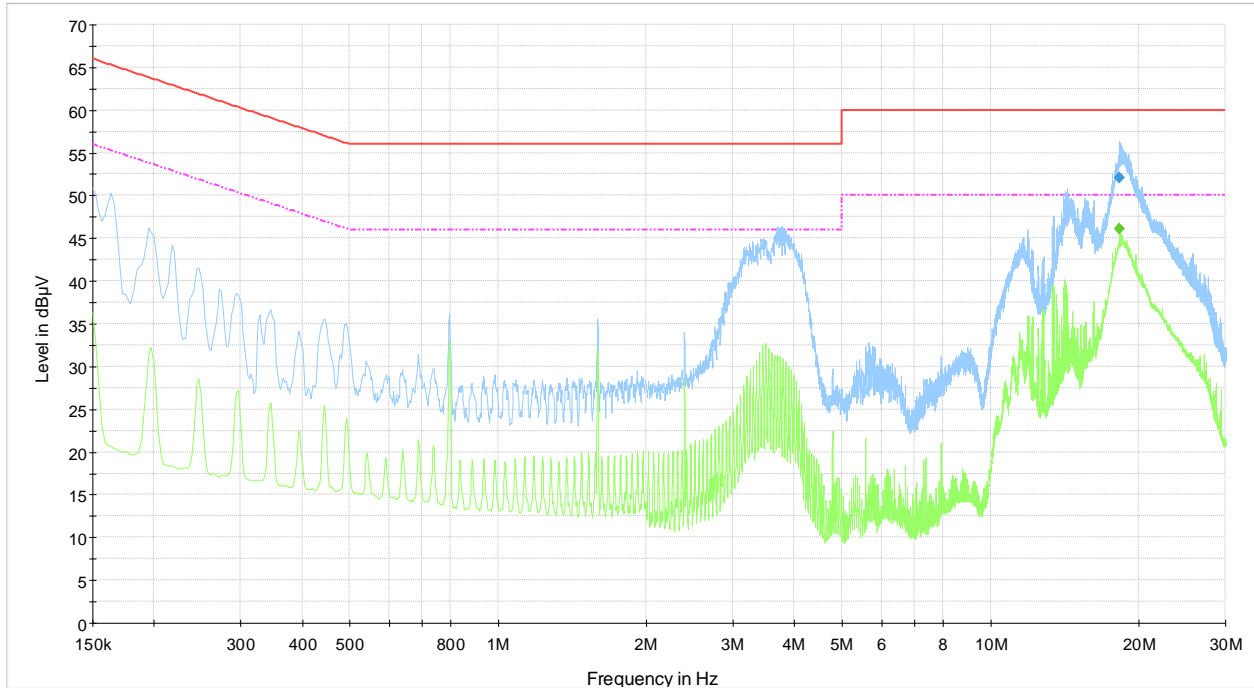

5R298210_Cond Emissions_Neutral_Dec 15, 2015

- CISPR 22 Mains QP Class B
- - - CISPR 22 Mains AV Class B
- Preview Result 1-PK+
- Preview Result 2-AVG
- ◆ Final Result 1-QPK
- ◆ Final Result 2-AVG

Plot 8.1-2: Conducted emissions on neutral line

Table 8.1-3: Average conducted emissions results on neutral line

Frequency, MHz	Average result, dBµV	Meas. Time, ms	Bandwidth, kHz	Filter	Conductor	Correction, dB	Margin, dB	Limit, dBµV
18.305	46.06	15000	9	On	N	10.68	3.90	50.00

Sample calculation:

Correction factor (dB) = LISN factor IL (dB) + cable loss (dB) + attenuator (dB)

Result (dBµV) = XX dBµV (reading from receiver) + XX dB (Correction factor)

Example:

43.5 dBµV = 23.2 dBµV (receiver reading) + 10.1 dB (LISN factor IL) + 0.2 dB (cable loss) + 10 dB (attenuator)

8.2 FCC 15.247(a)(2) and RSS-247 5.2(1) Minimum 6 dB bandwidth for systems using digital modulation techniques

8.2.1 Definitions and limits

FCC and IC:

- (a) Operation under the provisions of this Section is limited to frequency hopping and digitally modulated intentional radiators that comply with the following provisions:
- (2) Systems using digital modulation techniques may operate in the 902–928 MHz, 2400–2483.5 MHz and 5725–5850 MHz bands. The minimum 6 dB bandwidth shall be at least 500 kHz.

8.2.2 Test summary

Test date	December 14, 2015	Temperature	23.5 °C
Test engineer	Avul Nzenza	Air pressure	1006 mbar
Verdict	Pass	Relative humidity	34 %

8.2.3 Observations, settings and special notes

Spectrum analyser settings:

Resolution bandwidth	100 kHz
Video bandwidth	≥RBW
Frequency span	2 MHz
Detector mode	Peak
Trace mode	Max Hold

8.2.4 Test data

Table 8.2-1: 6 dB bandwidth results

Frequency, MHz	6 dB bandwidth, kHz	Minimum limit, kHz	Margin, kHz
2412	16298	500	15798
2442	15721	500	15221
2462	16298	500	15798

Table 8.2-2: 99% bandwidth results

Frequency, MHz	99% bandwidth, kHz
2412	16298
2442	16394
2462	16298

Section 8

Test name

Specification

Testing data

FCC 15.247(a)(2) and RSS-247 5.2(1) Minimum 6 dB bandwidth for systems using digital modulation techniques

FCC Part 15 Subpart C and RSS-247, Issue 1

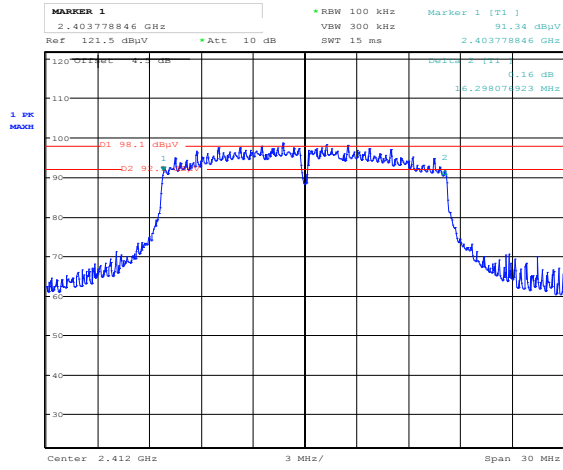

Date: 14.DEC.2015 09:42:53

Figure 8.2-1: 6 dB bandwidth on Low Channel

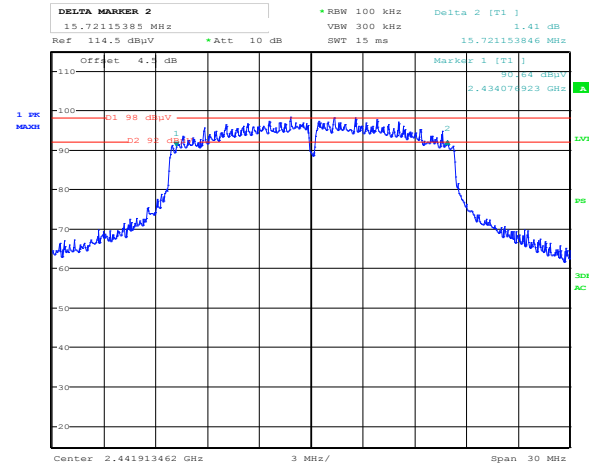

Date: 15.DEC.2015 14:40:35

Figure 8.2-2: 6 dB bandwidth on Mid Channel

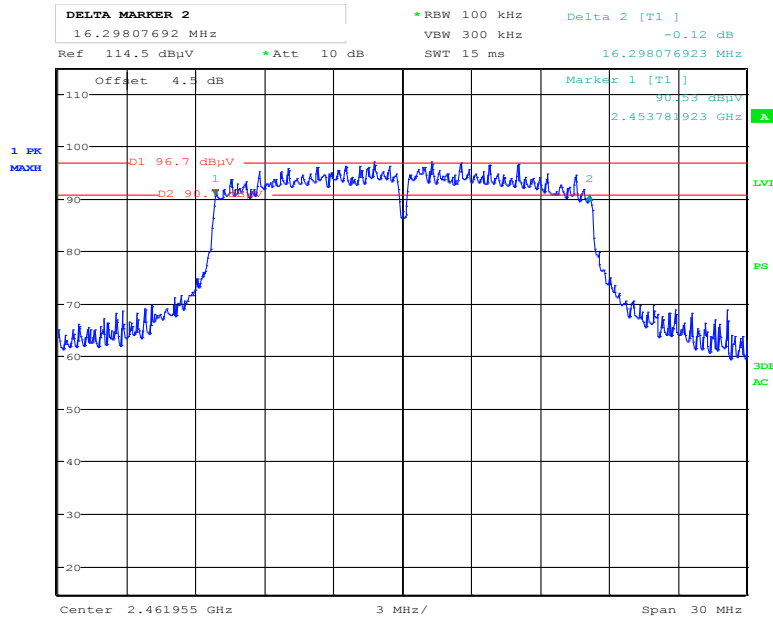

Date: 15.DEC.2015 14:36:54

Figure 8.2-3: 6 dB bandwidth on High Channel

Section 8

Test name

Specification

Testing data

FCC 15.247(a)(2) and RSS-247 5.2(1) Minimum 6 dB bandwidth for systems using digital modulation techniques

FCC Part 15 Subpart C and RSS-247, Issue 1

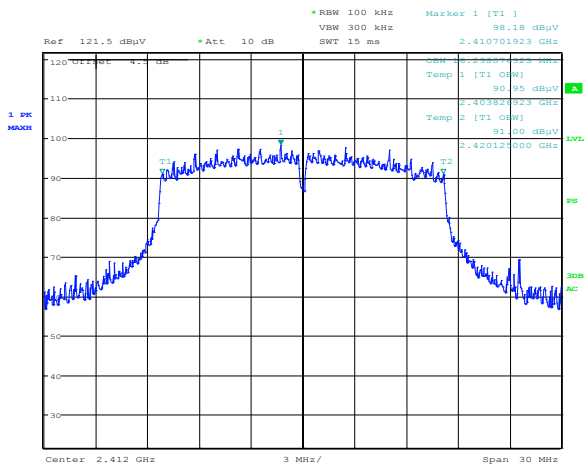

Date: 14.DEC.2015 09:28:15

Figure 8.2-4: 99% bandwidth on Low Channel

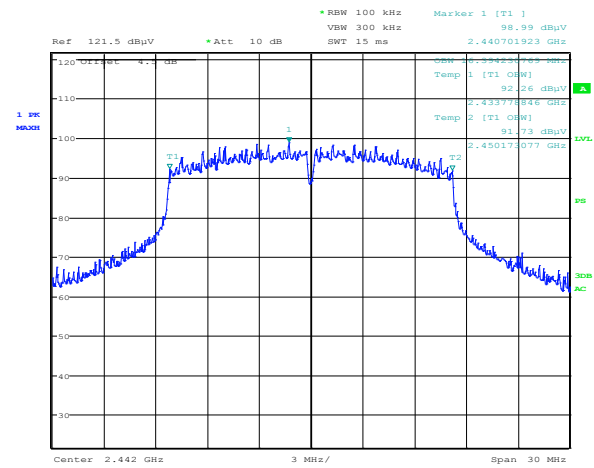

Date: 14.DEC.2015 09:55:40

Figure 8.2-5: 99% bandwidth on Mid Channel

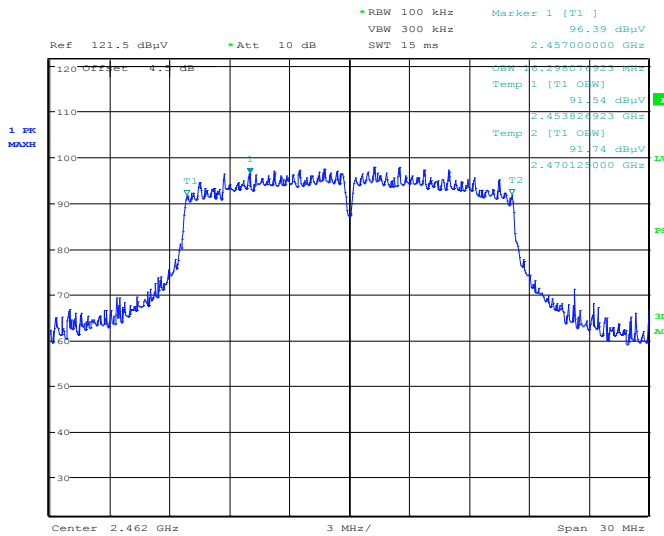

Date: 14.DEC.2015 11:04:13

Figure 8.2-6: 99% bandwidth on High Channel

8.3 FCC 15.247(b) and RSS-247 5.4 (4) Transmitter output power and e.i.r.p. requirements

8.3.1 Definitions and limits

FCC:

- (b) The maximum peak conducted output power of the intentional radiator shall not exceed the following:
- (3) For systems using digital modulation in the 902–928 MHz, 2400–2483.5 MHz, and 5725–5850 MHz bands: 1 W (30 dBm). As an alternative to a peak power measurement, compliance with the one Watt limit can be based on a measurement of the maximum conducted output power. Maximum Conducted Output Power is defined as the total transmit power delivered to all antennas and antenna elements averaged across all symbols in the signaling alphabet when the transmitter is operating at its maximum power control level. Power must be summed across all antennas and antenna elements. The average must not include any time intervals during which the transmitter is off or is transmitting at a reduced power level. If multiple modes of operation are possible (e.g., alternative modulation methods), the maximum conducted output power is the highest total transmit power occurring in any mode.
 - (4) The conducted output power limit specified in paragraph (b) of this section is based on the use of antennas with directional gains that do not exceed 6 dBi. Except as shown in paragraph (c) of this section, if transmitting antennas of directional gain greater than 6 dBi are used, the conducted output power from the intentional radiator shall be reduced below the stated values in paragraphs (b)(1), (b)(2), and (b)(3) of this section, as appropriate, by the amount in dB that the directional gain of the antenna exceeds 6 dBi.
 - (i) Systems operating in the 2400–2483.5 MHz band that are used exclusively for fixed, point-to-point operations may employ transmitting antennas with directional gain greater than 6 dBi provided the maximum peak output power of the intentional radiator is reduced by 1 dB for every 3 dB that the directional gain of the antenna exceeds 6 dBi.

Fixed, point-to-point operation, as used in paragraphs (b)(3)(i) and (b)(3)(ii) of this section, excludes the use of point-to-multipoint systems, omnidirectional applications, and multiple co-located intentional radiators transmitting the same information. The operator of the spread spectrum intentional radiator or, if the equipment is professionally installed, the installer is responsible for ensuring that the system is used exclusively for fixed, point-to-point operations. The instruction manual furnished with the intentional radiator shall contain language in the installation instructions informing the operator and the installer of this responsibility.

- (c) Operation with directional antenna gains greater than 6 dBi.
- (2) In addition to the provisions in paragraphs (b)(1), (b)(3), (b)(4) and (c)(1)(i) of this section, transmitters operating in the 2400–2483.5 MHz band that emit multiple directional beams, simultaneously or sequentially, for the purpose of directing signals to individual receivers or to groups of receivers provided the emissions comply with the following:
 - (i) Different information must be transmitted to each receiver.
 - (ii) If the transmitter employs an antenna system that emits multiple directional beams but does not do emit multiple directional beams simultaneously, the total output power conducted to the array or arrays that comprise the device, i.e., the sum of the power supplied to all antennas, antenna elements, staves, etc. and summed across all carriers or frequency channels, shall not exceed the limit specified in paragraph (b)(1) or (b)(3) of this section, as applicable. However, the total conducted output power shall be reduced by 1 dB below the specified limits for each 3 dB that the directional gain of the antenna/antenna array exceeds 6 dBi. The directional antenna gain shall be computed as follows:
 - (A) The directional gain shall be calculated as the sum of 10 log (number of array elements or staves) plus the directional gain of the element or staff having the highest gain.

IC:
For DTSs employing digital modulation techniques operating in the bands 902–928 MHz and 2400–2483.5 MHz, the maximum peak conducted output power shall not exceed 1W. Except as provided in Section 5.4(5), the e.i.r.p. shall not exceed 4 W.

Fixed point-to-point systems in the bands 2400–2483.5 MHz and 5725–5850 MHz are permitted to have an e.i.r.p. higher than 4 W provided that the higher e.i.r.p. is achieved by employing higher gain directional antennas and not higher transmitter output powers. Point-to-multipoint systems, omnidirectional applications and multiple co-located transmitters transmitting the same information are prohibited from exceeding an e.i.r.p. of 4 W.



8.3.2 Test summary

Test date	February 26, 2016	Temperature	24 °C
Test engineer	Yong Huang	Air pressure	1007 mbar
Verdict	Pass	Relative humidity	31 %

8.3.3 Observations, settings and special notes

The test was performed according to ANSI C63.10:2013, section 11.9.1.2 Integrated band power method.

8.3.4 Test data

Table 8.3-1: Output power measurements results

Frequency, MHz	Conducted output power, dBm	Output power limit, dBm	Output power margin, dB
2412	18.6	30	11.4
2442	18.9	30	11.1
2462	18.9	30	11.1

Note: As per customer, antenna gain is less than 6 dBi; therefore EIRP is less than 36 dBm.

8.3.1 Test data

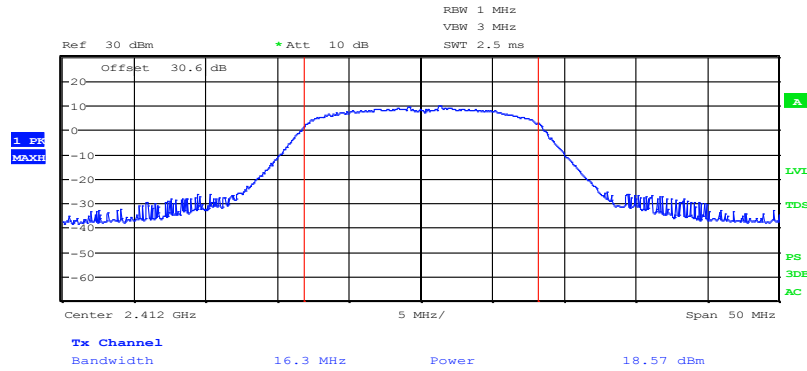

Figure 8.3-1: output power plot on Low channel

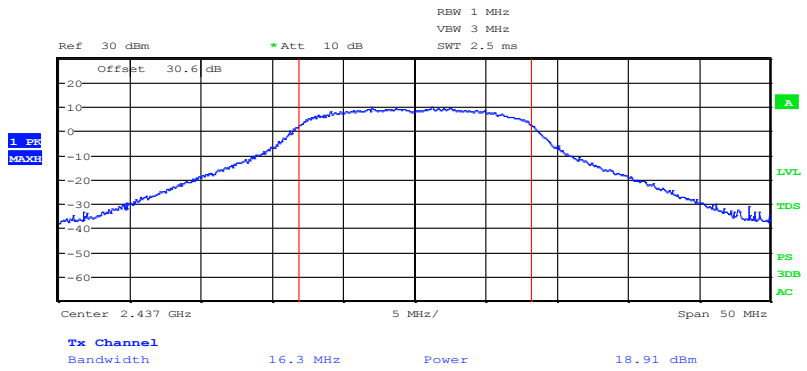

Figure 8.3-2: output power plot on Mid channel

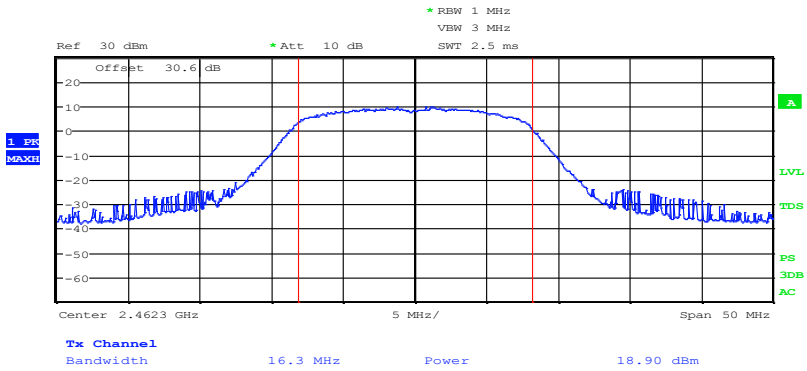

Figure 8.3-3: output power plot on High channel

8.4 FCC 15.247(d) and RSS-247 5.5 Spurious (out-of-band) emissions

8.4.1 Definitions and limits

FCC:
 In any 100 kHz bandwidth outside the frequency band in which the spread spectrum or digitally modulated intentional radiator is operating, the radio frequency power that is produced by the intentional radiator shall be at least 20 dB below that in the 100 kHz bandwidth within the band that contains the highest level of the desired power, based on either an RF conducted or a radiated measurement, provided the transmitter demonstrates compliance with the peak conducted power limits. If the transmitter complies with the conducted power limits based on the use of RMS averaging over a time interval, as permitted under paragraph (b)(3) of this section, the attenuation required under this paragraph shall be 30 dB instead of 20 dB. Attenuation below the general limits specified in §15.209(a) is not required. In addition, radiated emissions which fall in the restricted bands, as defined in §15.205(a), must also comply with the radiated emission limits specified in §15.209(a) (see §15.205(c)).

IC:
 In any 100 kHz bandwidth outside the frequency band in which the spread spectrum or digitally modulated device is operating, the RF power that is produced shall be at least 20 dB below that in the 100 kHz bandwidth within the band that contains the highest level of the desired power, based on either an RF conducted or a radiated measurement, provided that the transmitter demonstrates compliance with the peak conducted power limits. If the transmitter complies with the conducted power limits based on the use of root-mean-square averaging over a time interval, as permitted under Section 5.4(4), the attenuation required shall be 30 dB instead of 20 dB. Attenuation below the general field strength limits specified in RSS-Gen is not required.

Table 8.4-1: FCC §15.209 and RSS-Gen – Radiated emission limits

Frequency, MHz	Field strength of emissions		Measurement distance, m
	µV/m	dBµV/m	
0.009–0.490	2400/F	$67.6 - 20 \times \log_{10}(F)$	300
0.490–1.705	24000/F	$87.6 - 20 \times \log_{10}(F)$	30
1.705–30.0	30	29.5	30
30–88	100	40.0	3
88–216	150	43.5	3
216–960	200	46.0	3
above 960	500	54.0	3

Notes: In the emission table above, the tighter limit applies at the band edges.

For frequencies above 1 GHz the limit on peak RF emissions is 20 dB above the maximum permitted average emission limit applicable to the equipment under test

Table 8.4-2: IC restricted frequency bands

MHz	MHz	MHz	GHz
0.090–0.110	12.51975–12.52025	399.9–410	5.35–5.46
2.1735–2.1905	12.57675–12.57725	608–614	7.25–7.75
3.020–3.026	13.36–13.41	960–1427	8.025–8.5
4.125–4.128	16.42–16.423	1435–1626.5	9.0–9.2
4.17725–4.17775	16.69475–16.69525	1645.5–1646.5	9.3–9.5
4.20725–4.20775	16.80425–16.80475	1660–1710	10.6–12.7
5.677–5.683	25.5–25.67	1718.8–1722.2	13.25–13.4
6.215–6.218	37.5–38.25	2200–2300	14.47–14.5
6.26775–6.26825	73–74.6	2310–2390	15.35–16.2
6.31175–6.31225	74.8–75.2	2655–2900	17.7–21.4
8.291–8.294	108–138	3260–3267	22.01–23.12
8.362–8.366	156.52475–156.52525	3332–3339	23.6–24.0
8.37625–8.38675	156.7–156.9	3345.8–3358	31.2–31.8
8.41425–8.41475	240–285	3500–4400	36.43–36.5
12.29–12.293	322–335.4	4500–5150	Above 38.6

Note: Certain frequency bands listed in Table 8.4-2 and above 38.6 GHz are designated for low-power licence-exempt applications. These frequency bands and the requirements that apply to the devices are set out in this Standard

Table 8.4-3: FCC restricted frequency bands

MHz	MHz	MHz	GHz
0.090–0.110	16.42–16.423	399.9–410	4.5–5.15
0.495–0.505	16.69475–16.69525	608–614	5.35–5.46
2.1735–2.1905	16.80425–16.80475	960–1240	7.25–7.75
4.125–4.128	25.5–25.67	1300–1427	8.025–8.5
4.17725–4.17775	37.5–38.25	1435–1626.5	9.0–9.2
4.20725–4.20775	73–74.6	1645.5–1646.5	9.3–9.5
6.215–6.218	74.8–75.2	1660–1710	10.6–12.7
6.26775–6.26825	108–121.94	1718.8–1722.2	13.25–13.4
6.31175–6.31225	123–138	2200–2300	14.47–14.5
8.291–8.294	149.9–150.05	2310–2390	15.35–16.2
8.362–8.366	156.52475–156.52525	2483.5–2500	17.7–21.4
8.37625–8.38675	156.7–156.9	2690–2900	22.01–23.12
8.41425–8.41475	162.0125–167.17	3260–3267	23.6–24.0
12.29–12.293	167.72–173.2	3332–3339	31.2–31.8
12.51975–12.52025	240–285	3345.8–3358	36.43–36.5
12.57675–12.57725	322–335.4	3600–4400	Above 38.6
13.36–13.41			

8.4.2 Test summary

Test date	February 26, 2016	Temperature	24 °C
Test engineer	Yong Huang	Air pressure	1007 mbar
Verdict	Pass	Relative humidity	31 %

8.4.3 Observations, settings and special notes

The spectrum was searched from 30 MHz to the 10th harmonic.
 EUT was set to continuously transmit.
 Since fundamental power was tested using peak method, the spurious emissions limit is –20 dBc/100 kHz

Spectrum analyser settings for radiated measurements within restricted bands below 1 GHz:

Resolution bandwidth:	100 kHz
Video bandwidth:	300 kHz
Detector mode:	Peak
Trace mode:	Max Hold

Spectrum analyser settings for peak radiated measurements within restricted bands above 1 GHz:

Resolution bandwidth:	1 MHz
Video bandwidth:	3 MHz
Detector mode:	Peak
Trace mode:	Max Hold

Resolution bandwidth:	1 MHz
Video bandwidth:	3 MHz
Detector mode:	Average
Trace mode:	Max Hold

Section 8 Testing data
Test name FCC 15.247(d) and RSS-247 5.5 Spurious (out-of-band) emissions
Specification FCC Part 15 Subpart C and RSS-247, Issue 1



Spectrum analyser settings for conducted spurious emissions measurements:

Resolution bandwidth:	100 kHz
Video bandwidth:	300 kHz
Detector mode:	Peak
Trace mode:	Max Hold

8.4.4 Test data

Table 8.4-4: Radiated field strength measurement results

Channel	Frequency, MHz	Peak Field strength, dB μ V/m		Margin, dB	Average Field strength, dB μ V/m		Margin, dB
		Measured	Limit		Measured	Limit	
Low	2390	55.3	74	18.7	49.5	54	4.5
High	2483.5	60.9	74	13.1	50.3	54	3.7

Notes: None.

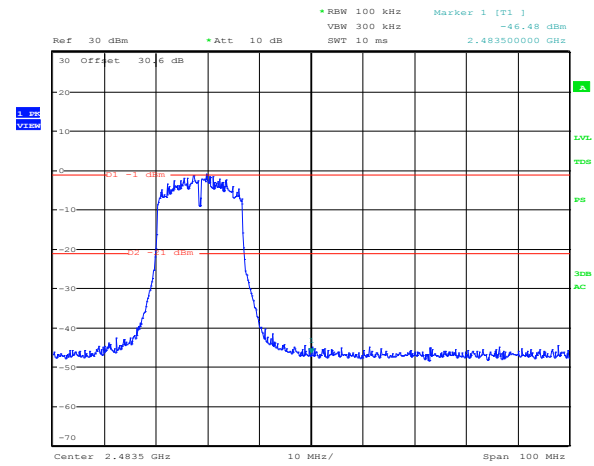
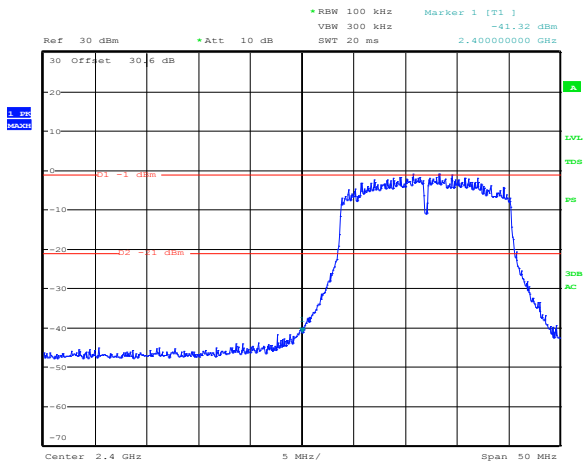

Date: 26.FEB.2016 10:22:36

Date: 26.FEB.2016 10:36:25

Figure 8.4-1: Conducted Band edge emission, low channel

Figure 8.4-2: Conducted Band edge emissions for high channel

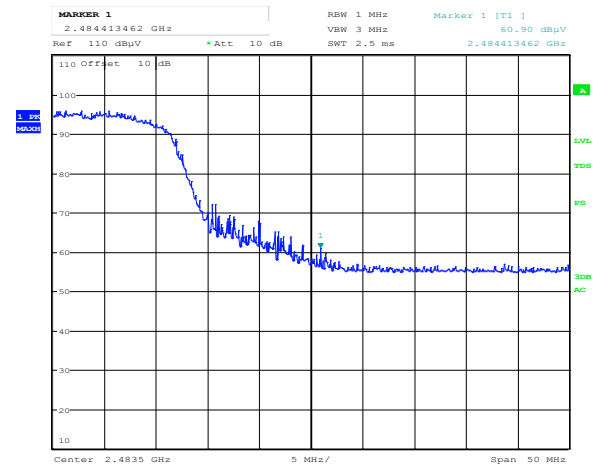
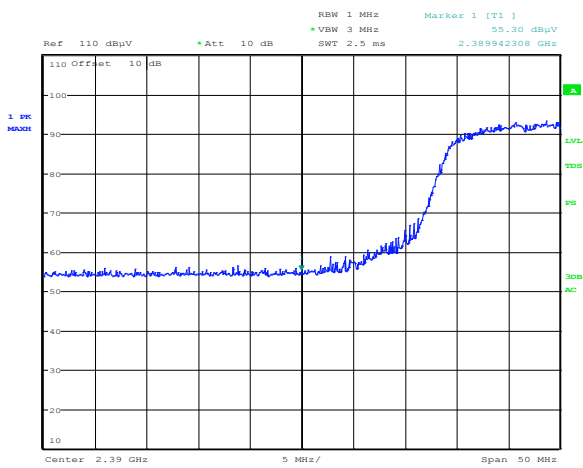

Date: 26.FEB.2016 13:32:59

Date: 26.FEB.2016 13:28:38

Figure 8.4-3: Radiated spurious emission, band edge, low channel

Figure 8.4-4: Radiated spurious emission, band edge, High channel

Section 8
Test name
Specification

Testing data
 FCC 15.247(d) and RSS-247 5.5 Spurious (out-of-band) emissions
 FCC Part 15 Subpart C and RSS-247, Issue 1

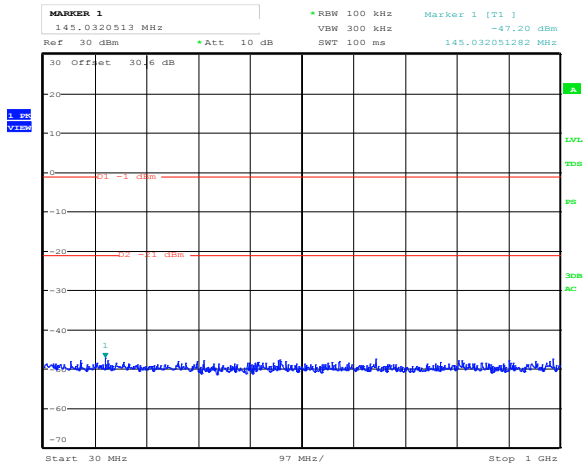

Date: 26.FEB.2016 10:40:40

Figure 8.4-5: Conducted spurious emissions, Low channel_30MHz – 1GHz

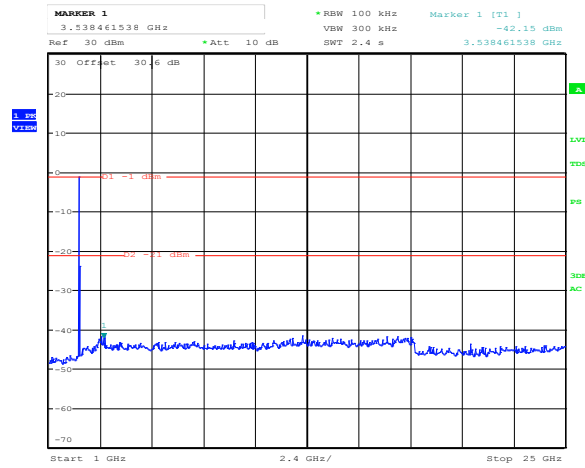

Date: 26.FEB.2016 10:42:13

Figure 8.4-6: Conducted spurious emissions, Low channel_1 GHz – 25GHz

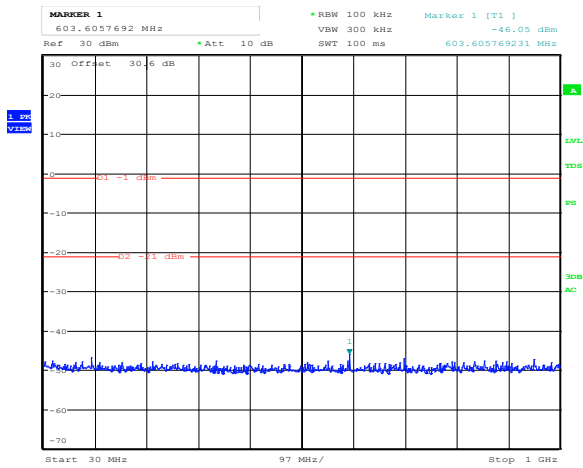

Date: 26.FEB.2016 10:38:40

Figure 8.4-7: Conducted spurious emissions, Mid channel_30MHz – 1GHz

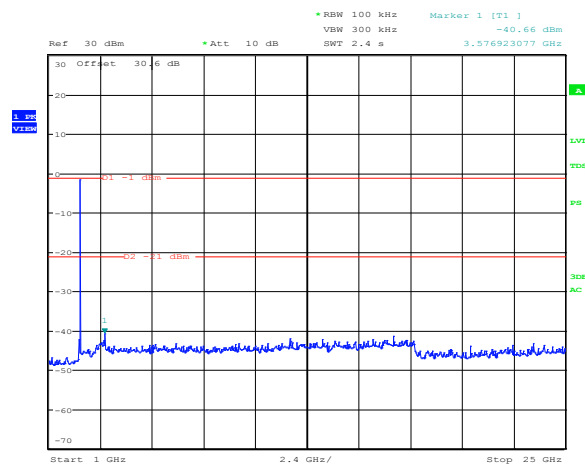

Date: 26.FEB.2016 10:39:33

Figure 8.4-8: Conducted spurious emissions, Mid channel_1GHz – 25GHz

Section 8
Test name
Specification

Testing data
FCC 15.247(d) and RSS-247 5.5 Spurious (out-of-band) emissions
FCC Part 15 Subpart C and RSS-247, Issue 1

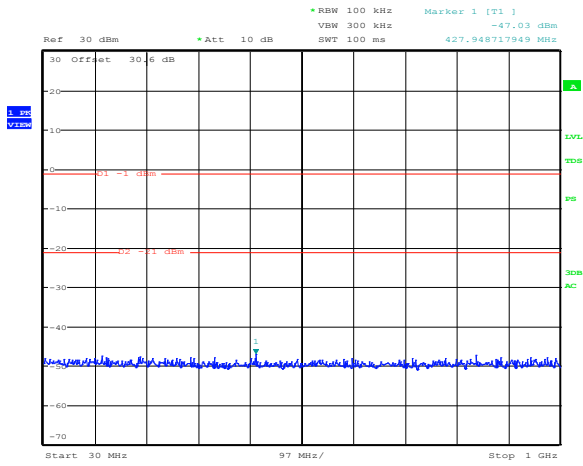

Date: 26.FEB.2016 10:37:39

Figure 8.4-9: Conducted spurious emissions, High channel_30MHz – 1GHz

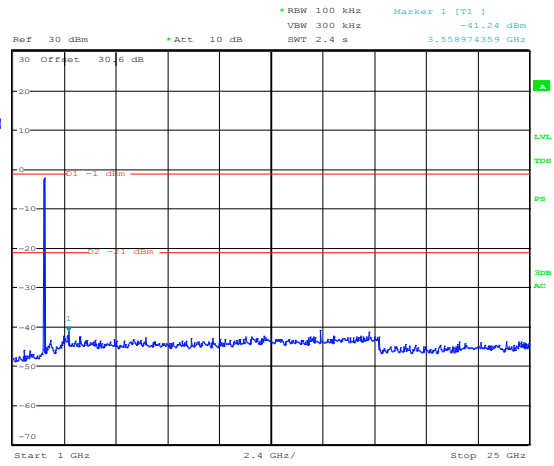

Date: 26.FEB.2016 10:34:42

Figure 8.4-10: Conducted spurious emissions, High channel_1GHz – 25 GHz

8.5 FCC 15.247(e) and RSS-247 5.2(2) Power spectral density for digitally modulated devices

8.5.1 Definitions and limits

FCC:

For digitally modulated systems, the power spectral density conducted from the intentional radiator to the antenna shall not be greater than 8 dBm in any 3 kHz band during any time interval of continuous transmission. This power spectral density shall be determined in accordance with the provisions of paragraph (b) of this section. The same method of determining the conducted output power shall be used to determine the power spectral density.

IC:

The transmitter power spectral density conducted from the transmitter to the antenna shall not be greater than 8 dBm in any 3 kHz band during any time interval of continuous transmission. This power spectral density shall be determined in accordance with the provisions of Section 5.4(4), (i.e. the power spectral density shall be determined using the same method as is used to determine the conducted output power).

8.5.2 Test summary

Test date	February 26, 2016	Temperature	24 °C
Test engineer	Yong Huang	Air pressure	1007 mbar
Verdict	Pass	Relative humidity	31 %

8.5.3 Observations, settings and special notes

The test was performed using method described in ANSI 63.10:2013, section 11.10.2 Method PKPSD (peak PSD) and Section 10.2 of 558074 D01 DTS Meas Guidance v03r04.

Resolution bandwidth:	50 kHz
Video bandwidth:	200 kHz
Frequency span:	30 MHz
Detector mode:	Peak
Trace mode:	Max hold

8.5.4 Test data

Table 8.5-1: PSD measurements results

Frequency, MHz	PSD, dBm/50 kHz	PSD limit, dBm/3 kHz	Margin, dB
2412	-3.54	8.00	11.54
2442	-3.27	8.00	11.27
2462	-3.79	8.00	11.79

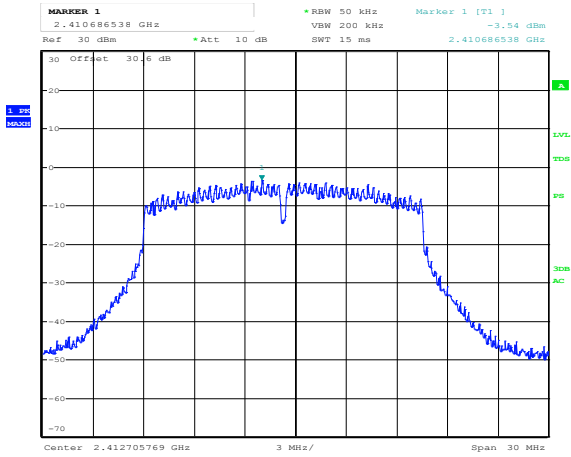

Date: 26.FEB.2016 10:18:47

Figure 8.5-1: PSD plot on Low channel

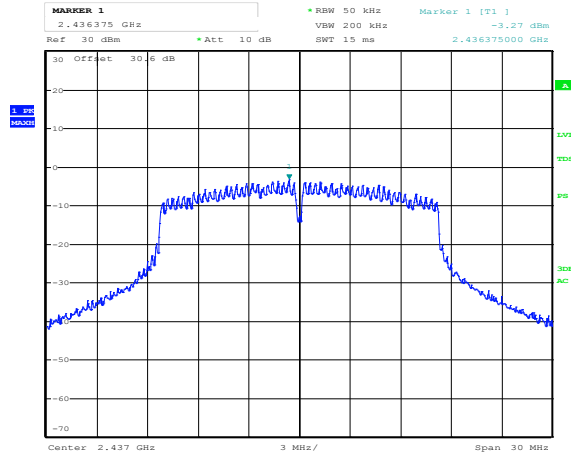

Date: 26.FEB.2016 10:07:56

Figure 8.5-2: PSD plot on Mid channel

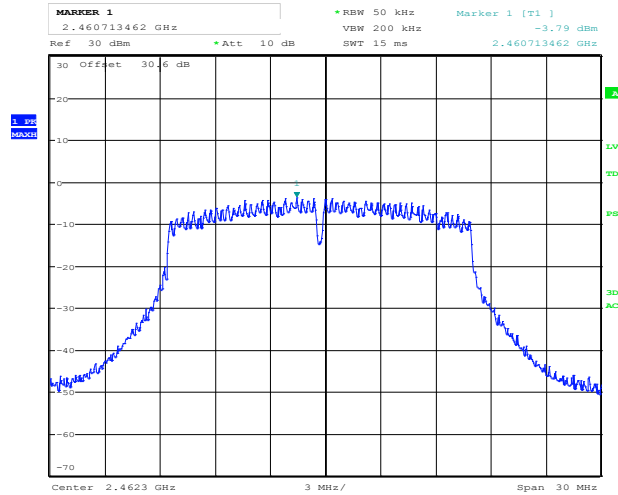

Date: 26.FEB.2016 10:10:01

Figure 8.5-3: PSD plot on High channel

Section 9. EUT photos

9.1 External photos



Figure 9.1-1: Front view photo



Figure 9.1-2: Rear view photo

Section 10. Block diagrams of test set-ups

10.1 Radiated emissions set-up for frequencies below 1 GHz

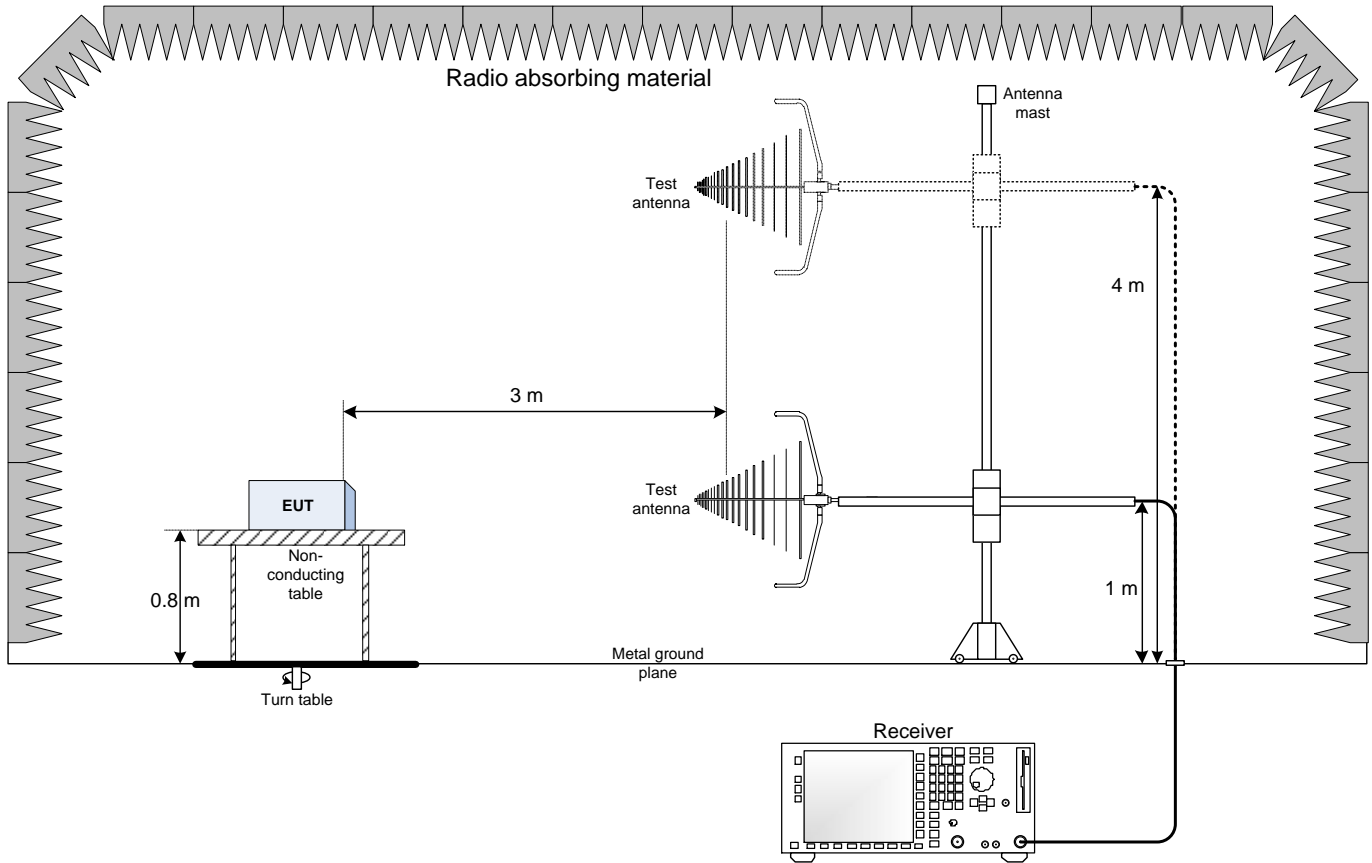

10.2 Radiated emissions set-up for frequencies above 1 GHz

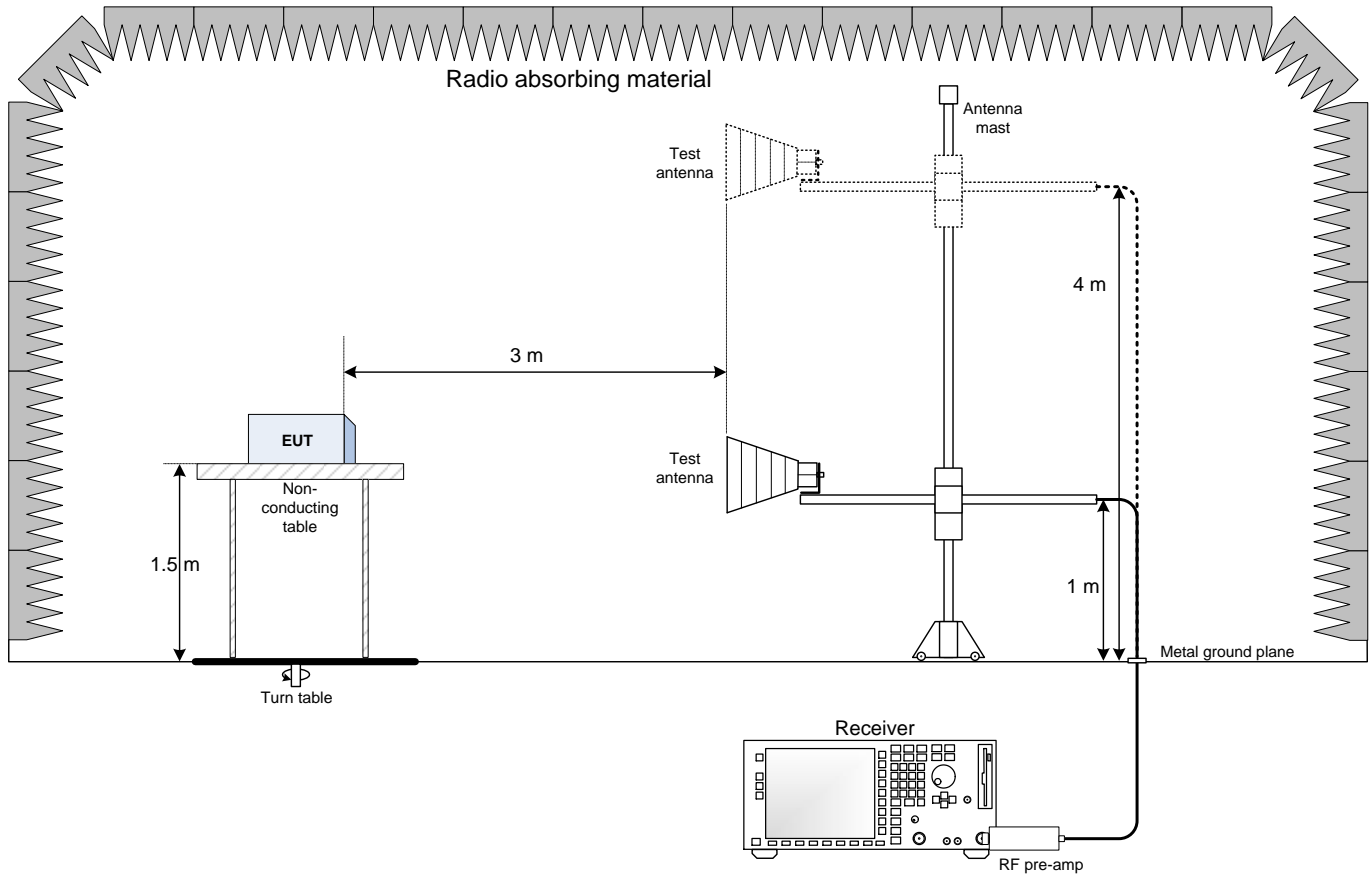

10.3 Conducted emissions set-up

