

Test Report

FCC ID: 2AHLZ-CWI510

Date of issue: Aug. 28, 2019

Report Number: MTi19070804-1E4

Sample Description: Notebook

Model(s): CWI510, CWI533, CWI534, CWI535, CWI536, CWI560, CWI561, CWI562, CWI563, CWI564

Applicant: CHUWI TECHNOLOGY (ShenZhen) CO., LIMITED

Address: 2 Floor Building 3 LiJinCheng Industrial park the east of Gongye road LongHua Shenzhen China.

Date of Test: July 18, 2019 to Aug. 28, 2019

Shenzhen Microtest Co., Ltd.
<http://www.mtitest.com>



Table of Contents

1	GENERAL INFORMATION	5
1.1	DESCRIPTION OF EUT	5
1.2	OPERATION CHANNEL LIST	6
1.3	TEST CHANNEL LIST	6
1.4	ANCILLARY EQUIPMENT LIST	7
1.5	DESCRIPTION OF SUPPORT UNITS	8
2	SUMMARY OF THE TEST RESULTS	9
3	TEST FACILITIES AND ACCREDITATIONS	10
3.1	TEST LABORATORY	10
3.2	ENVIRONMENTAL CONDITIONS	10
3.3	MEASUREMENT UNCERTAINTY	11
3.4	TEST SOFTWARE	11
4	EQUIPMENT LIST	12
5	TEST RESULTS	13
5.1	ANTENNA REQUIREMENT	13
5.1.1	<i>Standard requirement</i>	13
5.1.2	<i>EUT Antenna</i>	13
5.2	RF OUTPUT POWER	14
5.2.1	<i>Limit</i>	14
5.2.2	<i>Test procedure</i>	14
5.2.3	<i>Test setup</i>	14
5.2.4	<i>Test results</i>	15
5.3	POWER LINE CONDUCTED EMISSION	17
5.3.1	<i>Limits</i>	17
5.3.2	<i>Test setup</i>	17
5.3.3	<i>Test procedure</i>	18
5.3.4	<i>Test results</i>	19
5.4	26dB EMISSION BANDWIDTH AND OCCUPIED BANDWIDTH	23
5.4.1	<i>Limit</i>	23
5.4.2	<i>Test procedure</i>	23
5.4.3	<i>Test setup</i>	23
5.4.4	<i>Test results</i>	24
5.5	6dB BANDWIDTH	31
5.5.1	<i>Limit</i>	31
5.5.2	<i>Test procedure</i>	31
5.5.3	<i>Test setup</i>	31
5.5.4	<i>Test results</i>	31
5.6	RADIATED SPURIOUS EMISSION	36
5.6.1	<i>Test procedure</i>	37
5.6.2	<i>Test setup</i>	37
5.6.3	<i>Test results</i>	39
5.7	CONDUCTION SPURIOUS EMISSION	46
5.7.1	<i>Limits</i>	46
5.7.2	<i>Test setup</i>	46
5.7.3	<i>Test procedure</i>	46
5.7.4	<i>Test results</i>	47
5.8	POWER SPECTRAL DENSITY	57
5.8.1	<i>Limit</i>	57
5.8.2	<i>Test procedure</i>	57
5.8.3	<i>Test setup</i>	58
5.8.4	<i>Test results</i>	59
5.9	FREQUENCY STABILITY MEASUREMENT	72



5.9.1 *Limit* 72
5.9.2 *Test Procedures* 72
5.9.3 *Test Setup Layout* 72
5.9.4 *EUT Operation during Test* 72
5.9.5 *TEST RESULTS* 73

PHOTOGRAPHS OF THE TEST SETUP..... 79

PHOTOGRAPHS OF THE EUT..... 81

Test Result Certification

Applicant's name: CHUWI TECHNOLOGY (ShenZhen) CO., LIMITED

Address: 2 Floor Building 3 LiJinCheng Industrial park the east of Gongye road LongHua Shenzhen China.

Manufacture's Name: CHUWI TECHNOLOGY (ShenZhen) CO., LIMITED

Address: 2 Floor Building 3 LiJinCheng Industrial park the east of Gongye road LongHua Shenzhen China.

Product name: Notebook

Trademark: CHUWI

Model name: CWI510, CWI533, CWI534, CWI535, CWI536, CWI560, CWI561, CWI562, CWI563, CWI564

Standards: FCC Part 15.407

Test Procedure: ANSI C63.10-2013
KDB 789033 D02 General UNII Test Procedures New Rules v02r01

This device described above has been tested by Shenzhen Microtest Co., Ltd. and the test results show that the equipment under test (EUT) compliance with the FCC requirements. And it is applicable only to the tested sample identified in the report.

Tested by:



Demi Mu

Aug. 28, 2019

Reviewed by:



Blue Zheng

Aug. 28, 2019

Approved by:



Smith Chen

Aug. 28, 2019

1 General information

1.1 Description of EUT

Equipment:		Notebook
Model name:		CWI510
Serial Model:		CWI533, CWI534, CWI535, CWI536, CWI560, CWI561, CWI562, CWI563, CWI564
Model difference:		All the model are the same circuit and RF module, except the model No. and color.
Frequency range:		U-NII-1: 5150 MHz to 5250 MHz, U-NII-3: 5725 MHz to 5850 MHz
Modulation type:		OFDM with BPSK/QPSK/16QAM/64QAM/256QAM for 802.11a/n/ac;
Transfer rate:		802.11a: 6,9,12,18,24,36,48,54Mbps; 802.11n(HT20/HT40): MCS0-MCS15; 802.11ac(VHT20): NSS1, MCS0-MCS8 802.11ac(VHT40):NSS1, MCS0-MCS9 802.11ac(VHT80) :NSS2,MCS0-MCS9;
Channel bandwidth:		802.11a: 20 MHz 802.11n: 20 MHz, 40 MHz 802.11ac: 20 MHz, 40 MHz, 80MHz
Antenna type:		FPC antenna
Antenna gain:	ANT A	U-NII-1: 0.58dBi U-NII-3:0.58dBi
	ANT B	U-NII-1: 0.58dBi U-NII-3:0.58dBi
Max. output power:		U-NII-1: 10.45dBm U-NII-3: 12.59dBm
Hardware version:		X133K REV1.1
Software version:		win10 home 1803
Power supply:		DC 7.6V from Battery or DC 12V from adapter
Adapter information:		Model:A241-1202000D Input:100-240V~ 50/60Hz 0.8A Output:12V 2A
Battery:		DC 7.6V 5000mAh

1.2 Operation channel list

For U-NII-1:

20 MHz		40 MHz		80 MHz	
Channel Number	Frequency (MHz)	Channel Number	Frequency (MHz)	Channel Number	Frequency (MHz)
36	5180	38	5190	42	5210
40	5200	46	5230	--	--
44	5220	--	--	--	--
48	5240	--	--	--	--

For U-NII-3:

20 MHz		40 MHz		80 MHz	
Channel Number	Frequency (MHz)	Channel Number	Frequency (MHz)	Channel Number	Frequency (MHz)
149	5745	151	5755	155	5775
153	5765	159	5795	--	--
157	5785	--	--	--	--
161	5805	--	--	--	--
165	5825	--	--	--	--

1.3 Test channel list

For 802.11a/n/ac (HT20)

U-NII-1 (5150 - 5250 MHz)			U-NII-3(5725 - 5850 MHz)		
Channel Number	Channel	Frequency (MHz)	Channel Number	Channel	Frequency (MHz)
36	Low	5180	149	Low	5745
44	Mid	5220	157	Mid	5785
48	High	5240	165	High	5825

80 MHz	
Channel Number	Frequency (MHz)
42	5210

For 802.11n/ac (HT40)

U-NII-1 (5150 - 5250 MHz)			U-NII-3(5725 - 5850 MHz)		
Channel Number	Channel	Frequency (MHz)	Channel Number	Channel	Frequency (MHz)
38	Low	5190	151	Low	5755
46	High	5230	159	High	5795

80 MHz	
Channel Number	Frequency (MHz)
155	5775



1.4 Ancillary equipment list

Equipment	Model	S/N	Manufacturer	Certificate type
/	/	/	/	/
/	/	/	/	/
/	/	/	/	/

1.5 Description of Support Units

The EUT has been tested as an independent unit together with other necessary accessories or support units. The following support units or accessories were used to form a representative test configuration during the tests.

Item	Equipment	Brand	Model/Type No.	Series No.	Note
1	Adapter	/	A241-1202000D	/	/
/	/	/	/	/	/

Note:

- (1)The support equipment was authorized by Declaration of Confirmation.
- (2)For detachable type I/O cable should be specified the length in cm in 『Length』 column.

2 Summary of the Test Results

Test procedures according to the technical standards:

No.	Standard Section	Test Item	Result	Remark
1	15.203/15.407	Antenna Requirement	Pass	
2	15.407(a)	RF Output Power	Pass	
3	15.207	Power Line Conducted Emission	Pass	
4	15.407(a)	26dB Emission Bandwidth and Occupied bandwidth	Pass	
5	15.407(e)	6 dB bandwidth	Pass	
6	15.407(a)	Power Spectral Density	Pass	
7	15.407(b) 15.209	Radiation Spurious Emission	Pass	
8	15.407(b) 15.209	Conducted Spurious Emission	Pass	
9	15.407(g)	Frequency stability	Pass	



3 Test Facilities and Accreditations

3.1 Test laboratory

Test Laboratory	Shenzhen Microtest Co., Ltd
Location	No.102A & 302A, East Block, Hengfang Industrial Park, Xingye Road, Xixiang, Bao'an District, Shenzhen, Guangdong, China
FCC Registration No.:	448573

3.2 Environmental conditions

Temperature:	15°C~35°C
Humidity	20%~75%
Atmospheric pressure	98kPa~101kPa

3.3 Measurement uncertainty

The reported uncertainty of measurement $y \pm U$, where expanded uncertainty U is based on a standard uncertainty multiplied by a coverage factor of $k=2$, providing a level of confidence of approximately 95 %

No.	Item	Uncertainty
1	Conducted Emission Test	$\pm 1.38\text{dB}$
2	RF power, conducted	$\pm 0.16\text{dB}$
3	Spurious emissions, conducted	$\pm 0.21\text{dB}$
4	All emissions, radiated(<1G)	$\pm 4.68\text{dB}$
5	All emissions, radiated(>1G)	$\pm 4.89\text{dB}$
6	Temperature	$\pm 0.5^{\circ}\text{C}$
7	Humidity	$\pm 2\%$

3.4 Test software

Software Name	Manufacturer	Model	Version
Bluetooth and WiFi Test System	Shenzhen JS tonscond co., ltd	JS1120-3	2.5.77.0418

4 Equipment list

Equipment No.	Equipment Name	Manufacturer	Model	Serial No.	Calibration date	Due date
MTI-E004	EMI Test Receiver	Rohde&schwarz	ESPI7	100314	2018/10/09	2019/10/08
MTI-E006	TRILOG Broadband Antenna	schwarzbeck	VULB 9163	9163-872	2018/10/15	2020/10/14
MTI-E014	amplifier	Hewlett-Packard	8447D	3113A06150	2018/10/09	2019/10/08
MTI-E036	Single path vehicle AMN(LISN)	Schwarzbeck	NNBM 8124	01175	2018/10/09	2019/10/08
MTI-E038	Low noise active vertical monopole antenna	Schwarzbeck	VAMP 9243	#565	2018/10/16	2019/10/15
MTI-E039	Biconical antenna	Schwarzbeck	BBA 9106	#164	2018/10/15	2019/10/14
MTI-E041	MXG Vector Signal Generator	Agilent	N5182A	MY49060455	2019/04/16	2020/04/15
MTI-E042	ESG Series Analog signal generator	Agilent	E4421B	GB40051240	2019/05/21	2020/05/20
MTI-E044	Thermometer clock humidity monitor	-	HTC-1	/	2019/04/17	2020/04/16
MTI-E062	Log Periodic Antenna	Schwarzbeck	VUSLP 9111B	#312	2018/04/11	2020/04/10
MTI-E063	Log Periodic Dipole Array Antenna	ETS-LINDGREN	3148B	00224524	2018/04/11	2020/04/10
MTI-E065	Amplifier	EMtrace	RP06A	00117	2019/04/29	2020/04/28
MTI-E071	PXA Signal Analyzer	Agilent	N9030A	MY51350296	2018/10/25	2019/10/24
MTI-E076	EMI Test Receiver	Rohde&schwarz	ESIB26	100273	2019/04/16	2020/04/15
MTI-E078	Synthesized Sweeper	Agilent	83752A	3610A01957	2019/04/16	2020/04/15
MTI-E079	DC Power Supply	Agilent	E3632A	MY40027695	2019/04/16	2020/04/15
MTI-E092	DC power source	shenzhen tongyuan	TY-500V 100A	201710190325689	2019/4/16	2020/4/15
MTI-E093	Artificial mains network	3ctest	LISN J50	ES3911805	2019/04/16	2020/04/15
MTI-E096	Power amplifier	Space-Dtronics	EWLNA0118G-P40	1852001	2019/04/29	2020/04/28
MTI-E097	Current Probe	SOLAR ELECTRONICS CO.	9207-1	220095-1	2019/04/17	2020/04/16
MTI-E098	Loop Sensor	SOLAR ELECTRONICS CO.	7334-1	220095-2	2019/04/21	2020/04/20
MTI-E0123	High and low temperature box	Heron	JHY-HT-80L	LGD-GDW-80	2019/4/16	2020/4/15

Note: the calibration interval of the above test instruments is 12 months and the calibrations are traceable to international system unit (SI).

5 Test Results

5.1 Antenna requirement

5.1.1 Standard requirement

15.203 requirement: For intentional device, according to 15.203: an intentional radiator shall be designed to ensure that no antenna other than that furnished by the responsible party shall be used with the device.

5.1.2 EUT Antenna

The antenna is FPC antenna, which was permanently affixed to the device and un-replaced, complies with 15.203. In addition, the maximum antenna gain is 0.58 dBi.

5.2 RF output power

5.2.1 Limit

For the 5.15-5.25 GHz band

For client devices in the 5.15-5.25 GHz band, the maximum conducted output power over the frequency band of operation shall not exceed 250 mW provided the maximum antenna gain does not exceed 6 dBi. In addition, the maximum power spectral density shall not exceed 11 dBm in any 1 megahertz band. If transmitting antennas of directional gain greater than 6 dBi are used, both the maximum conducted output power and the maximum power spectral density shall be reduced by the amount in dB that the directional gain of the antenna exceeds 6 dBi.

For the 5.25-5.35 GHz and 5.47-5.725 GHz band

For the 5.25-5.35 GHz and 5.47-5.725 GHz bands, the maximum conducted output power over the frequency bands of operation shall not exceed the lesser of 250 mW or $11 \text{ dBm} + 10 \log B$, where B is the 26 dB emission bandwidth in megahertz. In addition, the maximum power spectral density shall not exceed 11 dBm in any 1 megahertz band. If transmitting antennas of directional gain greater than 6 dBi are used, both the maximum conducted output power and the maximum power spectral density shall be reduced by the amount in dB that the directional gain of the antenna exceeds 6 dBi.

For the band 5.725-5.85 GHz

The maximum conducted output power over the frequency band of operation shall not exceed 1 W. If transmitting antennas of directional gain greater than 6 dBi are used, the maximum conducted output power shall be reduced by the amount in dB that the directional gain of the antenna exceeds 6 dBi.

5.2.2 Test procedure

The maximum peak conducted output power may be measured using a broadband Average RF power meter. The power meter shall have a video bandwidth that is greater than or equal to the emission bandwidth and utilize a fast-responding diode detector.

5.2.3 Test setup

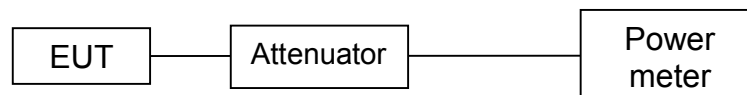

5.2.4 Test results

Note 1: For FCC standard, if transmitting antennas of directional gain greater than 6 dBi are used, all band maximum conducted output power shall be reduced by the amount in dB that the directional gain of the antenna exceeds 6 dBi.

For U-NII-1

Modulation mode	Test Channel	Frequency (MHz)	Maximum Peak Conducted Power						Limit (mW)
			ANT A		ANT B		Total power of antennas		
			(dBm)	(mW)	(dBm)	(mW)	(dBm)	(mW)	
11a	CH36	5180	10.15	10.35	10.21	10.50	13.19	20.85	250
11a	CH40	5200	10.10	10.23	10.34	10.81	13.23	21.05	250
11a	CH48	5240	10.45	11.09	10.33	10.79	13.40	21.88	250
11n(HT20)	CH36	5180	9.93	9.84	10.34	10.81	13.15	20.65	250
11n (HT20)	CH40	5200	9.97	9.93	10.28	10.67	13.14	20.60	250
11n (HT20)	CH48	5240	10.34	10.81	9.08	8.09	12.77	18.91	250
11n (HT40)	CH38	5190	8.96	7.87	9.20	8.32	12.09	16.19	250
11n (HT40)	CH46	5230	8.37	6.87	8.36	6.85	11.38	13.73	250

Modulation mode	Test Channel	Frequency (MHz)	Maximum Peak Conducted Power						Limit (mW)
			ANT A		ANT B		Total power of antennas		
			(dBm)	(mW)	(dBm)	(mW)	(dBm)	(mW)	
11ac (HT20)	CH36	5180	8.03	6.35	8.30	6.76	11.18	13.11	250
11ac (HT20)	CH40	5200	7.07	5.09	8.12	6.49	10.64	11.58	250
11ac (HT20)	CH48	5240	7.18	5.22	8.24	6.67	10.75	11.89	250
11ac (HT40)	CH38	5190	6.25	4.22	6.57	4.54	9.42	8.76	250
11ac (HT40)	CH46	5230	6.75	4.73	7.16	5.20	9.97	9.93	250
11ac (HT80)	CH46	5230	6.78	4.76	7.69	5.87	10.27	10.63	250

For U-NII-3

Modulation mode	Test Channel	Frequency (MHz)	Maximum Peak Conducted Power						Limit (mW)
			ANT A		ANT B		Total power of antennas		
			(dBm)	(mW)	(dBm)	(mW)	(dBm)	(mW)	
11a	CH36	5180	12.31	17.02	10.37	10.89	14.46	27.91	1000
11a	CH40	5200	12.06	16.07	10.58	11.43	14.39	27.50	1000
11a	CH48	5240	11.90	15.49	11.80	15.14	14.86	30.63	1000
11n (HT20)	CH36	5180	12.59	18.16	12.37	17.26	15.49	35.42	1000
11n (HT20)	CH40	5200	11.95	15.67	10.19	10.45	14.17	26.12	1000
11n (HT20)	CH48	5240	11.76	15.00	10.76	11.91	14.30	26.91	1000
11n (HT40)	CH38	5190	10.35	10.84	11.00	12.59	13.70	23.43	1000
11n (HT40)	CH46	5230	10.84	12.13	12.03	15.96	14.49	28.09	1000

Modulation mode	Test Channel	Frequency (MHz)	Maximum Peak Conducted Power						Limit (mW)
			ANT A		ANT B		Total power of antennas		
			(dBm)	(mW)	(dBm)	(mW)	(dBm)	(mW)	
11ac (HT20)	CH36	5180	4.64	2.91	4.36	2.73	7.51	5.64	1000
11ac (HT20)	CH40	5200	4.12	2.58	4.25	2.66	7.19	5.24	1000
11ac (HT20)	CH48	5240	4.75	2.99	4.64	2.91	7.71	5.90	1000
11ac (HT40)	CH38	5190	4.60	2.88	4.38	2.74	7.50	5.62	1000
11ac (HT40)	CH46	5230	4.09	2.56	4.98	3.15	7.56	5.71	1000
11ac (HT80)	CH46	5230	4.71	2.96	4.19	2.62	7.47	5.58	1000

5.3 Power line conducted emission

5.3.1 Limits

FREQUENCY (MHz)	Class B (dBuV)	
	Quasi-peak	Average
0.15 -0.5	66 - 56 *	56 - 46 *
0.50 -5.0	56.00	46.00
5.0 -30.0	60.00	50.00

Note

(1)The tighter limit applies at the band edges.

(2)The limit of " * " marked band means the limitation decreases linearly with the logarithm of the frequency in the range.

5.3.2 Test setup

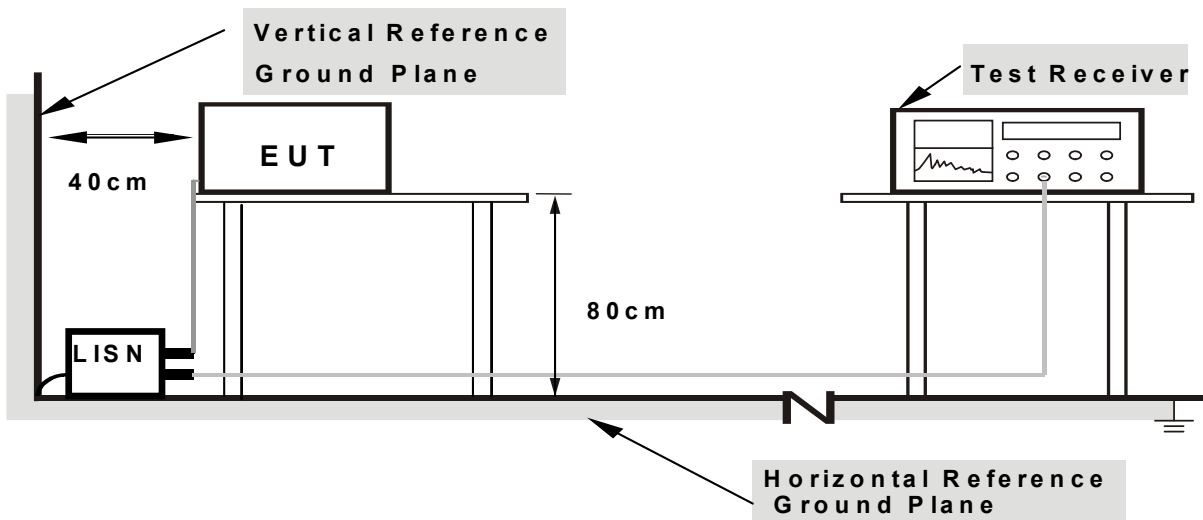

Note: 1.Support units were connected to second LISN.

2.Both of LISNs (AMN) are 80 cm from EUT and at least 80 from other units and other metal planes

5.3.3 Test procedure

a. EUT Operating Conditions

The EUT was configured for testing in a typical fashion (as a customer would normally use it). The EUT has been programmed to continuously transmit during test. This operating condition was tested and used to collect the included data.

b. The following table is the setting of the receiver

Receiver Parameters	Setting
Attenuation	10 dB
Start Frequency	0.15 MHz
Stop Frequency	30 MHz
IF Bandwidth	9 kHz

- c. The EUT was placed 0.8 meters from the horizontal ground plane with EUT being connected to the power mains through a line impedance stabilization network (LISN). All other support equipment's powered from additional LISN(s). The LISN provide 50 Ohm/ 50uH of coupling impedance for the measuring instrument.
- d. Interconnecting cables that hang closer than 40 cm to the ground plane shall be folded back and forth in the center forming a bundle 30 to 40 cm long.
- e. I/O cables that are not connected to a peripheral shall be bundled in the center. The end of the cable may be terminated, if required, using the correct terminating impedance. The overall length shall not exceed 1 m.
- f. LISN at least 80 cm from nearest part of EUT chassis.

For the actual test configuration, please refer to the related Item –EUT Test Photos.

5.3.4 Test results

EUT:	Notebook	Model Name. :	CWI510
Pressure:	1010hPa	Phase:	L
Test Voltage:	DC 12V from adapter AC 120V/60Hz	Test Mode:	Charging+TX

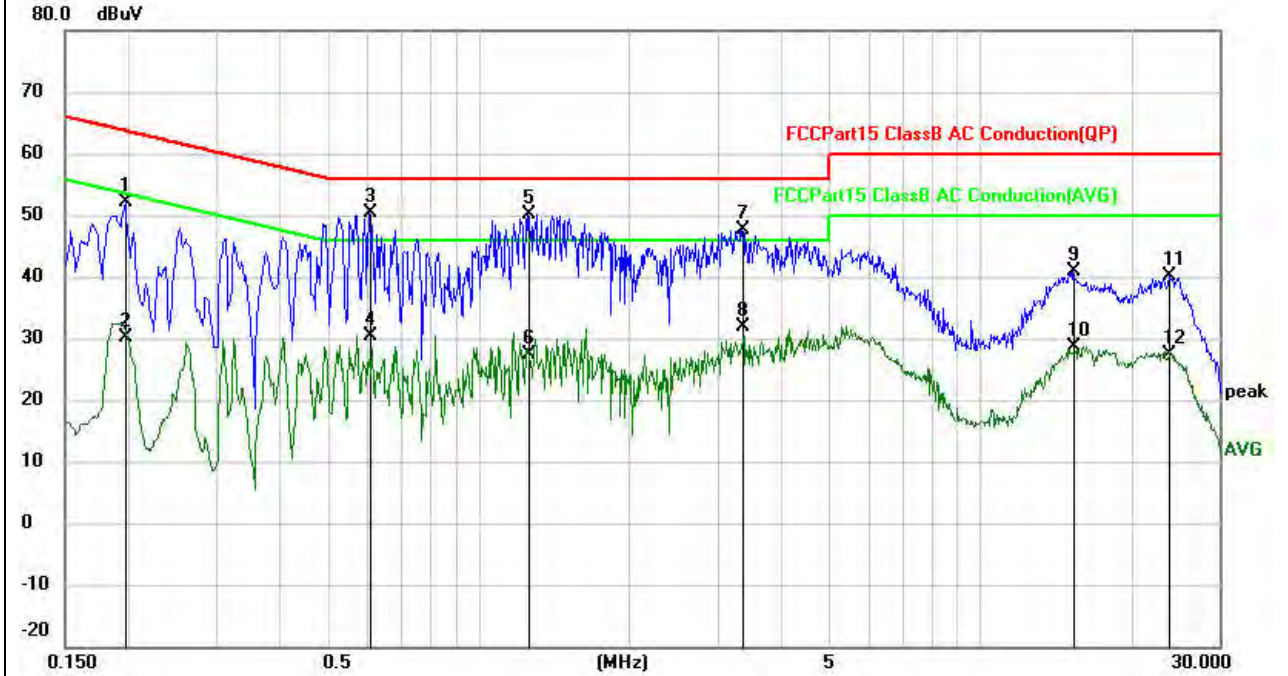

No.	Mk.	Freq. MHz	Reading Level dBuV	Correct Factor dB	Measure- ment dBuV	Limit dBuV	Over dB	Detector	Comment
1		0.1980	42.44	9.73	52.17	63.69	-11.52	QP	
2		0.1980	20.35	9.73	30.08	53.69	-23.61	AVG	
3	*	0.6058	40.58	9.89	50.47	56.00	-5.53	QP	
4		0.6058	20.49	9.89	30.38	46.00	-15.62	AVG	
5		1.2579	40.14	9.96	50.10	56.00	-5.90	QP	
6		1.2579	17.52	9.96	27.48	46.00	-18.52	AVG	
7		3.3540	37.72	10.01	47.73	56.00	-8.27	QP	
8		3.3540	21.85	10.01	31.86	46.00	-14.14	AVG	
9		15.3658	30.61	10.18	40.79	60.00	-19.21	QP	
10		15.3658	18.40	10.18	28.58	50.00	-21.42	AVG	
11		23.8100	29.89	10.20	40.09	60.00	-19.91	QP	
12		23.8100	17.22	10.20	27.42	50.00	-22.58	AVG	

EUT:	Notebook	Model Name. :	CWI510
Pressure:	1010hPa	Phase:	N
Test Voltage:	DC 12V from adapter AC 120V/60Hz	Test Mode:	Charging+TX

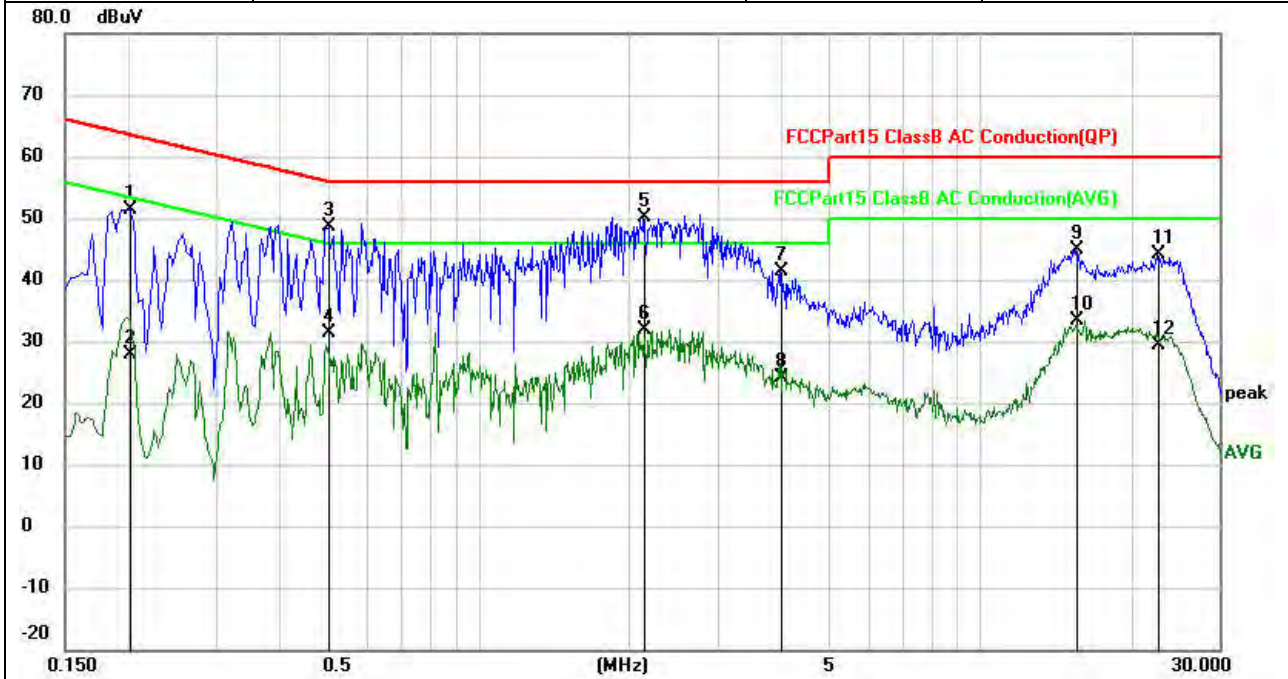

No.	Mk.	Freq.	Reading Level	Correct Factor	Measurement	Limit	Over	Detector	Comment
		MHz	dBuV	dB	dBuV	dBuV	dB		
1		0.2020	41.69	9.73	51.42	63.53	-12.11	QP	
2		0.2020	18.11	9.73	27.84	53.53	-25.69	AVG	
3		0.5020	38.68	9.88	48.56	56.00	-7.44	QP	
4		0.5020	21.55	9.88	31.43	46.00	-14.57	AVG	
5	*	2.1339	40.21	9.98	50.19	56.00	-5.81	QP	
6		2.1339	21.97	9.98	31.95	46.00	-14.05	AVG	
7		4.0060	31.42	10.03	41.45	56.00	-14.55	QP	
8		4.0060	14.12	10.03	24.15	46.00	-21.85	AVG	
9		15.4977	34.64	10.18	44.82	60.00	-15.18	QP	
10		15.4977	23.14	10.18	33.32	50.00	-16.68	AVG	
11		22.5858	33.94	10.16	44.10	60.00	-15.90	QP	
12		22.5858	19.24	10.16	29.40	50.00	-20.60	AVG	



EUT:	Notebook	Model Name:	CWI510
Pressure:	1010hPa	Phase :	L
Test Voltage:	DC 12V from adapter AC 240V/60Hz	Test Mode:	Charging+TX

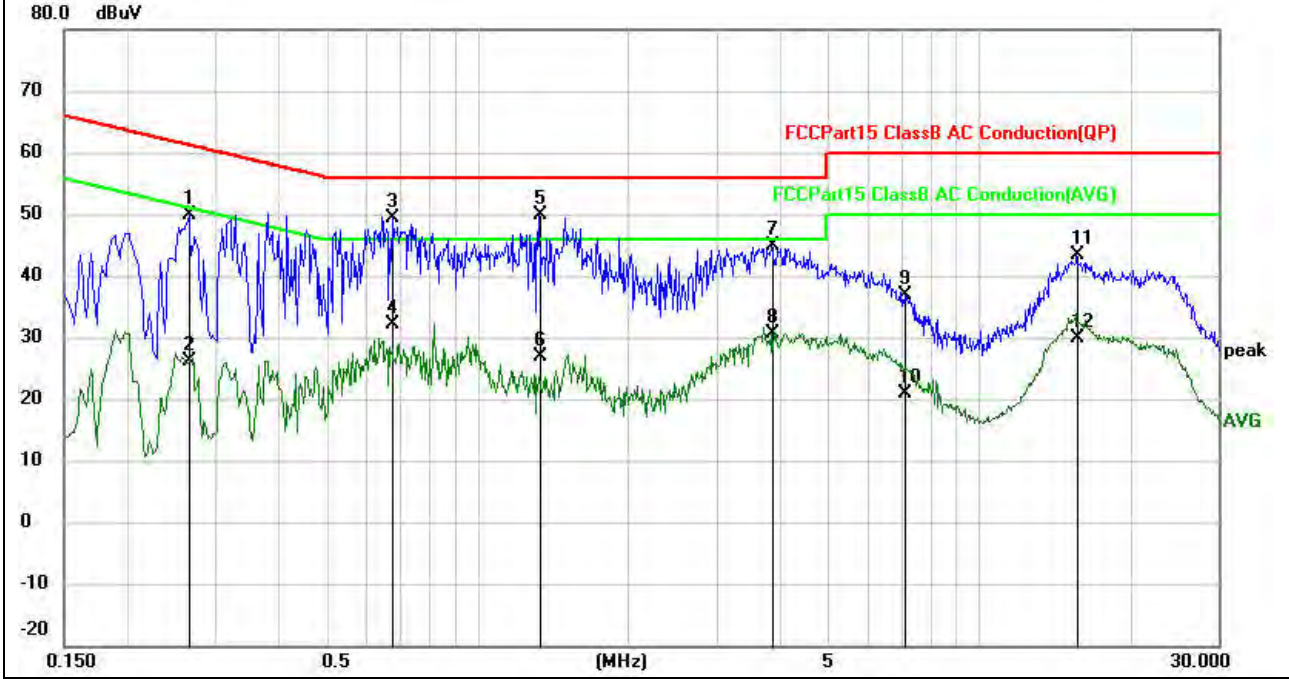

No.	Mk.	Freq.	Reading Level	Correct Factor	Measurement	Limit	Over	Detector	Comment
		MHz	dBuV	dB	dBuV	dBuV	dB		
1		0.2660	40.25	9.74	49.99	61.24	-11.25	QP	
2		0.2660	16.41	9.74	26.15	51.24	-25.09	AVG	
3		0.6780	39.42	9.90	49.32	56.00	-6.68	QP	
4		0.6780	22.11	9.90	32.01	46.00	-13.99	AVG	
5	*	1.3260	39.83	9.96	49.79	56.00	-6.21	QP	
6		1.3260	17.04	9.96	27.00	46.00	-19.00	AVG	
7		3.8740	34.75	10.02	44.77	56.00	-11.23	QP	
8		3.8740	20.71	10.02	30.73	46.00	-15.27	AVG	
9		7.1177	26.78	10.15	36.93	60.00	-23.07	QP	
10		7.1177	10.74	10.15	20.89	50.00	-29.11	AVG	
11		15.7139	33.23	10.18	43.41	60.00	-16.59	QP	
12		15.7139	19.82	10.18	30.00	50.00	-20.00	AVG	



EUT:	Notebook	Model Name. :	CWI510
Pressure:	1010hPa	Phase:	N
Test Voltage:	DC 12V from adapter AC 240V/60Hz	Test Mode:	Charging+TX

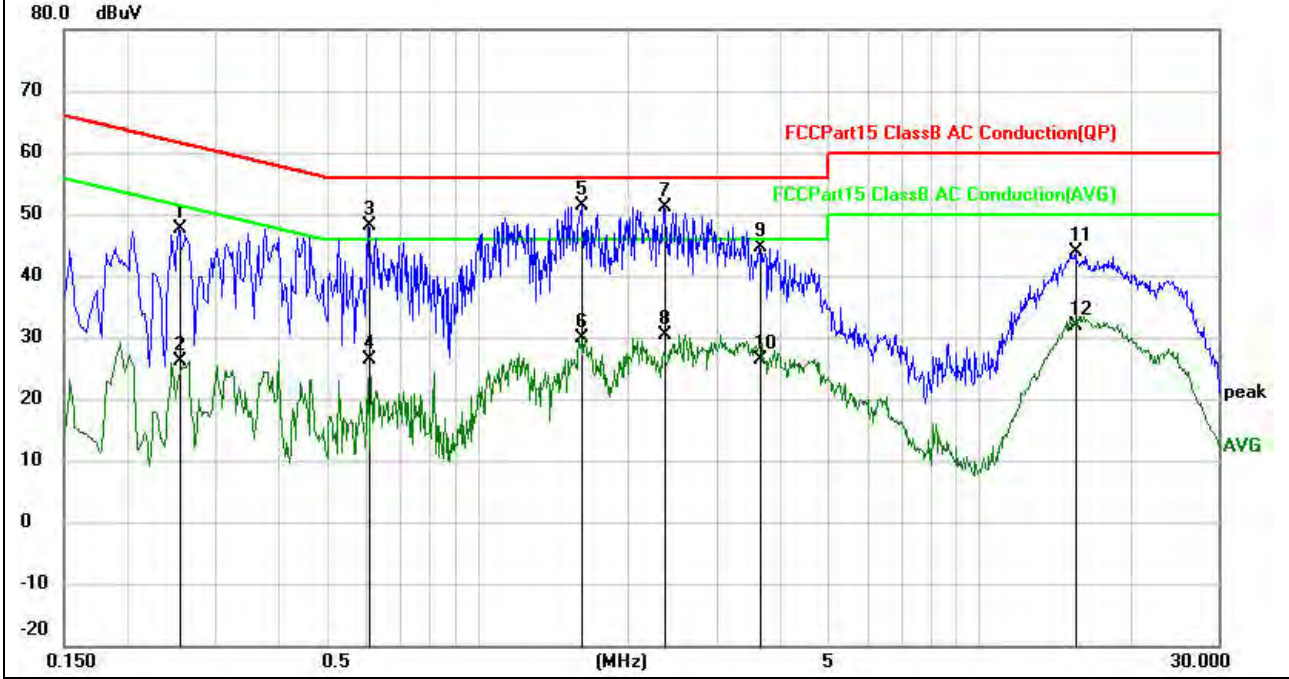

No.	Mk.	Freq. MHz	Reading Level dBuV	Correct Factor dB	Measure- ment dBuV	Limit dBuV	Over dB	Detector	Comment
1		0.2540	37.85	9.73	47.58	61.63	-14.05	QP	
2		0.2540	16.32	9.73	26.05	51.63	-25.58	AVG	
3		0.6058	38.36	9.89	48.25	56.00	-7.75	QP	
4		0.6058	16.47	9.89	26.36	46.00	-19.64	AVG	
5	*	1.6140	41.50	9.96	51.46	56.00	-4.54	QP	
6		1.6140	19.95	9.96	29.91	46.00	-16.09	AVG	
7		2.3580	41.23	9.98	51.21	56.00	-4.79	QP	
8		2.3580	20.48	9.98	30.46	46.00	-15.54	AVG	
9		3.6459	34.54	10.02	44.56	56.00	-11.44	QP	
10		3.6459	16.44	10.02	26.46	46.00	-19.54	AVG	
11		15.5859	33.67	10.18	43.85	60.00	-16.15	QP	
12		15.5859	21.72	10.18	31.90	50.00	-18.10	AVG	

5.4 26dB Emission Bandwidth and Occupied bandwidth

5.4.1 Limit

For purposes of this subpart the emission bandwidth shall be determined by measuring the width of the signal between two points, one below the carrier center frequency and one above the carrier center frequency, that are 26 dB down relative to the maximum level of the modulated carrier

5.4.2 Test procedure

26d Emission bandwidth

Set RBW = approximately 1% of the emission bandwidth.

Set VBW $\geq 3 \times$ RBW

Detector = Peak.

Trace mode = Max hold.

Measure the maximum width of the emission that is 26 dB down from the peak of the emission.

Occupied Bandwidth

Set Span = 1.5 times to 5.0 times the OBW

Set RBW = 1% to 5% of the OBW.

Set VBW $\geq 3 \times$ RBW, Detector = Peak.

Trace mode = Max hold.

Use the 99% power bandwidth function of the instrument.

5.4.3 Test setup



5.4.4 Test results

Note1: The antenna A and antenna B have been tested. The report only shows the worst antenna. The worst case is ANT A.

ANT A

For U-NII-1

Channel	Test Channel	Frequency(MHz)	26dB bandwidth(MHz)	99% bandwidth (MHz)	Limit(kHz)	Result
11a	CH36	5180	23.25	17.069	/	Pass
11a	CH40	5200	26.77	17.110	/	Pass
11a	CH48	5240	23.12	17.041	/	Pass
11n (HT20)	CH36	5180	24.04	18.190	/	Pass
11n (HT20)	CH40	5200	28.14	18.187	/	Pass
11n (HT20)	CH48	5240	24.62	18.082	/	Pass
11n (HT40)	CH38	5190	42.70	36.378	/	Pass
11n (HT40)	CH46	5230	65.01	36.676	/	Pass

Channel	Test Channel	Frequency (MHz)	26dB bandwidth(MHz)	99% bandwidth(MHz)	Limit(kHz)	Result
11ac (HT20)	CH36	5180	31.30	18.131	/	Pass
11ac (HT20)	CH40	5200	24.20	17.955	/	Pass
11ac (HT20)	CH48	5240	24.01	17.985	/	Pass
11ac (HT40)	CH38	5190	43.05	36.246	/	Pass
11ac (HT40)	CH46	5230	43.33	36.241	/	Pass
11ac (HT80)	CH46	5230	81.53	75.202	/	Pass

For U-NII-3

Channel	Test Channel	Frequency(MHz)	99% bandwidth(MHz)	Limit(kHz)	Result
11a	CH149	5745	16.892	/	Pass
11a	CH157	5785	17.039	/	Pass
11a	CH165	5825	17.151	/	Pass
11n (HT20)	CH149	5745	17.998	/	Pass
11n (HT20)	CH157	5785	18.119	/	Pass
11n (HT20)	CH165	5825	18.253	/	Pass
11n (HT40)	CH151	5755	36.317	/	Pass
11n (HT40)	CH159	5795	36.544	/	Pass

Channel	Test Channel	Frequency(MHz)	99% bandwidth(MHz)	Limit(kHz)	Result
11ac (HT20)	CH149	5745	18.017	/	Pass
11ac (HT20)	CH157	5785	17.998	/	Pass
11ac (HT20)	CH165	5825	18.025	/	Pass
11ac (HT40)	CH151	5755	36.318	/	Pass
11ac (HT40)	CH159	5795	36.381	/	Pass
11ac (HT80)	CH159	5795	48.498	/	Pass

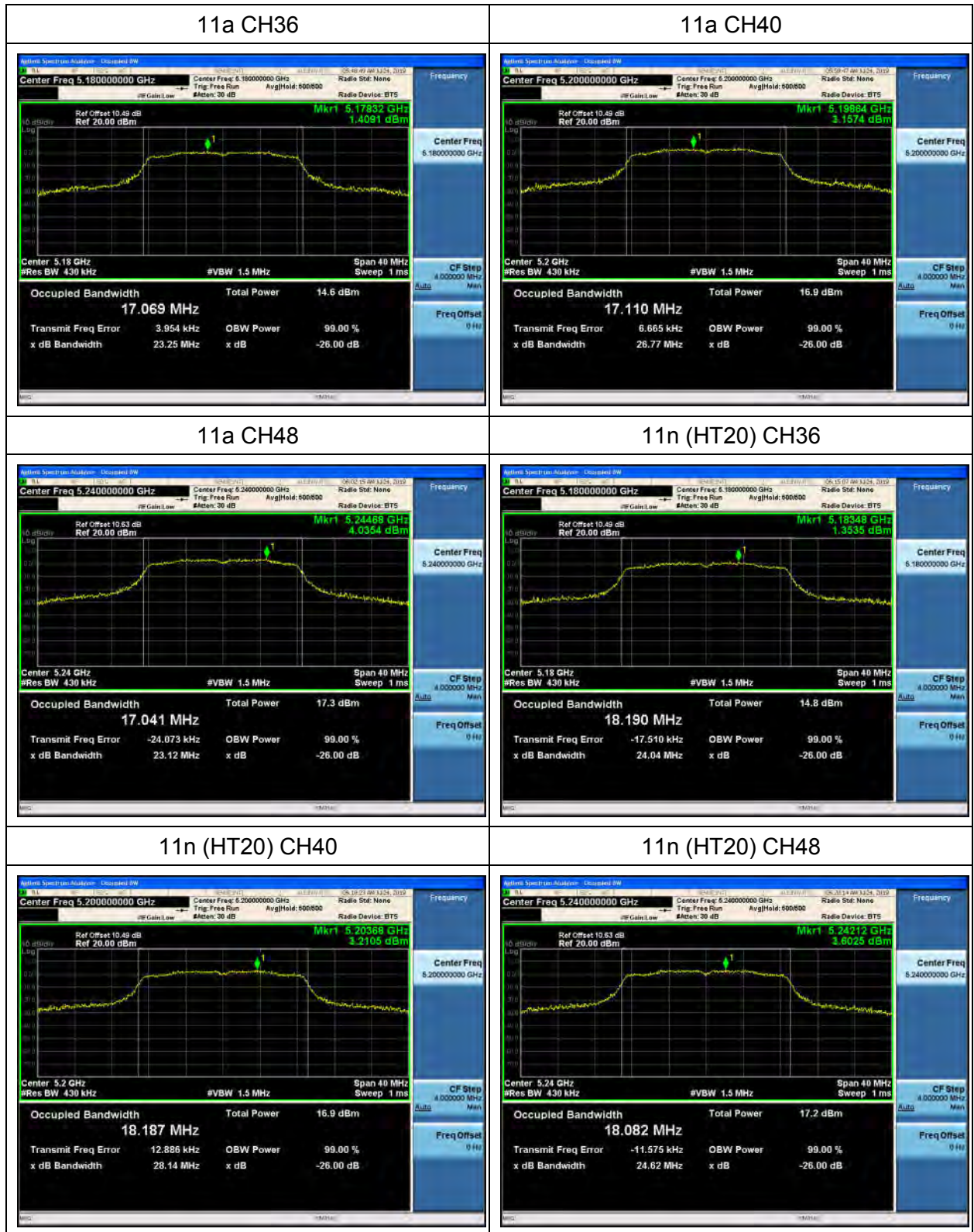
Test plots:
 For U-NII-1

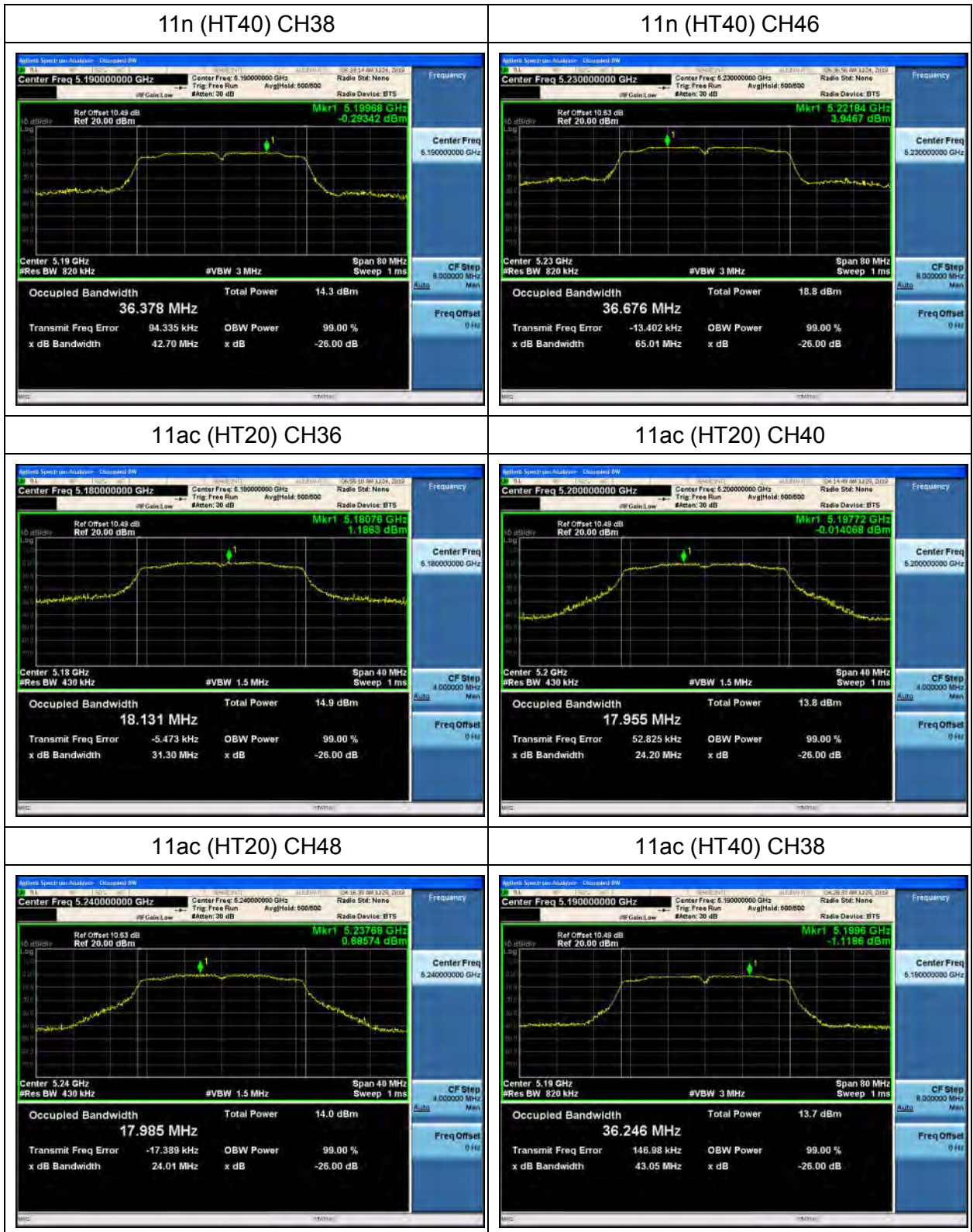

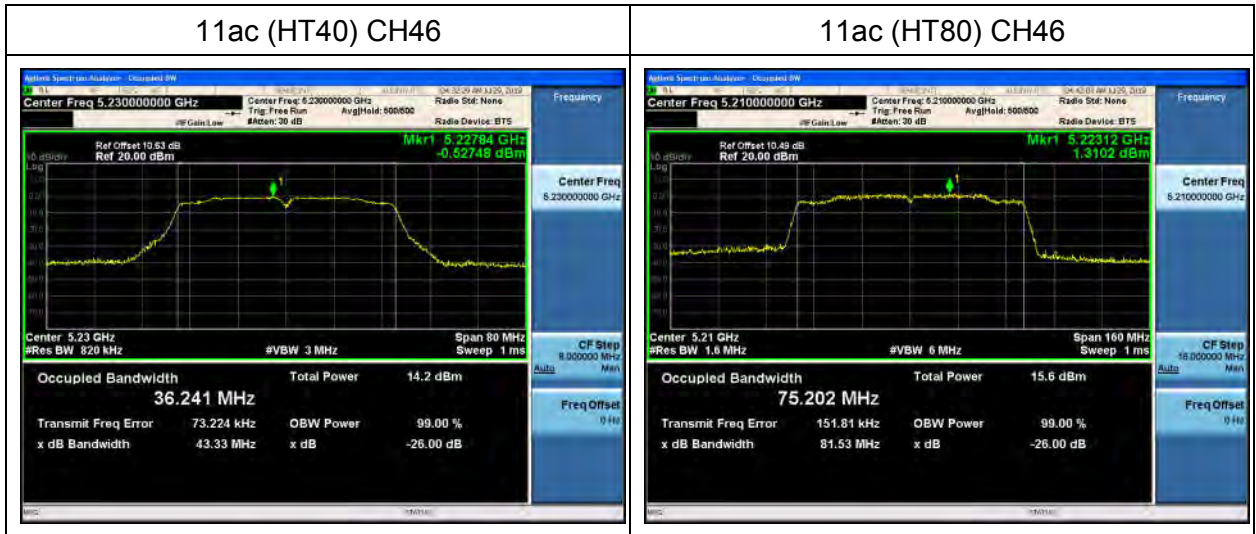

For U-NII-3

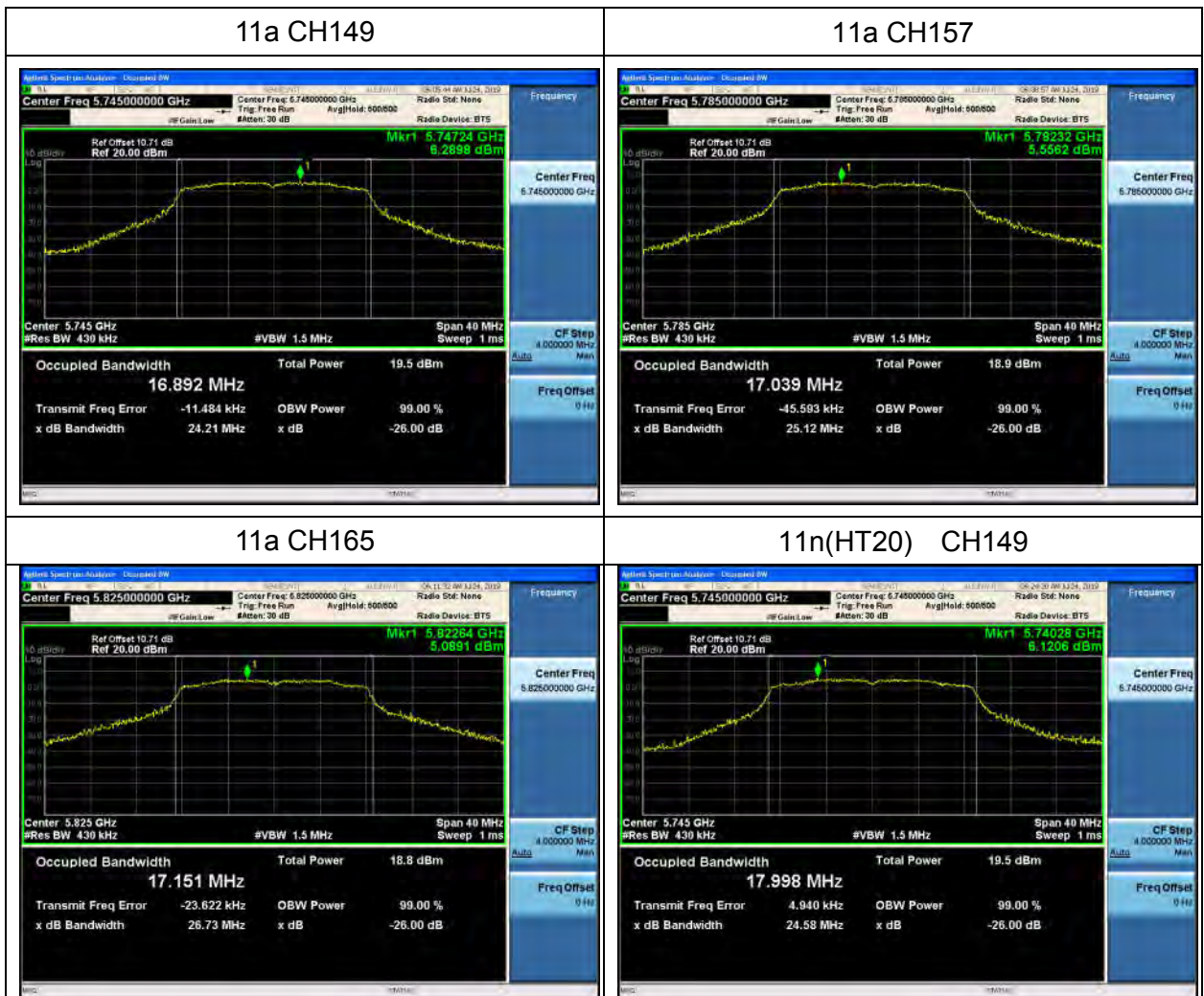

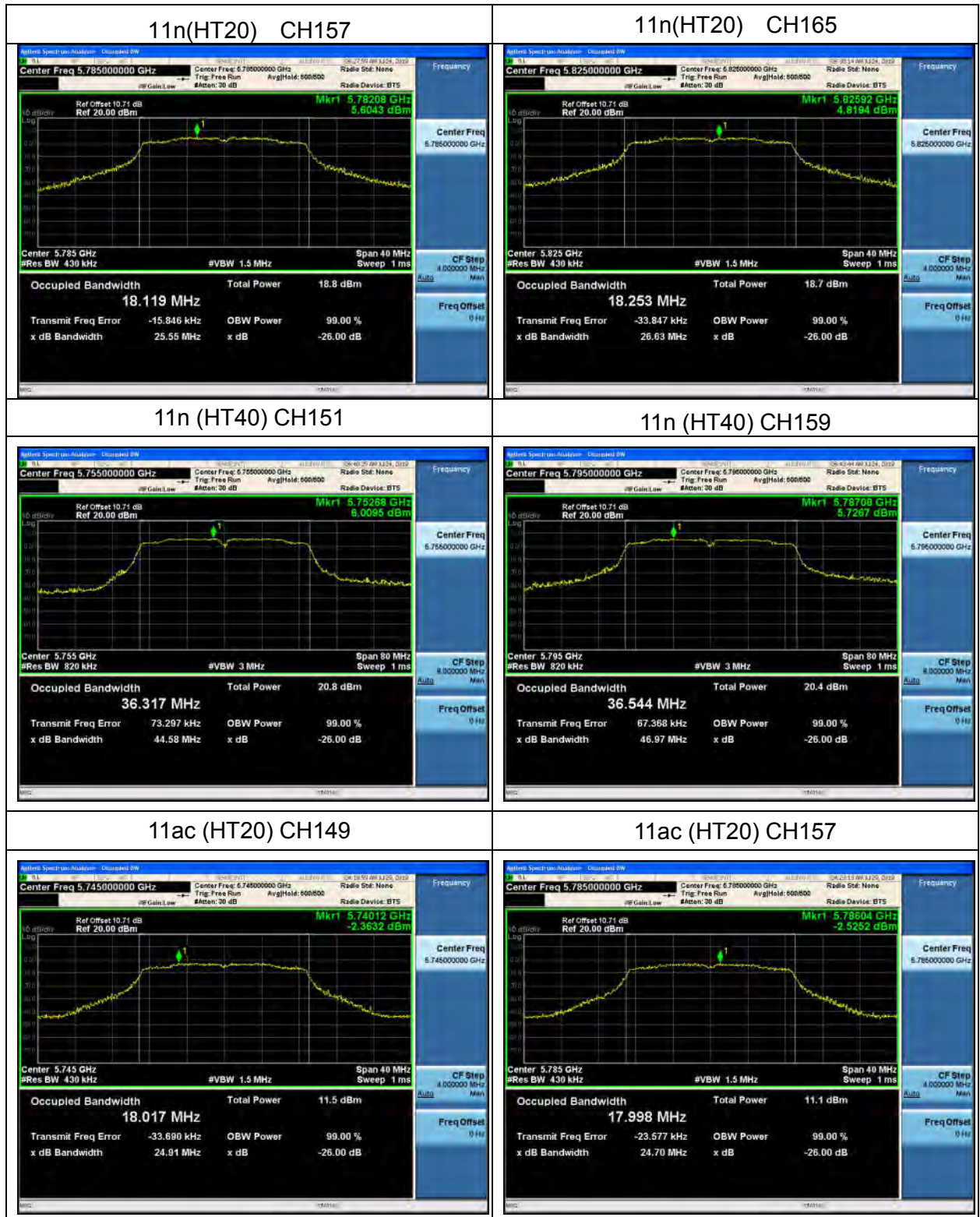

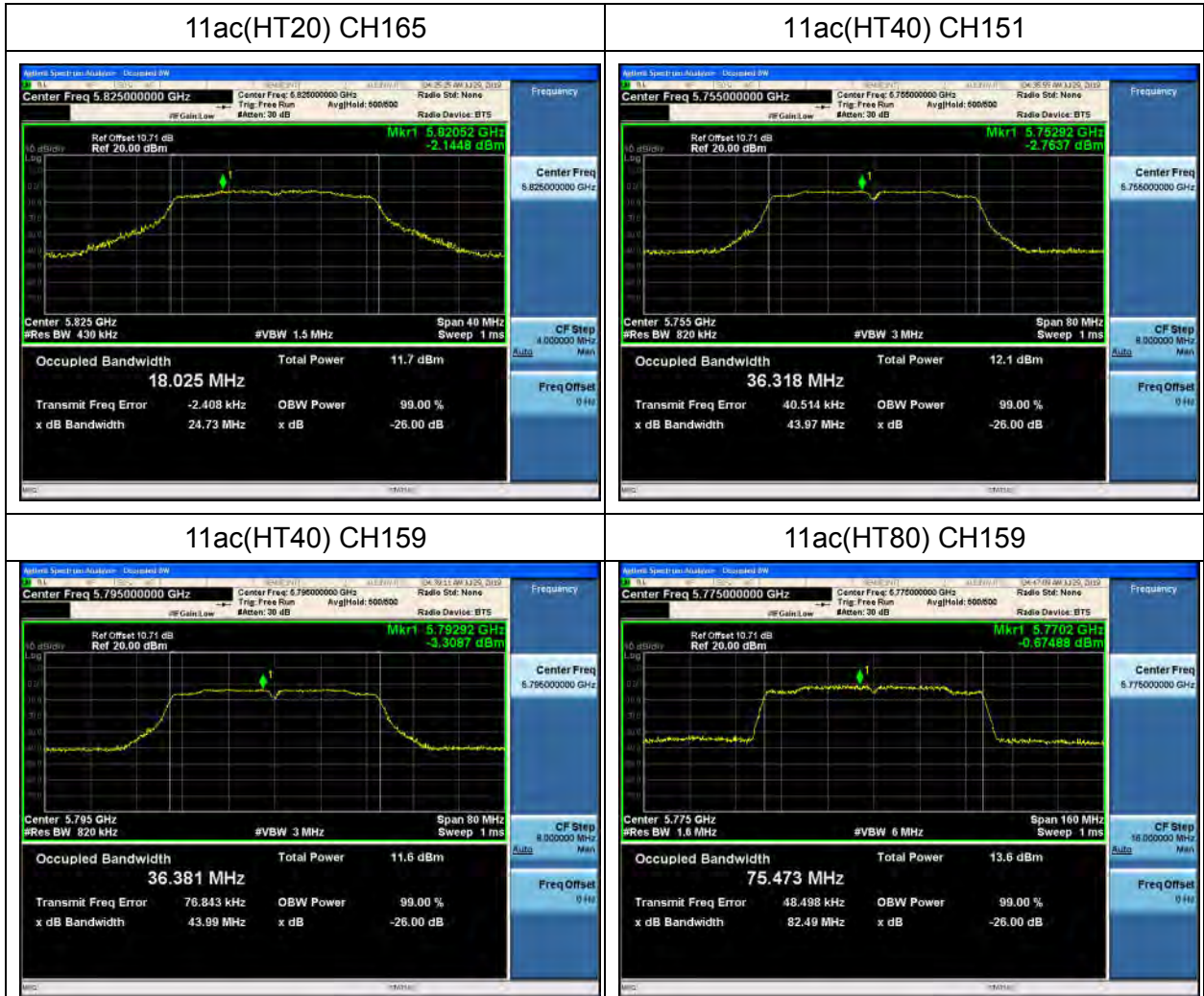

5.5 6dB Bandwidth

5.5.1 Limit

For purposes of this subpart the emission bandwidth shall be determined by measuring the width of the signal between two points, one below the carrier center frequency and one above the carrier center frequency, that are 26 dB down relative to the maximum level of the modulated carrier

5.5.2 Test procedure

1. Set RBW= 100 kHz.
2. Set the Video bandwidth (VBW) $\geq 3 \times$ RBW.
3. Detector = Peak.
4. Trace mode = max hold.
5. Sweep = auto couple.
6. Allow the trace to stabilize.
7. Measure the maximum width of the emission that is constrained by the frequencies associated with the two outermost amplitude points (upper and lower) that are attenuated by 26 dB relative to the maximum level measured in the fundamental emission.

5.5.3 Test setup



5.5.4 Test results

Note1: The antenna A and antenna B have been tested. The report only shows the worst antenna. The worst case is ANT A.

ANT A
For U-NII-3

Channel	Test Channel	Frequency(MHz)	6dB bandwidth(MHz)	Limit(kHz)	Result
11a	CH149	5745	15.56	500	Pass
11a	CH157	5785	15.48	500	Pass
11a	CH165	5825	15.16	500	Pass
11n (HT20)	CH149	5745	15.20	500	Pass
11n (HT20)	CH157	5785	15.44	500	Pass
11n (HT20)	CH165	5825	15.52	500	Pass
11n (HT40)	CH151	5755	35.28	500	Pass
11n (HT40)	CH159	5795	35.28	500	Pass

Channel	Test Channel	Frequency(MHz)	6dB bandwidth(MHz)	Limit(kHz)	Result
11ac (HT20)	CH149	5745	15.56	500	Pass
11ac (HT20)	CH157	5785	15.16	500	Pass
11ac (HT20)	CH165	5825	15.16	500	Pass
11ac (HT40)	CH151	5755	35.28	500	Pass
11ac (HT40)	CH159	5795	35.28	500	Pass
11ac (HT80)	CH159	5795	75.52	500	Pass

Test plots:

For U-NII-3

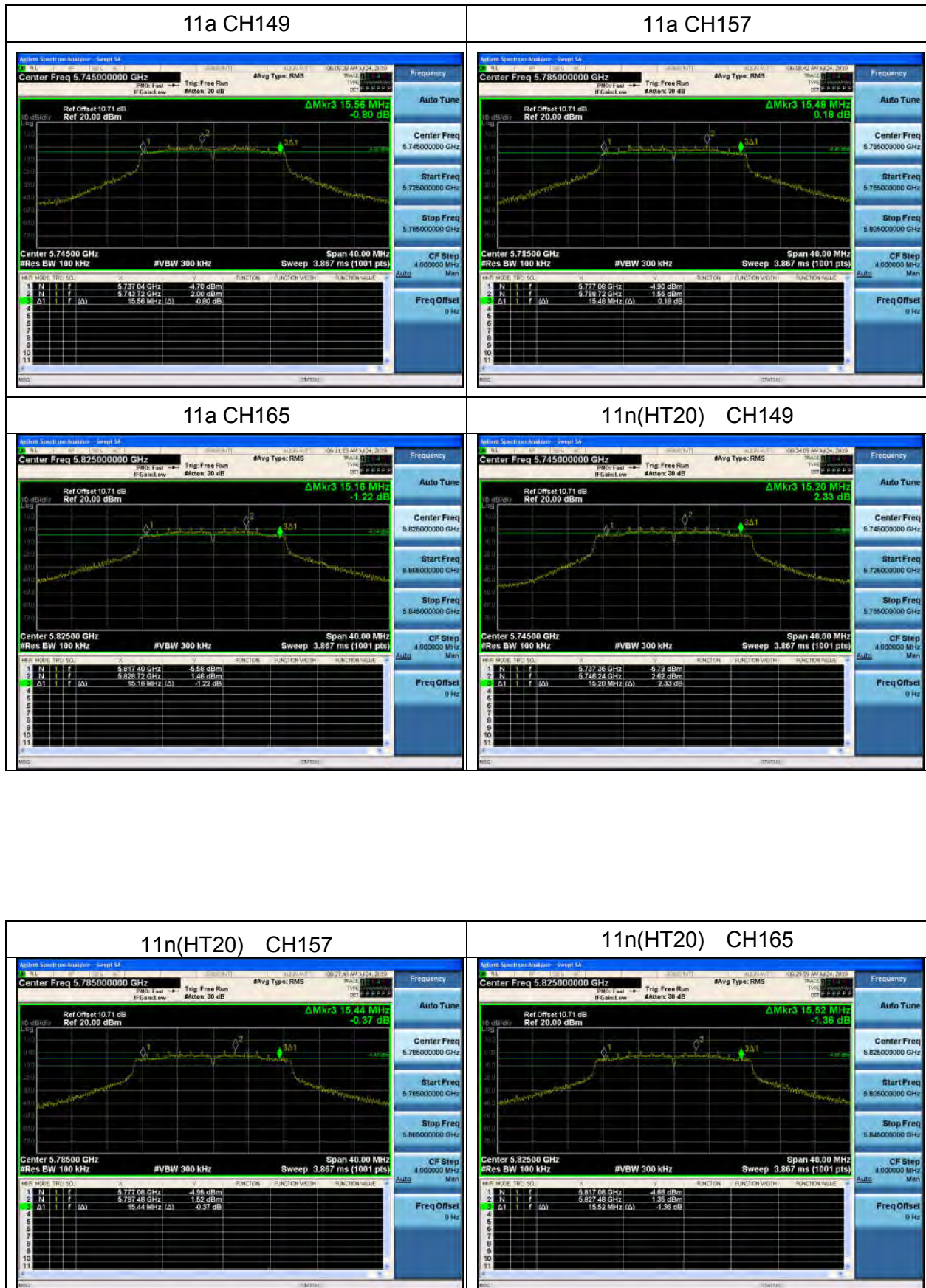

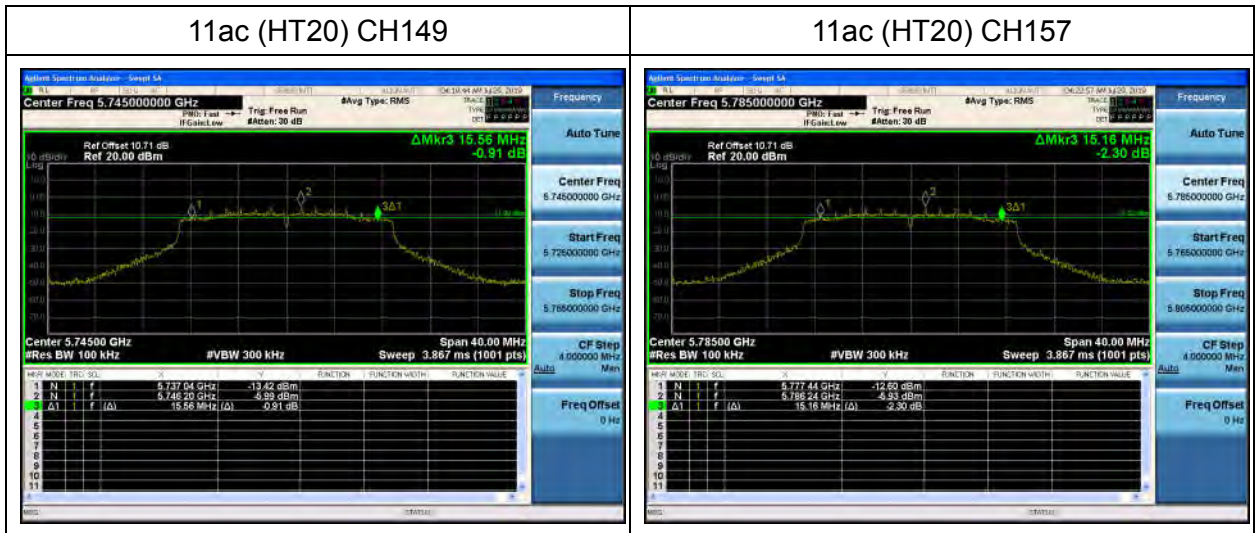
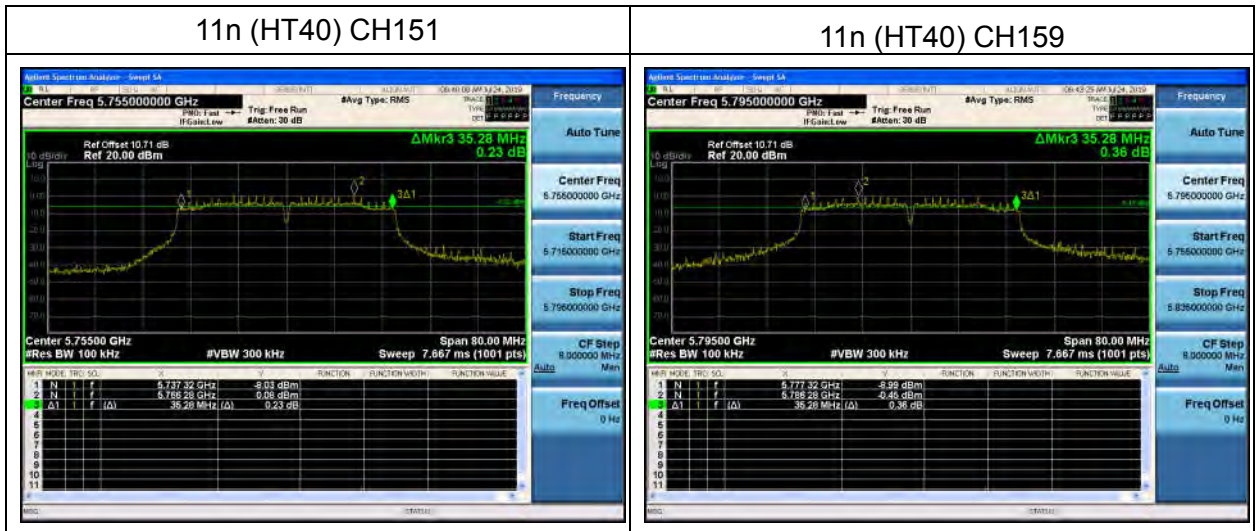

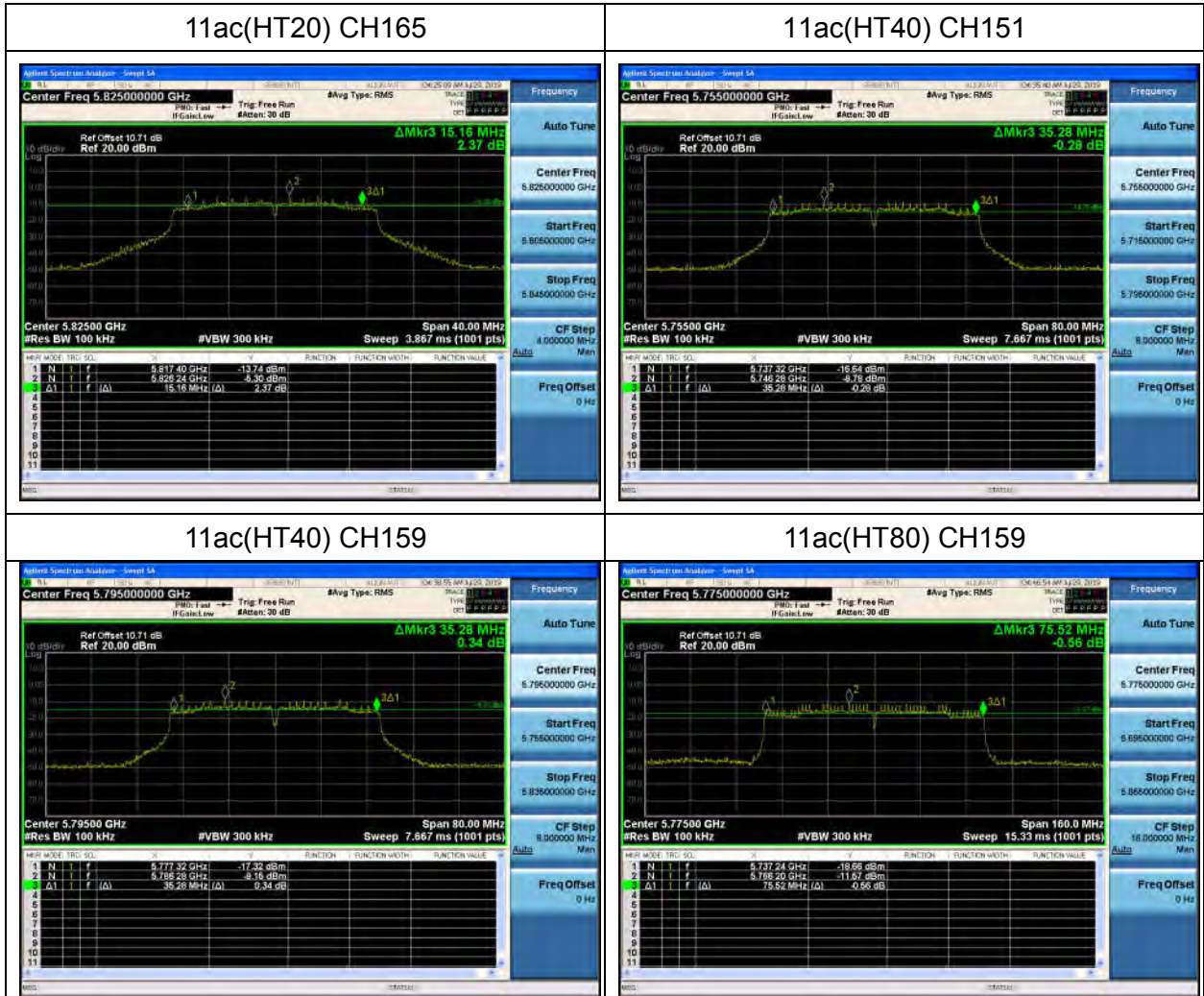



5.6 Radiated spurious emission

Radiated Emission Limits

20dBc in any 100 kHz bandwidth outside the operating frequency band. In case the emission fall within the restricted band specified on 15.205(a), then the 15.209(a) limit in the table below has to be followed.

Frequencies (MHz)	Field Strength (microvolts/meter)	Measurement Distance (meters)
0.009~0.490	2400/F(KHz)	300
0.490~1.705	24000/F(KHz)	30
1.705~30.0	30	30
30~88	100	3
88~216	150	3
216~960	200	3
Above 960	500	3

Spectrum Parameter	Setting
Attenuation	Auto
Start Frequency	1000 MHz
Stop Frequency	10th carrier harmonic
RBW / VBW (emission in restricted band)	1 MHz / 1 MHz for Peak, 1 MHz / 10Hz for Average

Receiver Parameter	Setting
Attenuation	Auto
Start ~ Stop Frequency	9kHz~150kHz / RB 200Hz for QP
Start ~ Stop Frequency	150kHz~30MHz / RB 9kHz for QP
Start ~ Stop Frequency	30MHz~1000MHz / RB 120kHz for QP

5.6.1 Test procedure

The measuring distance of at 3 m shall be used for measurements at frequency up to 1GHz. For frequencies above 1GHz, any suitable measuring distance may be used.

The EUT was placed on the top of a rotating table 0.8 meters above the ground at a 3 meter open area test site. The table was rotated 360 degrees to determine the position of the highest radiation.

The height of the equipment or of the substitution antenna shall be 0.8 m; the height of the test antenna shall vary between 1 m to 4 m. Both horizontal and vertical polarizations of the antenna are set to make the measurement.

For emission measurements above 1 GHz, the EUT shall be placed at a height of 1.5 m above the floor on a support that is RF transparent for the frequencies of interest. Final measurements for the EUT require a measurement antenna height scan of 1 m to 4 m.

The initial step in collecting conducted emission data is a spectrum analyzer peak detector mode pre-scanning the measurement frequency range. Significant peaks are then marked and then Quasi Peak detector mode re-measured.

If the Peak Mode measured value compliance with and lower than Quasi Peak Mode Limit, the EUT shall be deemed to meet QP Limits and then no additional QP Mode measurement performed. For the actual test configuration, please refer to the related Item –EUT Test Photos.

Note: Both horizontal and vertical antenna polarities were tested and performed pretest to three orthogonal axis. The worst case emissions were reported

5.6.2 Test setup

(A) Radiated Emission test-up Frequency Below 30MHz

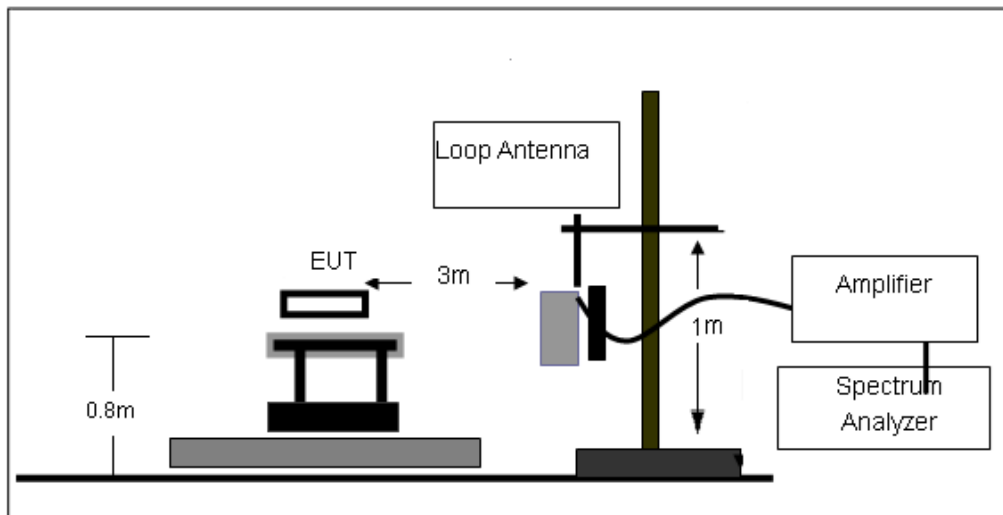

(B) Radiated Emission Test-Up Frequency 30MHz~1GHz

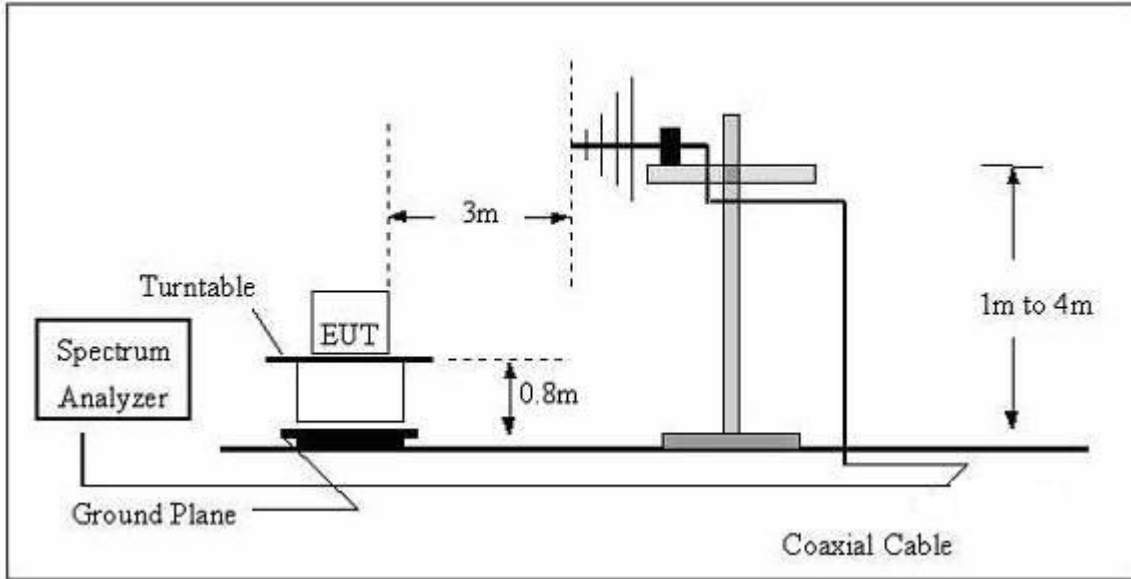

(C) Radiated Emission Test-Setup Frequency Above 1GHz

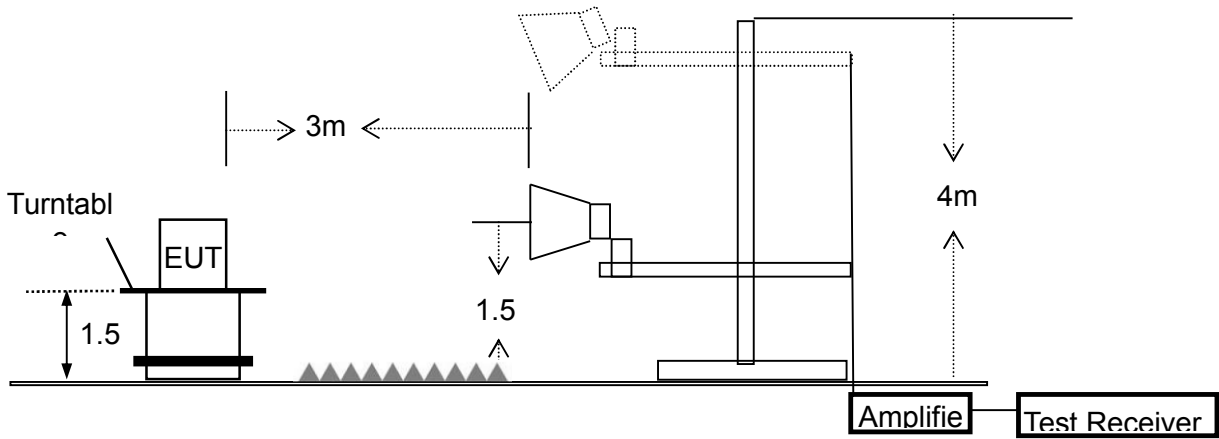

5.6.3 Test results

EUT :	Notebook	Model Name. :	CW1510
Pressure:	1010 hPa	Test Voltage:	DC 12V from adapter AC 120V/60Hz
Test Mode:	TX	Polarization :	--

Below 30MHz

Freq.	Reading	Limit	Margin	State
(MHz)	(dBuV/m)	(dBuV/m)	(dB)	P/F
--	--	--	--	Pass
--	--	--	--	Pass

Note1: The amplitude of spurious emissions which are attenuated by more than 20dB below the permissible value has no need to be reported.

Note2: Distance extrapolation factor = $40 \log(\text{specific distance}/\text{test distance})$ (dB); Limit line = specific limits (dBuV) + distance extrapolation factor.

Between 30MHz – 1GHz

Note1 : Emission Level = Meter Reading + Factor, Margin= Emission Level- Limit, Factor = Antenna Factor + Cable Loss – Pre-amplifier.

Note2 : The peak value is less than the AV value, AV value is not required Factor added by measurement software automatically.

EUT:	Notebook	Model Name. :	CWI510
Pressure:	1010 hPa	Phase:	H
Test Voltage:	DC 12V from adapter AC 120V/60Hz	Mode:	TX+Charging



No.	Mk.	Freq.	Reading Level	Correct Factor	Measurement	Limit	Over	
		MHz	dBuV	dBuV/m	dBuV/m	dBuV/m	dB	Detector
1		42.8997	35.74	-12.99	22.75	40.00	-17.25	QP
2		148.4410	51.31	-16.54	34.77	43.50	-8.73	QP
3		222.9500	47.66	-12.90	34.76	46.00	-11.24	QP
4		301.4223	44.54	-10.82	33.72	46.00	-12.28	QP
5	*	446.4141	48.35	-9.04	39.31	46.00	-6.69	QP
6		744.8659	42.70	-4.83	37.87	46.00	-8.13	QP

EUT:	Notebook	Model Name. :	CWI510
Pressure:	1010 hPa	Phase :	V
Test Voltage:	DC 12V from adapter AC 120V/60Hz	Mode:	TX+Charging

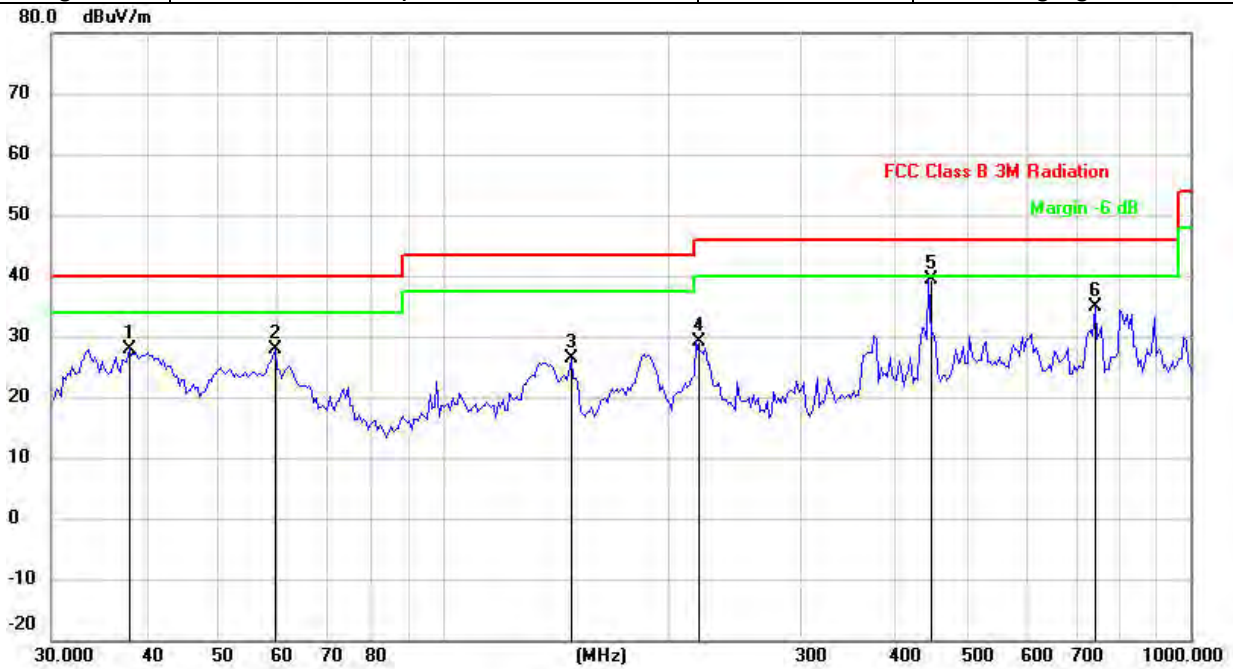

No.	Mk.	Freq.	Reading Level	Correct Factor	Measurement	Limit	Over	
		MHz	dBuV	dBuV/m	dBuV/m	dBuV/m	dB	Detector
1		38.0782	41.71	-13.90	27.81	40.00	-12.19	QP
2		59.6492	41.99	-14.13	27.86	40.00	-12.14	QP
3		148.4410	42.90	-16.54	26.36	43.50	-17.14	QP
4		218.3085	41.95	-12.93	29.02	46.00	-16.98	QP
5	*	446.4141	48.46	-9.04	39.42	46.00	-6.58	QP
6		744.8659	39.77	-4.83	34.94	46.00	-11.06	QP

1G-40GHz

Note1 : Emission Level = Meter Reading + Factor, Margin= Emission Level- Limit, Factor = Antenna Factor + Cable Loss – Pre-amplifier.

Note2 : The peak value is less than the AV value, AV value is not required Factor added by measurement software automatically.

Note3 : The spurious emission of 25GHz – 40GHz band which the margin is lower more than 20dB, So that it is not reported in this test report.

Note4 : The antenna A and antenna B have been tested. The report only shows the worst antenna. The worst case is ANT A.

ANT A
For U-NII-1

Polar	Frequency	Meter Reading	Cable loss	Antenna Factor	Preamp Factor	Emission Level	Limits	Margin	Detector Type
(H/V)	(MHz)	(dBuV)	(dB)	dB/m	(dB)	(dBuV/m)	(dBuV/m)	(dB)	
Low Channel (5185 MHz)-Above 1G									
Vertical	4434.205	54.65	5.94	35.40	44.00	51.99	74.00	-22.01	Pk
Vertical	4434.205	44.15	5.94	35.40	44.00	41.49	54.00	-12.51	AV
Vertical	10370.169	63.47	8.46	39.75	44.50	67.18	74.00	-6.82	Pk
Vertical	10370.169	44.34	8.46	39.75	44.50	48.05	54.00	-5.95	AV
Vertical	15540.124	56.48	10.12	38.80	44.10	61.30	74.00	-12.70	Pk
Vertical	15540.124	43.81	10.12	38.80	42.70	50.03	54.00	-3.97	AV
Horizontal	4434.249	57.93	5.94	35.18	44.00	55.05	74.00	-18.95	Pk
Horizontal	4434.249	43.33	5.94	35.18	44.00	40.45	54.00	-13.55	AV
Horizontal	10370.126	61.06	8.46	38.71	44.50	63.73	74.00	-10.27	Pk
Horizontal	10730.126	46.07	8.46	38.71	44.50	48.74	54.00	-5.26	AV
Horizontal	15540.103	57.88	10.12	38.38	44.10	62.28	74.00	-11.72	Pk
Horizontal	15540.103	43.24	10.12	38.38	44.10	47.64	54.00	-6.36	AV
middle Channel (5200 MHz)-Above 1G									
Vertical	4592.154	57.47	6.48	36.35	44.05	56.25	74.00	-17.75	Pk
Vertical	4592.154	41.59	6.48	36.35	44.05	40.37	54.00	-13.63	AV
Vertical	10401.223	60.62	8.47	37.88	44.51	62.46	74.00	-11.54	Pk
Vertical	10401.223	45.75	8.47	37.88	44.51	47.59	54.00	-6.41	AV
Vertical	15600.182	58.19	10.12	38.8	44.10	63.01	74.00	-10.99	Pk
Vertical	15600.182	41.66	10.12	38.8	42.70	47.88	54.00	-6.12	AV
Horizontal	4592.315	58.66	6.48	36.37	44.05	57.46	74.00	-16.54	Pk
Horizontal	4592.315	42.92	6.48	36.37	44.05	41.72	54.00	-12.28	AV
Horizontal	10400.206	61.95	8.47	38.64	44.50	64.56	74.00	-9.44	Pk
Horizontal	10400.206	46.71	8.47	38.64	44.50	49.32	54.00	-4.68	AV
Horizontal	15600.179	57.87	10.12	38.38	44.10	62.27	74.00	-11.73	Pk
Horizontal	15600.179	43.95	10.12	38.38	44.10	48.35	54.00	-5.65	AV
High Channel (5240 MHz)-Above 1G									
Vertical	4739.216	59.71	7.10	37.24	43.50	60.55	74.00	-13.45	Pk
Vertical	4739.216	45.72	7.10	37.24	43.50	46.56	54.00	-7.44	AV

Vertical	10480.274	62.08	8.46	37.68	44.50	63.72	74.00	-10.28	Pk
Vertical	10480.274	47.09	8.46	37.68	44.50	48.73	54.00	-5.27	AV
Vertical	15720.189	57.10	10.12	38.8	44.10	61.92	74.00	-12.08	Pk
Vertical	15720.189	43.69	10.12	38.8	42.70	49.91	54.00	-4.09	AV
Horizontal	4739.116	59.15	7.10	37.24	43.50	59.99	74.00	-14.01	Pk
Horizontal	4739.116	44.81	7.10	37.24	43.50	45.65	54.00	-8.35	AV
Horizontal	10481.402	59.83	8.46	38.57	44.50	62.36	74.00	-11.64	Pk
Horizontal	10481.402	42.52	8.46	38.57	44.50	45.05	54.00	-8.95	AV
Horizontal	15720.263	57.26	10.12	38.38	44.10	61.66	74.00	-12.34	Pk
Horizontal	15720.263	42.58	10.12	38.38	44.10	46.98	54.00	-7.02	AV

Note: Both horizontal and vertical antenna polarities were tested and only the worst case(horizontal) emissions were reported.

For U-NII-3

Polar	Frequency	Meter Reading	Cable loss	Antenna Factor	Preamp Factor	Emission Level	Limits	Margin	Detector Type
(H/V)	(MHz)	(dBuV)	(dB)	dB/m	(dB)	(dBuV/m)	(dBuV/m)	(dB)	
Low Channel (5745 MHz)-Above 1G									
Vertical	4679.136	58.94	5.94	35.40	44.00	56.28	74.00	-17.72	Pk
Vertical	4679.136	45.49	5.94	35.40	44.00	42.83	54.00	-11.17	AV
Vertical	11490.052	60.66	8.46	39.75	44.50	64.37	74.00	-9.63	Pk
Vertical	11490.052	45.60	8.46	39.75	44.50	49.31	54.00	-4.69	AV
Vertical	17235.261	58.17	10.12	38.80	44.10	62.99	74.00	-11.01	Pk
Vertical	17235.261	40.77	10.12	38.80	42.70	46.99	54.00	-7.01	AV
Horizontal	4679.135	58.88	5.94	35.18	44.00	56.00	74.00	-18.00	Pk
Horizontal	4679.135	44.74	5.94	35.18	44.00	41.86	54.00	-12.14	AV
Horizontal	11490.302	60.80	8.46	38.71	44.50	63.47	74.00	-10.53	Pk
Horizontal	11490.302	44.97	8.46	38.71	44.50	47.64	54.00	-6.36	AV
Horizontal	17235.246	60.71	10.12	38.38	44.10	65.11	74.00	-8.89	Pk
Horizontal	17235.246	44.36	10.12	38.38	44.10	48.76	54.00	-5.24	AV
middle Channel (5785 MHz)-Above 1G									
Vertical	4592.208	59.42	6.48	36.35	44.05	58.20	74.00	-15.80	Pk
Vertical	4592.208	44.86	6.48	36.35	44.05	43.64	54.00	-10.36	AV
Vertical	11570.136	61.53	8.47	37.88	44.51	63.37	74.00	-10.63	Pk
Vertical	11570.136	43.80	8.47	37.88	44.51	45.64	54.00	-8.36	AV
Vertical	17355.249	57.56	10.12	38.8	44.10	62.38	74.00	-11.62	Pk
Vertical	17355.249	41.65	10.12	38.8	42.70	47.87	54.00	-6.13	AV
Horizontal	4592.138	60.02	6.48	36.37	44.05	58.82	74.00	-15.18	Pk
Horizontal	4592.138	44.36	6.48	36.37	44.05	43.16	54.00	-10.84	AV
Horizontal	11570.256	61.91	8.47	38.64	44.50	64.52	74.00	-9.48	Pk
Horizontal	11570.256	47.77	8.47	38.64	44.50	50.38	54.00	-3.62	AV
Horizontal	17355.127	60.66	10.12	38.38	44.10	65.06	74.00	-8.94	Pk
Horizontal	17355.127	46.07	10.12	38.38	44.10	50.47	54.00	-3.53	AV
High Channel (5825 MHz)-Above 1G									
Vertical	5039.156	61.36	7.10	37.24	43.50	62.20	74.00	-11.80	Pk
Vertical	5039.156	46.48	7.10	37.24	43.50	47.32	54.00	-6.68	AV
Vertical	11650.131	55.86	8.46	37.68	44.50	57.50	74.00	-16.50	Pk
Vertical	11650.131	44.17	8.46	37.68	44.50	45.81	54.00	-8.19	AV
Vertical	17475.289	60.91	10.12	38.8	44.10	65.73	74.00	-8.27	Pk
Vertical	17475.289	40.73	10.12	38.8	42.70	46.95	54.00	-7.05	AV
Horizontal	5039.316	67.28	7.10	37.24	43.50	68.12	74.00	-5.88	Pk
Horizontal	5039.316	42.39	7.10	37.24	43.50	43.23	54.00	-10.77	AV



Horizontal	11650.203	57.20	8.46	38.57	44.50	59.73	74.00	-14.27	Pk
Horizontal	11650.203	43.95	8.46	38.57	44.50	46.48	54.00	-7.52	AV
Horizontal	17475.152	61.37	10.12	38.38	44.10	65.77	74.00	-8.23	Pk
Horizontal	17475.152	44.51	10.12	38.38	44.10	48.91	54.00	-5.09	AV

5.7 Conduction spurious emission

5.7.1 Limits

Undesirable emission limits. Except as shown in paragraph (b)(7) of this section, the maximum emissions outside of the frequency bands of operation shall be attenuated in accordance with the following limits:

Frequency Band (MHz)	Limit
5150 - 5250	Outside of the 5.15-5.35 GHz band: e.i.r.p. -27 dBm
5250 - 5350	Outside of the 5.15-5.35 GHz band: e.i.r.p. -27 dBm
5470 - 5725	Outside of the 5.47-5.725 GHz band: e.i.r.p. -27 dBm
5725 - 5850	All emissions shall be limited to a level of -27 dBm/MHz at 75 MHz or more above or below the band edge increasing linearly to 10 dBm/MHz at 25 MHz above or below the band edge, and from 25 MHz above or below the band edge increasing linearly to a level of 15.6 dBm/MHz at 5 MHz above or below the band edge, and from 5 MHz above or below the band edge increasing linearly to a level of 27 dBm/MHz at the band edge.

5.7.2 Test setup

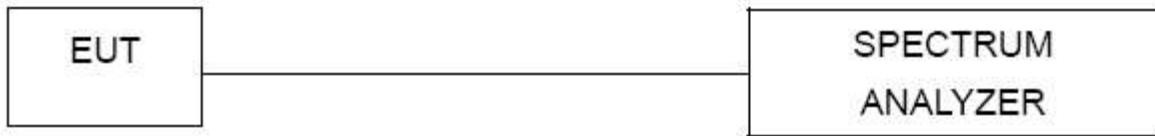

5.7.3 Test procedure

Use the following spectrum analyzer settings:

Span = wide enough to capture the peak level of the in-band emission and all spurious emissions (e.g., harmonics) from the lowest frequency generated in the EUT up through the 10th harmonic. Typically, several plots are required to cover this entire span.

RBW = 1 MHz for $f \geq 1$ GHz, 100 kHz for $f < 1$ GHz

VBW \geq RBW

Sweep = auto

Detector function = peak

Trace = max hold

Allow the trace to stabilize

5.7.4 Test results

Note1: The antenna A and antenna B have been tested. The report only shows the worst antenna. The worst case is ANT A.

ANT A

For U-NII-1

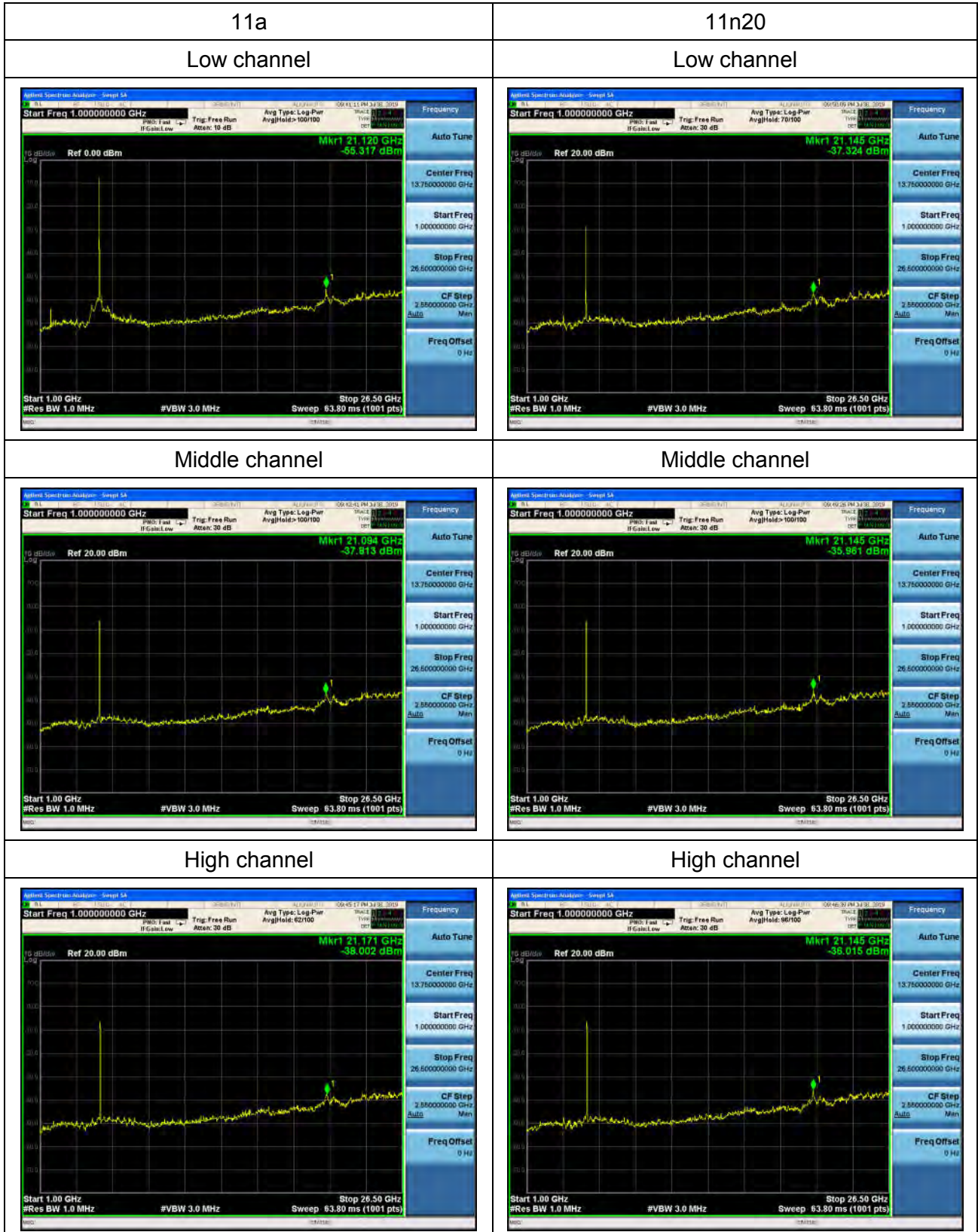

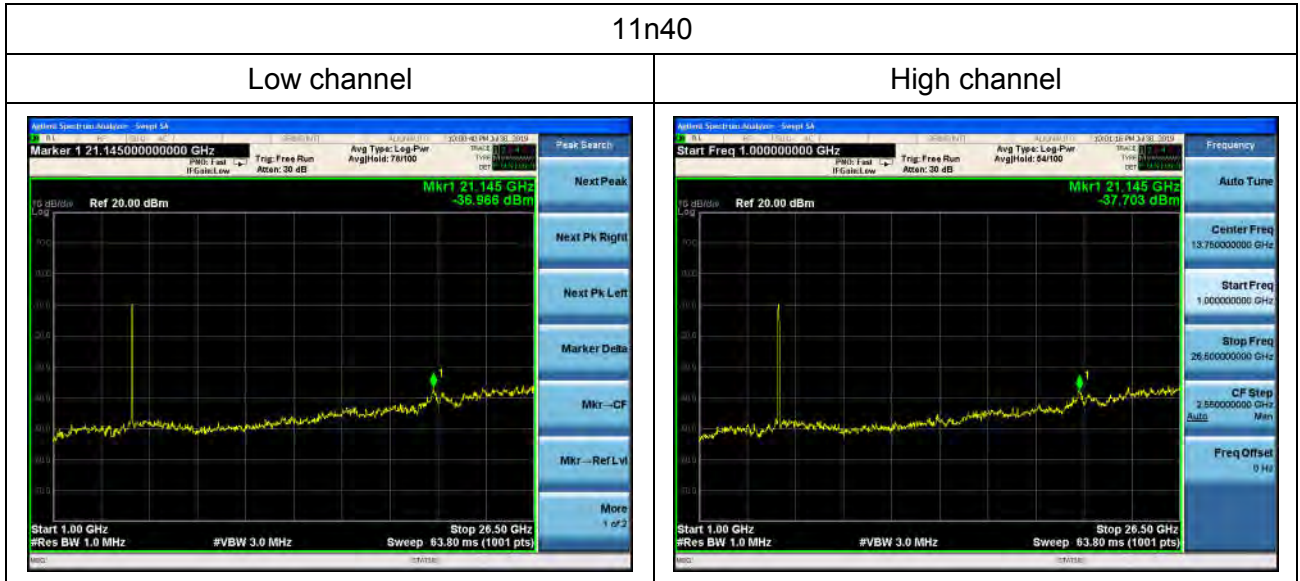

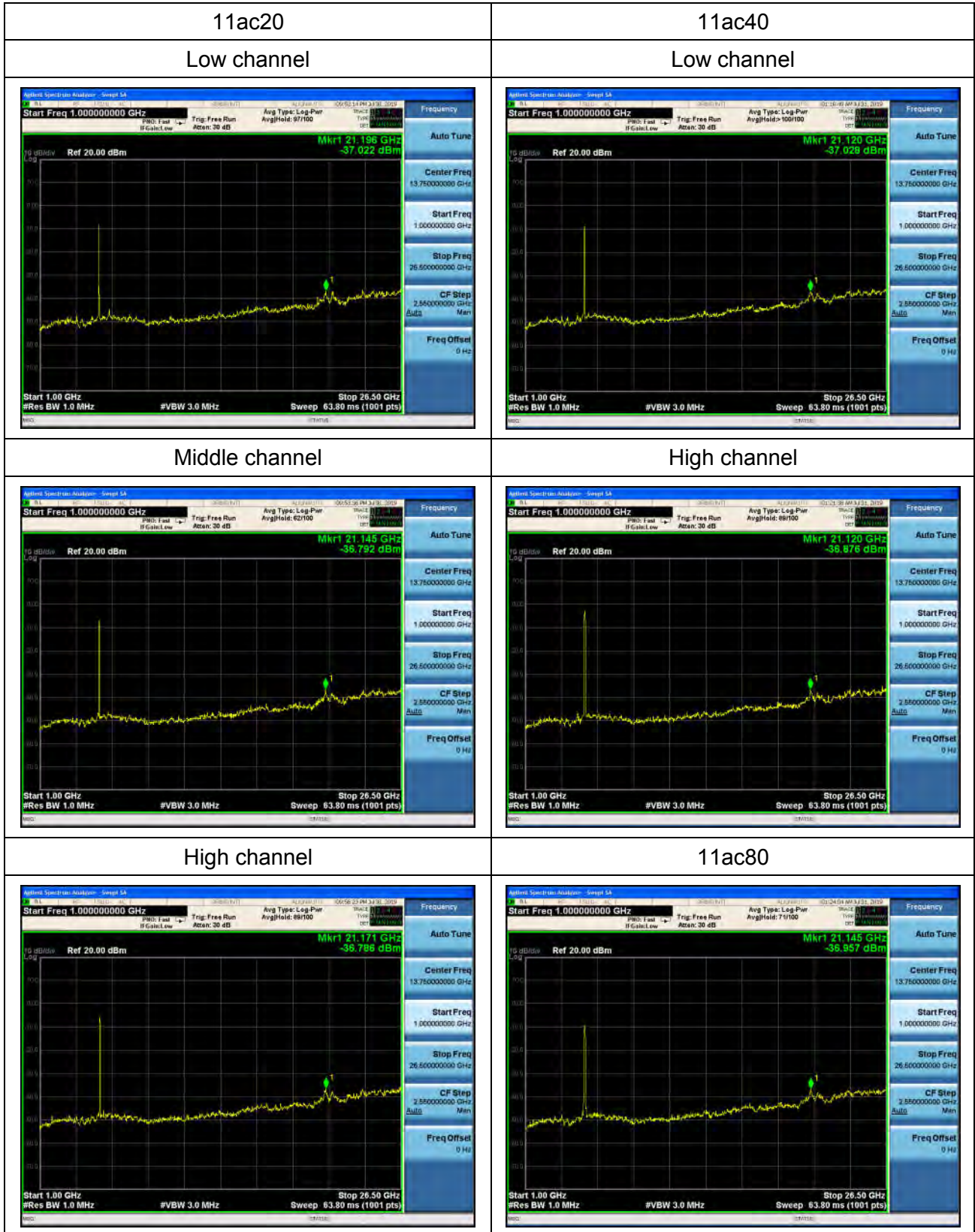

For U-NII-3

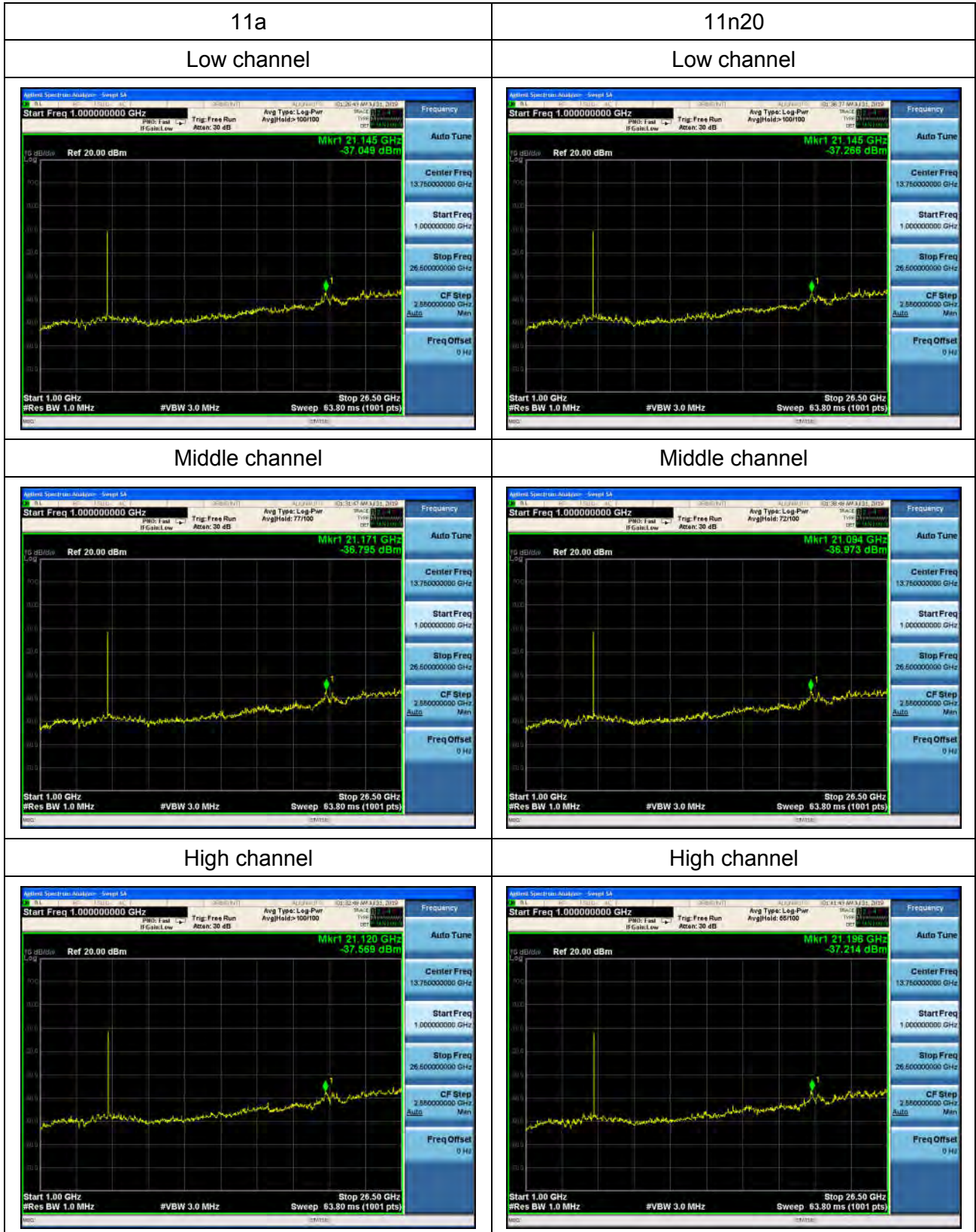

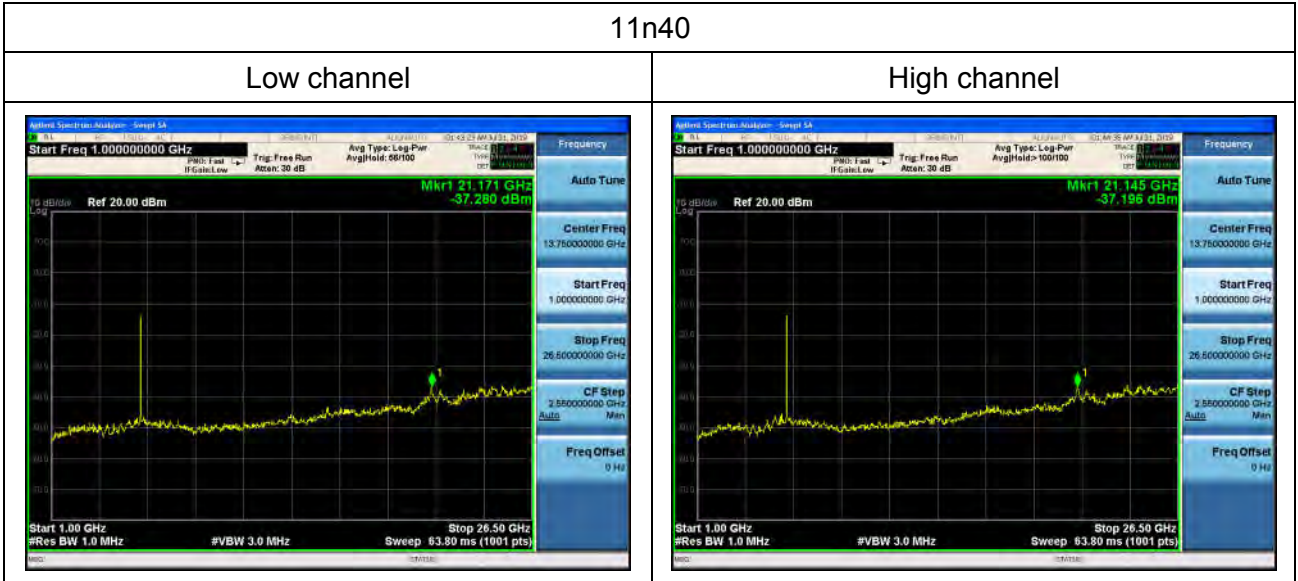

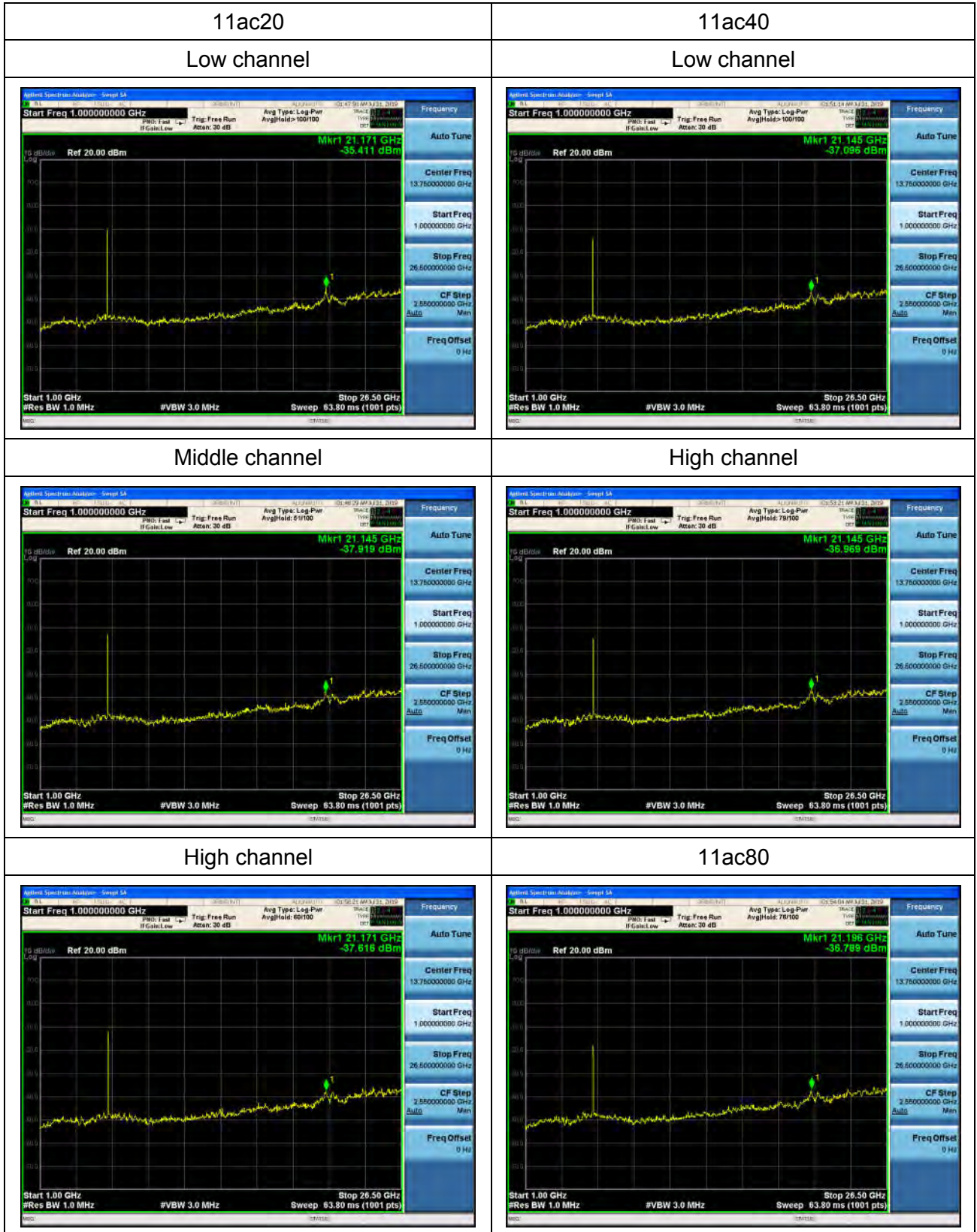

Conduction Band edge For U-NII-1

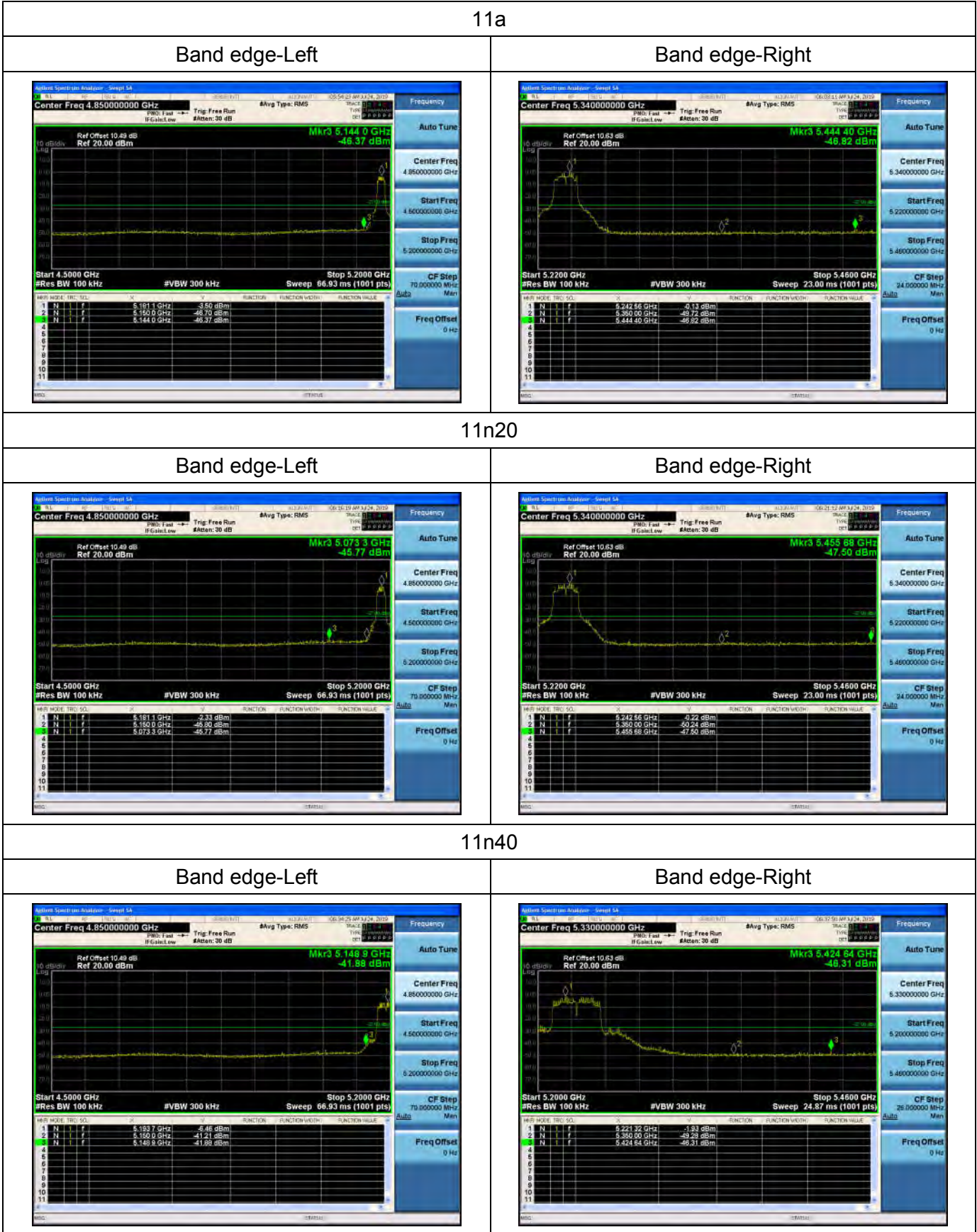

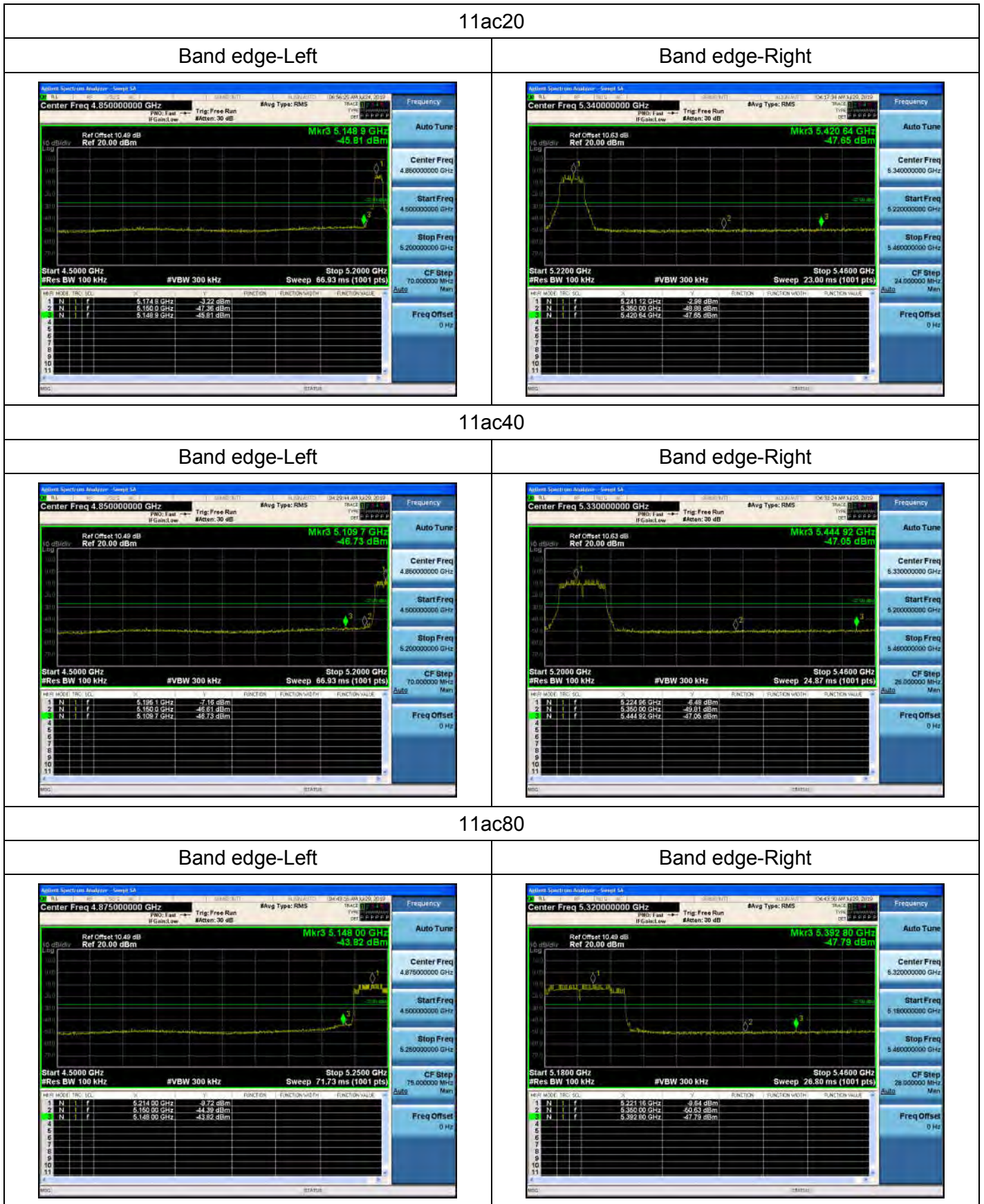

Conduction Band edge For U-NII-3

11a

Band edge-Left



Band edge-Right



11n20

Band edge-Left



Band edge-Right



11n40

Band edge-Left



Band edge-Right



11ac20

Band edge-Left

Band edge-Right



11ac40

Band edge-Left

Band edge-Right



11ac80

Band edge-Left

Band edge-Right



5.8 Power spectral density

5.8.1 Limit

For the band 5.15-5.25 GHz

For client devices in the 5.15-5.25 GHz band, the maximum power spectral density shall not exceed 11 dBm in any 1 megahertz band. If transmitting antennas of directional gain greater than 6 dBi are used, the maximum power spectral density shall be reduced by the amount in dB that the directional gain of the antenna exceeds 6 dBi.

For the band 5.25-5.35 GHz and 5.47-5.725 GHz

The maximum power spectral density shall not exceed 11 dBm in any 1 megahertz band. If transmitting antennas of directional gain greater than 6 dBi are used, the maximum power spectral density shall be reduced by the amount in dB that the directional gain of the antenna exceeds 6 dBi.

For the band 5.725-5.85 GHz

The maximum power spectral density shall not exceed 30 dBm in any 500-kHz band. If transmitting antennas of directional gain greater than 6 dBi are used, the maximum power spectral density shall be reduced by the amount in dB that the directional gain of the antenna exceeds 6 dBi.

5.8.2 Test procedure

For U-NII-1

1. Set analyzer center frequency to NII channel center frequency.
2. Set the RBW \geq 1MHz.
3. Set the VBW \geq 3 x RBW.
4. Detector = peak.
5. Sweep time = auto couple.
6. Trace mode = max hold.
7. Allow trace to fully stabilize.
8. Use the peak marker function to determine the maximum amplitude level.

For U-NII-3

1. Set analyzer center frequency to NII channel center frequency.
2. Set the RBW \geq 510kHz.
3. Set the VBW \geq 3 x RBW.
4. Detector = peak.
5. Sweep time = auto couple.
6. Trace mode = max hold.
7. Allow trace to fully stabilize.
8. Use the peak marker function to determine the maximum amplitude level.

5.8.3 Test setup

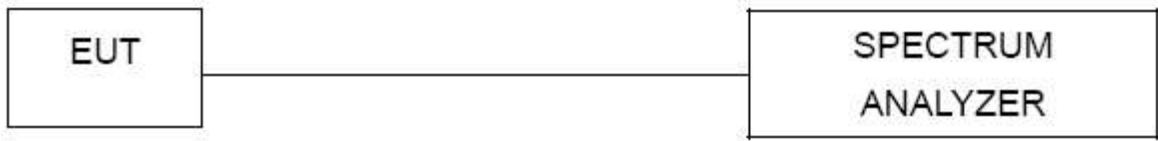

5.8.4 Test results

Note1: For FCC standard, if transmitting antennas of directional gain greater than 6 dBi are used, all band of the maximum power spectral density shall be reduced by the amount in dB that the directional gain of the antenna exceeds 6 dBi.

Note 2: Transmitting antennas of directional gain in Band I(5150 MHz to 5250 MHz) is 6.3 dBi

Formulas: Directional gain = $G_{ANT} + \text{Array Gain}$, Array Gain = $10 \log(N_{ANT}/N_{SS})$ dB, $N_{SS} = 1$, G_{ANT} set

equal to the gain of the antenna having the highest gain.

Note 3: The total PSD method used the sum spectra maxima across the outputs.

For U-NII-1

Mode	Channel	Frequency(MHz)	Measurement PSD (dBm/MHz)		Total PSD of antennas	Limit (dBm/MHz)	Result
			ANTA	ANTB			
11a	CH36	5180	2.014	-0.118	4.09	11	Pass
11a	CH44	5220	5.585	-0.871	6.47	11	Pass
11a	CH48	5240	5.114	-1.517	5.97	11	Pass
11n(HT20)	CH36	5180	2.452	-1.619	3.89	11	Pass
11n(HT20)	CH44	5220	4.556	-1.183	5.58	11	Pass
11n(HT20)	CH48	5240	5.126	-1.686	5.95	11	Pass
11n(HT40)	CH38	5190	-1.396	-3.811	0.57	11	Pass
11n(HT40)	CH46	5230	2.864	-4.459	3.60	11	Pass
11ac(HT20)	CH36	5180	2.530	-2.951	3.61	11	Pass
11ac (HT20)	CH40	5200	1.408	-2.782	2.81	11	Pass
11ac (HT20)	CH48	5240	1.879	-2.382	3.26	11	Pass
11ac (HT40)	CH38	5190	-1.860	-5.103	-0.18	11	Pass
11ac (HT40)	CH46	5230	-1.652	-4.83	0.05	11	Pass
11ac (HT80)	CH46	5230	-4.586	-7.302	-2.72	11	Pass

Test plots

For U-NII-1
ANT A

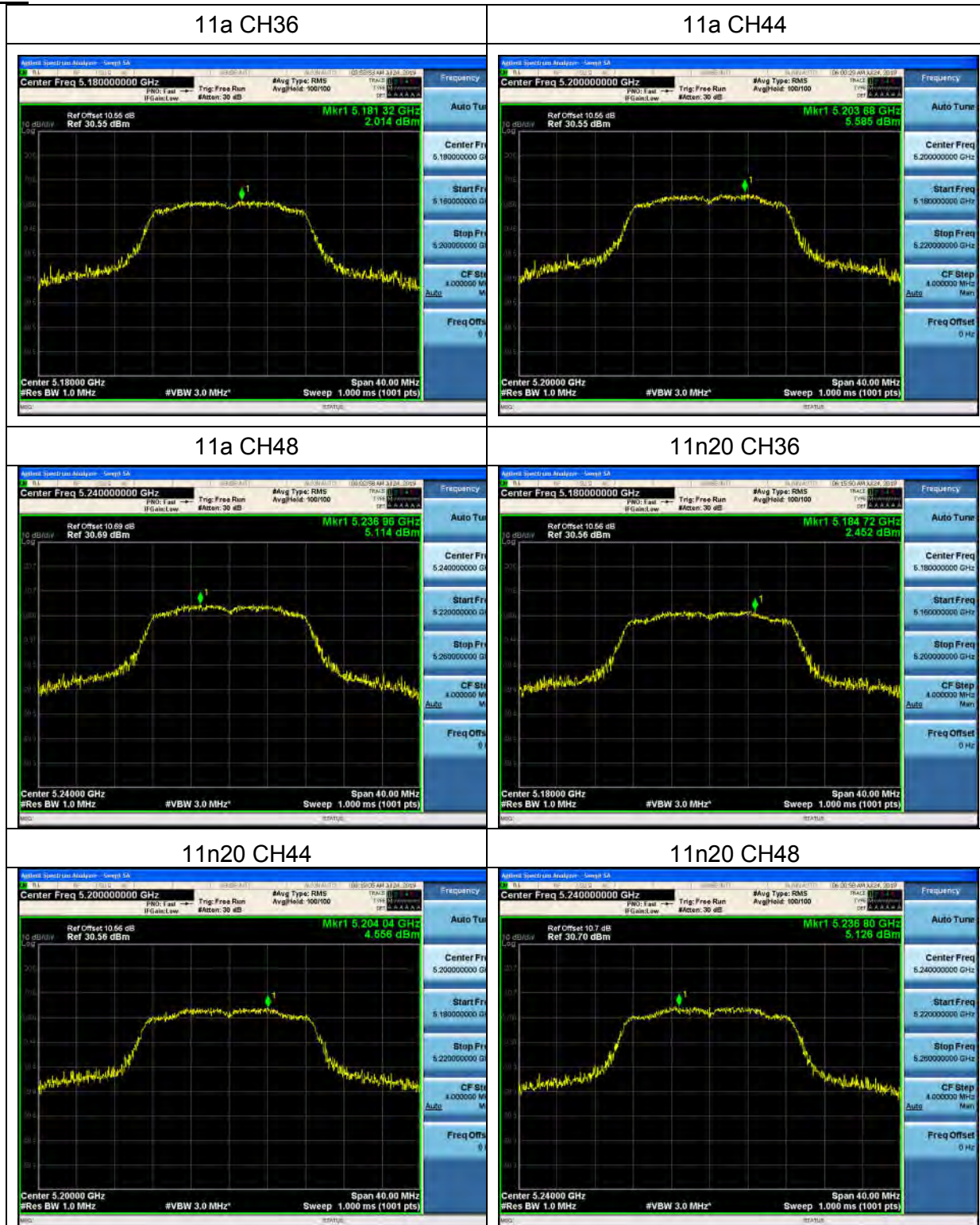

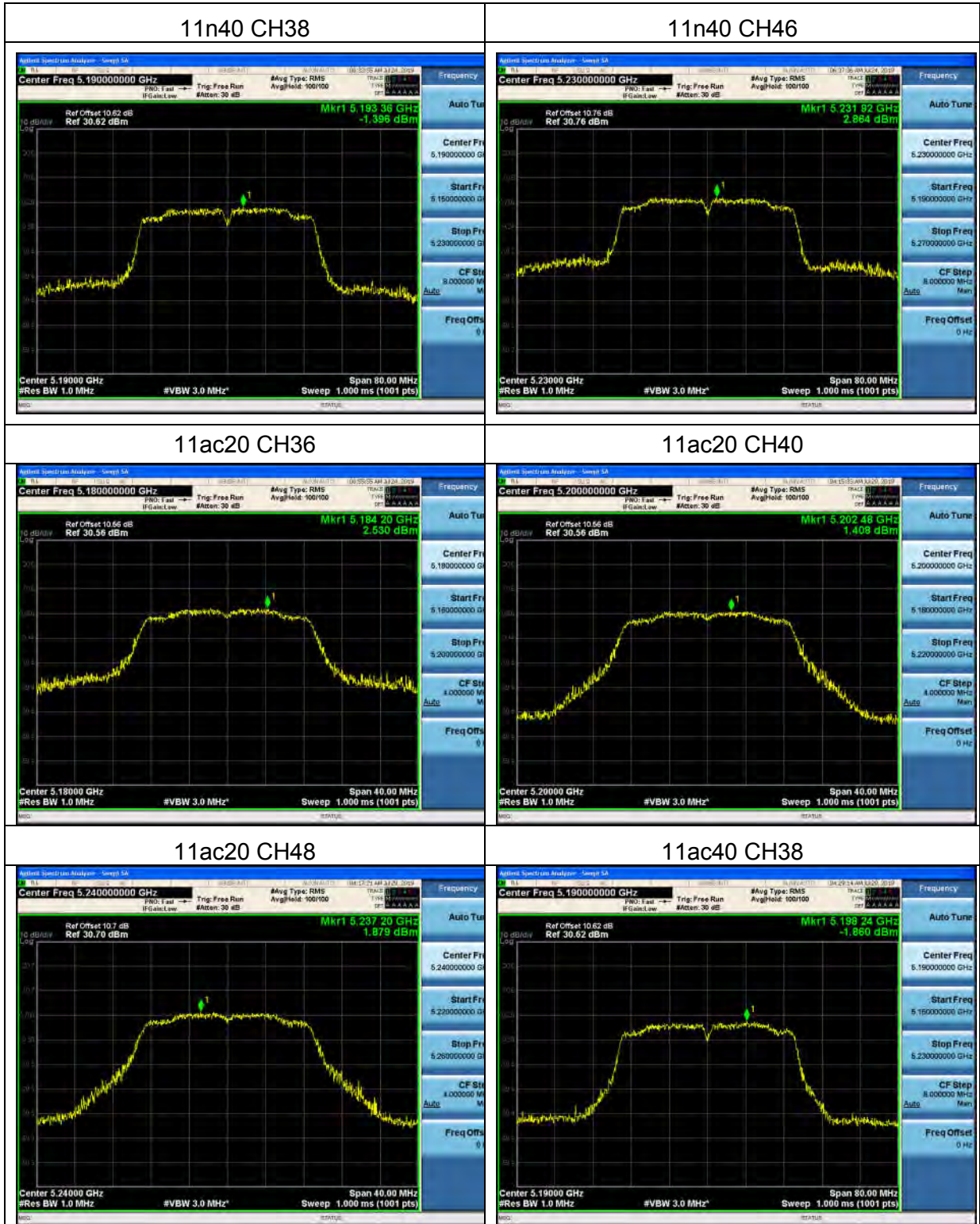

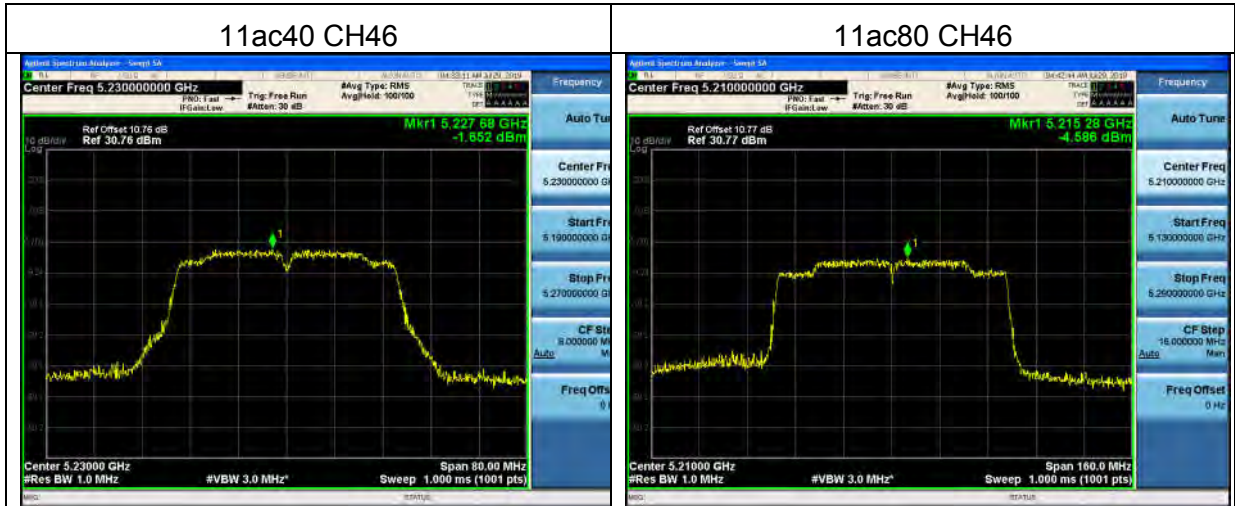

ANT B

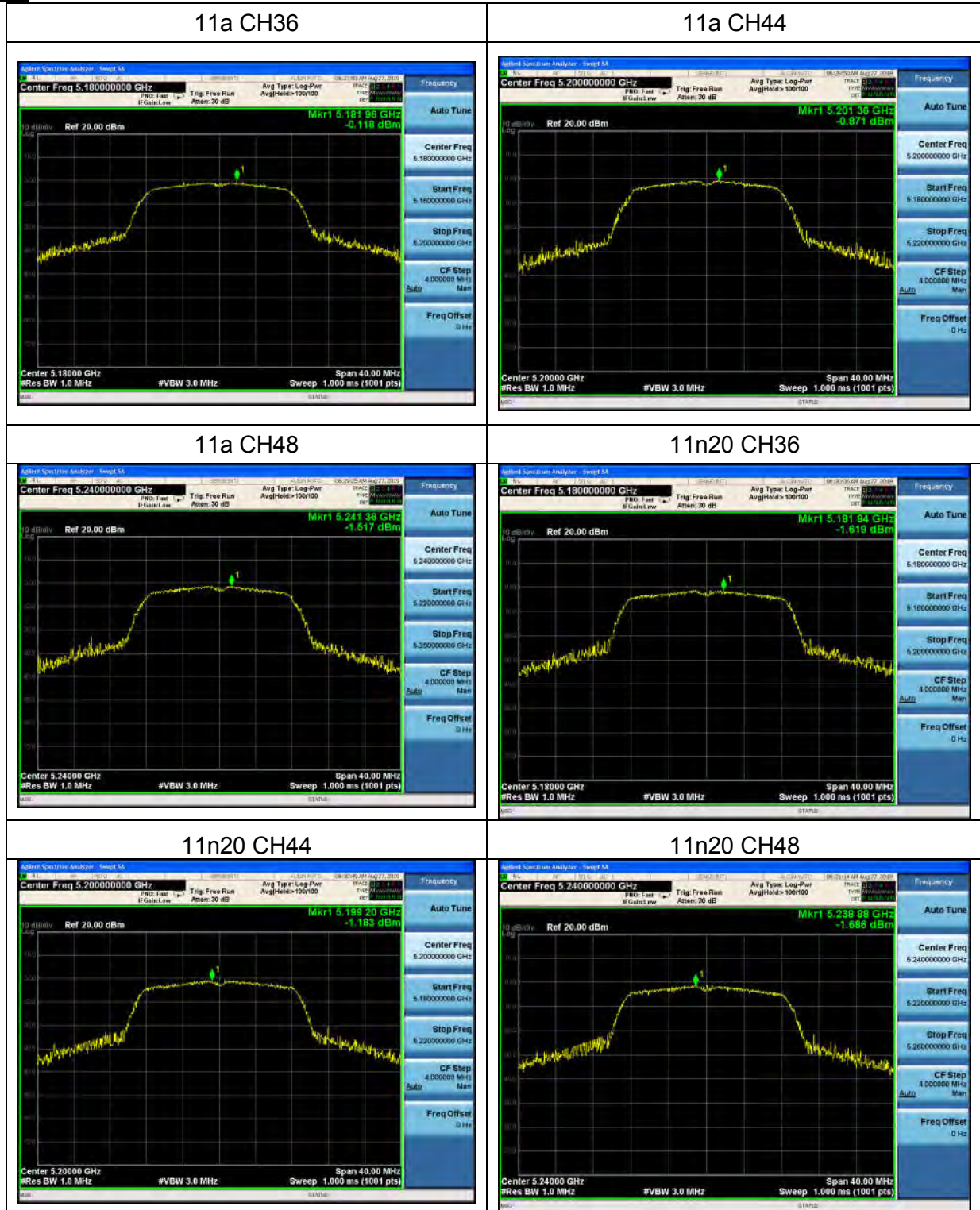

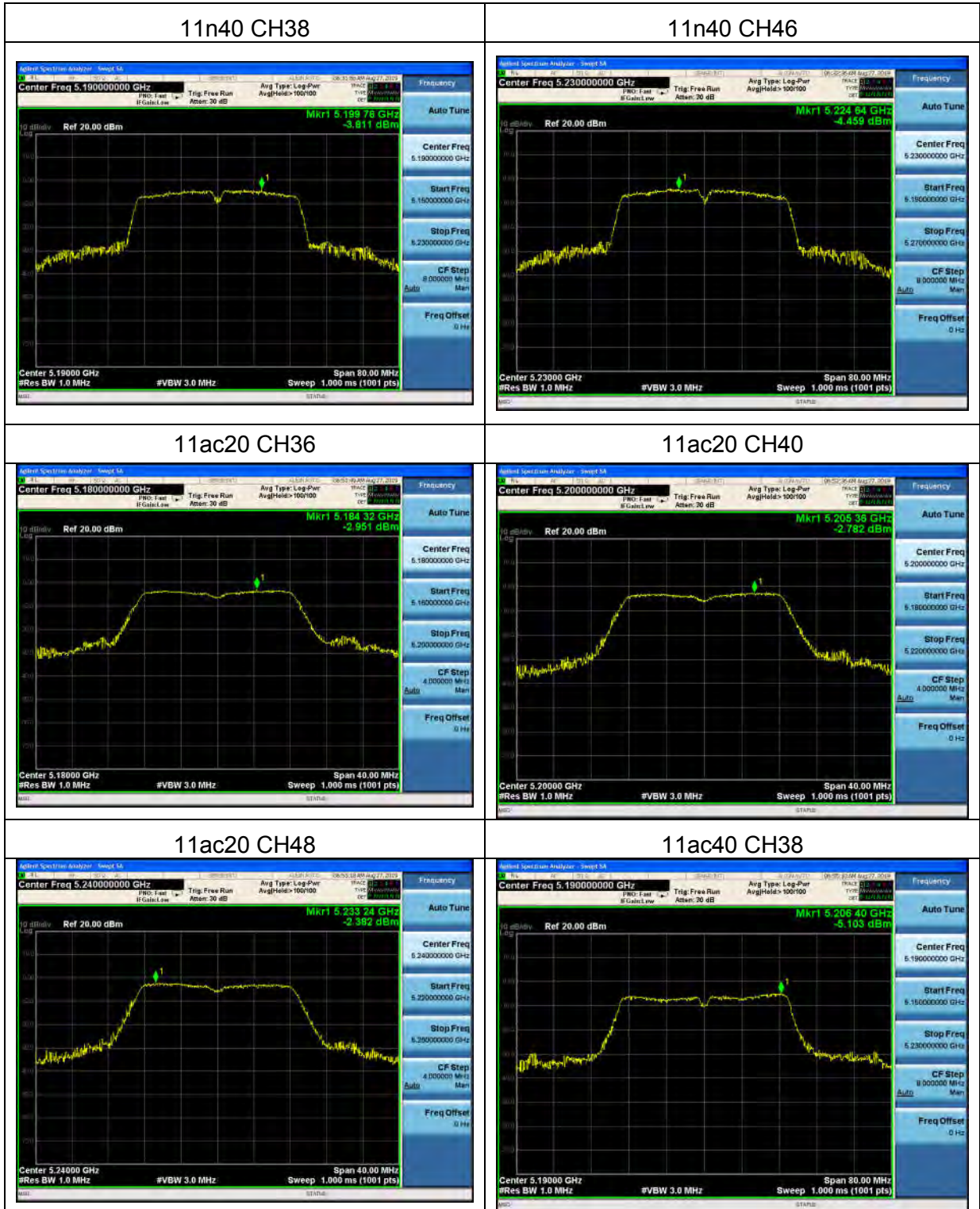

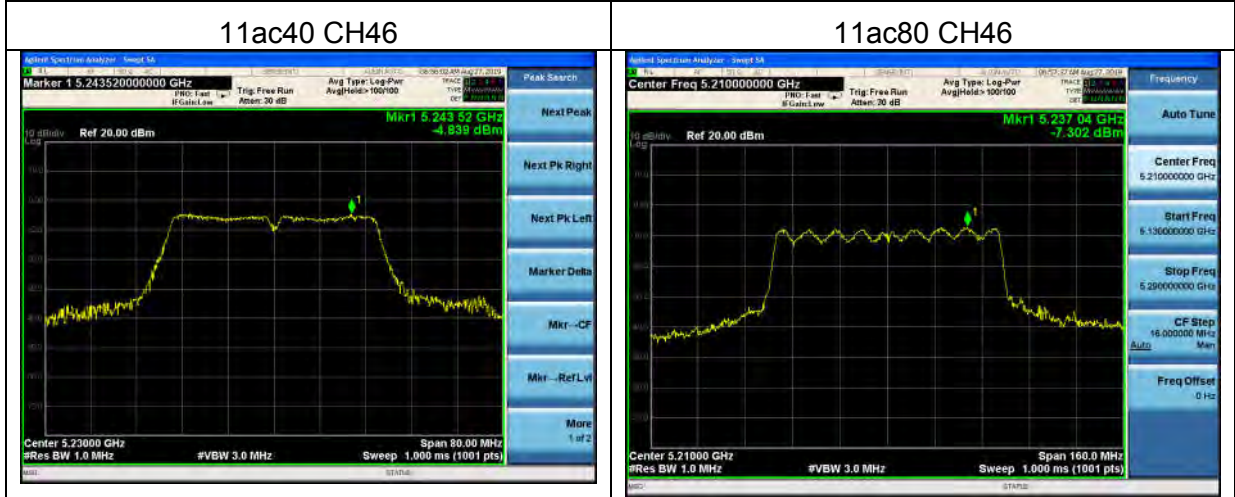

For U-NII-3

Mode	Channel	Frequency (MHz)	PSD (dBm/510kHz)		PSD (dBm/500kHz)		Total PSD of antennas	Limit (dBm/500kHz)	Result
			ANTA	ANTB	ANTA	ANTB			
11a	CH149	5745	-9.336	-5.299	0.114	0.289	-3.85	30	Pass
11a	CH157	5785	-8.977	-5.761	0.124	0.260	-4.07	30	Pass
11a	CH165	5825	-9.543	-6.345	0.109	0.227	-4.65	30	Pass
11n20	CH149	5745	-8.602	-5.111	0.135	0.302	-3.50	30	Pass
11n20	CH157	5785	-9.382	-6.518	0.113	0.219	-4.71	30	Pass
11n20	CH165	5825	-9.661	-6.115	0.106	0.240	-4.53	30	Pass
11n40	CH151	5755	-11.912	-9.008	0.063	0.123	-7.21	30	Pass
11n40	CH159	5795	-13.015	-9.606	0.049	0.107	-7.97	30	Pass
11ac20	CH149	5745	-9.067	-7.116	0.122	0.190	-4.97	30	Pass
11ac20	CH157	5785	-9.565	-7.098	0.108	0.191	-5.15	30	Pass
11ac20	CH165	5825	-9.644	-6.560	0.106	0.216	-4.82	30	Pass
11ac40	CH151	5755	-12.012	-9.292	0.062	0.115	-7.43	30	Pass
11ac40	CH159	5795	-13.015	-9.009	0.049	0.123	-7.56	30	Pass
11ac80	CH159	5795	-14.843	-11.239	0.032	0.074	-9.67	30	Pass

Note: If the measurement is X dBm/510kHz, thus X dBm/510kHz = $(10^{X/10}) * (500 / 510)$ dBm/500kHz

Test plots

For U-NII-3
ANT A

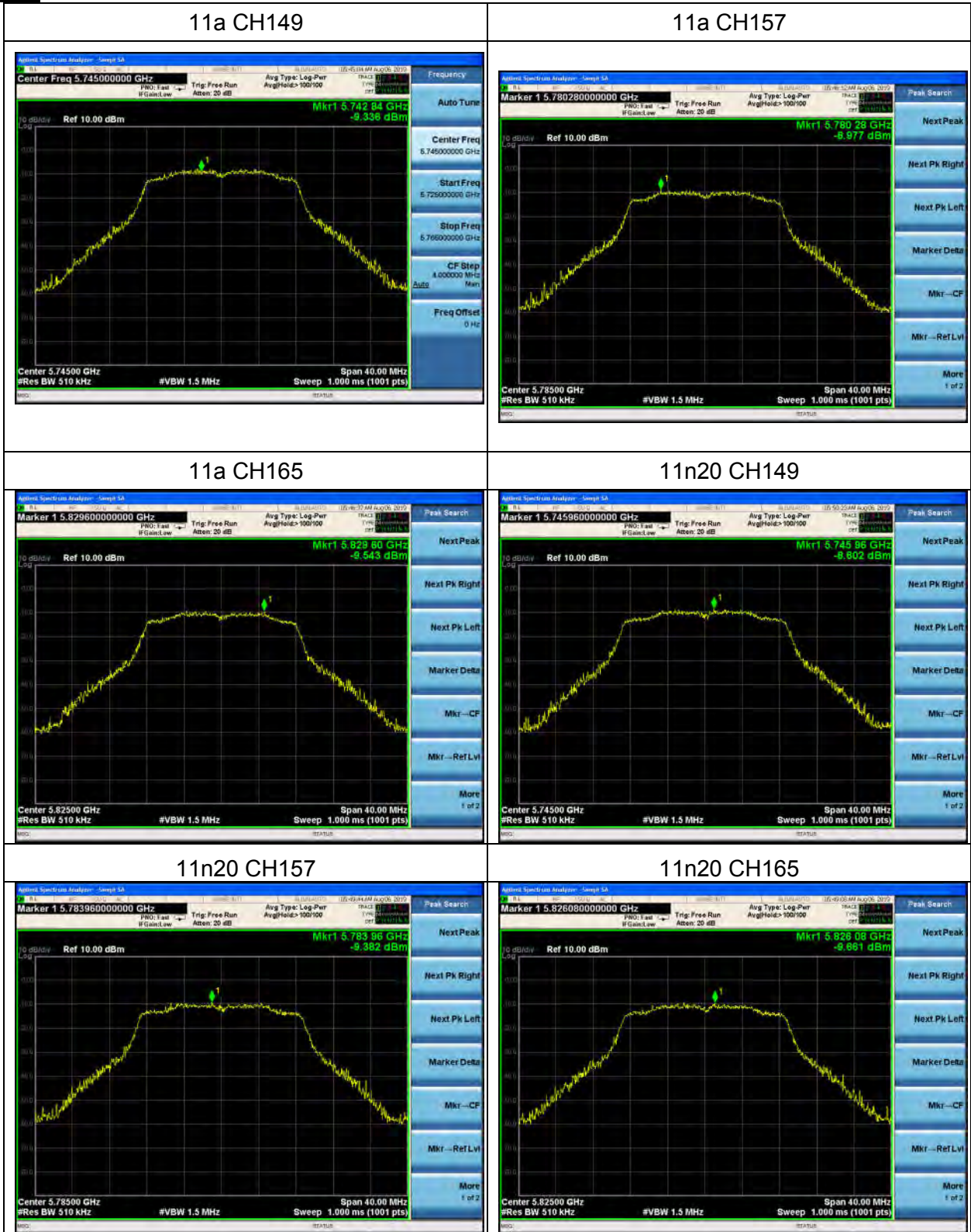

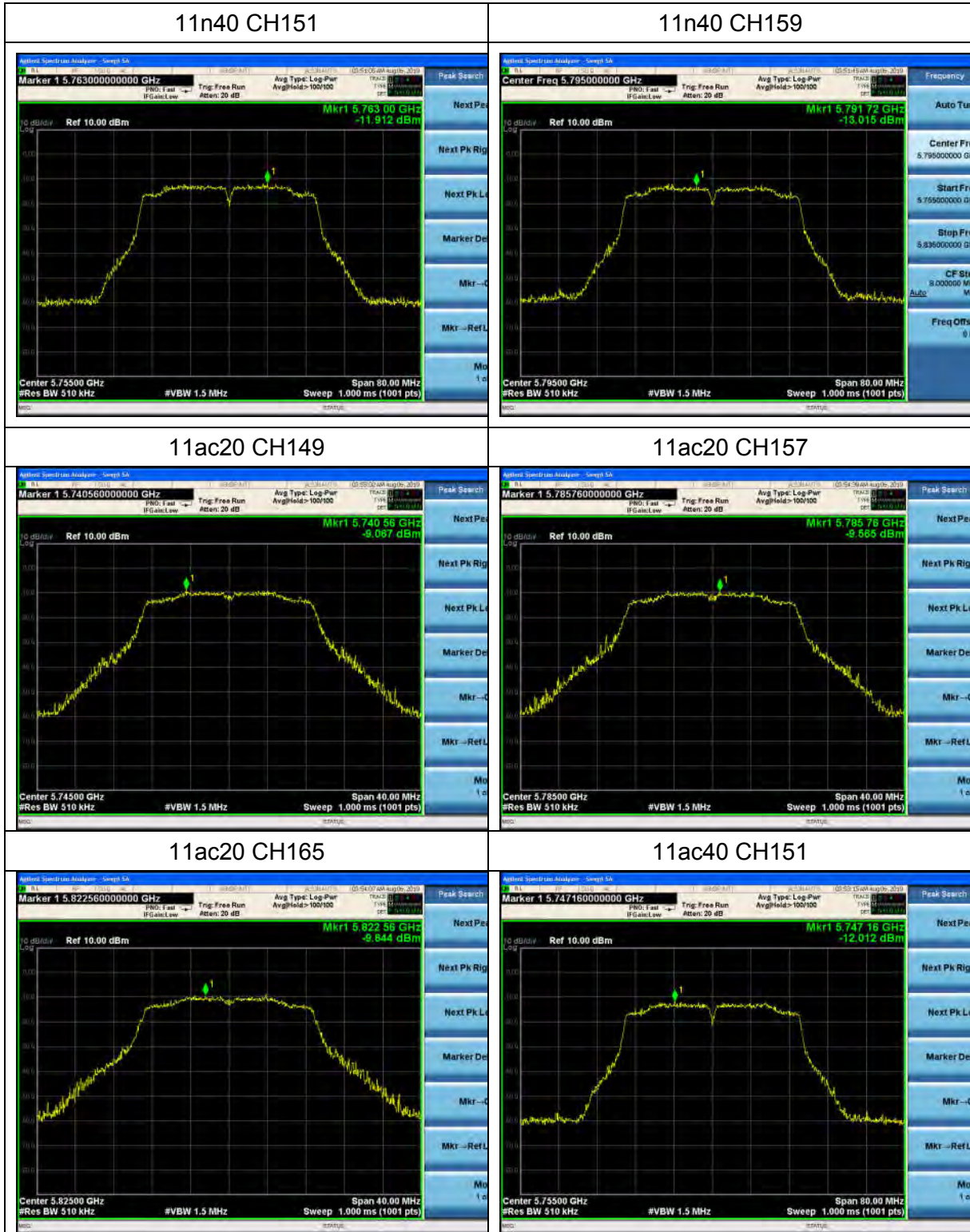



ANT B

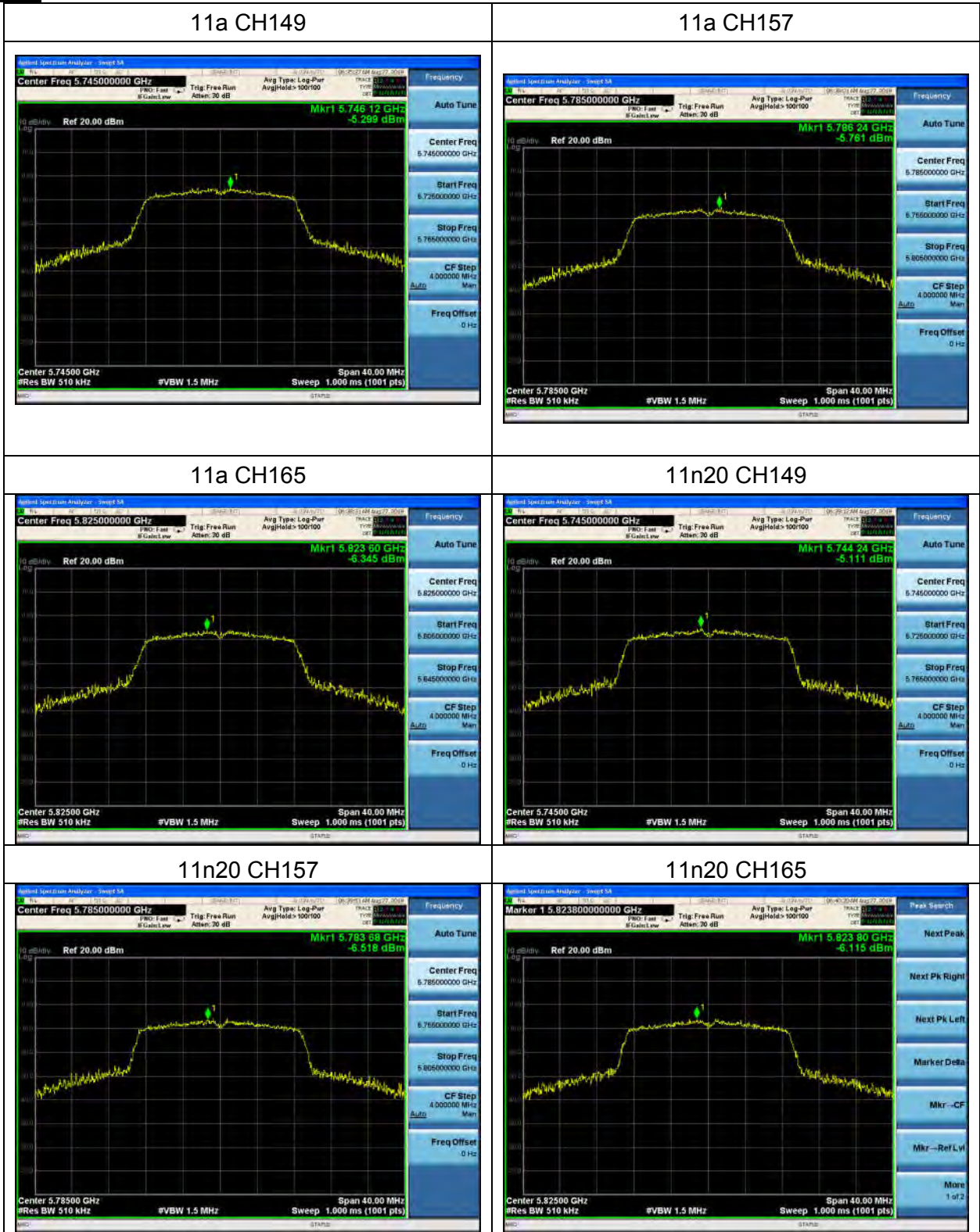

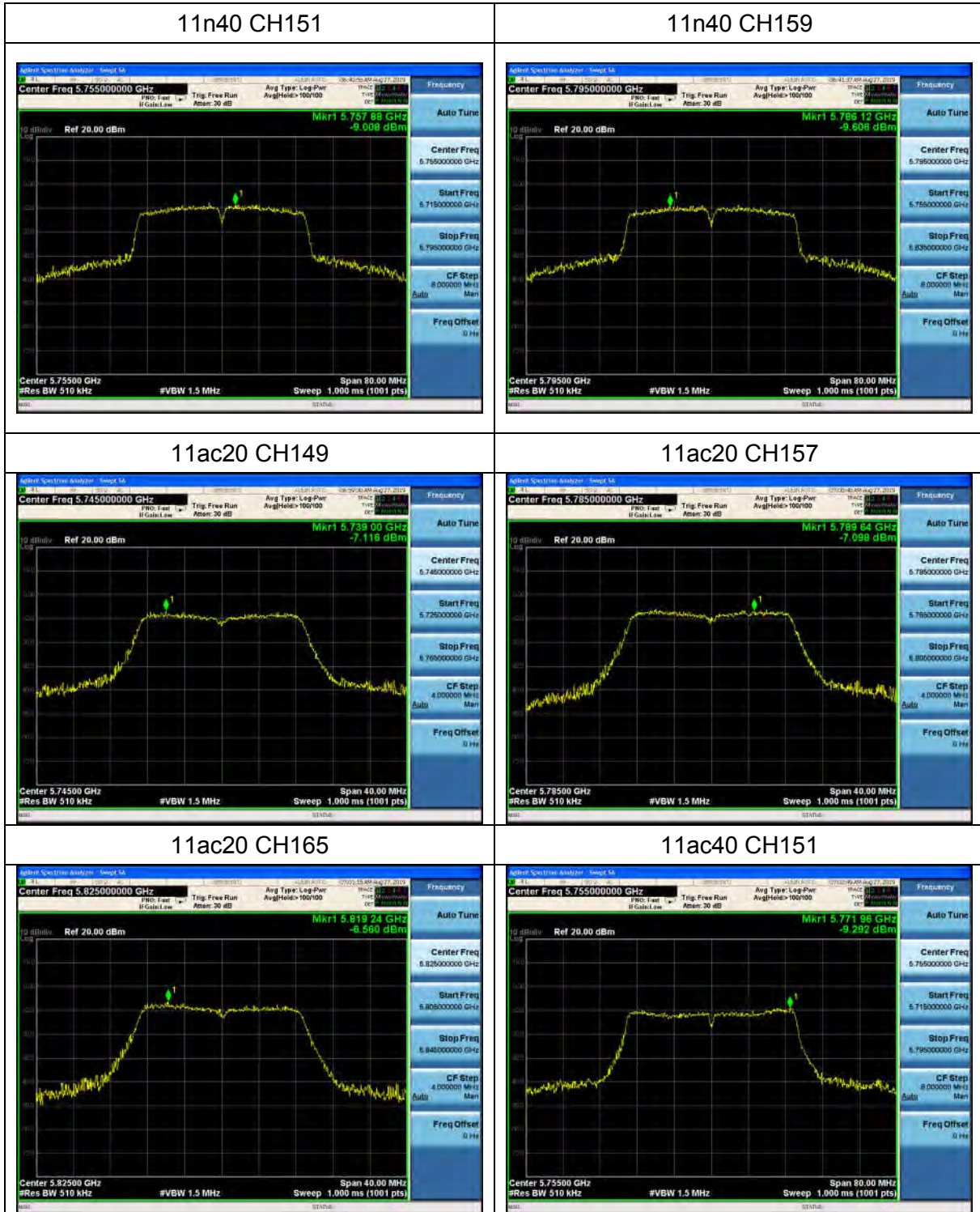

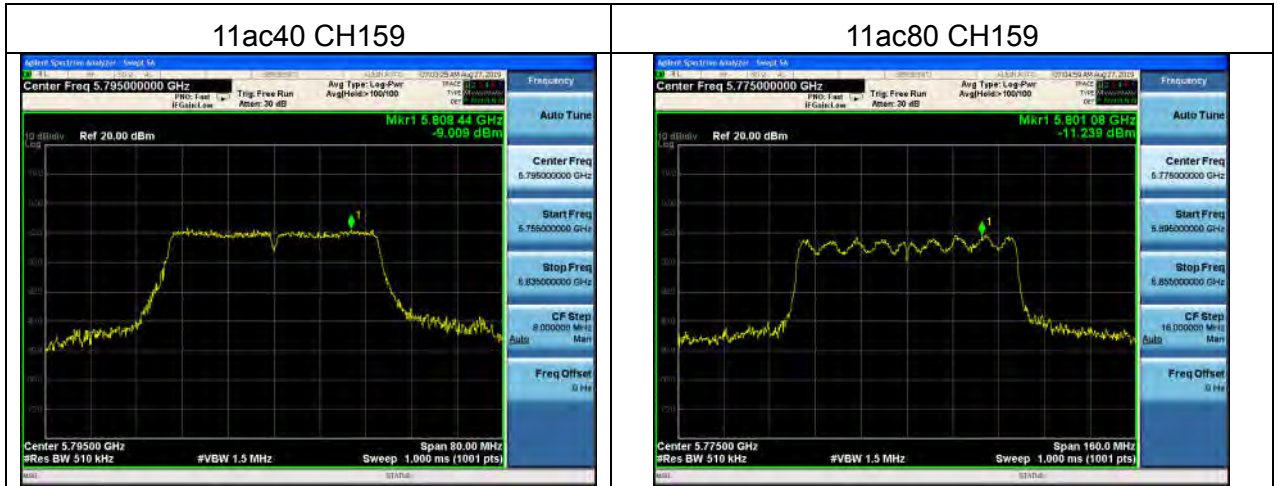

5.9 Frequency Stability Measurement

5.9.1 Limit

Manufactures of U-NII devices are responsible for ensuring frequency stability such that an emission is maintained within the band of operation under all conditions of normal operation as specified in the user's manual.

5.9.2 Test Procedures

1. The transmitter output (antenna port) was connected to the spectrum analyzer.
2. EUT have transmitted absence of modulation signal and fixed channelize.
3. Set the spectrum analyzer span to view the entire absence of modulation emissions bandwidth.
4. Set RBW = 10 kHz, VBW = 10 kHz with peak detector and max hold settings.
5. f_c is declaring of channel frequency. Then the frequency error formula is $(f_c - f) / f_c \times 10^6$ ppm and the limit is less than ± 20 ppm (IEEE 802.11 specification).
6. The test extreme voltage is to change the primary supply voltage from 85 to 115 percent of the nominal value
7. Extreme temperature is $-20^{\circ}\text{C} \sim 70^{\circ}\text{C}$.

5.9.3 Test Setup Layout

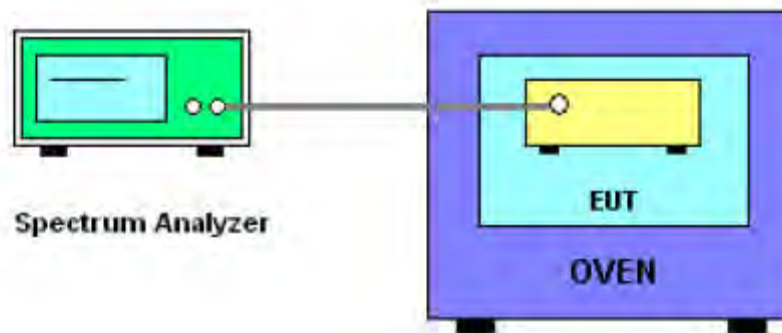

5.9.4 EUT Operation during Test

The EUT was programmed to be in continuously un-modulation transmitting mode.

5.9.5 TEST RESULTS

Note1: The antenna A and antenna B have been tested. The report only shows the worst antenna. The worst case is ANT A.

ANT A
Voltage vs. Frequency Stability

TEST CONDITIONS				Reference Frequency: 5180MHz			
				f	fc	Max. Deviation (MHz)	Max. Deviation (ppm)
T nom (°C)	20	V nom (V)	7.60	5180.0117	5180	0.0117	-2.2587
		V max (V)	8.36	5180.0197	5180	0.0197	-3.8031
		V min (V)	6.84	5180.0124	5180	0.0124	-2.3938
Limits				within 5150-5250MHz			
Result				Complies			

Temperature vs. Frequency Stability

TEST CONDITIONS				Reference Frequency: 5180MHz			
				f	fc	Max. Deviation (MHz)	Max. Deviation (ppm)
V nom (V)	7.6	T (°C)	-20	5180.0123	5180	0.0123	-2.3745
		T (°C)	-10	5180.0135	5180	0.0135	-2.6062
		T (°C)	0	5180.0116	5180	0.0116	-2.2394
		T (°C)	10	5180.0132	5180	0.0132	-2.5483
		T (°C)	20	5180.0110	5180	0.0110	-2.1236
		T (°C)	30	5180.0137	5180	0.0137	-2.6448
		T (°C)	40	5180.0180	5180	0.0180	-3.4749
		T (°C)	50	5180.0147	5180	0.0147	-2.8378
		T (°C)	60	5180.0144	5180	0.0144	-2.7799
		T (°C)	70	5180.0136	5180	0.0136	-2.6255
Limits				within 5150-5250MHz			
Result				Complies			



Voltage vs. Frequency Stability

TEST CONDITIONS				Reference Frequency: 5200MHz			
				f	fc	Max. Deviation (MHz)	Max. Deviation (ppm)
T nom (°C)	20	V nom (V)	7.60	5200.0114	5200	0.0114	-2.1923
		V max (V)	8.36	5200.0140	5200	0.0140	-2.6923
		V min (V)	6.84	5200.0123	5200	0.0123	-2.3654
Limits				within 5150-5250MHz			
Result				Complies			

Temperature vs. Frequency Stability

TEST CONDITIONS				Reference Frequency: 5200MHz			
				f	fc	Max. Deviation (MHz)	Max. Deviation (ppm)
V nom (V)	7.6	T (°C)	-20	5200.0160	5200	0.0160	-3.0769
		T (°C)	-10	5200.0125	5200	0.0125	-2.4038
		T (°C)	0	5200.0170	5200	0.0170	-3.2692
		T (°C)	10	5200.0132	5200	0.0132	-2.5385
		T (°C)	20	5200.0147	5200	0.0147	-2.8269
		T (°C)	30	5200.0141	5200	0.0141	-2.7115
		T (°C)	40	5200.0140	5200	0.0140	-2.6923
		T (°C)	50	5200.0132	5200	0.0132	-2.5385
		T (°C)	60	5200.0129	5200	0.0129	-2.4808
		T (°C)	70	5200.0119	5200	0.0119	-2.2885
Limits				within 5150-5250MHz			
Result				Complies			



Voltage vs. Frequency Stability

TEST CONDITIONS				Reference Frequency: 5240MHz			
				f	fc	Max. Deviation (MHz)	Max. Deviation (ppm)
T nom (°C)	20	V nom (V)	7.60	5240.0106	5240	0.0106	-2.0229
		V max (V)	8.36	5240.0128	5240	0.0128	-2.4427
		V min (V)	6.84	5240.0141	5240	0.0141	-2.6908
Limits				within 5150-5250MHz			
Result				Complies			

Temperature vs. Frequency Stability

TEST CONDITIONS				Reference Frequency: 5240MHz			
				f	fc	Max. Deviation (MHz)	Max. Deviation (ppm)
V nom (V)	7.6	T (°C)	-20	5240.0110	5240	0.0110	-2.0992
		T (°C)	-10	5240.0134	5240	0.0134	-2.5573
		T (°C)	0	5240.0124	5240	0.0124	-2.3664
		T (°C)	10	5240.0124	5240	0.0124	-2.3664
		T (°C)	20	5240.0142	5240	0.0142	-2.7099
		T (°C)	30	5240.0138	5240	0.0138	-2.6336
		T (°C)	40	5240.0121	5240	0.0121	-2.3092
		T (°C)	50	5240.0127	5240	0.0127	-2.4237
		T (°C)	60	5240.0131	5240	0.0131	-2.5000
		T (°C)	70	5240.0133	5240	0.0133	-2.5382
Limits				within 5150-5250MHz			
Result				Complies			

Voltage vs. Frequency Stability

TEST CONDITIONS				Reference Frequency: 5745MHz			
				f	fc	Max. Deviation (MHz)	Max. Deviation (ppm)
T nom (°C)	20	V nom (V)	7.60	5745.00512	5745	0.00512	-0.8918
		V max (V)	8.36	5745.00945	5745	0.00945	-1.6455
		V min (V)	6.84	5745.00927	5745	0.00927	-1.6131
Limits				within 5725-5850MHz			
Result				Complies			

Temperature vs. Frequency Stability

TEST CONDITIONS				Reference Frequency: 5745MHz			
				f	fc	Max. Deviation (MHz)	Max. Deviation (ppm)
V nom (V)	7.6	T (°C)	-20	5745.00936	5745	0.00936	-1.6294
		T (°C)	-10	5745.00899	5745	0.00899	-1.5656
		T (°C)	0	5745.01025	5745	0.01025	-1.7837
		T (°C)	10	5745.00708	5745	0.00708	-1.2315
		T (°C)	20	5745.00793	5745	0.00793	-1.3806
		T (°C)	30	5745.00951	5745	0.00951	-1.6546
		T (°C)	40	5745.00039	5745	0.00039	-0.0686
		T (°C)	50	5745.00713	5745	0.00713	-1.2402
		T (°C)	60	5745.00774	5745	0.00774	-1.3474
		T (°C)	70	5745.00706	5745	0.00706	-1.2295
Limits				within 5725-5850MHz			
Result				Complies			



Voltage vs. Frequency Stability

TEST CONDITIONS				Reference Frequency: 5785MHz			
				f	fc	Max. Deviation (MHz)	Max. Deviation (ppm)
T nom (°C)	20	V nom (V)	7.60	5785.01095	5785	0.01095	-1.8926
		V max (V)	8.36	5785.00461	5785	0.00461	-0.7977
		V min (V)	6.84	5785.00990	5785	0.00990	-1.7115
Limits				within 5725-5850MHz			
Result				Complies			

Temperature vs. Frequency Stability

TEST CONDITIONS				Reference Frequency: 5785MHz			
				f	fc	Max. Deviation (MHz)	Max. Deviation (ppm)
V nom (V)	7.6	T (°C)	-20	5785.00776	5785	0.00776	-1.3412
		T (°C)	-10	5785.01090	5785	0.01090	-1.8842
		T (°C)	0	5785.00901	5785	0.00901	-1.5575
		T (°C)	10	5785.00105	5785	0.00105	-0.1821
		T (°C)	20	5785.00646	5785	0.00646	-1.1169
		T (°C)	30	5785.00169	5785	0.00169	-0.2918
		T (°C)	40	5785.00824	5785	0.00824	-1.4239
		T (°C)	50	5785.00256	5785	0.00256	-0.4433
		T (°C)	60	5785.00398	5785	0.00398	-0.6874
		T (°C)	70	5785.01287	5785	0.01287	-2.2253
Limits				within 5725-5850MHz			
Result				Complies			



Voltage vs. Frequency Stability

TEST CONDITIONS				Reference Frequency: 5825MHz			
				f	fc	Max. Deviation (MHz)	Max. Deviation (ppm)
T nom (°C)	20	V nom (V)	7.60	5825.00287	5825	0.00287	-0.4930
		V max (V)	8.36	5825.00639	5825	0.00639	-1.0967
		V min (V)	6.84	5825.01121	5825	0.01121	-1.9249
Limits				within 5725-5850MHz			
Result				Complies			

Temperature vs. Frequency Stability

TEST CONDITIONS				Reference Frequency: 5825MHz			
				f	fc	Max. Deviation (MHz)	Max. Deviation (ppm)
V nom (V)	7.6	T (°C)	-20	5825.00887	5825	0.00887	-1.5223
		T (°C)	-10	5825.00414	5825	0.00414	-0.7111
		T (°C)	0	5825.00638	5825	0.00638	-1.0947
		T (°C)	10	5825.00345	5825	0.00345	-0.5915
		T (°C)	20	5825.00119	5825	0.00119	-0.2037
		T (°C)	30	5825.00094	5825	0.00094	-0.1606
		T (°C)	40	5825.00906	5825	0.00906	-1.5552
		T (°C)	50	5825.00326	5825	0.00326	-0.5604
		T (°C)	60	5825.00499	5825	0.00499	-0.8561
		T (°C)	70	5825.01044	5825	0.01044	-1.7921
Limits				within 5725-5850MHz			
Result				Complies			



Photographs of the Test Setup

Radiated emission

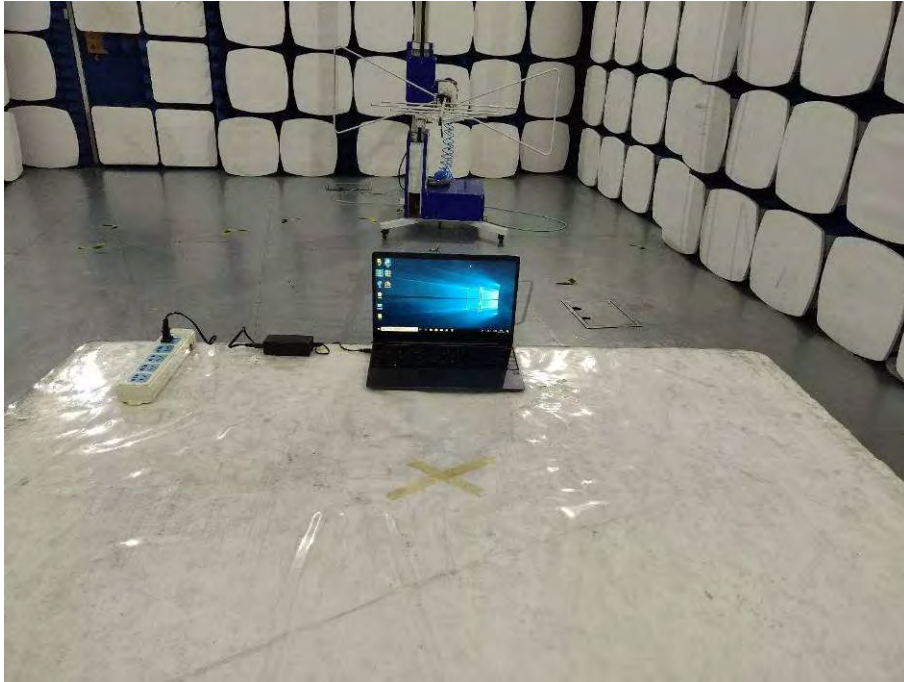



Conducted emission





Photographs of the EUT

See the APPENDIX 1: EUT PHOTO in the report No.: MTi19070804-1E1-1.

----END OF REPORT----