



FCC Part 15C Test Report

FCC ID: 2AHLNFB03H

Product Name:	Intelligent Bracelet With Heart Rate Function
Trademark:	N/A
Model Name :	FB03H B02, B03, B04, B05, B06, B07, B08, B09, B10, FB02H
Prepared For :	Shenzhen Chen Er Technology Limited
Address :	Room 608,Block A,Changyuan New Material Port,No.2 Gaoxin Middle 1st Road,Yuehai Street,Nanshan District, Shenzhen City, China
Prepared By :	Shenzhen BCTC Technology Co., Ltd.
Address :	No.101,Yousong Road,Longhua New District, Shenzhen,China
Test Date:	Feb. 22 – Feb. 28, 2016
Date of Report :	Mar. 2, 2016
Report No.:	BCTC-160201635E



VERIFICATION OF COMPLIANCE

Applicant's name : **Shenzhen Chen Er Technology Limited**
Address..... : Room 608,Block A,Changyuan New Material Port,No.2
Gaoxin Middle 1st Road,Yuehai Street,Nanshan District,
Shenzhen City, China

Manufacture's Name : **Shenzhen Chen Er Technology Limited**
Address..... : Room 608,Block A,Changyuan New Material Port,No.2
Gaoxin Middle 1st Road,Yuehai Street,Nanshan District,
Shenzhen City, China

Product description

Product name : Intelligent Bracelet With Heart Rate Function
Trademark: N/A
Model Name: FB03H
B02, B03, B04, B05, B06, B07, B08, B09, B10, FB02H
Test procedure FCC Part15.249
Standards ANSI C63.10-2013

This device described above has been tested by BCTC, and the test results show that the equipment under test (EUT) is in compliance with the FCC requirements. And it is applicable only to the tested sample identified in the report.

This report shall not be reproduced except in full, without the written approval of BCTC, this document may be altered or revised by BCTC, personal only, and shall be noted in the revision of the document.

Test Result : **Pass**

Testing Engineer : Eric Yang
(Eric Yang)

Technical Manager : Sophie Lee
(Sophia Lee)

Authorized Signatory : Carson Zhang
(Carson. Zhang)





Table of Contents	Page
1 . SUMMARY OF TEST RESULTS	4
1.1 TEST FACILITY	4
1.2 MEASUREMENT UNCERTAINTY	4
2 . GENERAL INFORMATION	5
2.1 GENERAL DESCRIPTION OF EUT	5
2.2 DESCRIPTION OF TEST MODES	6
2.3 TABLE OF PARAMETERS OF TEXT SOFTWARE SETTING	6
2.4 BLOCK DIGRAM SHOWING THE CONFIGURATION OF SYSTEM TESTED	6
2.5 EQUIPMENTS LIST FOR ALL TEST ITEMS	8
3 . EMC EMISSION TEST	9
3.1 RADIATED EMISSION MEASUREMENT	13
3.1.1 RADIATED EMISSION LIMITS	13
3.1.2 TEST PROCEDURE	14
3.1.3 DEVIATION FROM TEST STANDARD	14
3.1.4 TEST SETUP	15
3.1.5 EUT OPERATING CONDITIONS	16
3.1.6 TEST RESULTS	17
4 . BANDWIDTH TEST	21
4.1 APPLIED PROCEDURES / LIMIT	21
4.1.1 TEST PROCEDURE	21
4.1.2 DEVIATION FROM STANDARD	21
4.1.3 TEST SETUP	21
4.1.4 EUT OPERATION CONDITIONS	21
4.1.5 TEST RESULTS	22
5 . 100 KHZ BANDWIDTH OF FREQUENCY BAND EDGE	24
5.1 DEVIATION FROM STANDARD	24
5.2 TEST SETUP	24
5.3 EUT OPERATION CONDITIONS	24
5.4 TEST RESULTS	25
6 . ANTENNA REQUIREMENT	27
6.1 STANDARD REQUIREMENT	27
6.2 EUT ANTENNA	27
7 . EUT TEST PHOTO	28



1. SUMMARY OF TEST RESULTS

Test procedures according to the technical standards:

FCC Part15 (15.249) , Subpart C			
Standard Section	Test Item	Judgment	Remark
15.207	Conducted Emission	PASS	
15.249	Fundamental & Radiated Spurious Emission Measurement	PASS	
15.249	Bandwidth	PASS	
15.205	Band Edge Emission	PASS	
15.203	Antenna Requirement	PASS	

NOTE:

(1) "N/A" denotes test is not applicable in this Test Report

1.1 TEST FACILITY

Shenzhen BCTC Technology Co., Ltd.

Add.:No.101,Yousong Road,Longhua New District, Shenzhen,China

FCC Registration No.:187086

1.2 MEASUREMENT UNCERTAINTY

The reported uncertainty of measurement $y \pm U$, where expanded uncertainty U is based on a standard uncertainty multiplied by a coverage factor of $k=2$, providing a level of confidence of approximately **95 %** .

No.	Item	Uncertainty
1	Conducted Emission Test	$\pm 1.38\text{dB}$
2	RF power,conducted	$\pm 0.16\text{dB}$
3	Spurious emissions,conducted	$\pm 0.21\text{dB}$
4	All emissions,radiated(<1G)	$\pm 4.68\text{dB}$
5	All emissions,radiated(>1G)	$\pm 4.89\text{dB}$
6	Temperature	$\pm 0.5^{\circ}\text{C}$
7	Humidity	$\pm 2\%$



2. GENERAL INFORMATION

2.1 GENERAL DESCRIPTION OF EUT

Product Name:	Intelligent Bracelet With Heart Rate Function
Model No.:	FB03H B02, B03, B04, B05, B06, B07, B08, B09, B10, FB02H
Operation Frequency:	BT:2402~2480MHz
Modulation technology:	GFSK
BT Version	4.0 BLE
Antenna Type:	Integral Antenna
Antenna gain:	1.0 dBi
Power supply:	DC 5V from adapter Rechargeable lithium-ion battery 3.7V
Adapter	--
Connecting I/O Port(s)	Please refer to the User's Manual
hardware version	--
Software version	--
Serial number	--

Note:

1. For a more detailed features description, please refer to the manufacturer's specifications or the User's Manual.
- 2.

Channel List					
Channel	Frequency (MHz)				
01	2402				
02	2406				
03	2408				
~	~				
39	2478				
40	2480				

3. The product are different for mode names,outlook color, screen size and panel material.



2.2 DESCRIPTION OF TEST MODES

To investigate the maximum EMI emission characteristics generated from EUT, the test system was pre-scanning tested based on the consideration of following EUT operation mode or test configuration mode which possibly have effect on EMI emission level. Each of these EUT operation mode(s) or test configuration mode(s) mentioned above was evaluated respectively.

For Conducted & Radiated Emission	
Final Test Mode	Description
Mode 1	CH01
Mode 2	CH20
Mode 3	CH40
Mode 4	Normal Link

Note:

- (1) The measurements are performed at the highest, middle, lowest available channels.
- (2) Fully-charged battery is used during the test

2.3 TABLE OF PARAMETERS OF TEST SOFTWARE SETTING

During testing channel & power controlling software provided by the customer was used to control the operating channel as well as the output power level. The RF output power selection is for the setting of RF output power expected by the customer and is going to be fixed on the firmware of the final end product power parameters of FHSS

Frequency	2402 MHz	2440 MHz	2480 MHz
Channel	Low	Middle	High

2.4 BLOCK DIAGRAM SHOWING THE CONFIGURATION OF SYSTEM TESTED

Conducted Emission Test

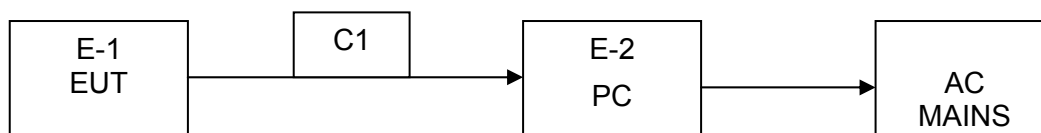

Radiation Emission Test

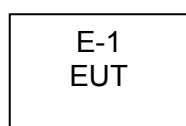



2.5 DESCRIPTION OF SUPPORT UNITS(CONDUCTED MODE)

The EUT has been tested as an independent unit together with other necessary accessories or support units. The following support units or accessories were used to form a representative test configuration during the tests.

Item	Equipment	Mfr/Brand	Model/Type No.	Series No.	Note
E-1	Intelligent Bracelet With Heart Rate Function	N/A	FB03H	N/A	EUT
E-2	PC	ASUS	ATW8000	N/A	N/A

Item	Shielded Type	Ferrite Core	Length	Note
C1	NO Shielded	NO	0.8M	Mini USB cable

Note:

- (1) The support equipment was authorized by Declaration of Confirmation.
- (2) For detachable type I/O cable should be specified the length in cm in 『Length』 column.
- (3) “YES” is means “shielded” “with core”; “NO” is means “unshielded” “without core”.



2.6 EQUIPMENTS LIST FOR ALL TEST ITEMS

Conduction Test equipment

Equipment	Manufacturer	Model No.	Serial No.	Last Cal.	Next Cal.
Test Receiver	R&S	ESCI	101160	2015.06.07	2016.06.06
LISN	SCHWARZBECK	ENV216	101313	2015.08.25	2016.08.24
LISN	EMCO	3816/2	00042990	2015.08.25	2016.08.24
50Ω Coaxial Switch	Anritsu	MP59B	6200264417	2015.06.07	2016.06.06
RF cables	R&S	R204	R20X	2015.07.06	2015.07.05

Radiation test, Band-edge test and 20db bandwidth test equipment

Equipment	Manufacturer	Model No.	Serial No.	Last Cal.	Next Cal.
Test Receiver	R&S	ESPI	101318	2015.06.07	2016.06.06
System Simulator	Agilent	E5515C	GB43130252	2015.06.07	2016.06.06
Power Splitter	Weinschel	1506A	NW534	2015.06.07	2016.06.06
Bilog Antenna	TESEQ	CBL6111D	31216	2015.07.06	2016.07.05
Bilog Antenna	TESEQ	CBL6111D	31217	2015.06.07	2017.06.06
Loop antenna	ARA	PLA-1030/B	1029	2015.06.07	2016.06.06
Spectrum Analyzer	Agilent	E4411B	MY4511235	2015.07.06	2016.07.05
Signal Amplifier	SONOMA	313	187022	2015.07.06	2016.07.05
Signal Amplifier	Agilent	8449B	3008A00213	2015.07.06	2016.07.05
RF Cable	R&S	R203	R20X	2015.07.06	2016.07.05
MULTI-DEVICE Controller	ETS-LINDGREEN	31250	126821	N/A	N/A
Horn Antenna	EM	EM-AH-10180	2011071402	2015.07.06	2016.07.05
Horn Antenna	EM	EM-AH-10180	2011071401	2015.06.07	2017.06.06
Horn Antenna	Schwarzbeck	BBHA 9170	9170-181	2015.07.06	2016.07.05
Spectrum Analyzer	Agilent	8593E	3911A03928	2015.07.06	2016.07.05
Spectrum Analyzer	Agilent	E4407B	MY45108040	2015.07.06	2016.07.05
Signal Amplifier	DAZE	ZN3380B	11235	2015.08.25	2016.08.24
High Pass filter	KANGMAI	WHKX1.0/1.5G-10SS	40	2015.08.25	2016.08.24
Filter	COM-MW	ZBSF-C836.5-25-X	BCTC042	2015.08.25	2016.08.24
Filter	COM-MW	ZBSF-C1747.5-75-X2	BCTC045	2015.08.25	2016.08.24
Filter	COM-MW	ZBSF-C1880-60-X2	BCTC047	2015.08.25	2016.08.24
DC Power Supply	LongWei	PS-305D	010965682	2015.07.06	2016.07.05
Constant temperature and humidity box	GF	GTH-800-40-2P	MAA9906-012	2015.06.07	2016.06.06
Universal radio communication tester	R&S	CMU200	115295	2015.08.25	2016.08.24
Splitter	Agilent	11435B	1125162	2015.07.06	2016.07.05



3. EMC EMISSION TEST

3.1 CONDUCTED EMISSION MEASUREMENT

3.1.1 POWER LINE CONDUCTED EMISSION Limits (Frequency Range 150KHz-30MHz)

FREQUENCY (MHz)	Class A (dBuV)		Class B (dBuV)		Standard
	Quasi-peak	Average	Quas -peak	Average	
0.15 -0.5	79.00	66.00	66 - 56 *	56 - 46 *	CISPR
0.50 -5.0	73.00	60.00	56.00	46.00	CISPR
5.0 -30.0	73.00	60.00	60.00	50.00	CISPR

0.15 -0.5	79.00	66.00	66 - 56 *	56 - 46 *	FCC
0.50 -5.0	73.00	60.00	56.00	46.00	FCC
5.0 -30.0	73.00	60.00	60.00	50.00	FCC

Note:

- (1) The tighter limit applies at the band edges.
- (2) The limit of " * " marked band means the limitation decreases linearly with the logarithm of the frequency in the range.

The following table is the setting of the receiver

Receiver Parameters	Setting
Attenuation	10 dB
Start Frequency	0.15 MHz
Stop Frequency	30 MHz
IF Bandwidth	9 kHz

3.1.2 TEST PROCEDURE

- The EUT was placed 0.8 meters from the horizontal ground plane with EUT being connected to the power mains through a line impedance stabilization network (LISN). All other support equipments powered from additional LISN(s). The LISN provide 50 Ohm/ 50uH of coupling impedance for the measuring instrument.
- Interconnecting cables that hang closer than 40 cm to the ground plane shall be folded back and forth in the center forming a bundle 30 to 40 cm long.
- I/O cables that are not connected to a peripheral shall be bundled in the center. The end of the cable may be terminated, if required, using the correct terminating impedance. The overall length shall not exceed 1 m.
- LISN at least 80 cm from nearest part of EUT chassis.
- For the actual test configuration, please refer to the related Item –EUT Test Photos.

3.1.3 DEVIATION FROM TEST STANDARD

No deviation

3.1.4 TEST SETUP

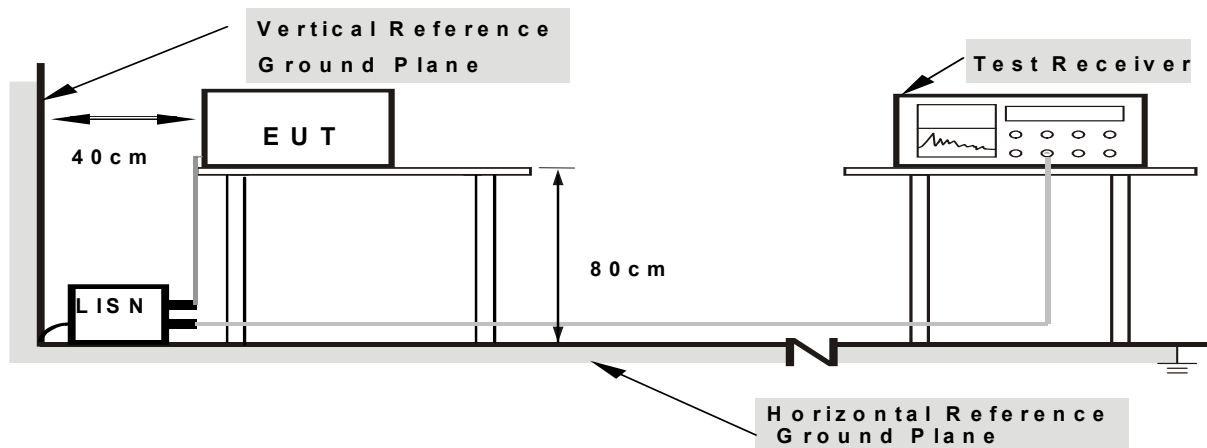

Note: 1. Support units were connected to second LISN.

2. Both of LISNs (AMN) are 80 cm from EUT and at least 80 cm from other units and other metal planes

3.1.5 EUT OPERATING CONDITIONS

The EUT was configured for testing in a typical fashion (as a customer would normally use it). The EUT has been programmed to continuously transmit during test. This operating condition was tested and used to collect the included data.

We pretest AC 120V and AC 240V, the worst voltage was AC 120V and the data recording in the report.



3.1.6 TEST RESULTS

EUT :	Intelligent Bracelet With Heart Rate Function	Model Name. :	FB03H
Temperature :	26°C	Relative Humidity :	54%
Pressure :	1010hPa	Phase :	L
Test Voltage :	AC120V/60Hz	Test Mode :	Mode 4

No.	Mk.	Freq.	Reading Level	Correct Factor	Measurement	Limit	Over	Detector	Comment
		MHz	dBuV	dB	dBuV	dBuV	dB		
1	*	0.1660	42.94	10.06	53.00	65.15	-12.15	QP	
2		0.1660	30.52	10.06	40.58	55.15	-14.57	AVG	
3		0.2819	31.80	10.09	41.89	60.76	-18.87	QP	
4		0.2819	14.41	10.09	24.50	50.76	-26.26	AVG	
5		0.7740	22.10	10.14	32.24	56.00	-23.76	QP	
6		0.7740	13.91	10.14	24.05	46.00	-21.95	AVG	
7		6.0020	19.90	10.09	29.99	60.00	-30.01	QP	
8		6.0020	-0.31	10.09	9.78	50.00	-40.22	AVG	
9		13.0260	30.89	10.14	41.03	60.00	-18.97	QP	
10		13.0260	22.20	10.14	32.34	50.00	-17.66	AVG	
11		17.8740	17.05	10.16	27.21	60.00	-32.79	QP	
12		17.8740	9.23	10.16	19.39	50.00	-30.61	AVG	

Remark:

1. All readings are Quasi-Peak and Average values.
2. Factor = Insertion Loss + Cable Loss.

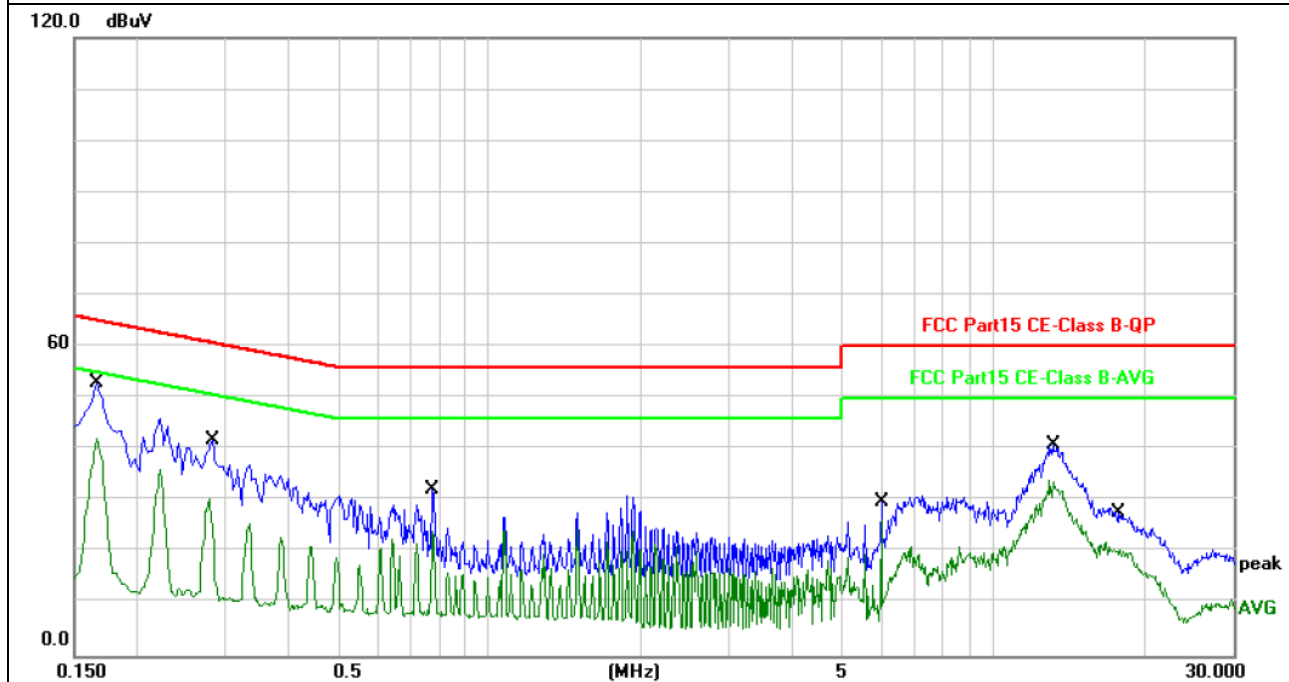



EUT :	Intelligent Bracelet With Heart Rate Function	Model Name. :	FB03H
Temperature :	26°C	Relative Humidity :	54%
Pressure :	1010hPa	Phase :	N
Test Voltage :	AC120V/60Hz	Test Mode :	Mode 4

No.	Mk.	Freq.	Reading Level	Correct Factor	Measurement	Limit	Over	Detector	Comment
		MHz	dBuV	dB	dBuV	dBuV	dB		
1	*	0.1650	43.84	10.06	53.90	65.20	-11.30	QP	
2		0.1650	31.39	10.06	41.45	55.20	-13.75	AVG	
3		0.3268	28.71	10.10	38.81	59.53	-20.72	QP	
4		0.3268	11.51	10.10	21.61	49.53	-27.92	AVG	
5		0.7660	21.93	10.14	32.07	56.00	-23.93	QP	
6		0.7660	6.50	10.14	16.64	46.00	-29.36	AVG	
7		4.0060	16.49	10.16	26.65	56.00	-29.35	QP	
8		4.0060	-3.51	10.16	6.65	46.00	-39.35	AVG	
9		6.8260	26.18	10.10	36.28	60.00	-23.72	QP	
10		6.8260	16.15	10.10	26.25	50.00	-23.75	AVG	
11		14.6940	21.67	10.15	31.82	60.00	-28.18	QP	
12		14.6940	13.71	10.15	23.86	50.00	-26.14	AVG	

Remark:

1. All readings are Quasi-Peak and Average values.
2. Factor = Insertion Loss + Cable Loss.

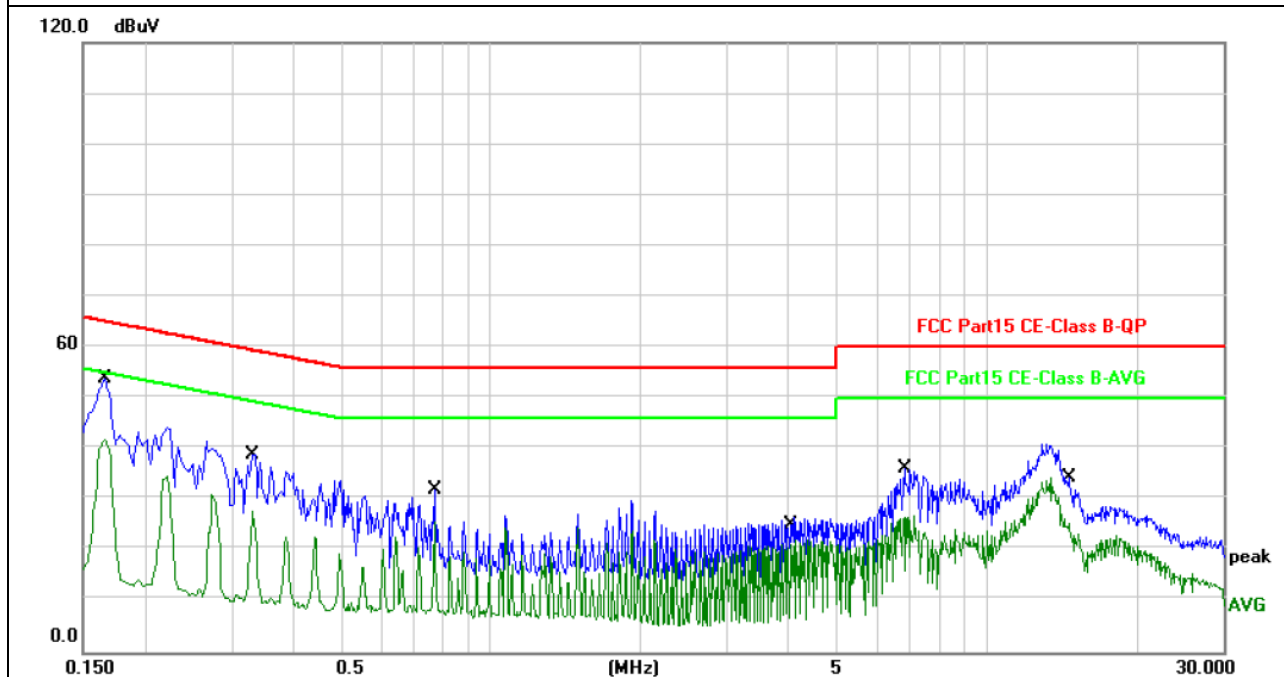



3.2 RADIATED EMISSION MEASUREMENT

3.2.1 RADIATED EMISSION LIMITS (Frequency Range 9kHz-1000MHz)

20dBc in any 100 kHz bandwidth outside the operating frequency band. In case the emission fall within the restricted band specified on 15.205(a), then the 15.209(a) limit in the table below has to be followed.

Frequencies (MHz)	Field Strength (micorvolts/meter)	Measurement Distance (meters)
0.009~0.490	2400/F(KHz)	300
0.490~1.705	24000/F(KHz)	30
1.705~30.0	30	30
30~88	100	3
88~216	150	3
216~960	200	3
Above 960	500	3

LIMITS OF RADIATED EMISSION MEASUREMENT (Above 1000MHz)

FREQUENCY (MHz)	Class B (dBuV/m) (at 3M)	
	PEAK	AVERAGE
Above 1000	74	54

Notes:

- (1) The limit for radiated test was performed according to FCC PART 15C.
- (2) The tighter limit applies at the band edges.
- (3) Emission level (dBuV/m)=20log Emission level (uV/m).

FREQUENCY RANGE OF RADIATED MEASUREMENT (For unintentional radiators)

Highest frequency generated or Upper frequency of measurement used in the device or on which the device operates or tunes (MHz)	Range (MHz)
Below 1.705	30
1.705 – 108	1000
108 – 500	2000
500 – 1000	5000
Above 1000	5 th harmonic of the highest frequency or 40 GHz, whichever is lower



Spectrum Parameter	Setting
Attenuation	Auto
Start Frequency	1000 MHz
Stop Frequency	10th carrier harmonic
RB / VB (emission in restricted band)	1 MHz / 1 MHz for Peak, 1 MHz / 10Hz for Average

Receiver Parameter	Setting
Attenuation	Auto
Start ~ Stop Frequency	9kHz~150kHz / RB 200Hz for QP
Start ~ Stop Frequency	150kHz~30MHz / RB 9kHz for QP
Start ~ Stop Frequency	30MHz~1000MHz / RB 120kHz for QP

3.2.2 TEST PROCEDURE

- a. The measuring distance of at 3 m shall be used for measurements at frequency up to 25GHz. For frequencies above 1GHz, any suitable measuring distance may be used.
- b. The EUT was placed on the top of a rotating table 0.8 and 1.5 meters above the ground at a 3 meter semi-chamber test. The table was rotated 360 degrees to determine the position of the highest radiation.
- c. The height of the equipment or of the substitution antenna shall be 0.8 m; above 1GHz, the height was 1.5m, the height of the test antenna shall vary between 1 m to 4 m. Both horizontal and vertical polarizations of the antenna are set to make the measurement.
- d. The initial step in collecting conducted emission data is a spectrum analyzer peak detector mode pre-scanning the measurement frequency range. Significant peaks are then marked and then Quasi Peak detector mode re-measured.
- e. If the Peak Mode measured value compliance with and lower than Quasi Peak Mode Limit, the EUT shall be deemed to meet QP Limits and then no additional QP Mode measurement performed.
- f. For the actual test configuration, please refer to the related Item –EUT Test Photos.
- g. For the radiated emission test above 1GHz:
Place the measurement antenna away from each area of the EUT determined to be a source of emissions at the specified measurement distance, while keeping the measurement antenna aimed at the source of emissions at each frequency of significant emissions, with polarization oriented for maximum response.
The measurement antenna may have to be higher or lower than the EUT, depending on the radiation pattern of the emission and staying aimed at the emission source for receiving the maximum signal. The final measurement antenna elevation shall be that which maximizes the emissions. The measurement antenna elevation for maximum emissions shall be restricted to a range of heights of from 1 m to 4 m above the ground or reference ground plane.

Note:

Both horizontal and vertical antenna polarities were tested and performed pretest to three orthogonal axis. The worst case emissions were reported

3.2.3 DEVIATION FROM TEST STANDARD

No deviation

3.2.4 TEST SETUP

(A) Radiated Emission Test-Up Frequency Below 30MHz

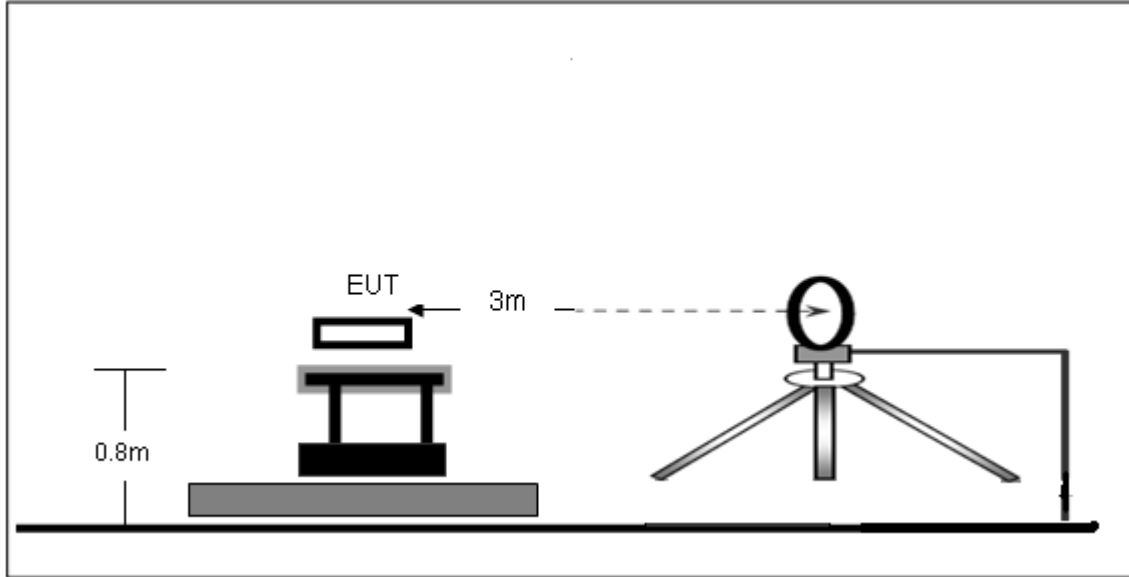

(B) Radiated Emission Test-Up Frequency 30MHz~1GHz

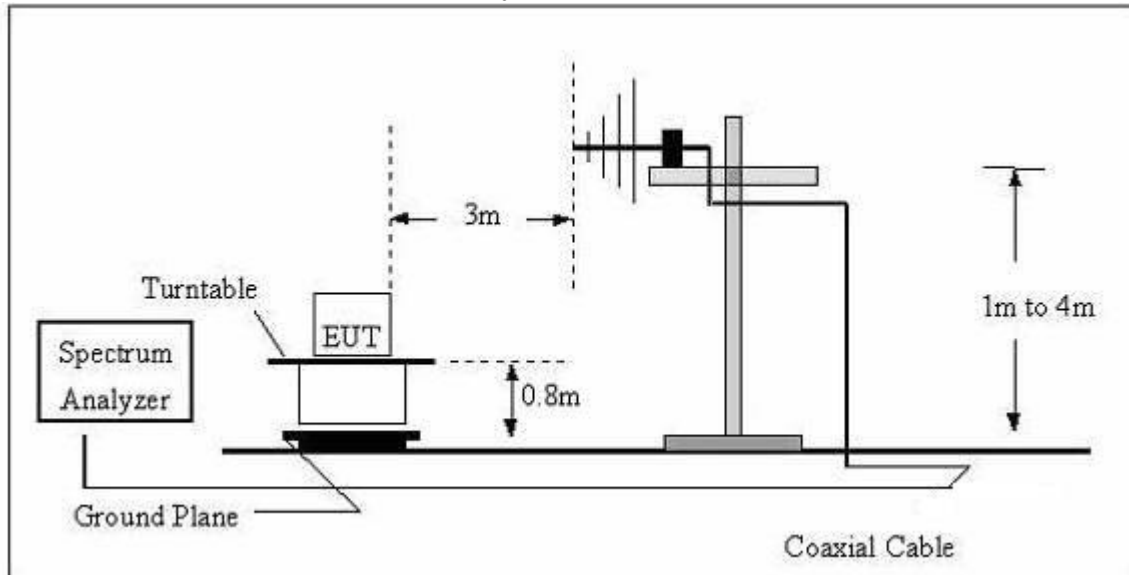

(C) Radiated Emission Test-Up Frequency Above 1GHz

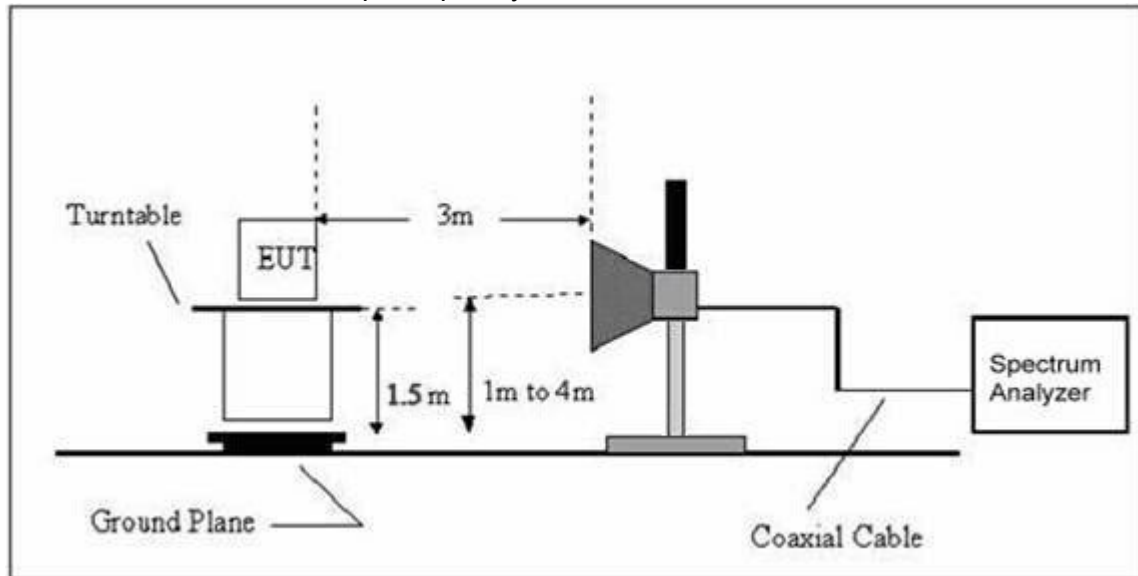

3.2.5 EUT OPERATING CONDITIONS

The EUT tested system was configured as the statements of 2.4 Unless otherwise a special operating condition is specified in the follows during the testing.



3.2.6 TEST RESULTS

Radiated Spurious Emission (Below 30MHz)

EUT :	Intelligent Bracelet With Heart Rate Function	Model Name :	FB03H
Temperature :	20 °C	Relative Humidity :	48%
Pressure :	1010 hPa	Polarization :	---
Test Voltage :	AC 120V/60Hz		
Test Mode :	Mode 4		

Freq. (MHz)	Reading (dBuV/m)	Limit (dBuV/m)	Margin (dB)	State P/F
--	--	--	--	PASS
--	--	--	--	PASS

NOTE:

The amplitude of spurious emissions which are attenuated by more than 20dB below the permissible value has no need to be reported.

Distance extrapolation factor = $40 \log(\text{specific distance}/\text{test distance})$ (dB);

Limit line = specific limits(dBuv) + distance extrapolation factor.



Radiated Spurious Emission (Between 30MHz – 1GHz)

EUT :	Intelligent Bracelet With Heart Rate Function	Model Name :	FB03H
Temperature :	26 °C	Relative Humidity :	54%
Pressure :	1010 hPa	Polarization :	Horizontal
Test Voltage :	AC 120V/60Hz		
Test Mode : (Worst)	Mode 4		

No.	Mk.	Freq. MHz	Reading Level dBuV	Correct Factor dB/m	Measure- ment dBuV/m	Limit dBuV/m	Over dB	Detector	Antenna Height cm	Table Degree degree	Comment
1		35.1278	38.61	-8.51	30.10	40.00	-9.90	QP			
2		46.1779	35.74	-9.66	26.08	40.00	-13.92	QP			
3		87.7248	41.16	-17.79	23.37	40.00	-16.63	QP			
4		129.9226	46.06	-14.11	31.95	43.50	-11.55	QP			
5		252.9482	47.43	-14.12	33.31	46.00	-12.69	QP			
6	*	324.4561	51.13	-11.95	39.18	46.00	-6.82	QP			

Remark:

Factor = Antenna Factor + Cable Loss – Pre-amplifier.

All interfaces was connected, and BT TX mode was link.

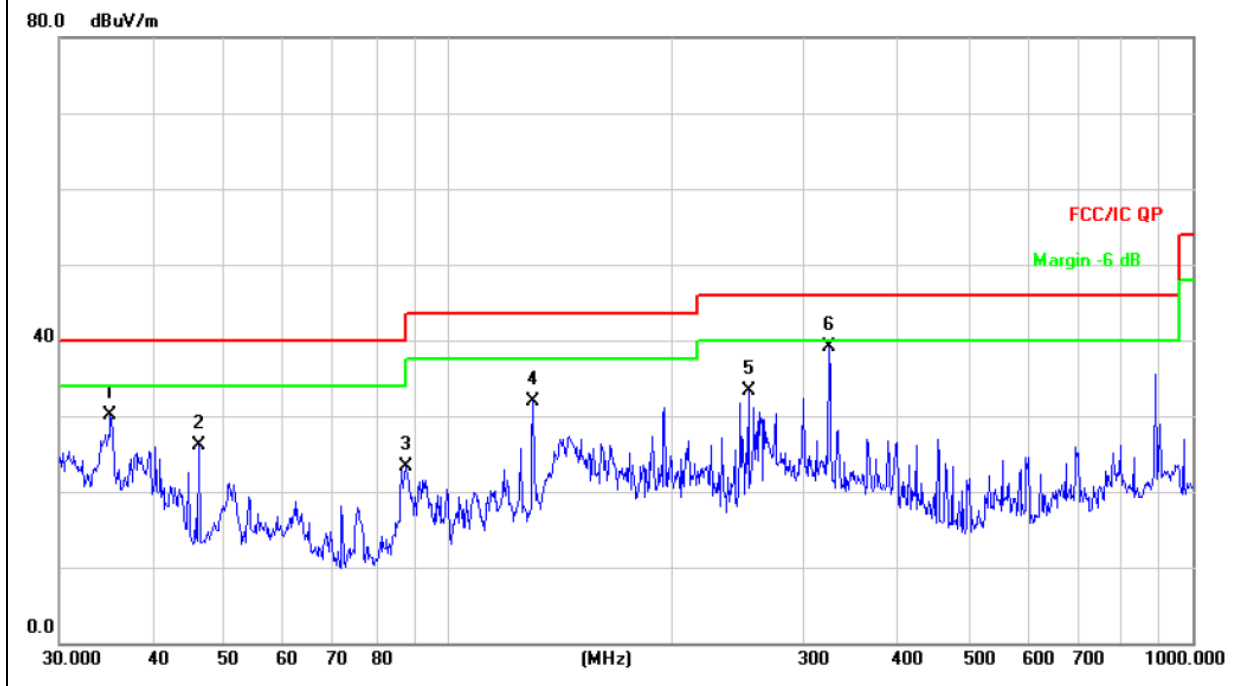



EUT :	Intelligent Bracelet With Heart Rate Function	Model Name :	FB03H
Temperature :	26 °C	Relative Humidity :	54%
Pressure :	1010 hPa	Polarization :	Vertical
Test Voltage :	AC 120V/60Hz		
Test Mode : (Worst)	Mode 4		

No.	Mk.	Freq.	Reading Level	Correct Factor	Measurement	Limit	Over	Antenna Height	Table Degree
		MHz	dBuV	dB/m	dBuV/m	dBuV/m	dB	cm	degree
1	*	34.7602	44.58	-8.49	36.09	40.00	-3.91	QP	
2		87.1117	51.39	-17.87	33.52	40.00	-6.48	QP	
3		129.9226	45.56	-14.11	31.45	43.50	-12.05	QP	
4		315.4808	43.62	-12.18	31.44	46.00	-14.56	QP	
5		554.8254	38.34	-6.96	31.38	46.00	-14.62	QP	
6		903.3094	27.59	-1.39	26.20	46.00	-19.80	QP	

Remark:

Factor = Antenna Factor + Cable Loss – Pre-amplifier.

All interfaces was connected, and BT TX mode was link.

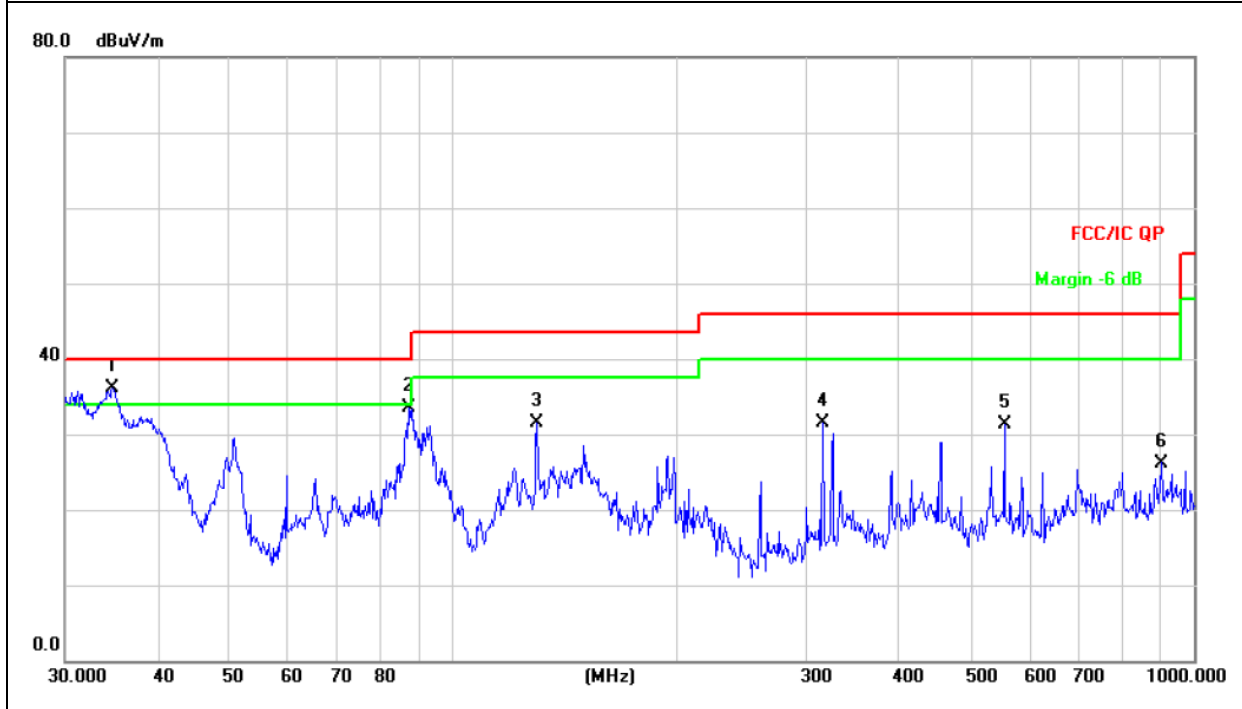



Radiated Spurious Emission (1GHz to 25GHz)
GFSK

	Freq.	Receiver Reading	Detector	Polar	Corrected Factor	Emission Level	Limit	Result
	(MHz)	(dBμV)	(PK/QP/Ave)	(H/V)	(dB)	(dBμV/m)	(dBμV/m)	
Lower Channel 2402MHz	2402.00	103.85	PK	H	1.31	105.27	114.00	Pass
	2402.00	89.64	Ave	H	1.31	91.06	94.00	Pass
	4804.00	56.72	PK	H	-1.06	55.74	74.00	Pass
	4804.00	46.74	Ave	H	-1.06	45.76	54.00	Pass
	2402.00	103.69	PK	V	1.31	105.11	114.00	Pass
	2402.00	88.87	Ave	V	1.31	90.29	94.00	Pass
	4804.00	55.75	PK	V	-1.06	54.77	74.00	Pass
	4804.00	45.83	Ave	V	-1.06	44.85	54.00	Pass
Middle Channel 2440MHz	2440.00	103.11	PK	H	0.85	103.84	114.00	Pass
	2440.00	88.39	Ave	H	0.85	89.12	94.00	Pass
	4880.00	57.62	PK	H	-0.62	55.80	74.00	Pass
	4880.00	48.51	Ave	H	-0.62	46.69	54.00	Pass
	2440.00	103.39	PK	V	0.85	104.12	114.00	Pass
	2440.00	88.43	Ave	V	0.85	89.16	94.00	Pass
	4882.00	57.54	PK	V	-0.62	55.72	74.00	Pass
	4882.00	47.94	Ave	V	-0.62	46.12	54.00	Pass
Upper Channel 2480MHz	2480.00	103.59	PK	H	0.53	104.28	114.00	Pass
	2480.00	89.00	Ave	H	0.53	89.69	94.00	Pass
	4960.00	57.84	PK	H	-0.24	56.07	74.00	Pass
	4960.00	49.71	Ave	H	-0.24	47.94	54.00	Pass
	2480.00	103.00	PK	V	0.53	103.69	114.00	Pass
	2480.00	88.38	Ave	V	0.53	89.07	94.00	Pass
	4960.00	57.80	PK	V	-0.24	56.03	74.00	Pass
	4960.00	49.37	Ave	V	-0.24	47.60	54.00	Pass

Remark:

Factor = Antenna Factor + Cable Loss – Pre-amplifier.

Emission Level = Meter Reading + Factor

Margin = Emission Level - Limit

Other harmonics emissions are lower than 20dB below the allowable limit.



4. BANDWIDTH TEST

4.1 APPLIED PROCEDURES / LIMIT

FCC Part15 (15.249) , Subpart C				
Section	Test Item	Limit	Frequency Range (MHz)	Result
15.249	Bandwidth	(20dB bandwidth)	2400-2483.5	PASS

Spectrum Parameter	Setting
Attenuation	Auto
Span Frequency	> Measurement Bandwidth or Channel Separation
RB	30KHz
VB	\geq RBW
Detector	Peak
Trace	Max Hold
Sweep Time	Auto

4.1.1 TEST PROCEDURE

- The EUT was directly connected to the spectrum analyzer and antenna output port as show in the block diagram below,
- Spectrum Setting : RBW= 100KHz, VBW \geq RBW, Sweep time = Auto.

4.1.2 DEVIATION FROM STANDARD

No deviation.

4.1.3 TEST SETUP

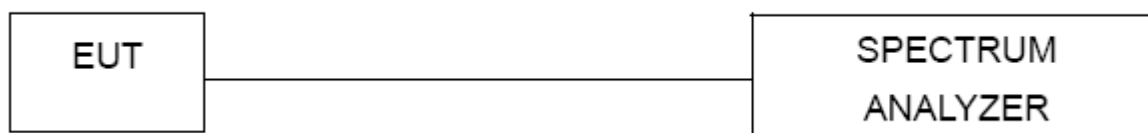

4.1.4 EUT OPERATION CONDITIONS

The EUT tested system was configured as the statements of 2.4 Unless otherwise a special operating condition is specified in the follows during the testing.



4.1.5 TEST RESULTS

EUT :	Intelligent Bracelet With Heart Rate Function	Model Name :	FB03H
Temperature :	25 °C	Relative Humidity :	60%
Pressure :	1012 hPa	Test Voltage :	AC 120V/60Hz
Test Mode :	CH01 / CH20 /CH40		

	Frequency	20dB Bandwidth (MHz)	Result
GFSK	2402 MHz	1.064	PASS
	2440 MHz	1.136	PASS
	2480 MHz	1.088	PASS

GFSK

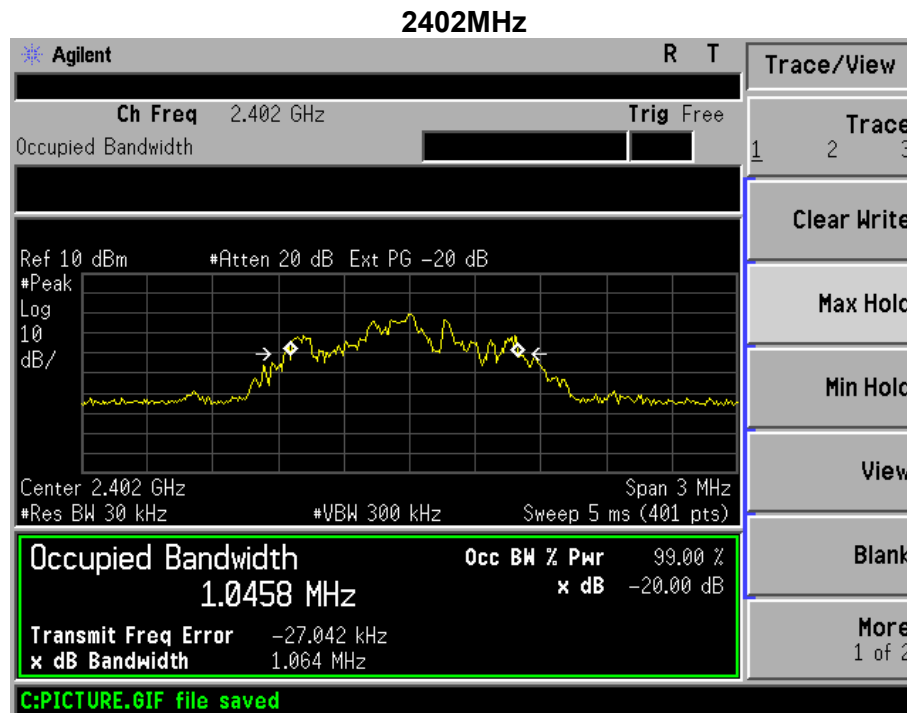



2440 MHz

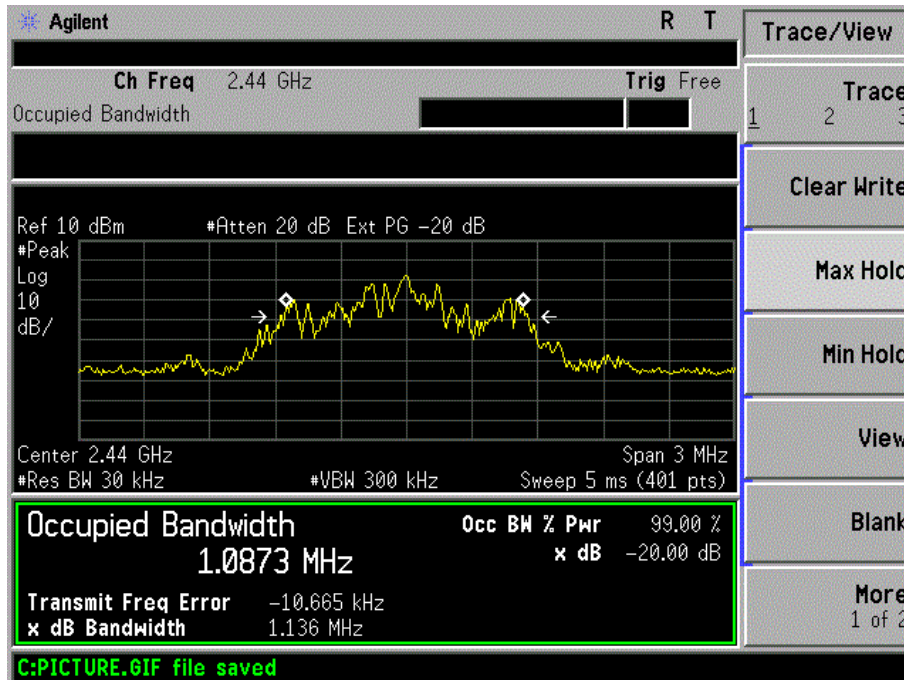

2480 MHz





5. BAND EDGE EMISSION APPLICABLE STANDARD

In any 100 kHz bandwidth outside the frequency band in which the spread spectrum or digitally modulated intentional radiator is operating, the radio frequency power that is produced by the intentional radiator shall be at least 20 dB below that in the 100 kHz bandwidth within the band that contains the highest level of the desired power, based on either an RF conducted or a radiated measurement, provided the transmitter demonstrates compliance with the peak conducted power limits. If the transmitter complies with the conducted power limits based on the use of RMS averaging over a time interval, as permitted under paragraph (b)(3) of this section, the attenuation required under this paragraph shall be 30 dB instead of 20 dB. Attenuation below the general limits specified in §15.209(a) is not required. In addition, radiated emissions which fall in the restricted bands, as defined in §15.205(a), must also comply with the radiated emission limits specified in §15.209(a) (see §15.205(c)).

TEST PROCEDURE

- a. For radiated, please see item 3.2.2
- b. For conducted, please see item 4.1.4

5.1 DEVIATION FROM STANDARD

No deviation.

5.2 TEST SETUP

5.3 EUT OPERATION CONDITIONS

The EUT tested system was configured as the statements of 2.4 Unless otherwise a special operating condition is specified in the follows during the testing.



5.4 TEST RESULTS

EUT :	Intelligent Bracelet With Heart Rate Function	Model Name :	FB03H
Temperature :	25 °C	Relative Humidity :	60%
Pressure :	1012 hPa	Test Voltage :	AC 120V/60Hz
Test Mode :	CH01/ CH40	Polarization :	Horizontal

Frequency (MHz)	Antenna polarization (H/V)	Worst Frequency (MHz)	Factor	Emission (dBuV/m)	Band edge Limit (dBuV/m)		Result
			dB	PK	PK	AV	
<2400	H	2400.00	1.31	44.82	74.00	54.00	Pass
<2400	V	2400.00	1.31	44.54	74.00	54.00	Pass
>2483.5	H	2485.30	1.29	44.93	74.00	54.00	Pass
>2483.5	V	2485.30	1.29	44.44	74.00	54.00	Pass

The plot only show the worst mode hopping mode on Horizontal

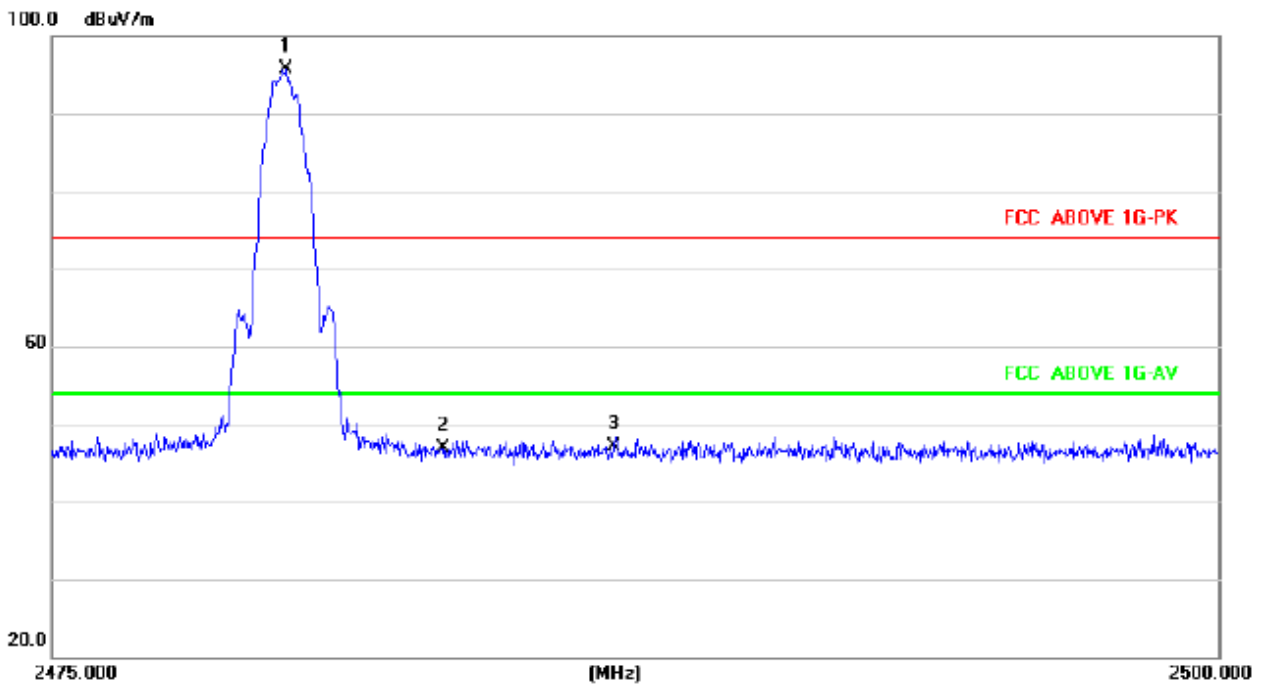
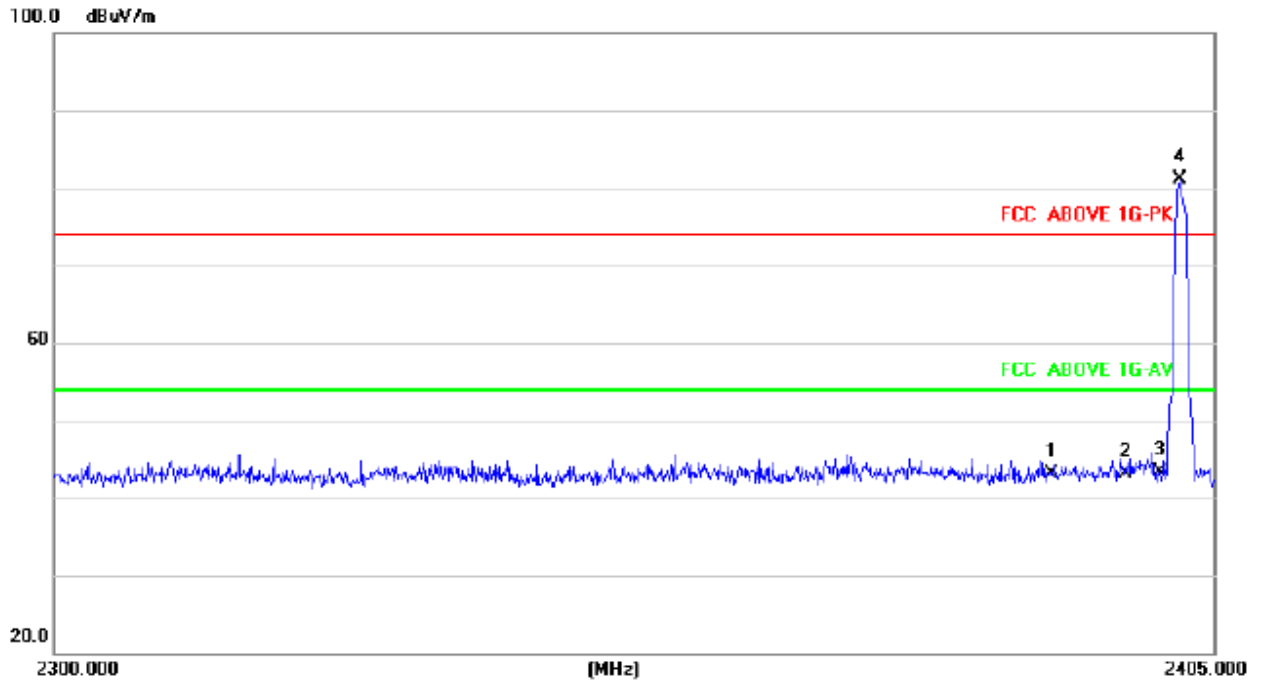



6. ANTENNA REQUIREMENT

6.1 STANDARD REQUIREMENT

15.203 requirement: For intentional device, according to 15.203: an intentional radiator shall be designed to ensure that no antenna other than that furnished by the responsible party shall be used with the device.

6.2 EUT ANTENNA

The EUT antenna is internal antenna. It complies with the standard requirement.



7. EUT TEST PHOTO

Conducted Measurement Photos





Radiated Measurement Photos

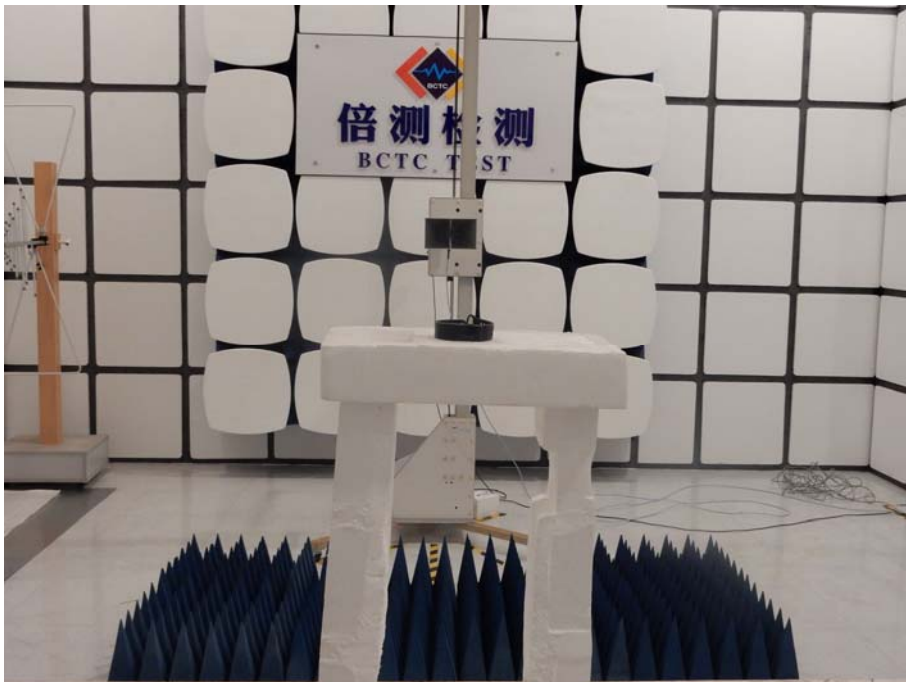

8. PHOTOS OF THE EUT







