



FCC Test Report

FCC ID: 2AHL5-ST907

Product: Industrial Tablet PC
Trade Name: SENTER
Model Number: ST907
Serial Model: N/A
Report No.: NTEK- 2016NT02014175F1

Prepared for

Shandong Senter Electronic Co.,Ltd.
No. 18, Liuyishan Road, New & Hi-tech Area, Zibo City,
Shandong Province, China

Prepared by

Shenzhen NTEK Testing Technology Co., Ltd.
1/F, Building E, Fenda Science Park, Sanwei Community, Xixiang Street,
Bao'an District, Shenzhen P.R. China
Tel.: +86-0755-61156588 Fax.: +86-0755-61156599
Website: www.ntek.org.cn

TEST RESULT CERTIFICATION

Applicant's name : Shandong Senter Electronic Co.,Ltd.
Address : No. 18, Liuyishan Road, New & Hi-tech Area, Zibo City,
Shandong Province, China
Manufacturer's Name : Shandong Senter Electronic Co.,Ltd.
Address : No. 18, Liuyishan Road, New & Hi-tech Area, Zibo City,
Shandong Province, China

Product description

Product name : Industrial Tablet PC
Model and/or type reference : ST907
FCC Part15B:01 Oct.2015
Standards : ANSI C63.4:2014

This device described above has been tested by NTEK, and the test results show that the equipment under test (EUT) is in compliance with Part 15 of FCC Rules. And it is applicable only to the tested sample identified in the report.

This report shall not be reproduced except in full, without the written approval of NTEK, this document may be altered or revised by NTEK, personnel only, and shall be noted in the revision of the document.

Date of Test :
Date (s) of performance of tests : 01 Feb. 2016 ~09 Mar. 2016
Date of Issue..... : 09 Mar. 2016
Test Result..... : **Pass**

Testing Engineer : Eileen Liu.
(Eileen Liu)

Technical Manager : Jason chen
(Jason Chen)

Authorized Signatory : Sam. chen
(Sam Chen)

| Table of Contents | Page |
|--|-------------|
| 1 . TEST SUMMARY | 4 |
| 1.1 TEST FACILITY | 5 |
| 1.2 MEASUREMENT UNCERTAINTY | 5 |
| 2 . GENERAL INFORMATION | 6 |
| 2.1 GENERAL DESCRIPTION OF EUT | 6 |
| 2.2 DESCRIPTION OF TEST SETUP | 8 |
| 2.3 DESCRIPTION TEST PERIPHERAL AND EUT PERIPHERAL | 9 |
| 2.4 MEASUREMENT INSTRUMENTS LIST | 10 |
| 3 . EMC EMISSION TEST | 11 |
| 3.1 CONDUCTED EMISSION MEASUREMENT | 11 |
| 3.1.1 POWER LINE CONDUCTED EMISSION | 11 |
| 3.1.2 TEST PROCEDURE | 12 |
| 3.1.3 TEST SETUP | 12 |
| 3.1.4 EUT OPERATING CONDITIONS | 12 |
| 3.1.5 TEST RESULTS | 13 |
| 3.2 RADIATED EMISSION MEASUREMENT | 17 |
| 3.2.1 LIMITS OF RADIATED EMISSION MEASUREMENT | 17 |
| 3.2.2 TEST PROCEDURE | 17 |
| 3.2.3 TEST SETUP | 18 |
| 3.2.4 TEST RESULTS | 19 |
| 3.2.5 TEST RESULTS(1000~12400MHz) | 21 |
| 4 . EUT TEST PHOTO | 22 |

1. TEST SUMMARY

Test procedures according to the technical standards:

| EMC Emission | | | | |
|--------------------------------------|--------------------|---------|----------|--------|
| Standard | Test Item | Limit | Judgment | Remark |
| FCC Part15B:2014 ANSI C63.4: 2014 | Conducted Emission | Class B | PASS | |
| | Radiated Emission | Class B | PASS | |

NOTE:

- (1) 'N/A' denotes test is not applicable in this Test Report
- (2) For client's request and manual description, the test will not be executed.

1.1 TEST FACILITY

NTEK Testing Technology Co., Ltd

Add. : 1/F, Building E, Fenda Science Park, Sanwei Community, Xixiang Street, Bao'an District, Shenzhen P.R. China.

FCC Registration Number:238937; IC Registration Number:9270A-1

CNAS Registration Number:L5516

1.2 MEASUREMENT UNCERTAINTY

The reported uncertainty of measurement $y \pm U$, where expanded uncertainty U is based on a standard uncertainty multiplied by a coverage factor of $k=2$, providing a level of confidence of approximately **95** %.

A. Conducted Measurement :

| Test Site | Method | Measurement Frequency Range | U, (dB) | NOTE |
|-----------|--------|-----------------------------|---------|------|
| NTEKC01 | ANSI | 150 KHz ~ 30MHz | 3.2 | |

B. Radiated Measurement :

| Test Site | Method | Measurement Frequency Range | U, (dB) | NOTE |
|-----------|--------|-----------------------------|---------|------|
| NTEKA01 | ANSI | 30MHz ~ 1000MHz | 4.7 | |
| | | 1GHz ~12.4GHz | 5.0 | |

2. GENERAL INFORMATION

2.1 GENERAL DESCRIPTION OF EUT

| | | |
|---------------------|--|--|
| Equipment | Industrial Tablet PC | |
| Trade Name | SENER | |
| Model Name | ST907 | |
| Serial Model | N/A | |
| Model Difference | N/A | |
| Product Description | The EUT is a Industrial Tablet PC. | |
| | Connecting I/O port: | USB, DC in |
| | Operation Frequency: | BT:2402~2480 MHz WIFI:802.11b/g/n(20MHz): 2412~2462MHz 802.11n(40MHz):2422~2452MHz GSM: 824.2-848.8MHz/1850.2-1909.8MHz WCDMA: 826.4-846.6MHz/ 1852.4-1907.6MHz |
| Modulation Type: | BT(1Mbps): GFSK BT EDR(2Mbps): $\pi/4$ -DQPSK BT EDR(3Mbps): 8-DPSK IEEE 802.11b : DSSS (CCK, QPSK, DBPSK) IEEE 802.11g/n (HT20/HT40) : OFDM (64QAM, 16QAM, QPSK, BPSK) GSM / DCS: GMSK WCDMA:QPSK | |
| Power Source | DC Voltage | |
| Adapter | Model: P12050200 Input: 100-240V~, 50/60Hz, 0.3A Output: 5.0V ---, 2.0A | |
| Battery | DC 3.7V, 7200mAh | |

2.1.1 DESCRIPTION OF TEST MODES

To investigate the maximum EMI emission characteristics generates from EUT, the test system was pre-scanning tested base on the consideration of following EUT operation mode or test configuration mode which possible have effect on EMI emission level. Each of these EUT operation mode(s) or test configuration mode(s) mentioned above was evaluated respectively.

| Pretest Mode | Description |
|--------------|---------------|
| Mode 1 | Connect to PC |
| Mode 2 | Camera |
| Mode 3 | TF card Play |
| Mode 4 | "H" Pattern |

| For Conducted Test | |
|--------------------|---------------|
| Final Test Mode | Description |
| Mode 1 | Connect to PC |
| Mode 2 | Camera |
| Mode 3 | TF card Play |
| Mode 4 | "H" Pattern |

| For Radiated Test | |
|-------------------|---------------|
| Final Test Mode | Description |
| Mode 1 | Connect to PC |
| Mode 2 | Camera |
| Mode 3 | TF card Play |
| Mode 4 | "H" Pattern |

Note: Final Test Mode: Through Pre-scan, find the mode 1 is the worst case. Only the worst case mode is recorded in the report.

2.2 DESCRIPTION OF TEST SETUP

RE

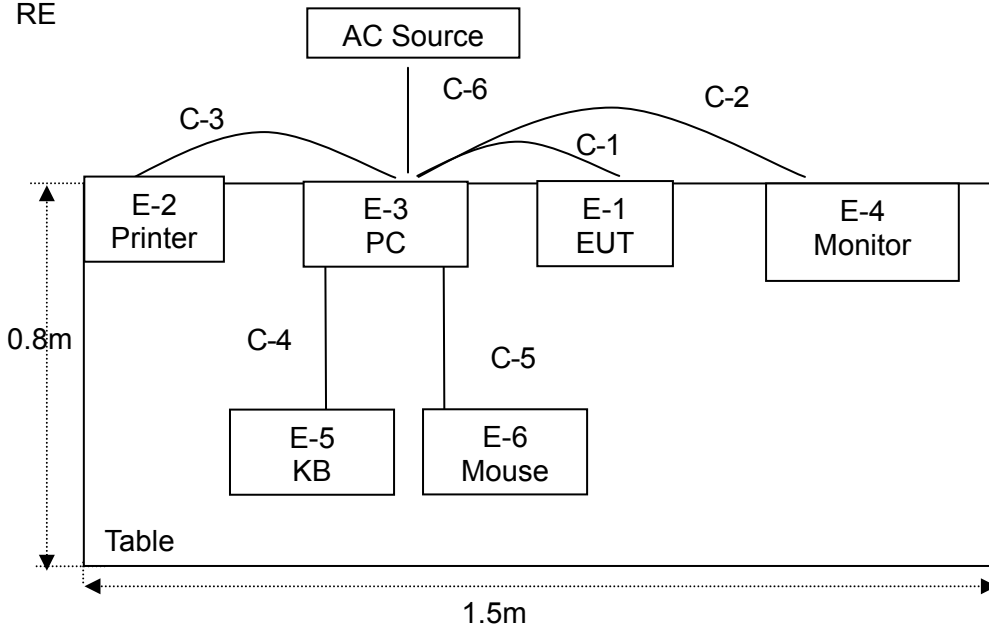

CE

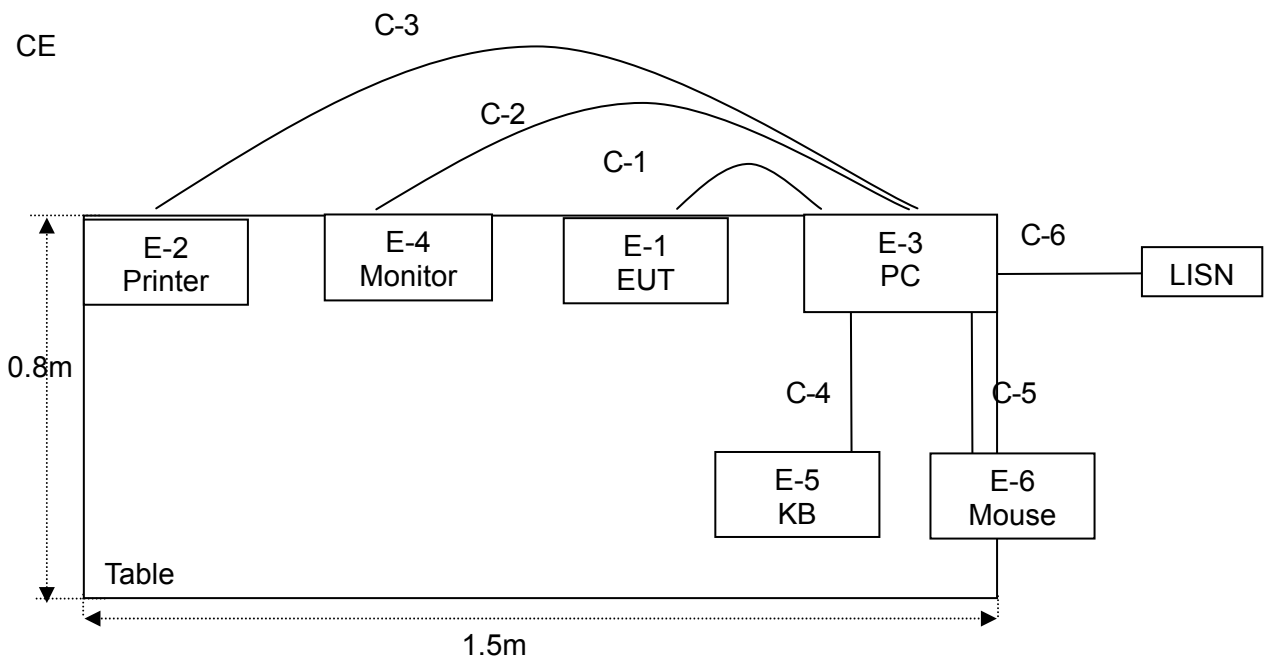

2.3 DESCRIPTION TEST PERIPHERAL AND EUT PERIPHERAL

The EUT has been tested as an independent unit together with other necessary accessories or support units. The following support units or accessories were used to form a representative test configuration during the tests.

| Item | Equipment | Brand | Model/Type No. | Series No. | Note |
|------|----------------------|---------|----------------|--------------------------|------|
| E-1 | Industrial Tablet PC | SEENTER | ST907 | N/A | EUT |
| E-2 | Printer | Canon | L11121E | LBP2900 | |
| E-3 | Personal computer | DELL | FT4Y23X | 34413561645 | |
| E-4 | Monitor | DELL | IN2020MB | cn-0y6mhx-74261-11f-67es | |
| E-5 | Keyboard | DELL | SK-8185 | OY526KUS | |
| E-6 | Mouse | DELL | MS111-P | cn-011d3v-71581-11e-1th7 | |
| | | | | | |
| | | | | | |
| | | | | | |
| | | | | | |

| Item | Cable Type | Shielded Type | Ferrite Core | Length | Note |
|------|------------|---------------|--------------|--------|------|
| C-1 | USB Cable | NO | NO | 1.2m | |
| C-2 | VGA | NO | NO | 1.0m | |
| C-3 | USB Cable | NO | NO | 1.2m | |
| C-4 | USB Cable | NO | NO | 1.0m | |
| C-5 | USB Cable | NO | NO | 1.0m | |
| C-6 | Power Line | NO | NO | 1.2m | |
| | | | | | |
| | | | | | |

Note:

- (1) The support equipment was authorized by Declaration of Confirmation.
- (2) For detachable type I/O cable should be specified the length in cm in 『Length』 column.
- (3) “YES” means “shielded” “with core”; “NO” means “unshielded” “without core”.

2.4 MEASUREMENT INSTRUMENTS LIST

Radiation Test equipment

| Item | Kind of Equipment | Manufacturer | Type No. | Serial No. | Last calibration | Calibrated until | Calibration period |
|------|--------------------|--------------|-------------|--------------|------------------|------------------|--------------------|
| 1 | Spectrum Analyzer | Agilent | E4407B | MY45108040 | 2015.07.06 | 2016.07.05 | 1 year |
| 2 | Test Receiver | R&S | ESPI | 101318 | 2015.06.07 | 2016.06.06 | 1 year |
| 3 | Bilog Antenna | TESEQ | CBL6111D | 31216 | 2015.07.06 | 2016.07.05 | 1 year |
| 4 | 50Ω Coaxial Switch | Anritsu | MP59B | 6200264416 | 2015.06.07 | 2016.06.06 | 1 year |
| 5 | Spectrum Analyzer | ADVANTEST | R3132 | 150900201 | 2015.06.07 | 2016.06.06 | 1 year |
| 6 | Horn Antenna | EM | EM-AH-10180 | 2011071402 | 2015.07.06 | 2016.07.05 | 1 year |
| 7 | Horn Ant | Schwarzbeck | BBHA 9170 | 9170-181 | 2015.07.06 | 2016.07.05 | 1 year |
| 8 | Amplifier | EM | EM-30180 | 060538 | 2015.07.06 | 2016.07.05 | 1 year |
| 9 | Loop Antenna | ARA | PLA-1030/B | 1029 | 2015.06.08 | 2016.06.07 | 1 year |
| 10 | Power Meter | R&S | NRVS | 100696 | 2015.07.06 | 2016.07.05 | 1 year |
| 11 | Power Sensor | R&S | URV5-Z4 | 0395.1619.05 | 2015.07.06 | 2016.07.05 | 1 year |
| 12 | Test Cable | N/A | R-01 | N/A | 2015.07.06 | 2016.07.05 | 1 year |
| 13 | Test Cable | N/A | R-02 | N/A | 2015.07.06 | 2016.07.05 | 1 year |

Conduction Test equipment

| Item | Kind of Equipment | Manufacturer | Type No. | Serial No. | Last calibration | Calibrated until | Calibration period |
|------|-----------------------|--------------|----------|------------|------------------|------------------|--------------------|
| 1 | Test Receiver | R&S | ESCI | 101160 | 2015.06.06 | 2016.06.05 | 1 year |
| 2 | LISN | R&S | ENV216 | 101313 | 2015.08.24 | 2016.08.23 | 1 year |
| 3 | LISN | EMCO | 3816/2 | 00042990 | 2015.08.24 | 2016.08.23 | 1 year |
| 4 | 50Ω Coaxial Switch | Anritsu | MP59B | 6200264417 | 2015.06.07 | 2016.06.06 | 1 year |
| 5 | Passive Voltage Probe | R&S | ESH2-Z3 | 100196 | 2015.06.07 | 2016.06.06 | 1 year |
| 6 | Absorbing clamp | R&S | MOS-21 | 100423 | 2015.06.08 | 2016.06.07 | 1 year |
| 7 | Test Cable | N/A | C01 | N/A | 2015.06.08 | 2016.06.07 | 1 year |
| 8 | Test Cable | N/A | C02 | N/A | 2015.06.08 | 2016.06.07 | 1 year |
| 9 | Test Cable | N/A | C03 | N/A | 2015.06.08 | 2016.06.07 | 1 year |

3. EMC EMISSION TEST

3.1 CONDUCTED EMISSION MEASUREMENT

3.1.1 POWER LINE CONDUCTED EMISSION (Frequency Range 150KHz-30MHz)

| FREQUENCY (MHz) | Class A (dBuV) | | Class B (dBuV) | |
|-----------------|----------------|---------|----------------|-----------|
| | Quasi-peak | Average | Quasi-peak | Average |
| 0.15 -0.5 | 79.00 | 66.00 | 66 - 56 * | 56 - 46 * |
| 0.50 -5.0 | 73.00 | 60.00 | 56.00 | 46.00 |
| 5.0 -30.0 | 73.00 | 60.00 | 60.00 | 50.00 |

Note:

- (1) The tighter limit applies at the band edges.
- (2) The limit of " * " marked band means the limitation decreases linearly with the logarithm of the frequency in the range.

The following table is the setting of the receiver

| Receiver Parameters | Setting |
|---------------------|----------|
| Attenuation | 10 dB |
| Start Frequency | 0.15 MHz |
| Stop Frequency | 30 MHz |
| IF Bandwidth | 9 kHz |

3.1.2 TEST PROCEDURE

- a. The EUT was placed 0.8 meters from the horizontal ground plane with EUT being connected to the power mains through a line impedance stabilization network (LISN). All other support equipments powered from additional LISN(s). The LISN provide 50 Ohm/ 50uH of coupling impedance for the measuring instrument.
- b. Interconnecting cables that hang closer than 40 cm to the ground plane shall be folded back and forth in the center forming a bundle 30 to 40 cm long.
- c. I/O cables that are not connected to a peripheral shall be bundled in the center. The end of the cable may be terminated, if required, using the correct terminating impedance. The overall length shall not exceed 1 m.
- d. LISN at least 80 cm from nearest part of EUT chassis.
- e. For the actual test configuration, please refer to the related Item –EUT Test Photos.

3.1.3 TEST SETUP

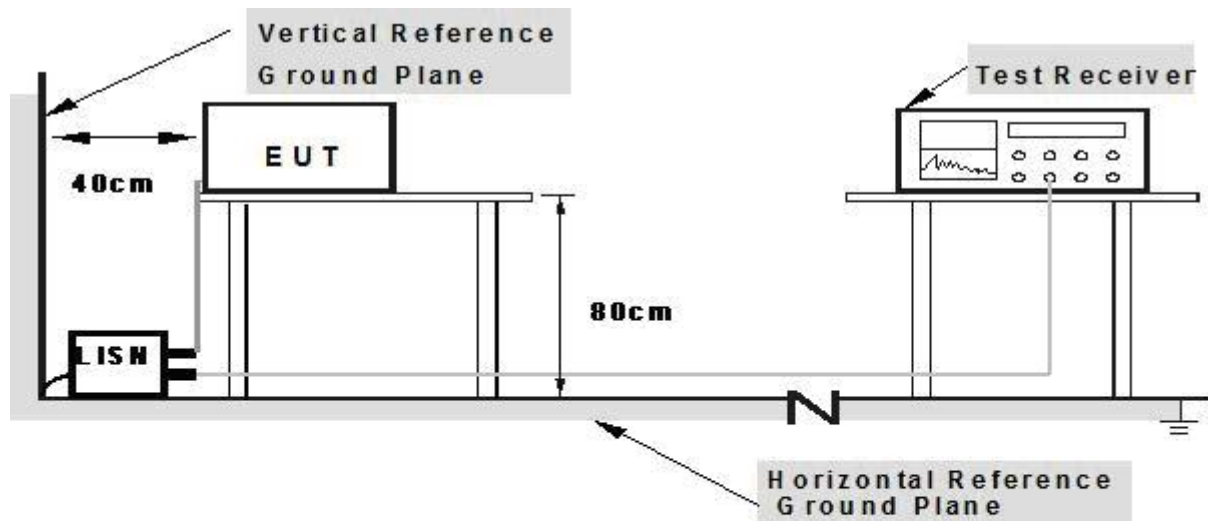

Note: 1. Support units were connected to second LISN.

2. Both of LISNs (AMN) are 80 cm from EUT and at least 80 cm from other units and other metal planes

3.1.4 EUT OPERATING CONDITIONS

The EUT tested system was configured as the statements of 2.3 Unless otherwise a special operating condition is specified in the follows during the testing.

3.1.5 TEST RESULTS

| | | | |
|---------------|----------------------------|--------------------|-----------|
| EUT: | Industrial Tablet PC | Model Name. : | ST907 |
| Temperature: | 26 °C | Relative Humidity: | 54% |
| Pressure: | 1010hPa | Test Date: | 2016-2-23 |
| Test Mode: | Mode 1 | Phase : | L |
| Test Voltage: | DC 5V From PC AC 120V/60Hz | | |

| Frequency (MHz) | Reading Level (dBμV) | Correct Factor (dB) | Measure-ment (dBμV) | Limits (dBμV) | Margin (dB) | Remark |
|-----------------|----------------------|---------------------|---------------------|---------------|-------------|--------|
| 0.2020 | 31.27 | 10.28 | 41.55 | 63.52 | -21.97 | QP |
| 0.5020 | 29.22 | 10.02 | 39.24 | 56.00 | -16.76 | AVG |
| 1.1020 | 25.12 | 10.00 | 35.12 | 56.00 | -20.88 | QP |
| 7.0779 | 35.23 | 9.88 | 45.11 | 60.00 | -14.89 | AVG |
| 25.0660 | 33.41 | 10.18 | 43.59 | 60.00 | -16.41 | QP |
| 16.1419 | 31.85 | 10.02 | 41.87 | 60.00 | -18.13 | AVG |
| 0.1980 | 28.03 | 10.28 | 38.31 | 53.69 | -15.38 | QP |
| 0.4020 | 23.52 | 10.24 | 33.76 | 47.81 | -14.05 | AVG |
| 24.9620 | 27.97 | 10.18 | 38.15 | 50.00 | -11.85 | QP |
| 16.2379 | 24.72 | 10.02 | 34.74 | 50.00 | -15.26 | AVG |

Remark:

1. All readings are Quasi-Peak and Average values.
2. Factor = Insertion Loss + Cable Loss.

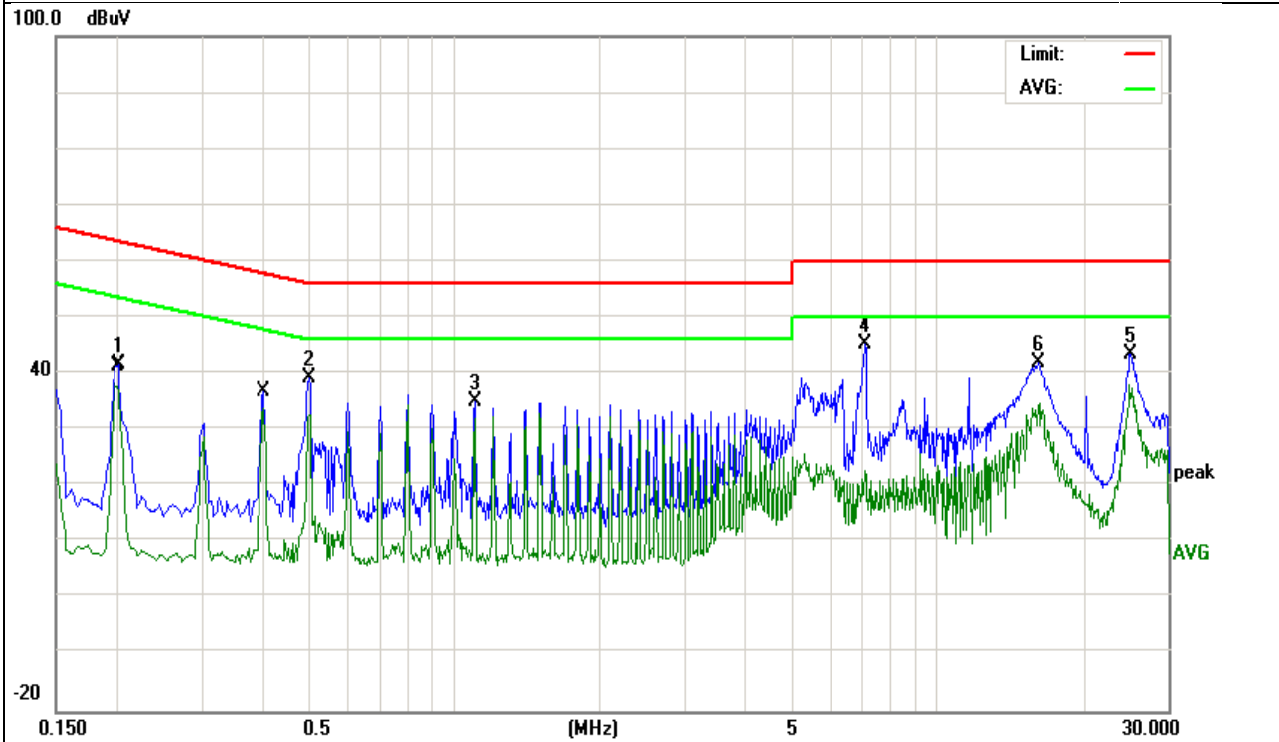

| | | | |
|---------------|----------------------------|--------------------|-----------|
| EUT: | Industrial Tablet PC | Model Name. : | ST907 |
| Temperature: | 26 °C | Relative Humidity: | 54% |
| Pressure: | 1010hPa | Test Date: | 2016-2-23 |
| Test Mode: | Mode 1 | Phase : | N |
| Test Voltage: | DC 5V From PC AC 120V/60Hz | | |

| Frequency (MHz) | Reading Level (dBμV) | Correct Factor (dB) | Measure-ment (dBμV) | Limits (dBμV) | Margin (dB) | Remark |
|-----------------|----------------------|---------------------|---------------------|---------------|-------------|--------|
| 0.2020 | 33.82 | 10.17 | 43.99 | 63.52 | -19.53 | QP |
| 0.8020 | 26.60 | 10.03 | 36.63 | 56.00 | -19.37 | AVG |
| 1.5060 | 24.96 | 9.94 | 34.90 | 56.00 | -21.10 | QP |
| 7.2419 | 37.20 | 9.85 | 47.05 | 60.00 | -12.95 | AVG |
| 25.1660 | 33.91 | 10.17 | 44.08 | 60.00 | -15.92 | QP |
| 0.2020 | 29.55 | 10.17 | 39.72 | 53.52 | -13.80 | AVG |
| 0.8020 | 24.53 | 10.03 | 34.56 | 46.00 | -11.44 | QP |
| 25.1660 | 27.92 | 10.17 | 38.09 | 50.00 | -11.91 | AVG |

Remark:

1. All readings are Quasi-Peak and Average values.
2. Factor = Insertion Loss + Cable Loss.

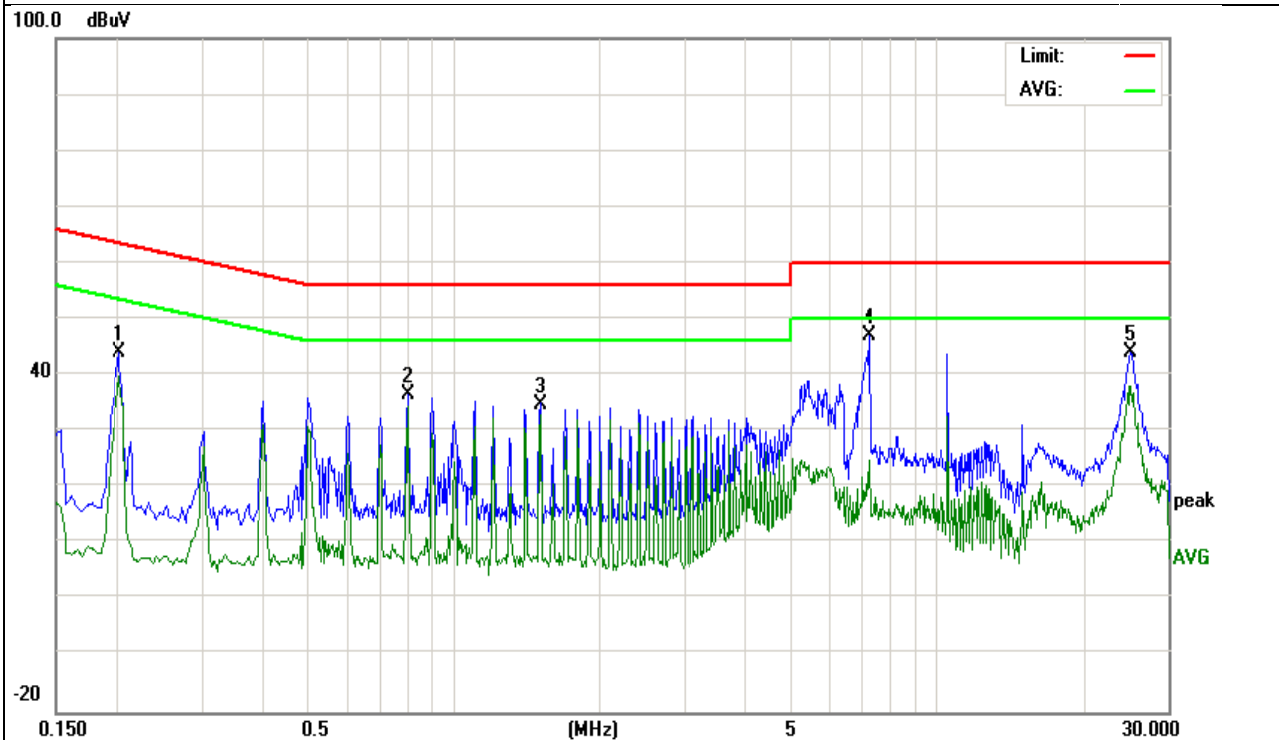

| | | | |
|---------------|----------------------------|--------------------|-----------|
| EUT: | Industrial Tablet PC | Model Name. : | ST907 |
| Temperature: | 26 °C | Relative Humidity: | 54% |
| Pressure: | 1010hPa | Test Date: | 2016-2-23 |
| Test Mode: | Mode 1 | Phase : | L |
| Test Voltage: | DC 5V From PC AC 240V/60Hz | | |

| Frequency (MHz) | Reading Level (dBμV) | Correct Factor (dB) | Measure-ment (dBμV) | Limits (dBμV) | Margin (dB) | Remark |
|-----------------|----------------------|---------------------|---------------------|---------------|-------------|--------|
| 0.2020 | 25.87 | 10.28 | 36.15 | 63.52 | -27.37 | QP |
| 0.5020 | 29.43 | 10.02 | 39.45 | 56.00 | -16.55 | AVG |
| 7.3739 | 38.14 | 9.88 | 48.02 | 60.00 | -11.98 | QP |
| 16.0619 | 31.48 | 10.02 | 41.50 | 60.00 | -18.50 | AVG |
| 25.1900 | 34.24 | 10.18 | 44.42 | 60.00 | -15.58 | QP |
| 1.4060 | 25.46 | 9.94 | 35.40 | 56.00 | -20.60 | AVG |
| 0.5020 | 24.26 | 10.02 | 34.28 | 46.00 | -11.72 | QP |
| 1.4060 | 23.75 | 9.94 | 33.69 | 46.00 | -12.31 | AVG |
| 15.8579 | 23.67 | 10.01 | 33.68 | 50.00 | -16.32 | QP |
| 25.3900 | 27.45 | 10.18 | 37.63 | 50.00 | -12.37 | AVG |

Remark:

1. All readings are Quasi-Peak and Average values.
2. Factor = Insertion Loss + Cable Loss.

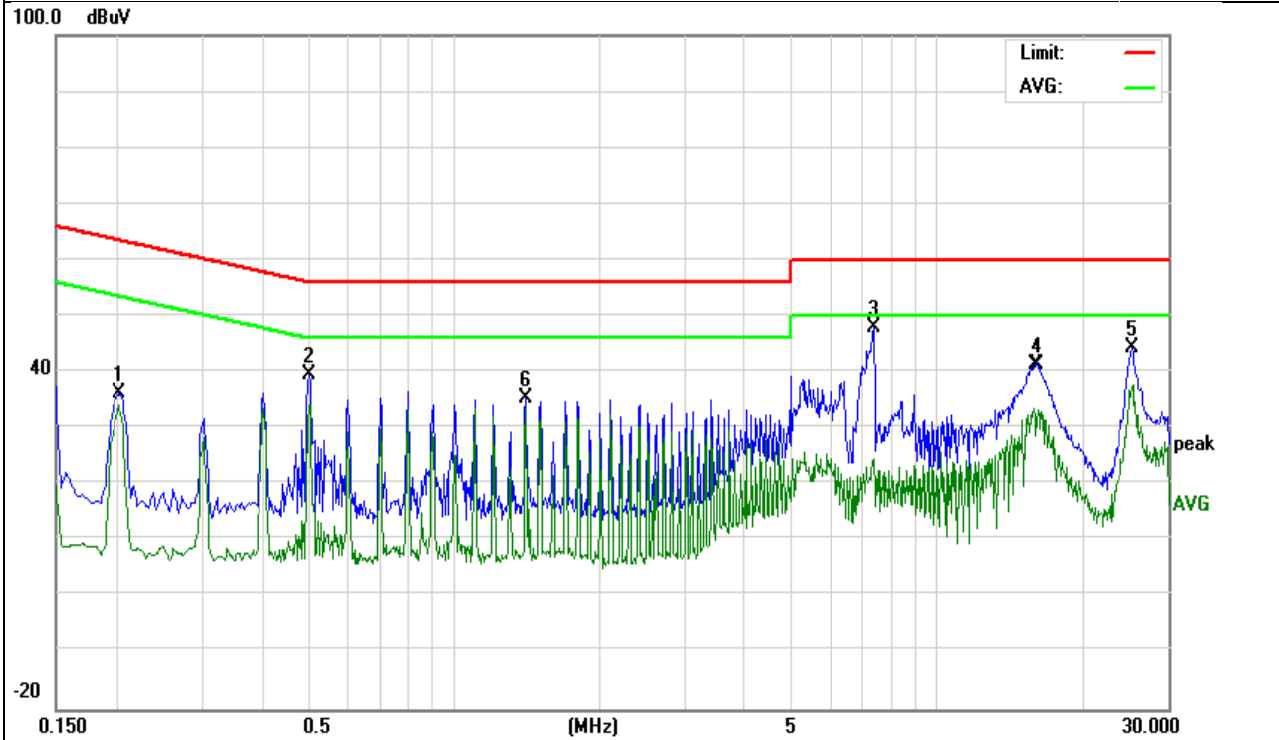

| | | | |
|---------------|----------------------------|--------------------|-----------|
| EUT: | Industrial Tablet PC | Model Name. : | ST907 |
| Temperature: | 26 °C | Relative Humidity: | 54% |
| Pressure: | 1010hPa | Test Date: | 2016-2-23 |
| Test Mode: | Mode 1 | Phase : | N |
| Test Voltage: | DC 5V From PC AC 240V/60Hz | | |

| Frequency (MHz) | Reading Level (dBμV) | Correct Factor (dB) | Measure-ment (dBμV) | Limits (dBμV) | Margin (dB) | Remark |
|-----------------|----------------------|---------------------|---------------------|---------------|-------------|--------|
| 0.2020 | 33.50 | 10.17 | 43.67 | 63.52 | -19.85 | QP |
| 0.5020 | 27.34 | 10.04 | 37.38 | 56.00 | -18.62 | AVG |
| 1.1020 | 25.41 | 10.02 | 35.43 | 56.00 | -20.57 | QP |
| 7.2659 | 36.48 | 9.85 | 46.33 | 60.00 | -13.67 | AVG |
| 25.1740 | 34.58 | 10.17 | 44.75 | 60.00 | -15.25 | QP |
| 9.3939 | 36.31 | 9.88 | 46.19 | 60.00 | -13.81 | AVG |
| 0.2020 | 30.66 | 10.17 | 40.83 | 53.52 | -12.69 | QP |
| 0.8020 | 23.42 | 10.03 | 33.45 | 46.00 | -12.55 | AVG |
| 25.1740 | 27.32 | 10.17 | 37.49 | 50.00 | -12.51 | QP |

Remark:

1. All readings are Quasi-Peak and Average values.
2. Factor = Insertion Loss + Cable Loss.

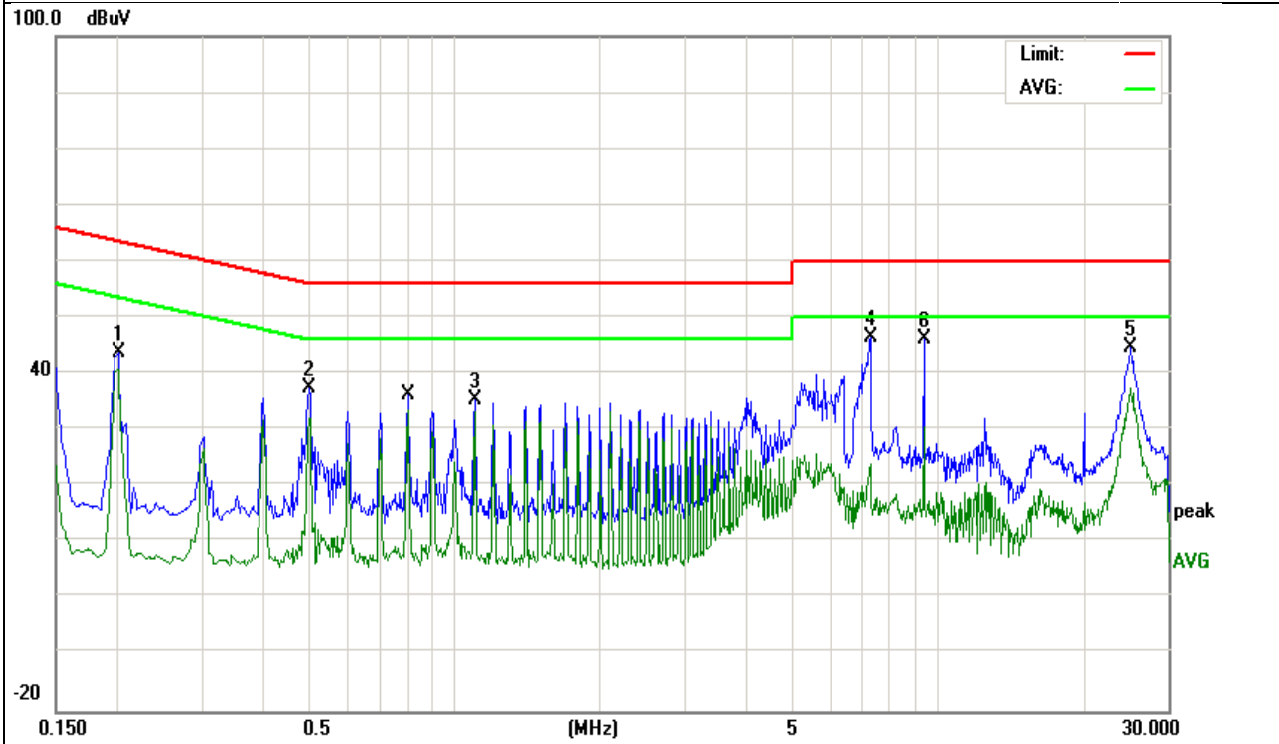

3.2 RADIATED EMISSION MEASUREMENT

3.2.1 LIMITS OF RADIATED EMISSION MEASUREMENT

| FREQUENCY (MHz) | Class A (at 10m) | Class B (at 3m) |
|-----------------|------------------|-----------------|
| | dBuV/m | dBuV/m |
| 30 ~ 88 | 39.0 | 40.0 |
| 88 ~ 216 | 43.5 | 43.5 |
| 216 ~ 960 | 46.5 | 46.0 |
| Above 960 | 49.5 | 54.0 |

Notes:

- (1) The limit for radiated test was performed according to as following:
FCC PART 15B /ICES-003.
- (2) The tighter limit applies at the band edges.
- (3) Emission level (dBuV/m)=20log Emission level (uV/m).

3.2.2 TEST PROCEDURE

Test Arrangement for Radiated Emissions up to 1 GHz

- a. The EUT was placed on the top of a rotating table 0.8 meters above the ground at an accredited test facility. The table was rotated 360 degrees to determine the position of the highest radiation.
- b. The EUT was set 3 meters away from the interference-receiving antenna, which was mounted on the top of a variable-height antenna tower.
- c. The antenna is a broadband antenna, and its height is varied from one meter to four meters above the ground to determine the maximum value of the field strength. Both horizontal and vertical polarizations of the antenna are set to make the measurement.
- d. For each suspected emission, the EUT was arranged to its worst case and then the antenna was tuned to heights from 1 meter to 4 meters and the rotatable table was turned from 0 degrees to 360 degrees to find the maximum reading.

Note: The resolution bandwidth and video bandwidth of test receiver/spectrum analyzer is 120kHz for quasi-peak detection (QP) at frequency below 1GHz.

Test Arrangement for Radiated Emissions above 1 GHz.

- a. The EUT was placed on the top of a rotating table 0.8 meters above the ground at an accredited chamber room. The table was rotated 360 degrees to determine the position of the highest radiation.
- b. The EUT was set 3 meters away from the interference-receiving antenna, which was mounted on the top of a variable-height antenna tower.
- c. The height of antenna can be varied from one meter to four meters, the height of adjustment depends on the EUT height and the antenna 3dB beamwidth both, to detect the maximum value of the field strength.Both horizontal and vertical polarizations of the antenna are set to make the measurement.
- d. For each suspected emission, the EUT was arranged to its worst case and then the antenna was tuned to heights and the rotatable table was turned from 0 degrees to 360 degrees to find the maximum reading.

Note: For the hand-held device, the EUT should be measured for all 3 axes and only the worst case is recorded in the report

During the radiated emission test, the Spectrum Analyzer was set with the following configurations:

| Frequency Band (MHz) | Function | Resolution bandwidth | Video Bandwidth |
|----------------------|----------|----------------------|-----------------|
| 30 to 1000 | QP | 120 kHz | 300 kHz |
| Above 1000 | Peak | 1 MHz | 1 MHz |
| | Avg | 1 MHz | 10 Hz |

3.2.3 TEST SETUP

For Radiated Emission 30~1000MHz

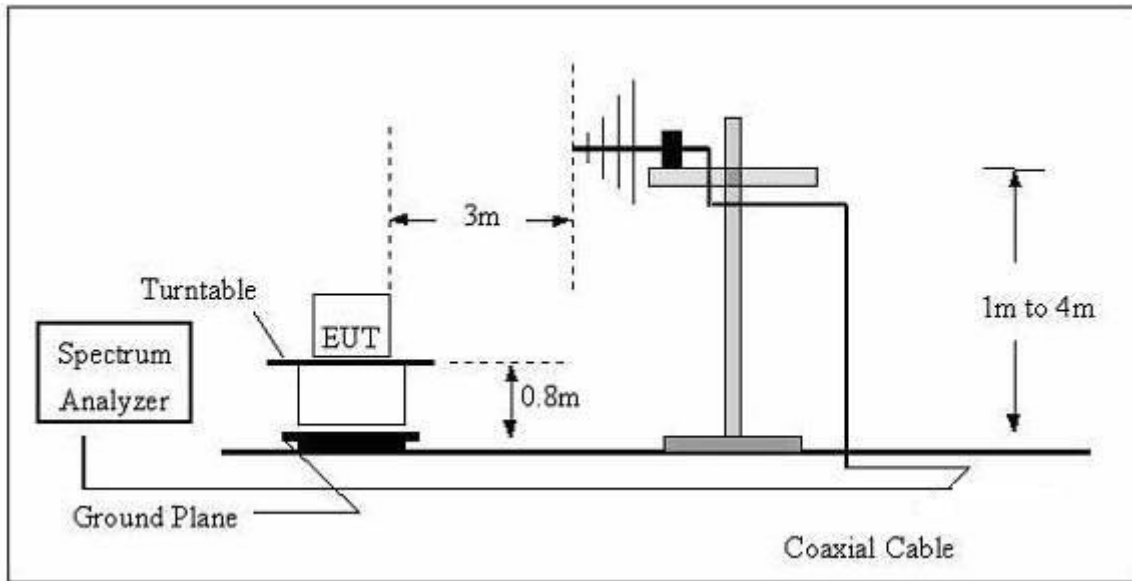

(B) Radiated Emission Test Set-Up Frequency Above 1GHz

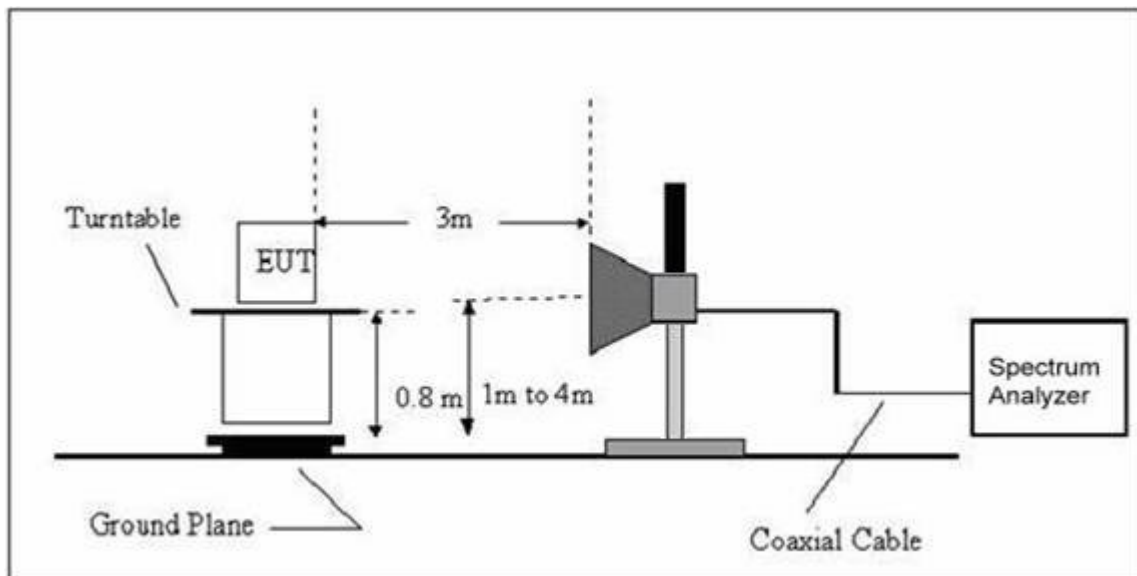

3.2.4 TEST RESULTS

TEST RESULTS (30~1000 MHz)

| | | | |
|--------------|----------------------------|--------------------|------------|
| EUT: | Industrial Tablet PC | Model Name: | ST907 |
| Temperature: | 24 °C | Relative Humidity: | 54% |
| Pressure: | 1010 hPa | Test Date : | 2016-2-23 |
| Test Mode : | Mode 1 | Polarization : | Horizontal |
| Test Power : | DC 5V From PC AC 120V/60Hz | | |

| Polar (H/V) | Frequency | Meter Reading | Factor | Emission Level | Limits | Margin | Remark |
|-------------|-----------|---------------|--------|----------------|----------|--------|--------|
| | (MHz) | (dBuV) | (dB) | (dBuV/m) | (dBuV/m) | (dB) | |
| H | 228.4904 | 19.61 | 10.85 | 30.46 | 46.00 | -15.54 | QP |
| H | 163.1818 | 15.34 | 11.63 | 26.97 | 43.50 | -16.53 | QP |
| H | 133.6188 | 13.45 | 10.95 | 24.40 | 43.50 | -19.10 | QP |

Remark:
Factor = Antenna Factor + Cable Loss - Amplifier.

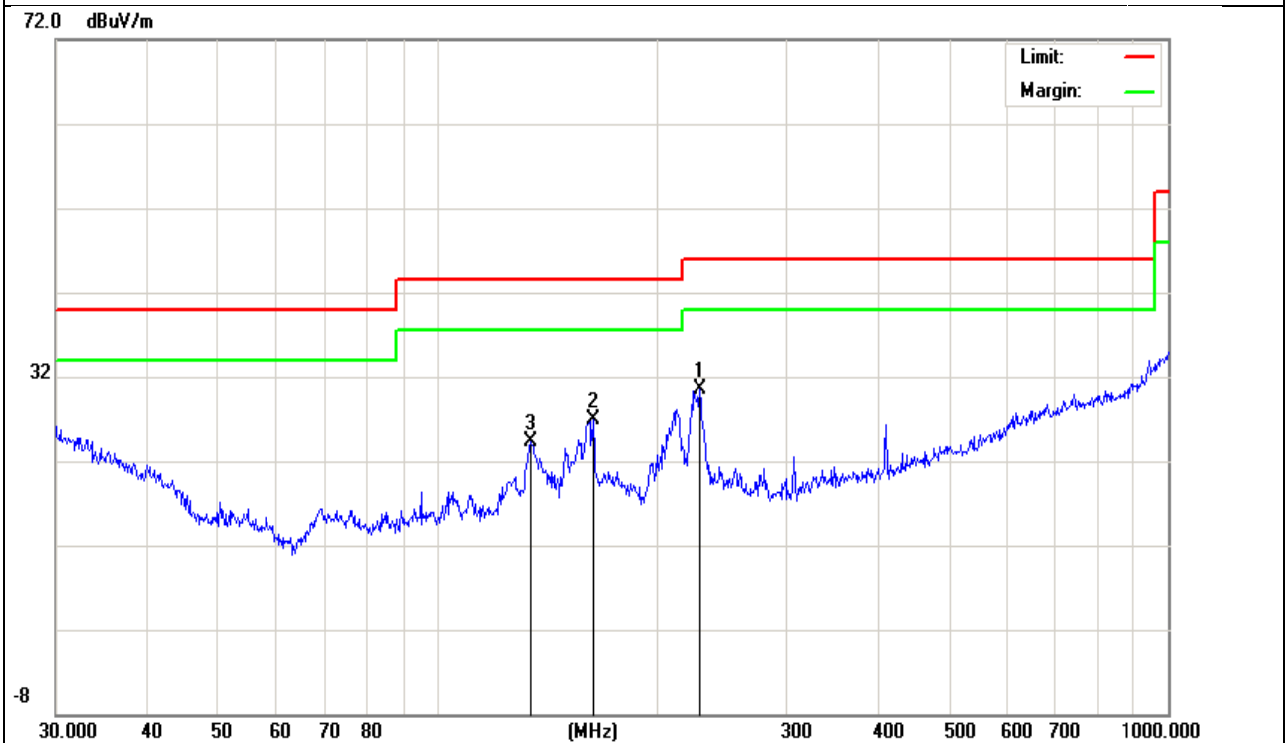

| | | | |
|--------------|----------------------------|--------------------|-----------|
| EUT: | Industrial Tablet PC | Model Name : | ST907 |
| Temperature: | 24 °C | Relative Humidity: | 54% |
| Pressure: | 1010 hPa | Test Date : | 2016-2-23 |
| Test Mode : | Mode 1 | Polarization : | Vertical |
| Test Power : | DC 5V From PC AC 120V/60Hz | | |

| Polar (H/V) | Frequency | Meter Reading | Factor | Emission Level | Limits | Margin | Remark |
|-------------|-----------|---------------|--------|----------------|----------|--------|--------|
| | (MHz) | (dBuV) | (dB) | (dBuV/m) | (dBuV/m) | (dB) | |
| V | 127.2176 | 27.26 | 10.76 | 38.02 | 43.50 | -5.48 | QP |
| V | 204.9550 | 19.73 | 11.57 | 31.30 | 43.50 | -12.20 | QP |
| V | 332.5187 | 16.36 | 13.72 | 30.08 | 46.00 | -15.92 | QP |
| V | 42.7496 | 15.99 | 13.16 | 29.15 | 40.00 | -10.85 | QP |
| V | 665.8034 | 20.69 | 20.77 | 41.46 | 46.00 | -4.54 | QP |

Remark:

Factor = Antenna Factor + Cable Loss - Amplifier.

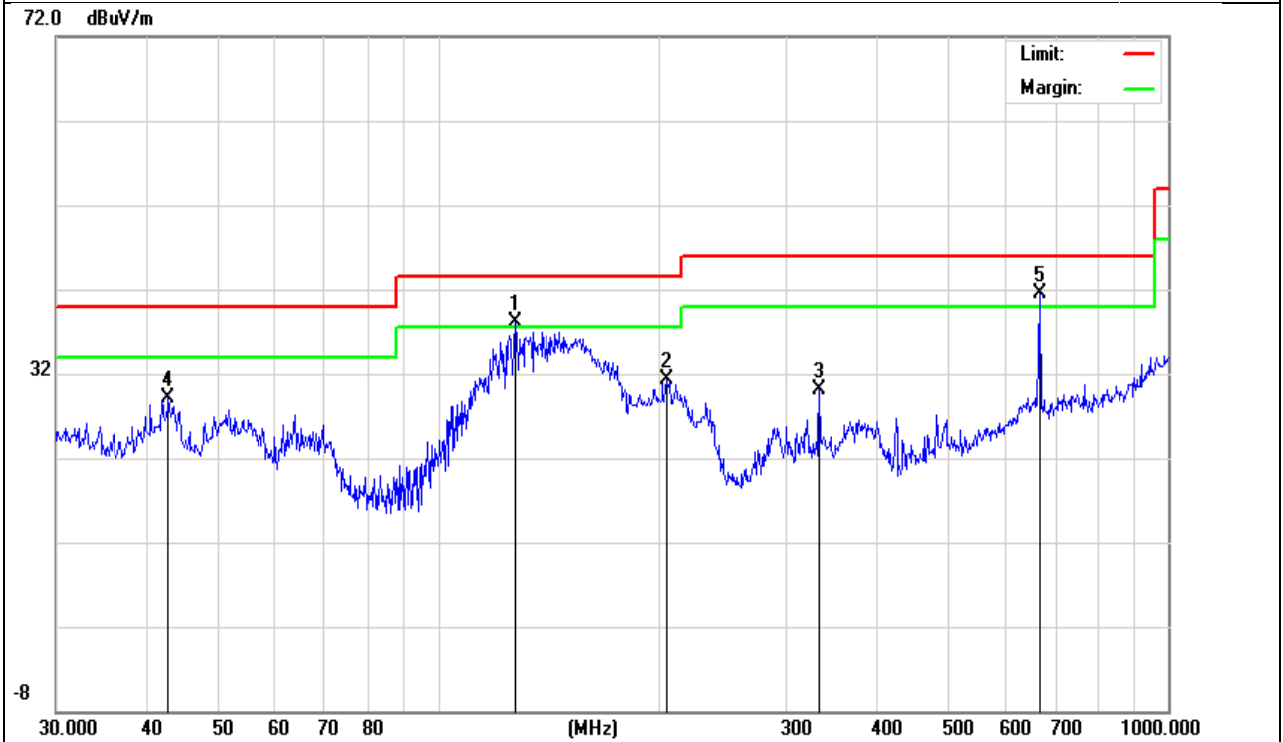

3.2.5 TEST RESULTS(1000~12400MHz)

| Polar (H/V) | Frequency | Meter Reading | Factor | Emission Level | Limits | Margin | Remark |
|----------------|-----------|------------------|--------|-------------------|----------|--------|--------|
| | (MHz) | (dBuV) | (dB) | (dBuV/m) | (dBuV/m) | (dB) | |
| V | 4821.884 | 48.08 | 1.34 | 49.42 | 74.00 | -24.58 | peak |
| V | 1493.846 | 49.75 | -12.49 | 37.26 | 74.00 | -36.74 | AVG |
| V | 2346.389 | 50.37 | -10.84 | 39.53 | 74.00 | -34.47 | peak |
| V | 3492.606 | 49.76 | -4.88 | 44.88 | 74.00 | -29.12 | AVG |
| H | 4865.277 | 47.18 | 1.52 | 48.70 | 74.00 | -25.30 | peak |
| H | 3555.749 | 50.47 | -4.66 | 45.81 | 74.00 | -28.19 | AVG |
| H | 4432.448 | 48.99 | -0.56 | 48.43 | 74.00 | -25.57 | peak |
| H | 1393.022 | 49.66 | -12.69 | 36.97 | 74.00 | -37.03 | AVG |
| H | 2160.753 | 49.81 | -10.90 | 38.91 | 74.00 | -35.09 | peak |

Remark:

Absolute Level= ReadingLevel+ Factor, Margin= Absolute Level - Limit

4. EUT TEST PHOTO

Radiated Measurement Photos

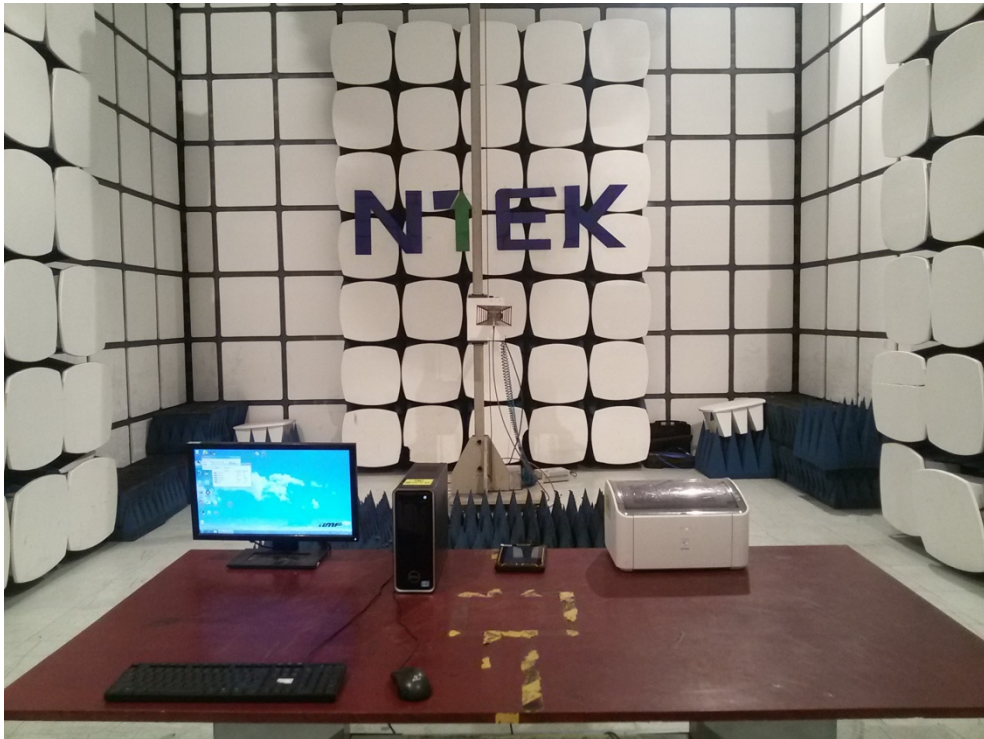

Conducted Measurement Photos

