

## FCC Test Report

**Report No.:** RF181001E06

**FCC ID:** 2AHKM-XM2

**Test Model:** XM2

**Received Date:** Oct. 01, 2018

**Test Date:** Nov. 01 to 06, 2018

**Issued Date:** Nov. 16, 2018

**Applicant:** Hitron Technologies Inc.

**Address:** No. 1-8, Li-Hsin 1st Rd., Hsinchu Science Park, HSINCHU, 30078, Taiwan

**Issued By:** Bureau Veritas Consumer Products Services (H.K.) Ltd., Taoyuan Branch  
Hsin Chu Laboratory

**Lab Address:** E-2, No.1, Li Hsin 1st Road, Hsinchu Science Park, Hsinchu City 300,  
Taiwan R.O.C.

**Test Location :** E-2, No.1, Li Hsin 1st Road, Hsinchu Science Park, Hsinchu City 300,  
Taiwan R.O.C.

**FCC Registration /  
Designation Number:** 723255 / TW2022



This report is for your exclusive use. Any copying or replication of this report to or for any other person or entity, or use of our name or trademark, is permitted only with our prior written permission. This report sets forth our findings solely with respect to the test samples identified herein. The results set forth in this report are not indicative or representative of the quality or characteristics of the lot from which a test sample was taken or any similar or identical product unless specifically and expressly noted. Our report includes all of the tests requested by you and the results thereof based upon the information that you provided to us. You have 60 days from date of issuance of this report to notify us of any material error or omission caused by our negligence, provided, however, that such notice shall be in writing and shall specifically address the issue you wish to raise. A failure to raise such issue within the prescribed time shall constitute your unqualified acceptance of the completeness of this report, the tests conducted and the correctness of the report contents. Unless specific mention, the uncertainty of measurement has been explicitly taken into account to declare the compliance or non-compliance to the specification. The report must not be used by the client to claim product certification, approval, or endorsement by TAF or any government agencies.

## Table of Contents

<b>Release Control Record</b> .....	<b>4</b>
<b>1 Certificate of Conformity</b> .....	<b>5</b>
<b>2 Summary of Test Results</b> .....	<b>6</b>
2.1 Measurement Uncertainty .....	6
2.2 Modification Record .....	6
<b>3 General Information</b> .....	<b>7</b>
3.1 General Description of EUT .....	7
3.2 Description of Test Modes .....	9
3.2.1 Test Mode Applicability and Tested Channel Detail .....	10
3.3 Duty Cycle of Test Signal .....	12
3.4 Description of Support Units .....	13
3.4.1 Configuration of System under Test .....	14
3.5 General Description of Applied Standards .....	16
<b>4 Test Types and Results</b> .....	<b>17</b>
4.1 Radiated Emission and Bandedge Measurement .....	17
4.1.1 Limits of Radiated Emission and Bandedge Measurement .....	17
4.1.2 Test Instruments .....	18
4.1.3 Test Procedures .....	19
4.1.4 Deviation from Test Standard .....	19
4.1.5 Test Setup .....	20
4.1.6 EUT Operating Conditions .....	21
4.1.7 Test Results .....	22
4.2 Conducted Emission Measurement .....	36
4.2.1 Limits of Conducted Emission Measurement .....	36
4.2.2 Test Instruments .....	36
4.2.3 Test Procedures .....	37
4.2.4 Deviation from Test Standard .....	37
4.2.5 Test Setup .....	37
4.2.6 EUT Operating Conditions .....	37
4.2.7 Test Results .....	38
4.3 6dB Bandwidth Measurement .....	40
4.3.1 Limits of 6dB Bandwidth Measurement .....	40
4.3.2 Test Setup .....	40
4.3.3 Test Instruments .....	40
4.3.4 Test Procedure .....	40
4.3.5 Deviation from Test Standard .....	40
4.3.6 EUT Operating Conditions .....	40
4.3.7 Test Result .....	41
4.4 Occupied Bandwidth Measurement .....	43
4.4.1 Test Setup .....	43
4.4.2 Test Instruments .....	43
4.4.3 Test Procedure .....	43
4.4.4 Deviation from Test Standard .....	43
4.4.5 EUT Operating Conditions .....	43
4.4.6 Test Results .....	44
4.5 Conducted Output Power Measurement .....	46
4.5.1 Limits of Conducted Output Power Measurement .....	46
4.5.2 Test Setup .....	46
4.5.3 Test Instruments .....	46
4.5.4 Test Procedures .....	46
4.5.5 Deviation from Test Standard .....	46
4.5.6 EUT Operating Conditions .....	46
4.5.7 Test Results .....	47

4.6	Power Spectral Density Measurement.....	49
4.6.1	Limits of Power Spectral Density Measurement .....	49
4.6.2	Test Setup.....	49
4.6.3	Test Instruments .....	49
4.6.4	Test Procedure .....	49
4.6.5	Deviation from Test Standard .....	49
4.6.6	EUT Operating Condition .....	49
4.6.7	Test Results .....	50
4.7	Conducted Out of Band Emission Measurement.....	53
4.7.1	Limits of Conducted Out of Band Emission Measurement.....	53
4.7.2	Test Setup.....	53
4.7.3	Test Instruments .....	53
4.7.4	Test Procedure .....	53
4.7.5	Deviation from Test Standard .....	53
4.7.6	EUT Operating Condition .....	53
4.7.7	Test Results .....	53
<b>5</b>	<b>Pictures of Test Arrangements.....</b>	<b>62</b>
	<b>Appendix – Information of the Testing Laboratories .....</b>	<b>63</b>

### Release Control Record

Issue No.	Description	Date Issued
RF181001E06	Original release.	Nov. 16, 2018

## 1 Certificate of Conformity

**Product:** WIRELESS DOCSIS 3.1 METER

**Brand:** Hitron

**Test Model:** XM2

**Sample Status:** ENGINEERING SAMPLE

**Applicant:** Hitron Technologies Inc.

**Test Date:** Nov. 01 to 06, 2018

**Standards:** 47 CFR FCC Part 15, Subpart C (Section 15.247)  
ANSI C63.10: 2013

The above equipment has been tested by **Bureau Veritas Consumer Products Services (H.K.) Ltd., Taoyuan Branch**, and found compliance with the requirement of the above standards. The test record, data evaluation & Equipment Under Test (EUT) configurations represented herein are true and accurate accounts of the measurements of the sample's EMC characteristics under the conditions specified in this report.

**Prepared by :** Mary Ko , **Date:** Nov. 16, 2018  
Mary Ko / Specialist

**Approved by :** May Chen , **Date:** Nov. 16, 2018  
May Chen / Manager

## 2 Summary of Test Results

47 CFR FCC Part 15, Subpart C (Section 15.247)			
FCC Clause	Test Item	Result	Remarks
15.207	AC Power Conducted Emission	PASS	Meet the requirement of limit. Minimum passing margin is -14.47dB at 0.18125MHz.
15.205 / 15.209 / 15.247(d)	Radiated Emissions and Band Edge Measurement	PASS	Meet the requirement of limit. Minimum passing margin is -0.1dB at 2483.50MHz, 2390.00MHz.
15.247(d)	Antenna Port Emission	PASS	Meet the requirement of limit.
15.247(a)(2)	6dB bandwidth	PASS	Meet the requirement of limit.
15.247(b)	Conducted power	PASS	Meet the requirement of limit.
15.247(e)	Power Spectral Density	PASS	Meet the requirement of limit.
15.203	Antenna Requirement	PASS	Antenna connector is i-pex(MHF) not a standard connector.
-	Occupied Bandwidth Measurement	-	Reference only

### 2.1 Measurement Uncertainty

Where relevant, the following measurement uncertainty levels have been estimated for tests performed on the EUT as specified in CISPR 16-4-2:

Measurement	Frequency	Expanded Uncertainty (k=2) ( $\pm$ )
Conducted Emissions at mains ports	150kHz ~ 30MHz	1.84 dB
Radiated Emissions up to 1 GHz	30MHz ~ 1GHz	5.53 dB
Radiated Emissions above 1 GHz	1GHz ~ 6GHz	5.08 dB
	6GHz ~ 18GHz	4.98 dB
	18GHz ~ 40GHz	5.19 dB

### 2.2 Modification Record

There were no modifications required for compliance.

### 3 General Information

#### 3.1 General Description of EUT

Product	WIRELESS DOCSIS 3.1 METER
Brand	Hitron
Test Model	XM2
Status of EUT	ENGINEERING SAMPLE
Power Supply Rating	DC 10.92V from battery or DC 12 from power adapter
Modulation Type	CCK, DQPSK, DBPSK for DSSS 64QAM, 16QAM, QPSK, BPSK for OFDM 256QAM for OFDM in 11ac mode only
Modulation Technology	DSSS, OFDM
Transfer Rate	802.11b: up to 11Mbps 802.11a/g: up to 54Mbps 802.11n: up to 300Mbps 802.11ac: up to 866.7Mbps
Operating Frequency	<b>2.4GHz:</b> 2.412 ~ 2.462GHz <b>5GHz:</b> 5.18GHz ~ 5.24GHz, 5.745GHz ~ 5.825GHz
Number of Channel	<b>2.4GHz:</b> 802.11b, 802.11g, 802.11n (HT20): 11 802.11n (HT40): 7 <b>5GHz:</b> 802.11a, 802.11n (HT20), 802.11ac (VHT20): 9 802.11n (HT40), 802.11ac (VHT40): 4 802.11ac (VHT80): 2
Output Power	<b>2.4GHz:</b> 675.461mW <b>5.18GHz ~ 5.24GHz:</b> 277.341mW <b>5.745GHz ~ 5.825GHz:</b> 237.156mW
Antenna Type	Refer to Note
Antenna Connector	Refer to Note
Accessory Device	Battery x 1 Adapter x 1
Data Cable Supplied	Power cord x 1 (1.7m, unshielded)

Note:

1. Simultaneously transmission condition.

Condition	Technology	
1	WLAN 2.4GHz	WLAN 5GHz

**Note:** The emission of the simultaneous operation has been evaluated and no non-compliance was found.

2. The EUT could be supplied with a power adapter or battery as the following table:

Adapter			
No.	Brand	Model	Specification
1	AOEM	A0605TD-120050	Input: 100-240V, 50-60Hz, 1.8A Output: 12V, 5.0A (Unshielded 1.5m with one core)
2	APD	DA-60Y12	Input: 100-240V, 50-60Hz, 1.5A Max Output: 12V, 5.0A (Unshielded 1.5m)
Battery			
Brand		Model	Rating
Getac Technology (Kunshan) Co.,Ltd.		HC33 (P/N:39010000917)	DC 10.92 V 8850mAh 96.642Wh
Note:			
1. From the above conditions, the conducted emissions worse case was found in <b>Adapter No. 2</b> . Therefore only the test data of the mode was recorded in this report.			
2. From the above conditions, the radiated emissions worse case was found in <b>Adapter No. 1</b> . Therefore only the test data of the mode was recorded in this report.			

3. The antennas provided to the EUT, please refer to the following table:

Antenna No.	Chain No.	Brand	Model	Antenna Net Gain(dBi)	Frequency range	Antenna Type	Connector Type	Cable Length (mm)
1	Chain 1	Anjie	AJDF2J-B0001	3.82	2.4~2.4835GHz	PCB	i-pex(MHF)	250
				5.1	5.15~5.85GHz	PCB	i-pex(MHF)	
2	Chain 0	Anjie	AJDF2J-C0001	6.36	2.4~2.4835GHz	PCB	i-pex(MHF)	90
				6.94	5.15~5.85GHz	PCB	i-pex(MHF)	

4. The EUT incorporates a MIMO function:

2.4GHz			
MODULATION MODE	DATA RATE (MCS)	TX & RX CONFIGURATION	
802.11b	1 ~ 11Mbps	2TX	2RX
802.11g	6 ~ 54Mbps	2TX	2RX
802.11n (HT20)	MCS 0~7	2TX	2RX
	MCS 8~15	2TX	2RX
802.11n (HT40)	MCS 0~7	2TX	2RX
	MCS 8~15	2TX	2RX
5GHz			
MODULATION MODE	DATA RATE (MCS)	TX & RX CONFIGURATION	
802.11a	6 ~ 54Mbps	2TX	2RX
802.11n (HT20)	MCS 0~7	2TX	2RX
	MCS 8~15	2TX	2RX
802.11n (HT40)	MCS 0~7	2TX	2RX
	MCS 8~15	2TX	2RX
802.11ac (VHT20)	MCS0~8 Nss=1	2TX	2RX
	MCS0~8 Nss=2	2TX	2RX
802.11ac (VHT40)	MCS0~9 Nss=1	2TX	2RX
	MCS0~9 Nss=2	2TX	2RX
802.11ac (VHT80)	MCS0~9 Nss=1	2TX	2RX
	MCS0~9 Nss=2	2TX	2RX

5. The above EUT information is declared by manufacturer and for more detailed features description, please refer to the manufacturer's specifications or user's manual.



### 3.2 Description of Test Modes

11 channels are provided for 802.11b, 802.11g and 802.11n (HT20):

Channel	Frequency	Channel	Frequency
1	2412MHz	7	2442MHz
2	2417MHz	8	2447MHz
3	2422MHz	9	2452MHz
4	2427MHz	10	2457MHz
5	2432MHz	11	2462MHz
6	2437MHz		

7 channels are provided for 802.11n (HT40):

Channel	Frequency	Channel	Frequency
3	2422MHz	7	2442MHz
4	2427MHz	8	2447MHz
5	2432MHz	9	2452MHz
6	2437MHz		

### 3.2.1 Test Mode Applicability and Tested Channel Detail

EUT CONFIGURE MODE	APPLICABLE TO				DESCRIPTION
	RE $\geq$ 1G	RE<1G	PLC	APCM	
-	√	√	√	√	-

Where **RE $\geq$ 1G**: Radiated Emission above 1GHz & Bandedge Measurement  
**RE<1G**: Radiated Emission below 1GHz  
**PLC**: Power Line Conducted Emission  
**APCM**: Antenna Port Conducted Measurement

#### **Radiated Emission Test (Above 1GHz):**

- Pre-Scan has been conducted to determine the worst-case mode from all possible combinations between available modulations, data rates and antenna ports (if EUT with antenna diversity architecture).
- Following channel(s) was (were) selected for the final test as listed below.

MODE	AVAILABLE CHANNEL	TESTED CHANNEL	MODULATION TECHNOLOGY	MODULATION TYPE	DATA RATE (Mbps)
802.11b	1 to 11	1, 6, 11	DSSS	DBPSK	1
802.11g	1 to 11	1, 6, 11	OFDM	BPSK	6
802.11n (HT20)	1 to 11	1, 6, 11	OFDM	BPSK	6.5
802.11n (HT40)	3 to 9	3, 6, 9	OFDM	BPSK	13.5

#### **Radiated Emission Test (Below 1GHz):**

- Pre-Scan has been conducted to determine the worst-case mode from all possible combinations between available modulations, data rates and antenna ports (if EUT with antenna diversity architecture).
- Following channel(s) was (were) selected for the final test as listed below.

MODE	AVAILABLE CHANNEL	TESTED CHANNEL	MODULATION TECHNOLOGY	MODULATION TYPE	DATA RATE (Mbps)
802.11g	1 to 11	6	OFDM	BPSK	6

#### **Power Line Conducted Emission Test:**

- Pre-Scan has been conducted to determine the worst-case mode from all possible combinations between available modulations, data rates and antenna ports (if EUT with antenna diversity architecture).
- Following channel(s) was (were) selected for the final test as listed below.

MODE	AVAILABLE CHANNEL	TESTED CHANNEL	MODULATION TECHNOLOGY	MODULATION TYPE	DATA RATE (Mbps)
802.11g	1 to 11	6	OFDM	BPSK	6

### Antenna Port Conducted Measurement:

- This item includes all test value of each mode, but only includes spectrum plot of worst value of each mode.
- Pre-Scan has been conducted to determine the worst-case mode from all possible combinations between available modulations, data rates and antenna ports (if EUT with antenna diversity architecture).
- Following channel(s) was (were) selected for the final test as listed below.

MODE	AVAILABLE CHANNEL	TESTED CHANNEL	MODULATION TECHNOLOGY	MODULATION TYPE	DATA RATE (Mbps)
802.11b	1 to 11	1, 6, 11	DSSS	DBPSK	1
802.11g	1 to 11	1, 6, 11	OFDM	BPSK	6
802.11n (HT20)	1 to 11	1, 6, 11	OFDM	BPSK	6.5
802.11n (HT40)	3 to 9	3, 6, 9	OFDM	BPSK	13.5

### Test Condition:

Applicable To	Environmental Conditions	Input Power	Tested By
RE $\geq$ 1G	23deg. C, 68%RH	120Vac, 60Hz	Frank Chuang
RE<1G	22deg. C, 67%RH	120Vac, 60Hz	Frank Chuang
PLC	24deg. C, 75%RH	120Vac, 60Hz	Andy Ho
APCM	25deg. C, 60%RH	120Vac, 60Hz	Jyunchun Lin

### 3.3 Duty Cycle of Test Signal

If duty cycle of test signal is  $\geq 98\%$ , duty factor is not required.

If duty cycle of test signal is  $< 98\%$ , duty factor shall be considered.

**802.11b:** Duty cycle =  $12.195/12.304 = 0.991$

**802.11g:** Duty cycle =  $2.028/2.109 = 0.962$ , Duty factor =  $10 * \log(1/0.962) = 0.17$

**802.11n (HT20):** Duty cycle =  $1.888/1.967 = 0.96$ , Duty factor =  $10 * \log(1/0.96) = 0.18$

**802.11n (HT40):** Duty cycle =  $0.926/1.004 = 0.922$ , Duty factor =  $10 * \log(1) = 0.35$

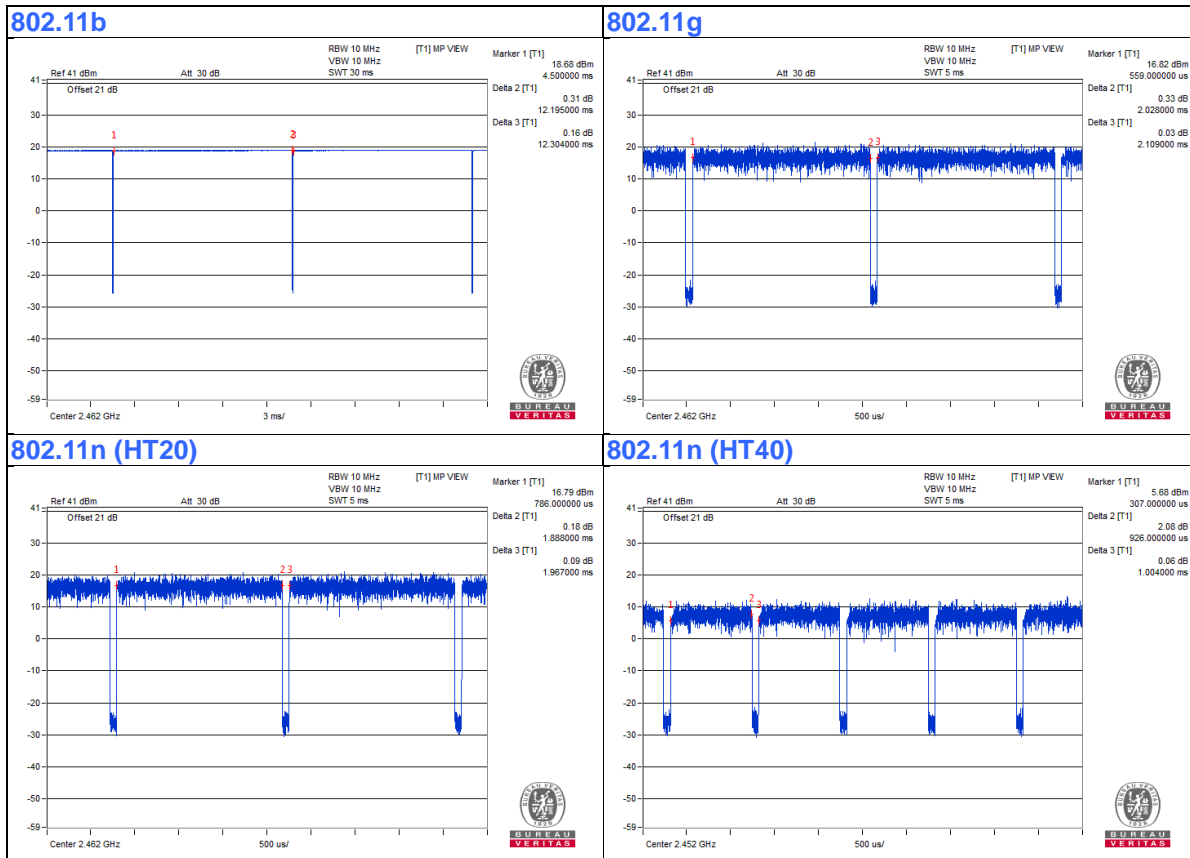

### 3.4 Description of Support Units

The EUT has been tested as an independent unit together with other necessary accessories or support units. The following support units or accessories were used to form a representative test configuration during the tests.

ID	Product	Brand	Model No.	Serial No.	FCC ID	Remarks
A.	USB Disk	Transcend	NA	NA	NA	Provided by Lab
B.	Laptop	DELL	E6420	B92T3R1	FCC DoC	Provided by Lab

Note:

1. All power cords of the above support units are non-shielded (1.8m).

ID	Descriptions	Qty.	Length (m)	Shielding (Yes/No)	Cores (Qty.)	Remarks
1.	AC Cable	1	1.7	No	0	Supplied by client
2.	Console Cable	1	10	No	0	Provided by Lab
3.	Console Cable	1	10	No	0	Provided by Lab
4.	RJ-45 Cable	1	10	No	0	Provided by Lab
5.	DC Cable	1	1.5	No	1	Supplied by client
6.	DC Cable	1	1.5	No	0	Supplied by client

### 3.4.1 Configuration of System under Test

For conducted emission test:

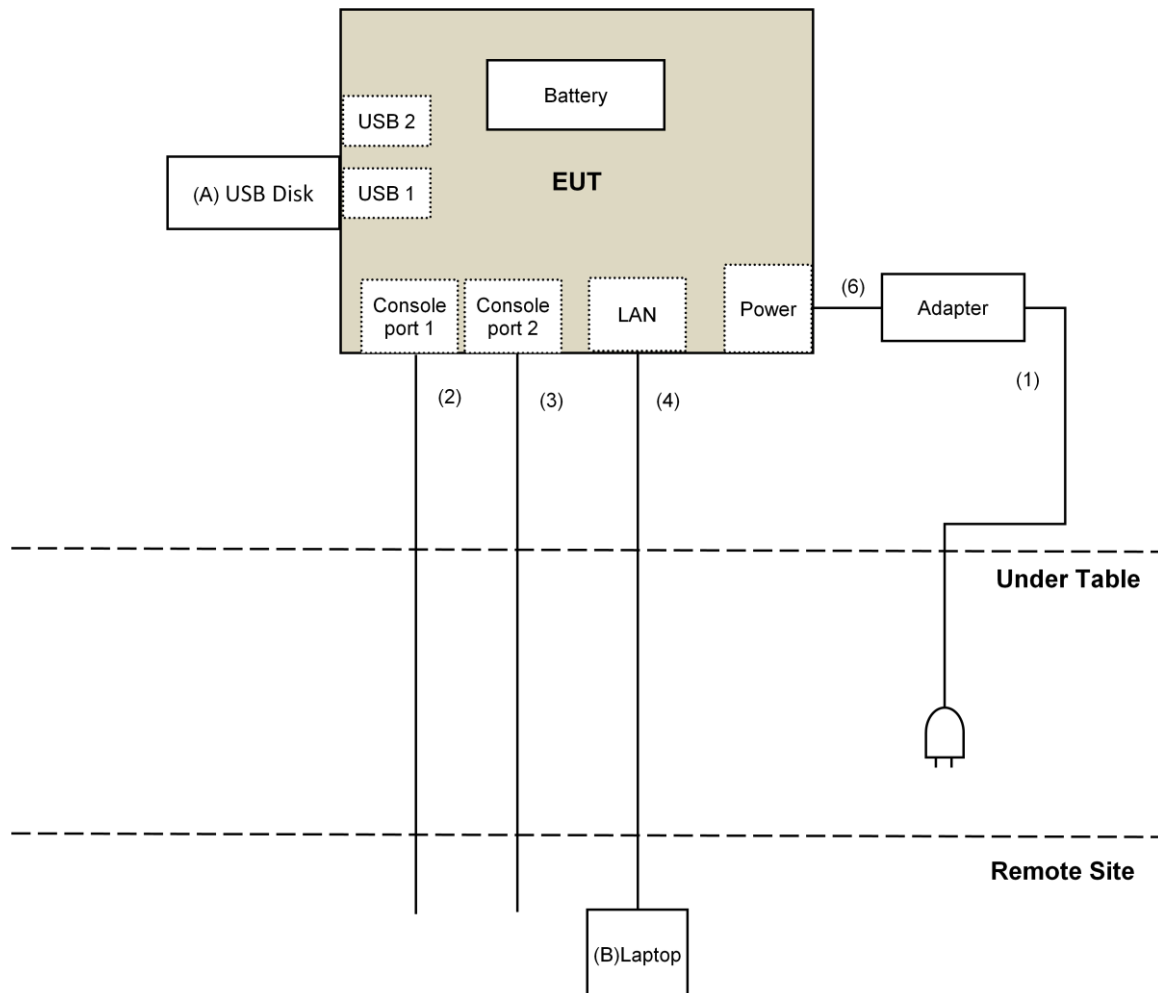

**For radiated emission test:**

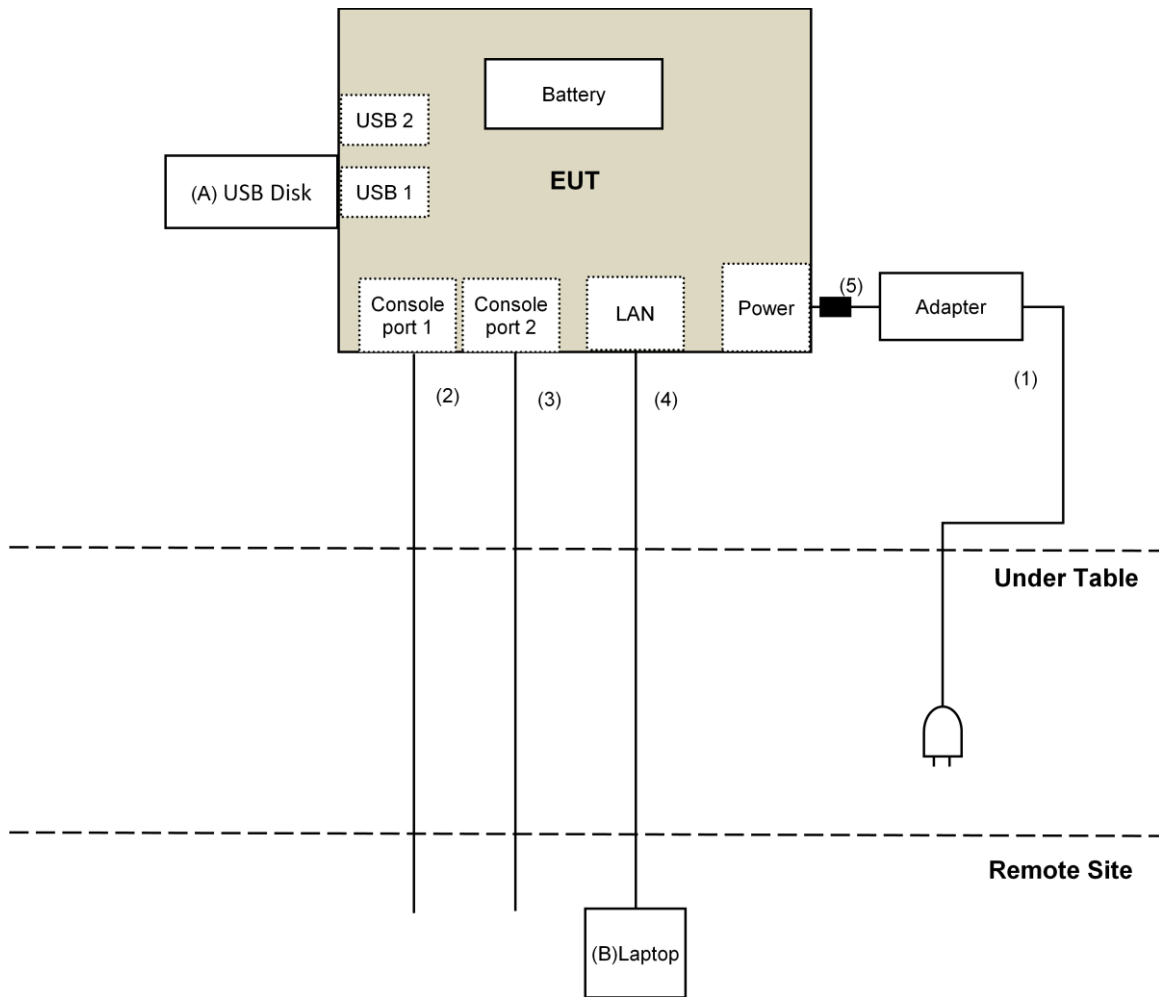

### 3.5 General Description of Applied Standards

The EUT is a RF Product. According to the specifications of the manufacturer, it must comply with the requirements of the following standards:

**FCC Part 15, Subpart C (15.247)**  
**KDB 558074 D01 15.247 Meas Guidance v05**  
**KDB 662911 D01 Multiple Transmitter Output v02r01**  
**ANSI C63.10-2013**

All test items have been performed and recorded as per the above standards.



## 4 Test Types and Results

### 4.1 Radiated Emission and Bandedge Measurement

#### 4.1.1 Limits of Radiated Emission and Bandedge Measurement

Radiated emissions which fall in the restricted bands must comply with the radiated emission limits specified as below table. Other emissions shall be at least 20dB below the highest level of the desired power:

Frequencies (MHz)	Field Strength (microvolts/meter)	Measurement Distance (meters)
0.009 ~ 0.490	2400/F(kHz)	300
0.490 ~ 1.705	24000/F(kHz)	30
1.705 ~ 30.0	30	30
30 ~ 88	100	3
88 ~ 216	150	3
216 ~ 960	200	3
Above 960	500	3

**NOTE:**

1. The lower limit shall apply at the transition frequencies.
2. Emission level (dBuV/m) = 20 log Emission level (uV/m).
3. For frequencies above 1000MHz, the field strength limits are based on average detector, however, the peak field strength of any emission shall not exceed the maximum permitted average limits, specified above by more than 20dB under any condition of modulation.

## 4.1.2 Test Instruments

DESCRIPTION & MANUFACTURER	MODEL NO.	SERIAL NO.	CALIBRATED DATE	CALIBRATED UNTIL
Test Receiver Agilent	N9038A	MY50010156	July 12, 2018	July 11, 2019
Pre-Amplifier EMCI	EMC001340	980142	Feb. 09, 2018	Feb. 08, 2019
Loop Antenna(*) Electro-Metrics	EM-6879	264	Dec. 16, 2016	Dec. 15, 2018
RF Cable	NA	LOOPCAB-001	Jan. 15, 2018	Jan. 14, 2019
RF Cable	NA	LOOPCAB-002	Jan. 15, 2018	Jan. 14, 2019
Pre-Amplifier Mini-Circuits	ZFL-1000VH2B	AMP-ZFL-05	May 05, 2018	May 04, 2019
Trilog Broadband Antenna SCHWARZBECK	VULB 9168	9168-361	Nov. 29, 2017	Nov. 28, 2018
RF Cable	8D	966-3-1	Mar. 20, 2018	Mar. 19, 2019
RF Cable	8D	966-3-2	Mar. 20, 2018	Mar. 19, 2019
RF Cable	8D	966-3-3	Mar. 20, 2018	Mar. 19, 2019
Fixed attenuator Mini-Circuits	UNAT-5+	PAD-3m-3-01	Sep. 27, 2018	Sep. 26, 2019
Horn_Antenna SCHWARZBECK	BBHA9120-D	9120D-406	Dec. 12, 2017	Dec. 11, 2018
Pre-Amplifier EMCI	EMC12630SE	980384	Jan. 29, 2018	Jan. 28, 2019
RF Cable	EMC104-SM-SM-1200	160922	Jan. 29, 2018	Jan. 28, 2019
RF Cable	EMC104-SM-SM-2000	150317	Jan. 29, 2018	Jan. 28, 2019
RF Cable	EMC104-SM-SM-5000	150322	Jan. 29, 2018	Jan. 28, 2019
Spectrum Analyzer Keysight	N9030A	MY54490679	July 23, 2018	July 22, 2019
Pre-Amplifier EMCI	EMC184045SE	980386	Jan. 29, 2018	Jan. 28, 2019
Horn_Antenna SCHWARZBECK	BBHA 9170	BBHA9170608	Dec. 14, 2017	Dec. 13, 2018
RF Cable	EMC102-KM-KM-1200	160924	Jan. 29, 2018	Jan. 28, 2019
Software	ADT_Radiated_V8.7.08	NA	NA	NA
Antenna Tower & Turn Table Max-Full	MF-7802	MF780208406	NA	NA
Boresight Antenna Fixture	FBA-01	FBA-SIP01	NA	NA
Spectrum Analyzer R&S	FSV40	100964	June 20, 2018	June 19, 2019
Power meter Anritsu	ML2495A	1014008	May 09, 2018	May 08, 2019
Power sensor Anritsu	MA2411B	0917122	May 09, 2018	May 08, 2019

**Note:**

1. The calibration interval of the above test instruments is 12 months and the calibrations are traceable to NML/ROC and NIST/USA.
2. \*The calibration interval of the above test instruments is 24 months and the calibrations are traceable to NML/ROC and NIST/USA.
3. The test was performed in 966 Chamber No. 3.
4. The CANADA Site Registration No. is 20331-1
5. Loop antenna was used for all emissions below 30 MHz.
6. Tested Date: Nov. 01 to 06, 2018

#### 4.1.3 Test Procedures

##### **For Radiated emission below 30MHz**

- a. The EUT was placed on the top of a rotating table 0.8 meters above the ground at a 3 meter chamber room. The table was rotated 360 degrees to determine the position of the highest radiation.
- b. The EUT was set 3 meters away from the interference-receiving antenna, which was mounted on the top of a variable-height antenna tower.
- c. Parallel, perpendicular, and ground-parallel orientations of the antenna are set to make the measurement.
- d. For each suspected emission, the EUT was arranged to its worst case and the rotatable table was turned from 0 degrees to 360 degrees to find the maximum reading.
- e. The test-receiver system was set to Quasi-Peak Detect Function and Specified Bandwidth with Maximum Hold Mode.

##### **NOTE:**

1. The resolution bandwidth and video bandwidth of test receiver/spectrum analyzer is 9kHz at frequency below 30MHz.

##### **For Radiated emission above 30MHz**

- a. The EUT was placed on the top of a rotating table 0.8 meters (for 30MHz ~ 1GHz) / 1.5 meters (for above 1GHz) above the ground at 3 meter chamber room for test. The table was rotated 360 degrees to determine the position of the highest radiation.
- b. The EUT was set 3 meters away from the interference-receiving antenna, which was mounted on the top of a variable-height antenna tower.
- c. The height of antenna is varied from one meter to four meters above the ground to determine the maximum value of the field strength. Both horizontal and vertical polarizations of the antenna are set to make the measurement.
- d. For each suspected emission, the EUT was arranged to its worst case and then the antenna was tuned to heights from 1 meter to 4 meters and the rotatable table was turned from 0 degrees to 360 degrees to find the maximum reading.
- e. The test-receiver system was set to quasi-peak detect function and specified bandwidth with maximum hold mode when the test frequency is below 1 GHz.
- f. The test-receiver system was set to peak and average detects function and specified bandwidth with maximum hold mode when the test frequency is above 1 GHz. If the peak reading value also meets average limit, measurement with the average detector is unnecessary.

##### **Note:**

1. The resolution bandwidth and video bandwidth of test receiver/spectrum analyzer is 120kHz for Quasi-peak detection (QP) at frequency below 1GHz.
2. The resolution bandwidth of test receiver/spectrum analyzer is 1 MHz and the video bandwidth is 3 MHz for Peak detection (PK) at frequency above 1GHz.
3. The resolution bandwidth of test receiver/spectrum analyzer is 1MHz and the video bandwidth is  $\geq 1/T$  (Duty cycle < 98%) or 10Hz (Duty cycle  $\geq 98\%$ ) for Average detection (AV) at frequency above 1GHz.
4. All modes of operation were investigated and the worst-case emissions are reported.

#### 4.1.4 Deviation from Test Standard

No deviation.

#### 4.1.5 Test Setup

##### For Radiated emission below 30MHz

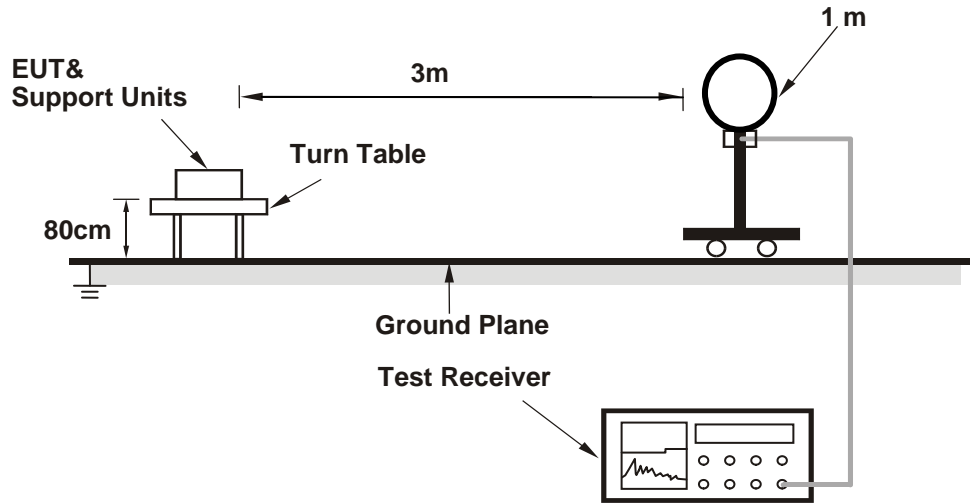

##### For Radiated emission 30MHz to 1GHz

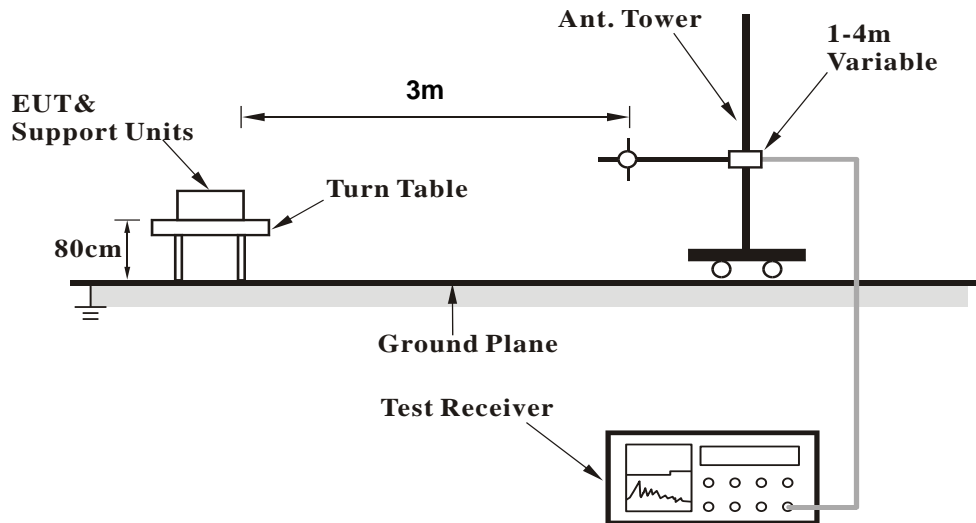

### For Radiated emission above 1GHz

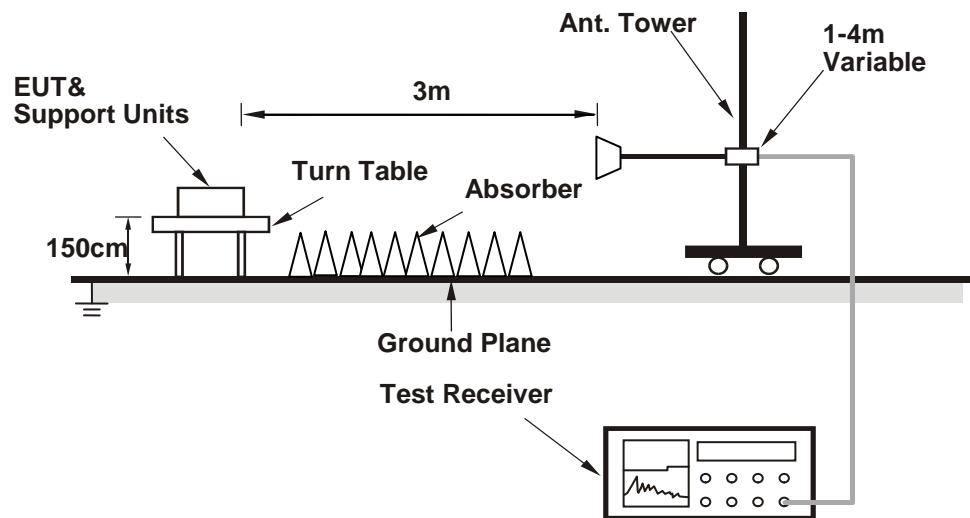

For the actual test configuration, please refer to the attached file (Test Setup Photo).

#### 4.1.6 EUT Operating Conditions

- Connected the EUT with the Laptop which is placed on remote site.
- Controlling software (QDART-Connectivity1000036.exe) has been activated to set the EUT on specific status.

#### 4.1.7 Test Results

#### Above 1GHz Data :

#### 802.11b

<b>CHANNEL</b>	TX Channel 1	<b>DETECTOR FUNCTION</b>	Peak (PK)
<b>FREQUENCY RANGE</b>	1GHz ~ 25GHz		Average (AV)

#### ANTENNA POLARITY & TEST DISTANCE: HORIZONTAL AT 3 M

NO.	FREQ. (MHz)	EMISSION LEVEL (dBuV/m)	LIMIT (dBuV/m)	MARGIN (dB)	ANTENNA HEIGHT (m)	TABLE ANGLE (Degree)	RAW VALUE (dBuV)	CORRECTION FACTOR (dB/m)
1	2390.00	63.4 PK	74.0	-10.6	3.10 H	235	66.1	-2.7
2	2390.00	53.8 AV	54.0	-0.2	3.10 H	235	56.5	-2.7
3	*2412.00	111.1 PK			3.10 H	235	113.8	-2.7
4	*2412.00	109.0 AV			3.10 H	235	111.7	-2.7
5	4824.00	46.8 PK	74.0	-27.2	1.04 H	63	45.2	1.6
6	4824.00	37.4 AV	54.0	-16.6	1.04 H	63	35.8	1.6

#### ANTENNA POLARITY & TEST DISTANCE: VERTICAL AT 3 M

NO.	FREQ. (MHz)	EMISSION LEVEL (dBuV/m)	LIMIT (dBuV/m)	MARGIN (dB)	ANTENNA HEIGHT (m)	TABLE ANGLE (Degree)	RAW VALUE (dBuV)	CORRECTION FACTOR (dB/m)
1	2390.00	63.0 PK	74.0	-11.0	3.10 V	313	65.7	-2.7
2	2390.00	51.2 AV	54.0	-2.8	3.10 V	313	53.9	-2.7
3	*2412.00	109.6 PK			3.10 V	313	112.3	-2.7
4	*2412.00	107.5 AV			3.10 V	313	110.2	-2.7
5	4824.00	49.1 PK	74.0	-24.9	1.25 V	227	47.5	1.6
6	4824.00	40.2 AV	54.0	-13.8	1.25 V	227	38.6	1.6

#### REMARKS:

1. Emission Level(dBuV/m) = Raw Value(dBuV) + Correction Factor(dB/m)
2. Correction Factor(dB/m) = Antenna Factor(dB/m) + Cable Factor(dB) – Pre-Amplifier Factor(dB)
3. The other emission levels were very low against the limit.
4. Margin value = Emission Level – Limit value
5. " \* ": Fundamental frequency.

<b>CHANNEL</b>	TX Channel 6	<b>DETECTOR FUNCTION</b>	Peak (PK)
<b>FREQUENCY RANGE</b>	1GHz ~ 25GHz		Average (AV)

**ANTENNA POLARITY & TEST DISTANCE: HORIZONTAL AT 3 M**

NO.	FREQ. (MHz)	EMISSION LEVEL (dBuV/m)	LIMIT (dBuV/m)	MARGIN (dB)	ANTENNA HEIGHT (m)	TABLE ANGLE (Degree)	RAW VALUE (dBuV)	CORRECTION FACTOR (dB/m)
1	2390.00	62.3 PK	74.0	-11.7	3.04 H	233	65.0	-2.7
2	2390.00	49.7 AV	54.0	-4.3	3.04 H	233	52.4	-2.7
3	*2437.00	115.4 PK			3.04 H	233	118.4	-3.0
4	*2437.00	113.3 AV			3.04 H	233	116.3	-3.0
5	2483.50	63.1 PK	74.0	-10.9	3.04 H	233	66.1	-3.0
<b>6</b>	<b>2483.50</b>	<b>53.9 AV</b>	<b>54.0</b>	<b>-0.1</b>	<b>3.04 H</b>	<b>233</b>	<b>56.9</b>	<b>-3.0</b>
7	4874.00	46.6 PK	74.0	-27.4	1.05 H	89	45.0	1.6
8	4874.00	37.4 AV	54.0	-16.6	1.05 H	89	35.8	1.6
9	7311.00	50.4 PK	74.0	-23.6	1.47 H	157	42.7	7.7
10	7311.00	38.3 AV	54.0	-15.7	1.47 H	157	30.6	7.7

**ANTENNA POLARITY & TEST DISTANCE: VERTICAL AT 3 M**

NO.	FREQ. (MHz)	EMISSION LEVEL (dBuV/m)	LIMIT (dBuV/m)	MARGIN (dB)	ANTENNA HEIGHT (m)	TABLE ANGLE (Degree)	RAW VALUE (dBuV)	CORRECTION FACTOR (dB/m)
1	2390.00	59.8 PK	74.0	-14.2	3.11 V	285	62.5	-2.7
2	2390.00	47.3 AV	54.0	-6.7	3.11 V	285	50.0	-2.7
3	*2437.00	109.8 PK			3.11 V	285	112.8	-3.0
4	*2437.00	107.2 AV			3.11 V	285	110.2	-3.0
5	2483.50	63.0 PK	74.0	-11.0	3.11 V	285	66.0	-3.0
6	2483.50	51.2 AV	54.0	-2.8	3.11 V	285	54.2	-3.0
7	4874.00	53.2 PK	74.0	-20.8	1.25 V	225	51.6	1.6
8	4874.00	45.5 AV	54.0	-8.5	1.25 V	225	43.9	1.6
9	7311.00	52.7 PK	74.0	-21.3	2.12 V	289	45.0	7.7
10	7311.00	42.2 AV	54.0	-11.8	2.12 V	289	34.5	7.7

**REMARKS:**

1. Emission Level(dBuV/m) = Raw Value(dBuV) + Correction Factor(dB/m)
2. Correction Factor(dB/m) = Antenna Factor(dB/m) + Cable Factor(dB) – Pre-Amplifier Factor(dB)
3. The other emission levels were very low against the limit.
4. Margin value = Emission Level – Limit value
5. " \* ": Fundamental frequency.

<b>CHANNEL</b>	TX Channel 11	<b>DETECTOR FUNCTION</b>	Peak (PK)
<b>FREQUENCY RANGE</b>	1GHz ~ 25GHz		Average (AV)

**ANTENNA POLARITY & TEST DISTANCE: HORIZONTAL AT 3 M**

NO.	FREQ. (MHz)	EMISSION LEVEL (dBuV/m)	LIMIT (dBuV/m)	MARGIN (dB)	ANTENNA HEIGHT (m)	TABLE ANGLE (Degree)	RAW VALUE (dBuV)	CORRECTION FACTOR (dB/m)
1	*2462.00	111.0 PK			3.39 H	223	114.0	-3.0
2	*2462.00	109.0 AV			3.39 H	223	112.0	-3.0
3	2483.50	63.7 PK	74.0	-10.3	3.39 H	223	66.7	-3.0
4	2483.50	53.8 AV	54.0	-0.2	3.39 H	223	56.8	-3.0
5	3750.10	49.8 PK	74.0	-24.2	2.11 H	122	50.1	-0.3
6	3750.10	46.0 AV	54.0	-8.0	2.11 H	122	46.3	-0.3
7	4924.00	46.9 PK	74.0	-27.1	1.00 H	75	45.2	1.7
8	4924.00	37.6 AV	54.0	-16.4	1.00 H	75	35.9	1.7
9	7386.00	50.1 PK	74.0	-23.9	1.43 H	154	42.2	7.9
10	7386.00	38.0 AV	54.0	-16.0	1.43 H	154	30.1	7.9

**ANTENNA POLARITY & TEST DISTANCE: VERTICAL AT 3 M**

NO.	FREQ. (MHz)	EMISSION LEVEL (dBuV/m)	LIMIT (dBuV/m)	MARGIN (dB)	ANTENNA HEIGHT (m)	TABLE ANGLE (Degree)	RAW VALUE (dBuV)	CORRECTION FACTOR (dB/m)
1	*2462.00	109.5 PK			3.12 V	298	112.5	-3.0
2	*2462.00	107.1 AV			3.12 V	298	110.1	-3.0
3	2483.50	63.3 PK	74.0	-10.7	3.12 V	298	66.3	-3.0
4	2483.50	51.7 AV	54.0	-2.3	3.12 V	298	54.7	-3.0
5	3750.10	51.9 PK	74.0	-22.1	2.47 V	144	52.2	-0.3
6	3750.10	48.8 AV	54.0	-5.2	2.47 V	144	49.1	-0.3
7	4924.00	47.6 PK	74.0	-26.4	1.26 V	228	45.9	1.7
8	4924.00	38.7 AV	54.0	-15.3	1.26 V	228	37.0	1.7
9	7386.00	51.2 PK	74.0	-22.8	2.14 V	302	43.3	7.9
10	7386.00	39.0 AV	54.0	-15.0	2.14 V	302	31.1	7.9

**REMARKS:**

1. Emission Level(dBuV/m) = Raw Value(dBuV) + Correction Factor(dB/m)
2. Correction Factor(dB/m) = Antenna Factor(dB/m) + Cable Factor(dB) – Pre-Amplifier Factor(dB)
3. The other emission levels were very low against the limit.
4. Margin value = Emission Level – Limit value
5. " \* ": Fundamental frequency.



**802.11g**

<b>CHANNEL</b>	TX Channel 1	<b>DETECTOR FUNCTION</b>	Peak (PK)
<b>FREQUENCY RANGE</b>	1GHz ~ 25GHz		Average (AV)

**ANTENNA POLARITY & TEST DISTANCE: HORIZONTAL AT 3 M**

NO.	FREQ. (MHz)	EMISSION LEVEL (dBuV/m)	LIMIT (dBuV/m)	MARGIN (dB)	ANTENNA HEIGHT (m)	TABLE ANGLE (Degree)	RAW VALUE (dBuV)	CORRECTION FACTOR (dB/m)
1	2390.00	68.9 PK	74.0	-5.1	3.43 H	234	71.6	-2.7
2	2390.00	53.8 AV	54.0	-0.2	3.43 H	234	56.5	-2.7
3	*2412.00	114.6 PK			3.43 H	234	117.3	-2.7
4	*2412.00	102.4 AV			3.43 H	234	105.1	-2.7
5	4824.00	46.9 PK	74.0	-27.1	1.00 H	81	45.3	1.6
6	4824.00	37.7 AV	54.0	-16.3	1.00 H	81	36.1	1.6

**ANTENNA POLARITY & TEST DISTANCE: VERTICAL AT 3 M**

NO.	FREQ. (MHz)	EMISSION LEVEL (dBuV/m)	LIMIT (dBuV/m)	MARGIN (dB)	ANTENNA HEIGHT (m)	TABLE ANGLE (Degree)	RAW VALUE (dBuV)	CORRECTION FACTOR (dB/m)
1	2390.00	63.5 PK	74.0	-10.5	3.11 V	304	66.2	-2.7
2	2390.00	51.7 AV	54.0	-2.3	3.11 V	304	54.4	-2.7
3	*2412.00	102.2 PK			3.11 V	304	104.9	-2.7
4	*2412.00	100.3 AV			3.11 V	304	103.0	-2.7
5	4824.00	49.0 PK	74.0	-25.0	1.20 V	233	47.4	1.6
6	4824.00	40.0 AV	54.0	-14.0	1.20 V	233	38.4	1.6

**REMARKS:**

1. Emission Level(dBuV/m) = Raw Value(dBuV) + Correction Factor(dB/m)
2. Correction Factor(dB/m) = Antenna Factor(dB/m) + Cable Factor(dB) – Pre-Amplifier Factor(dB)
3. The other emission levels were very low against the limit.
4. Margin value = Emission Level – Limit value
5. " \* ": Fundamental frequency.

<b>CHANNEL</b>	TX Channel 6	<b>DETECTOR FUNCTION</b>	Peak (PK)
<b>FREQUENCY RANGE</b>	1GHz ~ 25GHz		Average (AV)

**ANTENNA POLARITY & TEST DISTANCE: HORIZONTAL AT 3 M**

NO.	FREQ. (MHz)	EMISSION LEVEL (dBuV/m)	LIMIT (dBuV/m)	MARGIN (dB)	ANTENNA HEIGHT (m)	TABLE ANGLE (Degree)	RAW VALUE (dBuV)	CORRECTION FACTOR (dB/m)
1	2390.00	68.7 PK	74.0	-5.3	3.41 H	220	71.4	-2.7
2	2390.00	53.6 AV	54.0	-0.4	3.41 H	220	56.3	-2.7
3	*2437.00	118.9 PK			3.41 H	220	121.9	-3.0
4	*2437.00	108.7 AV			3.41 H	220	111.7	-3.0
5	2483.50	69.3 PK	74.0	-4.7	3.41 H	220	72.3	-3.0
6	2483.50	53.1 AV	54.0	-0.9	3.41 H	220	56.1	-3.0
7	4874.00	48.5 PK	74.0	-25.5	1.02 H	85	46.9	1.6
8	4874.00	40.2 AV	54.0	-13.8	1.02 H	85	38.6	1.6
9	7311.00	52.6 PK	74.0	-21.4	1.40 H	149	44.9	7.7
10	7311.00	41.1 AV	54.0	-12.9	1.40 H	149	33.4	7.7

**ANTENNA POLARITY & TEST DISTANCE: VERTICAL AT 3 M**

NO.	FREQ. (MHz)	EMISSION LEVEL (dBuV/m)	LIMIT (dBuV/m)	MARGIN (dB)	ANTENNA HEIGHT (m)	TABLE ANGLE (Degree)	RAW VALUE (dBuV)	CORRECTION FACTOR (dB/m)
1	2390.00	63.1 PK	74.0	-10.9	3.15 V	281	65.8	-2.7
2	2390.00	50.2 AV	54.0	-3.8	3.15 V	281	52.9	-2.7
3	*2437.00	116.2 PK			3.15 V	281	119.2	-3.0
4	*2437.00	106.8 AV			3.15 V	281	109.8	-3.0
5	2483.50	63.2 PK	74.0	-10.8	3.15 V	281	66.2	-3.0
6	2483.50	51.1 AV	54.0	-2.9	3.15 V	281	54.1	-3.0
7	4874.00	40.1 PK	74.0	-33.9	1.30 V	219	38.5	1.6
8	4874.00	39.7 AV	54.0	-14.3	1.30 V	219	38.1	1.6
9	7311.00	51.2 PK	74.0	-22.8	2.16 V	292	43.5	7.7
10	7311.00	41.0 AV	54.0	-13.0	2.16 V	292	33.3	7.7

**REMARKS:**

1. Emission Level(dBuV/m) = Raw Value(dBuV) + Correction Factor(dB/m)
2. Correction Factor(dB/m) = Antenna Factor(dB/m) + Cable Factor(dB) – Pre-Amplifier Factor(dB)
3. The other emission levels were very low against the limit.
4. Margin value = Emission Level – Limit value
5. " \* ": Fundamental frequency.

<b>CHANNEL</b>	TX Channel 11	<b>DETECTOR FUNCTION</b>	Peak (PK)
<b>FREQUENCY RANGE</b>	1GHz ~ 25GHz		Average (AV)

**ANTENNA POLARITY & TEST DISTANCE: HORIZONTAL AT 3 M**

NO.	FREQ. (MHz)	EMISSION LEVEL (dBuV/m)	LIMIT (dBuV/m)	MARGIN (dB)	ANTENNA HEIGHT (m)	TABLE ANGLE (Degree)	RAW VALUE (dBuV)	CORRECTION FACTOR (dB/m)
1	*2462.00	114.1 PK			3.44 H	244	117.1	-3.0
2	*2462.00	103.5 AV			3.44 H	244	106.5	-3.0
3	2483.50	67.2 PK	74.0	-6.8	3.44 H	244	70.2	-3.0
4	2483.50	53.8 AV	54.0	-0.2	3.44 H	244	56.8	-3.0
5	4924.00	44.2 PK	74.0	-29.8	1.00 H	61	42.5	1.7
6	4924.00	35.2 AV	54.0	-18.8	1.00 H	61	33.5	1.7
7	7386.00	47.5 PK	74.0	-26.5	1.44 H	151	39.6	7.9
8	7386.00	36.6 AV	54.0	-17.4	1.44 H	151	28.7	7.9

**ANTENNA POLARITY & TEST DISTANCE: VERTICAL AT 3 M**

NO.	FREQ. (MHz)	EMISSION LEVEL (dBuV/m)	LIMIT (dBuV/m)	MARGIN (dB)	ANTENNA HEIGHT (m)	TABLE ANGLE (Degree)	RAW VALUE (dBuV)	CORRECTION FACTOR (dB/m)
1	*2462.00	112.3 PK			3.10 V	312	115.3	-3.0
2	*2462.00	101.7 AV			3.10 V	312	104.7	-3.0
3	2483.50	63.4 PK	74.0	-10.6	3.10 V	312	66.4	-3.0
4	2483.50	51.9 AV	54.0	-2.1	3.10 V	312	54.9	-3.0
5	4924.00	44.3 PK	74.0	-29.7	1.22 V	233	42.6	1.7
6	4924.00	35.2 AV	54.0	-18.8	1.22 V	233	33.5	1.7
7	7386.00	47.1 PK	74.0	-26.9	2.19 V	302	39.2	7.9
8	7386.00	36.1 AV	54.0	-17.9	2.19 V	302	28.2	7.9

**REMARKS:**

1. Emission Level(dBuV/m) = Raw Value(dBuV) + Correction Factor(dB/m)
2. Correction Factor(dB/m) = Antenna Factor(dB/m) + Cable Factor(dB) – Pre-Amplifier Factor(dB)
3. The other emission levels were very low against the limit.
4. Margin value = Emission Level – Limit value
5. " \* ": Fundamental frequency.

**802.11n (HT20)**

<b>CHANNEL</b>	TX Channel 1	<b>DETECTOR FUNCTION</b>	Peak (PK)
<b>FREQUENCY RANGE</b>	1GHz ~ 25GHz		Average (AV)

**ANTENNA POLARITY & TEST DISTANCE: HORIZONTAL AT 3 M**

NO.	FREQ. (MHz)	EMISSION LEVEL (dBuV/m)	LIMIT (dBuV/m)	MARGIN (dB)	ANTENNA HEIGHT (m)	TABLE ANGLE (Degree)	RAW VALUE (dBuV)	CORRECTION FACTOR (dB/m)
1	2390.00	69.1 PK	74.0	-4.9	3.42 H	226	71.8	-2.7
2	2390.00	53.8 AV	54.0	-0.2	3.42 H	226	56.5	-2.7
3	*2412.00	114.0 PK			3.42 H	226	116.7	-2.7
4	*2412.00	102.0 AV			3.42 H	226	104.7	-2.7
5	4824.00	46.9 PK	74.0	-27.1	1.00 H	86	45.3	1.6
6	4824.00	37.5 AV	54.0	-16.5	1.00 H	86	35.9	1.6

**ANTENNA POLARITY & TEST DISTANCE: VERTICAL AT 3 M**

NO.	FREQ. (MHz)	EMISSION LEVEL (dBuV/m)	LIMIT (dBuV/m)	MARGIN (dB)	ANTENNA HEIGHT (m)	TABLE ANGLE (Degree)	RAW VALUE (dBuV)	CORRECTION FACTOR (dB/m)
1	2390.00	63.6 PK	74.0	-10.4	3.10 V	307	66.3	-2.7
2	2390.00	51.7 AV	54.0	-2.3	3.10 V	307	54.4	-2.7
3	*2412.00	102.7 PK			3.10 V	307	105.4	-2.7
4	*2412.00	100.5 AV			3.10 V	307	103.2	-2.7
5	4824.00	49.4 PK	74.0	-24.6	1.23 V	230	47.8	1.6
6	4824.00	40.1 AV	54.0	-13.9	1.23 V	230	38.5	1.6

**REMARKS:**

1. Emission Level(dBuV/m) = Raw Value(dBuV) + Correction Factor(dB/m)
2. Correction Factor(dB/m) = Antenna Factor(dB/m) + Cable Factor(dB) – Pre-Amplifier Factor(dB)
3. The other emission levels were very low against the limit.
4. Margin value = Emission Level – Limit value
5. " \* ": Fundamental frequency.

<b>CHANNEL</b>	TX Channel 6	<b>DETECTOR FUNCTION</b>	Peak (PK)
<b>FREQUENCY RANGE</b>	1GHz ~ 25GHz		Average (AV)

**ANTENNA POLARITY & TEST DISTANCE: HORIZONTAL AT 3 M**

NO.	FREQ. (MHz)	EMISSION LEVEL (dBuV/m)	LIMIT (dBuV/m)	MARGIN (dB)	ANTENNA HEIGHT (m)	TABLE ANGLE (Degree)	RAW VALUE (dBuV)	CORRECTION FACTOR (dB/m)
1	2390.00	68.9 PK	74.0	-5.1	3.42 H	209	71.6	-2.7
2	2390.00	53.8 AV	54.0	-0.2	3.42 H	209	56.5	-2.7
3	*2437.00	119.4 PK			3.42 H	209	122.4	-3.0
4	*2437.00	109.1 AV			3.42 H	209	112.1	-3.0
5	2483.50	70.0 PK	74.0	-4.0	3.42 H	209	73.0	-3.0
6	2483.50	53.6 AV	54.0	-0.4	3.42 H	209	56.6	-3.0
7	4874.00	48.8 PK	74.0	-25.2	1.00 H	97	47.2	1.6
8	4874.00	40.4 AV	54.0	-13.6	1.00 H	97	38.8	1.6
9	7311.00	52.6 PK	74.0	-21.4	1.43 H	153	44.9	7.7
10	7311.00	41.0 AV	54.0	-13.0	1.43 H	153	33.3	7.7

**ANTENNA POLARITY & TEST DISTANCE: VERTICAL AT 3 M**

NO.	FREQ. (MHz)	EMISSION LEVEL (dBuV/m)	LIMIT (dBuV/m)	MARGIN (dB)	ANTENNA HEIGHT (m)	TABLE ANGLE (Degree)	RAW VALUE (dBuV)	CORRECTION FACTOR (dB/m)
1	2390.00	62.7 PK	74.0	-11.3	3.09 V	268	65.4	-2.7
2	2390.00	49.9 AV	54.0	-4.1	3.09 V	268	52.6	-2.7
3	*2437.00	116.5 PK			3.09 V	268	119.5	-3.0
4	*2437.00	107.3 AV			3.09 V	268	110.3	-3.0
5	2483.50	63.2 PK	74.0	-10.8	3.09 V	268	66.2	-3.0
6	2483.50	51.2 AV	54.0	-2.8	3.09 V	268	54.2	-3.0
7	4874.00	39.9 PK	74.0	-34.1	1.27 V	205	38.3	1.6
8	4874.00	39.4 AV	54.0	-14.6	1.27 V	205	37.8	1.6
9	7311.00	51.6 PK	74.0	-22.4	2.21 V	296	43.9	7.7
10	7311.00	41.4 AV	54.0	-12.6	2.21 V	296	33.7	7.7

**REMARKS:**

1. Emission Level(dBuV/m) = Raw Value(dBuV) + Correction Factor(dB/m)
2. Correction Factor(dB/m) = Antenna Factor(dB/m) + Cable Factor(dB) – Pre-Amplifier Factor(dB)
3. The other emission levels were very low against the limit.
4. Margin value = Emission Level – Limit value
5. " \* ": Fundamental frequency.

<b>CHANNEL</b>	TX Channel 11	<b>DETECTOR FUNCTION</b>	Peak (PK)
<b>FREQUENCY RANGE</b>	1GHz ~ 25GHz		Average (AV)

**ANTENNA POLARITY & TEST DISTANCE: HORIZONTAL AT 3 M**

NO.	FREQ. (MHz)	EMISSION LEVEL (dBuV/m)	LIMIT (dBuV/m)	MARGIN (dB)	ANTENNA HEIGHT (m)	TABLE ANGLE (Degree)	RAW VALUE (dBuV)	CORRECTION FACTOR (dB/m)
1	*2462.00	114.4 PK			3.45 H	243	117.4	-3.0
2	*2462.00	103.8 AV			3.45 H	243	106.8	-3.0
3	2483.50	67.0 PK	74.0	-7.0	3.45 H	243	70.0	-3.0
4	<b>2483.50</b>	<b>53.9 AV</b>	<b>54.0</b>	<b>-0.1</b>	<b>3.45 H</b>	<b>243</b>	<b>56.9</b>	<b>-3.0</b>
5	4924.00	43.8 PK	74.0	-30.2	1.01 H	76	42.1	1.7
6	4924.00	34.8 AV	54.0	-19.2	1.01 H	76	33.1	1.7
7	7386.00	47.1 PK	74.0	-26.9	1.39 H	156	39.2	7.9
8	7386.00	36.3 AV	54.0	-17.7	1.39 H	156	28.4	7.9

**ANTENNA POLARITY & TEST DISTANCE: VERTICAL AT 3 M**

NO.	FREQ. (MHz)	EMISSION LEVEL (dBuV/m)	LIMIT (dBuV/m)	MARGIN (dB)	ANTENNA HEIGHT (m)	TABLE ANGLE (Degree)	RAW VALUE (dBuV)	CORRECTION FACTOR (dB/m)
1	*2462.00	112.8 PK			3.09 V	308	115.8	-3.0
2	*2462.00	102.1 AV			3.09 V	308	105.1	-3.0
3	2483.50	63.4 PK	74.0	-10.6	3.09 V	308	66.4	-3.0
4	2483.50	51.7 AV	54.0	-2.3	3.09 V	308	54.7	-3.0
5	4924.00	44.7 PK	74.0	-29.3	1.28 V	234	43.0	1.7
6	4924.00	35.5 AV	54.0	-18.5	1.28 V	234	33.8	1.7
7	7386.00	47.2 PK	74.0	-26.8	2.14 V	311	39.3	7.9
8	7386.00	36.2 AV	54.0	-17.8	2.14 V	311	28.3	7.9

**REMARKS:**

1. Emission Level(dBuV/m) = Raw Value(dBuV) + Correction Factor(dB/m)
2. Correction Factor(dB/m) = Antenna Factor(dB/m) + Cable Factor(dB) – Pre-Amplifier Factor(dB)
3. The other emission levels were very low against the limit.
4. Margin value = Emission Level – Limit value
5. " \* ": Fundamental frequency.

**802.11n (HT40)**

<b>CHANNEL</b>	TX Channel 3	<b>DETECTOR FUNCTION</b>	Peak (PK)
<b>FREQUENCY RANGE</b>	1GHz ~ 25GHz		Average (AV)

**ANTENNA POLARITY & TEST DISTANCE: HORIZONTAL AT 3 M**

NO.	FREQ. (MHz)	EMISSION LEVEL (dBuV/m)	LIMIT (dBuV/m)	MARGIN (dB)	ANTENNA HEIGHT (m)	TABLE ANGLE (Degree)	RAW VALUE (dBuV)	CORRECTION FACTOR (dB/m)
1	2390.00	68.2 PK	74.0	-5.8	3.49 H	251	70.9	-2.7
<b>2</b>	<b>2390.00</b>	<b>53.9 AV</b>	<b>54.0</b>	<b>-0.1</b>	<b>3.49 H</b>	<b>251</b>	<b>56.6</b>	<b>-2.7</b>
3	*2422.00	103.9 PK			3.49 H	251	106.8	-2.9
4	*2422.00	94.2 AV			3.49 H	251	97.1	-2.9
5	4844.00	43.5 PK	74.0	-30.5	1.06 H	91	41.9	1.6
6	4844.00	32.2 AV	54.0	-21.8	1.06 H	91	30.6	1.6
7	7266.00	45.3 PK	74.0	-28.7	1.44 H	163	37.5	7.8
8	7266.00	35.0 AV	54.0	-19.0	1.44 H	163	27.2	7.8

**ANTENNA POLARITY & TEST DISTANCE: VERTICAL AT 3 M**

NO.	FREQ. (MHz)	EMISSION LEVEL (dBuV/m)	LIMIT (dBuV/m)	MARGIN (dB)	ANTENNA HEIGHT (m)	TABLE ANGLE (Degree)	RAW VALUE (dBuV)	CORRECTION FACTOR (dB/m)
1	2390.00	63.9 PK	74.0	-10.1	3.08 V	320	66.6	-2.7
2	2390.00	51.0 AV	54.0	-3.0	3.08 V	320	53.7	-2.7
3	*2422.00	101.8 PK			3.08 V	320	104.7	-2.9
4	*2422.00	92.2 AV			3.08 V	320	95.1	-2.9
5	4844.00	43.1 PK	74.0	-30.9	1.32 V	222	41.5	1.6
6	4844.00	32.3 AV	54.0	-21.7	1.32 V	222	30.7	1.6
7	7266.00	44.6 PK	74.0	-29.4	2.08 V	324	36.8	7.8
8	7266.00	34.2 AV	54.0	-19.8	2.08 V	324	26.4	7.8

**REMARKS:**

- Emission Level(dBuV/m) = Raw Value(dBuV) + Correction Factor(dB/m)
- Correction Factor(dB/m) = Antenna Factor(dB/m) + Cable Factor(dB) – Pre-Amplifier Factor(dB)
- The other emission levels were very low against the limit.
- Margin value = Emission Level – Limit value
- " \* ": Fundamental frequency.

<b>CHANNEL</b>	TX Channel 6	<b>DETECTOR FUNCTION</b>	Peak (PK)
<b>FREQUENCY RANGE</b>	1GHz ~ 25GHz		Average (AV)

**ANTENNA POLARITY & TEST DISTANCE: HORIZONTAL AT 3 M**

NO.	FREQ. (MHz)	EMISSION LEVEL (dBuV/m)	LIMIT (dBuV/m)	MARGIN (dB)	ANTENNA HEIGHT (m)	TABLE ANGLE (Degree)	RAW VALUE (dBuV)	CORRECTION FACTOR (dB/m)
1	2390.00	66.2 PK	74.0	-7.8	3.48 H	230	68.9	-2.7
2	2390.00	53.5 AV	54.0	-0.5	3.48 H	230	56.2	-2.7
3	*2437.00	109.4 PK			3.48 H	230	112.4	-3.0
4	*2437.00	100.1 AV			3.48 H	230	103.1	-3.0
5	2483.50	63.6 PK	74.0	-10.4	3.48 H	230	66.6	-3.0
6	2483.50	51.3 AV	54.0	-2.7	3.48 H	230	54.3	-3.0
7	4874.00	44.2 PK	74.0	-29.8	1.05 H	91	42.6	1.6
8	4874.00	35.1 AV	54.0	-18.9	1.05 H	91	33.5	1.6
9	7311.00	47.3 PK	74.0	-26.7	1.38 H	160	39.6	7.7
10	7311.00	36.7 AV	54.0	-17.3	1.38 H	160	29.0	7.7

**ANTENNA POLARITY & TEST DISTANCE: VERTICAL AT 3 M**

NO.	FREQ. (MHz)	EMISSION LEVEL (dBuV/m)	LIMIT (dBuV/m)	MARGIN (dB)	ANTENNA HEIGHT (m)	TABLE ANGLE (Degree)	RAW VALUE (dBuV)	CORRECTION FACTOR (dB/m)
1	2390.00	63.1 PK	74.0	-10.9	3.05 V	293	65.8	-2.7
2	2390.00	51.3 AV	54.0	-2.7	3.05 V	293	54.0	-2.7
3	*2437.00	107.6 PK			3.05 V	293	110.6	-3.0
4	*2437.00	98.7 AV			3.05 V	293	101.7	-3.0
5	2483.50	63.1 PK	74.0	-10.9	3.05 V	293	66.1	-3.0
6	2483.50	50.2 AV	54.0	-3.8	3.05 V	293	53.2	-3.0
7	4874.00	44.0 PK	74.0	-30.0	1.30 V	246	42.4	1.6
8	4874.00	35.1 AV	54.0	-18.9	1.30 V	246	33.5	1.6
9	7311.00	47.7 PK	74.0	-26.3	2.11 V	325	40.0	7.7
10	7311.00	36.5 AV	54.0	-17.5	2.11 V	325	28.8	7.7

**REMARKS:**

1. Emission Level(dBuV/m) = Raw Value(dBuV) + Correction Factor(dB/m)
2. Correction Factor(dB/m) = Antenna Factor(dB/m) + Cable Factor(dB) – Pre-Amplifier Factor(dB)
3. The other emission levels were very low against the limit.
4. Margin value = Emission Level – Limit value
5. " \* ": Fundamental frequency.



<b>CHANNEL</b>	TX Channel 9	<b>DETECTOR FUNCTION</b>	Peak (PK)
<b>FREQUENCY RANGE</b>	1GHz ~ 25GHz		Average (AV)

**ANTENNA POLARITY & TEST DISTANCE: HORIZONTAL AT 3 M**

NO.	FREQ. (MHz)	EMISSION LEVEL (dBuV/m)	LIMIT (dBuV/m)	MARGIN (dB)	ANTENNA HEIGHT (m)	TABLE ANGLE (Degree)	RAW VALUE (dBuV)	CORRECTION FACTOR (dB/m)
1	*2452.00	105.1 PK			3.29 H	234	108.1	-3.0
2	*2452.00	95.1 AV			3.29 H	234	98.1	-3.0
3	2483.50	66.7 PK	74.0	-7.3	3.29 H	234	69.7	-3.0
4	2483.50	53.8 AV	54.0	-0.2	3.29 H	234	56.8	-3.0
5	4904.00	43.5 PK	74.0	-30.5	1.00 H	78	41.8	1.7
6	4904.00	32.6 AV	54.0	-21.4	1.00 H	78	30.9	1.7
7	7356.00	45.1 PK	74.0	-28.9	1.37 H	163	37.2	7.9
8	7356.00	34.7 AV	54.0	-19.3	1.37 H	163	26.8	7.9

**ANTENNA POLARITY & TEST DISTANCE: VERTICAL AT 3 M**

NO.	FREQ. (MHz)	EMISSION LEVEL (dBuV/m)	LIMIT (dBuV/m)	MARGIN (dB)	ANTENNA HEIGHT (m)	TABLE ANGLE (Degree)	RAW VALUE (dBuV)	CORRECTION FACTOR (dB/m)
1	*2452.00	101.9 PK			3.02 V	316	104.9	-3.0
2	*2452.00	92.0 AV			3.02 V	316	95.0	-3.0
3	2483.50	63.5 PK	74.0	-10.5	3.02 V	316	66.5	-3.0
4	2483.50	50.6 AV	54.0	-3.4	3.02 V	316	53.6	-3.0
5	4904.00	43.3 PK	74.0	-30.7	1.27 V	224	41.6	1.7
6	4904.00	32.4 AV	54.0	-21.6	1.27 V	224	30.7	1.7
7	7356.00	44.6 PK	74.0	-29.4	2.06 V	331	36.7	7.9
8	7356.00	34.4 AV	54.0	-19.6	2.06 V	331	26.5	7.9

**REMARKS:**

1. Emission Level(dBuV/m) = Raw Value(dBuV) + Correction Factor(dB/m)
2. Correction Factor(dB/m) = Antenna Factor(dB/m) + Cable Factor(dB) – Pre-Amplifier Factor(dB)
3. The other emission levels were very low against the limit.
4. Margin value = Emission Level – Limit value
5. " \* ": Fundamental frequency.

Below 1GHz Data:

802.11g

<b>CHANNEL</b>	TX Channel 6	<b>DETECTOR FUNCTION</b>	Quasi-Peak (QP)
<b>FREQUENCY RANGE</b>	9kHz ~ 1GHz		

**ANTENNA POLARITY & TEST DISTANCE: HORIZONTAL AT 3 M**

NO.	FREQ. (MHz)	EMISSION LEVEL (dBuV/m)	LIMIT (dBuV/m)	MARGIN (dB)	ANTENNA HEIGHT (m)	TABLE ANGLE (Degree)	RAW VALUE (dBuV)	CORRECTION FACTOR (dB/m)
1	41.32	28.9 QP	40.0	-11.1	1.00 H	3	37.0	-8.1
2	230.84	41.8 QP	46.0	-4.2	1.50 H	274	52.0	-10.2
3	500.01	33.8 QP	46.0	-12.2	2.00 H	33	35.8	-2.0
4	625.02	33.6 QP	46.0	-12.4	1.50 H	40	32.7	0.9
5	691.03	37.0 QP	46.0	-9.0	1.00 H	8	35.3	1.7
6	799.99	38.1 QP	46.0	-7.9	2.00 H	220	34.4	3.7

**REMARKS:**

1. Emission Level(dBuV/m) = Raw Value(dBuV) + Correction Factor(dB/m)
2. Correction Factor(dB/m) = Antenna Factor(dB/m) + Cable Factor(dB) – Pre-Amplifier Factor(dB)
3. Margin value = Emission Level – Limit value
4. The emission levels were very low against the limit of frequency range 9kHz~30MHz: the amplitude of spurious emissions attenuated more than 20 dB below the permissible value to be report.

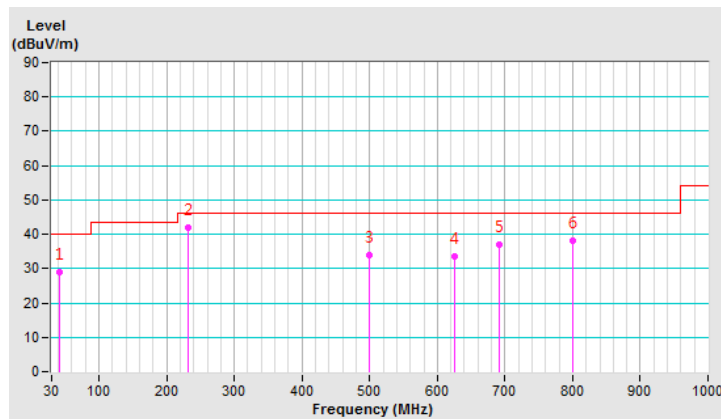

<b>CHANNEL</b>	TX Channel 6	<b>DETECTOR FUNCTION</b>	Quasi-Peak (QP)
<b>FREQUENCY RANGE</b>	9kHz ~ 1GHz		

**ANTENNA POLARITY & TEST DISTANCE: VERTICAL AT 3 M**

NO.	FREQ. (MHz)	EMISSION LEVEL (dBuV/m)	LIMIT (dBuV/m)	MARGIN (dB)	ANTENNA HEIGHT (m)	TABLE ANGLE (Degree)	RAW VALUE (dBuV)	CORRECTION FACTOR (dB/m)
1	58.20	33.5 QP	40.0	-6.5	1.50 V	360	41.8	-8.3
2	232.39	39.4 QP	46.0	-6.6	1.00 V	147	49.4	-10.0
3	298.35	32.7 QP	46.0	-13.3	2.00 V	282	39.7	-7.0
4	400.01	32.8 QP	46.0	-13.2	1.50 V	7	37.3	-4.5
5	500.01	33.7 QP	46.0	-12.3	1.00 V	337	35.7	-2.0
6	799.99	37.0 QP	46.0	-9.0	1.50 V	150	33.3	3.7

**REMARKS:**

1. Emission Level(dBuV/m) = Raw Value(dBuV) + Correction Factor(dB/m)
2. Correction Factor(dB/m) = Antenna Factor(dB/m) + Cable Factor(dB) – Pre-Amplifier Factor(dB)
3. Margin value = Emission Level – Limit value
4. The emission levels were very low against the limit of frequency range 9kHz~30MHz: the amplitude of spurious emissions attenuated more than 20 dB below the permissible value to be report.

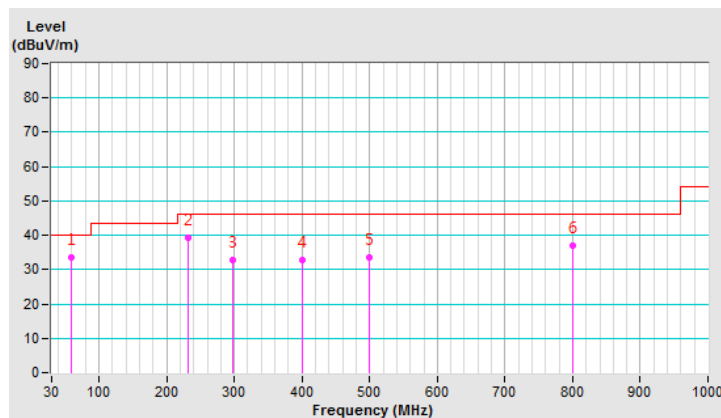

## 4.2 Conducted Emission Measurement

### 4.2.1 Limits of Conducted Emission Measurement

Frequency (MHz)	Conducted Limit (dBuV)	
	Quasi-peak	Average
0.15 - 0.5	66 - 56	56 - 46
0.50 - 5.0	56	46
5.0 - 30.0	60	50

Note: 1. The lower limit shall apply at the transition frequencies.

2. The limit decreases in line with the logarithm of the frequency in the range of 0.15 to 0.50MHz.

### 4.2.2 Test Instruments

DESCRIPTION & MANUFACTURER	MODEL NO.	SERIAL NO.	CALIBRATED DATE	CALIBRATED UNTIL
Test Receiver R&S	ESCS 30	847124/029	Oct. 24, 2018	Oct. 23, 2019
Line-Impedance Stabilization Network (for EUT) R&S	ESH3-Z5	848773/004	Nov. 15, 2017	Nov. 14, 2018
Line-Impedance Stabilization Network (for Peripheral) R&S	ENV216	100072	June 04, 2018	June 03, 2019
50 ohms Terminator	N/A	EMC-02	Sep. 12, 2018	Sep. 11, 2019
RF Cable	5D-FB	COCCAB-001	Sep. 28, 2018	Sep. 27, 2019
Fixed attenuator EMCI	STI02-2200-10	003	Mar. 16, 2018	Mar. 15, 2019
Software BVADT	BVADT_Cond_ V7.3.7.4	NA	NA	NA

**Note:**

1. The calibration interval of the above test instruments are 12 months and the calibrations are traceable to NML/ROC and NIST/USA.
2. The test was performed in Conduction 1.
3. Tested Date: Nov. 02, 2018

#### 4.2.3 Test Procedures

- a. The EUT was placed 0.4 meters from the conducting wall of the shielded room with EUT being connected to the power mains through a line impedance stabilization network (LISN). Other support units were connected to the power mains through another LISN. The two LISNs provide 50 ohm/ 50uH of coupling impedance for the measuring instrument.
- b. Both lines of the power mains connected to the EUT were checked for maximum conducted interference.
- c. The frequency range from 150kHz to 30MHz was searched. Emission levels under (Limit - 20dB) was not recorded.

**NOTE:** The resolution bandwidth and video bandwidth of test receiver is 9kHz for quasi-peak detection (QP) and average detection (AV) at frequency 0.15MHz-30MHz.

#### 4.2.4 Deviation from Test Standard

No deviation.

#### 4.2.5 Test Setup

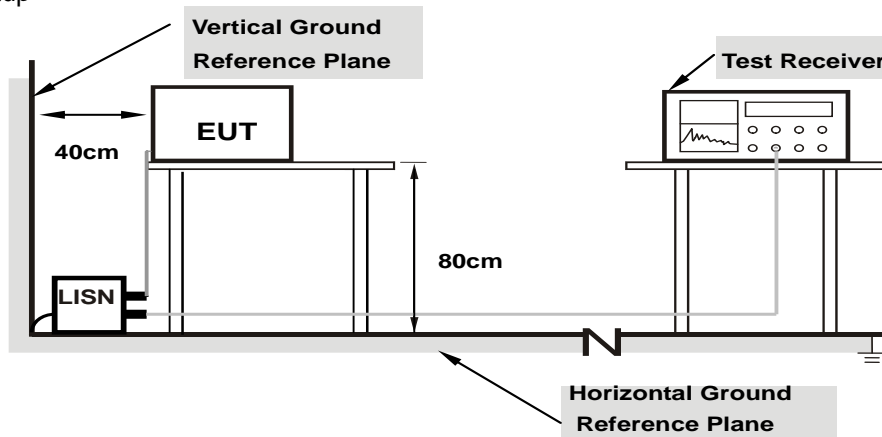

**Note:** 1.Support units were connected to second LISN.

For the actual test configuration, please refer to the attached file (Test Setup Photo).

#### 4.2.6 EUT Operating Conditions

Same as 4.1.6.

#### 4.2.7 Test Results

Phase	Line (L)	Detector Function	Quasi-Peak (QP) / Average (AV)
-------	----------	-------------------	--------------------------------

No	Freq. [MHz]	Corr. Factor	Reading Value [dB (uV)]		Emission Level [dB (uV)]		Limit [dB (uV)]		Margin (dB)	
		(dB)	Q.P.	AV.	Q.P.	AV.	Q.P.	AV.	Q.P.	AV.
	1	0.15000	10.02	40.23	20.11	50.25	30.13	66.00	56.00	-15.75
<b>2</b>	<b>0.18125</b>	<b>10.03</b>	<b>39.93</b>	<b>23.30</b>	<b>49.96</b>	<b>33.33</b>	<b>64.43</b>	<b>54.43</b>	<b>-14.47</b>	<b>-21.10</b>
3	0.24766	10.05	32.79	21.13	42.84	31.18	61.84	51.84	-19.00	-20.66
4	0.30234	10.06	27.67	13.94	37.73	24.00	60.18	50.18	-22.45	-26.18
5	4.64063	10.28	22.43	14.17	32.71	24.45	56.00	46.00	-23.29	-21.55
6	22.37891	11.11	27.01	20.76	38.12	31.87	60.00	50.00	-21.88	-18.13

#### REMARKS:

1. Q.P. and AV. are abbreviations of quasi-peak and average individually.
2. The emission levels of other frequencies were very low against the limit.
3. Margin value = Emission level - Limit value
4. Correction factor = Insertion loss + Cable loss
5. Emission Level = Correction Factor + Reading Value.

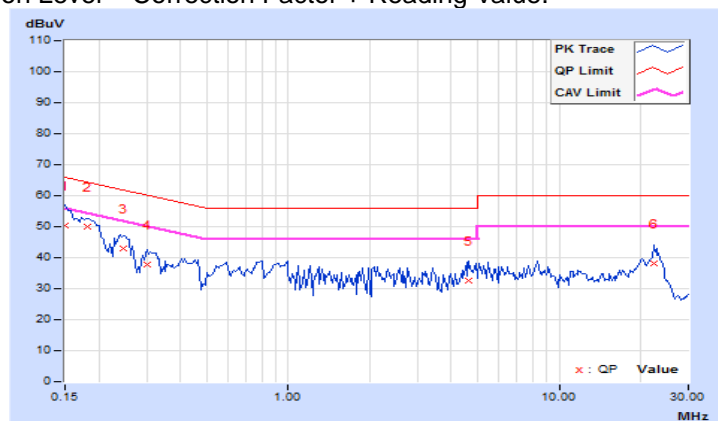

Phase	Neutral (N)	Detector Function	Quasi-Peak (QP) / Average (AV)
-------	-------------	-------------------	--------------------------------

No	Freq. [MHz]	Corr. Factor	Reading Value [dB (uV)]		Emission Level [dB (uV)]		Limit [dB (uV)]		Margin (dB)	
		(dB)	Q.P.	AV.	Q.P.	AV.	Q.P.	AV.	Q.P.	AV.
	1	0.15391	9.93	39.99	20.94	49.92	30.87	65.79	55.79	-15.87
2	0.17734	9.94	39.36	21.99	49.30	31.93	64.61	54.61	-15.31	-22.68
3	0.23594	9.94	31.73	17.60	41.67	27.54	62.24	52.24	-20.57	-24.70
4	0.79844	9.98	24.21	10.20	34.19	20.18	56.00	46.00	-21.81	-25.82
5	1.45313	10.01	23.57	12.08	33.58	22.09	56.00	46.00	-22.42	-23.91
6	5.13281	10.17	21.97	13.64	32.14	23.81	60.00	50.00	-27.86	-26.19
7	22.90625	10.90	26.24	19.99	37.14	30.89	60.00	50.00	-22.86	-19.11

**REMARKS:**

1. Q.P. and AV. are abbreviations of quasi-peak and average individually.
2. The emission levels of other frequencies were very low against the limit.
3. Margin value = Emission level - Limit value
4. Correction factor = Insertion loss + Cable loss
5. Emission Level = Correction Factor + Reading Value.

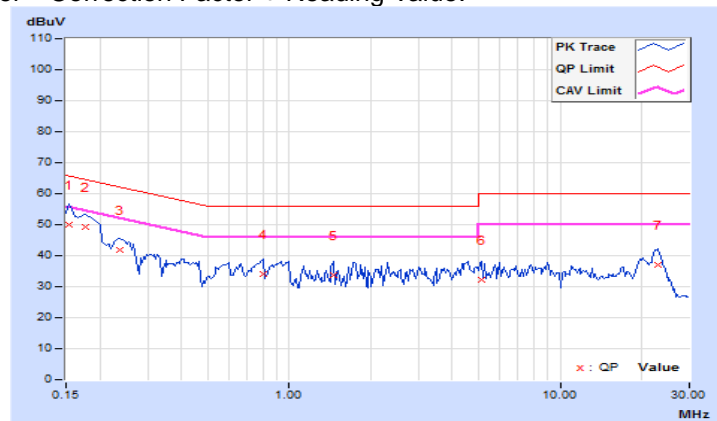

### 4.3 6dB Bandwidth Measurement

#### 4.3.1 Limits of 6dB Bandwidth Measurement

The minimum of 6dB Bandwidth Measurement is 0.5 MHz.

#### 4.3.2 Test Setup

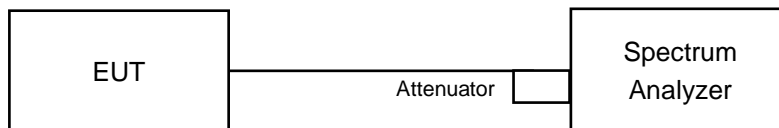

#### 4.3.3 Test Instruments

Refer to section 4.1.2 to get information of above instrument.

#### 4.3.4 Test Procedure

- a. Set resolution bandwidth (RBW) = 100kHz
- b. Set the video bandwidth (VBW)  $\geq 3 \times$  RBW, Detector = Peak.
- c. Trace mode = max hold.
- d. Sweep = auto couple.
- e. Measure the maximum width of the emission that is constrained by the frequencies associated with the two amplitude points (upper and lower) that are attenuated by 6 dB relative to the maximum level measured in the fundamental emission

#### 4.3.5 Deviation from Test Standard

No deviation.

#### 4.3.6 EUT Operating Conditions

The software provided by client to enable the EUT under transmission condition continuously at lowest, middle and highest channel frequencies individually.



#### 4.3.7 Test Result

##### 802.11b

Channel	Frequency (MHz)	6dB Bandwidth (MHz)		Minimum Limit (MHz)	Pass / Fail
		Chain 0	Chain 1		
1	2412	10.13	10.14	0.5	Pass
6	2437	10.12	10.13	0.5	Pass
11	2462	10.11	10.12	0.5	Pass

##### 802.11g

Channel	Frequency (MHz)	6dB Bandwidth (MHz)		Minimum Limit (MHz)	Pass / Fail
		Chain 0	Chain 1		
1	2412	16.40	17.56	0.5	Pass
6	2437	16.38	16.35	0.5	Pass
11	2462	16.37	16.38	0.5	Pass

##### 802.11n (HT20)

Channel	Frequency (MHz)	6dB Bandwidth (MHz)		Minimum Limit (MHz)	Pass / Fail
		Chain 0	Chain 1		
1	2412	17.63	17.58	0.5	Pass
6	2437	17.34	17.34	0.5	Pass
11	2462	17.60	17.41	0.5	Pass

##### 802.11n (HT40)

Channel	Frequency (MHz)	6dB Bandwidth (MHz)		Minimum Limit (MHz)	Pass / Fail
		Chain 0	Chain 1		
3	2422	36.43	36.05	0.5	Pass
6	2437	35.70	36.15	0.5	Pass
9	2452	36.49	36.17	0.5	Pass

### Spectrum Plot of Worst Value

**802.11b / Chain 0 : CH11**

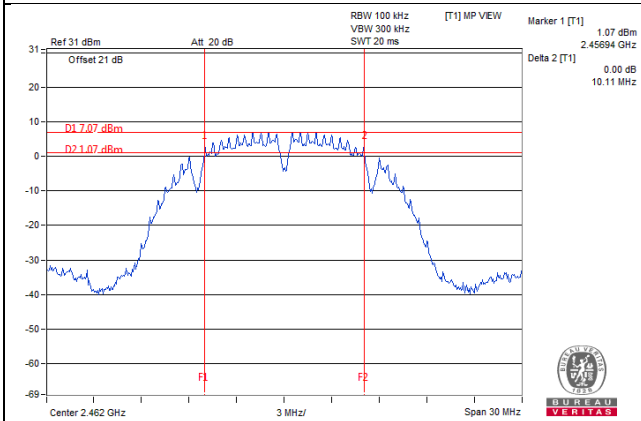

**802.11g / Chain 1 : CH6**

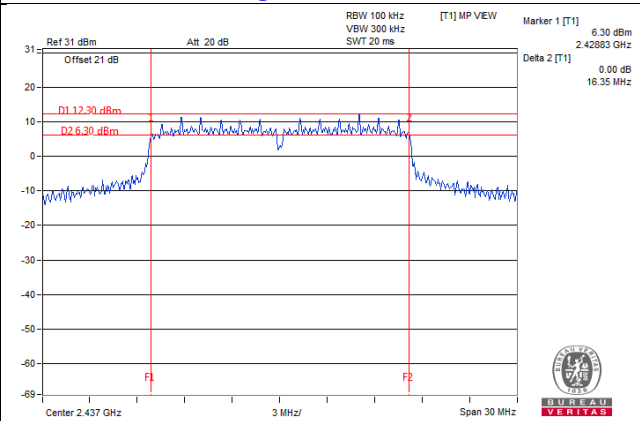

**802.11n (HT20) / Chain 1 : CH6**

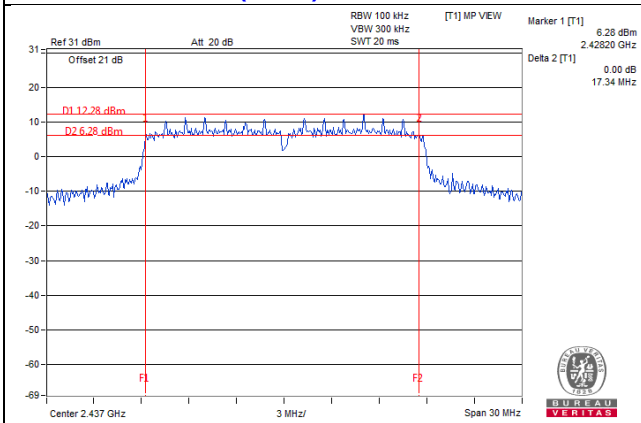

**802.11n (HT40) / Chain 0 : CH6**

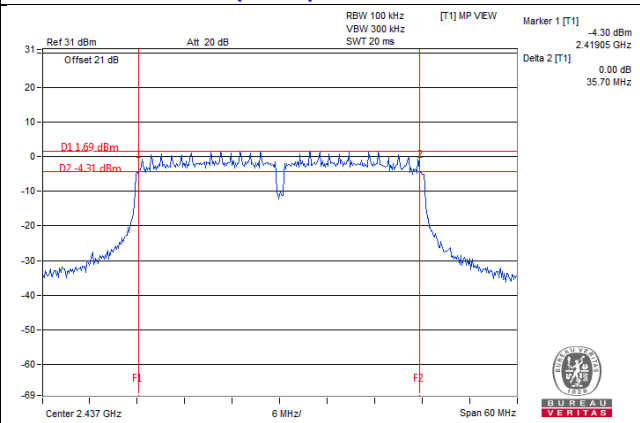

## 4.4 Occupied Bandwidth Measurement

### 4.4.1 Test Setup

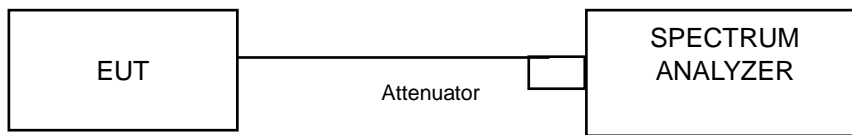

### 4.4.2 Test Instruments

Refer to section 4.1.2 to get information of above instrument.

### 4.4.3 Test Procedure

The transmitter output was connected to the spectrum analyzer through an attenuator. The bandwidth of the fundamental frequency was measured by spectrum analyzer with resolution bandwidth in the range of 1% to 5% of the anticipated emission bandwidth, and a video bandwidth at least 3x the resolution bandwidth and set the detector to sampling. The width of a frequency band such that, below the lower and above the upper frequency limits, the mean powers emitted are each equal to a specified percentage 0.5 %of the total mean power of a given emission.

### 4.4.4 Deviation from Test Standard

No deviation.

### 4.4.5 EUT Operating Conditions

The software provided by client to enable the EUT under transmission condition continuously at lowest, middle and highest channel frequencies individually.

#### 4.4.6 Test Results

##### 802.11b

Channel	Frequency (MHz)	Occupied Bandwidth (MHz)	
		Chain 0	Chain 1
1	2412	13.92	13.92
6	2437	14.52	14.64
11	2462	13.92	13.92

##### 802.11g

Channel	Frequency (MHz)	Occupied Bandwidth (MHz)	
		Chain 0	Chain 1
1	2412	16.68	17.88
6	2437	22.08	22.80
11	2462	16.68	16.68

##### 802.11n (HT20)

Channel	Frequency (MHz)	Occupied Bandwidth (MHz)	
		Chain 0	Chain 1
1	2412	17.76	17.76
6	2437	23.04	23.28
11	2462	17.88	17.76

##### 802.11n (HT40)

Channel	Frequency (MHz)	Occupied Bandwidth (MHz)	
		Chain 0	Chain 1
3	2422	36.96	36.72
6	2437	36.48	36.48
9	2452	36.72	36.96

Spectrum Plot of Worst Value

802.11b / Chain 1 : CH6

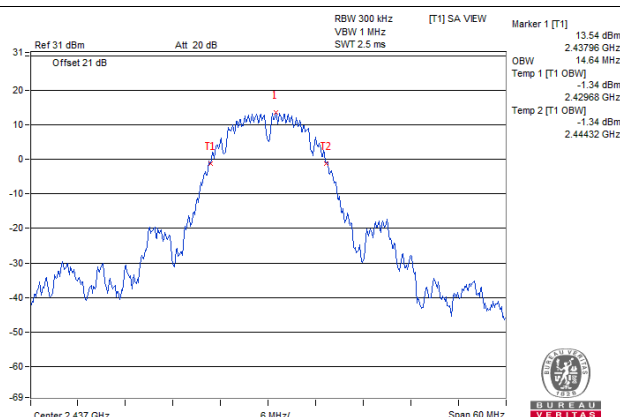

802.11g / Chain 1 : CH6

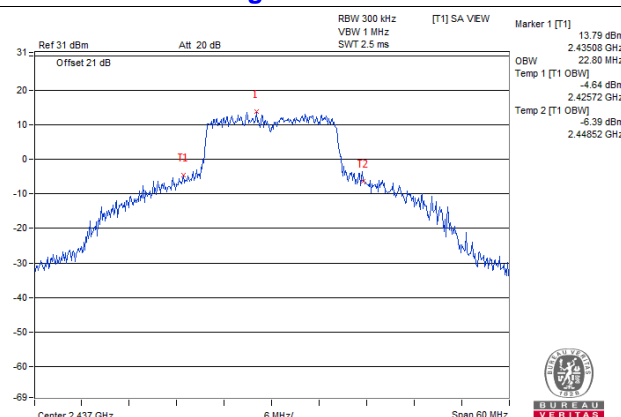

802.11n (HT20) / Chain 1 : CH6

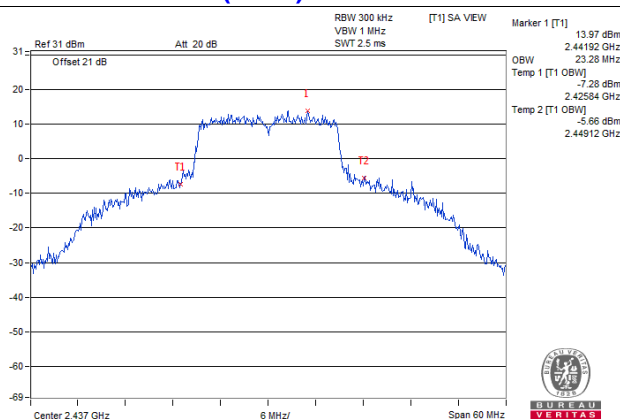

802.11n (HT40) / Chain 0 : CH3

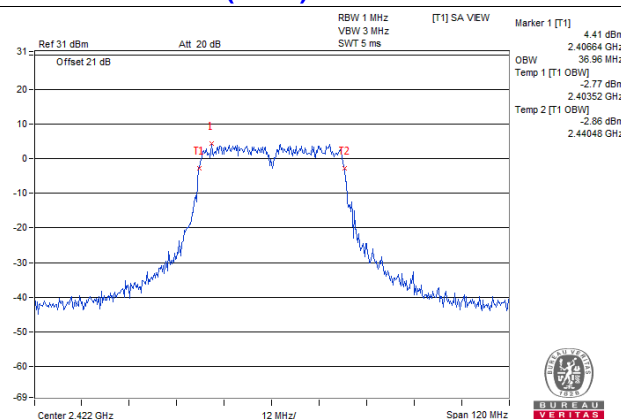

## 4.5 Conducted Output Power Measurement

### 4.5.1 Limits of Conducted Output Power Measurement

For systems using digital modulation in the 2400–2483.5 MHz bands: 1 Watt (30dBm)

Per KDB 662911 D01 Multiple Transmitter Output Method of conducted output power measurement on IEEE 802.11 devices,

Array Gain = 0 dB (i.e., no array gain) for  $N_{ANT} \leq 4$ ;

Array Gain = 0 dB (i.e., no array gain) for channel widths  $\geq 40$  MHz for any  $N_{ANT}$ ;

Array Gain =  $5 \log(N_{ANT}/N_{SS})$  dB or 3 dB, whichever is less for 20-MHz channel widths with  $N_{ANT} \geq 5$ .

For power measurements on all other devices: Array Gain =  $10 \log(N_{ANT}/N_{SS})$  dB.

### 4.5.2 Test Setup

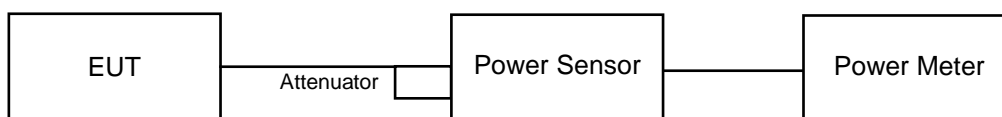

### 4.5.3 Test Instruments

Refer to section 4.1.2 to get information of above instrument.

### 4.5.4 Test Procedures

A peak power sensor was used on the output port of the EUT. A power meter was used to read the response of the peak power sensor. Record the power level.

Average power sensor was used to perform output power measurement, trigger and gating function of wide band power meter is enabled to measure max output power of TX on burst. Duty factor is not added to measured value.

### 4.5.5 Deviation from Test Standard

No deviation.

### 4.5.6 EUT Operating Conditions

Same as Item 4.3.6.

#### 4.5.7 Test Results

#### FOR PEAK POWER

##### 802.11b

Chan.	Freq. (MHz)	Peak Power (dBm)		Total Power (mW)	Total Power (dBm)	Limit (dBm)	Pass / Fail
		Chain 0	Chain 1				
1	2412	20.21	20.74	223.531	23.49	29.64	Pass
6	2437	23.87	24.52	526.92	27.22	29.64	Pass
11	2462	18.62	19.47	161.29	22.08	29.64	Pass

**Note:** 1. Max. gain = 6.36dBi > 6dBi , so the power limit shall be reduced to  $30-(6.36-6) = 29.64$ dBm.

##### 802.11g

Chan.	Freq. (MHz)	Peak Power (dBm)		Total Power (mW)	Total Power (dBm)	Limit (dBm)	Pass / Fail
		Chain 0	Chain 1				
1	2412	22.10	22.78	351.852	25.46	29.64	Pass
6	2437	24.97	25.58	675.461	28.30	29.64	Pass
11	2462	21.13	21.91	284.957	24.55	29.64	Pass

**Note:** 1. Max. gain = 6.36dBi > 6dBi , so the power limit shall be reduced to  $30-(6.36-6) = 29.64$ dBm.

##### 802.11n (HT20)

Chan.	Freq. (MHz)	Peak Power (dBm)		Total Power (mW)	Total Power (dBm)	Limit (dBm)	Pass / Fail
		Chain 0	Chain 1				
1	2412	22.23	22.71	353.747	25.49	29.64	Pass
6	2437	25.01	25.54	675.053	28.29	29.64	Pass
11	2462	21.02	21.74	275.753	24.41	29.64	Pass

**Note:** 1. Max. gain = 6.36dBi > 6dBi , so the power limit shall be reduced to  $30-(6.36-6) = 29.64$ dBm.

##### 802.11n (HT40)

Chan.	Freq. (MHz)	Peak Power (dBm)		Total Power (mW)	Total Power (dBm)	Limit (dBm)	Pass / Fail
		Chain 0	Chain 1				
3	2422	16.72	17.28	100.445	20.02	29.64	Pass
6	2437	21.81	22.29	321.139	25.07	29.64	Pass
9	2452	15.56	16.32	78.83	18.97	29.64	Pass

**Note:** 1. Max. gain = 6.36dBi > 6dBi , so the power limit shall be reduced to  $30-(6.36-6) = 29.64$ dBm.

**FOR AVERAGE POWER**
**802.11b**

Chan.	Frequency (MHz)	Avg. Power (dBm)		Total Power (mW)	Total Power (dBm)
		Chain 0	Chain 1		
1	2412	18.12	18.51	135.821	21.33
6	2437	22.15	22.76	352.858	25.48
11	2462	16.37	17.20	95.832	19.82

**802.11g**

Chan.	Frequency (MHz)	Avg. Power (dBm)		Total Power (mW)	Total Power (dBm)
		Chain 0	Chain 1		
1	2412	16.59	16.95	95.149	19.78
6	2437	21.77	22.43	325.299	25.12
11	2462	15.24	15.96	72.866	18.63

**802.11n (HT20)**

Chan.	Frequency (MHz)	Avg. Power (dBm)		Total Power (mW)	Total Power (dBm)
		Chain 0	Chain 1		
1	2412	16.58	16.94	94.93	19.77
6	2437	21.84	22.51	330.995	25.20
11	2462	15.33	15.91	73.113	18.64

**802.11n (HT40)**

Chan.	Frequency (MHz)	Avg. Power (dBm)		Total Power (mW)	Total Power (dBm)
		Chain 0	Chain 1		
3	2422	11.10	11.50	27.007	14.31
6	2437	16.01	16.57	85.296	19.31
9	2452	9.68	10.30	20.005	13.01



## 4.6 Power Spectral Density Measurement

### 4.6.1 Limits of Power Spectral Density Measurement

The Maximum of Power Spectral Density Measurement is 8dBm in any 3 kHz.

### 4.6.2 Test Setup

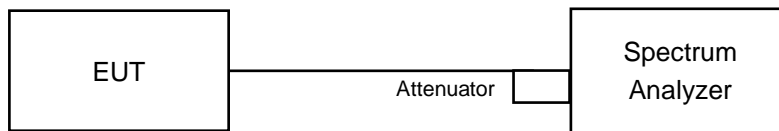

### 4.6.3 Test Instruments

Refer to section 4.1.2 to get information of above instrument.

### 4.6.4 Test Procedure

- a. Set analyzer center frequency to DTS channel center frequency.
- b. Set the span to 1.5 times the DTS bandwidth.
- c. Set the RBW to:  $3 \text{ kHz} \leq \text{RBW} \leq 100 \text{ kHz}$ .
- d. Set the VBW  $\geq 3 \times \text{RBW}$ .
- e. Detector = peak.
- f. Sweep time = auto couple.
- g. Trace mode = max hold.
- h. Allow trace to fully stabilize.
- i. Use the peak marker function to determine the maximum amplitude level within the RBW.

### 4.6.5 Deviation from Test Standard

No deviation.

### 4.6.6 EUT Operating Condition

Same as Item 4.3.6

#### 4.6.7 Test Results

##### 802.11b

TX chain	Channel	Freq. (MHz)	PSD (dBm/3kHz)	10 log (N=2) dB	Total PSD (dBm/3kHz)	Limit (dBm/3kHz)	Pass /Fail
0	1	2412	-4.89	3.01	-1.88	5.81	Pass
	6	2437	-1.48	3.01	1.53	5.81	Pass
	11	2462	-7.12	3.01	-4.11	5.81	Pass
1	1	2412	-5.10	3.01	-2.09	5.81	Pass
	6	2437	-1.91	3.01	1.10	5.81	Pass
	11	2462	-7.14	3.01	-4.13	5.81	Pass

**Note:** 1. Directional gain =  $10 \log[(10^{G0/20} + 10^{G1/20})^2 / 2] = 8.19\text{dBi} > 6\text{dBi}$ , so the power density limit shall be reduced to  $8 - (8.19 - 6) = 5.81\text{dBm}$ .

##### 802.11g

TX chain	Channel	Freq. (MHz)	PSD (dBm/3kHz)	10 log (N=2) dB	Total PSD (dBm/3kHz)	Limit (dBm/3kHz)	Pass /Fail
0	1	2412	-9.06	3.01	-6.05	5.81	Pass
	6	2437	-2.97	3.01	0.04	5.81	Pass
	11	2462	-10.59	3.01	-7.58	5.81	Pass
1	1	2412	-9.15	3.01	-6.14	5.81	Pass
	6	2437	-3.91	3.01	-0.90	5.81	Pass
	11	2462	-8.41	3.01	-5.40	5.81	Pass

**Note:** 1. Directional gain =  $10 \log[(10^{G0/20} + 10^{G1/20})^2 / 2] = 8.19\text{dBi} > 6\text{dBi}$ , so the power density limit shall be reduced to  $8 - (8.19 - 6) = 5.81\text{dBm}$ .

##### 802.11n (HT20)

TX chain	Channel	Freq. (MHz)	PSD (dBm/3kHz)	10 log (N=2) dB	Total PSD (dBm/3kHz)	Limit (dBm/3kHz)	Pass /Fail
0	1	2412	-9.96	3.01	-6.95	5.81	Pass
	6	2437	-3.45	3.01	-0.44	5.81	Pass
	11	2462	-11.02	3.01	-8.01	5.81	Pass
1	1	2412	-8.91	3.01	-5.90	5.81	Pass
	6	2437	-4.04	3.01	-1.03	5.81	Pass
	11	2462	-10.33	3.01	-7.32	5.81	Pass

**Note:** 1. Directional gain =  $10 \log[(10^{G0/20} + 10^{G1/20})^2 / 2] = 8.19\text{dBi} > 6\text{dBi}$ , so the power density limit shall be reduced to  $8 - (8.19 - 6) = 5.81\text{dBm}$ .

### 802.11n (HT40)

TX chain	Channel	Freq. (MHz)	PSD (dBm/3kHz)	10 log (N=2) dB	Total PSD (dBm/3kHz)	Limit (dBm/3kHz)	Pass /Fail
0	3	2422	-17.68	3.01	-14.67	5.81	Pass
	6	2437	-13.21	3.01	-10.20	5.81	Pass
	9	2452	-19.07	3.01	-16.06	5.81	Pass
1	3	2422	-17.93	3.01	-14.92	5.81	Pass
	6	2437	-11.41	3.01	-8.40	5.81	Pass
	9	2452	-18.73	3.01	-15.72	5.81	Pass

**Note:** 1. Directional gain =  $10 \log[(10^{G_0/20} + 10^{G_1/20})^2 / 2] = 8.19\text{dBi} > 6\text{dBi}$  , so the power density limit shall be reduced to  $8 - (8.19 - 6) = 5.81\text{dBm}$ .

Spectrum Plot of Worst Value

802.11b / Chain 0: CH6

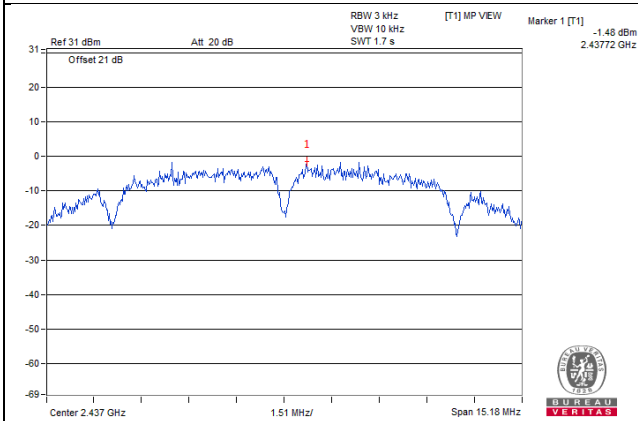

802.11g / Chain 0: CH6

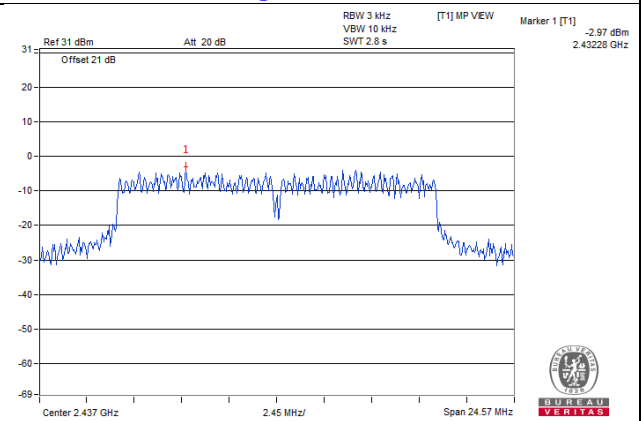

802.11n (HT20) / Chain 0: CH6

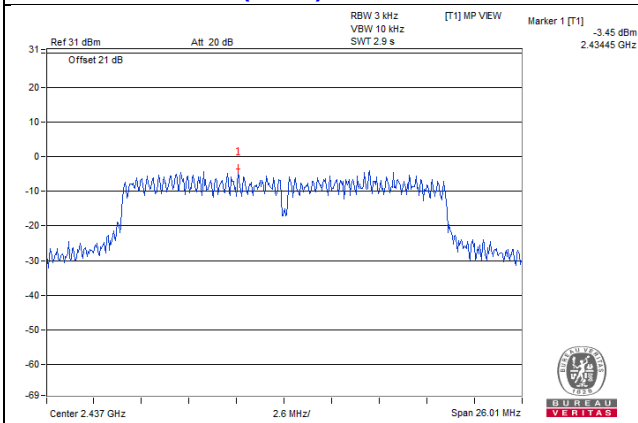

802.11n (HT40) / Chain 1: CH6

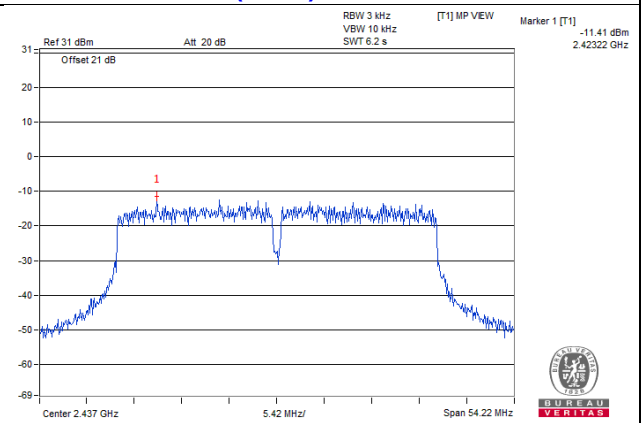

## 4.7 Conducted Out of Band Emission Measurement

### 4.7.1 Limits of Conducted Out of Band Emission Measurement

Below -20dB of the highest emission level of operating band (in 100kHz Resolution Bandwidth).

### 4.7.2 Test Setup

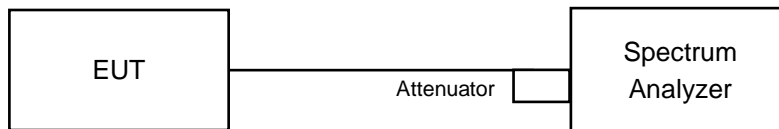

### 4.7.3 Test Instruments

Refer to section 4.1.2 to get information of above instrument.

### 4.7.4 Test Procedure

#### MEASUREMENT PROCEDURE REF

1. Set the RBW = 100 kHz.
2. Set the VBW  $\geq$  300 kHz.
3. Detector = peak.
4. Sweep time = auto couple.
5. Trace mode = max hold.
6. Allow trace to fully stabilize.
7. Use the peak marker function to determine the maximum power level in any 100 kHz band segment within the fundamental EBW.

#### MEASUREMENT PROCEDURE OOBE

1. Set RBW = 100 kHz.
2. Set VBW  $\geq$  300 kHz.
3. Detector = peak.
4. Sweep = auto couple.
5. Trace Mode = max hold.
6. Allow trace to fully stabilize.
7. Use the peak marker function to determine the maximum amplitude level.

### 4.7.5 Deviation from Test Standard

No deviation.

### 4.7.6 EUT Operating Condition

Same as Item 4.3.6

### 4.7.7 Test Results

The spectrum plots are attached on the following pages. D1 line indicates the highest level, and D2 line indicates the 20dB offset below D1. It shows compliance with the requirement.

802.11b  
Chain 0

CH 1

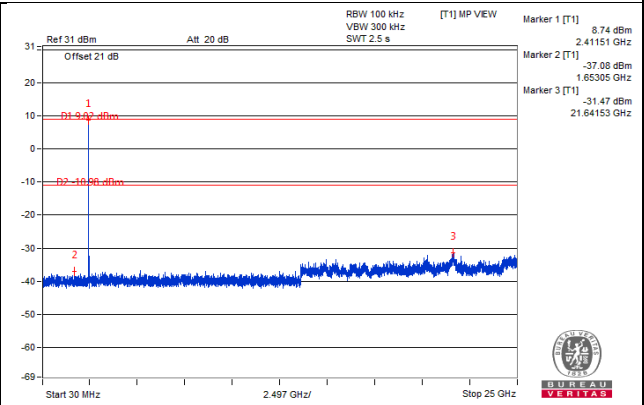
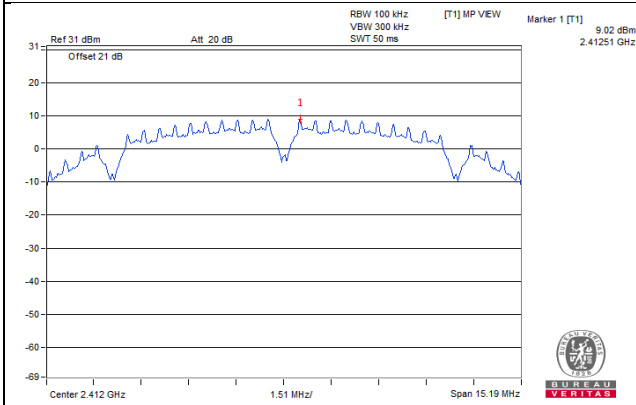

CH 6

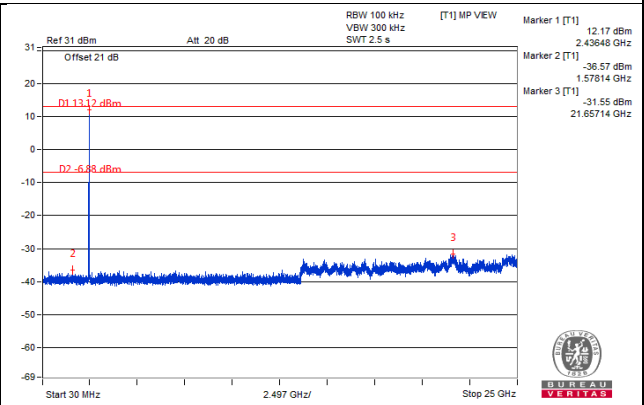
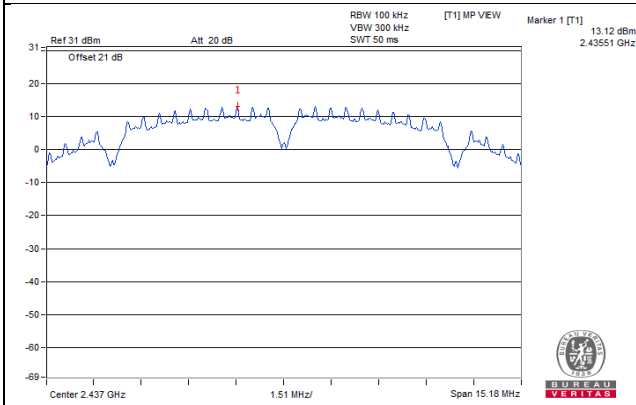

CH 11

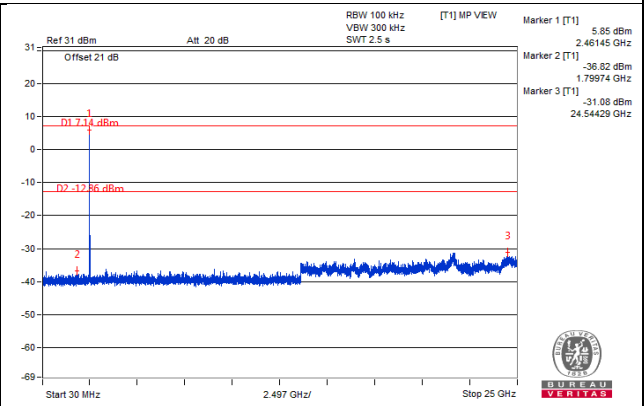
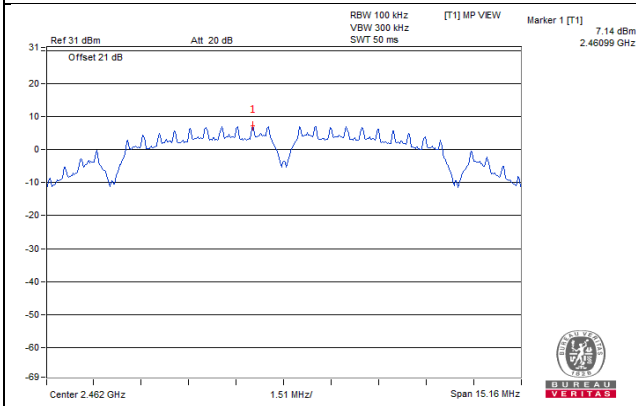

CH 1 Band edge

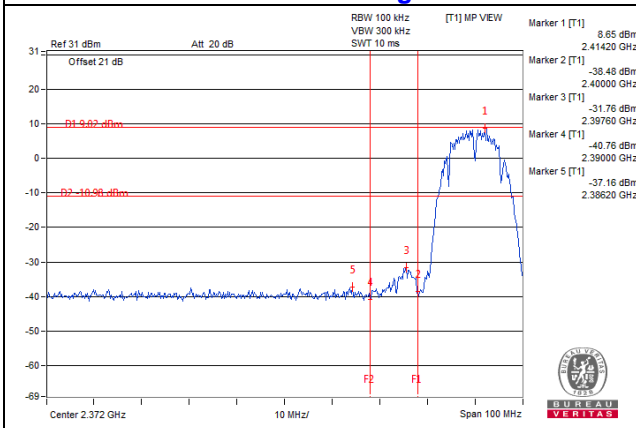

CH 11 Band edge

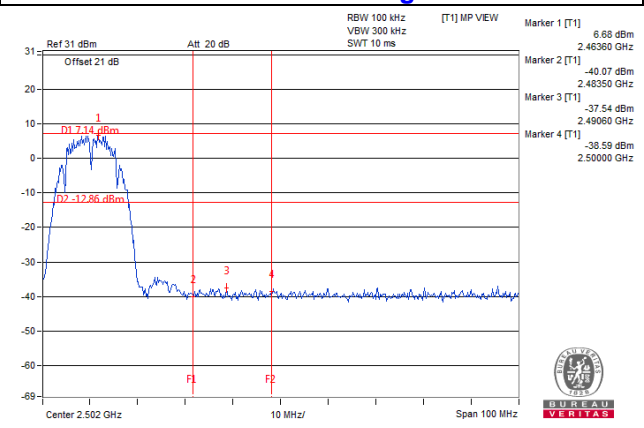

### Chain 1

#### CH 1

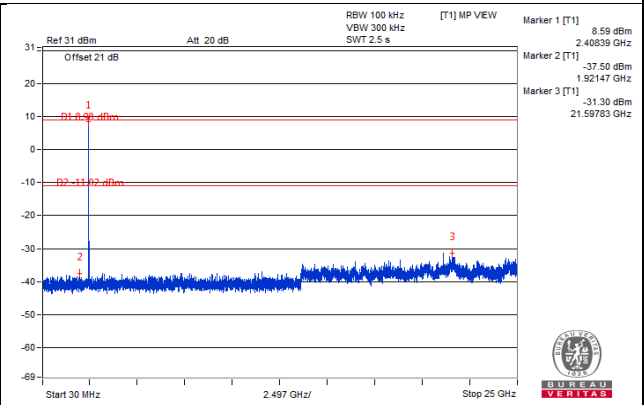
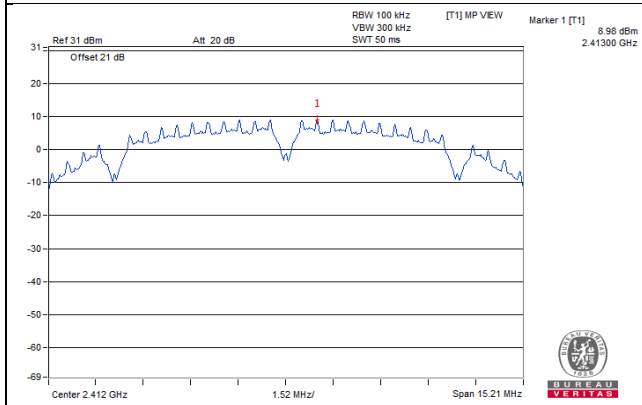

#### CH 6

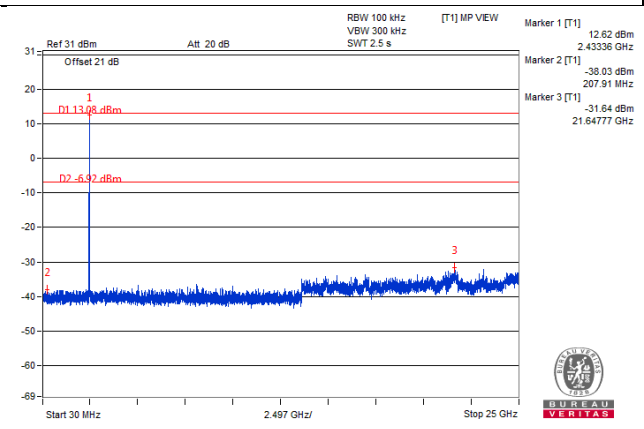
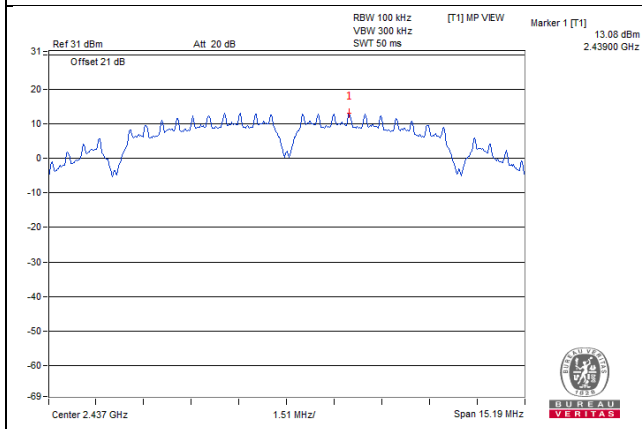

#### CH 11

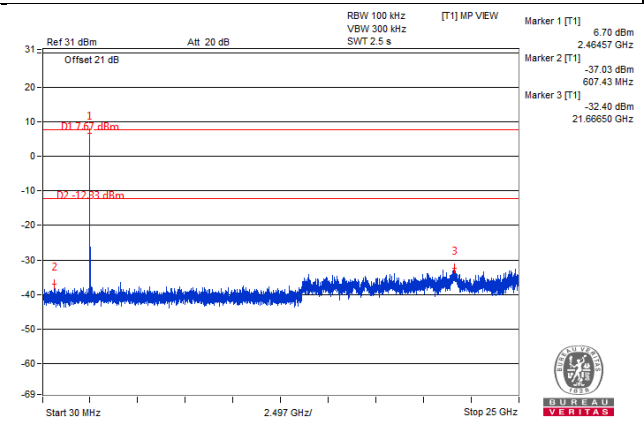
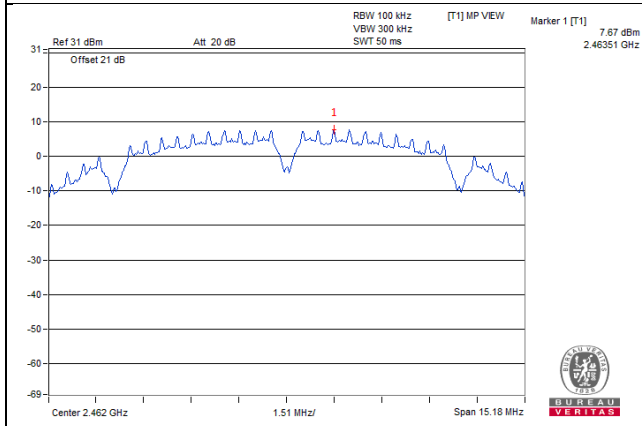

#### CH 1 Band edge

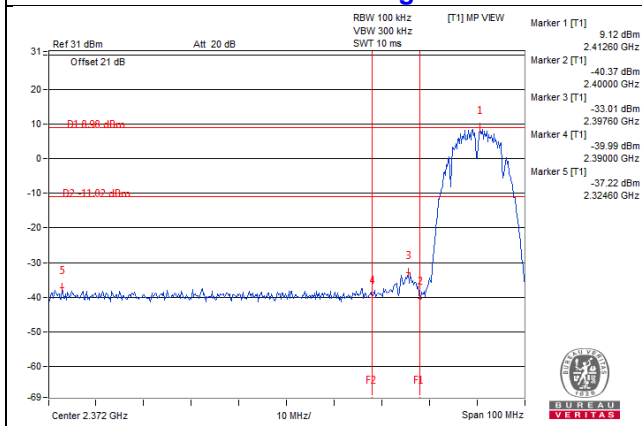

#### CH 11 Band edge

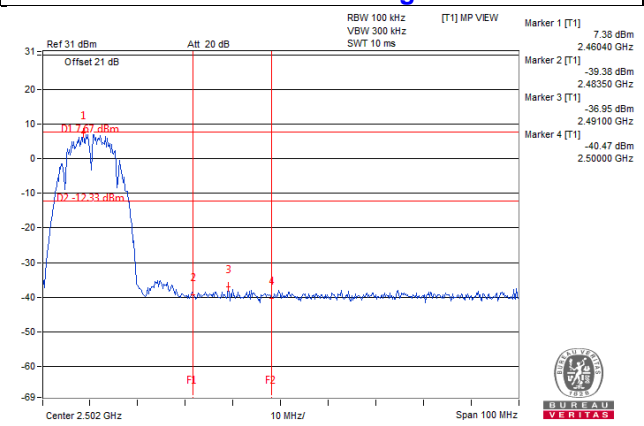

802.11g  
Chain 0

CH 1

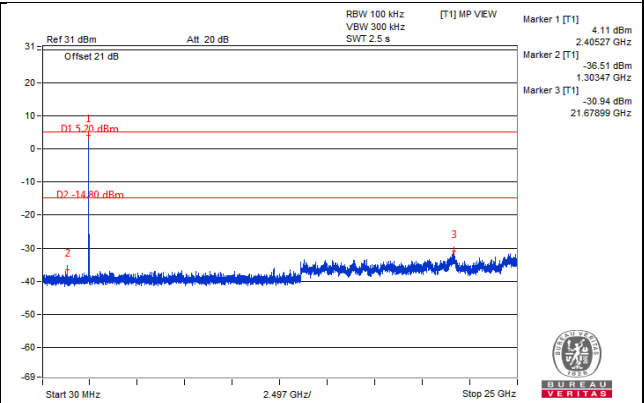
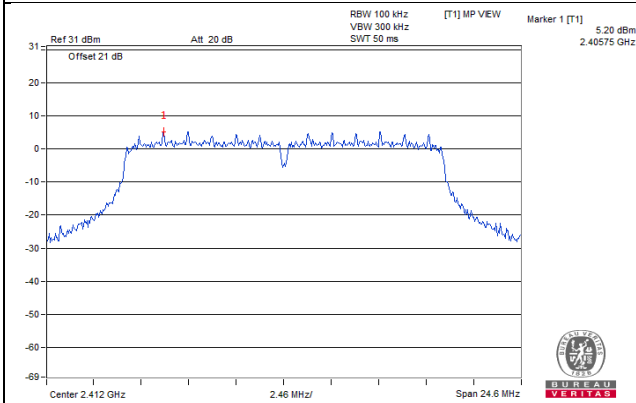

CH 6

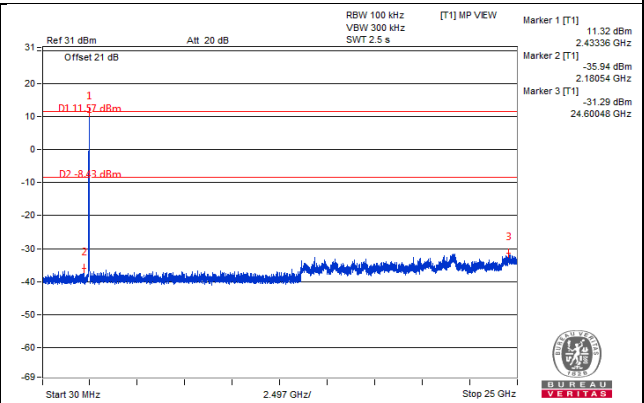
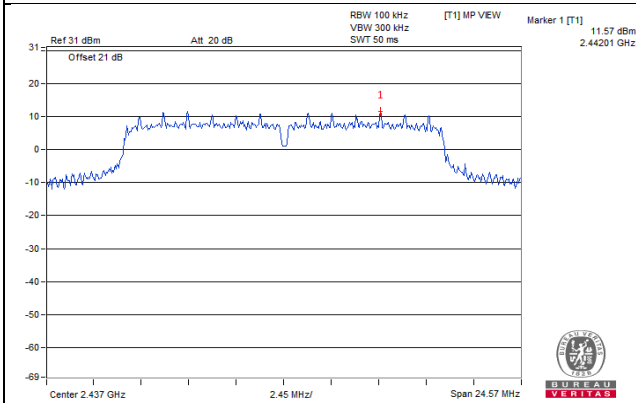

CH 11

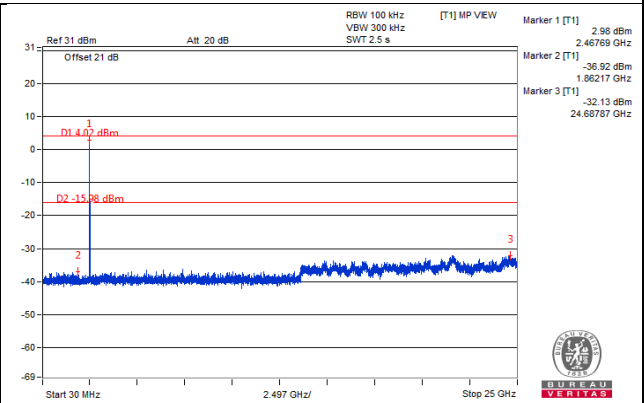
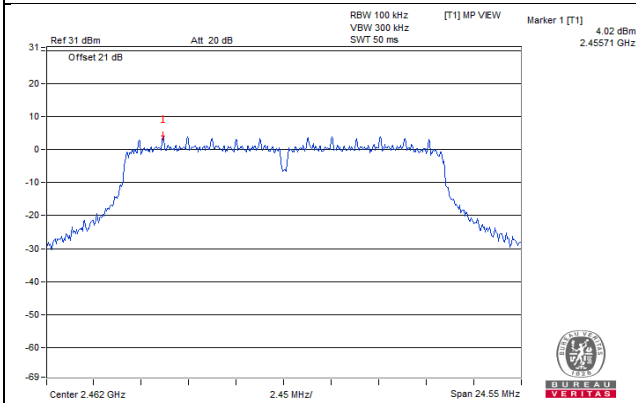

CH 1 Band edge

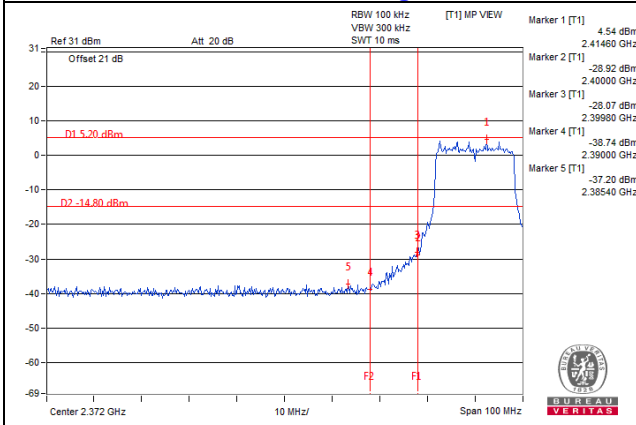

CH 11 Band edge

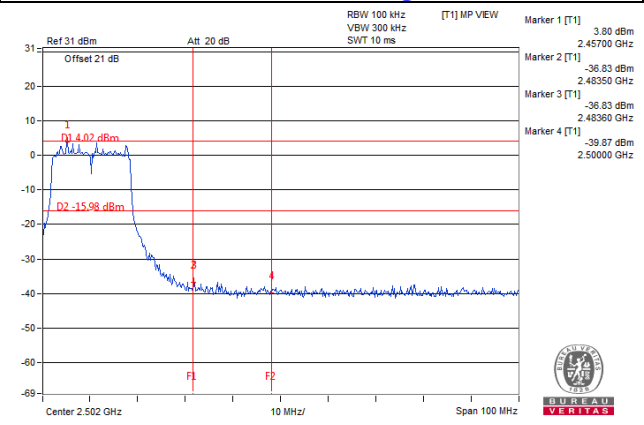



Chain 1

CH 1

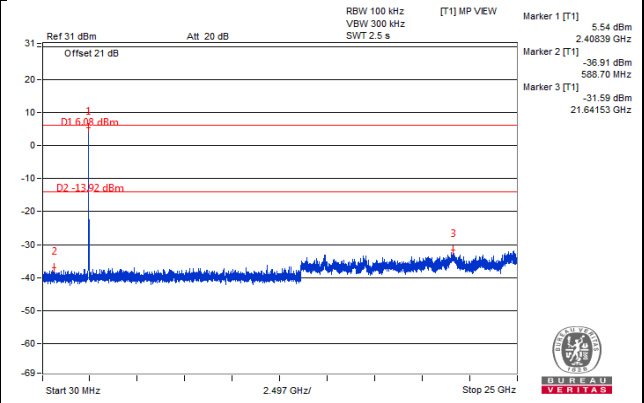
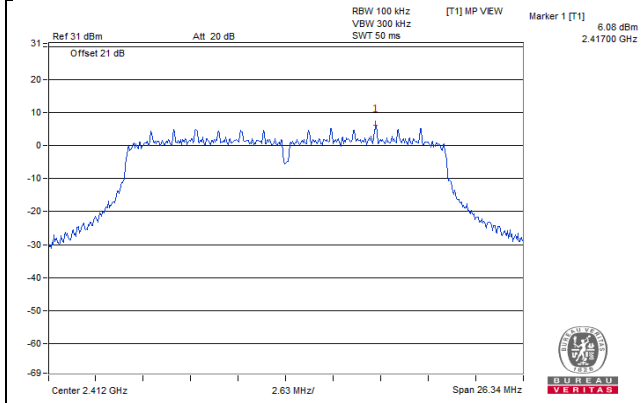

CH 6

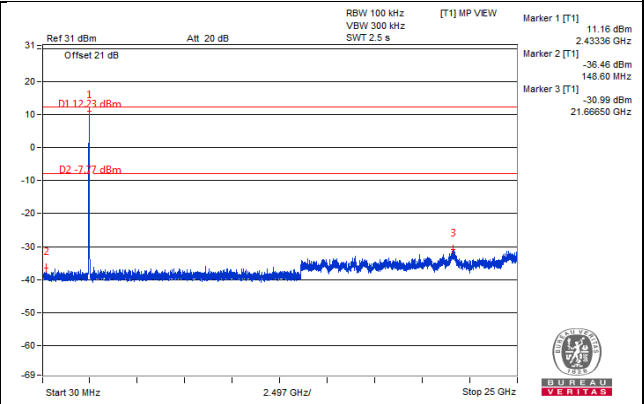
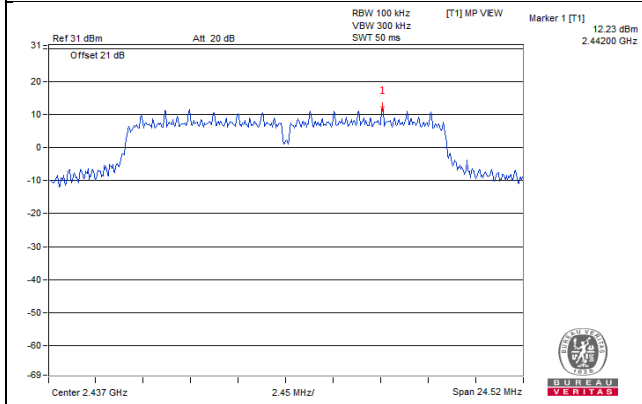

CH 11

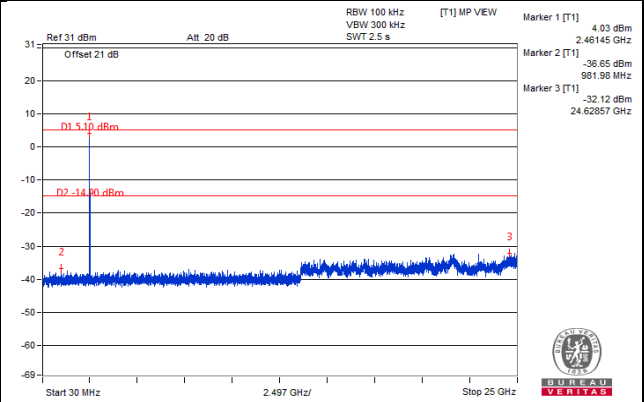
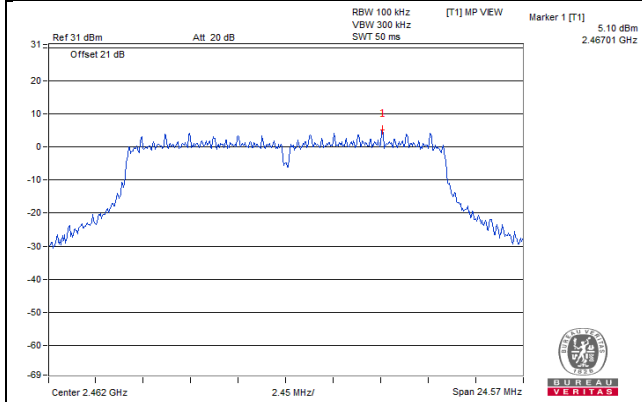

CH 1 Band edge

CH 11 Band edge

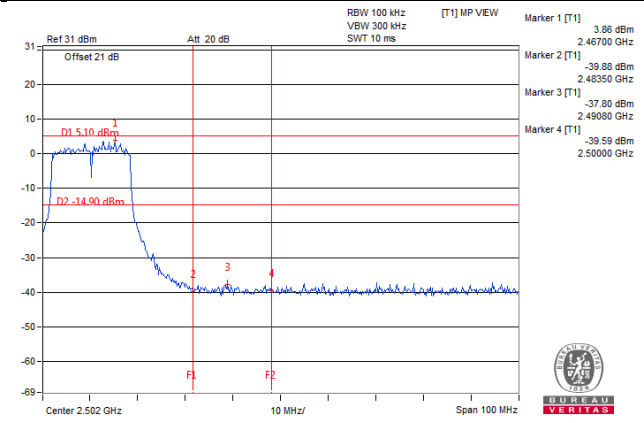
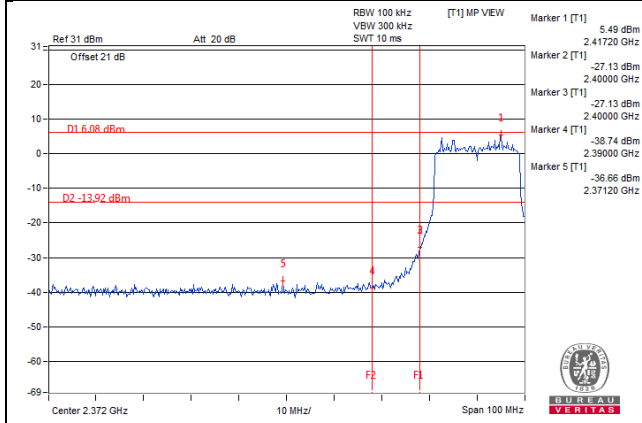

# 802.11n (HT20) Chain 0

## CH 1

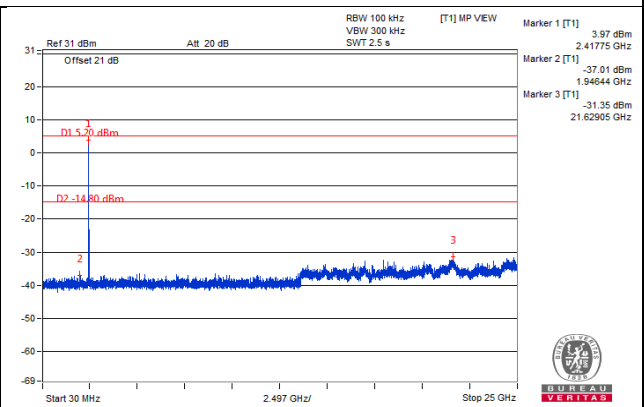
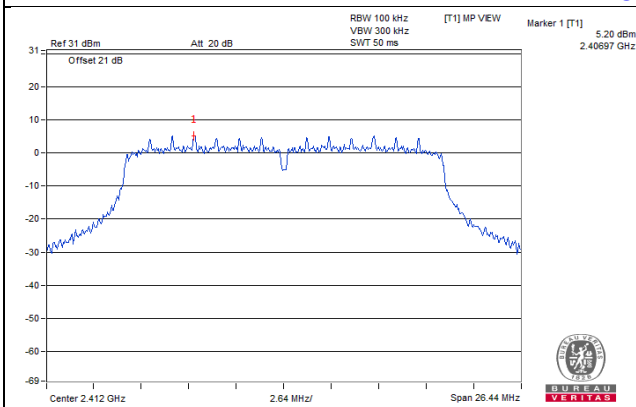

## CH 6

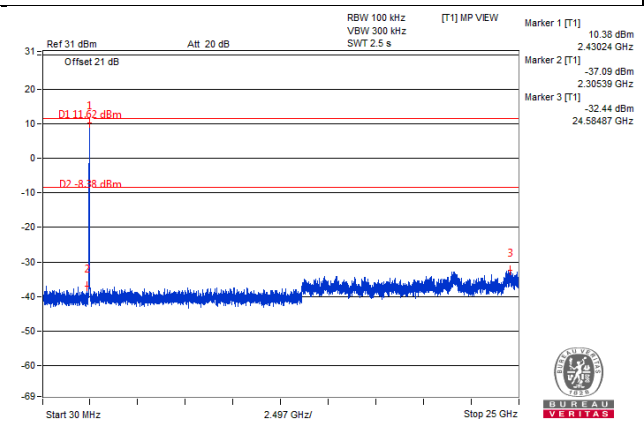
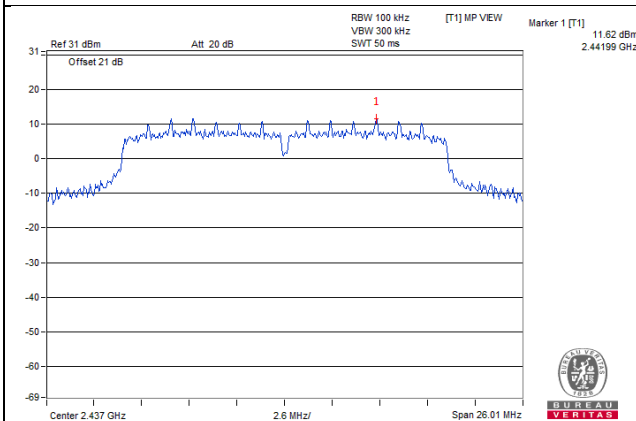

## CH 11

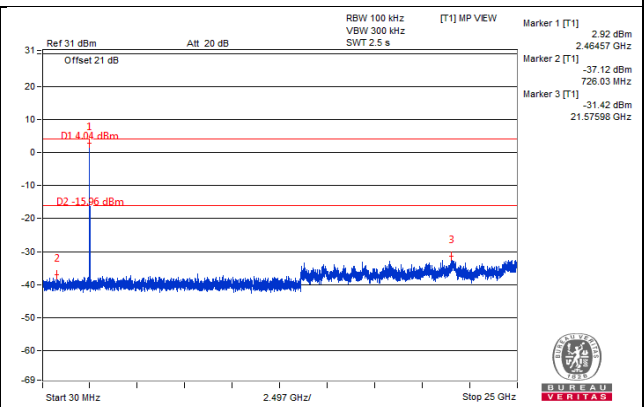
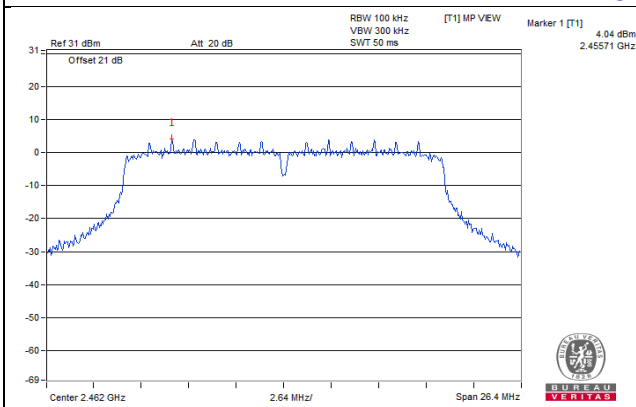

## CH 1 Band edge

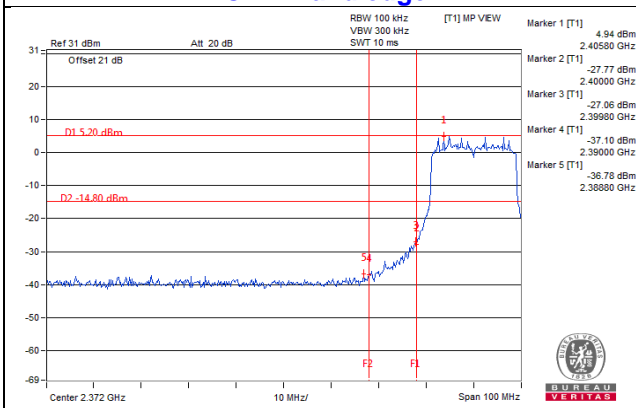

## CH 11 Band edge

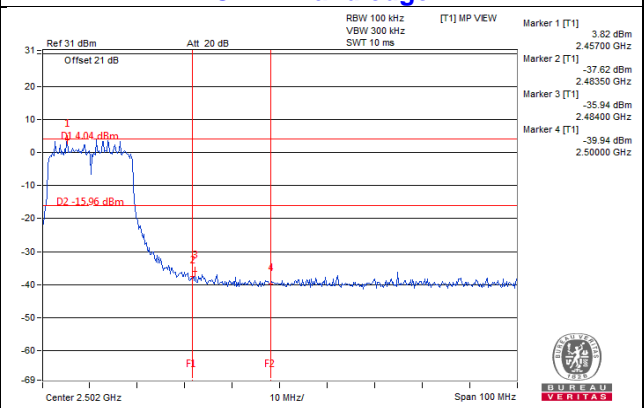

### Chain 1

#### CH 1

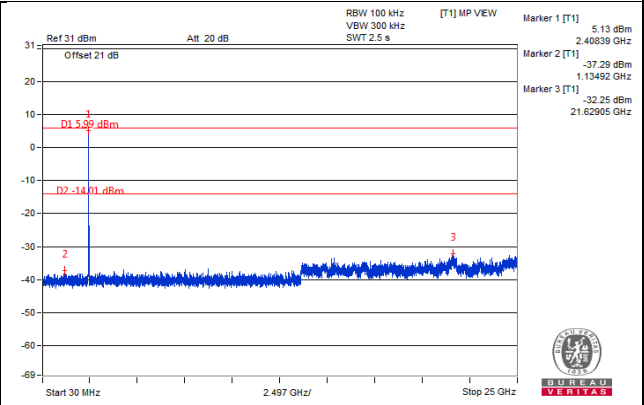
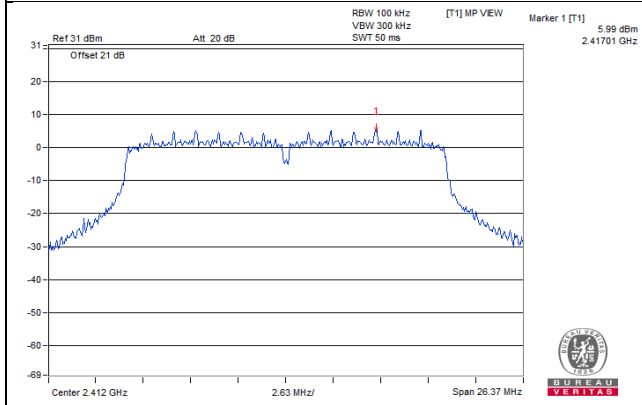

#### CH 6

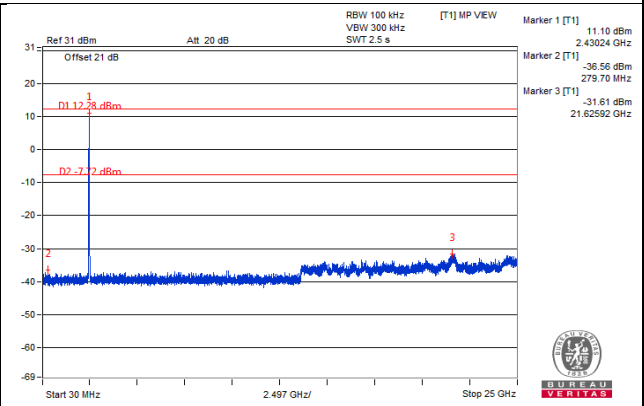
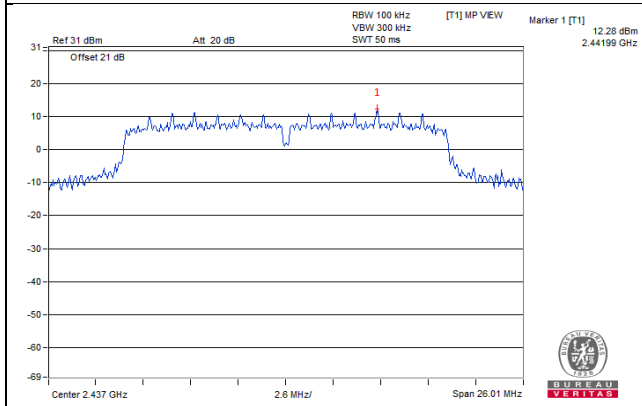

#### CH 11

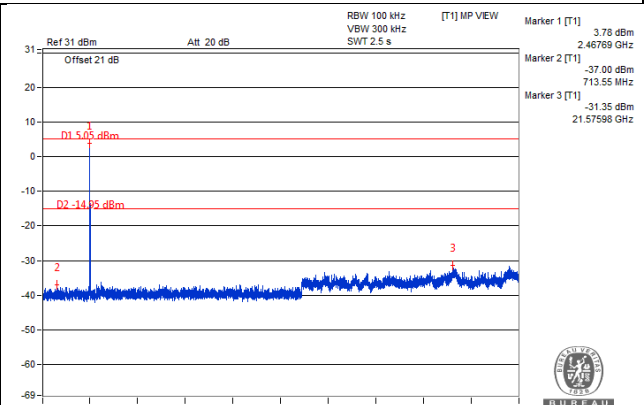
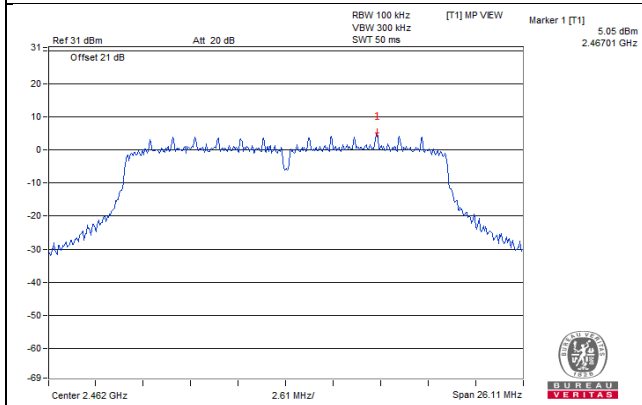

#### CH 1 Band edge

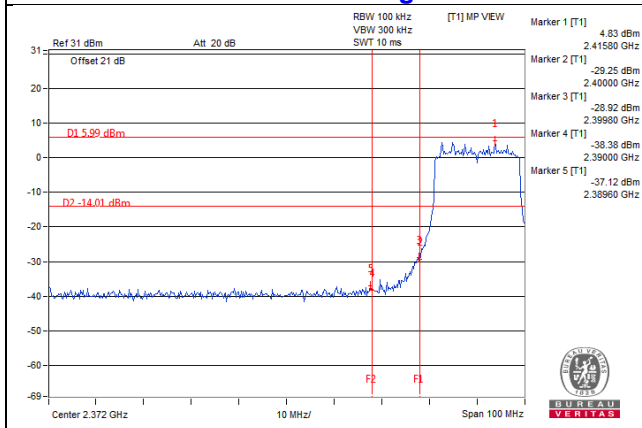

#### CH 11 Band edge

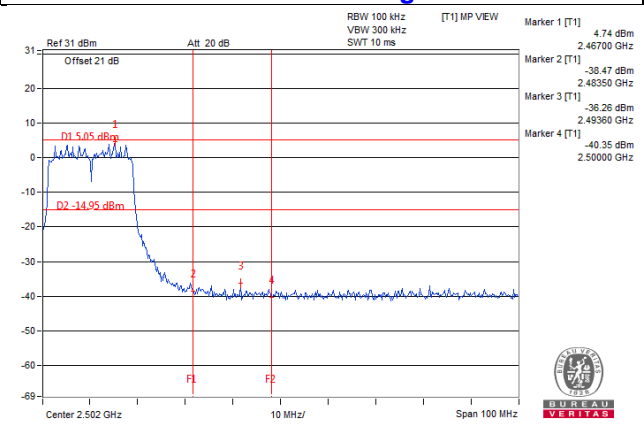

802.11n (HT40)  
Chain 0

CH 3

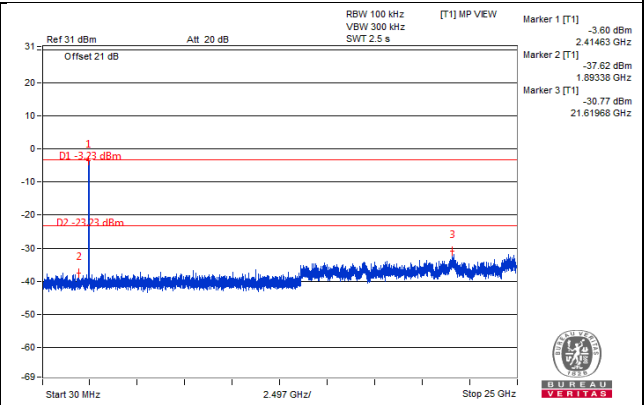
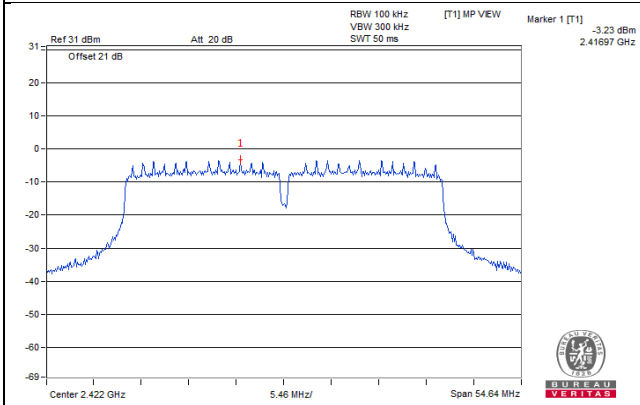

CH 6

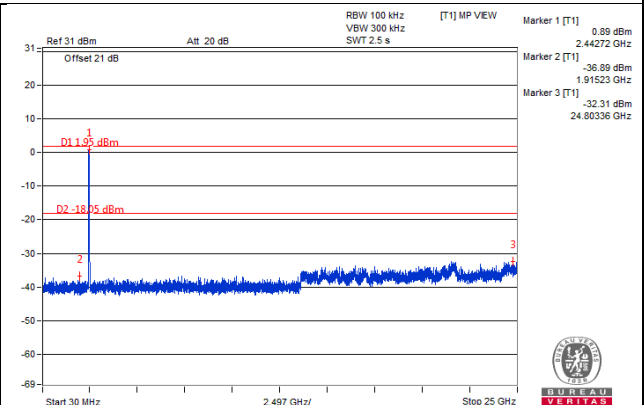
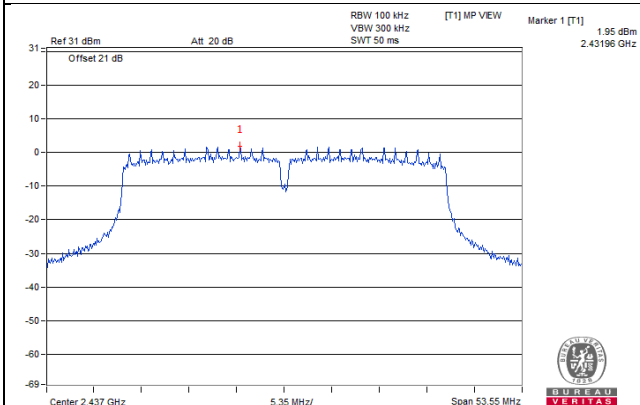

CH 9

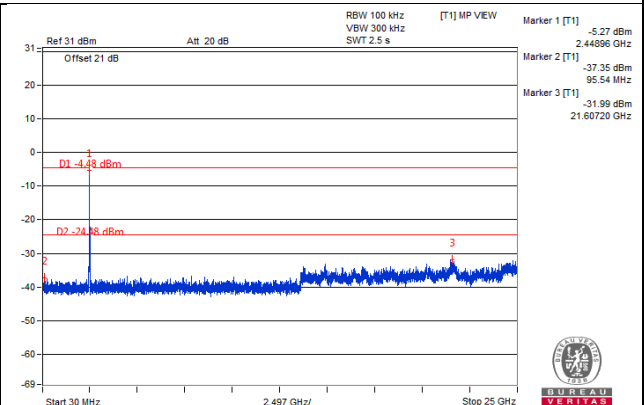
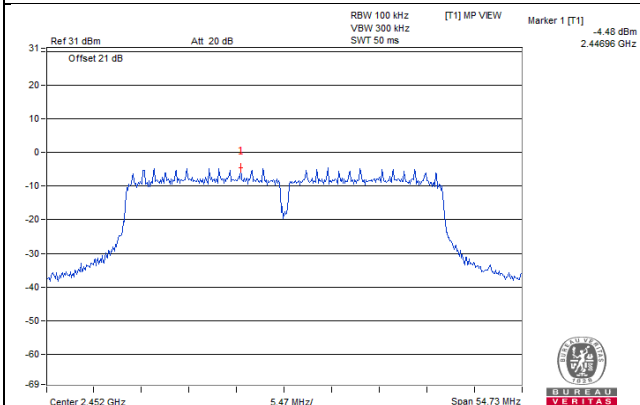

CH 3 Band edge

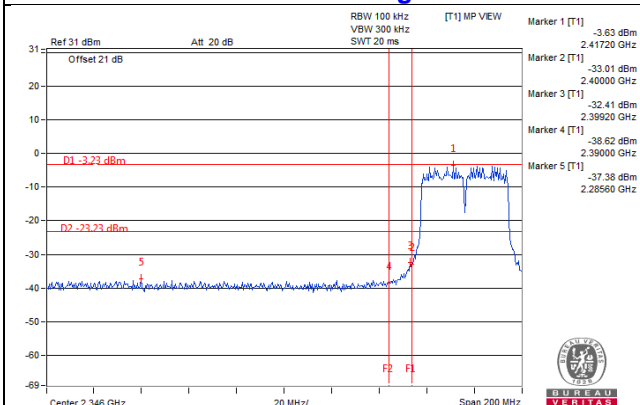

CH 9 Band edge

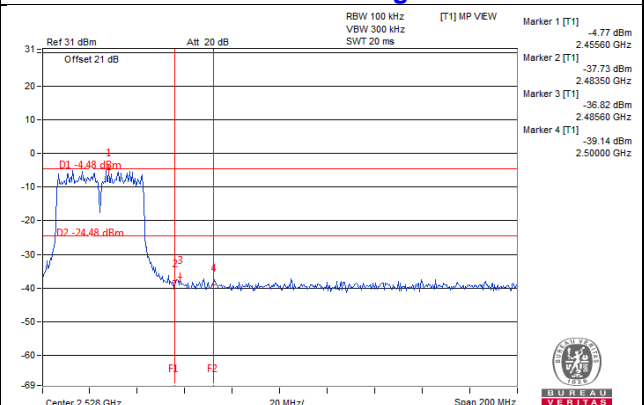

Chain 1

CH 3

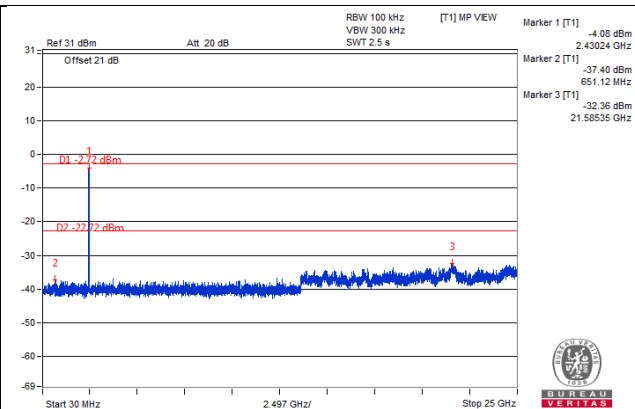
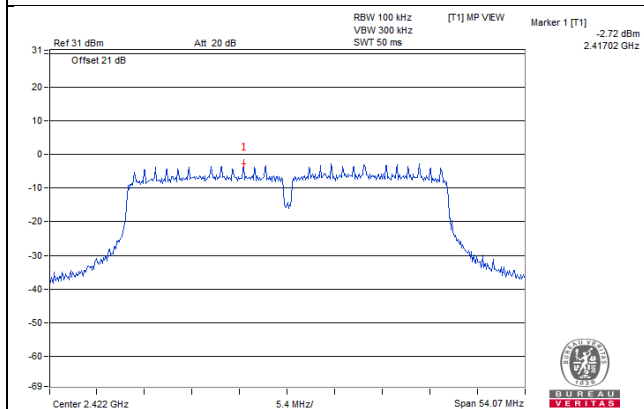

CH 6

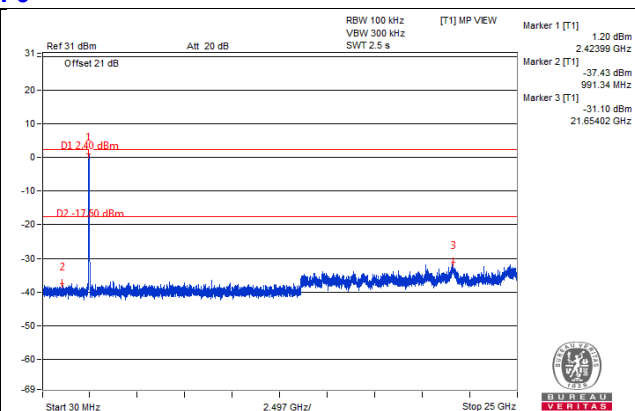
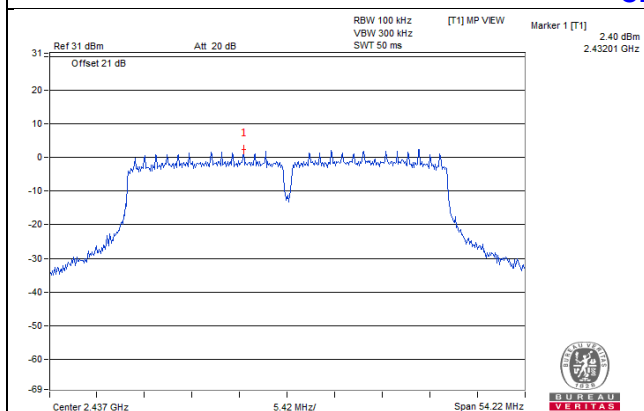

CH 9

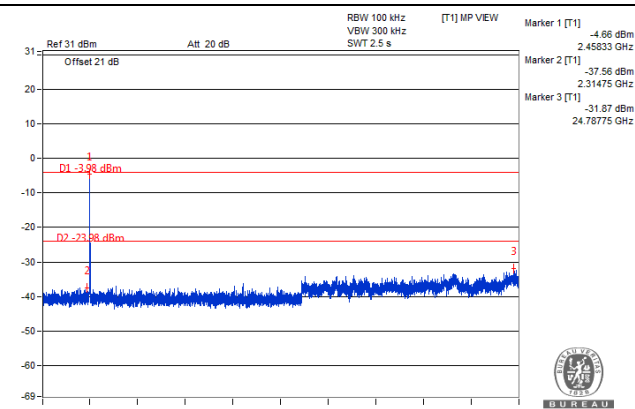
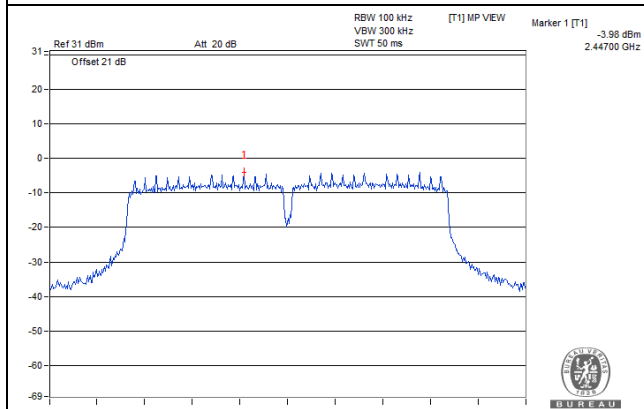

CH 3 Band edge

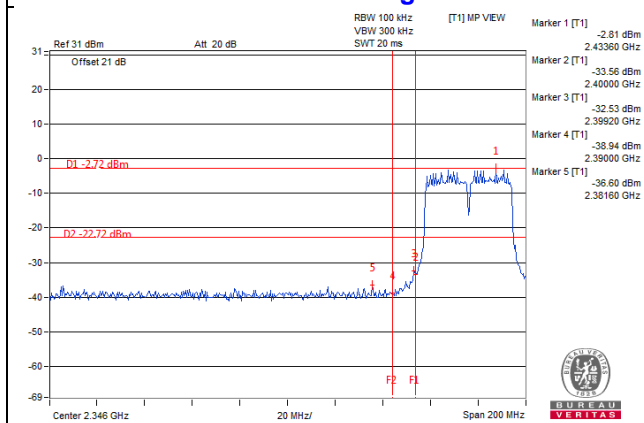

CH 9 Band edge

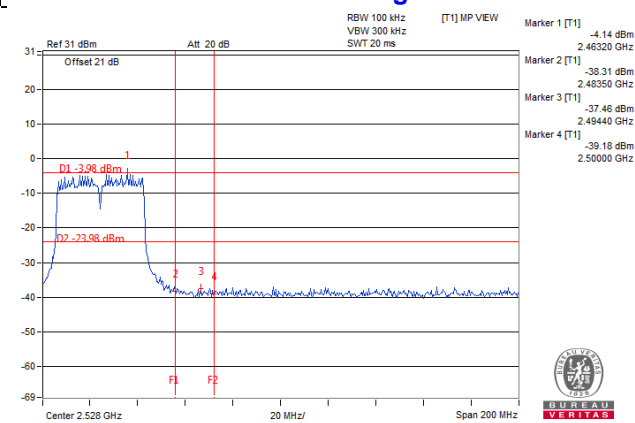

## 5 Pictures of Test Arrangements

Please refer to the attached file (Test Setup Photo).

## Appendix – Information of the Testing Laboratories

We, Bureau Veritas Consumer Products Services (H.K.) Ltd., Taoyuan Branch, were founded in 1988 to provide our best service in EMC, Radio, Telecom and Safety consultation. Our laboratories are FCC recognized accredited test firms and accredited according to ISO/IEC 17025.

If you have any comments, please feel free to contact us at the following:

### Linkou EMC/RF Lab

Tel: 886-2-26052180

Fax: 886-2-26051924

### Hsin Chu EMC/RF/Telecom Lab

Tel: 886-3-6668565

Fax: 886-3-6668323

### Hwa Ya EMC/RF/Safety Lab

Tel: 886-3-3183232

Fax: 886-3-3270892

**Email:** [service.adt@tw.bureauveritas.com](mailto:service.adt@tw.bureauveritas.com)

**Web Site:** [www.bureauveritas-adt.com](http://www.bureauveritas-adt.com)

The address and road map of all our labs can be found in our web site also.

--- END ---