



FCC RADIO TEST REPORT

FCC ID : 2AHKM-CGNV5
Equipment : 24X8 P6 DBCC WiFi eMTA
Brand Name : hitron
Model Name : CGNV5
Applicant : Hitron Technologies Inc.
No. 1-8, Li-Hsin 1st Rd. Hsinchu Science Park,
Hsinchu 30078, Taiwan
Manufacturer : Hitron Technologies Inc.
No. 1-8, Li-Hsin 1st Rd. Hsinchu Science Park,
Hsinchu 30078, Taiwan
Standard : 47 CFR FCC Part 15.407

The product was received on Oct. 18, 2019, and testing was started from Oct. 28, 2019 and completed on Nov. 01, 2019. We, SPORTON INTERNATIONAL INC. EMC & Wireless Communications Laboratory, would like to declare that the tested sample has been evaluated in accordance with the procedures given in ANSI C63.10-2013 and shown compliance with the applicable technical standards.

The report must not be used by the client to claim product certification, approval, or endorsement by TAF or any agency of government.

The test results in this report apply exclusively to the tested model / sample. Without written approval of SPORTON INTERNATIONAL INC. EMC & Wireless Communications Laboratory, the test report shall not be reproduced except in full.



Approved by: Sam Chen

SPORTON INTERNATIONAL INC. EMC & Wireless Communications Laboratory

No. 52, Huaya 1st Rd., Guishan Dist., Taoyuan City, Taiwan (R.O.C.)



Table of Contents

History of this test report.....3

Summary of Test Result.....4

1 General Description5

1.1 Information.....5

1.2 Applicable Standards7

1.3 Testing Location Information7

1.4 Measurement Uncertainty7

2 Test Configuration of EUT8

2.1 Test Channel Mode8

2.2 The Worst Case Measurement Configuration9

2.3 EUT Operation during Test10

2.4 Accessories10

2.5 Support Equipment.....11

2.6 Test Setup Diagram12

3 Transmitter Test Result15

3.1 AC Power-line Conducted Emissions15

3.2 Emission Bandwidth17

3.3 Maximum Conducted Output Power18

3.4 Peak Power Spectral Density.....20

3.5 Unwanted Emissions.....23

4 Test Equipment and Calibration Data27

Appendix A. Test Results of AC Power-line Conducted Emissions

Appendix B. Test Results of Emission Bandwidth

Appendix C. Test Results of Maximum Conducted Output Power

Appendix D. Test Results of Peak Power Spectral Density

Appendix E. Test Results of Unwanted Emissions

Appendix F. Test Results of Radiated Emission Co-location

Appendix G. Test Photos

Photographs of EUT v01



History of this test report

Report No.	Version	Description	Issued Date
FR9O1614AB	01	Initial issue of report	Nov. 13, 2019



Summary of Test Result

Report Clause	Ref Std. Clause	Test Items	Result (PASS/FAIL)	Remark
1.1.2	15.203	Antenna Requirement	PASS	-
3.1	15.207	AC Power-line Conducted Emissions	PASS	-
3.2	15.407(a)	Emission Bandwidth	PASS	-
3.3	15.407(a)	Maximum Conducted Output Power	PASS	-
3.4	15.407(a)	Peak Power Spectral Density	PASS	-
3.5	15.407(b)	Unwanted Emissions	PASS	-

Declaration of Conformity:

The test results with all measurement uncertainty excluded are presented in accordance with the regulation limits or requirements declared by manufacturers.

Comments and Explanations:

The declared of product specification for EUT presented in the report are provided by the manufacturer, and the manufacturer takes all the responsibilities for the accuracy of product specification.

Reviewed by: Sam Chen

Report Producer: Cindy Peng



1 General Description

1.1 Information

1.1.1 RF General Information

Frequency Range (MHz)	IEEE Std. 802.11	Ch. Frequency (MHz)	Channel Number
5150-5250	a, n (HT20), ac (VHT20)	5180-5240	36-48 [4]
5725-5850		5745-5825	149-165 [5]
5150-5250	n (HT40), ac (VHT40)	5190-5230	38-46 [2]
5725-5850		5755-5795	151-159 [2]
5150-5250	ac (VHT80)	5210	42 [1]
5725-5850		5775	155 [1]

Band	Mode	BWch (MHz)	Nant
5.15-5.25GHz	802.11a	20	3TX
5.15-5.25GHz	802.11n HT20	20	3TX
5.15-5.25GHz	802.11ac VHT20	20	3TX
5.15-5.25GHz	802.11n HT40	40	3TX
5.15-5.25GHz	802.11ac VHT40	40	3TX
5.15-5.25GHz	802.11ac VHT80	80	3TX
5.725-5.85GHz	802.11a	20	3TX
5.725-5.85GHz	802.11n HT20	20	3TX
5.725-5.85GHz	802.11ac VHT20	20	3TX
5.725-5.85GHz	802.11n HT40	40	3TX
5.725-5.85GHz	802.11ac VHT40	40	3TX
5.725-5.85GHz	802.11ac VHT80	80	3TX

Note:

- ♦ 11a, HT20 and HT40 use a combination of OFDM-BPSK, QPSK, 16QAM, 64QAM modulation.
- ♦ VHT20, VHT40 and VHT80 use a combination of OFDM-BPSK, QPSK, 16QAM, 64QAM, 256QAM modulation.
- ♦ BWch is the nominal channel bandwidth.
- ♦ Nss-Min is the minimum number of spatial streams.
- ♦ Nant is the number of outputs. e.g., 2(2,3) means have 2 outputs for port 2 and port 3. 2 means have 2 outputs for port 1 and port 2.



1.1.2 Antenna Information

Ant.	Port		Brand	Model Name	Type	Connector	Gain (dBi)	
	2.4GHz	5GHz					2.4GHz	5GHz
1	1	2	LYNWAVE	ALX19P-221AA1-00	Dipole	I-PEX	2.5	3.4
2	2	3	LYNWAVE	ALX19P-221AA2-00	Dipole	I-PEX	2.5	3.4
3	3	-	LYNWAVE	ALX19P-221AA3-00	Dipole	I-PEX	2.5	-
4	-	1	LYNWAVE	ALX19P-221AA0-00	Dipole	I-PEX	-	3.4

Note 1: The above information was declared by manufacturer.

Note 2: The EUT has four antennas.

<For 2.4GHz Band>

For IEEE 802.11b mode (1TX/1RX)

Only Port 1 can be used as transmitting/receiving.

For IEEE 802.11g/n mode (3TX/3RX)

Port 1, Port 2 and Port 3 could transmit/receive simultaneously.

<For 5GHz Band>

For IEEE 802.11a/n/ac mode (3TX/3RX)

Port 1, Port 2 and Port 3 could transmit/receive simultaneously.

1.1.3 Mode Test Duty Cycle

Mode	DC	DCF(dB)	T(s)	VBW(Hz) ≥ 1/T
802.11a	1	0	n/a (DC>=0.98)	n/a (DC>=0.98)
802.11ac VHT20	1	0	n/a (DC>=0.98)	n/a (DC>=0.98)
802.11ac VHT40	1	0	n/a (DC>=0.98)	n/a (DC>=0.98)
802.11ac VHT80	1	0	n/a (DC>=0.98)	n/a (DC>=0.98)

Note:

- ◆ DC is Duty Cycle.
- ◆ DCF is Duty Cycle Factor.

1.1.4 EUT Operational Condition

EUT Power Type	From power adapter			
Beamforming Function	<input type="checkbox"/>	With beamforming	<input checked="" type="checkbox"/>	Without beamforming
Function	<input type="checkbox"/>	Outdoor P2M	<input checked="" type="checkbox"/>	Indoor P2M
	<input type="checkbox"/>	Fixed P2P	<input type="checkbox"/>	Client
Test Software Version	Lantiq DUT、Telnet			

Note: The above information was declared by manufacturer.



1.2 Applicable Standards

According to the specifications of the manufacturer, the EUT must comply with the requirements of the following standards:

- ◆ 47 CFR FCC Part 15
- ◆ ANSI C63.10-2013
- ◆ FCC KDB 789033 D02 v02r01
- ◆ FCC KDB 662911 D01 v02r01
- ◆ FCC KDB 412172 D01 v01r01
- ◆ FCC KDB 414788 D01 v01r01

1.3 Testing Location Information

Testing Location		
<input type="checkbox"/>	HWA YA	ADD : No. 52, Huaya 1st Rd., Guishan Dist., Taoyuan City, Taiwan (R.O.C.) TEL : 886-3-327-3456 FAX : 886-3-327-0973
<input checked="" type="checkbox"/>	JHUBEI	ADD : No.8, Lane 724, Bo-ai St., Jhubei City, HsinChu County 302, Taiwan, R.O.C. TEL : 886-3-656-9065 FAX : 886-3-656-9085

Test Condition	Test Site No.	Test Engineer	Test Environment	Test Date
RF Conducted	TH02-CB	Ekko Hsieh	24.2~24.6°C / 58~62%	Oct. 31, 2019~Nov. 01, 2019
Radiated below 1GHz	03CH05-CB	Bruce Yang	23.6~25.1°C / 60~64%	Oct. 28, 2019
Radiated above 1GHz	03CH06-CB	Stim Sung	23.7~25.9°C / 59~61%	Oct. 30, 2019~Oct. 31, 2019
AC Conduction	CO01-CB	Ryo Fan	24~26°C / 67~60%	Nov. 01, 2019

Test site Designation No. TW0006 with FCC
Test site registered number IC 4086D with Industry Canada.

1.4 Measurement Uncertainty

ISO/IEC 17025 requires that an estimate of the measurement uncertainties associated with the emissions test results be included in the report. The measurement uncertainties given below are based on a 95% confidence level (based on a coverage factor (k=2))

Test Items	Uncertainty	Remark
Conducted Emission (150kHz ~ 30MHz)	2.0 dB	Confidence levels of 95%
Radiated Emission (30MHz ~ 1,000MHz)	4.3 dB	Confidence levels of 95%
Radiated Emission (1GHz ~ 18GHz)	4.3 dB	Confidence levels of 95%
Radiated Emission (18GHz ~ 40GHz)	5.1 dB	Confidence levels of 95%
Conducted Emission	2.4 dB	Confidence levels of 95%
Output Power Measurement	1.5 dB	Confidence levels of 95%
Power Density Measurement	2.4 dB	Confidence levels of 95%
Bandwidth Measurement	2%	Confidence levels of 95%



2 Test Configuration of EUT

2.1 Test Channel Mode

Mode	Power Setting
802.11a_Nss1,(6Mbps)_3TX	-
5180MHz	20.5
5200MHz	31.5
5240MHz	31.5
5745MHz	31.5
5785MHz	31.5
5825MHz	31.5
802.11ac VHT20_Nss1,(MCS0)_3TX	-
5180MHz	20
5200MHz	31.5
5240MHz	31.5
5745MHz	31.5
5785MHz	31.5
5825MHz	31.5
802.11ac VHT40_Nss1,(MCS0)_3TX	-
5190MHz	18
5230MHz	31.5
5755MHz	31.5
5795MHz	31.5
802.11ac VHT80_Nss1,(MCS0)_3TX	-
5210MHz	17.5
5775MHz	31.5

Note:

- ♦ VHT20/VHT40 covers HT20/HT40, due to same modulation. The power setting for 802.11n HT20 and HT40 are the same or lower than 802.11ac VHT20 and VHT40.



2.2 The Worst Case Measurement Configuration

The Worst Case Mode for Following Conformance Tests	
Tests Item	AC power-line conducted emissions
Condition	AC power-line conducted measurement for line and neutral
Operating Mode	Normal Link
1	EUT + Adapter 1
2	EUT + Adapter 2
For operating mode 2 is the worst case and it was record in this test report.	

The Worst Case Mode for Following Conformance Tests	
Tests Item	Emission Bandwidth Maximum Conducted Output Power Peak Power Spectral Density
Test Condition	Conducted measurement at transmit chains

The Worst Case Mode for Following Conformance Tests	
Tests Item	Unwanted Emissions
Test Condition	Radiated measurement If EUT consist of multiple antenna assembly (multiple antenna are used in EUT regardless of spatial multiplexing MIMO configuration), the radiated test should be performed with highest antenna gain of each antenna type.
Operating Mode < 1GHz	Normal Link
1	EUT + Adapter 1
2	EUT + Adapter 2
For operating mode 1 is the worst case and it was record in this test report.	
Operating Mode > 1GHz	CTX

The Worst Case Mode for Following Conformance Tests	
Tests Item	Simultaneous Transmission Analysis - Radiated Emission Co-location
Test Condition	Radiated measurement
Operating Mode	Normal Link
1	WLAN 2.4GHz + WLAN 5GHz
Refer to Appendix F for Radiated Emission Co-location.	



The Worst Case Mode for Following Conformance Tests	
Tests Item	Simultaneous Transmission Analysis - Co-location RF Exposure Evaluation
Operating Mode	
1	WLAN 2.4GHz + WLAN 5GHz
Refer to Sporton Test Report No.: FA901614 for Co-location RF Exposure Evaluation.	

Note: The EUT can only be used at Y axis position.

2.3 EUT Operation during Test

For CTX Mode:

The EUT was programmed to be in continuously transmitting mode.

For Normal Link:

During the test, the EUT operation to normal function.

2.4 Accessories

Accessories				
No.	Equipment Name	Brand Name	Model Name	Rating
1	Adapter 1	APD	WA-30P12FU	Input: 100-240V~50-60Hz, 0.9A Max. Output: 12V, 2.5A
2	Adapter 2	MOSO	MSS-V2500WR120-030E0-US	Input: 100-240V~50/60Hz, 1.0A max. Output: 12.0V, 2.5A
No.	Other			
3	RJ-45 cable*1: Non-shielded, 1.5m			



2.5 Support Equipment

For AC Conduction:

Support Equipment				
No.	Equipment	Brand Name	Model Name	FCC ID
A	LAN NB	DELL	E6430	N/A
B	Phone	SAMPO	HT-B 907WL	N/A
C	Terminal System	CASA-Systems	C2200	N/A
D	Terminal System NB	HP	EliteBook 840	N/A
E	Phone	SAMPO	HT-B 907WL	N/A
F	Flash disk3.0	Apacer	AH223	N/A
G	2.4G NB	DELL	E6430	N/A
H	5G NB	DELL	E6430	N/A

For Radiated (below 1GHz):

Support Equipment				
No.	Equipment	Brand Name	Model Name	FCC ID
A	Notebook	DELL	E4300	N/A
B	Notebook	DELL	E4300	N/A
C	Notebook	DELL	E4300	N/A
D	Notebook	Lenovo	TP00093A	N/A
E	Terminal System	CASA-Systems	C2200	N/A
F	Phone	SAMPO	HT-B 907WL	N/A
G	Phone	SAMPO	HT-B 907WL	N/A
H	USB dongle	Apacer	AH223	N/A
I	Notebook	Lenovo	TP00075A	N/A
J	Earphone	e-Power	S90W	N/A
K	Mouse	Logitech	M-U0026	N/A

For Radiated (above 1GHz) and RF Conducted:

Support Equipment				
No.	Equipment	Brand Name	Model Name	FCC ID
A	Notebook	DELL	E4300	N/A

2.6 Test Setup Diagram

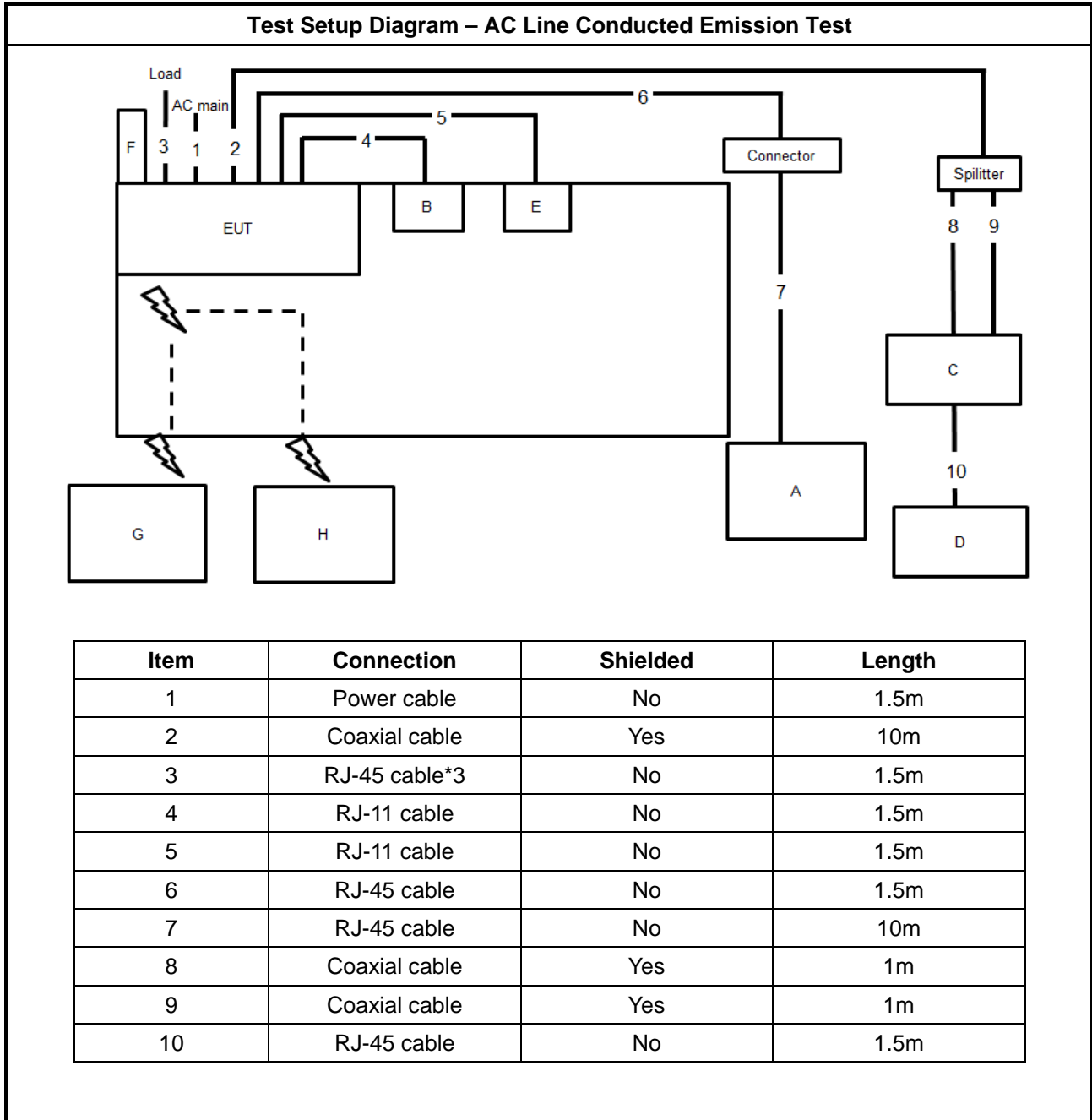



Test Setup Diagram - Radiated Test < 1GHz

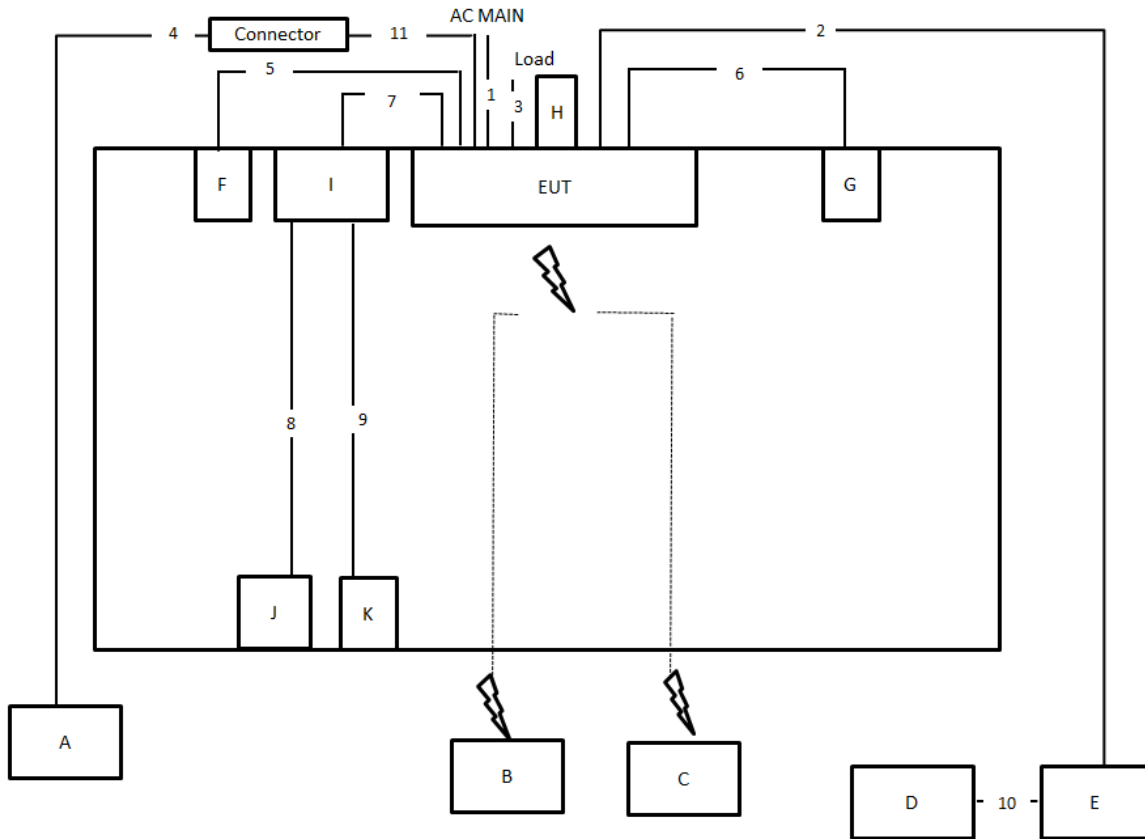

Item	Connection	Shielded	Length
1	Power cable	No	1.5m
2	Coaxial cable	Yes	10m
3	RJ-45 cable*3	No	1.5m
4	RJ-45 cable	No	10m
5	RJ-11 cable	No	1.5m
6	RJ-11 cable	No	1.5m
7	Console cable	No	1.5m
8	USB cable	Yes	1.5m
9	Audio cable	No	1.5m
10	RJ-45 cable	No	1.5m
11	RJ-45 cable	No	1.5m



Test Setup Diagram - Radiated Test > 1GHz

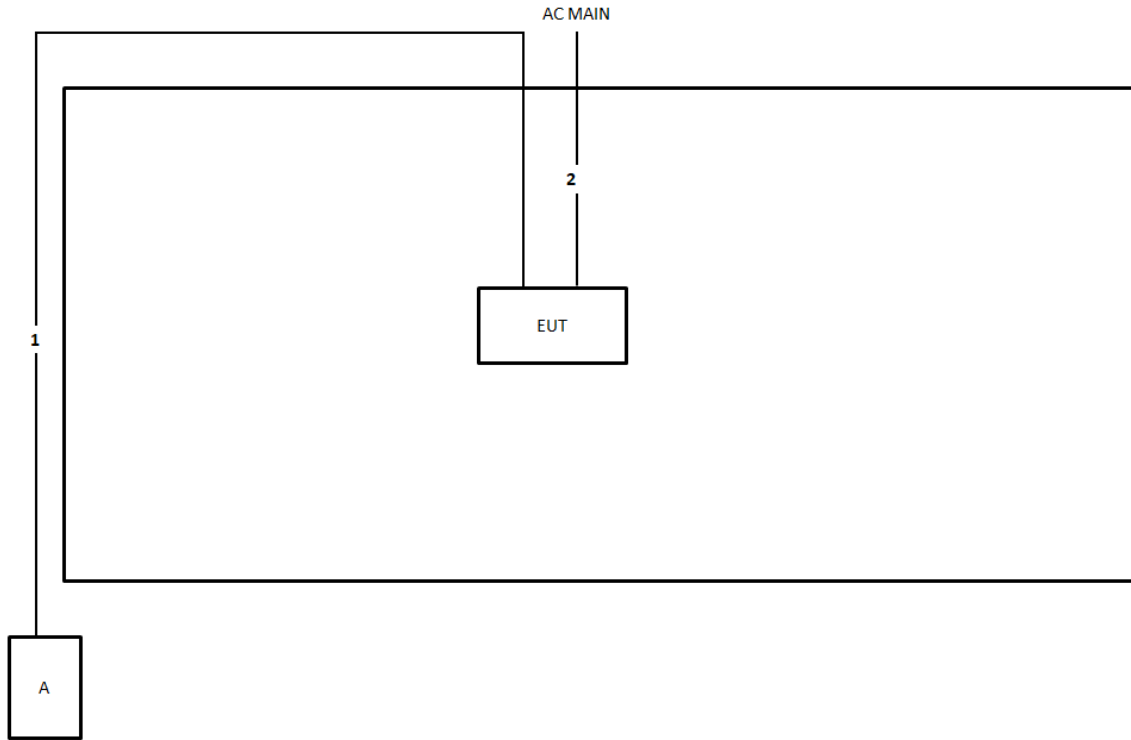

Item	Connection	Shielded	Length
1	RJ-45 cable	No	10m
2	Power cable	No	1.5m



3 Transmitter Test Result

3.1 AC Power-line Conducted Emissions

3.1.1 AC Power-line Conducted Emissions Limit

AC Power-line Conducted Emissions Limit		
Frequency Emission (MHz)	Quasi-Peak	Average
0.15-0.5	66 - 56 *	56 - 46 *
0.5-5	56	46
5-30	60	50

Note 1: * Decreases with the logarithm of the frequency.

3.1.2 Measuring Instruments

Refer a test equipment and calibration data table in this test report.

3.1.3 Test Procedures

Test Method
<input checked="" type="checkbox"/> Refer as ANSI C63.10-2013, clause 6.2 for AC power-line conducted emissions.

3.1.4 Test Setup

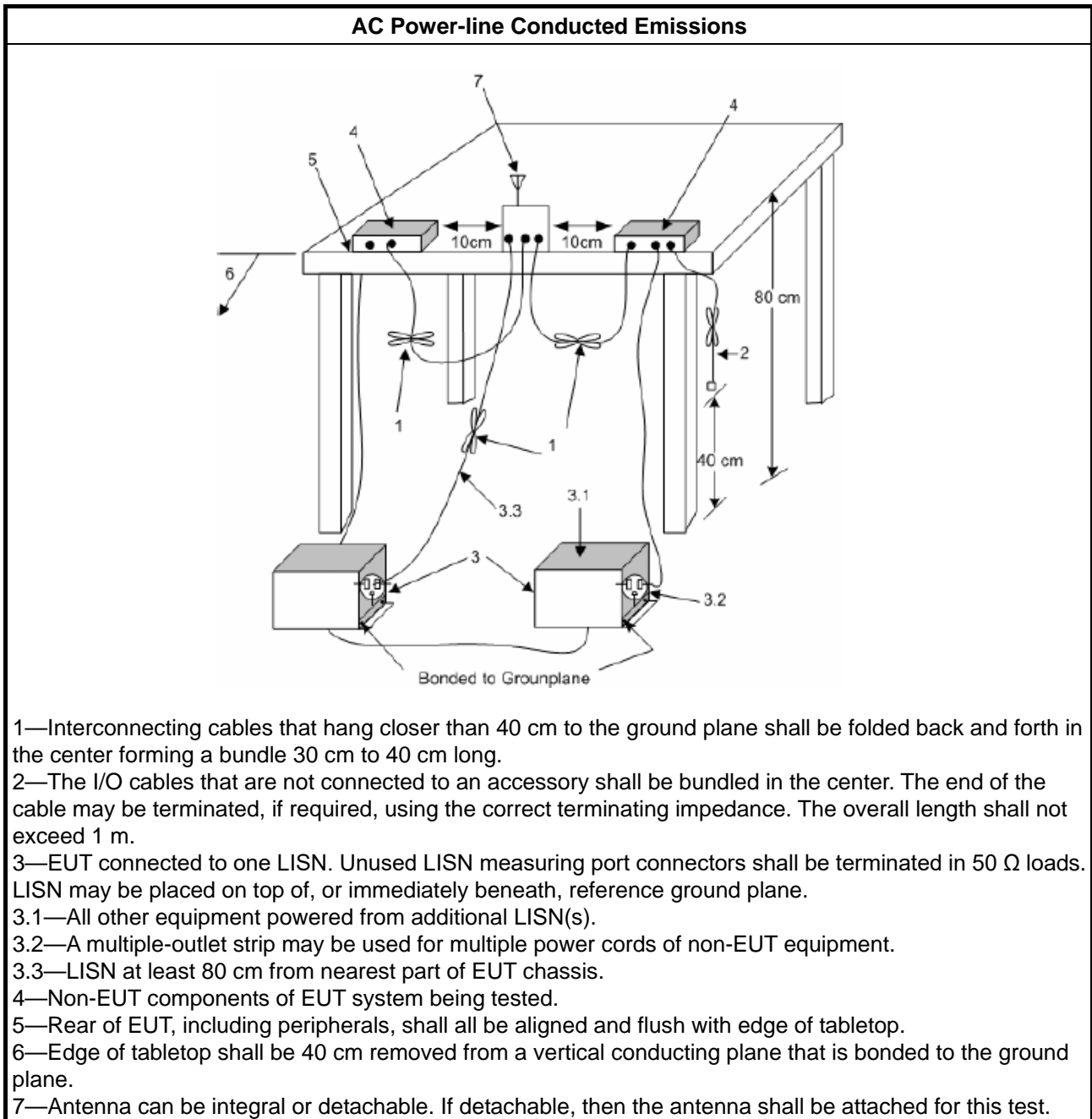

3.1.5 Test Result of AC Power-line Conducted Emissions

Refer as Appendix A

3.2 Emission Bandwidth

3.2.1 Emission Bandwidth Limit

Emission Bandwidth Limit	
UNII Devices	
<input checked="" type="checkbox"/>	For the 5.15-5.25 GHz band, N/A
<input type="checkbox"/>	For the 5.25-5.35 GHz band, the maximum conducted output power shall not exceed the lesser of 250 mW or 11 dBm + 10 log B, where B is the 26 dB emission bandwidth in MHz.
<input type="checkbox"/>	For the 5.47-5.725 GHz band, the maximum conducted output power shall not exceed the lesser of 250 mW or 11 dBm + 10 log B, where B is the 26 dB emission bandwidth in MHz.
<input checked="" type="checkbox"/>	For the 5.725-5.85 GHz band, 6 dB emission bandwidth \geq 500kHz.
LE-LAN Devices	
<input type="checkbox"/>	For the band 5.15-5.25 GHz, the maximum e.i.r.p. shall not exceed 200 mW or 10 + 10 log B, dBm, whichever power is less. B is the 99% emission bandwidth in MHz.
<input type="checkbox"/>	For the 5.25-5.35 GHz band, the maximum e.i.r.p. shall not exceed 1.0 W or 17 + 10 log B, dBm, whichever power is less. B is the 99% emission bandwidth in MHz
<input type="checkbox"/>	For the 5.47-5.6 GHz band and 5.65-5.725 GHz band, the maximum e.i.r.p. shall not exceed 1.0 W or 17 + 10 log B, dBm, whichever power is less. B is the 99% emission bandwidth in MHz
<input type="checkbox"/>	For the 5.725-5.85 GHz band, 6 dB emission bandwidth \geq 500kHz.

3.2.2 Measuring Instruments

Refer a test equipment and calibration data table in this test report.

3.2.3 Test Procedures

Test Method							
<ul style="list-style-type: none"> ▪ For the emission bandwidth shall be measured using one of the options below: <table border="1" style="width: 100%; border-collapse: collapse;"> <tr> <td style="width: 30px;"><input checked="" type="checkbox"/></td> <td>Refer as FCC KDB 789033, clause C for EBW and clause D for OBW measurement.</td> </tr> <tr> <td><input type="checkbox"/></td> <td>Refer as ANSI C63.10, clause 6.9.1 for occupied bandwidth testing.</td> </tr> <tr> <td><input type="checkbox"/></td> <td>Refer as IC RSS-Gen, clause 4.6 for bandwidth testing.</td> </tr> </table> 		<input checked="" type="checkbox"/>	Refer as FCC KDB 789033, clause C for EBW and clause D for OBW measurement.	<input type="checkbox"/>	Refer as ANSI C63.10, clause 6.9.1 for occupied bandwidth testing.	<input type="checkbox"/>	Refer as IC RSS-Gen, clause 4.6 for bandwidth testing.
<input checked="" type="checkbox"/>	Refer as FCC KDB 789033, clause C for EBW and clause D for OBW measurement.						
<input type="checkbox"/>	Refer as ANSI C63.10, clause 6.9.1 for occupied bandwidth testing.						
<input type="checkbox"/>	Refer as IC RSS-Gen, clause 4.6 for bandwidth testing.						

3.2.4 Test Setup

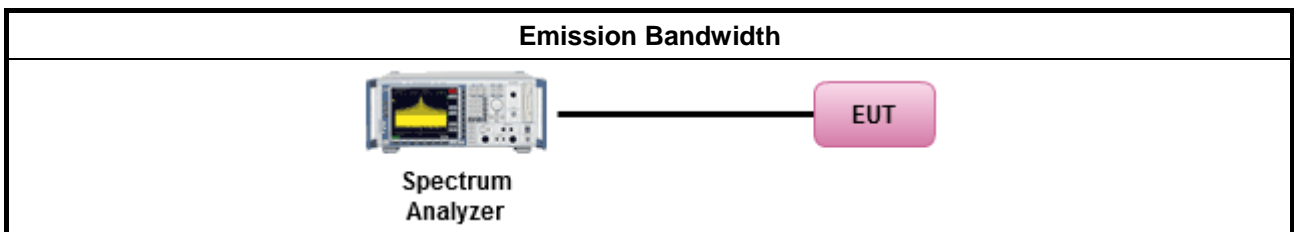

3.2.5 Test Result of Emission Bandwidth

Refer as Appendix B



3.3 Maximum Conducted Output Power

3.3.1 Maximum Conducted Output Power Limit

Maximum Conducted Output Power Limit	
UNII Devices	
<input checked="" type="checkbox"/> For the 5.15-5.25 GHz band:	
	<ul style="list-style-type: none"> ▪ Outdoor AP: the maximum conducted output power (P_{Out}) shall not exceed the lesser of 1 W. If $G_{TX} > 6$ dBi, then $P_{Out} = 30 - (G_{TX} - 6)$. e.i.r.p. at any elevation angle above 30 degrees ≤ 125mW [21dBm] ▪ Indoor AP: the maximum conducted output power (P_{Out}) shall not exceed the lesser of 1 W. If $G_{TX} > 6$ dBi, then $P_{Out} = 30 - (G_{TX} - 6)$ ▪ Point-to-point AP: the maximum conducted output power (P_{Out}) shall not exceed the lesser of 1 W. If $G_{TX} > 23$ dBi, then $P_{Out} = 30 - (G_{TX} - 23)$. ▪ Mobile or Portable Client: the maximum conducted output power (P_{Out}) shall not exceed the lesser of 250 mW. If $G_{TX} > 6$ dBi, then $P_{Out} = 24 - (G_{TX} - 6)$.
<input type="checkbox"/> For the 5.25-5.35 GHz band, the maximum conducted output power (P_{Out}) shall not exceed the lesser of 250 mW or 11 dBm + 10 log B, where B is the 26 dB emission bandwidth in MHz. If $G_{TX} > 6$ dBi, then $P_{Out} = 24 - (G_{TX} - 6)$.	
<input type="checkbox"/> For the 5.47-5.725 GHz band, the maximum conducted output power (P_{Out}) shall not exceed the lesser of 250 mW or 11 dBm + 10 log B, where B is the 26 dB emission bandwidth in MHz. If $G_{TX} > 6$ dBi, then $P_{Out} = 24 - (G_{TX} - 6)$.	
<input checked="" type="checkbox"/> For the 5.725-5.85 GHz band:	
	<ul style="list-style-type: none"> ▪ Point-to-multipoint systems (P2M): the maximum conducted output power (P_{Out}) shall not exceed the lesser of 1 W. If $G_{TX} > 6$ dBi, then $P_{Out} = 30 - (G_{TX} - 6)$. ▪ Point-to-point systems (P2P): the maximum conducted output power (P_{Out}) shall not exceed the lesser of 1 W.
LE-LAN Devices	
<input type="checkbox"/> For the 5.15-5.25 GHz band, the maximum e.i.r.p. shall not exceed 200 mW or 10 + 10 log B, dBm, whichever power is less. B is the 99% emission bandwidth in MHz.	
<input type="checkbox"/> For the 5.25-5.35 GHz band, the maximum e.i.r.p. shall not exceed 1.0 W or 17 + 10 log B, dBm, whichever power is less. B is the 99% emission bandwidth in MHz	
<input type="checkbox"/> For the 5.47-5.6 GHz band and 5.65-5.725 GHz band, the maximum e.i.r.p. shall not exceed 1.0 W or 17 + 10 log B, dBm, whichever power is less. B is the 99% emission bandwidth in MHz	
<input type="checkbox"/> For the 5.725-5.85 GHz band:	
	<ul style="list-style-type: none"> ▪ Point-to-multipoint systems (P2M): the maximum conducted output power (P_{Out}) shall not exceed the lesser of 1 W. If $G_{TX} > 6$ dBi, then $P_{Out} = 30 - (G_{TX} - 6)$. ▪ Point-to-point systems (P2P): the maximum conducted output power (P_{Out}) shall not exceed the lesser of 1 W.
P_{Out} = maximum conducted output power in dBm, G_{TX} = the maximum transmitting antenna directional gain in dBi.	

3.3.2 Measuring Instruments

Refer a test equipment and calibration data table in this test report.

3.3.3 Test Procedures

Test Method	
<ul style="list-style-type: none"> ▪ Maximum Conducted Output Power 	
Average over on/off periods with duty factor	
<input type="checkbox"/>	Refer as FCC KDB 789033, clause E Method SA-2 (spectral trace averaging).
<input type="checkbox"/>	Refer as FCC KDB 789033, clause E Method SA-2 Alt. (RMS detection with slow sweep speed)
Wideband RF power meter and average over on/off periods with duty factor	
<input checked="" type="checkbox"/>	Refer as FCC KDB 789033, clause E Method PM-G (using an RF average power meter).
<ul style="list-style-type: none"> ▪ For conducted measurement. 	
<ul style="list-style-type: none"> ▪ If the EUT supports multiple transmit chains using options given below: Refer as FCC KDB 662911, In-band power measurements. Using the measure-and-sum approach, measured all transmit ports individually. Sum the power (in linear power units e.g., mW) of all ports for each individual sample and save them. 	
<ul style="list-style-type: none"> ▪ If multiple transmit chains, EIRP calculation could be following as methods: $P_{total} = P_1 + P_2 + \dots + P_n$ (calculated in linear unit [mW] and transfer to log unit [dBm]) $EIRP_{total} = P_{total} + DG$ 	

3.3.4 Test Setup

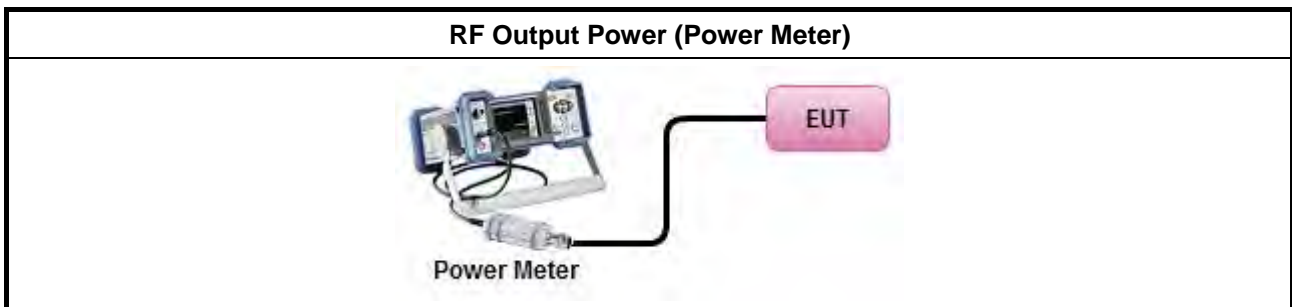

3.3.5 Test Result of Maximum Conducted Output Power

Refer as Appendix C



3.4 Peak Power Spectral Density

3.4.1 Peak Power Spectral Density Limit

Peak Power Spectral Density Limit	
UNII Devices	
<input checked="" type="checkbox"/> For the 5.15-5.25 GHz band:	
	<ul style="list-style-type: none"> ▪ Outdoor AP: the peak power spectral density (PPSD) shall not exceed the lesser of 17dBm/MHz. If $G_{TX} > 6$ dBi, then $P_{Out} = 17 - (G_{TX} - 6)$. ▪ Indoor AP: the peak power spectral density (PPSD) shall not exceed the lesser of 17dBm/MHz. If $G_{TX} > 6$ dBi, then $P_{Out} = 17 - (G_{TX} - 6)$. ▪ Point-to-point AP: the peak power spectral density (PPSD) shall not exceed the lesser of 17dBm/MHz. If $G_{TX} > 23$ dBi, then $P_{Out} = 17 - (G_{TX} - 23)$. ▪ Mobile or Portable Client: the peak power spectral density (PPSD) ≤ 11 dBm/MHz. If $G_{TX} > 6$ dBi, then $PPSD = 11 - (G_{TX} - 6)$.
<input type="checkbox"/> For the 5.25-5.35 GHz band, the peak power spectral density (PPSD) ≤ 11 dBm/MHz. If $G_{TX} > 6$ dBi, then $PPSD = 11 - (G_{TX} - 6)$.	
<input type="checkbox"/> For the 5.47-5.725 GHz band, the peak power spectral density (PPSD) ≤ 11 dBm/MHz. If $G_{TX} > 6$ dBi, then $PPSD = 11 - (G_{TX} - 6)$.	
<input checked="" type="checkbox"/> For the 5.725-5.85 GHz band:	
	<ul style="list-style-type: none"> ▪ Point-to-multipoint systems (P2M): the peak power spectral density (PPSD) ≤ 30 dBm/500kHz. If $G_{TX} > 6$ dBi, then $PPSD = 30 - (G_{TX} - 6)$. ▪ Point-to-point systems (P2P): the peak power spectral density (PPSD) ≤ 30 dBm/500kHz.
LE-LAN Devices	
<input type="checkbox"/> For the 5.15-5.25 GHz band, the e.i.r.p. peak power spectral density (PPSD) ≤ 10 dBm/MHz.	
<input type="checkbox"/> For the 5.25-5.35 GHz band, the peak power spectral density (PPSD) ≤ 11 dBm/MHz.	
	<ul style="list-style-type: none"> ▪ e.i.r.p. greater than 200 mW shall comply with the following e.i.r.p. at different elevations, where θ is the angle above the local horizontal plane (of the Earth) as shown below: -13 dBW/MHz for $0^\circ \leq \theta < 8^\circ$; -13 - 0.716 ($\theta-8$) dBW/MHz for $8^\circ \leq \theta < 40^\circ$ -35.9 - 1.22 ($\theta-40$) dBW/MHz for $40^\circ \leq \theta \leq 45^\circ$; -42 dBW/MHz for $\theta > 45^\circ$
<input type="checkbox"/> For the 5.47-5.6 GHz band and 5.65-5.725 GHz band, the peak power spectral density (PPSD) ≤ 11 dBm/MHz.	
<input type="checkbox"/> For the 5.725-5.85 GHz band:	
	<ul style="list-style-type: none"> ▪ Point-to-multipoint systems (P2M): the peak power spectral density (PPSD) ≤ 30 dBm/500kHz. If $G_{TX} > 6$ dBi, then $PPSD = 30 - (G_{TX} - 6)$. ▪ Point-to-point systems (P2P): the peak power spectral density (PPSD) ≤ 30 dBm/500kHz.
<p>PPSD = peak power spectral density that he same method as used to determine the conducted output power shall be used to determine the power spectral density. And power spectral density in dBm/MHz G_{TX} = the maximum transmitting antenna directional gain in dBi.</p>	

3.4.2 Measuring Instruments

Refer a test equipment and calibration data table in this test report.



3.4.3 Test Procedures

Test Method	
<ul style="list-style-type: none"> ▪ Peak power spectral density procedures that the same method as used to determine the conducted output power shall be used to determine the peak power spectral density and use the peak search function on the spectrum analyzer to find the peak of the spectrum. For the peak power spectral density shall be measured using below options: 	
<input type="checkbox"/>	Refer as FCC KDB 789033, F5) power spectral density can be measured using resolution bandwidths < 1 MHz provided that the results are integrated over 1 MHz bandwidth
[duty cycle ≥ 98% or external video / power trigger]	
<input checked="" type="checkbox"/>	Refer as FCC KDB 789033, clause E Method SA-1 (spectral trace averaging).
<input type="checkbox"/>	Refer as FCC KDB 789033, clause E Method SA-1 Alt. (RMS detection with slow sweep speed)
duty cycle < 98% and average over on/off periods with duty factor	
<input checked="" type="checkbox"/>	Refer as FCC KDB 789033, clause E Method SA-2 (spectral trace averaging).
<input type="checkbox"/>	Refer as FCC KDB 789033, clause E Method SA-2 Alt. (RMS detection with slow sweep speed)
<ul style="list-style-type: none"> ▪ For conducted measurement. 	
<ul style="list-style-type: none"> ▪ If the EUT supports multiple transmit chains using options given below: 	
<input checked="" type="checkbox"/>	Option 1: Measure and sum the spectra across the outputs. Refer as FCC KDB 662911, In-band power spectral density (PSD). Sample all transmit ports simultaneously using a spectrum analyzer for each transmit port. Where the trace bin-by-bin of each transmit port summing can be performed. (i.e., in the first spectral bin of output 1 is summed with that in the first spectral bin of output 2 and that from the first spectral bin of output 3, and so on up to the NTX output to obtain the value for the first frequency bin of the summed spectrum.). Add up the amplitude (power) values for the different transmit chains and use this as the new data trace.
<input type="checkbox"/>	Option 2: Measure and sum spectral maxima across the outputs. With this technique, spectra are measured at each output of the device at the required resolution bandwidth. The maximum value (peak) of each spectrum is determined. These maximum values are then summed mathematically in linear power units across the outputs. These operations shall be performed separately over frequency spans that have different out-of-band or spurious emission limits,
<input type="checkbox"/>	Option 3: Measure and add 10 log(N) dB, where N is the number of transmit chains. Refer as FCC KDB 662911, In-band power spectral density (PSD). Performed at each transmit chains and each transmit chains shall be compared with the limit have been reduced with 10 log(N). Or each transmit chains shall be add 10 log(N) to compared with the limit.
<ul style="list-style-type: none"> ▪ If multiple transmit chains, EIRP PPSD calculation could be following as methods: $PPSD_{total} = PPSD_1 + PPSD_2 + \dots + PPSD_n$ (calculated in linear unit [mW] and transfer to log unit [dBm]) $EIRP_{total} = PPSD_{total} + DG$ 	

3.4.4 Test Setup

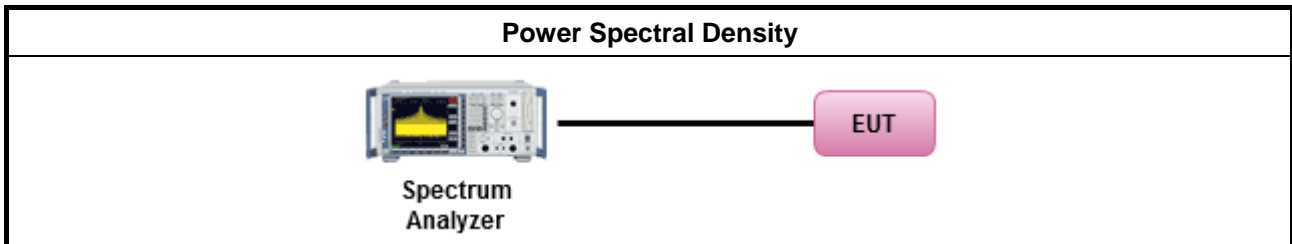

3.4.5 Test Result of Peak Power Spectral Density

Refer as Appendix D



3.5 Unwanted Emissions

3.5.1 Transmitter Unwanted Emissions Limit

Unwanted emissions below 1 GHz and restricted band emissions above 1GHz limit			
Frequency Range (MHz)	Field Strength (uV/m)	Field Strength (dBuV/m)	Measure Distance (m)
0.009~0.490	2400/F(kHz)	48.5 - 13.8	300
0.490~1.705	24000/F(kHz)	33.8 - 23	30
1.705~30.0	30	29	30
30~88	100	40	3
88~216	150	43.5	3
216~960	200	46	3
Above 960	500	54	3

Note 1: Test distance for frequencies at or above 30 MHz, measurements may be performed at a distance other than the limit distance provided they are not performed in the near field and the emissions to be measured can be detected by the measurement equipment. When performing measurements at a distance other than that specified, the results shall be extrapolated to the specified distance using an extrapolation factor of 20 dB/decade (inverse of linear distance for field-strength measurements, inverse of linear distance-squared for power-density measurements).

Note 2: Test distance for frequencies at below 30 MHz, measurements may be performed at a distance closer than the EUT limit distance; however, an attempt should be made to avoid making measurements in the near field. When performing measurements below 30 MHz at a closer distance than the limit distance, the results shall be extrapolated to the specified distance by either making measurements at a minimum of two or more distances on at least one radial to determine the proper extrapolation factor or by using the square of an inverse linear distance extrapolation factor (40 dB/decade). The test report shall specify the extrapolation method used to determine compliance of the EUT.

Note 3: Using the distance of 1m during the test for above 18 GHz, and the test value to correct for the distance factor at 3m.

Un-restricted band emissions above 1GHz Limit	
Operating Band	Limit
<input checked="" type="checkbox"/> 5.15 - 5.25 GHz	e.i.r.p. -27 dBm [68.2 dBuV/m@3m]
<input type="checkbox"/> 5.25 - 5.35 GHz	e.i.r.p. -27 dBm [68.2 dBuV/m@3m]
<input type="checkbox"/> 5.47 - 5.725 GHz	e.i.r.p. -27 dBm [68.2 dBuV/m@3m]
<input checked="" type="checkbox"/> 5.725 - 5.85 GHz	all emissions shall be limited to a level of -27 dBm/MHz at 75 MHz or more above or below the band edge increasing linearly to 10 dBm/MHz at 25 MHz above or below the band edge, and from 25 MHz above or below the band edge increasing linearly to a level of 15.6 dBm/MHz at 5 MHz above or below the band edge, and from 5 MHz above or below the band edge increasing linearly to a level of 27 dBm/MHz at the band edge.

Note 1: Measurements may be performed at a distance other than the limit distance provided they are not performed in the near field and the emissions to be measured can be detected by the measurement equipment. When performing measurements at a distance other than that specified, the results shall be extrapolated to the specified distance using an extrapolation factor of 20 dB/decade (inverse of



linear distance for field-strength measurements, inverse of linear distance-squared for power-density measurements).

3.5.2 Measuring Instruments

Refer a test equipment and calibration data table in this test report.

3.5.3 Test Procedures

Test Method	
	<ul style="list-style-type: none"> ▪ Measurements may be performed at a distance other than the limit distance provided they are not performed in the near field and the emissions to be measured can be detected by the measurement equipment. Measurements shall not be performed at a distance greater than 30 m for frequencies above 30 MHz, unless it can be further demonstrated that measurements at a distance of 30 m or less are impractical. When performing measurements at a distance other than that specified, the results shall be extrapolated to the specified distance using an extrapolation factor of 20 dB/decade (inverse of linear distance for field-strength measurements, inverse of linear distance-squared for power-density measurements).
	<ul style="list-style-type: none"> ▪ The average emission levels shall be measured in [duty cycle ≥ 98 or duty factor].
	<ul style="list-style-type: none"> ▪ For the transmitter unwanted emissions shall be measured using following options below: <ul style="list-style-type: none"> ▪ Refer as FCC KDB 789033, clause G)2) for unwanted emissions into non-restricted bands. ▪ Refer as FCC KDB 789033, clause G)1) for unwanted emissions into restricted bands. <ul style="list-style-type: none"> <input type="checkbox"/> Refer as FCC KDB 789033, G)6) Method AD (Trace Averaging). <input checked="" type="checkbox"/> Refer as FCC KDB 789033, G)6) Method VB (Reduced VBW). <input type="checkbox"/> Refer as ANSI C63.10, clause 11.12.2.5.3 (Reduced VBW). VBW ≥ 1/T, where T is pulse time. <input type="checkbox"/> Refer as ANSI C63.10, clause 7.5 average value of pulsed emissions. <input checked="" type="checkbox"/> Refer as FCC KDB 789033, clause G)5) measurement procedure peak limit. <input type="checkbox"/> Refer as ANSI C63.10, clause 4.1.4.2.2 measurement procedure peak limit.
	<ul style="list-style-type: none"> ▪ For radiated measurement. <ul style="list-style-type: none"> ▪ Refer as ANSI C63.10, clause 6.4 for radiated emissions below 30 MHz and test distance is 3m. ▪ Refer as ANSI C63.10, clause 6.5 for radiated emissions 30 MHz to 1 GHz and test distance is 3m. ▪ Refer as ANSI C63.10, clause 6.6 for radiated emissions above 1GHz.
	<ul style="list-style-type: none"> ▪ The any unwanted emissions level shall not exceed the fundamental emission level.
	<ul style="list-style-type: none"> ▪ All amplitude of spurious emissions that are attenuated by more than 20 dB below the permissible value has no need to be reported.

3.5.4 Test Setup

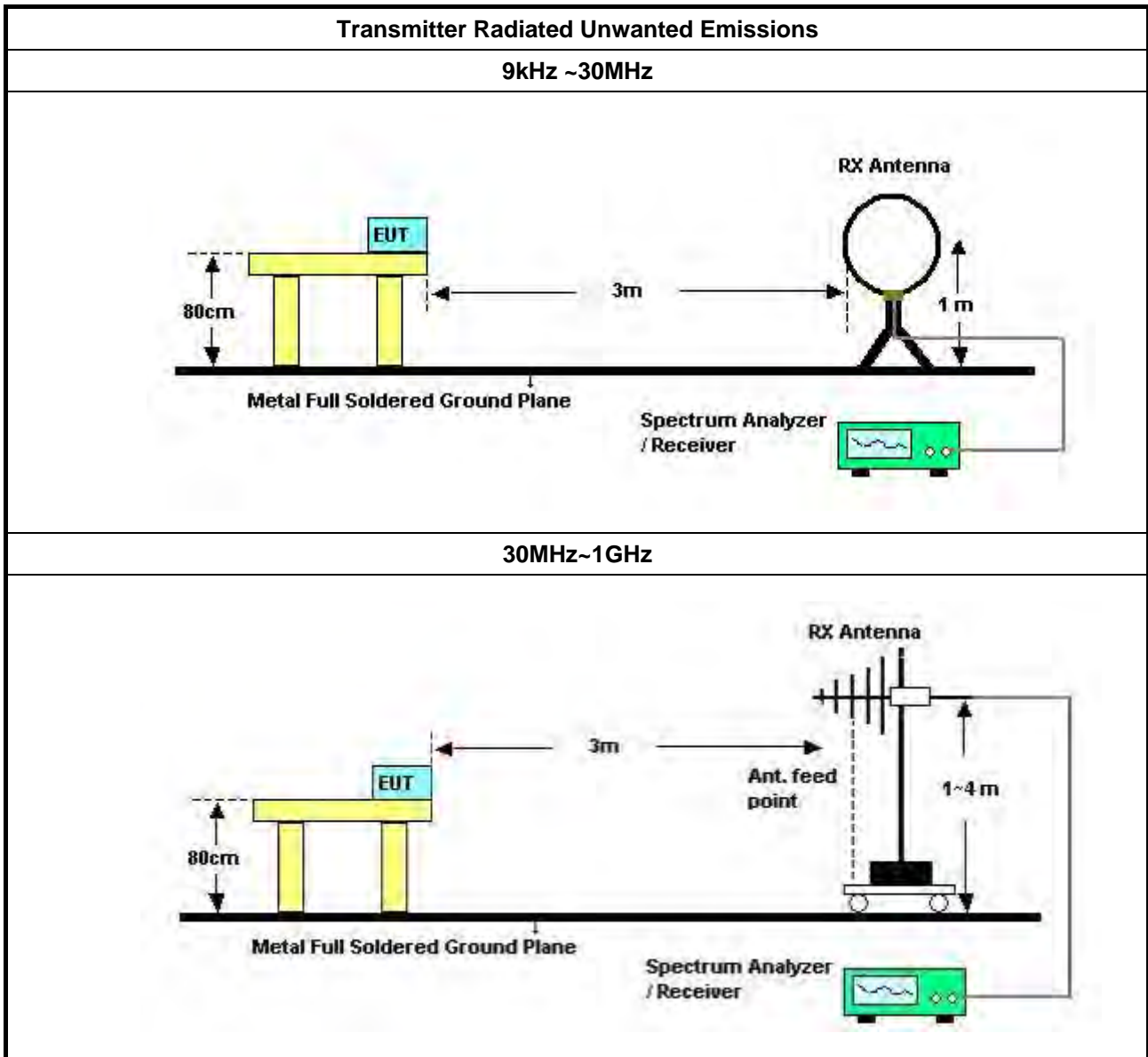

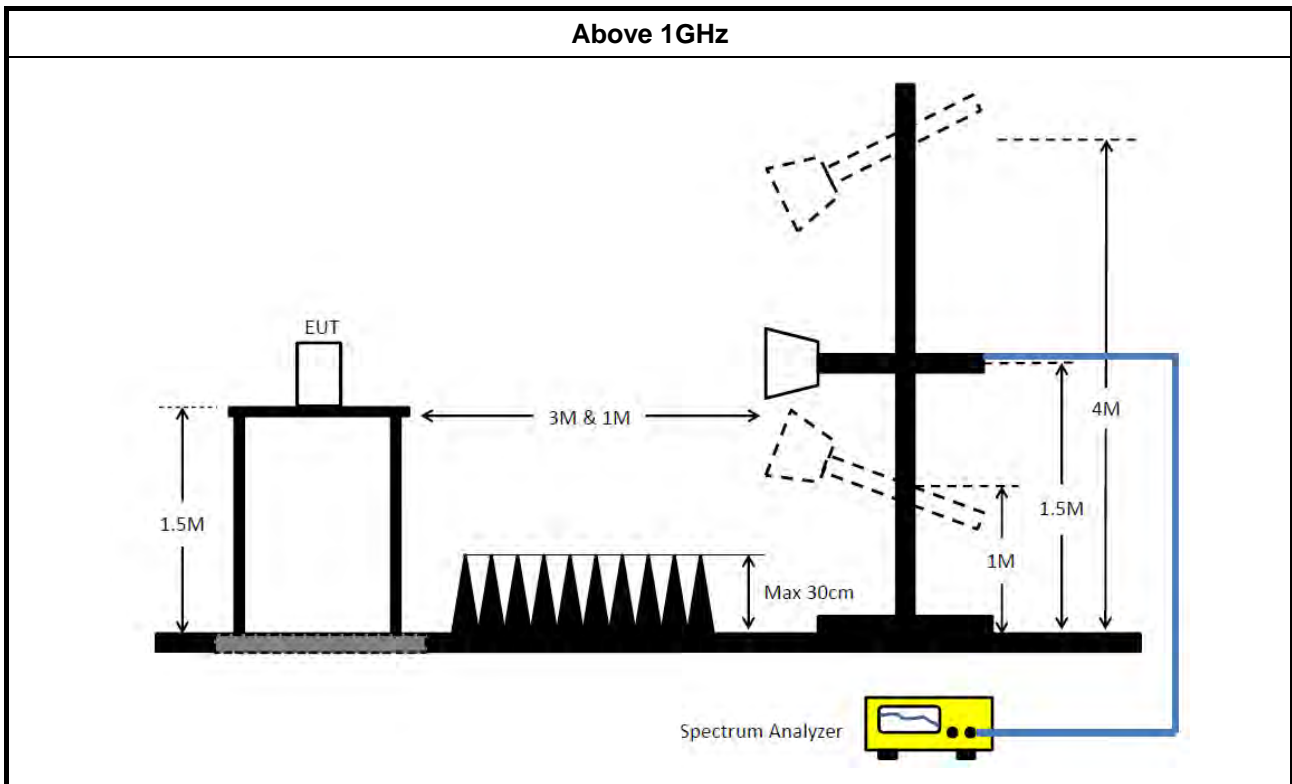

3.5.5 Measurement Results Calculation

The measured Level is calculated using:
 Corrected Reading: Antenna Factor + Cable Loss + Read Level - Preamp Factor = Level.

3.5.6 Transmitter Unwanted Emissions (Below 30MHz)

There is a comparison data of both open-field test site and alternative test site - semi-Anechoic chamber according to KDB414788 Radiated Test Site, and the result came out very similar.
 All amplitude of spurious emissions that are attenuated by more than 20 dB below the permissible value has no need to be reported.
 The radiated emissions were investigated from 9 kHz or the lowest frequency generated within the device, up to the 10 harmonic or 40 GHz, whichever is appropriate.

3.5.7 Test Result of Transmitter Unwanted Emissions

Refer as Appendix E



4 Test Equipment and Calibration Data

Instrument	Manufacturer	Model No.	Serial No.	Characteristics	Calibration Date	Calibration Due Date	Remark
EMI Receiver	Agilent	N9038A	My52260123	9kHz ~ 8.45GHz	Jan. 28, 2019	Jan. 29, 2020	Conduction (CO01-CB)
LISN	F.C.C.	FCC-LISN-50-16-2	04083	150kHz ~ 100MHz	Dec. 24, 2018	Dec. 23, 2019	Conduction (CO01-CB)
LISN	Schwarzbeck	NSLK 8127	8127647	9kHz ~ 30MHz	Jan. 11, 2019	Jan. 10, 2020	Conduction (CO01-CB)
COND Cable	Woken	Cable	Low cable-CO01	9kHz ~ 30MHz	May 21, 2019	May 20, 2020	Conduction (CO01-CB)
Software	Audix	E3	6.120210n	-	N.C.R.	N.C.R.	Conduction (CO01-CB)
Loop Antenna	Teseq	HLA 6120	24155	9kHz - 30 MHz	Mar. 29, 2019	Mar. 28, 2020	Radiation (03CH05-CB)
Bilog Antenna with 6dB Attenuator	TESE & EMCI	CBL 6112D & N-6-06	35236 & AT-N0610	30MHz ~ 2GHz	Mar. 28, 2019	Mar. 27, 2020	Radiation (03CH05-CB)
Pre-Amplifier	EMCI	EMC330N	980331	20MHz ~ 3GHz	May 02, 2019	May 01, 2020	Radiation (03CH05-CB)
Spectrum Analyzer	R&S	FSP40	100304	9kHz ~ 40GHz	Aug. 15, 2019	Aug. 14, 2020	Radiation (03CH05-CB)
EMI Test Receiver	R&S	ESCS	826547/017	9kHz ~ 2.75GHz	May 15, 2019	May 14, 2020	Radiation (03CH05-CB)
RF Cable-low	Woken	RG402	LOW Cable-04+23	30MHz~1GHz	Oct. 07, 2019	Oct. 06, 2020	Radiation (03CH05-CB)
Horn Antenna	SCHWARZBECK	BBHA9120D	9120D-1292	1GHz~18GHz	Jul. 17, 2019	Jul. 16, 2020	Radiation (03CH06-CB)
Horn Antenna	SCHWARZBECK	BBHA 9170	BBHA9170507	15GHz ~ 40GHz	Jun. 12, 2019	Jun. 11, 2020	Radiation (03CH06-CB)
Pre-Amplifier	Agilent	83017A	MY53270064	0.5GHz ~ 26.5GHz	May 08, 2019	May 07, 2020	Radiation (03CH06-CB)
Pre-Amplifier	MITEQ	TTA1840-35-HG	1864479	18GHz ~ 40GHz	Jul. 03, 2019	Jul. 02, 2020	Radiation (03CH06-CB)
Spectrum analyzer	R&S	FSP40	100080	9kHz~40GHz	Oct. 21, 2019	Oct. 20, 2020	Radiation (03CH06-CB)
RF Cable-high	HUBER+SUHNER	RG402	High Cable-05	1GHz~18GHz	Oct. 07, 2019	Oct. 06, 2020	Radiation (03CH06-CB)
RF Cable-high	HUBER+SUHNER	RG402	High Cable-05+24	1GHz~18GHz	Oct. 07, 2019	Oct. 06, 2020	Radiation (03CH06-CB)
RF Cable-high	Woken	RG402	High Cable-40G#1	18GHz ~ 40 GHz	Jul. 24, 2019	Jul. 23, 2020	Radiation (03CH06-CB)
RF Cable-high	Woken	RG402	High Cable-40G#2	18GHz ~ 40 GHz	Jul. 24, 2019	Jul. 23, 2020	Radiation (03CH06-CB)
Spectrum analyzer	R&S	FSV40	101027	9kHz~40GHz	Jul. 02, 2019	Jul. 01, 2020	Conducted (TH02-CB)
Power Sensor	Anritsu	MA2411B	1126203	300MHz~40GHz	Sep. 11, 2019	Sep. 10, 2020	Conducted (TH02-CB)



Instrument	Manufacturer	Model No.	Serial No.	Characteristics	Calibration Date	Calibration Due Date	Remark
Power Meter	Anritsu	ML2495A	1210004	300MHz~40GHz	Sep. 11, 2019	Sep. 10, 2020	Conducted (TH02-CB)
RF Cable-high	Woken	RG402	High Cable-01	1 GHz – 26.5 GHz	Oct. 07, 2019	Oct. 06, 2020	Conducted (TH02-CB)
RF Cable-high	Woken	RG402	High Cable-02	1 GHz – 26.5 GHz	Oct. 07, 2019	Oct. 06, 2020	Conducted (TH02-CB)
RF Cable-high	Woken	RG402	High Cable-3	1 GHz – 26.5 GHz	Oct. 07, 2019	Oct. 06, 2020	Conducted (TH02-CB)
RF Cable-high	Woken	RG402	High Cable-04	1 GHz – 26.5 GHz	Oct. 07, 2019	Oct. 06, 2020	Conducted (TH02-CB)
RF Cable-high	Woken	RG402	High Cable-05	1 GHz – 26.5 GHz	Oct. 07, 2019	Oct. 06, 2020	Conducted (TH02-CB)

Note: Calibration Interval of instruments listed above is one year.

N.C.R. means Non-Calibration required.



AC Power-line Conducted Emissions Result

Appendix A

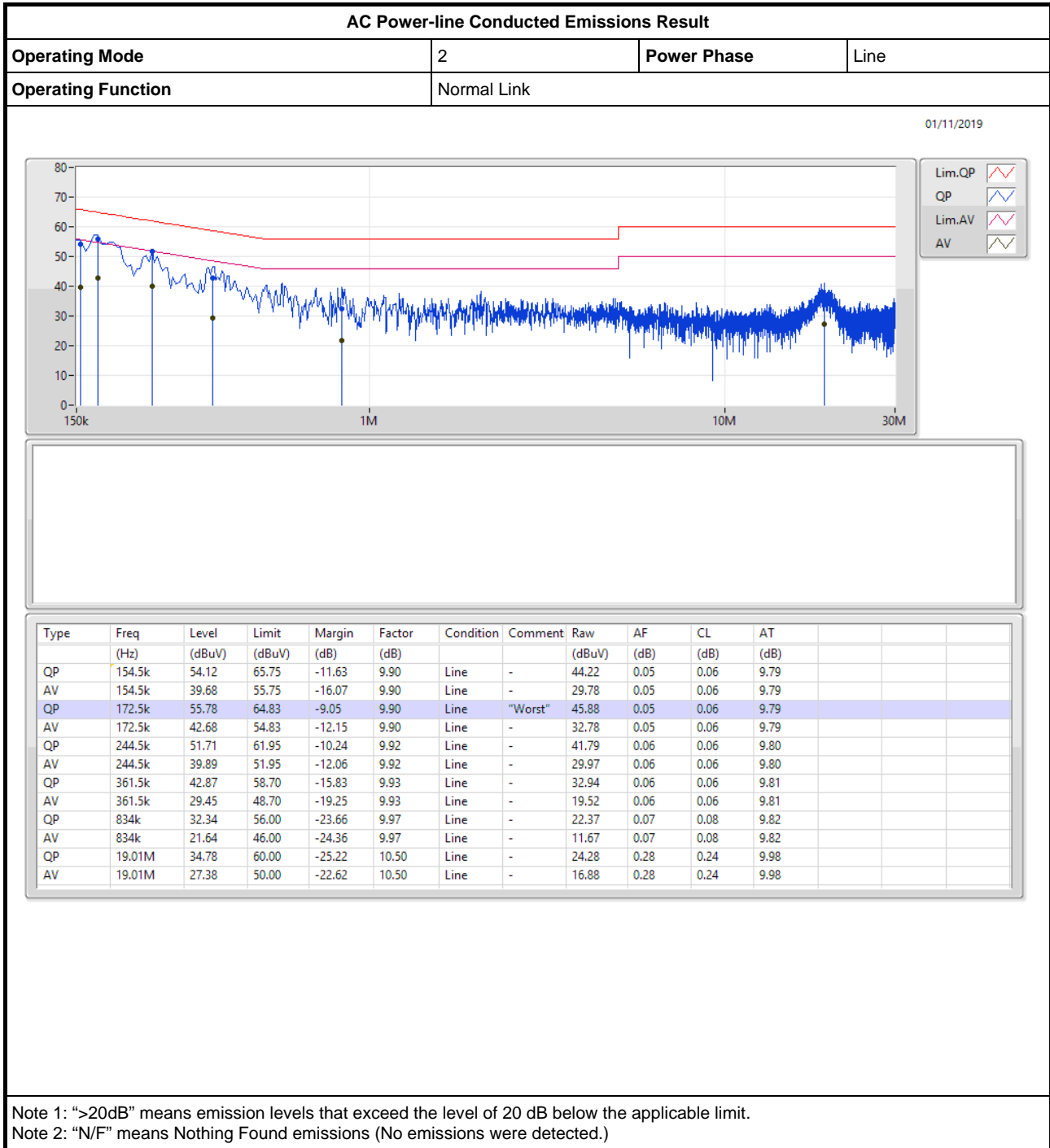



AC Power-line Conducted Emissions Result

Appendix A

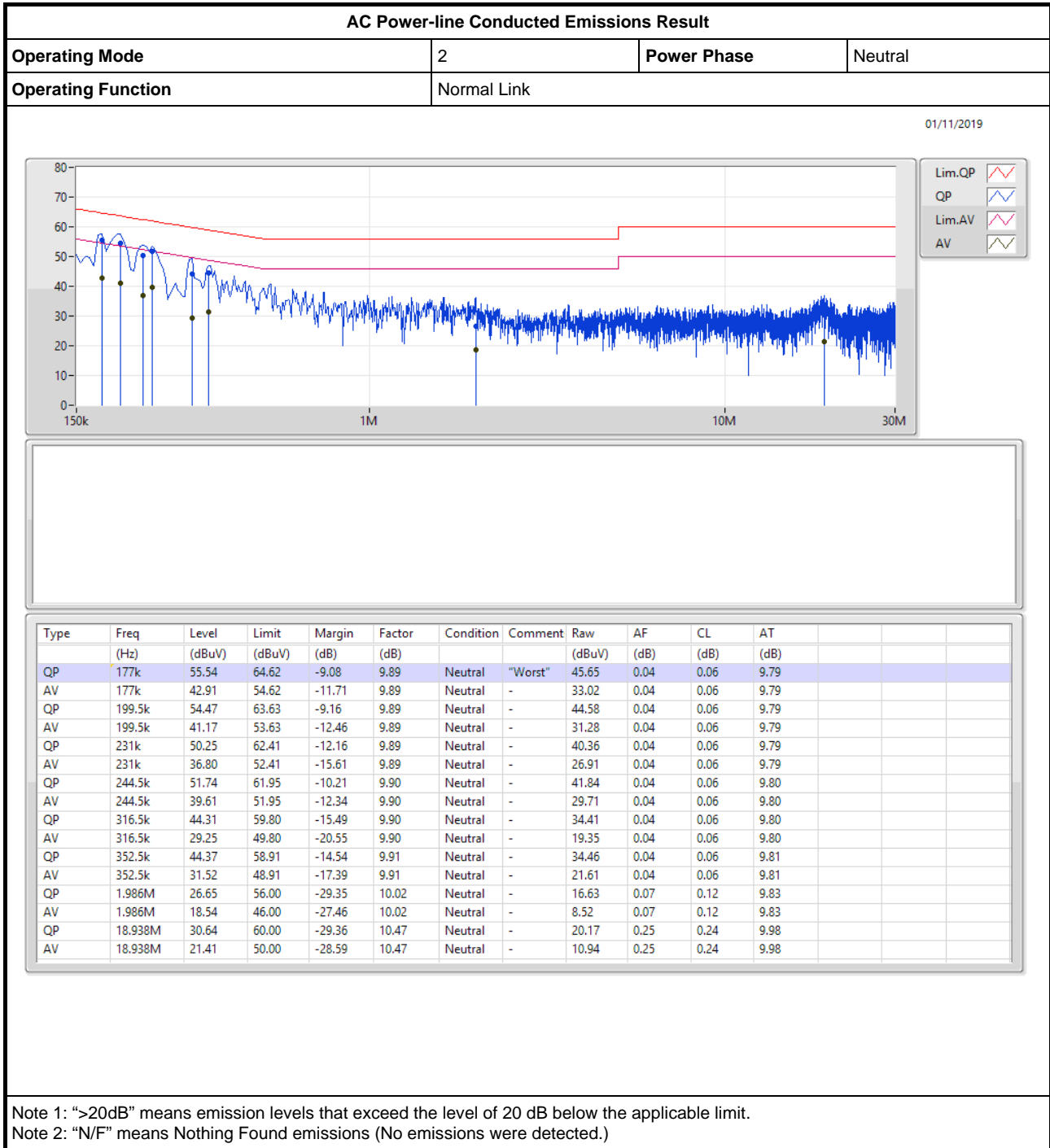



Summary

Mode	Max-N dB (Hz)	Max-OBW (Hz)	ITU-Code	Min-N dB (Hz)	Min-OBW (Hz)
5.15-5.25GHz	-	-	-	-	-
802.11a_Nss1,(6Mbps)_3TX	37.25M	19.54M	19M5D1D	22.475M	16.467M
802.11ac VHT20_Nss1,(MCS0)_3TX	43.1M	19.265M	19M3D1D	23.3M	17.666M
802.11ac VHT40_Nss1,(MCS0)_3TX	78.25M	36.832M	36M8D1D	43.7M	36.132M
802.11ac VHT80_Nss1,(MCS0)_3TX	89.3M	75.162M	75M2D1D	85.6M	74.963M
5.725-5.85GHz	-	-	-	-	-
802.11a_Nss1,(6Mbps)_3TX	16.45M	16.567M	16M6D1D	16.375M	16.492M
802.11ac VHT20_Nss1,(MCS0)_3TX	17.75M	17.791M	17M8D1D	17.575M	17.716M
802.11ac VHT40_Nss1,(MCS0)_3TX	36.4M	36.332M	36M3D1D	36.35M	36.182M
802.11ac VHT80_Nss1,(MCS0)_3TX	75.7M	75.562M	75M6D1D	75.4M	75.362M

Max-N dB = Maximum 6dB down bandwidth for 5.725-5.85GHz band / Maximum 26dB down bandwidth for other band;

Max-OBW = Maximum 99% occupied bandwidth;

Min-N dB = Minimum 6dB down bandwidth for 5.725-5.85GHz band / Maximum 26dB down bandwidth for other band;

Min-OBW = Minimum 99% occupied bandwidth;

Result

Mode	Result	Limit (Hz)	Port 1-N dB (Hz)	Port 1-OBW (Hz)	Port 2-N dB (Hz)	Port 2-OBW (Hz)	Port 3-N dB (Hz)	Port 3-OBW (Hz)
802.11a_Nss1,(6Mbps)_3TX	-	-	-	-	-	-	-	-
5180MHz	Pass	Inf	22.525M	16.517M	22.475M	16.467M	24.25M	16.517M
5200MHz	Pass	Inf	37.25M	17.191M	36.6M	16.942M	37.025M	19.54M
5240MHz	Pass	Inf	37.225M	16.917M	36.8M	17.091M	36.425M	18.091M
5745MHz	Pass	500k	16.45M	16.567M	16.4M	16.492M	16.375M	16.567M
5785MHz	Pass	500k	16.45M	16.542M	16.45M	16.567M	16.4M	16.567M
5825MHz	Pass	500k	16.4M	16.517M	16.425M	16.542M	16.375M	16.542M
802.11ac VHT20_Nss1,(MCS0)_3TX	-	-	-	-	-	-	-	-
5180MHz	Pass	Inf	23.725M	17.691M	23.4M	17.691M	23.3M	17.666M
5200MHz	Pass	Inf	42.575M	17.991M	36.95M	17.941M	43.1M	19.265M
5240MHz	Pass	Inf	42.2M	17.941M	40.5M	17.941M	42.4M	18.341M
5745MHz	Pass	500k	17.725M	17.741M	17.625M	17.716M	17.575M	17.766M
5785MHz	Pass	500k	17.675M	17.716M	17.625M	17.791M	17.625M	17.741M
5825MHz	Pass	500k	17.75M	17.766M	17.625M	17.716M	17.6M	17.716M
802.11ac VHT40_Nss1,(MCS0)_3TX	-	-	-	-	-	-	-	-
5190MHz	Pass	Inf	46.5M	36.132M	46M	36.132M	43.7M	36.282M
5230MHz	Pass	Inf	77M	36.532M	76.5M	36.482M	78.25M	36.832M
5755MHz	Pass	500k	36.4M	36.232M	36.35M	36.232M	36.35M	36.282M
5795MHz	Pass	500k	36.4M	36.182M	36.4M	36.232M	36.4M	36.332M
802.11ac VHT80_Nss1,(MCS0)_3TX	-	-	-	-	-	-	-	-
5210MHz	Pass	Inf	89.3M	75.162M	86.6M	74.963M	85.6M	75.062M
5775MHz	Pass	500k	75.6M	75.562M	75.7M	75.462M	75.4M	75.362M

Port X-N dB = Port X 6dB down bandwidth for 5.725-5.85GHz band / 26dB down bandwidth for other band

Port X-OBW = Port X 99% occupied bandwidth;

802.11a_Nss1,(6Mbps)_3TX

EBW

5180MHz

31/10/2019

CF: 5.18GHz
 Span: 50MHz
 RBW: 300kHz
 VBW: 1MHz
 Sweep Time: 100ms
 Detector Type: Peak

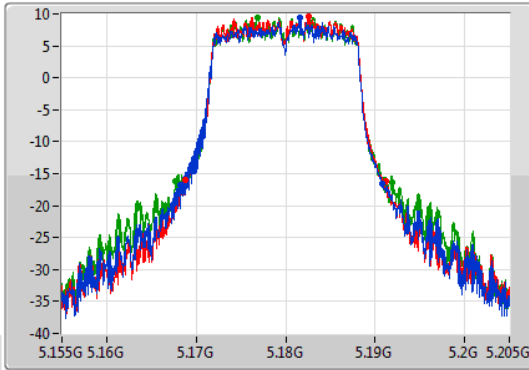

CF: 5.18GHz
 Span: 50MHz
 RBW: 200kHz
 VBW: 1MHz
 Sweep Time: 100ms
 Detector Type: Sample

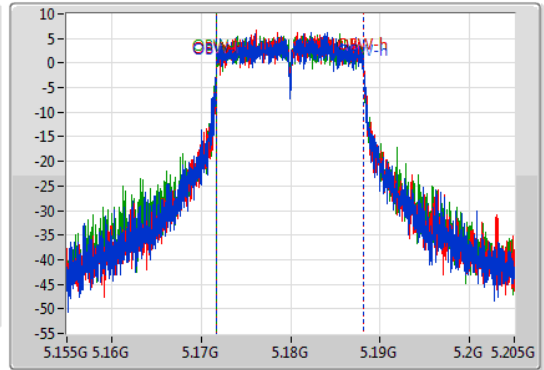

26dB(Hz)	Fl-26dB(Hz)	Fh-26dB(Hz)	OBW(Hz)	Fl-OBW(Hz)	Fh-OBW(Hz)	Limit(Hz)	Port
22.525M	5.1683G	5.190825G	16.517M	5.171679G	5.188196G	Inf	1
22.475M	5.168725G	5.1912G	16.467M	5.171729G	5.188196G	Inf	2
24.25M	5.167725G	5.191975G	16.517M	5.171679G	5.188196G	Inf	3

802.11a_Nss1,(6Mbps)_3TX

EBW

5200MHz

31/10/2019

CF: 5.2GHz
 Span: 50MHz
 RBW: 500kHz
 VBW: 2MHz
 Sweep Time: 100ms
 Detector Type: Peak

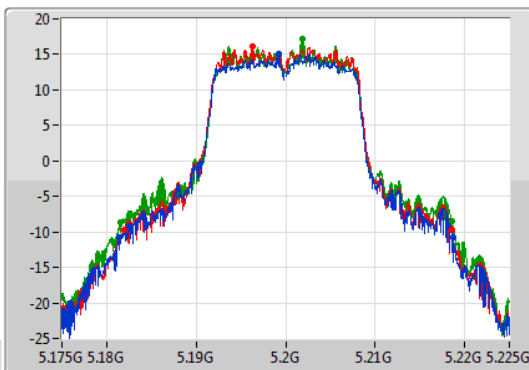

CF: 5.2GHz
 Span: 50MHz
 RBW: 200kHz
 VBW: 1MHz
 Sweep Time: 100ms
 Detector Type: Sample

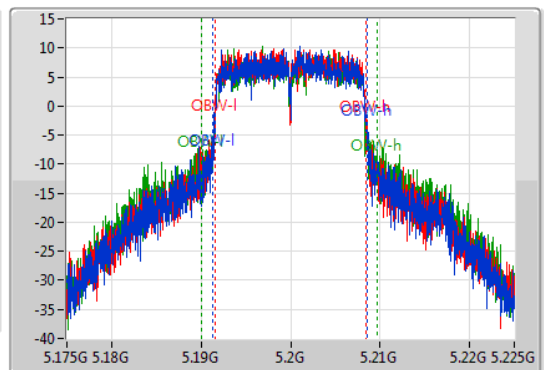

26dB(Hz)	Fl-26dB(Hz)	Fh-26dB(Hz)	OBW(Hz)	Fl-OBW(Hz)	Fh-OBW(Hz)	Limit(Hz)	Port
37.25M	5.181425G	5.218675G	17.191M	5.191354G	5.208546G	Inf	1
36.6M	5.18195G	5.21855G	16.942M	5.191504G	5.208446G	Inf	2
37.025M	5.181575G	5.2186G	19.54M	5.19008G	5.20962G	Inf	3

802.11a_Nss1,(6Mbps)_3TX

EBW

5240MHz

31/10/2019

CF
5.24GHz
Span
50MHz
RBW
500kHz
VBW
2MHz
Sweep Time
100ms
Detector Type
Peak

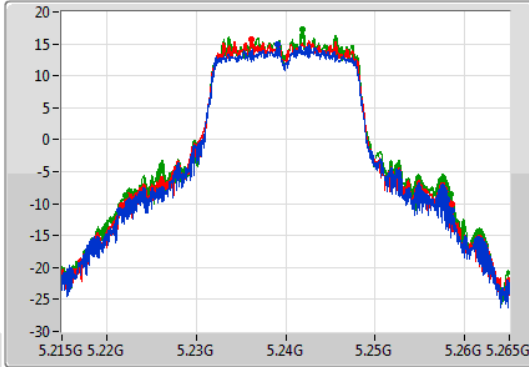

CF
5.24GHz
Span
50MHz
RBW
200kHz
VBW
1MHz
Sweep Time
100ms
Detector Type
Sample

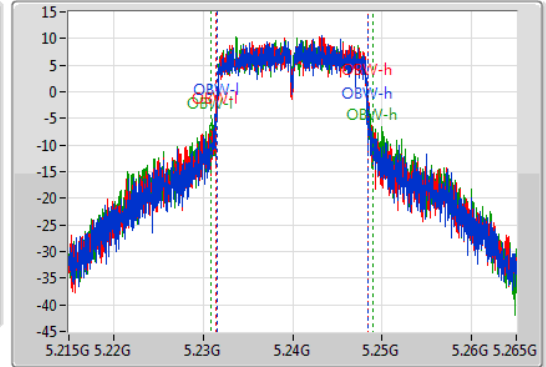

26dB(Hz)	Fl-26dB(Hz)	Fh-26dB(Hz)	OBW(Hz)	Fl-OBW(Hz)	Fh-OBW(Hz)	Limit(Hz)	Port
37.225M	5.221425G	5.25865G	16.917M	5.231529G	5.248446G	Inf	1
36.8M	5.221725G	5.258525G	17.091M	5.231379G	5.248471G	Inf	2
36.425M	5.222075G	5.2585G	18.091M	5.230905G	5.248996G	Inf	3

802.11a_Nss1,(6Mbps)_3TX

EBW

5745MHz

01/11/2019

CF
5.745GHz
Span
50MHz
RBW
100kHz
VBW
300kHz
Sweep Time
100ms
Detector Type
Peak

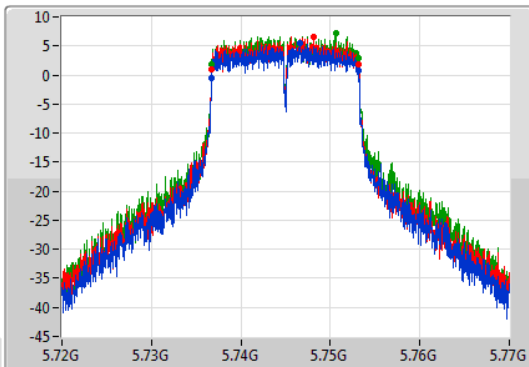

CF
5.745GHz
Span
50MHz
RBW
200kHz
VBW
1MHz
Sweep Time
100ms
Detector Type
Sample

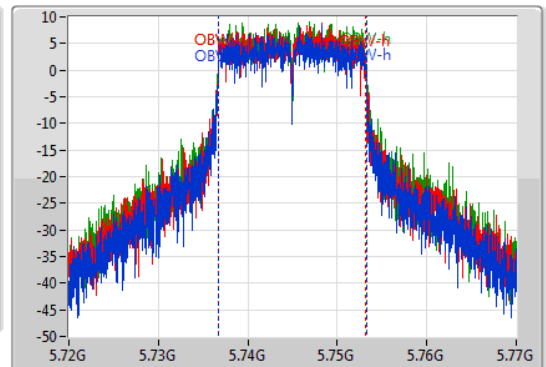

6dB(Hz)	Fl-6dB(Hz)	Fh-6dB(Hz)	OBW(Hz)	Fl-OBW(Hz)	Fh-OBW(Hz)	Limit(Hz)	Port
16.45M	5.7367G	5.75315G	16.567M	5.736654G	5.753221G	500k	1
16.4M	5.73675G	5.75315G	16.492M	5.736704G	5.753196G	500k	2
16.375M	5.736775G	5.75315G	16.567M	5.736679G	5.753246G	500k	3

802.11a_Nss1,(6Mbps)_3TX

EBW

5785MHz

01/11/2019

CF
5.785GHz
Span
50MHz
RBW
100kHz
VBW
300kHz
Sweep Time
100ms
Detector Type
Peak

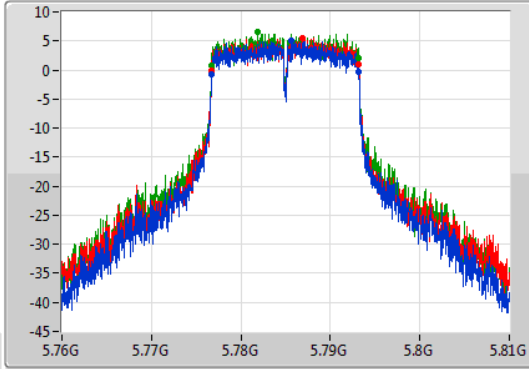

CF
5.785GHz
Span
50MHz
RBW
200kHz
VBW
1MHz
Sweep Time
100ms
Detector Type
Sample

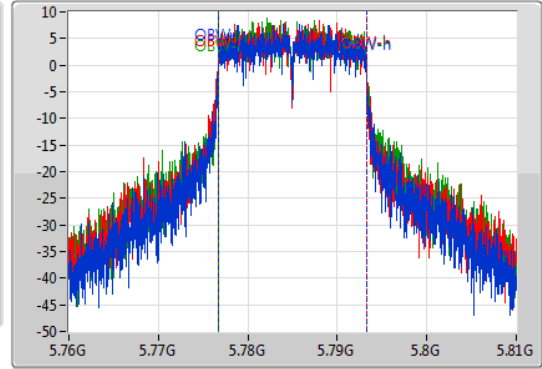

6dB(Hz)	Fl-6dB(Hz)	Fh-6dB(Hz)	OBW(Hz)	Fl-OBW(Hz)	Fh-OBW(Hz)	Limit(Hz)	Port
16.45M	5.7767G	5.79315G	16.542M	5.776679G	5.793221G	500k	1
16.45M	5.7767G	5.79315G	16.567M	5.776654G	5.793221G	500k	2
16.4M	5.77675G	5.79315G	16.567M	5.776679G	5.793246G	500k	3

802.11a_Nss1,(6Mbps)_3TX

EBW

5825MHz

01/11/2019

CF
5.825GHz
Span
50MHz
RBW
100kHz
VBW
300kHz
Sweep Time
100ms
Detector Type
Peak

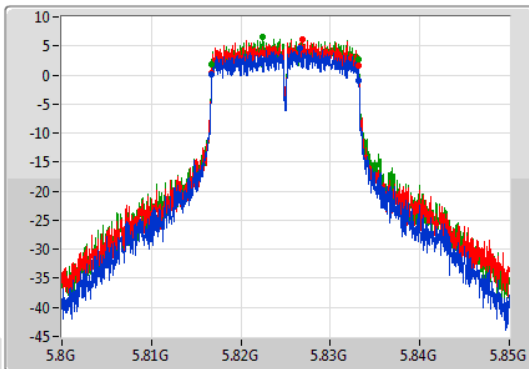

CF
5.825GHz
Span
50MHz
RBW
200kHz
VBW
1MHz
Sweep Time
100ms
Detector Type
Sample

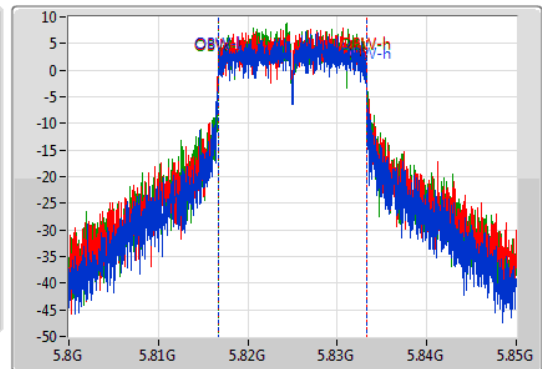

6dB(Hz)	Fl-6dB(Hz)	Fh-6dB(Hz)	OBW(Hz)	Fl-OBW(Hz)	Fh-OBW(Hz)	Limit(Hz)	Port
16.4M	5.816775G	5.833175G	16.517M	5.816704G	5.833221G	500k	1
16.425M	5.816725G	5.83315G	16.542M	5.816679G	5.833221G	500k	2
16.375M	5.816775G	5.83315G	16.542M	5.816679G	5.833221G	500k	3

802.11ac VHT20_Nss1,(MCS0)_3TX

EBW

5180MHz

31/10/2019

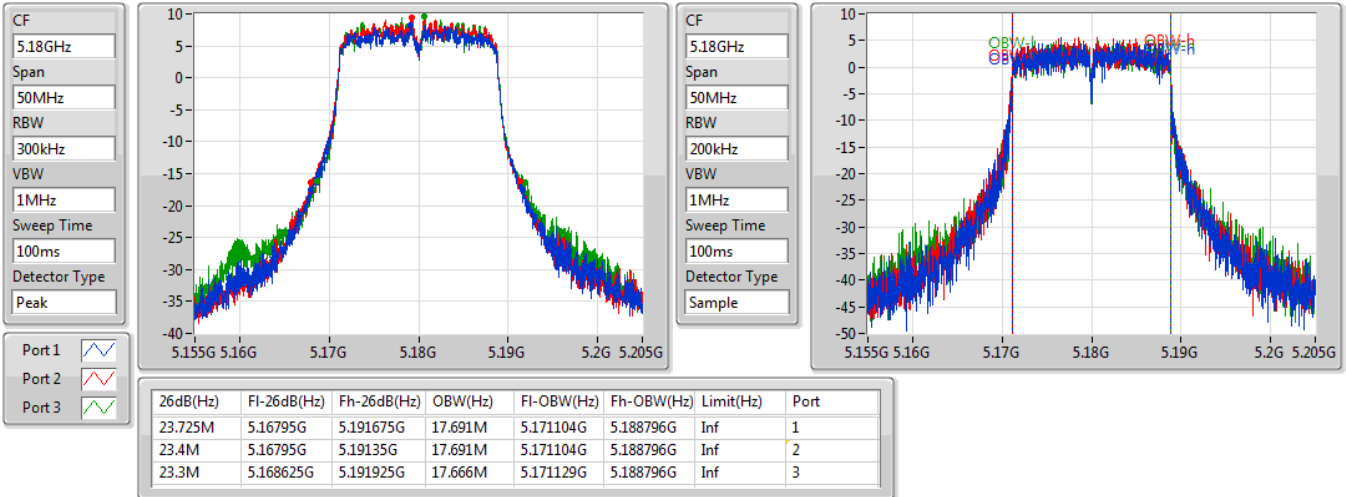

802.11ac VHT20_Nss1,(MCS0)_3TX

EBW

5200MHz

31/10/2019

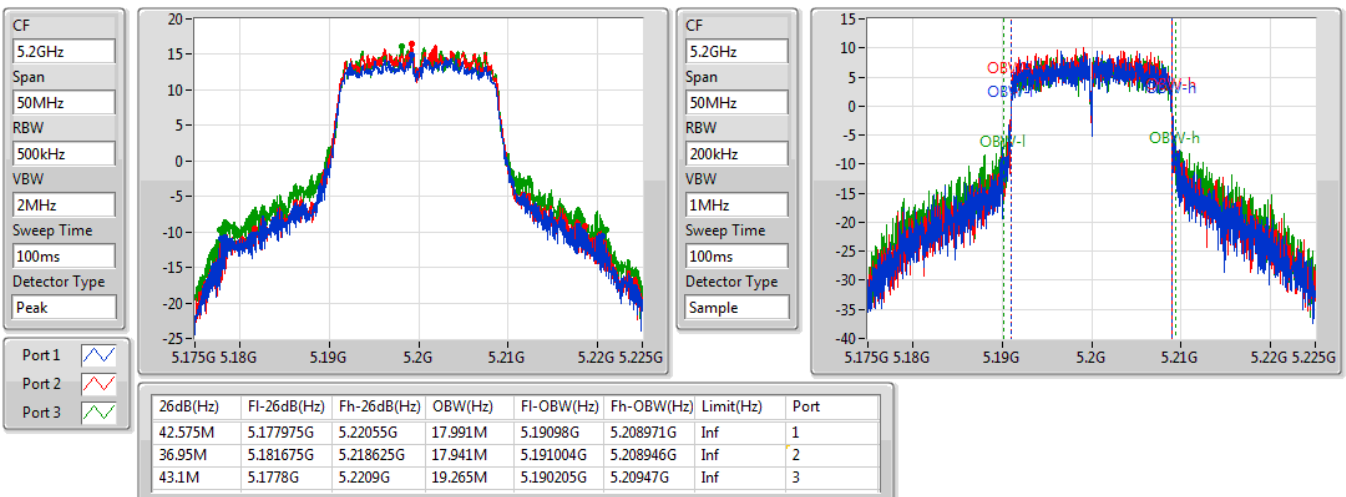

802.11ac VHT20_Nss1,(MCS0)_3TX

EBW

5240MHz

31/10/2019

CF
5.24GHz
Span
50MHz
RBW
500kHz
VBW
2MHz
Sweep Time
100ms
Detector Type
Peak

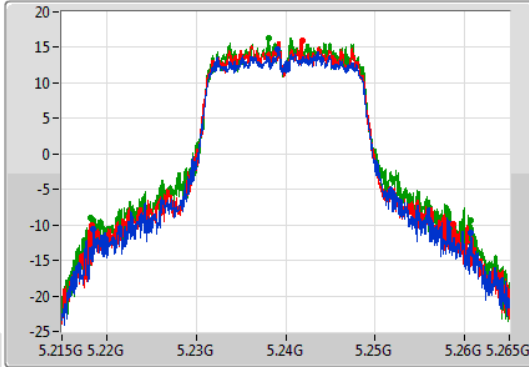

CF
5.24GHz
Span
50MHz
RBW
200kHz
VBW
1MHz
Sweep Time
100ms
Detector Type
Sample

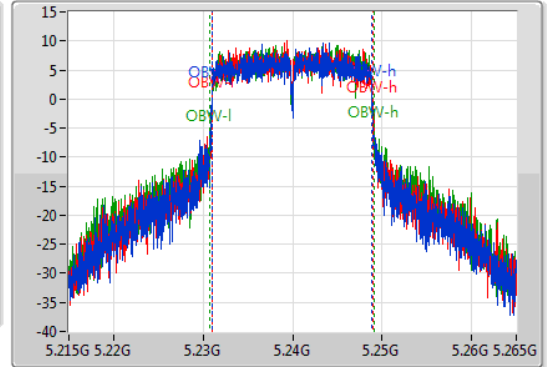

26dB(Hz)	Fl-26dB(Hz)	Fh-26dB(Hz)	OBW(Hz)	Fl-OBW(Hz)	Fh-OBW(Hz)	Limit(Hz)	Port
42.2M	5.21845G	5.26065G	17.941M	5.230955G	5.248896G	Inf	1
40.5M	5.218275G	5.258775G	17.941M	5.23098G	5.248921G	Inf	2
42.4M	5.218225G	5.260625G	18.341M	5.230805G	5.249145G	Inf	3

802.11ac VHT20_Nss1,(MCS0)_3TX

EBW

5745MHz

01/11/2019

CF
5.745GHz
Span
50MHz
RBW
100kHz
VBW
300kHz
Sweep Time
100ms
Detector Type
Peak

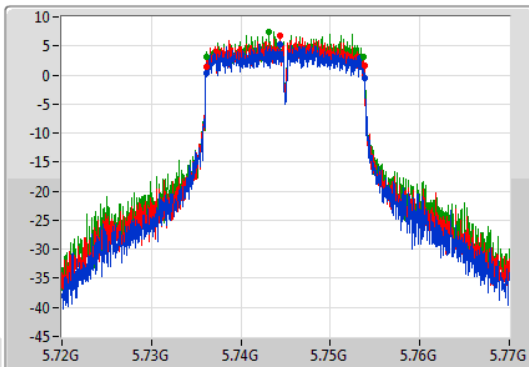

CF
5.745GHz
Span
50MHz
RBW
200kHz
VBW
1MHz
Sweep Time
100ms
Detector Type
Sample

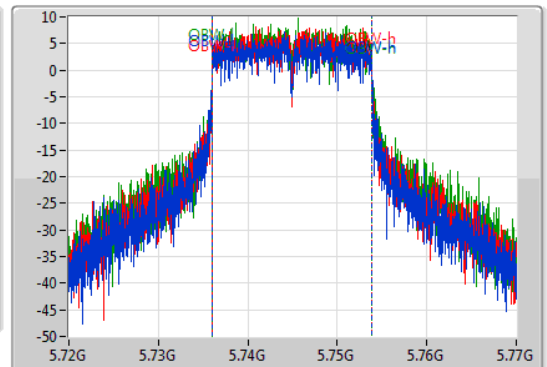

6dB(Hz)	Fl-6dB(Hz)	Fh-6dB(Hz)	OBW(Hz)	Fl-OBW(Hz)	Fh-OBW(Hz)	Limit(Hz)	Port
17.725M	5.7361G	5.753825G	17.741M	5.736079G	5.753821G	500k	1
17.625M	5.73615G	5.753775G	17.716M	5.736079G	5.753796G	500k	2
17.575M	5.736175G	5.75375G	17.766M	5.736079G	5.753846G	500k	3

802.11ac VHT20_Nss1,(MCS0)_3TX

EBW

5785MHz

01/11/2019

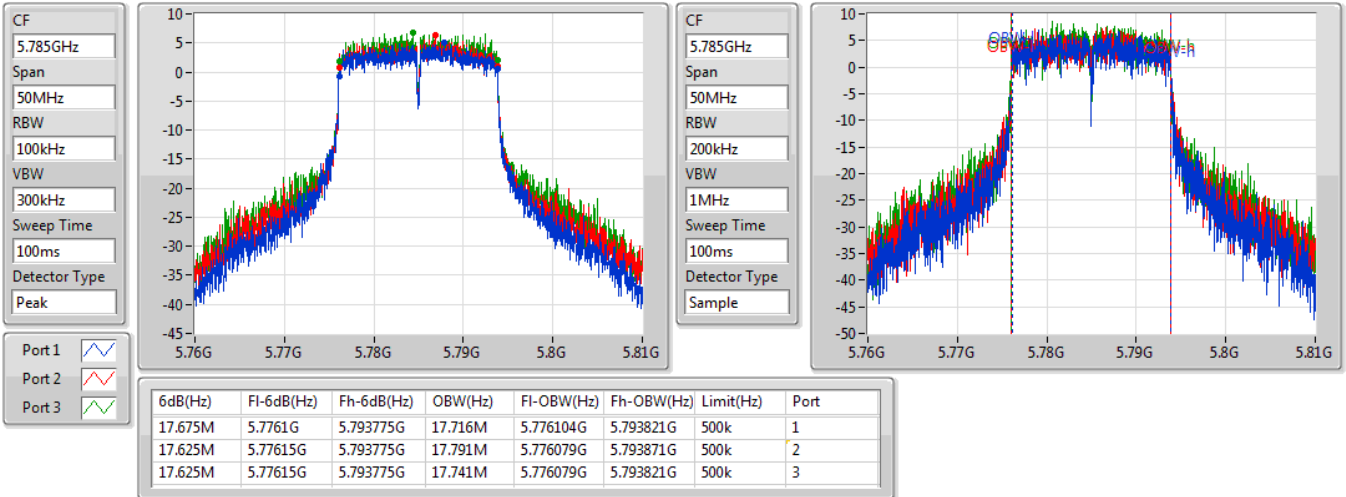

802.11ac VHT20_Nss1,(MCS0)_3TX

EBW

5825MHz

01/11/2019

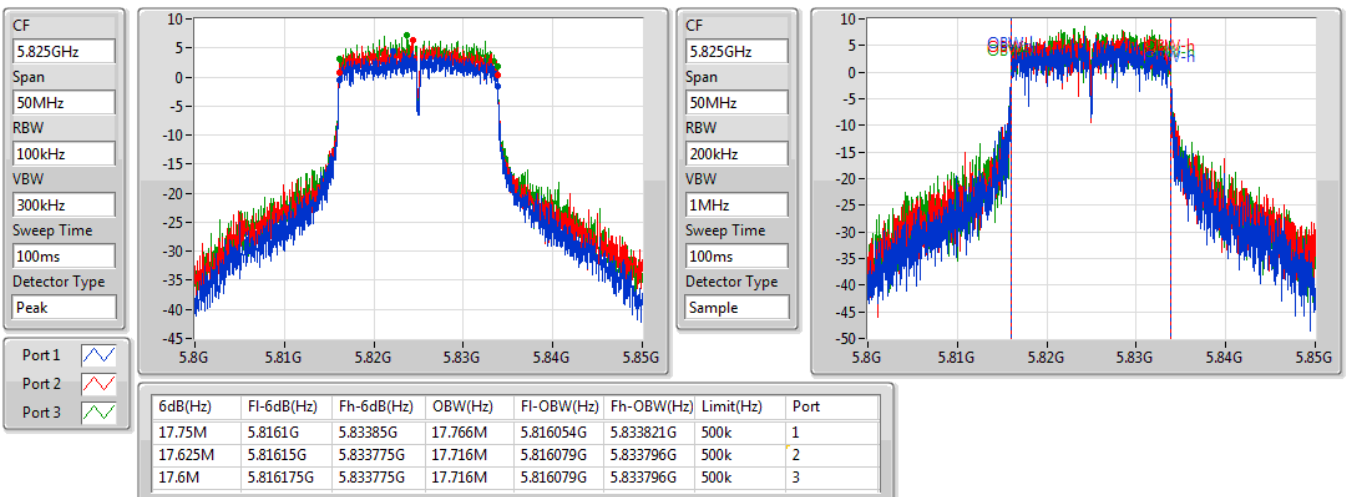

802.11ac VHT40_Nss1,(MCS0)_3TX

EBW

5190MHz

31/10/2019

CF
5.19GHz
Span
100MHz
RBW
500kHz
VBW
2MHz
Sweep Time
100ms
Detector Type
Peak

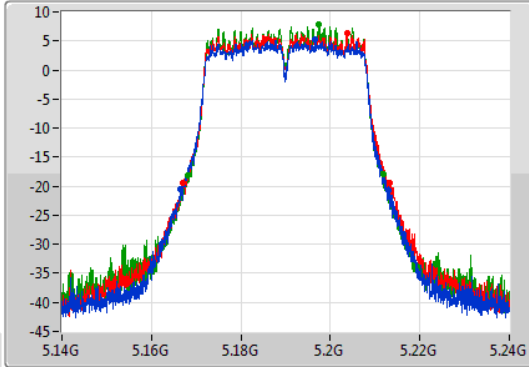

CF
5.19GHz
Span
100MHz
RBW
500kHz
VBW
2MHz
Sweep Time
100ms
Detector Type
Sample

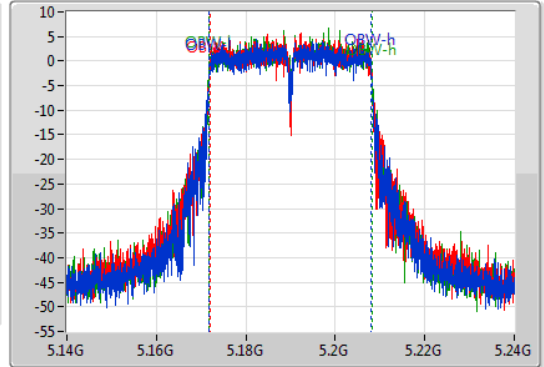

26dB(Hz)	Fl-26dB(Hz)	Fh-26dB(Hz)	OBW(Hz)	Fl-OBW(Hz)	Fh-OBW(Hz)	Limit(Hz)	Port
46.5M	5.1666G	5.2131G	36.132M	5.171859G	5.207991G	Inf	1
46M	5.16715G	5.21315G	36.132M	5.171909G	5.208041G	Inf	2
43.7M	5.1682G	5.2119G	36.282M	5.171859G	5.208141G	Inf	3

802.11ac VHT40_Nss1,(MCS0)_3TX

EBW

5230MHz

31/10/2019

CF
5.23GHz
Span
100MHz
RBW
1MHz
VBW
3MHz
Sweep Time
100ms
Detector Type
Peak

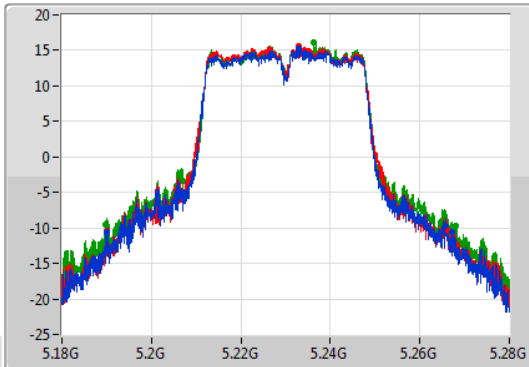

CF
5.23GHz
Span
100MHz
RBW
500kHz
VBW
2MHz
Sweep Time
100ms
Detector Type
Sample



26dB(Hz)	Fl-26dB(Hz)	Fh-26dB(Hz)	OBW(Hz)	Fl-OBW(Hz)	Fh-OBW(Hz)	Limit(Hz)	Port
77M	5.19015G	5.26715G	36.532M	5.211659G	5.248191G	Inf	1
76.5M	5.18995G	5.26645G	36.482M	5.211659G	5.248141G	Inf	2
78.25M	5.18965G	5.2679G	36.832M	5.211459G	5.248291G	Inf	3

802.11ac VHT40_Nss1,(MCS0)_3TX

EBW

5755MHz

01/11/2019

CF
5.755GHz
Span
100MHz
RBW
100kHz
VBW
300kHz
Sweep Time
100ms
Detector Type
Peak

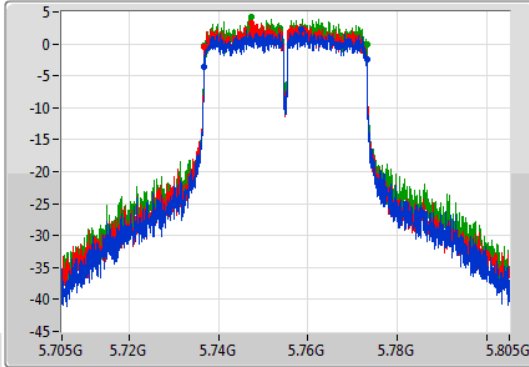

CF
5.755GHz
Span
100MHz
RBW
500kHz
VBW
2MHz
Sweep Time
100ms
Detector Type
Sample

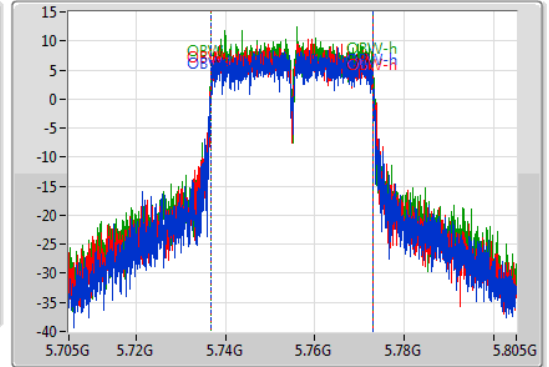

6dB(Hz)	Fl-6dB(Hz)	Fh-6dB(Hz)	OBW(Hz)	Fl-OBW(Hz)	Fh-OBW(Hz)	Limit(Hz)	Port
36.4M	5.73675G	5.77315G	36.232M	5.736809G	5.773041G	500k	1
36.35M	5.7368G	5.77315G	36.232M	5.736809G	5.773041G	500k	2
36.35M	5.7368G	5.77315G	36.282M	5.736809G	5.773091G	500k	3

802.11ac VHT40_Nss1,(MCS0)_3TX

EBW

5795MHz

01/11/2019

CF
5.795GHz
Span
100MHz
RBW
100kHz
VBW
300kHz
Sweep Time
100ms
Detector Type
Peak

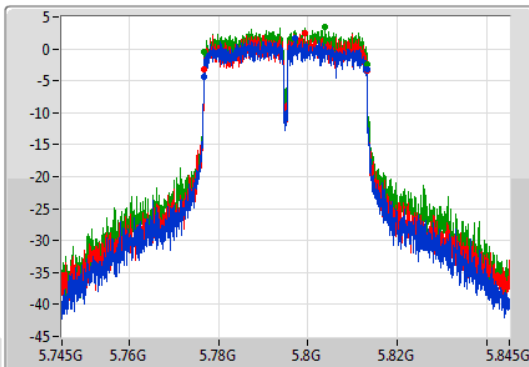

CF
5.795GHz
Span
100MHz
RBW
500kHz
VBW
2MHz
Sweep Time
100ms
Detector Type
Sample

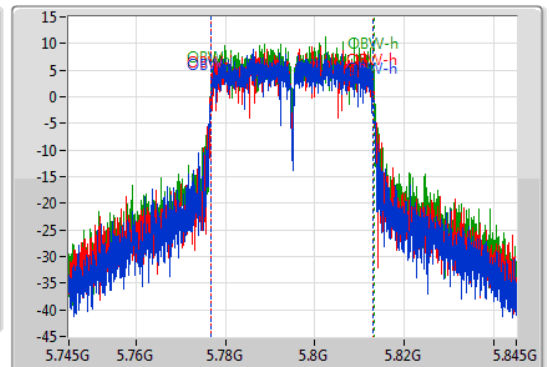

6dB(Hz)	Fl-6dB(Hz)	Fh-6dB(Hz)	OBW(Hz)	Fl-OBW(Hz)	Fh-OBW(Hz)	Limit(Hz)	Port
36.4M	5.77675G	5.81315G	36.182M	5.776809G	5.812991G	500k	1
36.4M	5.7768G	5.8132G	36.232M	5.776809G	5.813041G	500k	2
36.4M	5.7768G	5.8132G	36.332M	5.776809G	5.813141G	500k	3

802.11ac VHT80_Nss1,(MCS0)_3TX

EBW

5210MHz

31/10/2019

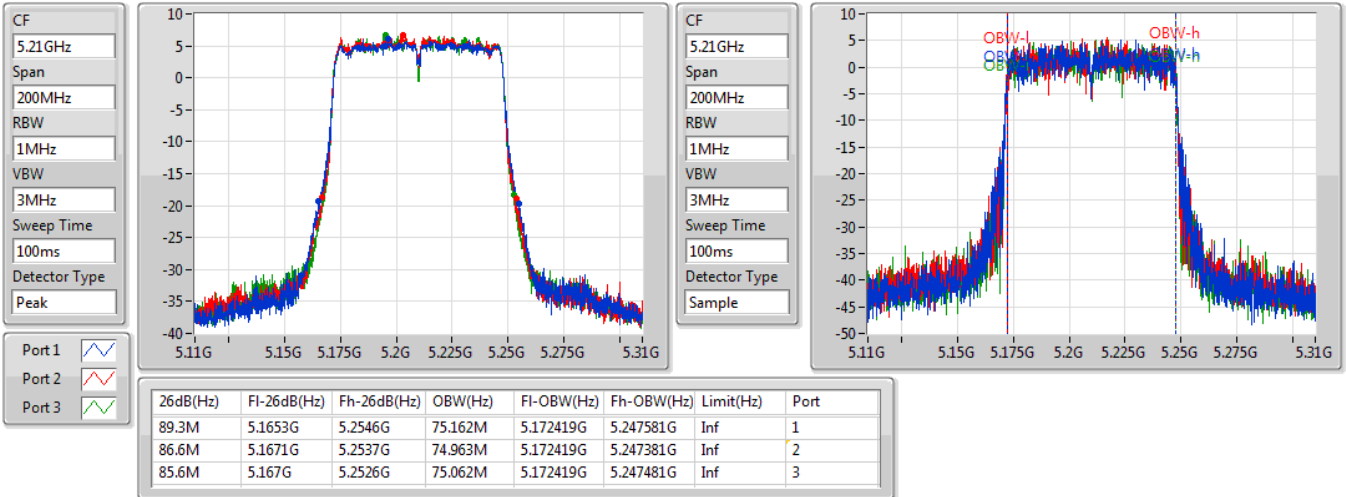

802.11ac VHT80_Nss1,(MCS0)_3TX

EBW

5775MHz

01/11/2019

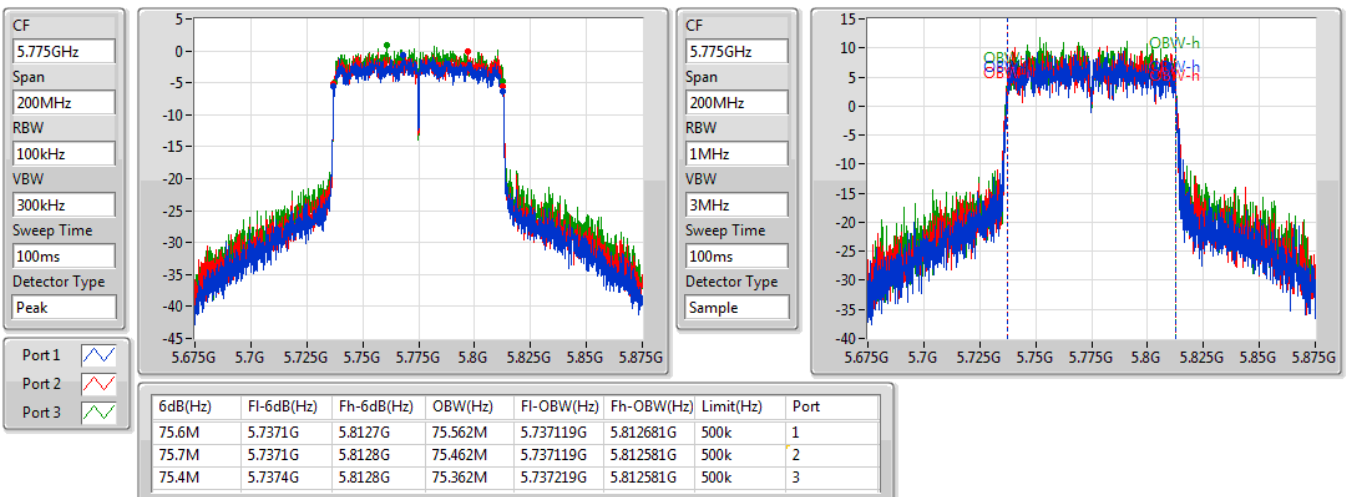



Average Power Result

Appendix C

Summary

Mode	Total Power (dBm)	Total Power (W)
5.15-5.25GHz	-	-
802.11a_Nss1,(6Mbps)_3TX	26.32	0.42855
802.11ac VHT20_Nss1,(MCS0)_3TX	26.08	0.40551
802.11ac VHT40_Nss1,(MCS0)_3TX	25.95	0.39355
802.11ac VHT80_Nss1,(MCS0)_3TX	19.88	0.09727
5.725-5.85GHz	-	-
802.11a_Nss1,(6Mbps)_3TX	25.01	0.31696
802.11ac VHT20_Nss1,(MCS0)_3TX	25.21	0.33189
802.11ac VHT40_Nss1,(MCS0)_3TX	25.14	0.32659
802.11ac VHT80_Nss1,(MCS0)_3TX	24.89	0.30832



Average Power Result

Result

Mode	Result	DG (dBi)	Port 1 (dBm)	Port 2 (dBm)	Port 3 (dBm)	Total Power (dBm)	Power Limit (dBm)
802.11a_Nss1,(6Mbps)_3TX	-	-	-	-	-	-	-
5180MHz	Pass	3.40	17.41	17.87	17.70	22.44	30.00
5200MHz	Pass	3.40	21.29	21.93	21.39	26.32	30.00
5240MHz	Pass	3.40	21.19	21.58	21.53	26.21	30.00
5745MHz	Pass	3.40	19.42	20.31	20.87	25.01	30.00
5785MHz	Pass	3.40	19.16	19.59	20.34	24.50	30.00
5825MHz	Pass	3.40	19.07	19.82	20.34	24.55	30.00
802.11ac_VHT20_Nss1,(MCS0)_3TX	-	-	-	-	-	-	-
5180MHz	Pass	3.40	16.83	17.37	17.29	21.94	30.00
5200MHz	Pass	3.40	20.98	21.65	21.27	26.08	30.00
5240MHz	Pass	3.40	20.96	21.36	21.46	26.04	30.00
5745MHz	Pass	3.40	19.53	20.51	21.12	25.21	30.00
5785MHz	Pass	3.40	19.21	19.61	20.55	24.60	30.00
5825MHz	Pass	3.40	19.23	19.68	20.45	24.59	30.00
802.11ac_VHT40_Nss1,(MCS0)_3TX	-	-	-	-	-	-	-
5190MHz	Pass	3.40	15.06	15.67	15.58	20.22	30.00
5230MHz	Pass	3.40	20.94	21.38	21.20	25.95	30.00
5755MHz	Pass	3.40	19.61	20.35	21.03	25.14	30.00
5795MHz	Pass	3.40	19.06	19.78	20.48	24.58	30.00
802.11ac_VHT80_Nss1,(MCS0)_3TX	-	-	-	-	-	-	-
5210MHz	Pass	3.40	14.97	15.22	15.13	19.88	30.00
5775MHz	Pass	3.40	19.48	20.00	20.79	24.89	30.00

DG = Directional Gain; Port X = Port X output power



Summary

Mode	PD (dBm/RBW)
5.15-5.25GHz	-
802.11a_Nss1,(6Mbps)_3TX	13.80
802.11ac VHT20_Nss1,(MCS0)_3TX	13.25
802.11ac VHT40_Nss1,(MCS0)_3TX	9.99
802.11ac VHT80_Nss1,(MCS0)_3TX	0.82
5.725-5.85GHz	-
802.11a_Nss1,(6Mbps)_3TX	11.06
802.11ac VHT20_Nss1,(MCS0)_3TX	10.99
802.11ac VHT40_Nss1,(MCS0)_3TX	7.82
802.11ac VHT80_Nss1,(MCS0)_3TX	4.34

RBW = 500 kHz for 5.725-5.85GHz band / 1MHz for other band;

Result

Mode	Result	DG (dBi)	Port 1 (dBm/RBW)	Port 2 (dBm/RBW)	Port 3 (dBm/RBW)	PD (dBm/RBW)	PD Limit (dBm/RBW)
802.11a_Nss1,(6Mbps)_3TX	-	-	-	-	-	-	-
5180MHz	Pass	8.17	4.89	5.24	5.14	9.83	14.83
5200MHz	Pass	8.17	8.81	9.35	9.03	13.80	14.83
5240MHz	Pass	8.17	8.74	8.91	9.06	13.63	14.83
5745MHz	Pass	8.17	5.47	6.53	6.93	11.06	27.83
5785MHz	Pass	8.17	5.31	5.72	6.38	10.47	27.83
5825MHz	Pass	8.17	4.68	5.89	6.51	10.35	27.83
802.11ac VHT20_Nss1,(MCS0)_3TX	-	-	-	-	-	-	-
5180MHz	Pass	8.17	4.30	4.73	4.75	9.29	14.83
5200MHz	Pass	8.17	8.20	8.87	8.62	13.25	14.83
5240MHz	Pass	8.17	8.20	8.46	8.80	13.18	14.83
5745MHz	Pass	8.17	5.31	6.46	6.87	10.99	27.83
5785MHz	Pass	8.17	4.99	5.51	6.36	10.36	27.83
5825MHz	Pass	8.17	4.36	5.49	6.26	10.13	27.83
802.11ac VHT40_Nss1,(MCS0)_3TX	-	-	-	-	-	-	-
5190MHz	Pass	8.17	-0.78	-0.20	-0.24	4.27	14.83
5230MHz	Pass	8.17	5.06	5.50	5.40	9.99	14.83
5755MHz	Pass	8.17	2.27	3.17	3.82	7.82	27.83
5795MHz	Pass	8.17	1.92	2.81	3.34	7.34	27.83
802.11ac VHT80_Nss1,(MCS0)_3TX	-	-	-	-	-	-	-
5210MHz	Pass	8.17	-3.99	-3.70	-3.91	0.82	14.83
5775MHz	Pass	8.17	-0.79	-0.46	0.36	4.34	27.83

DG = Directional Gain; **RBW** = 500 kHz for 5.725-5.85GHz band / 1MHz for other band;

PD = trace bin-by-bin of each transmits port summing can be performed maximum power density; **Port X** = Port X power density;

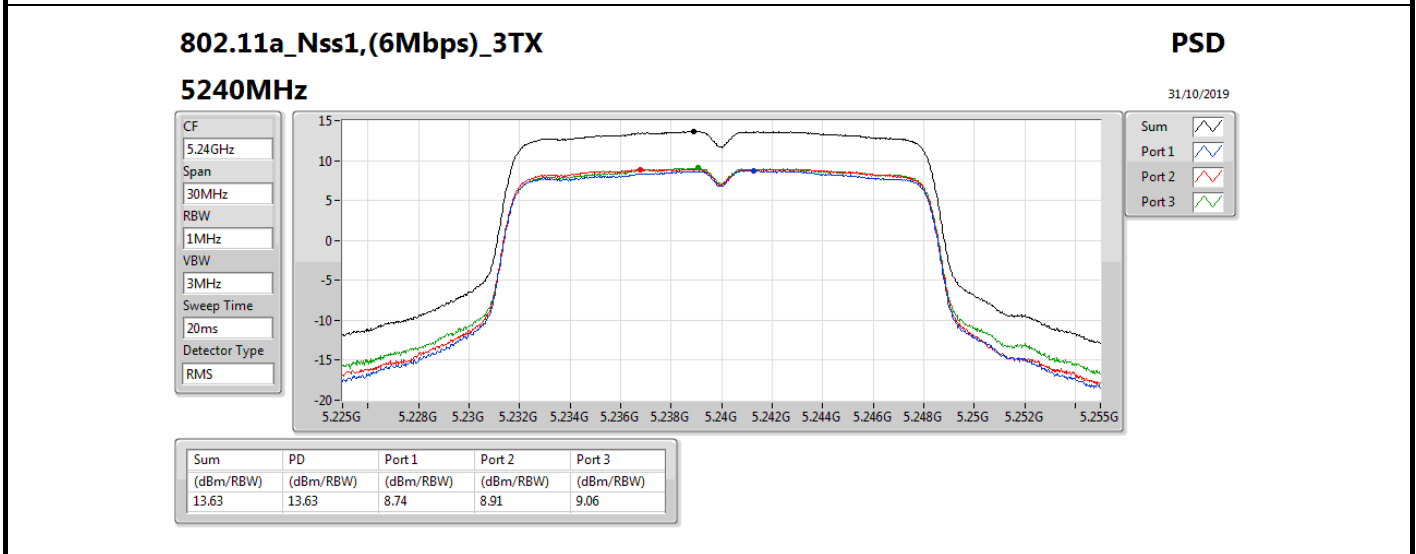
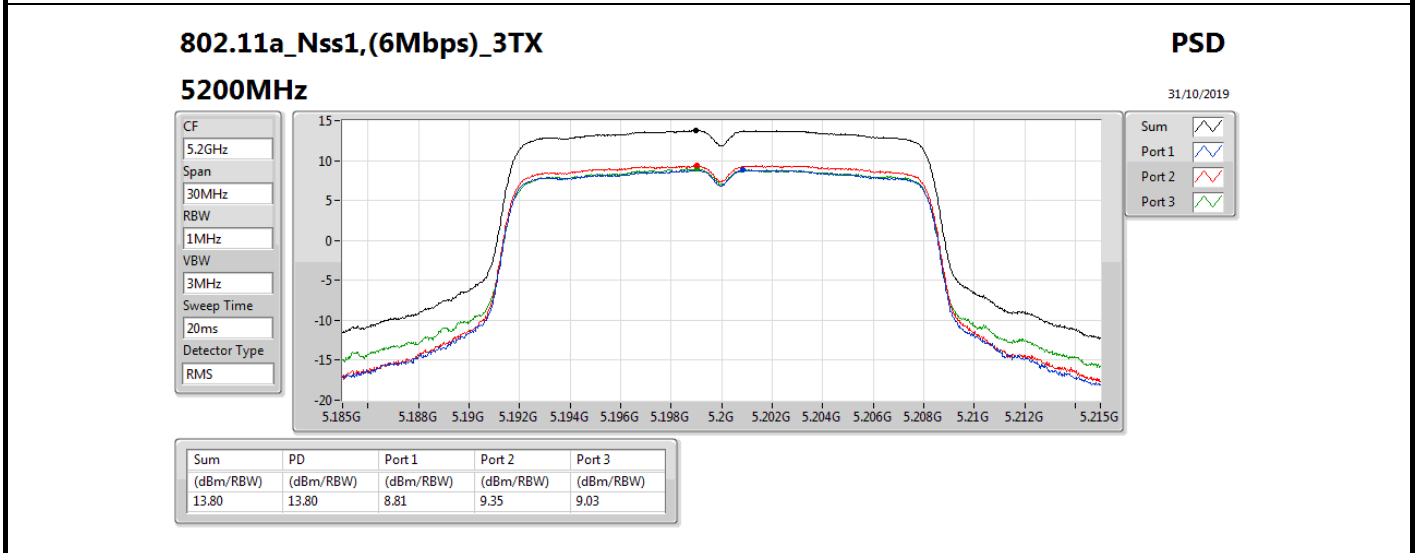
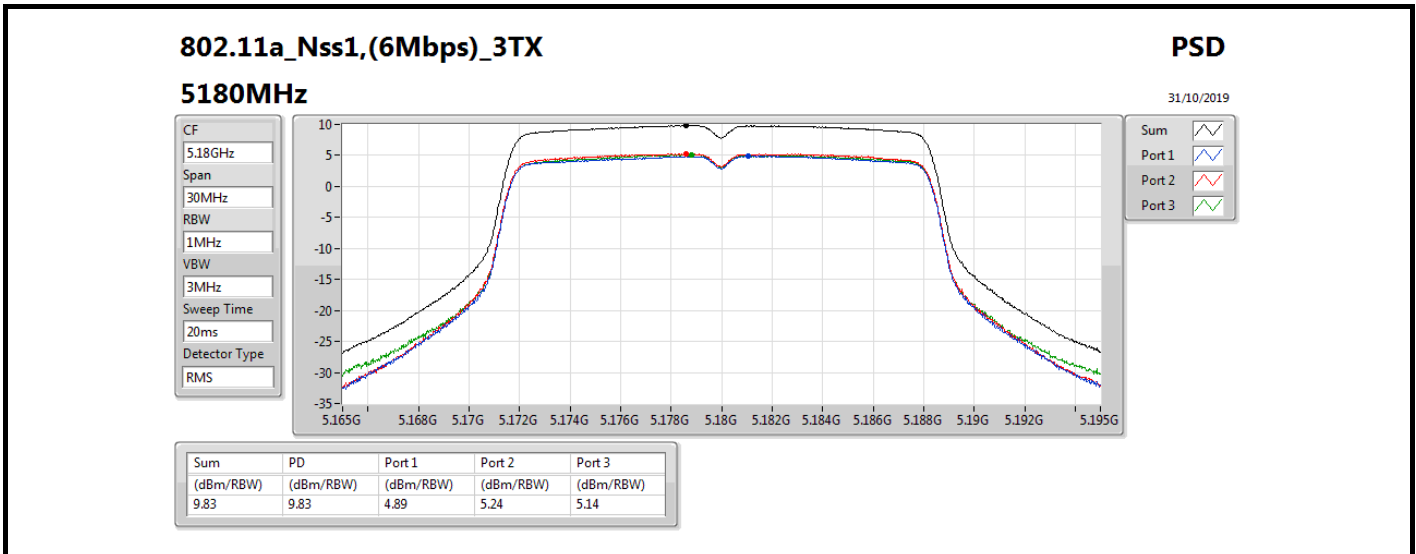

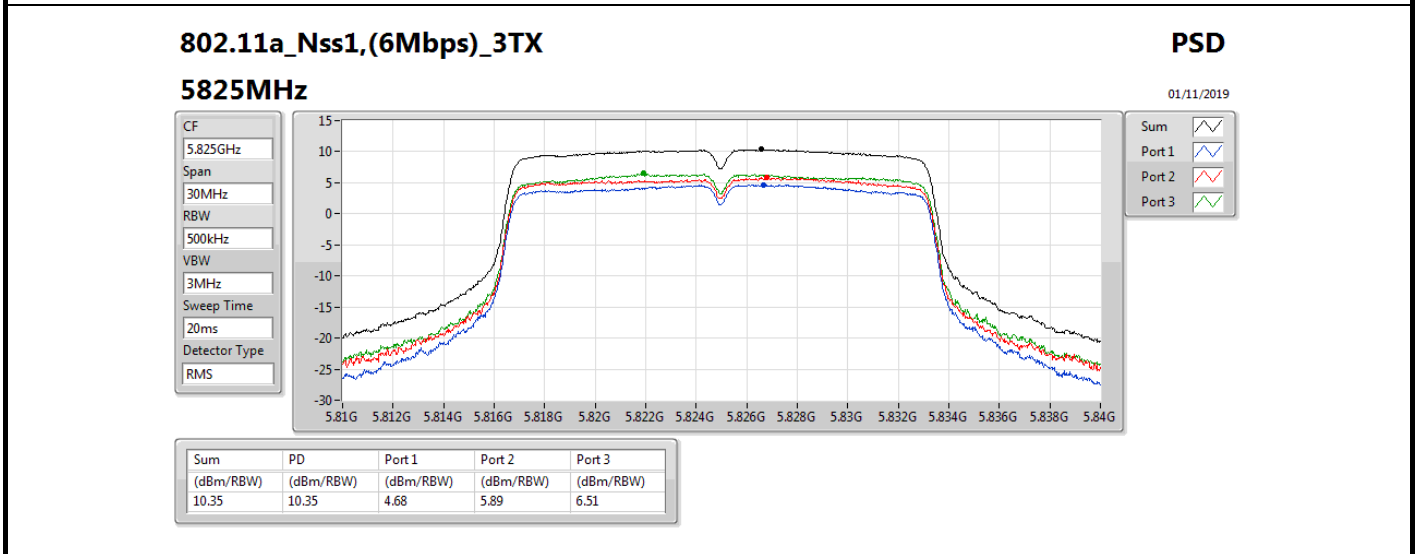
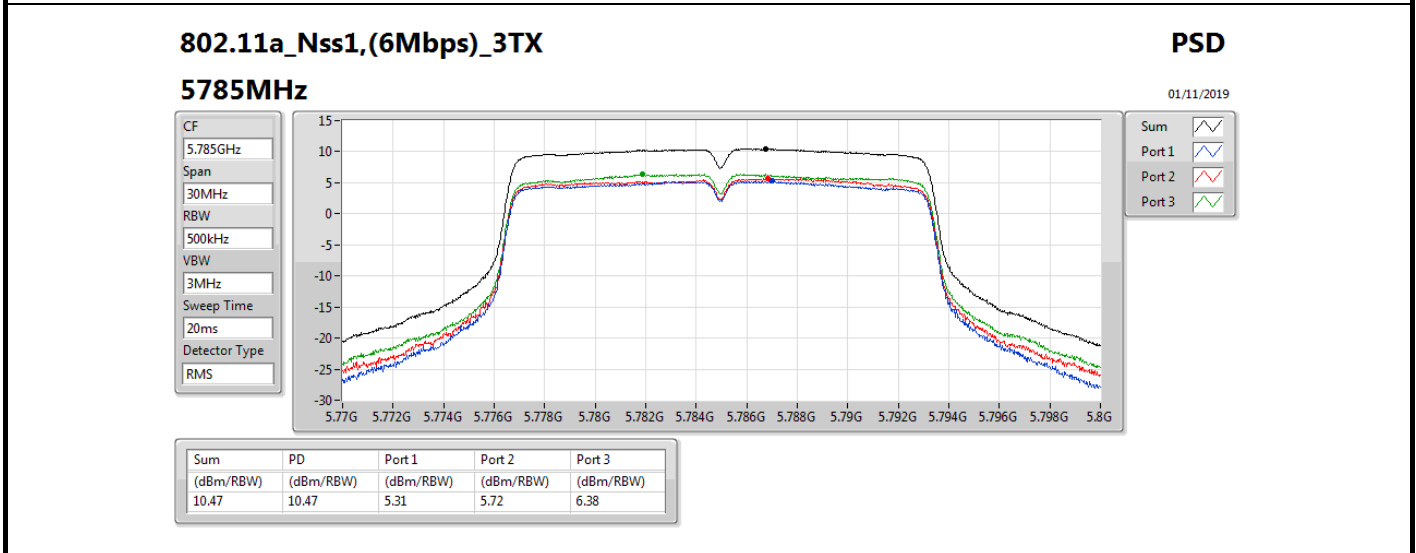
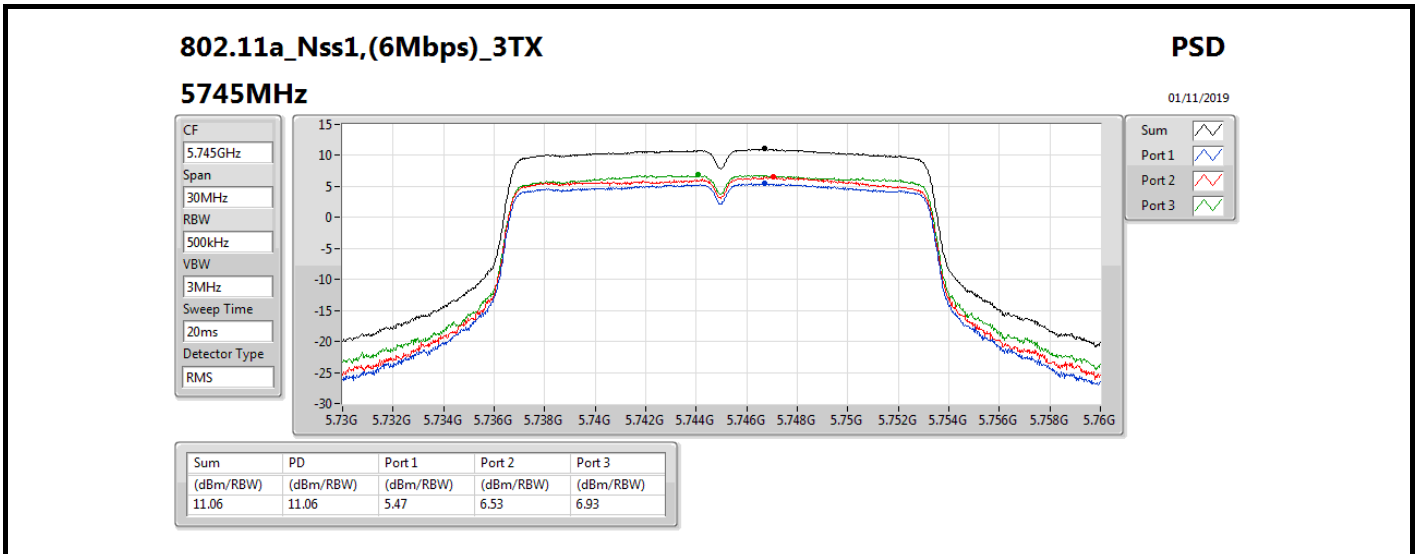

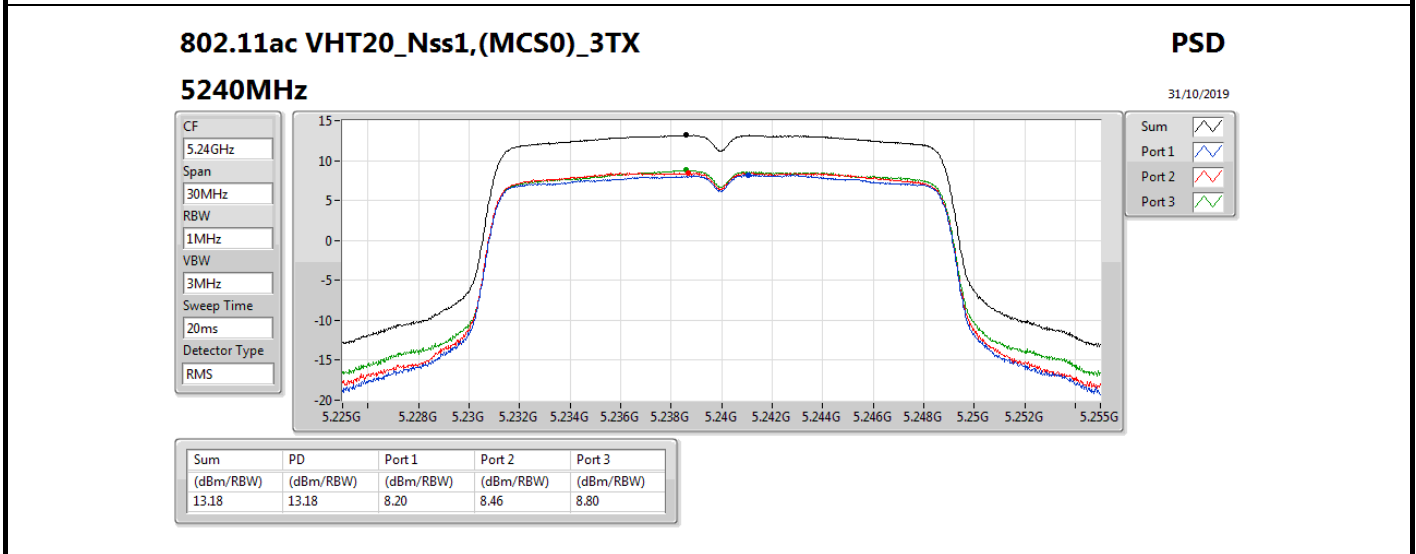
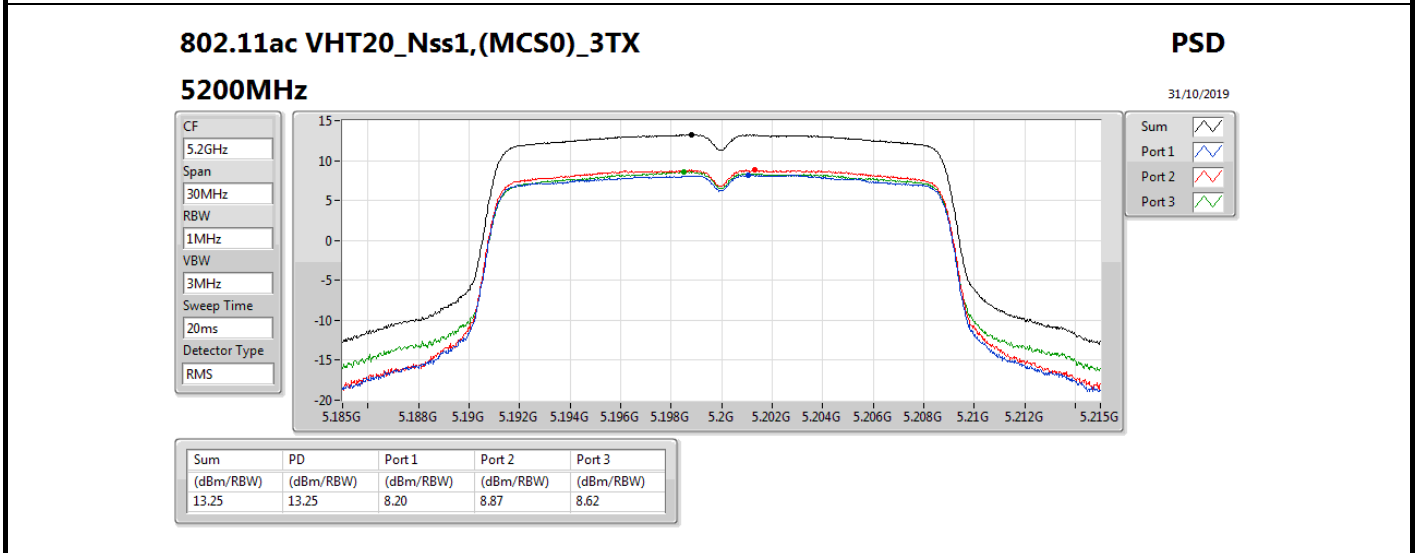
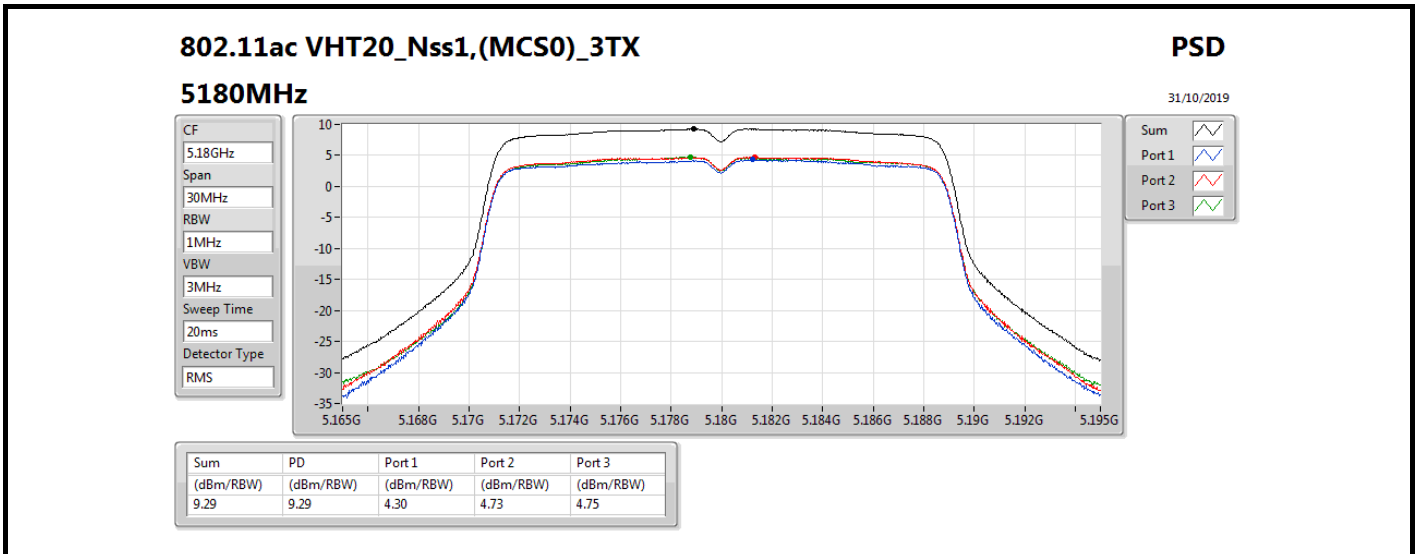

802.11ac VHT20_Nss1,(MCS0)_3TX

PSD

5745MHz

01/11/2019

CF
5.745GHz
Span
30MHz
RBW
500kHz
VBW
3MHz
Sweep Time
20ms
Detector Type
RMS

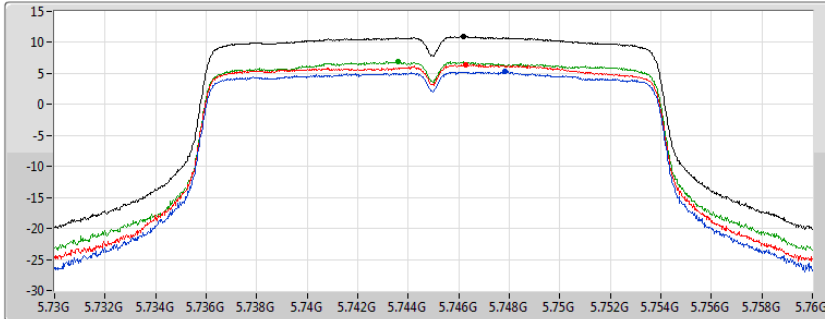

Sum
Port 1
Port 2
Port 3

Sum	PD	Port 1	Port 2	Port 3
(dBm/RBW)	(dBm/RBW)	(dBm/RBW)	(dBm/RBW)	(dBm/RBW)
10.99	10.99	5.31	6.46	6.87

802.11ac VHT20_Nss1,(MCS0)_3TX

PSD

5785MHz

01/11/2019

CF
5.785GHz
Span
30MHz
RBW
500kHz
VBW
3MHz
Sweep Time
20ms
Detector Type
RMS

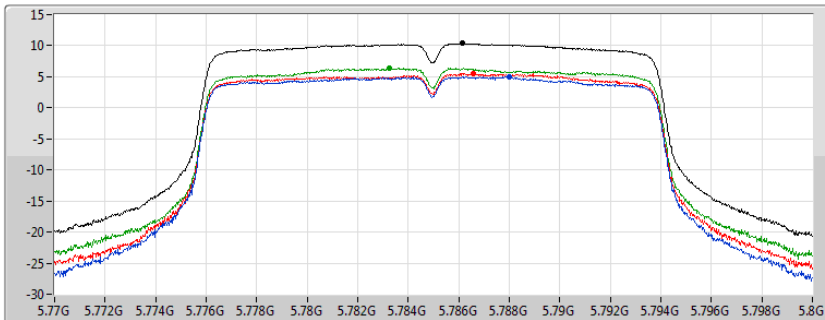

Sum
Port 1
Port 2
Port 3

Sum	PD	Port 1	Port 2	Port 3
(dBm/RBW)	(dBm/RBW)	(dBm/RBW)	(dBm/RBW)	(dBm/RBW)
10.36	10.36	4.99	5.51	6.36

802.11ac VHT20_Nss1,(MCS0)_3TX

PSD

5825MHz

01/11/2019

CF
5.825GHz
Span
30MHz
RBW
500kHz
VBW
3MHz
Sweep Time
20ms
Detector Type
RMS

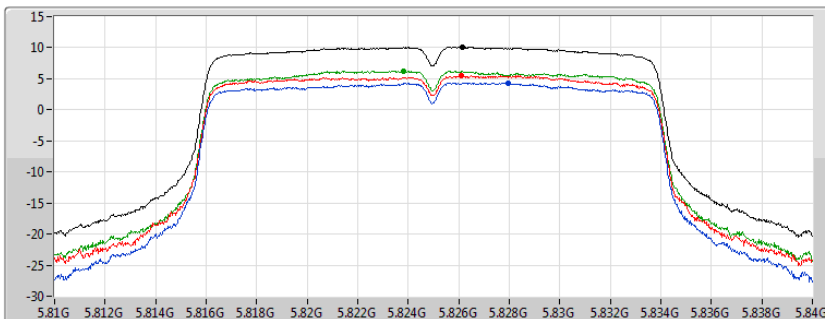

Sum
Port 1
Port 2
Port 3

Sum	PD	Port 1	Port 2	Port 3
(dBm/RBW)	(dBm/RBW)	(dBm/RBW)	(dBm/RBW)	(dBm/RBW)
10.13	10.13	4.36	5.49	6.26

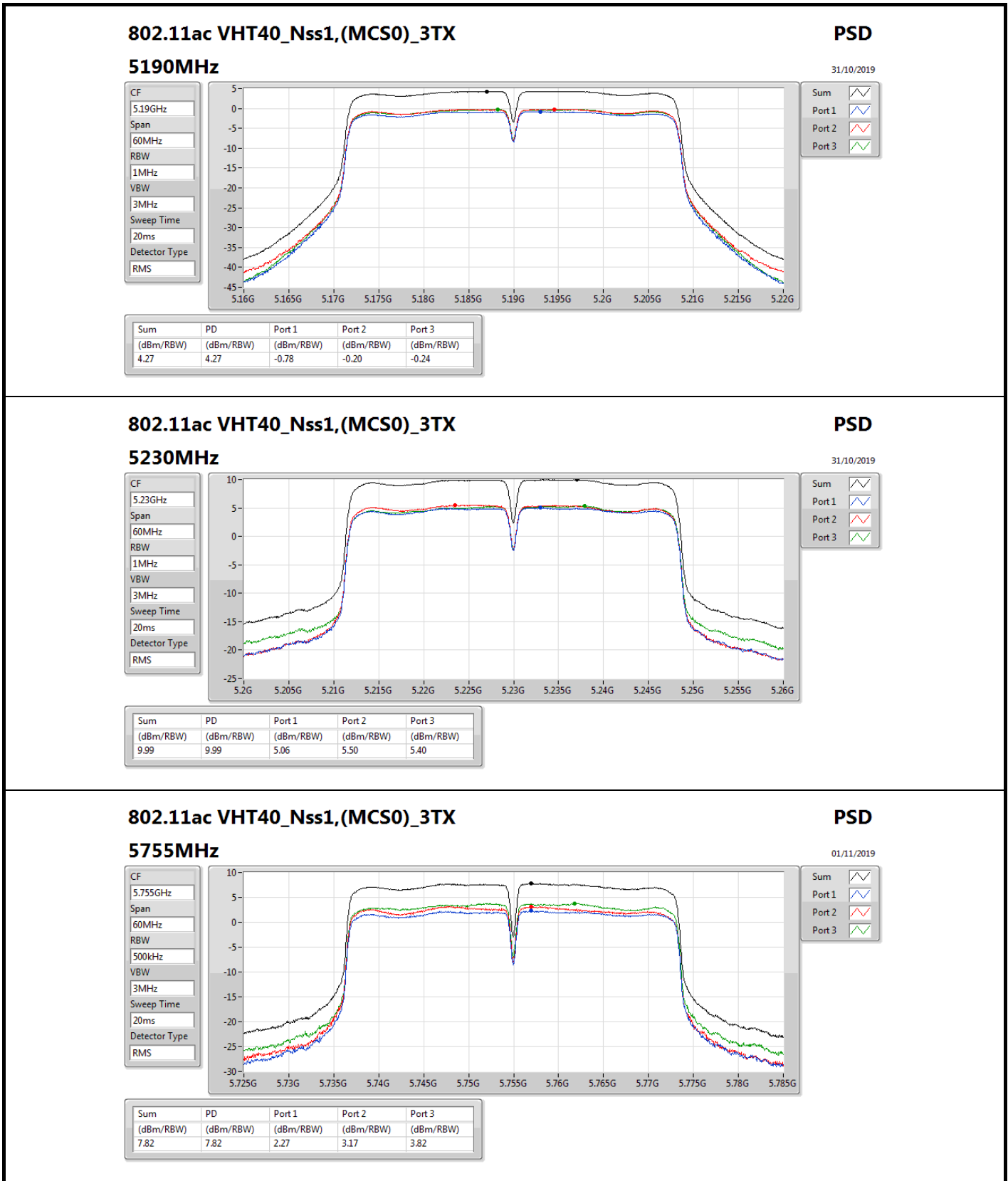

802.11ac VHT40_Nss1,(MCS0)_3TX

PSD

5795MHz

01/11/2019

CF
5.795GHz
Span
60MHz
RBW
500kHz
VBW
3MHz
Sweep Time
20ms
Detector Type
RMS

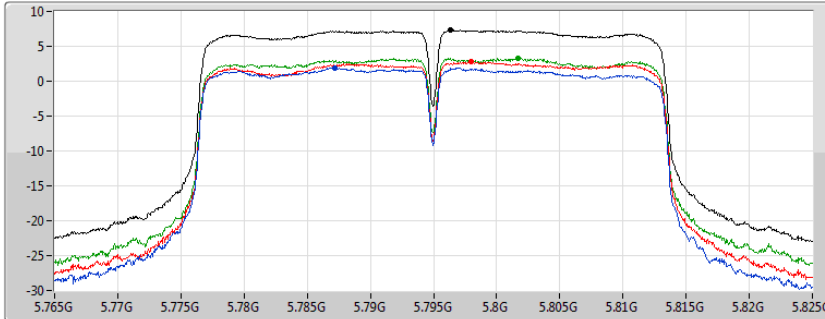

Sum
Port 1
Port 2
Port 3

Sum	PD	Port 1	Port 2	Port 3
(dBm/RBW)	(dBm/RBW)	(dBm/RBW)	(dBm/RBW)	(dBm/RBW)
7.34	7.34	1.92	2.81	3.34

802.11ac VHT80_Nss1,(MCS0)_3TX

PSD

5210MHz

31/10/2019

CF
5.21GHz
Span
120MHz
RBW
1MHz
VBW
3MHz
Sweep Time
20ms
Detector Type
RMS

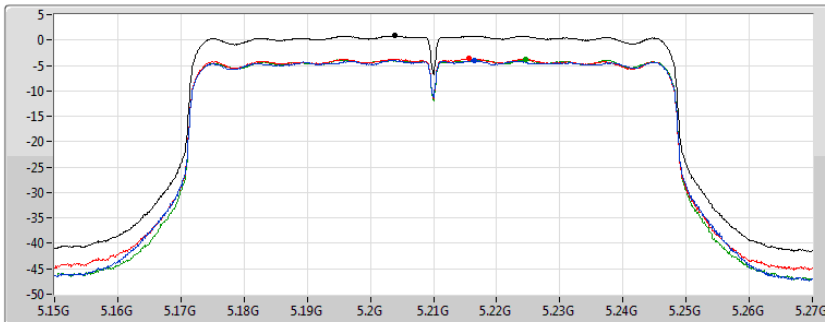

Sum
Port 1
Port 2
Port 3

Sum	PD	Port 1	Port 2	Port 3
(dBm/RBW)	(dBm/RBW)	(dBm/RBW)	(dBm/RBW)	(dBm/RBW)
0.82	0.82	-3.99	-3.70	-3.91

802.11ac VHT80_Nss1,(MCS0)_3TX

PSD

5775MHz

01/11/2019

CF
5.775GHz
Span
120MHz
RBW
500kHz
VBW
3MHz
Sweep Time
20ms
Detector Type
RMS

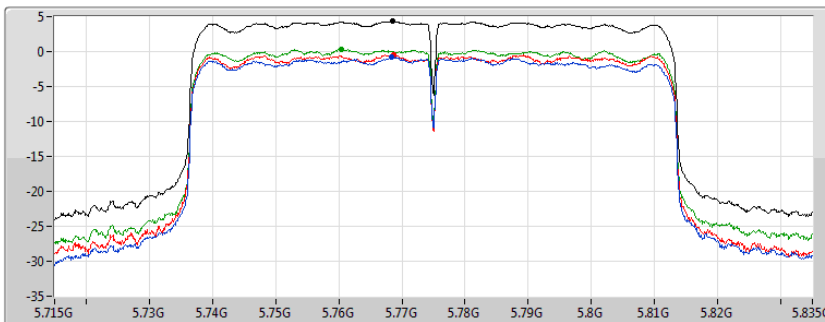

Sum
Port 1
Port 2
Port 3

Sum	PD	Port 1	Port 2	Port 3
(dBm/RBW)	(dBm/RBW)	(dBm/RBW)	(dBm/RBW)	(dBm/RBW)
4.34	4.34	-0.79	-0.46	0.36



RSE below 1GHz Result

Appendix E.1

RSE below 1GHz Result																																																																																																									
Operating Mode	1	Polarization	Vertical																																																																																																						
Operating Function	Normal Link																																																																																																								
<div style="display: flex; justify-content: space-between; align-items: flex-start;"> <div style="text-align: center;"> <p style="font-size: small;">Date: 2019-10-28 Time: 16:38:29</p> </div> </div>																																																																																																									
<table border="1" style="width: 100%; border-collapse: collapse; font-size: x-small;"> <thead> <tr> <th></th> <th>Freq</th> <th>Level</th> <th>Limit</th> <th>Over</th> <th>Read</th> <th>CableAntenna</th> <th>Preamp</th> <th>A/Pos</th> <th>T/Pos</th> <th>Remark</th> <th>Pol/Phase</th> </tr> <tr> <th></th> <th>MHz</th> <th>dBuV/m</th> <th>dBuV/m</th> <th>dB</th> <th>dBuV</th> <th>dB</th> <th>dB/m</th> <th>dB</th> <th>cm</th> <th>deg</th> <th></th> </tr> </thead> <tbody> <tr> <td>1</td> <td>41.64</td> <td>36.10</td> <td>40.00</td> <td>-3.90</td> <td>50.28</td> <td>0.63</td> <td>17.41</td> <td>32.22</td> <td>100</td> <td>336</td> <td>Peak</td> <td>VERTICAL</td> </tr> <tr> <td>2</td> <td>52.31</td> <td>35.84</td> <td>40.00</td> <td>-4.16</td> <td>54.20</td> <td>0.74</td> <td>13.08</td> <td>32.18</td> <td>100</td> <td>359</td> <td>QP</td> <td>VERTICAL</td> </tr> <tr> <td>3</td> <td>71.71</td> <td>39.38</td> <td>40.00</td> <td>-0.62</td> <td>58.60</td> <td>0.86</td> <td>12.06</td> <td>32.14</td> <td>100</td> <td>97</td> <td>QP</td> <td>VERTICAL</td> </tr> <tr> <td>4</td> <td>82.38</td> <td>36.68</td> <td>40.00</td> <td>-3.32</td> <td>54.80</td> <td>0.92</td> <td>13.07</td> <td>32.11</td> <td>125</td> <td>252</td> <td>QP</td> <td>VERTICAL</td> </tr> <tr> <td>5</td> <td>624.61</td> <td>40.28</td> <td>46.00</td> <td>-5.72</td> <td>44.47</td> <td>2.66</td> <td>25.21</td> <td>32.06</td> <td>100</td> <td>259</td> <td>Peak</td> <td>VERTICAL</td> </tr> <tr> <td>6</td> <td>759.44</td> <td>42.48</td> <td>46.00</td> <td>-3.52</td> <td>45.87</td> <td>2.95</td> <td>25.66</td> <td>32.00</td> <td>100</td> <td>326</td> <td>Peak</td> <td>VERTICAL</td> </tr> </tbody> </table>					Freq	Level	Limit	Over	Read	CableAntenna	Preamp	A/Pos	T/Pos	Remark	Pol/Phase		MHz	dBuV/m	dBuV/m	dB	dBuV	dB	dB/m	dB	cm	deg		1	41.64	36.10	40.00	-3.90	50.28	0.63	17.41	32.22	100	336	Peak	VERTICAL	2	52.31	35.84	40.00	-4.16	54.20	0.74	13.08	32.18	100	359	QP	VERTICAL	3	71.71	39.38	40.00	-0.62	58.60	0.86	12.06	32.14	100	97	QP	VERTICAL	4	82.38	36.68	40.00	-3.32	54.80	0.92	13.07	32.11	125	252	QP	VERTICAL	5	624.61	40.28	46.00	-5.72	44.47	2.66	25.21	32.06	100	259	Peak	VERTICAL	6	759.44	42.48	46.00	-3.52	45.87	2.95	25.66	32.00	100	326	Peak	VERTICAL
	Freq	Level	Limit	Over	Read	CableAntenna	Preamp	A/Pos	T/Pos	Remark	Pol/Phase																																																																																														
	MHz	dBuV/m	dBuV/m	dB	dBuV	dB	dB/m	dB	cm	deg																																																																																															
1	41.64	36.10	40.00	-3.90	50.28	0.63	17.41	32.22	100	336	Peak	VERTICAL																																																																																													
2	52.31	35.84	40.00	-4.16	54.20	0.74	13.08	32.18	100	359	QP	VERTICAL																																																																																													
3	71.71	39.38	40.00	-0.62	58.60	0.86	12.06	32.14	100	97	QP	VERTICAL																																																																																													
4	82.38	36.68	40.00	-3.32	54.80	0.92	13.07	32.11	125	252	QP	VERTICAL																																																																																													
5	624.61	40.28	46.00	-5.72	44.47	2.66	25.21	32.06	100	259	Peak	VERTICAL																																																																																													
6	759.44	42.48	46.00	-3.52	45.87	2.95	25.66	32.00	100	326	Peak	VERTICAL																																																																																													
<p>Note 1: ">20dB" means emission levels that exceed the level of 20 dB below the applicable limit. Note 2: "N/F" means Nothing Found emissions (No emissions were detected.)</p>																																																																																																									



RSE below 1GHz Result

RSE below 1GHz Result											
Operating Mode	1	Polarization	Horizontal								
Operating Function	Normal Link										
<p>The spectrum plot shows the emission level in dBuV/m across a frequency range from 30 to 1000 MHz. A red line indicates the FCC CLASS-B limit, which is 40 dBuV/m for frequencies up to 30 MHz, 43.5 dBuV/m for 30-150 MHz, 46 dBuV/m for 150-1000 MHz, and 5 dB higher than the limit for frequencies above 900 MHz. Six peaks are identified and numbered 1 through 6, corresponding to the data in the table below.</p>											
	Freq	Level	Limit	Over	Read	CableAntenna	Preamp	A/Pos	T/Pos	Remark	Pol/Phase
	MHz	dBuV/m	dBuV/m	dB	dBuV	dB	dB/m	dB	cm	deg	
1	71.71	36.74	40.00	-3.26	55.96	0.86	12.06	32.14	300	278 Peak	HORIZONTAL
2	156.10	32.95	43.50	-10.55	47.67	1.28	16.13	32.13	200	164 Peak	HORIZONTAL
3	579.02	37.23	46.00	-8.77	42.56	2.55	24.13	32.01	150	179 Peak	HORIZONTAL
4	624.61	42.89	46.00	-3.11	47.08	2.66	25.21	32.06	150	144 Peak	HORIZONTAL
5	759.44	42.06	46.00	-3.94	45.45	2.95	25.66	32.00	125	49 Peak	HORIZONTAL
6	886.51	39.68	46.00	-6.32	41.52	3.09	26.40	31.33	100	176 Peak	HORIZONTAL

Note 1: ">20dB" means emission levels that exceed the level of 20 dB below the applicable limit.
 Note 2: "N/F" means Nothing Found emissions (No emissions were detected.)



Summary

Mode	Result	Type	Freq (Hz)	Level (dBuV/m)	Limit (dBuV/m)	Margin (dB)	Factor (dB)	Dist (m)	Condition	Azimuth (°)	Height (m)	Comments
5.15-5.25GHz	-	-	-	-	-	-	-	-	-	-	-	-
802.11ac VHT20_Nss1,(MCS0)_3TX	Pass	PK	5.1474G	73.63	74.00	-0.37	7.94	3	Horizontal	326	1.32	-

802.11a_Nss1,(6Mbps)_3TX

31/10/2019

5180MHz_TX

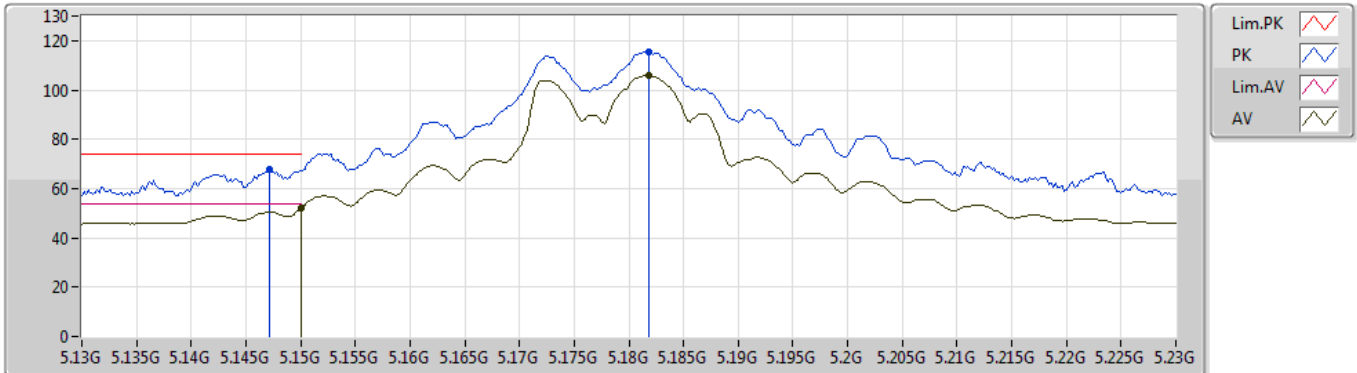

EUT Y_3TX
 Setting 20.5
 02-E-2-10
 FSU(100015)

Type	Freq (Hz)	Level (dBuV/m)	Limit (dBuV/m)	Margin (dB)	Factor (dB)	Dist (m)	Condition	Azimuth (°)	Height (m)	Comment	Raw (dBuV)
PK	5.1472G	67.70	74.00	-6.30	7.94	3	Vertical	64	1.19	-	59.76
AV	5.15G	51.99	54.00	-2.01	7.94	3	Vertical	64	1.19	-	44.05
PK	5.1818G	115.53	Inf	-Inf	8.02	3	Vertical	64	1.19	-	107.51
AV	5.1818G	105.81	Inf	-Inf	8.02	3	Vertical	64	1.19	-	97.79

802.11a_Nss1,(6Mbps)_3TX

31/10/2019

5180MHz_TX

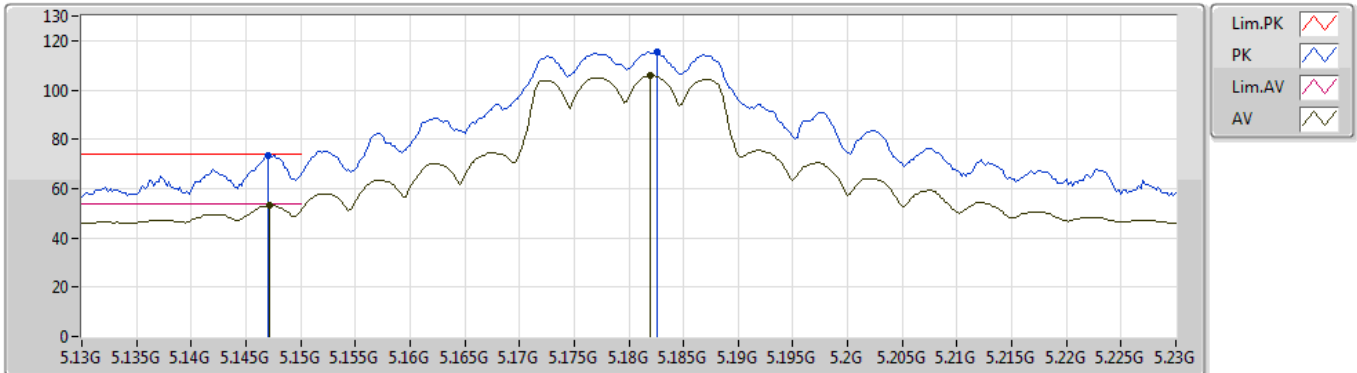

EUT Y_3TX
Setting 20.5
02-E-2-10
FSU(100015)

Type	Freq (Hz)	Level (dBuV/m)	Limit (dBuV/m)	Margin (dB)	Factor (dB)	Dist (m)	Condition	Azimuth (°)	Height (m)	Comment	Raw (dBuV)
PK	5.147G	73.57	74.00	-0.43	7.94	3	Horizontal	335	1.49	-	65.63
AV	5.147G	53.19	54.00	-0.81	7.94	3	Horizontal	335	1.49	-	45.25
PK	5.182G	115.47	Inf	-Inf	8.02	3	Horizontal	335	1.49	-	107.45
AV	5.182G	105.90	Inf	-Inf	8.02	3	Horizontal	335	1.49	-	97.88

802.11a_Nss1,(6Mbps)_3TX

31/10/2019

5180MHz_TX

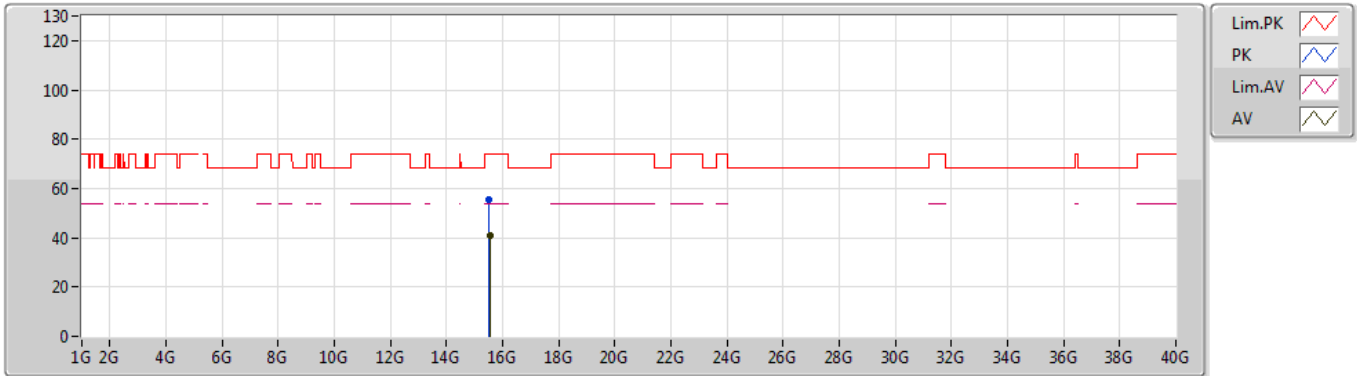

EUT Y_3TX
Setting 20.5
02-E-2
FSU(100015)

Type	Freq (Hz)	Level (dBuV/m)	Limit (dBuV/m)	Margin (dB)	Factor (dB)	Dist (m)	Condition	Azimuth (°)	Height (m)	Comment	Raw (dBuV)
PK	15.53196G	55.26	74.00	-18.74	16.10	3	Vertical	250	2.73	-	39.16
AV	15.53424G	41.18	54.00	-12.82	16.09	3	Vertical	250	2.73	-	25.09

802.11a_Nss1,(6Mbps)_3TX

31/10/2019

5180MHz_TX

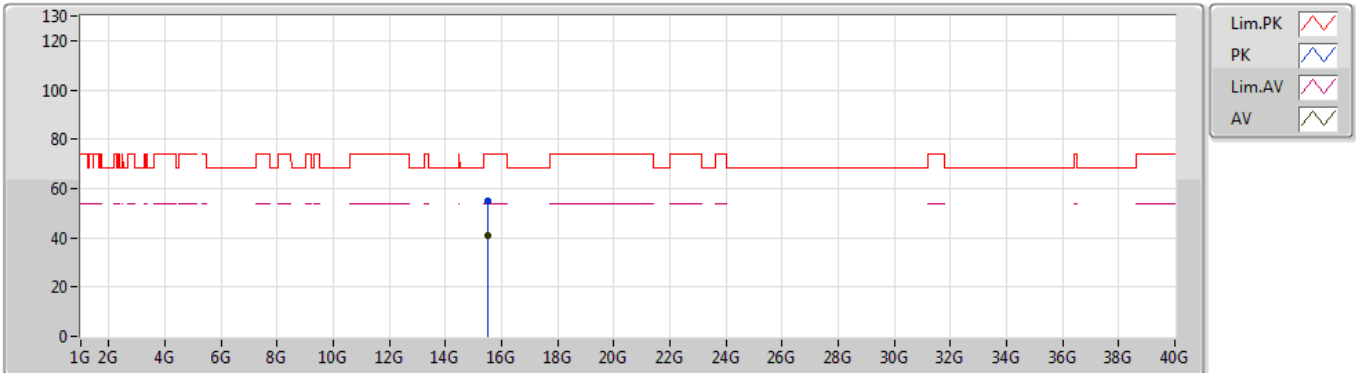

EUT Y_3TX
 Setting 20.5
 02-E-2
 FSU(100015)

Type	Freq (Hz)	Level (dBuV/m)	Limit (dBuV/m)	Margin (dB)	Factor (dB)	Dist (m)	Condition	Azimuth (°)	Height (m)	Comment	Raw (dBuV)
PK	15.52836G	55.05	74.00	-18.95	16.10	3	Horizontal	151	1.28	-	38.95
AV	15.53028G	40.98	54.00	-13.02	16.09	3	Horizontal	151	1.28	-	24.89

802.11a_Nss1,(6Mbps)_3TX

31/10/2019

5200MHz_TX

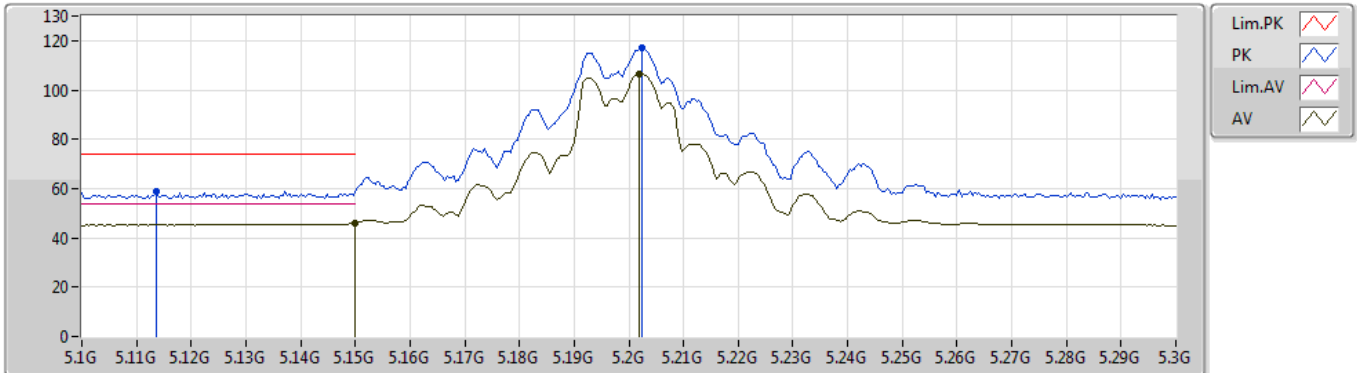

EUT Y_3TX
Setting 31.5
02-E-2-10
FSU(100015)

Type	Freq (Hz)	Level (dBuV/m)	Limit (dBuV/m)	Margin (dB)	Factor (dB)	Dist (m)	Condition	Azimuth (°)	Height (m)	Comment	Raw (dBuV)
PK	5.1136G	58.79	74.00	-15.21	7.86	3	Vertical	33	1.63	-	50.93
AV	5.15G	46.22	54.00	-7.78	7.94	3	Vertical	33	1.63	-	38.28
PK	5.2024G	116.87	Inf	-Inf	8.06	3	Vertical	33	1.63	-	108.81
AV	5.202G	106.47	Inf	-Inf	8.06	3	Vertical	33	1.63	-	98.41

802.11a_Nss1,(6Mbps)_3TX

31/10/2019

5200MHz_TX

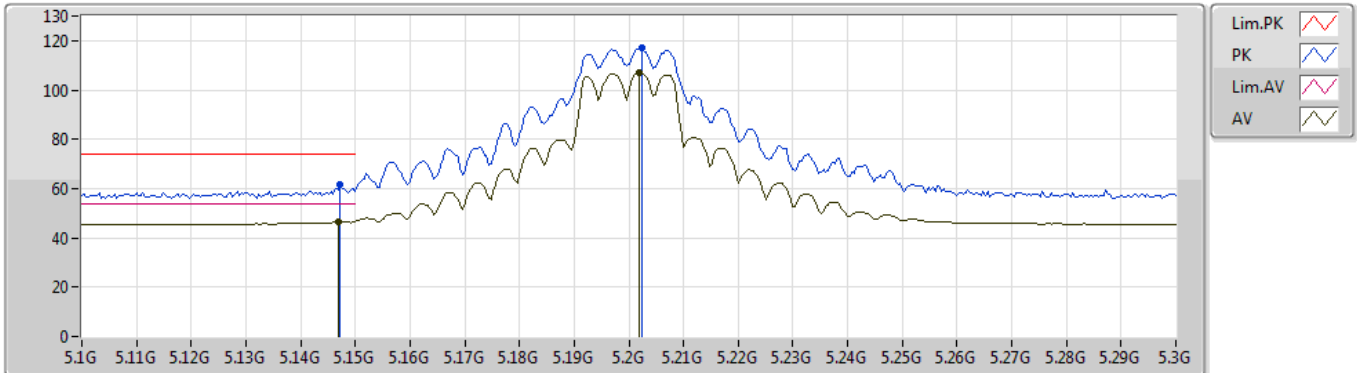

EUT Y_3TX
Setting 31.5
02-E-2-10
FSU(100015)

Type	Freq (Hz)	Level (dBuV/m)	Limit (dBuV/m)	Margin (dB)	Factor (dB)	Dist (m)	Condition	Azimuth (°)	Height (m)	Comment	Raw (dBuV)
PK	5.1472G	61.52	74.00	-12.48	7.94	3	Horizontal	317	1.50	-	53.58
AV	5.1468G	46.73	54.00	-7.27	7.94	3	Horizontal	317	1.50	-	38.79
PK	5.2024G	116.88	Inf	-Inf	8.06	3	Horizontal	317	1.50	-	108.82
AV	5.202G	106.88	Inf	-Inf	8.06	3	Horizontal	317	1.50	-	98.82

802.11a_Nss1,(6Mbps)_3TX

31/10/2019

5200MHz_TX

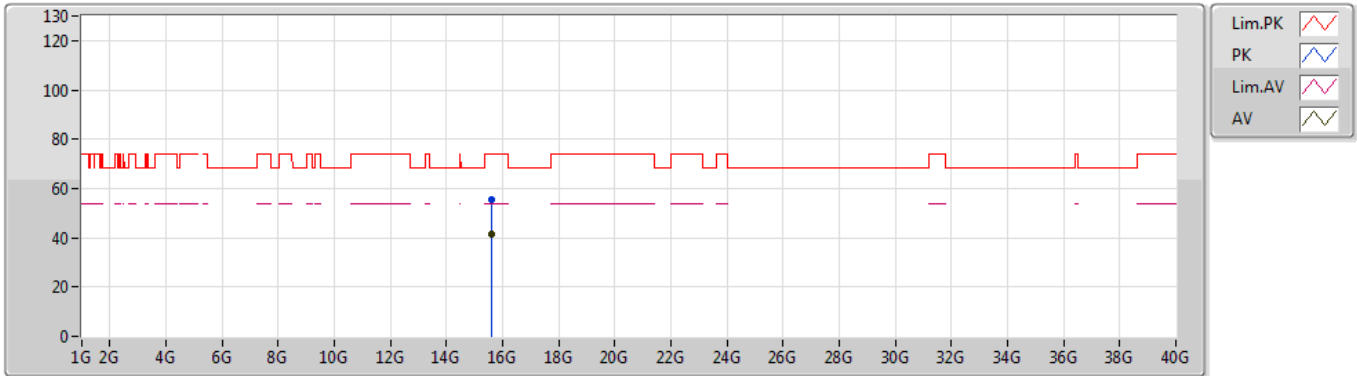

EUT Y_3TX
 Setting 31.5
 02-E-2
 FSU(100015)

Type	Freq (Hz)	Level (dBuV/m)	Limit (dBuV/m)	Margin (dB)	Factor (dB)	Dist (m)	Condition	Azimuth (°)	Height (m)	Comment	Raw (dBuV)
PK	15.60666G	55.21	74.00	-18.79	15.89	3	Vertical	253	2.40	-	39.32
AV	15.59646G	41.33	54.00	-12.67	15.92	3	Vertical	253	2.40	-	25.41

802.11a_Nss1,(6Mbps)_3TX

31/10/2019

5200MHz_TX

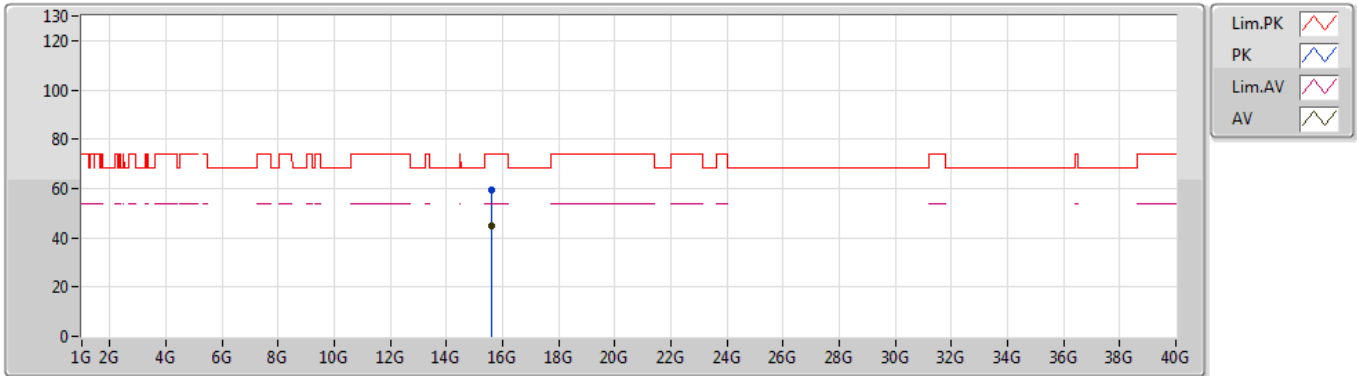

EUT Y_3TX
 Setting 31.5
 02-E-2
 FSU(100015)

Type	Freq (Hz)	Level (dBuV/m)	Limit (dBuV/m)	Margin (dB)	Factor (dB)	Dist (m)	Condition	Azimuth (°)	Height (m)	Comment	Raw (dBuV)
PK	15.6075G	59.67	74.00	-14.33	15.89	3	Horizontal	2	2.84	-	43.78
AV	15.5973G	45.03	54.00	-8.97	15.92	3	Horizontal	2	2.84	-	29.11

802.11a_Nss1,(6Mbps)_3TX

31/10/2019

5240MHz_TX

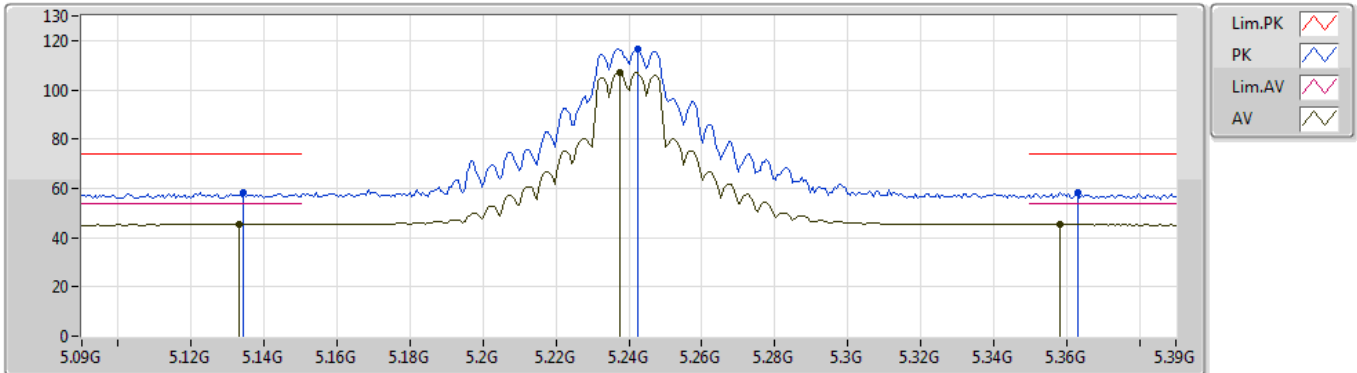

EUT_Y_3TX
Setting 31.5
02-E-2-10
FSU(100015)

Type	Freq (Hz)	Level (dBuV/m)	Limit (dBuV/m)	Margin (dB)	Factor (dB)	Dist (m)	Condition	Azimuth (°)	Height (m)	Comment	Raw (dBuV)
PK	5.1344G	58.34	74.00	-15.66	7.92	3	Vertical	336	1.26	-	50.42
AV	5.1332G	45.40	54.00	-8.60	7.92	3	Vertical	336	1.26	-	37.48
PK	5.2424G	116.57	Inf	-Inf	8.12	3	Vertical	336	1.26	-	108.45
AV	5.2376G	106.82	Inf	-Inf	8.12	3	Vertical	336	1.26	-	98.70
PK	5.363G	58.22	74.00	-15.78	8.29	3	Vertical	336	1.26	-	49.93
AV	5.3582G	45.26	54.00	-8.74	8.28	3	Vertical	336	1.26	-	36.98

802.11a_Nss1,(6Mbps)_3TX

31/10/2019

5240MHz_TX

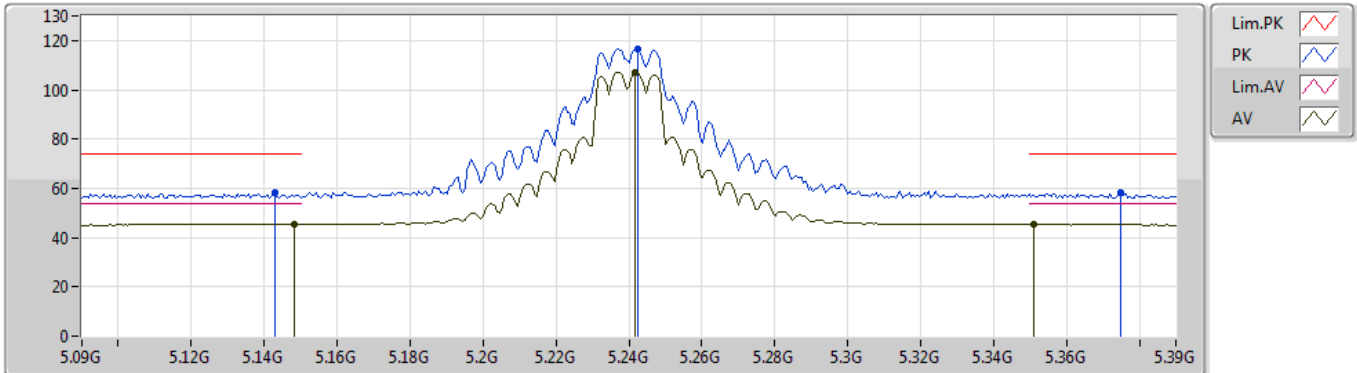

EUT_Y_3TX
Setting 31.5
02-E-2-10
FSU(100015)

Type	Freq (Hz)	Level (dBuV/m)	Limit (dBuV/m)	Margin (dB)	Factor (dB)	Dist (m)	Condition	Azimuth (°)	Height (m)	Comment	Raw (dBuV)
PK	5.1428G	58.13	74.00	-15.87	7.94	3	Horizontal	330	1.39	-	50.19
AV	5.1482G	45.48	54.00	-8.52	7.94	3	Horizontal	330	1.39	-	37.54
PK	5.2424G	116.65	Inf	-Inf	8.12	3	Horizontal	330	1.39	-	108.53
AV	5.2418G	107.25	Inf	-Inf	8.12	3	Horizontal	330	1.39	-	99.13
PK	5.375G	58.33	74.00	-15.67	8.31	3	Horizontal	330	1.39	-	50.02
AV	5.351G	45.31	54.00	-8.69	8.28	3	Horizontal	330	1.39	-	37.03

802.11a_Nss1,(6Mbps)_3TX

31/10/2019

5240MHz_TX

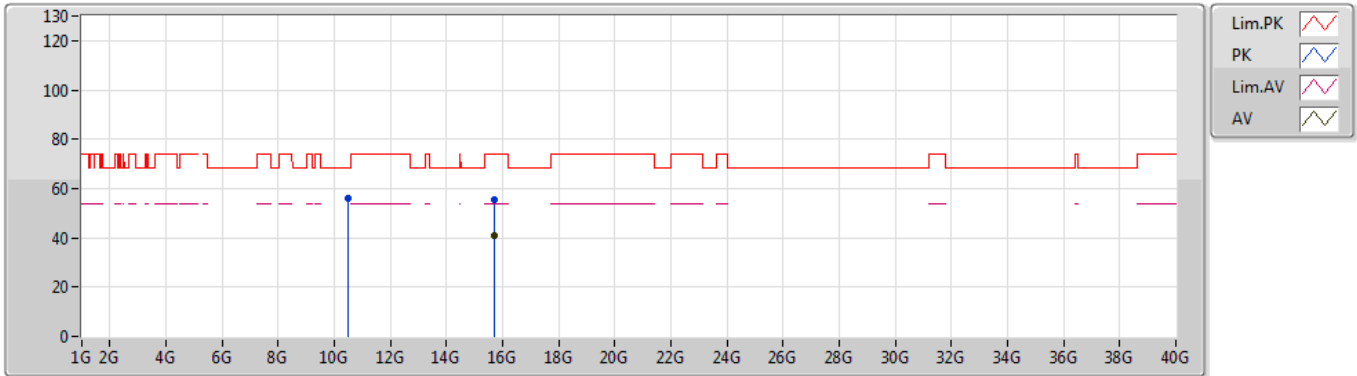

EUT Y_3TX
Setting 31.5
02-E-2
FSU(100015)

Type	Freq (Hz)	Level (dBuV/m)	Limit (dBuV/m)	Margin (dB)	Factor (dB)	Dist (m)	Condition	Azimuth (°)	Height (m)	Comment	Raw (dBuV)
PK	10.47985G	56.17	68.20	-12.03	14.58	3	Vertical	360	1.50	-	41.59
PK	15.70578G	55.50	74.00	-18.50	15.63	3	Vertical	275	2.97	-	39.87
AV	15.72306G	40.79	54.00	-13.21	15.59	3	Vertical	275	2.97	-	25.20

802.11a_Nss1,(6Mbps)_3TX

31/10/2019

5240MHz_TX

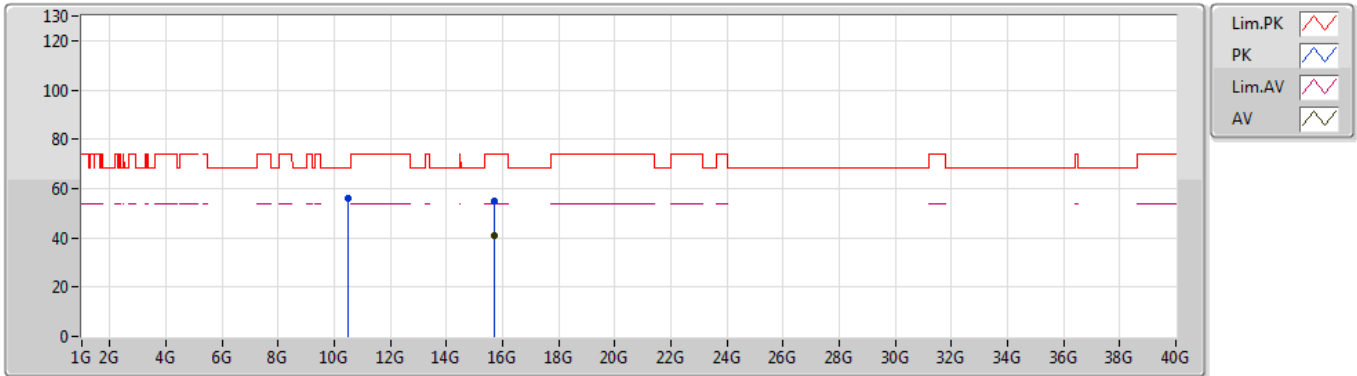

EUT Y_3TX
Setting 31.5
02-E-2
FSU(100015)

Type	Freq (Hz)	Level (dBuV/m)	Limit (dBuV/m)	Margin (dB)	Factor (dB)	Dist (m)	Condition	Azimuth (°)	Height (m)	Comment	Raw (dBuV)
PK	10.48006G	55.82	68.20	-12.38	14.58	3	Horizontal	6	1.39	-	41.24
PK	15.7221G	54.90	74.00	-19.10	15.60	3	Horizontal	34	1.50	-	39.30
AV	15.71874G	41.04	54.00	-12.96	15.61	3	Horizontal	34	1.50	-	25.43

802.11a_Nss1,(6Mbps)_3TX

31/10/2019

5745MHz_TX

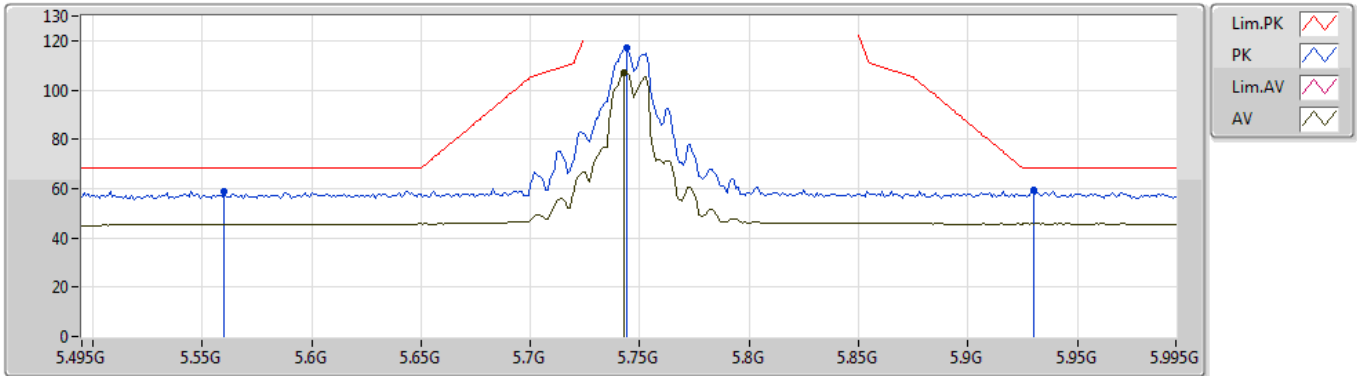

EUT_Y_3TX
Setting 31.5
02-E-2-10
FSU(100015)

Type	Freq (Hz)	Level (dBuV/m)	Limit (dBuV/m)	Margin (dB)	Factor (dB)	Dist (m)	Condition	Azimuth (°)	Height (m)	Comment	Raw (dBuV)
PK	5.56G	59.01	68.20	-9.19	8.56	3	Vertical	78	2.51	-	50.45
PK	5.744G	117.31	Inf	-Inf	8.82	3	Vertical	78	2.51	-	108.49
AV	5.743G	107.29	Inf	-Inf	8.82	3	Vertical	78	2.51	-	98.47
PK	5.93G	59.66	68.20	-8.54	8.93	3	Vertical	78	2.51	-	50.73

802.11a_Nss1,(6Mbps)_3TX

31/10/2019

5745MHz_TX

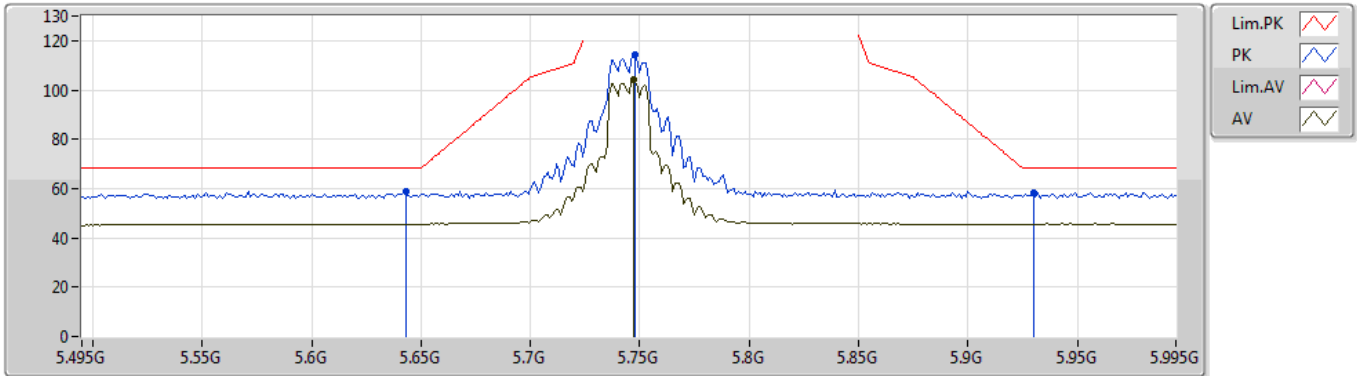

EUT Y_3TX
Setting 31.5
02-E-2-10
FSU(100015)

Type	Freq (Hz)	Level (dBuV/m)	Limit (dBuV/m)	Margin (dB)	Factor (dB)	Dist (m)	Condition	Azimuth (°)	Height (m)	Comment	Raw (dBuV)
PK	5.643G	58.86	68.20	-9.34	8.66	3	Horizontal	331	2.87	-	50.20
PK	5.748G	114.49	Inf	-Inf	8.82	3	Horizontal	331	2.87	-	105.67
AV	5.747G	104.07	Inf	-Inf	8.82	3	Horizontal	331	2.87	-	95.25
PK	5.939G	58.30	68.20	-9.90	8.93	3	Horizontal	331	2.87	-	49.37

802.11a_Nss1,(6Mbps)_3TX

31/10/2019

5745MHz_TX

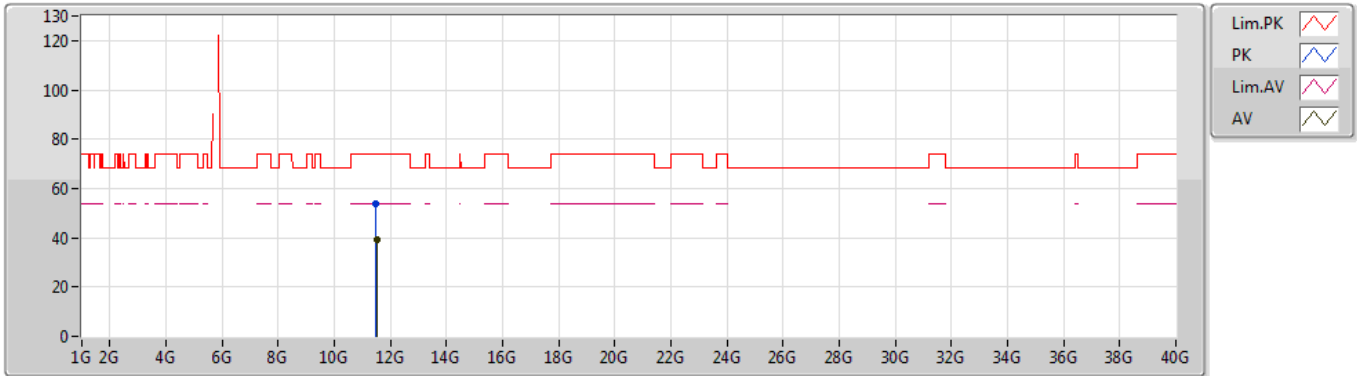

EUT Y_3TX
Setting 31.5
02-E-2
FSU(100015)

Type	Freq (Hz)	Level (dBuV/m)	Limit (dBuV/m)	Margin (dB)	Factor (dB)	Dist (m)	Condition	Azimuth (°)	Height (m)	Comment	Raw (dBuV)
PK	11.48544G	53.62	74.00	-20.38	14.89	3	Vertical	144	1.10	-	38.73
AV	11.50476G	39.41	54.00	-14.59	14.91	3	Vertical	144	1.10	-	24.50

802.11a_Nss1,(6Mbps)_3TX

31/10/2019

5745MHz_TX

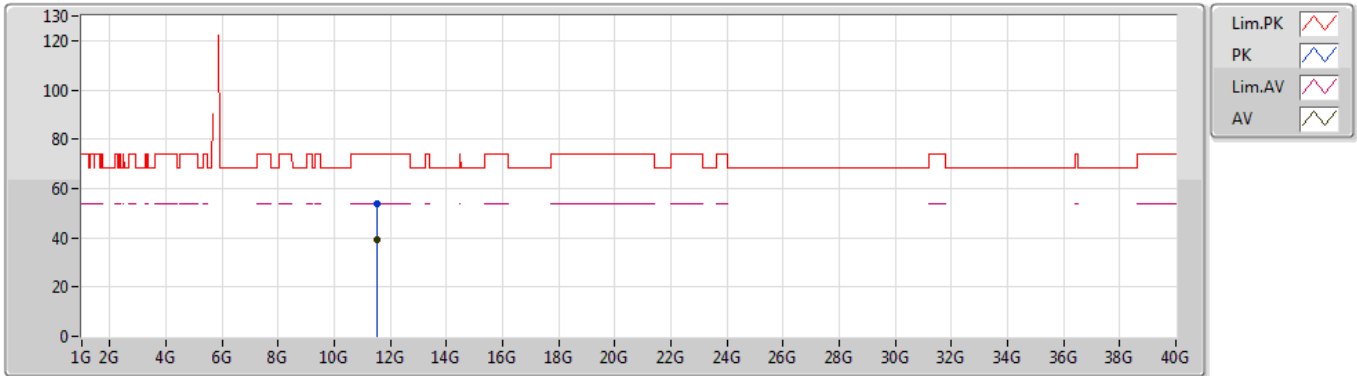

EUT Y_3TX
Setting 31.5
02-E-2
FSU(100015)

Type	Freq (Hz)	Level (dBuV/m)	Limit (dBuV/m)	Margin (dB)	Factor (dB)	Dist (m)	Condition	Azimuth (°)	Height (m)	Comment	Raw (dBuV)
PK	11.50272G	53.83	74.00	-20.17	14.91	3	Horizontal	48	2.99	-	38.92
AV	11.50278G	39.42	54.00	-14.58	14.91	3	Horizontal	48	2.99	-	24.51

802.11a_Nss1,(6Mbps)_3TX

31/10/2019

5785MHz_TX

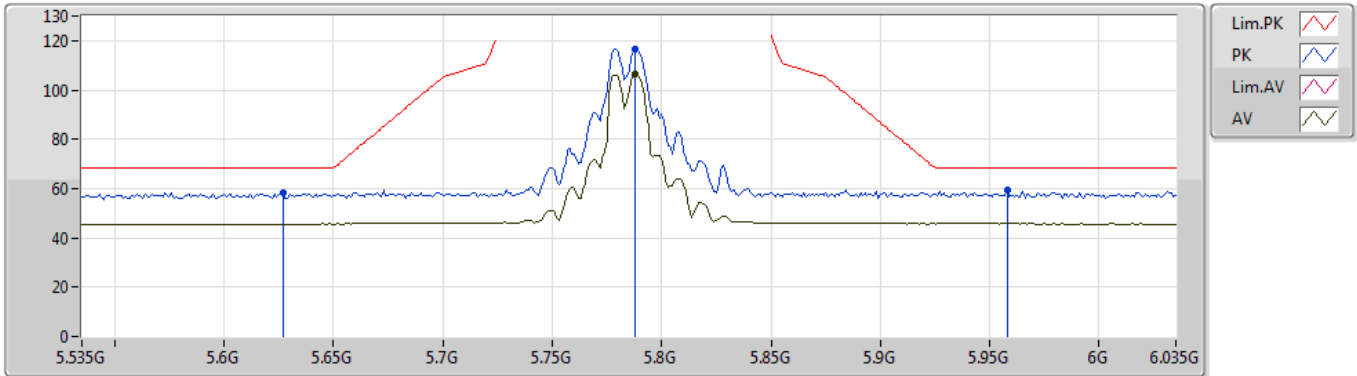

EUT Y_3TX
Setting 31.5
02-E-2-10
FSU(100015)

Type	Freq (Hz)	Level (dBuV/m)	Limit (dBuV/m)	Margin (dB)	Factor (dB)	Dist (m)	Condition	Azimuth (°)	Height (m)	Comment	Raw (dBuV)
PK	5.627G	58.24	68.20	-9.96	8.63	3	Vertical	81	1.56	-	49.61
PK	5.788G	116.70	Inf	-Inf	8.87	3	Vertical	81	1.56	-	107.83
AV	5.788G	106.61	Inf	-Inf	8.87	3	Vertical	81	1.56	-	97.74
PK	5.958G	59.18	68.20	-9.02	8.92	3	Vertical	81	1.56	-	50.26

802.11a_Nss1,(6Mbps)_3TX

31/10/2019

5785MHz_TX

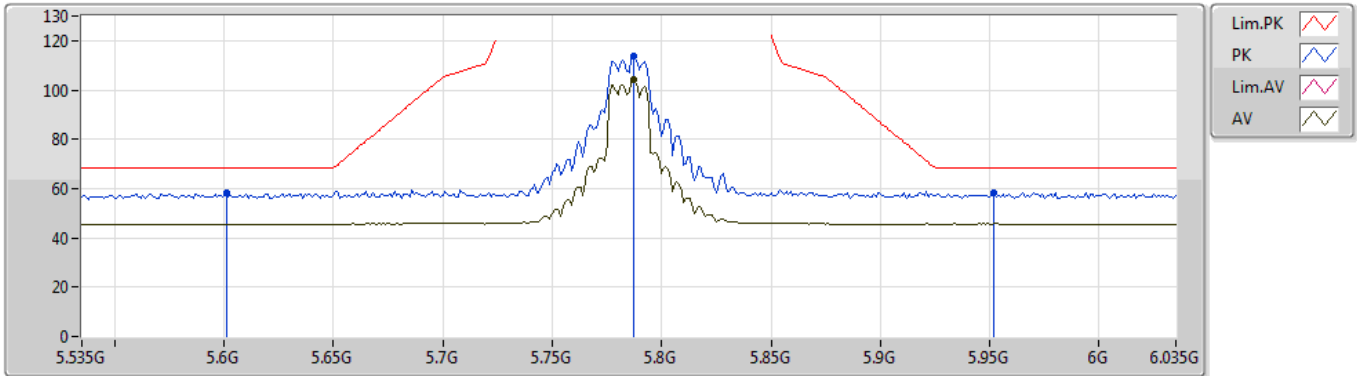

EUT Y_3TX
Setting 31.5
02-E-2-10
FSU(100015)

Type	Freq (Hz)	Level (dBuV/m)	Limit (dBuV/m)	Margin (dB)	Factor (dB)	Dist (m)	Condition	Azimuth (°)	Height (m)	Comment	Raw (dBuV)
PK	5.601G	58.22	68.20	-9.98	8.58	3	Horizontal	329	2.81	-	49.64
PK	5.787G	114.00	Inf	-Inf	8.88	3	Horizontal	329	2.81	-	105.12
AV	5.787G	103.99	Inf	-Inf	8.88	3	Horizontal	329	2.81	-	95.11
PK	5.952G	58.23	68.20	-9.97	8.92	3	Horizontal	329	2.81	-	49.31

802.11a_Nss1,(6Mbps)_3TX

31/10/2019

5785MHz_TX

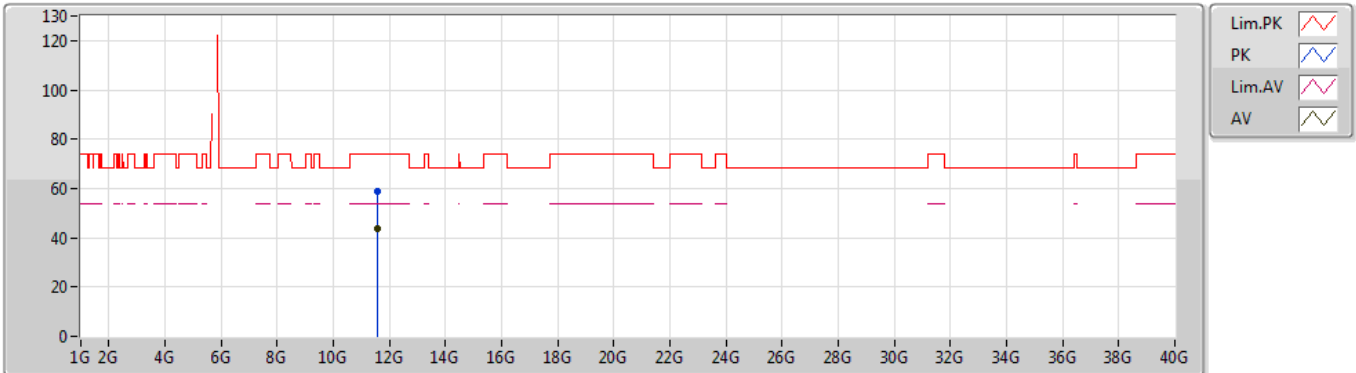

EUT Y_3TX
 Setting 31.5
 02-E-2
 FSU(100015)

Type	Freq (Hz)	Level (dBuV/m)	Limit (dBuV/m)	Margin (dB)	Factor (dB)	Dist (m)	Condition	Azimuth (°)	Height (m)	Comment	Raw (dBuV)
PK	11.56928G	58.72	74.00	-15.28	15.00	3	Vertical	193	1.50	-	43.72
AV	11.56988G	43.74	54.00	-10.26	15.00	3	Vertical	193	1.50	-	28.74

802.11a_Nss1,(6Mbps)_3TX

31/10/2019

5785MHz_TX

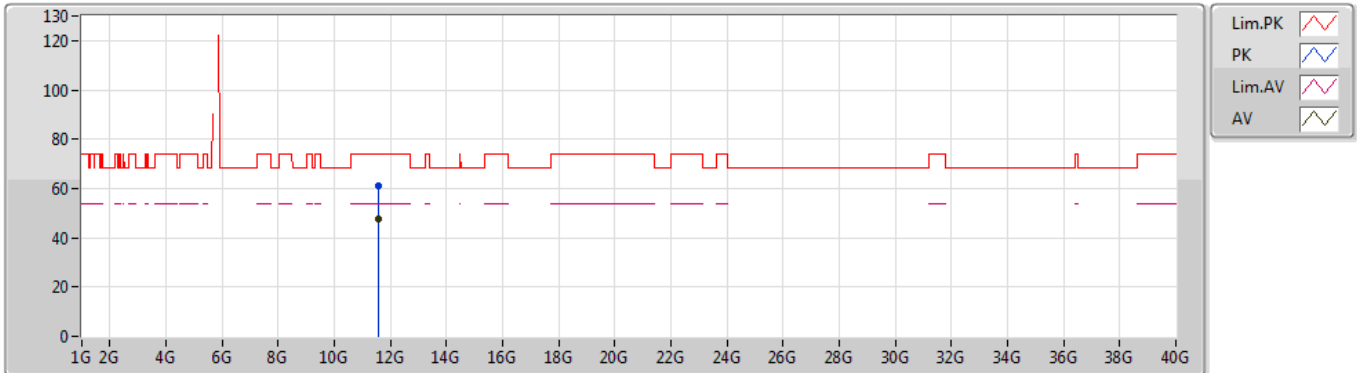

EUT Y_3TX
Setting 31.5
02-E-2
FSU(100015)

Type	Freq (Hz)	Level (dBuV/m)	Limit (dBuV/m)	Margin (dB)	Factor (dB)	Dist (m)	Condition	Azimuth (°)	Height (m)	Comment	Raw (dBuV)
PK	11.56772G	60.88	74.00	-13.12	14.99	3	Horizontal	302	1.35	-	45.89
AV	11.56748G	47.69	54.00	-6.31	14.99	3	Horizontal	302	1.35	-	32.70

802.11a_Nss1,(6Mbps)_3TX

31/10/2019

5825MHz_TX

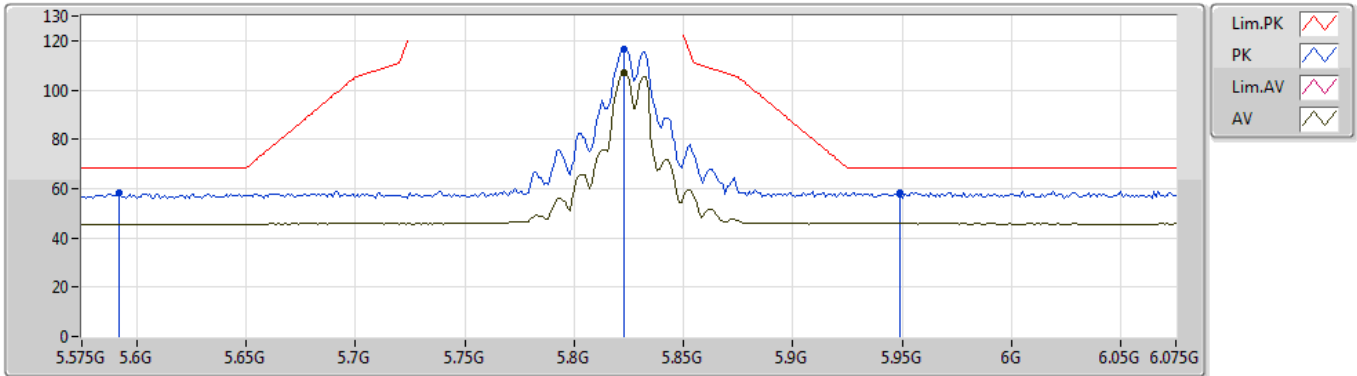

EUT Y_3TX
Setting 31.5
02-E-2-10
FSU(100015)

Type	Freq (Hz)	Level (dBuV/m)	Limit (dBuV/m)	Margin (dB)	Factor (dB)	Dist (m)	Condition	Azimuth (°)	Height (m)	Comment	Raw (dBuV)
PK	5.592G	58.00	68.20	-10.20	8.58	3	Vertical	83	2.19	-	49.42
PK	5.823G	116.67	Inf	-Inf	8.90	3	Vertical	83	2.19	-	107.77
AV	5.823G	106.84	Inf	-Inf	8.90	3	Vertical	83	2.19	-	97.94
PK	5.949G	58.39	68.20	-9.81	8.94	3	Vertical	83	2.19	-	49.45

802.11a_Nss1,(6Mbps)_3TX

31/10/2019

5825MHz_TX

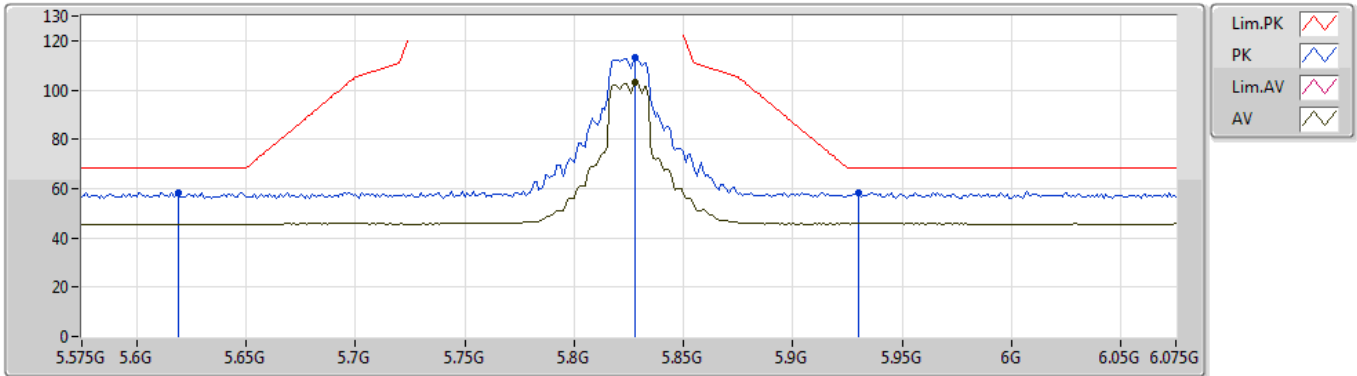

EUT_Y_3TX
Setting 31.5
02-E-2-10
FSU(100015)

Type	Freq (Hz)	Level (dBuV/m)	Limit (dBuV/m)	Margin (dB)	Factor (dB)	Dist (m)	Condition	Azimuth (°)	Height (m)	Comment	Raw (dBuV)
PK	5.619G	58.31	68.20	-9.89	8.61	3	Horizontal	349	2.80	-	49.70
PK	5.828G	113.20	Inf	-Inf	8.91	3	Horizontal	349	2.80	-	104.29
AV	5.828G	103.05	Inf	-Inf	8.91	3	Horizontal	349	2.80	-	94.14
PK	5.93G	58.51	68.20	-9.69	8.93	3	Horizontal	349	2.80	-	49.58

802.11a_Nss1,(6Mbps)_3TX

31/10/2019

5825MHz_TX

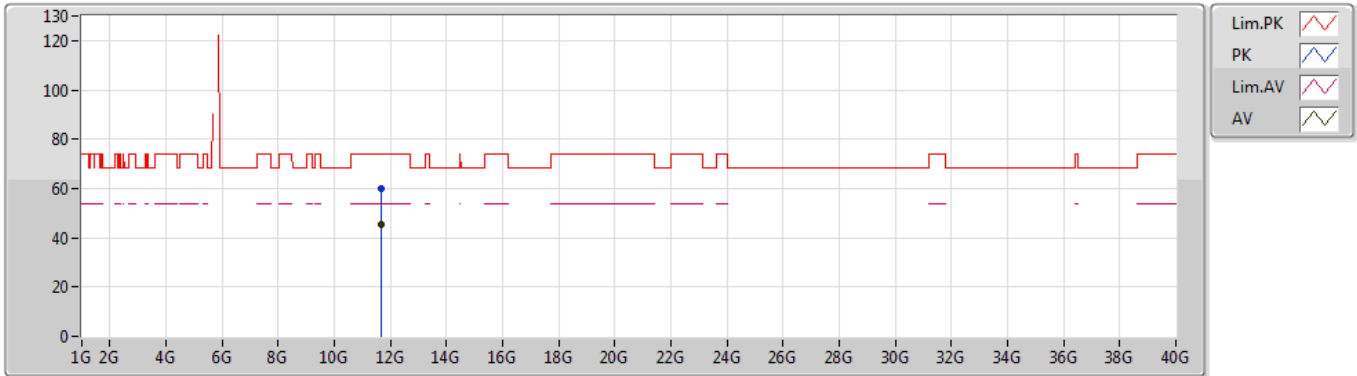

EUT Y_3TX
Setting 31.5
02-E-2
FSU(100015)

Type	Freq (Hz)	Level (dBuV/m)	Limit (dBuV/m)	Margin (dB)	Factor (dB)	Dist (m)	Condition	Azimuth (°)	Height (m)	Comment	Raw (dBuV)
PK	11.65018G	59.78	74.00	-14.22	15.09	3	Vertical	230	1.88	-	44.69
AV	11.65006G	45.14	54.00	-8.86	15.09	3	Vertical	230	1.88	-	30.05

802.11a_Nss1,(6Mbps)_3TX

31/10/2019

5825MHz_TX

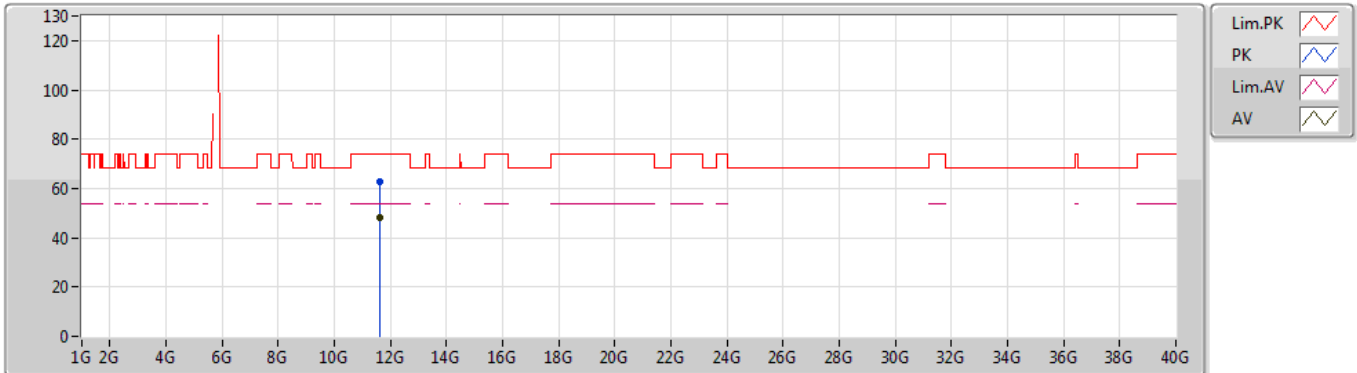

EUT Y_3TX
Setting 31.5
02-E-2
FSU(100015)

Type	Freq (Hz)	Level (dBuV/m)	Limit (dBuV/m)	Margin (dB)	Factor (dB)	Dist (m)	Condition	Azimuth (°)	Height (m)	Comment	Raw (dBuV)
PK	11.64622G	62.63	74.00	-11.37	15.09	3	Horizontal	301	1.35	-	47.54
AV	11.64742G	48.20	54.00	-5.80	15.09	3	Horizontal	301	1.35	-	33.11

802.11ac VHT20_Nss1,(MCS0)_3TX

31/10/2019

5180MHz_TX

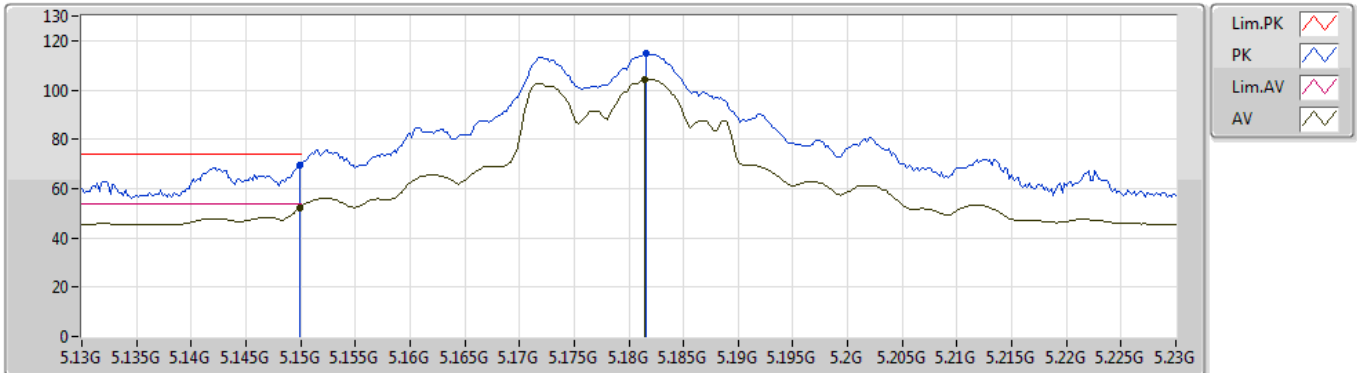

EUT Y_3TX
Setting 20
02-E-2-10
FSU(100015)

Type	Freq (Hz)	Level (dBuV/m)	Limit (dBuV/m)	Margin (dB)	Factor (dB)	Dist (m)	Condition	Azimuth (°)	Height (m)	Comment	Raw (dBuV)
PK	5.1499G	69.66	74.00	-4.34	7.94	3	Vertical	67	1.29	-	61.72
AV	5.1499G	52.26	54.00	-1.74	7.94	3	Vertical	67	1.29	-	44.32
PK	5.1816G	115.13	Inf	-Inf	8.02	3	Vertical	67	1.29	-	107.11
AV	5.1814G	104.35	Inf	-Inf	8.02	3	Vertical	67	1.29	-	96.33

802.11ac VHT20_Nss1,(MCS0)_3TX

31/10/2019

5180MHz_TX

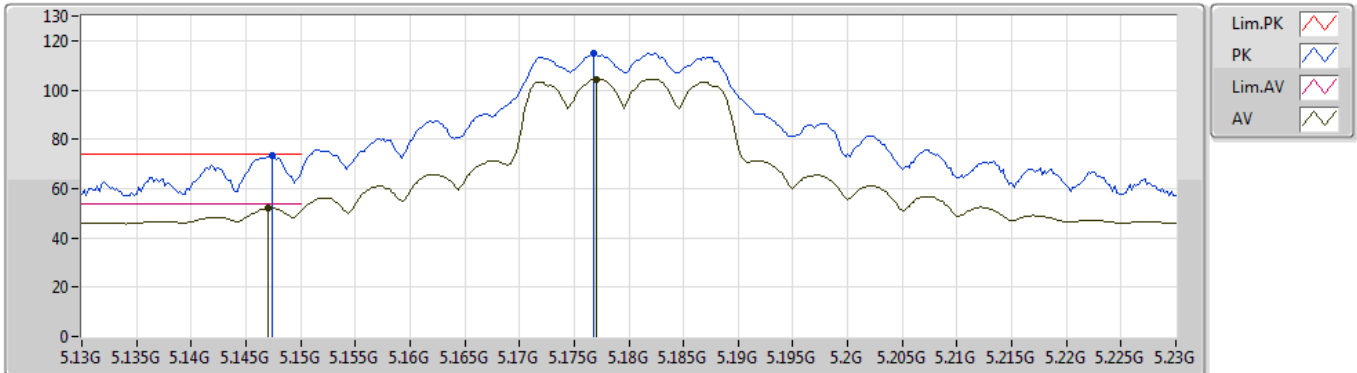

EUT Y_3TX
Setting 20
02-E-2-10
FSU(100015)

Type	Freq (Hz)	Level (dBuV/m)	Limit (dBuV/m)	Margin (dB)	Factor (dB)	Dist (m)	Condition	Azimuth (°)	Height (m)	Comment	Raw (dBuV)
PK	5.1474G	73.63	74.00	-0.37	7.94	3	Horizontal	326	1.32	-	65.69
AV	5.147G	51.99	54.00	-2.01	7.94	3	Horizontal	326	1.32	-	44.05
PK	5.1768G	114.82	Inf	-Inf	8.01	3	Horizontal	326	1.32	-	106.81
AV	5.177G	104.45	Inf	-Inf	8.01	3	Horizontal	326	1.32	-	96.44

802.11ac VHT20_Nss1,(MCS0)_3TX

31/10/2019

5180MHz_TX

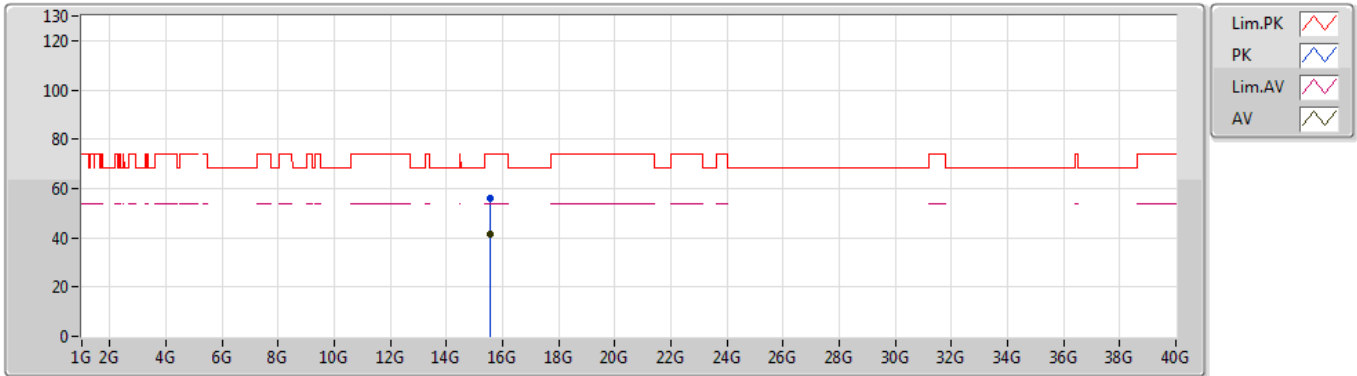

EUT Y_3TX
Setting 20
02-E-2
FSU(100015)

Type	Freq (Hz)	Level (dBuV/m)	Limit (dBuV/m)	Margin (dB)	Factor (dB)	Dist (m)	Condition	Azimuth (°)	Height (m)	Comment	Raw (dBuV)
PK	15.5523G	55.87	74.00	-18.13	16.04	3	Vertical	289	2.81	-	39.83
AV	15.54114G	41.21	54.00	-12.79	16.07	3	Vertical	289	2.81	-	25.14

802.11ac VHT20_Nss1,(MCS0)_3TX

31/10/2019

5180MHz_TX

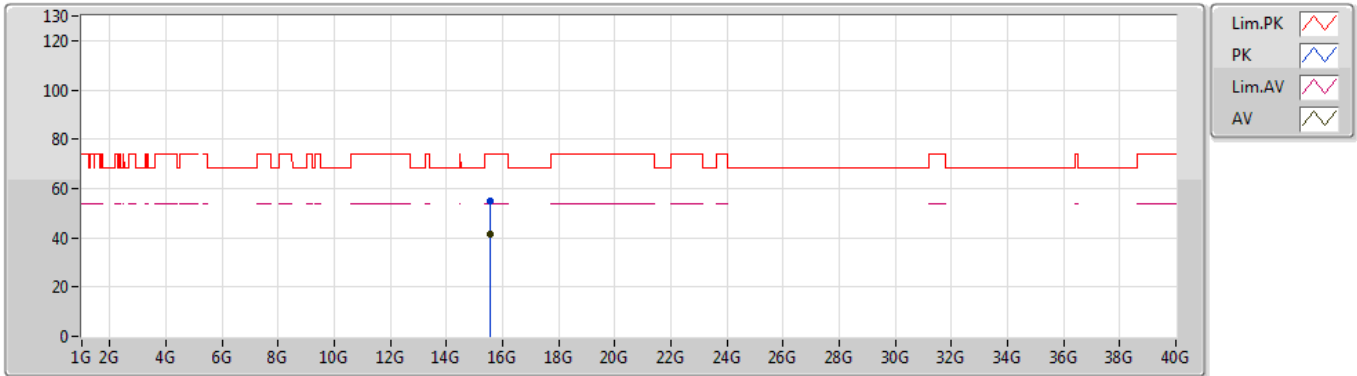

EUT Y_3TX
Setting 20
02-E-2
FSU(100015)

Type	Freq (Hz)	Level (dBuV/m)	Limit (dBuV/m)	Margin (dB)	Factor (dB)	Dist (m)	Condition	Azimuth (°)	Height (m)	Comment	Raw (dBuV)
PK	15.53724G	55.04	74.00	-18.96	16.08	3	Horizontal	80	2.30	-	38.96
AV	15.5385G	41.62	54.00	-12.38	16.08	3	Horizontal	80	2.30	-	25.54

802.11ac VHT20_Nss1,(MCS0)_3TX

31/10/2019

5200MHz_TX

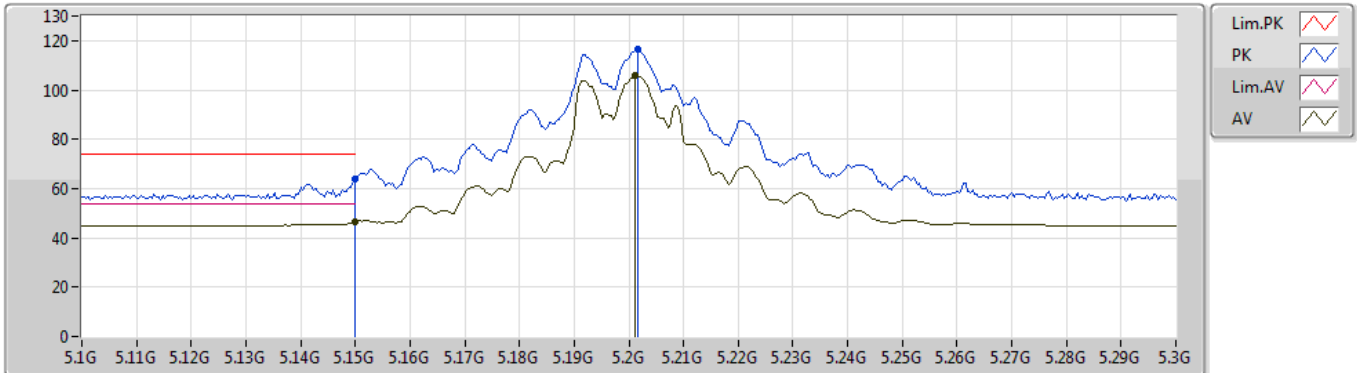

EUT Y_3TX
 Setting 31.5
 02-G-3-10
 FSU(100015)

Type	Freq (Hz)	Level (dBuV/m)	Limit (dBuV/m)	Margin (dB)	Factor (dB)	Dist (m)	Condition	Azimuth (°)	Height (m)	Comment	Raw (dBuV)
PK	5.15G	63.89	74.00	-10.11	7.94	3	Vertical	69	1.04	-	55.95
AV	5.15G	46.28	54.00	-7.72	7.94	3	Vertical	69	1.04	-	38.34
PK	5.2016G	116.50	Inf	-Inf	8.06	3	Vertical	69	1.04	-	108.44
AV	5.2012G	105.66	Inf	-Inf	8.06	3	Vertical	69	1.04	-	97.60

802.11ac VHT20_Nss1,(MCS0)_3TX

31/10/2019

5200MHz_TX

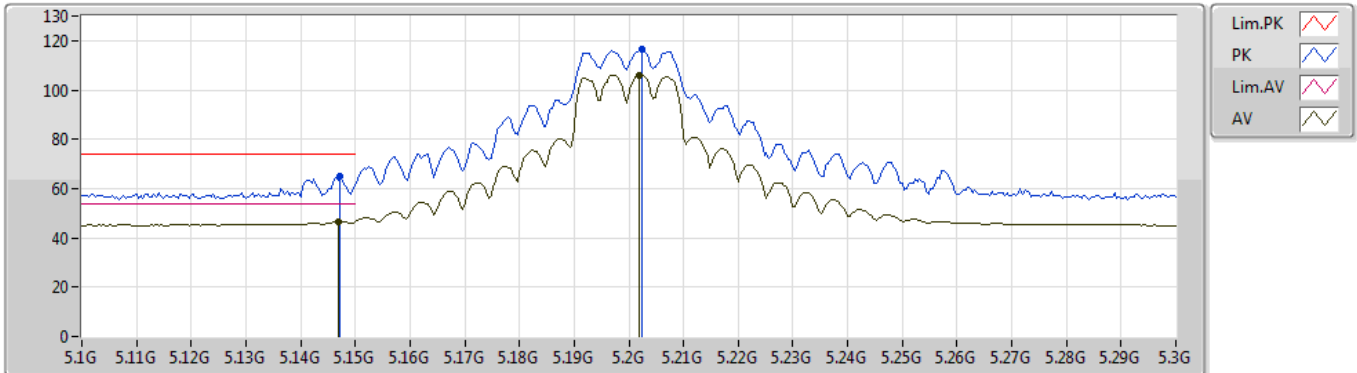

EUT Y_3TX
Setting 31.5
02-G-3-10
FSU(100015)

Type	Freq (Hz)	Level (dBuV/m)	Limit (dBuV/m)	Margin (dB)	Factor (dB)	Dist (m)	Condition	Azimuth (°)	Height (m)	Comment	Raw (dBuV)
PK	5.1472G	64.92	74.00	-9.08	7.94	3	Horizontal	329	1.52	-	56.98
AV	5.1468G	46.60	54.00	-7.40	7.94	3	Horizontal	329	1.52	-	38.66
PK	5.2024G	116.75	Inf	-Inf	8.06	3	Horizontal	329	1.52	-	108.69
AV	5.202G	106.16	Inf	-Inf	8.06	3	Horizontal	329	1.52	-	98.10

802.11ac VHT20_Nss1,(MCS0)_3TX

31/10/2019

5240MHz_TX

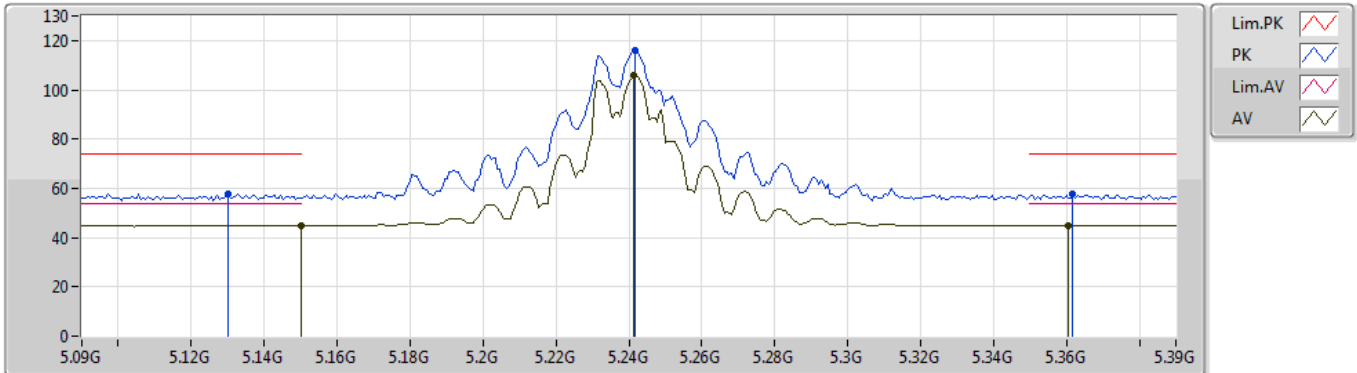

EUT_Y_3TX
Setting 31.5
02-G-3-10
FSU(100015)

Type	Freq (Hz)	Level (dBuV/m)	Limit (dBuV/m)	Margin (dB)	Factor (dB)	Dist (m)	Condition	Azimuth (°)	Height (m)	Comment	Raw (dBuV)
PK	5.1302G	57.89	74.00	-16.11	7.91	3	Vertical	65	1.20	-	49.98
AV	5.15G	44.83	54.00	-9.17	7.94	3	Vertical	65	1.20	-	36.89
PK	5.2418G	116.11	Inf	-Inf	8.12	3	Vertical	65	1.20	-	107.99
AV	5.2412G	105.78	Inf	-Inf	8.12	3	Vertical	65	1.20	-	97.66
PK	5.3618G	57.90	74.00	-16.10	8.29	3	Vertical	65	1.20	-	49.61
AV	5.3606G	44.87	54.00	-9.13	8.29	3	Vertical	65	1.20	-	36.58

802.11ac VHT20_Nss1,(MCS0)_3TX

31/10/2019

5240MHz_TX

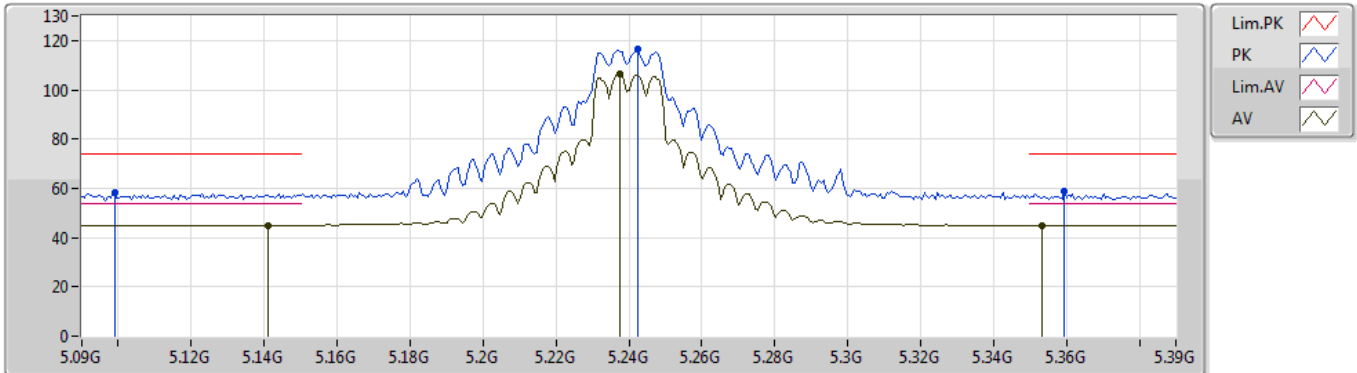

EUT Y_3TX
Setting 31.5
02-G-3-10
FSU(100015)

Type	Freq (Hz)	Level (dBuV/m)	Limit (dBuV/m)	Margin (dB)	Factor (dB)	Dist (m)	Condition	Azimuth (°)	Height (m)	Comment	Raw (dBuV)
PK	5.099G	58.14	74.00	-15.86	7.84	3	Horizontal	335	1.37	-	50.30
AV	5.141G	45.04	54.00	-8.96	7.94	3	Horizontal	335	1.37	-	37.10
PK	5.2424G	116.40	Inf	-Inf	8.12	3	Horizontal	335	1.37	-	108.28
AV	5.2376G	106.60	Inf	-Inf	8.12	3	Horizontal	335	1.37	-	98.48
PK	5.3594G	58.84	74.00	-15.16	8.29	3	Horizontal	335	1.37	-	50.55
AV	5.3534G	45.02	54.00	-8.98	8.28	3	Horizontal	335	1.37	-	36.74

802.11ac VHT20_Nss1,(MCS0)_3TX

31/10/2019

5240MHz_TX

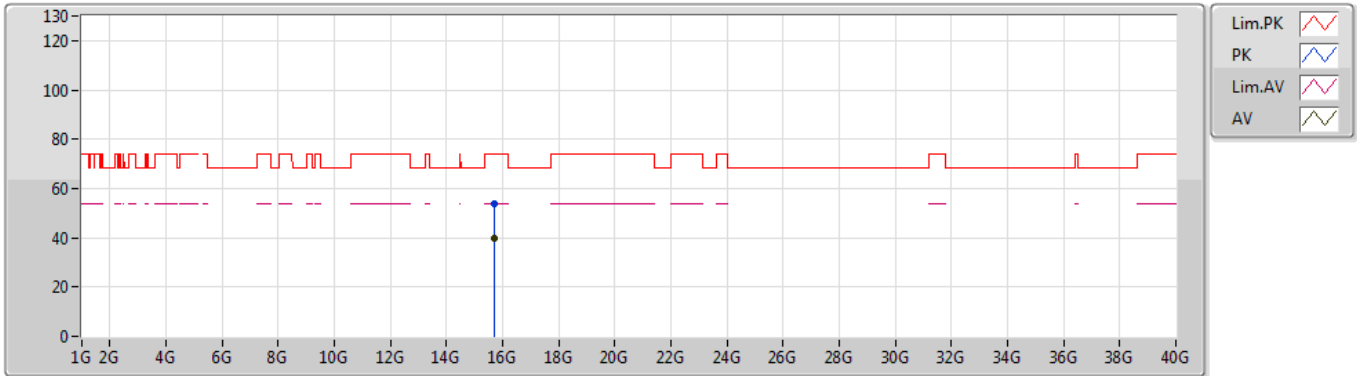

EUT Y_3TX
 Setting 31.5
 02-G-3
 FSU(100015)

Type	Freq (Hz)	Level (dBuV/m)	Limit (dBuV/m)	Margin (dB)	Factor (dB)	Dist (m)	Condition	Azimuth (°)	Height (m)	Comment	Raw (dBuV)
PK	15.71476G	54.00	74.00	-20.00	15.62	3	Vertical	90	1.46	-	38.38
AV	15.71596G	39.89	54.00	-14.11	15.61	3	Vertical	90	1.46	-	24.28

802.11ac VHT20_Nss1,(MCS0)_3TX

31/10/2019

5240MHz_TX

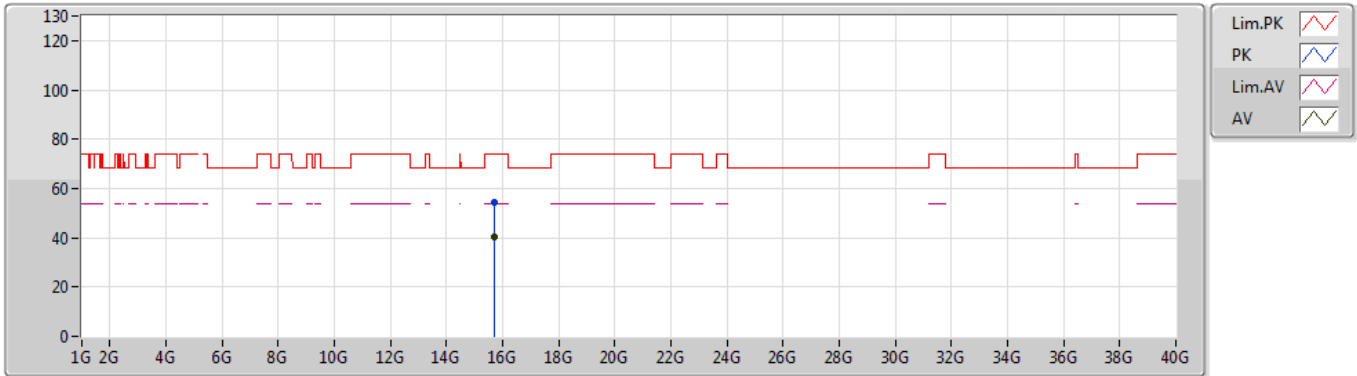

EUT Y_3TX
Setting 31.5
02-G-3
FSU(100015)

Type	Freq (Hz)	Level (dBuV/m)	Limit (dBuV/m)	Margin (dB)	Factor (dB)	Dist (m)	Condition	Azimuth (°)	Height (m)	Comment	Raw (dBuV)
PK	15.71844G	54.51	74.00	-19.49	15.61	3	Horizontal	149	1.45	-	38.90
AV	15.71868G	40.52	54.00	-13.48	15.61	3	Horizontal	149	1.45	-	24.91

802.11ac VHT20_Nss1,(MCS0)_3TX

31/10/2019

5745MHz_TX

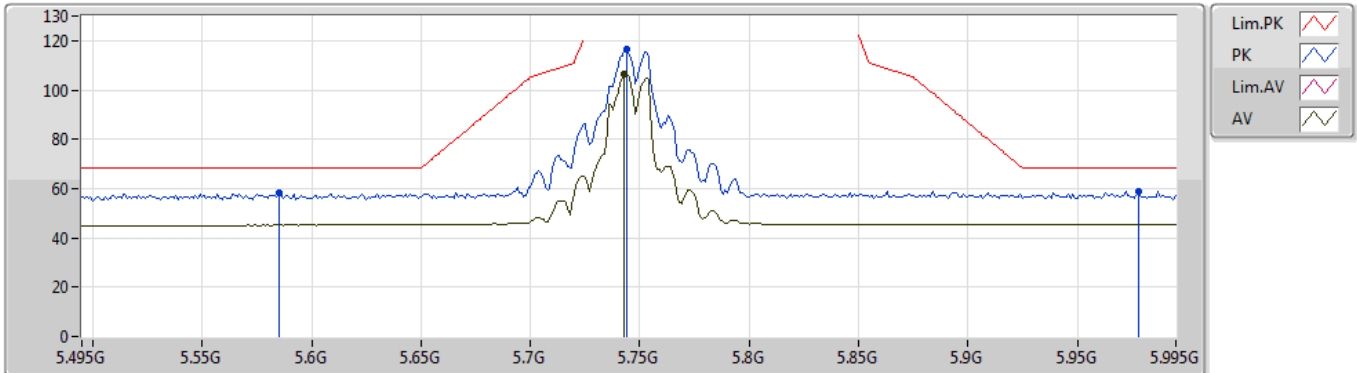

EUT Y_3TX
Setting 31.5
02-G-3-10
FSU(100015)

Type	Freq (Hz)	Level (dBuV/m)	Limit (dBuV/m)	Margin (dB)	Factor (dB)	Dist (m)	Condition	Azimuth (°)	Height (m)	Comment	Raw (dBuV)
PK	5.585G	58.03	68.20	-10.17	8.57	3	Vertical	84	2.41	-	49.46
PK	5.744G	116.28	Inf	-Inf	8.82	3	Vertical	84	2.41	-	107.46
AV	5.743G	106.21	Inf	-Inf	8.82	3	Vertical	84	2.41	-	97.39
PK	5.978G	58.86	68.20	-9.34	8.94	3	Vertical	84	2.41	-	49.92

802.11ac VHT20_Nss1,(MCS0)_3TX

31/10/2019

5745MHz_TX

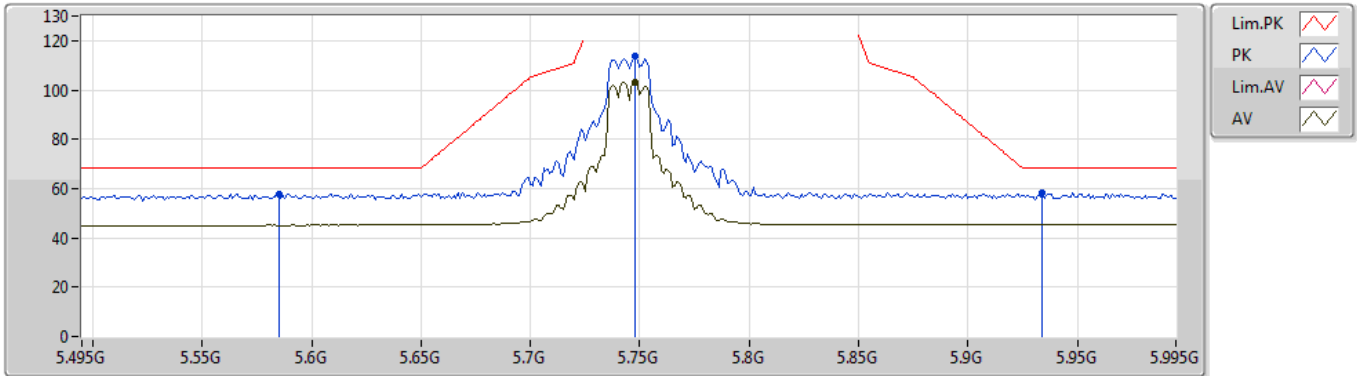

EUT Y_3TX
Setting 31.5
02-G-3-10
FSU(100015)

Type	Freq (Hz)	Level (dBuV/m)	Limit (dBuV/m)	Margin (dB)	Factor (dB)	Dist (m)	Condition	Azimuth (°)	Height (m)	Comment	Raw (dBuV)
PK	5.585G	57.88	68.20	-10.32	8.57	3	Horizontal	340	2.78	-	49.31
PK	5.748G	113.79	Inf	-Inf	8.82	3	Horizontal	340	2.78	-	104.97
AV	5.748G	103.01	Inf	-Inf	8.82	3	Horizontal	340	2.78	-	94.19
PK	5.934G	58.50	68.20	-9.70	8.93	3	Horizontal	340	2.78	-	49.57

802.11ac VHT20_Nss1,(MCS0)_3TX

31/10/2019

5745MHz_TX

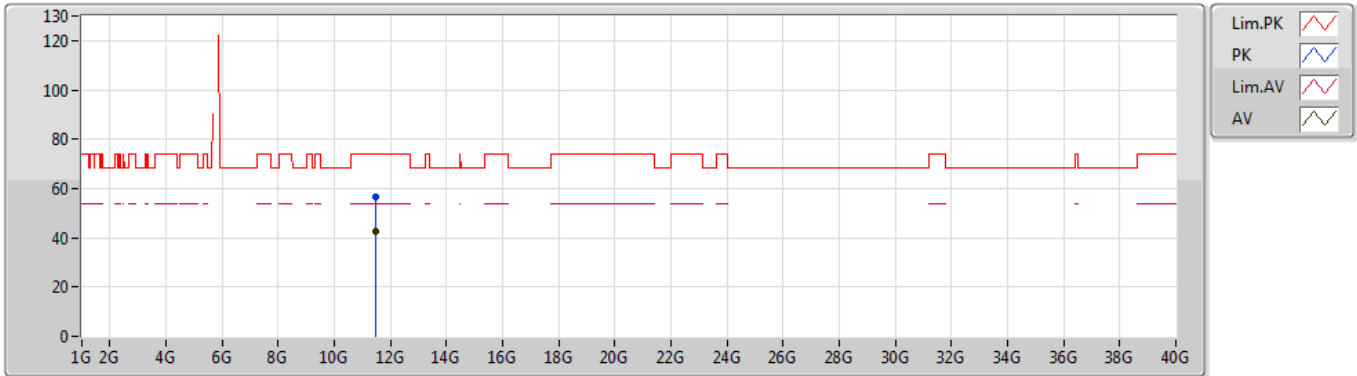

EUT Y_3TX
Setting 31.5
02-G-3
FSU(100015)

Type	Freq (Hz)	Level (dBuV/m)	Limit (dBuV/m)	Margin (dB)	Factor (dB)	Dist (m)	Condition	Azimuth (°)	Height (m)	Comment	Raw (dBuV)
PK	11.49002G	56.68	74.00	-17.32	14.89	3	Vertical	217	1.77	-	41.79
AV	11.48988G	42.69	54.00	-11.31	14.89	3	Vertical	217	1.77	-	27.80

802.11ac VHT20_Nss1,(MCS0)_3TX

31/10/2019

5745MHz_TX

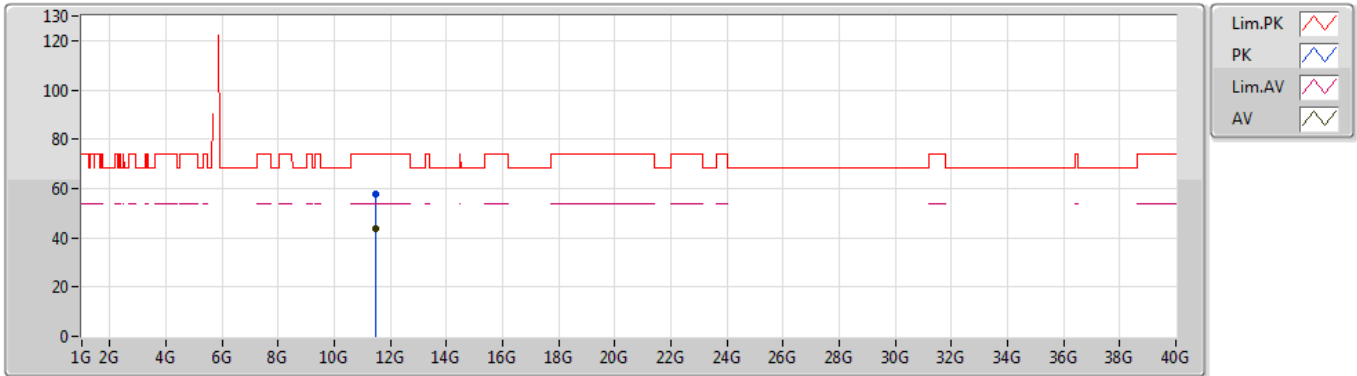

EUT Y_3TX
Setting 31.5
02-G-3
FSU(100015)

Type	Freq (Hz)	Level (dBuV/m)	Limit (dBuV/m)	Margin (dB)	Factor (dB)	Dist (m)	Condition	Azimuth (°)	Height (m)	Comment	Raw (dBuV)
PK	11.48712G	57.97	74.00	-16.03	14.89	3	Horizontal	153	1.78	-	43.08
AV	11.48676G	43.56	54.00	-10.44	14.89	3	Horizontal	153	1.78	-	28.67

802.11ac VHT20_Nss1,(MCS0)_3TX

31/10/2019

5785MHz_TX

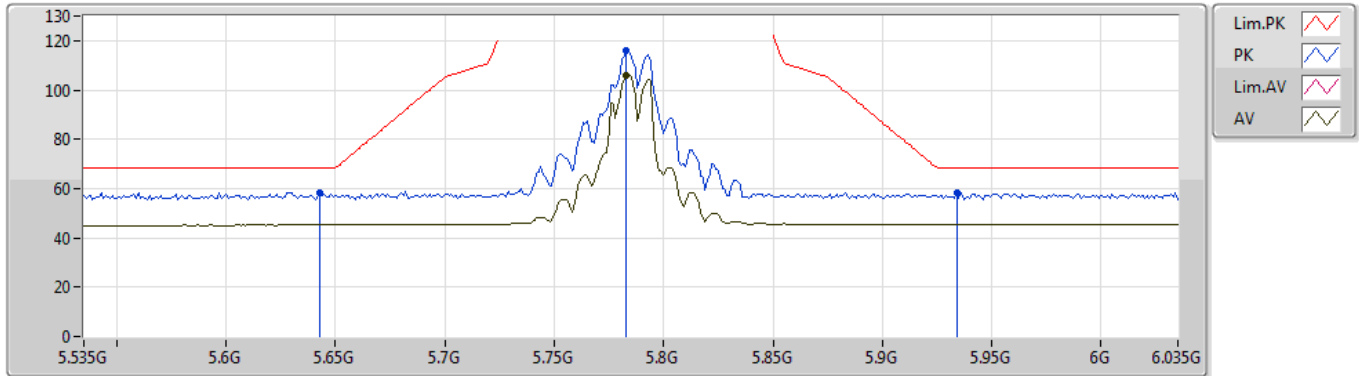

EUT Y_3TX
 Setting 31.5
 02-G-3-10
 FSU(100015)

Type	Freq (Hz)	Level (dBuV/m)	Limit (dBuV/m)	Margin (dB)	Factor (dB)	Dist (m)	Condition	Azimuth (°)	Height (m)	Comment	Raw (dBuV)
PK	5.643G	58.50	68.20	-9.70	8.66	3	Vertical	82	2.39	-	49.84
PK	5.783G	115.95	Inf	-Inf	8.88	3	Vertical	82	2.39	-	107.07
AV	5.783G	106.13	Inf	-Inf	8.88	3	Vertical	82	2.39	-	97.25
PK	5.934G	58.32	68.20	-9.88	8.93	3	Vertical	82	2.39	-	49.39

802.11ac VHT20_Nss1,(MCS0)_3TX

31/10/2019

5785MHz_TX

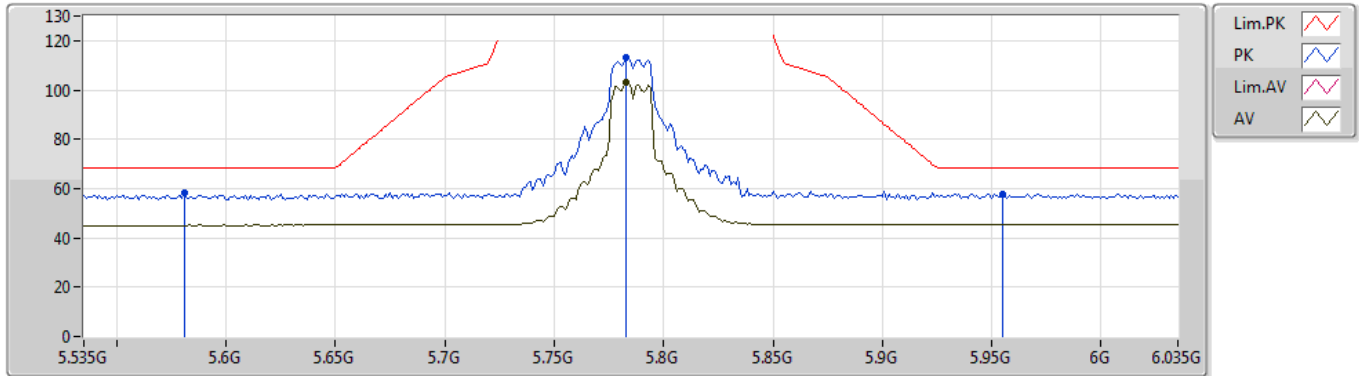

EUT Y_3TX
 Setting 31.5
 02-G-3-10
 FSU(100015)

Type	Freq (Hz)	Level (dBuV/m)	Limit (dBuV/m)	Margin (dB)	Factor (dB)	Dist (m)	Condition	Azimuth (°)	Height (m)	Comment	Raw (dBuV)
PK	5.581G	58.11	68.20	-10.09	8.57	3	Horizontal	348	2.54	-	49.54
PK	5.783G	113.37	Inf	-Inf	8.88	3	Horizontal	348	2.54	-	104.49
AV	5.783G	103.26	Inf	-Inf	8.88	3	Horizontal	348	2.54	-	94.38
PK	5.955G	57.97	68.20	-10.23	8.92	3	Horizontal	348	2.54	-	49.05

802.11ac VHT20_Nss1,(MCS0)_3TX

31/10/2019

5785MHz_TX

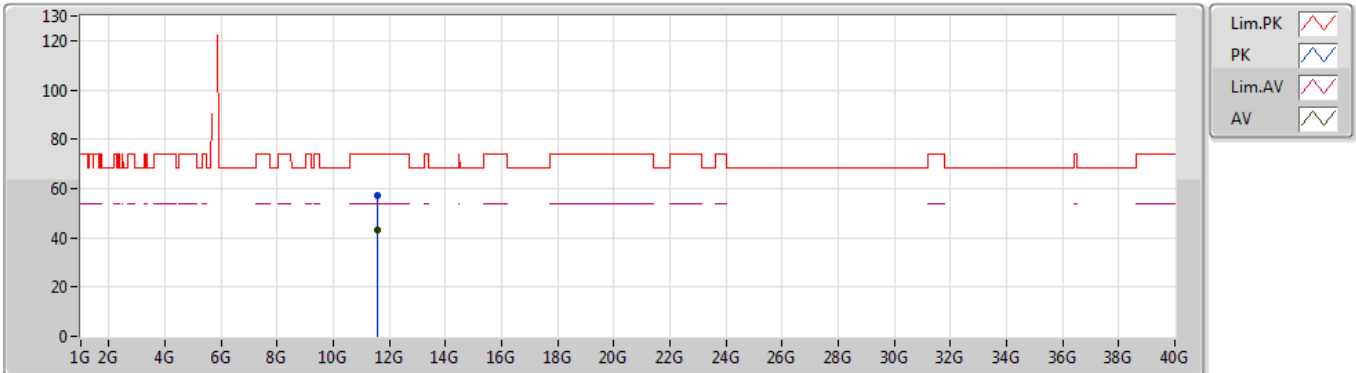

EUT Y_3TX
 Setting 31.5
 02-G-3
 FSU(100015)

Type	Freq (Hz)	Level (dBuV/m)	Limit (dBuV/m)	Margin (dB)	Factor (dB)	Dist (m)	Condition	Azimuth (°)	Height (m)	Comment	Raw (dBuV)
PK	11.57988G	57.20	74.00	-16.80	15.01	3	Vertical	195	1.52	-	42.19
AV	11.56996G	43.23	54.00	-10.77	15.00	3	Vertical	195	1.52	-	28.23

802.11ac VHT20_Nss1,(MCS0)_3TX

31/10/2019

5785MHz_TX

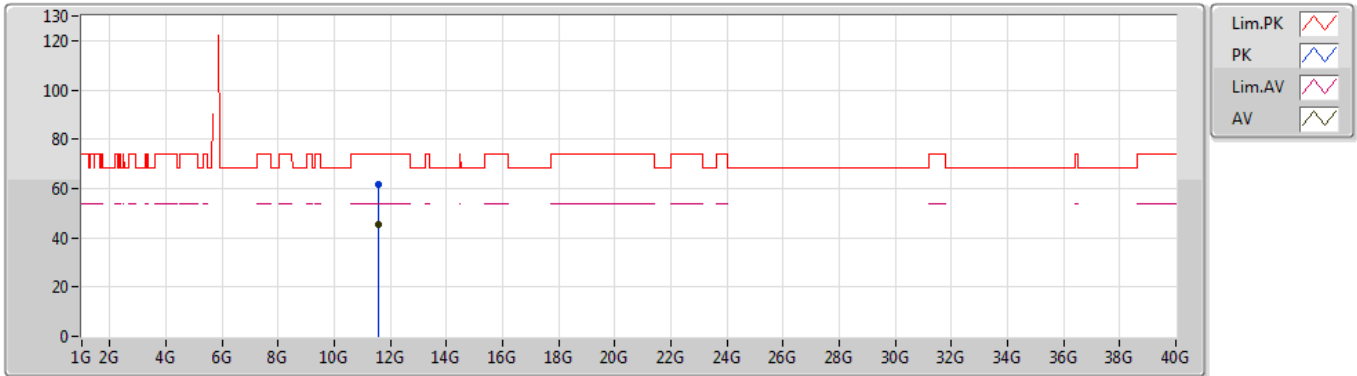

EUT Y_3TX
Setting 31.5
02-G-3
FSU(100015)

Type	Freq (Hz)	Level (dBuV/m)	Limit (dBuV/m)	Margin (dB)	Factor (dB)	Dist (m)	Condition	Azimuth (°)	Height (m)	Comment	Raw (dBuV)
PK	11.56802G	61.45	74.00	-12.55	14.99	3	Horizontal	160	2.92	-	46.46
AV	11.56724G	45.53	54.00	-8.47	14.99	3	Horizontal	160	2.92	-	30.54

802.11ac VHT20_Nss1,(MCS0)_3TX

31/10/2019

5825MHz_TX

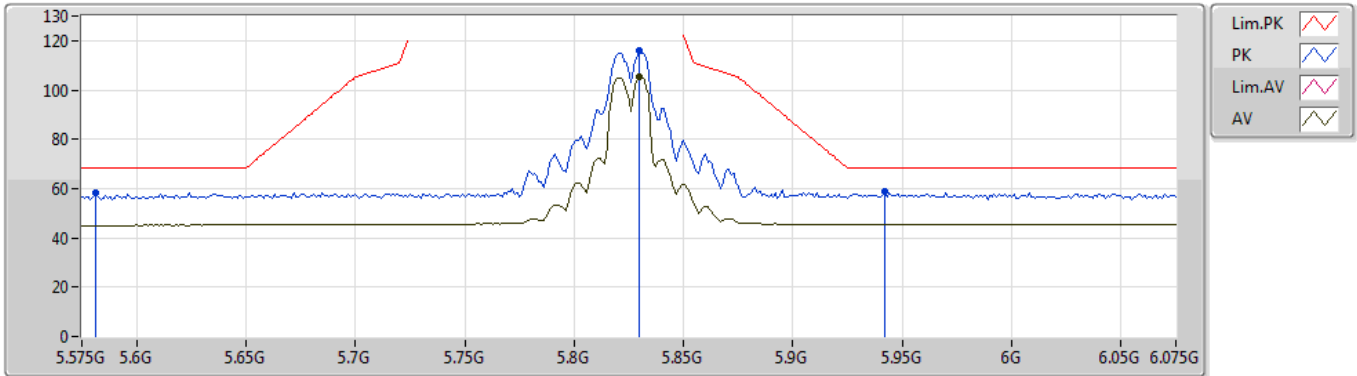

EUT Y_3TX
Setting 31.5
02-G-3-10
FSU(100015)

Type	Freq (Hz)	Level (dBuV/m)	Limit (dBuV/m)	Margin (dB)	Factor (dB)	Dist (m)	Condition	Azimuth (°)	Height (m)	Comment	Raw (dBuV)
PK	5.581G	58.44	68.20	-9.76	8.57	3	Vertical	66	1.68	-	49.87
PK	5.83G	116.10	Inf	-Inf	8.91	3	Vertical	66	1.68	-	107.19
AV	5.83G	105.53	Inf	-Inf	8.91	3	Vertical	66	1.68	-	96.62
PK	5.942G	58.67	68.20	-9.53	8.94	3	Vertical	66	1.68	-	49.73

802.11ac VHT20_Nss1,(MCS0)_3TX

31/10/2019

5825MHz_TX

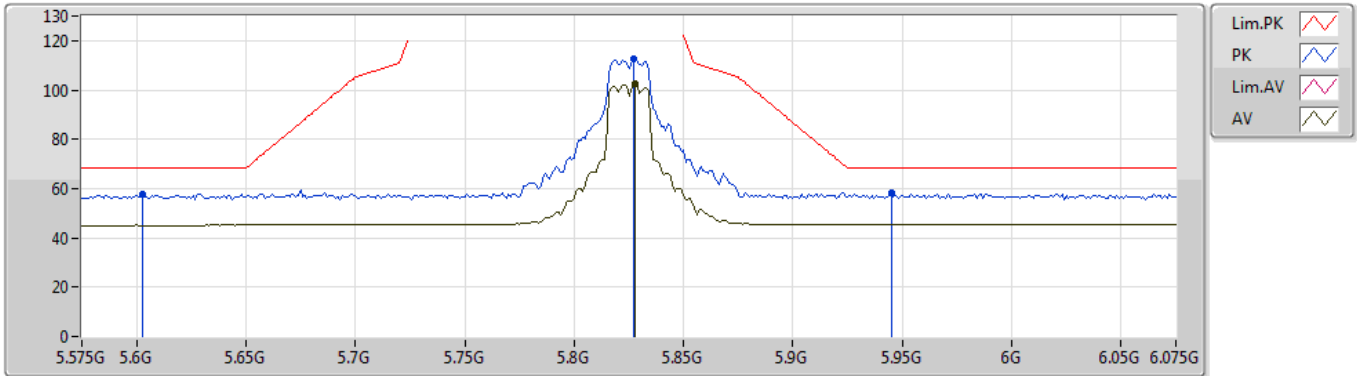

EUT Y_3TX
Setting 31.5
02-G-3-10
FSU(100015)

Type	Freq (Hz)	Level (dBuV/m)	Limit (dBuV/m)	Margin (dB)	Factor (dB)	Dist (m)	Condition	Azimuth (°)	Height (m)	Comment	Raw (dBuV)
PK	5.603G	57.89	68.20	-10.31	8.58	3	Horizontal	343	2.79	-	49.31
PK	5.827G	112.76	Inf	-Inf	8.91	3	Horizontal	343	2.79	-	103.85
AV	5.828G	102.46	Inf	-Inf	8.91	3	Horizontal	343	2.79	-	93.55
PK	5.945G	58.11	68.20	-10.09	8.94	3	Horizontal	343	2.79	-	49.17

802.11ac VHT20_Nss1,(MCS0)_3TX

31/10/2019

5825MHz_TX

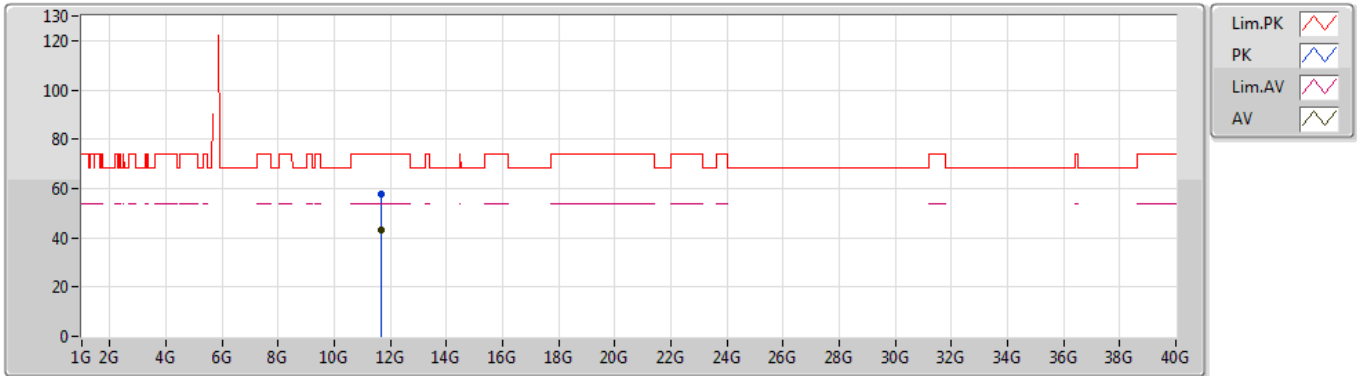

EUT Y_3TX
Setting 31.5
02-G-3-10
FSU(100015)

Type	Freq (Hz)	Level (dBuV/m)	Limit (dBuV/m)	Margin (dB)	Factor (dB)	Dist (m)	Condition	Azimuth (°)	Height (m)	Comment	Raw (dBuV)
PK	11.64912G	57.89	74.00	-16.11	15.09	3	Vertical	298	2.55	-	42.80
AV	11.64972G	42.90	54.00	-11.10	15.09	3	Vertical	298	2.55	-	27.81

802.11ac VHT20_Nss1,(MCS0)_3TX

31/10/2019

5825MHz_TX

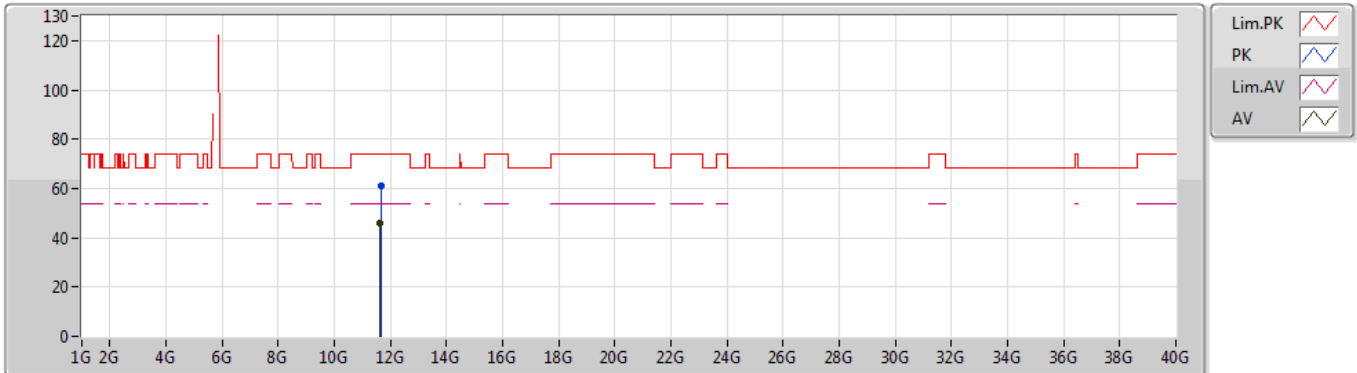

EUT Y_3TX
 Setting 31.5
 02-G-3-10
 FSU(100015)

Type	Freq (Hz)	Level (dBuV/m)	Limit (dBuV/m)	Margin (dB)	Factor (dB)	Dist (m)	Condition	Azimuth (°)	Height (m)	Comment	Raw (dBuV)
PK	11.6476G	61.07	74.00	-12.93	15.09	3	Horizontal	301	1.37	-	45.98
AV	11.6472G	46.11	54.00	-7.89	15.09	3	Horizontal	301	1.37	-	31.02

802.11ac VHT40_Nss1,(MCS0)_3TX

31/10/2019

5190MHz_TX

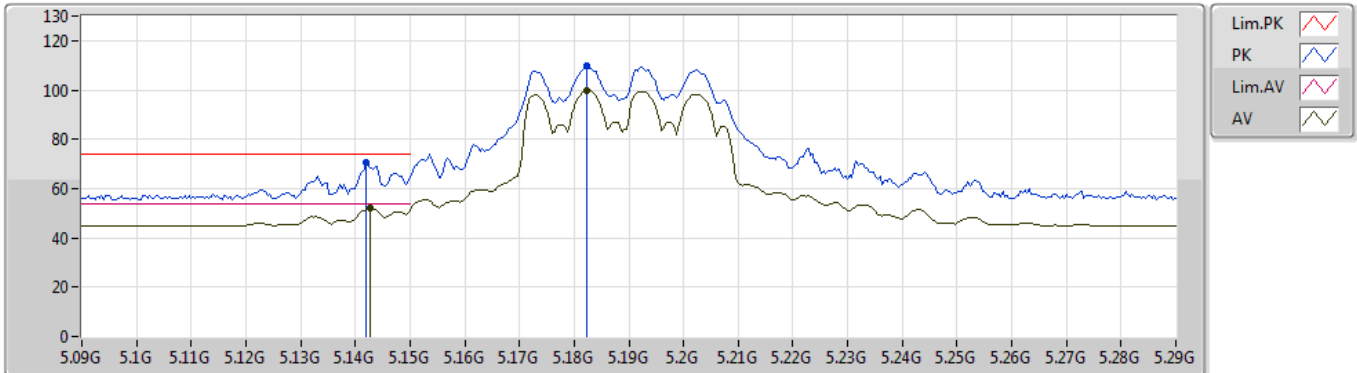

EUT Y_3TX
Setting 18
02-G-3-10
FSU(100015)

Type	Freq (Hz)	Level (dBuV/m)	Limit (dBuV/m)	Margin (dB)	Factor (dB)	Dist (m)	Condition	Azimuth (°)	Height (m)	Comment	Raw (dBuV)
PK	5.142G	70.66	74.00	-3.34	7.94	3	Vertical	60	1.57	-	62.72
AV	5.1428G	51.93	54.00	-2.07	7.94	3	Vertical	60	1.57	-	43.99
PK	5.1824G	109.85	Inf	-Inf	8.02	3	Vertical	60	1.57	-	101.83
AV	5.1824G	99.49	Inf	-Inf	8.02	3	Vertical	60	1.57	-	91.47

802.11ac VHT40_Nss1,(MCS0)_3TX

31/10/2019

5190MHz_TX

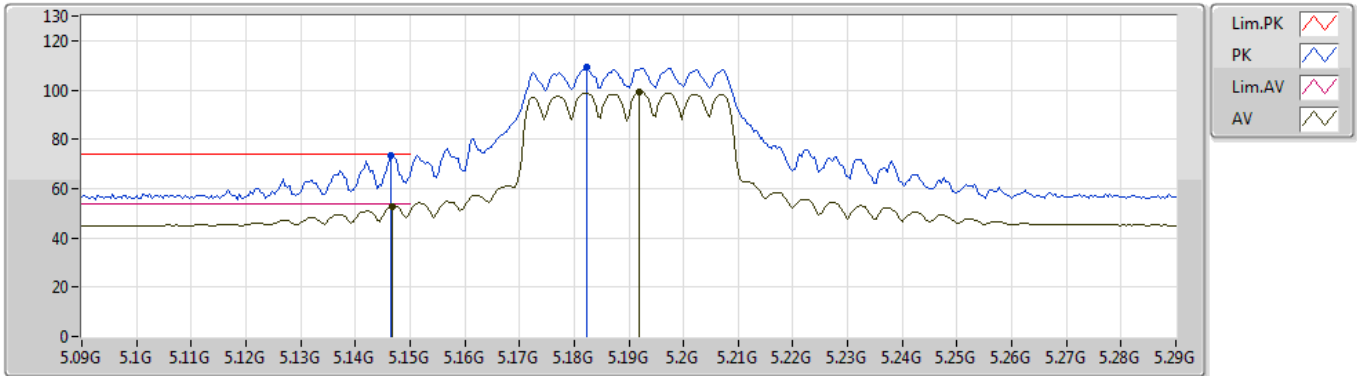

EUT Y_3TX
Setting 18
02-G-3-10
FSU(100015)

Type	Freq (Hz)	Level (dBuV/m)	Limit (dBuV/m)	Margin (dB)	Factor (dB)	Dist (m)	Condition	Azimuth (°)	Height (m)	Comment	Raw (dBuV)
PK	5.1464G	73.52	74.00	-0.48	7.94	3	Horizontal	332	1.51	-	65.58
AV	5.1468G	52.85	54.00	-1.15	7.94	3	Horizontal	332	1.51	-	44.91
PK	5.1824G	109.00	Inf	-Inf	8.02	3	Horizontal	332	1.51	-	100.98
AV	5.192G	98.99	Inf	-Inf	8.04	3	Horizontal	332	1.51	-	90.95

802.11ac VHT40_Nss1,(MCS0)_3TX

31/10/2019

5190MHz_TX

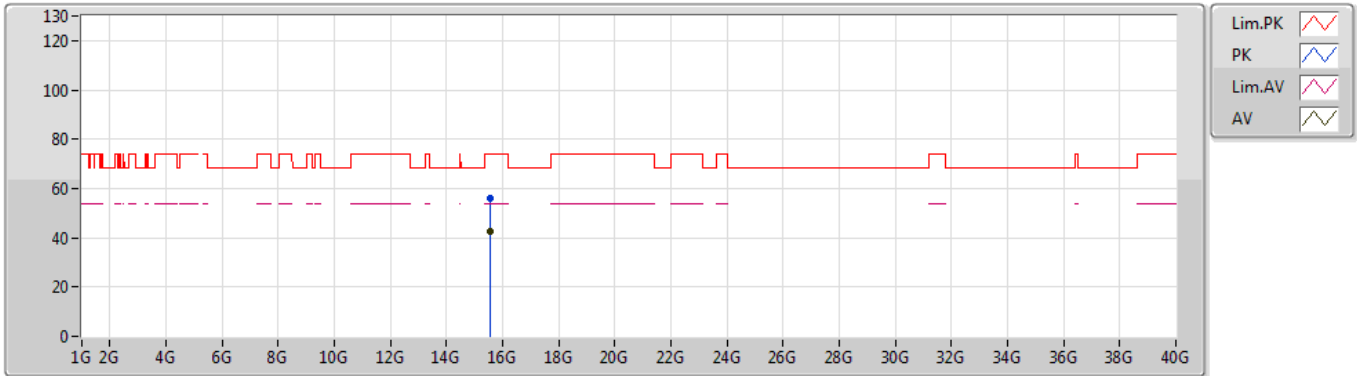

EUT Y_3TX
Setting 18
02-M-1
FSU(100015)

Type	Freq (Hz)	Level (dBuV/m)	Limit (dBuV/m)	Margin (dB)	Factor (dB)	Dist (m)	Condition	Azimuth (°)	Height (m)	Comment	Raw (dBuV)
PK	15.56933G	55.92	74.00	-18.08	16.00	3	Vertical	97	1.68	-	39.92
AV	15.56778G	42.37	54.00	-11.63	16.00	3	Vertical	97	1.68	-	26.37

802.11ac VHT40_Nss1,(MCS0)_3TX

31/10/2019

5190MHz_TX

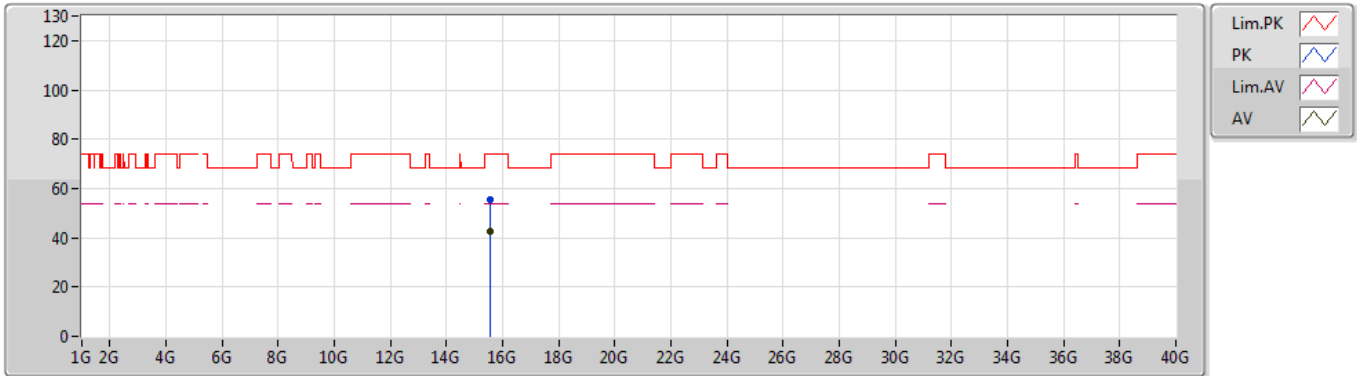

EUT Y_3TX
Setting 18
02-M-1
FSU(100015)

Type	Freq (Hz)	Level (dBuV/m)	Limit (dBuV/m)	Margin (dB)	Factor (dB)	Dist (m)	Condition	Azimuth (°)	Height (m)	Comment	Raw (dBuV)
PK	15.57008G	55.58	74.00	-18.42	16.00	3	Horizontal	131	1.08	-	39.58
AV	15.57167G	42.32	54.00	-11.68	15.99	3	Horizontal	131	1.08	-	26.33

802.11ac VHT40_Nss1,(MCS0)_3TX

31/10/2019

5230MHz_TX

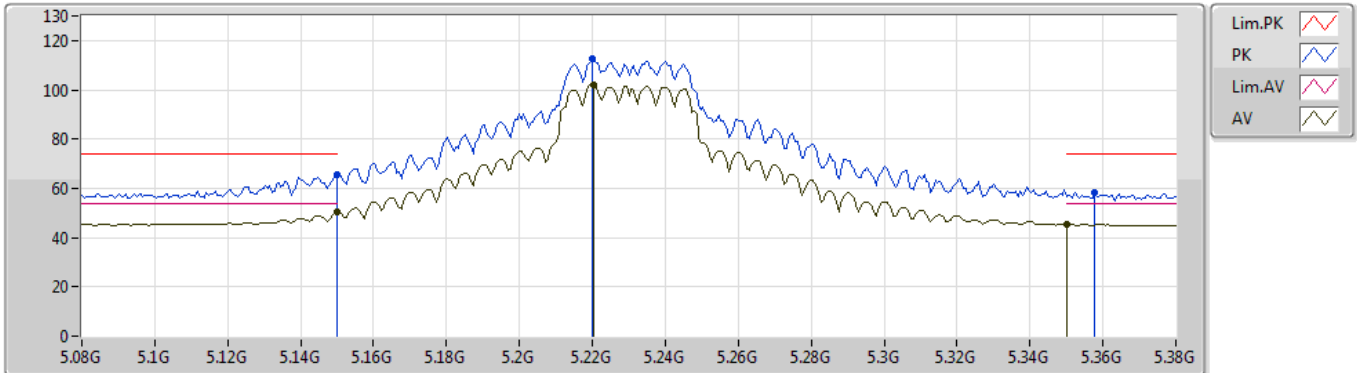

EUT_Y_3TX
Setting 31.5
02-G-3-10
FSU(100015)

Type	Freq (Hz)	Level (dBuV/m)	Limit (dBuV/m)	Margin (dB)	Factor (dB)	Dist (m)	Condition	Azimuth (°)	Height (m)	Comment	Raw (dBuV)
PK	5.15G	65.75	74.00	-8.25	7.94	3	Vertical	177	1.36	-	57.81
AV	5.15G	50.25	54.00	-3.75	7.94	3	Vertical	177	1.36	-	42.31
PK	5.2198G	112.53	Inf	-Inf	8.09	3	Vertical	177	1.36	-	104.44
AV	5.2204G	102.12	Inf	-Inf	8.09	3	Vertical	177	1.36	-	94.03
PK	5.3578G	58.33	74.00	-15.67	8.28	3	Vertical	177	1.36	-	50.05
AV	5.35G	45.55	54.00	-8.45	8.28	3	Vertical	177	1.36	-	37.27

802.11ac VHT40_Nss1,(MCS0)_3TX

31/10/2019

5230MHz_TX

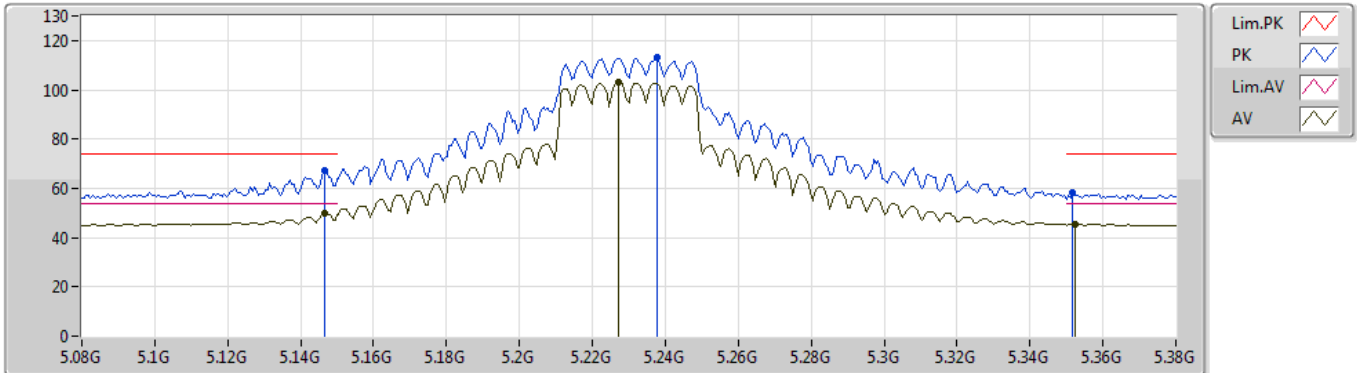

EUT_Y_3TX
Setting 31.5
02-G-3-10
FSU(100015)

Type	Freq (Hz)	Level (dBuV/m)	Limit (dBuV/m)	Margin (dB)	Factor (dB)	Dist (m)	Condition	Azimuth (°)	Height (m)	Comment	Raw (dBuV)
PK	5.1466G	67.24	74.00	-6.76	7.94	3	Horizontal	331	1.42	-	59.30
AV	5.1466G	49.80	54.00	-4.20	7.94	3	Horizontal	331	1.42	-	41.86
PK	5.2378G	113.08	Inf	-Inf	8.12	3	Horizontal	331	1.42	-	104.96
AV	5.227G	103.01	Inf	-Inf	8.10	3	Horizontal	331	1.42	-	94.91
PK	5.3518G	58.31	74.00	-15.69	8.28	3	Horizontal	331	1.42	-	50.03
AV	5.3524G	45.46	54.00	-8.54	8.28	3	Horizontal	331	1.42	-	37.18

802.11ac VHT40_Nss1,(MCS0)_3TX

31/10/2019

5230MHz_TX

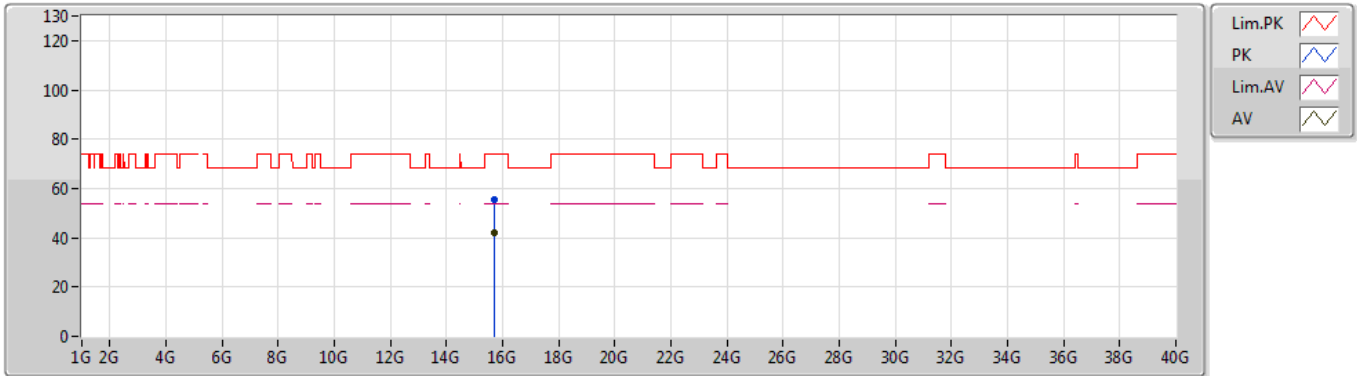

EUT Y_3TX
 Setting 31.5
 02-M-1
 FSU(100015)

Type	Freq (Hz)	Level (dBuV/m)	Limit (dBuV/m)	Margin (dB)	Factor (dB)	Dist (m)	Condition	Azimuth (°)	Height (m)	Comment	Raw (dBuV)
PK	15.68881G	55.61	74.00	-18.39	15.68	3	Vertical	184	2.50	-	39.93
AV	15.68976G	42.13	54.00	-11.87	15.68	3	Vertical	184	2.50	-	26.45

802.11ac VHT40_Nss1,(MCS0)_3TX

31/10/2019

5230MHz_TX

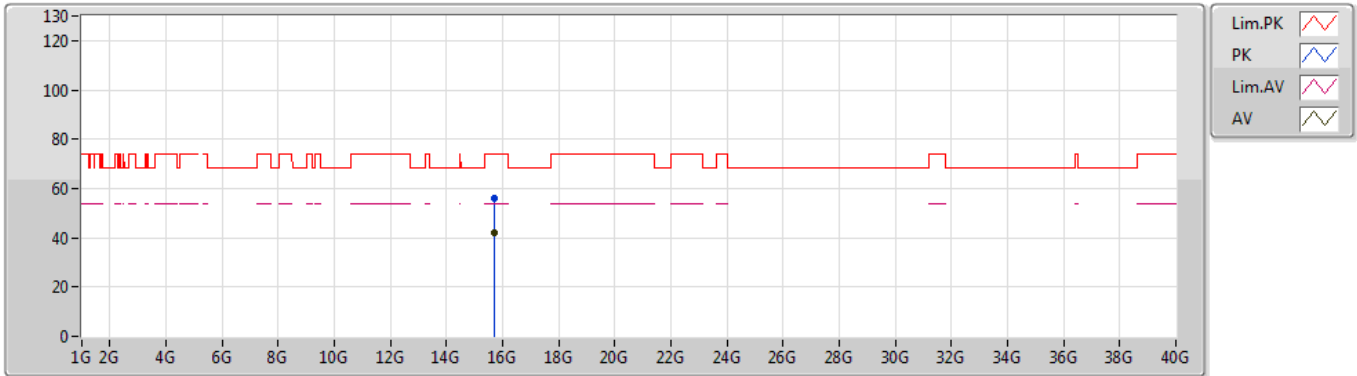

EUT Y_3TX
Setting 31.5
02-M-1
FSU(100015)

Type	Freq (Hz)	Level (dBuV/m)	Limit (dBuV/m)	Margin (dB)	Factor (dB)	Dist (m)	Condition	Azimuth (°)	Height (m)	Comment	Raw (dBuV)
PK	15.69027G	56.03	74.00	-17.97	15.68	3	Horizontal	2	2.47	-	40.35
AV	15.6875G	42.25	54.00	-11.75	15.69	3	Horizontal	2	2.47	-	26.56

802.11ac VHT40_Nss1,(MCS0)_3TX

31/10/2019

5755MHz_TX

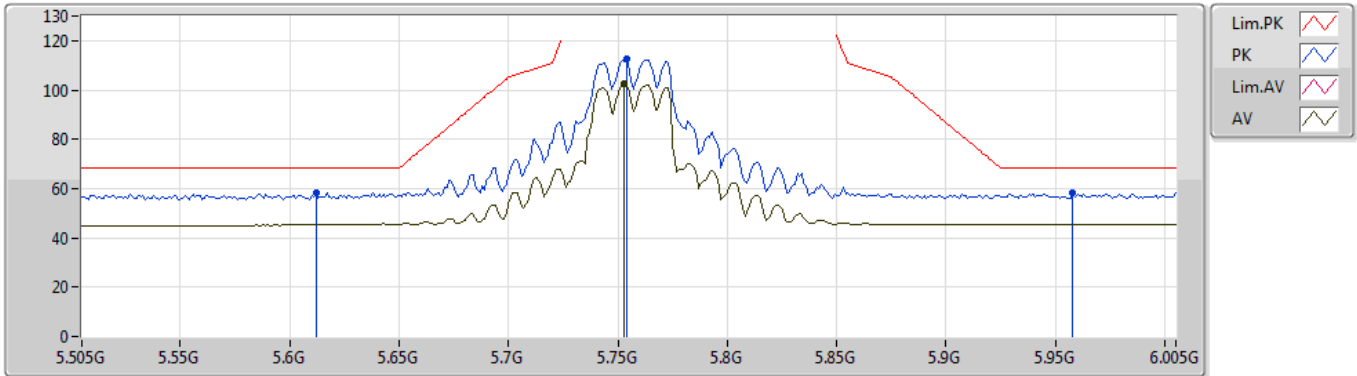

EUT Y_3TX
Setting 31.5
02-G-3-10
FSU(100015)

Type	Freq (Hz)	Level (dBuV/m)	Limit (dBuV/m)	Margin (dB)	Factor (dB)	Dist (m)	Condition	Azimuth (°)	Height (m)	Comment	Raw (dBuV)
PK	5.612G	58.46	68.20	-9.74	8.61	3	Vertical	79	2.48	-	49.85
PK	5.754G	112.49	Inf	-Inf	8.83	3	Vertical	79	2.48	-	103.66
AV	5.753G	102.54	Inf	-Inf	8.83	3	Vertical	79	2.48	-	93.71
PK	5.958G	58.29	68.20	-9.91	8.92	3	Vertical	79	2.48	-	49.37

802.11ac VHT40_Nss1,(MCS0)_3TX

31/10/2019

5755MHz_TX

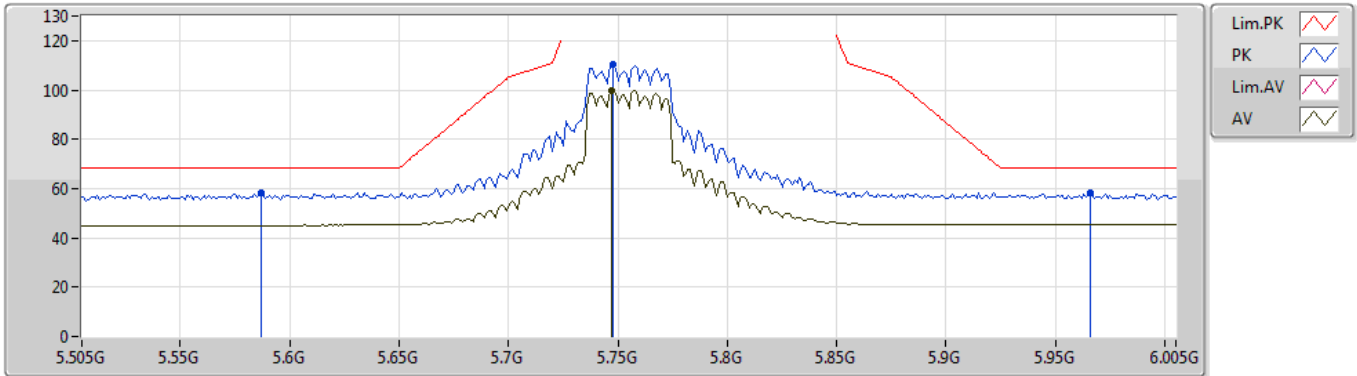

EUT_Y_3TX
Setting 31.5
02-G-3-10
FSU(100015)

Type	Freq (Hz)	Level (dBuV/m)	Limit (dBuV/m)	Margin (dB)	Factor (dB)	Dist (m)	Condition	Azimuth (°)	Height (m)	Comment	Raw (dBuV)
PK	5.587G	58.55	68.20	-9.65	8.57	3	Horizontal	348	2.99	-	49.98
PK	5.748G	110.13	Inf	-Inf	8.82	3	Horizontal	348	2.99	-	101.31
AV	5.747G	99.82	Inf	-Inf	8.82	3	Horizontal	348	2.99	-	91.00
PK	5.966G	58.02	68.20	-10.18	8.93	3	Horizontal	348	2.99	-	49.09

802.11ac VHT40_Nss1,(MCS0)_3TX

31/10/2019

5755MHz_TX

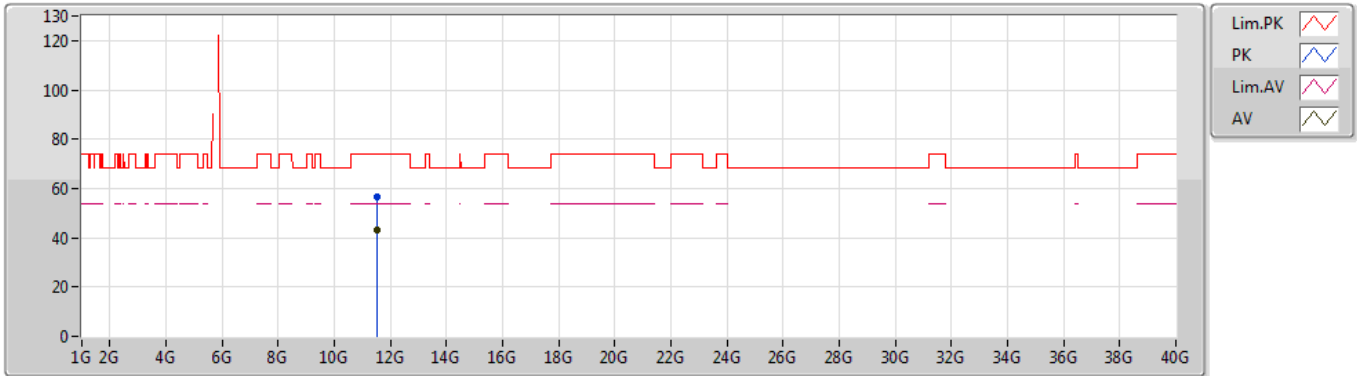

EUT Y_3TX
Setting 31.5
02-M-1
FSU(100015)

Type	Freq (Hz)	Level (dBuV/m)	Limit (dBuV/m)	Margin (dB)	Factor (dB)	Dist (m)	Condition	Azimuth (°)	Height (m)	Comment	Raw (dBuV)
PK	11.50922G	56.66	74.00	-17.34	14.92	3	Vertical	179	2.11	-	41.74
AV	11.5097G	43.27	54.00	-10.73	14.92	3	Vertical	179	2.11	-	28.35

802.11ac VHT40_Nss1,(MCS0)_3TX

31/10/2019

5755MHz_TX

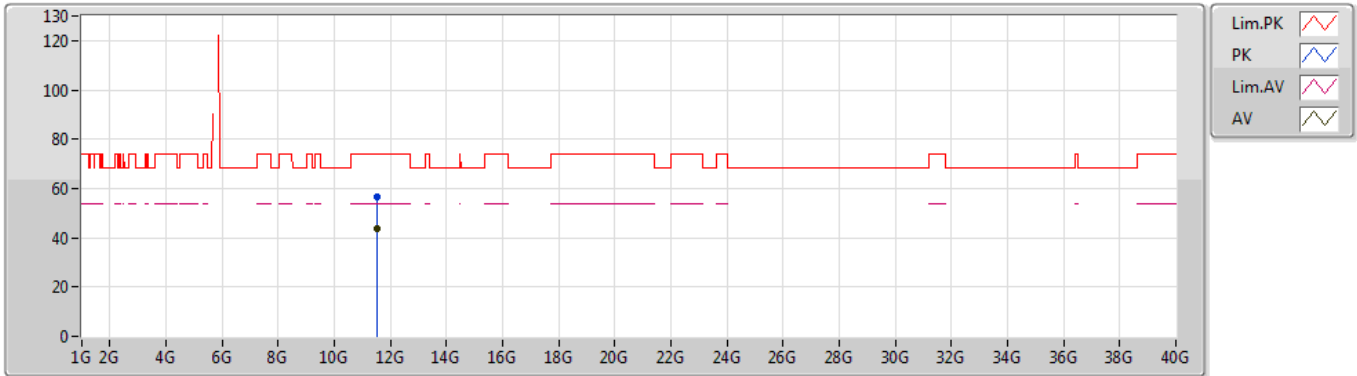

EUT Y_3TX
Setting 31.5
02-M-1
FSU(100015)

Type	Freq (Hz)	Level (dBuV/m)	Limit (dBuV/m)	Margin (dB)	Factor (dB)	Dist (m)	Condition	Azimuth (°)	Height (m)	Comment	Raw (dBuV)
PK	11.51066G	56.86	74.00	-17.14	14.92	3	Horizontal	165	1.34	-	41.94
AV	11.5088G	43.89	54.00	-10.11	14.92	3	Horizontal	165	1.34	-	28.97

802.11ac VHT40_Nss1,(MCS0)_3TX

31/10/2019

5795MHz_TX

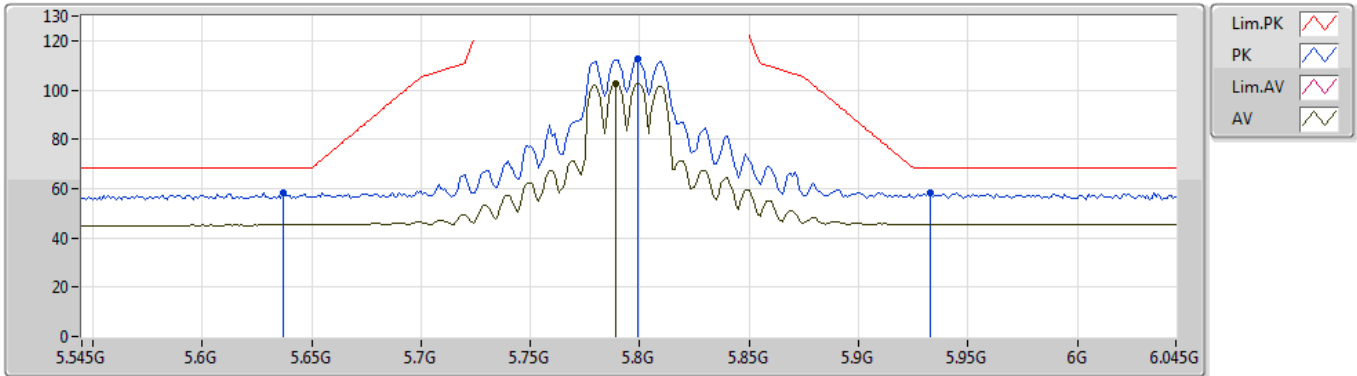

EUT Y_3TX
Setting 31.5
02-G-3-10
FSU(100015)

Type	Freq (Hz)	Level (dBuV/m)	Limit (dBuV/m)	Margin (dB)	Factor (dB)	Dist (m)	Condition	Azimuth (°)	Height (m)	Comment	Raw (dBuV)
PK	5.637G	58.29	68.20	-9.91	8.64	3	Vertical	81	1.58	-	49.65
PK	5.799G	112.45	Inf	-Inf	8.90	3	Vertical	81	1.58	-	103.55
AV	5.789G	102.82	Inf	-Inf	8.88	3	Vertical	81	1.58	-	93.94
PK	5.933G	58.24	68.20	-9.96	8.93	3	Vertical	81	1.58	-	49.31

802.11ac VHT40_Nss1,(MCS0)_3TX

31/10/2019

5795MHz_TX

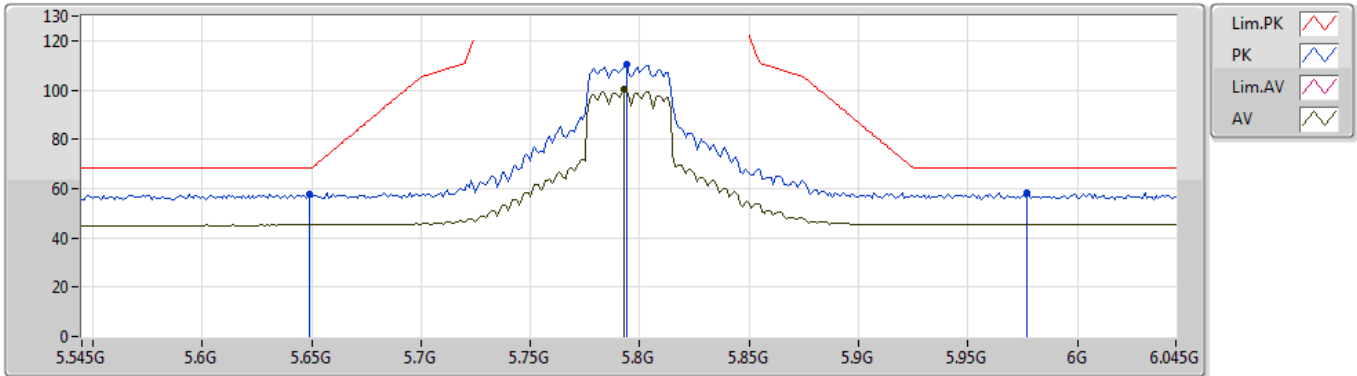

EUT Y_3TX
 Setting 31.5
 02-G-3-10
 FSU(100015)

Type	Freq (Hz)	Level (dBuV/m)	Limit (dBuV/m)	Margin (dB)	Factor (dB)	Dist (m)	Condition	Azimuth (°)	Height (m)	Comment	Raw (dBuV)
PK	5.649G	57.69	68.20	-10.51	8.67	3	Horizontal	338	2.52	-	49.02
PK	5.794G	110.25	Inf	-Inf	8.89	3	Horizontal	338	2.52	-	101.36
AV	5.793G	100.21	Inf	-Inf	8.89	3	Horizontal	338	2.52	-	91.32
PK	5.977G	58.17	68.20	-10.03	8.94	3	Horizontal	338	2.52	-	49.23

802.11ac VHT40_Nss1,(MCS0)_3TX

31/10/2019

5795MHz_TX

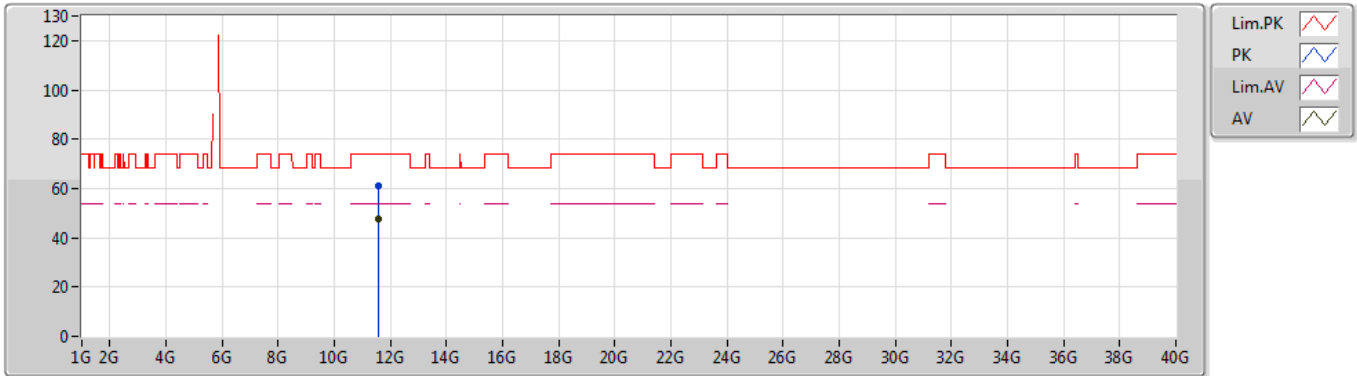

EUT Y_3TX
Setting 31.5
02-M-1
FSU(100015)

Type	Freq (Hz)	Level (dBuV/m)	Limit (dBuV/m)	Margin (dB)	Factor (dB)	Dist (m)	Condition	Azimuth (°)	Height (m)	Comment	Raw (dBuV)
PK	11.59584G	61.02	74.00	-12.98	15.04	3	Vertical	283	1.34	-	45.98
AV	11.58704G	47.51	54.00	-6.49	15.02	3	Vertical	283	1.34	-	32.49

802.11ac VHT40_Nss1,(MCS0)_3TX

31/10/2019

5795MHz_TX

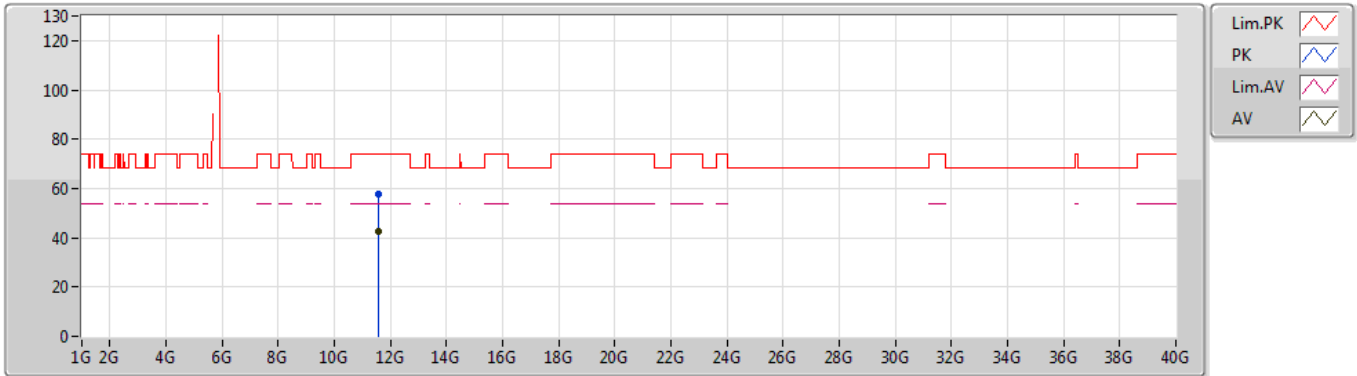

EUT Y_3TX
Setting 31.5
02-M-1
FSU(100015)

Type	Freq (Hz)	Level (dBuV/m)	Limit (dBuV/m)	Margin (dB)	Factor (dB)	Dist (m)	Condition	Azimuth (°)	Height (m)	Comment	Raw (dBuV)
PK	11.5891G	57.63	74.00	-16.37	15.02	3	Horizontal	177	1.67	-	42.61
AV	11.58934G	42.80	54.00	-11.20	15.02	3	Horizontal	177	1.67	-	27.78

802.11ac VHT80_Nss1,(MCS0)_3TX

31/10/2019

5210MHz_TX

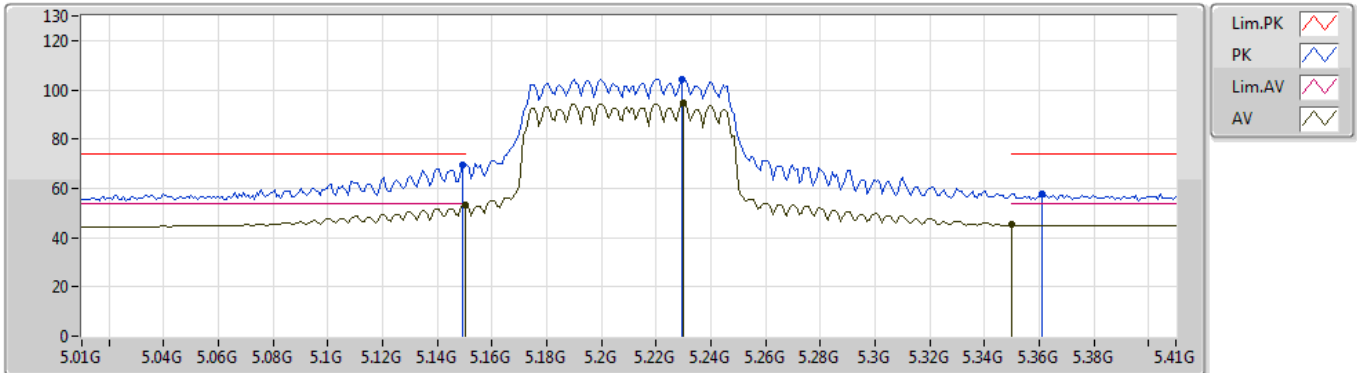

EUT_Y_3TX
Setting 17.5
02-G-3-10
FSU(100015)

Type	Freq (Hz)	Level (dBuV/m)	Limit (dBuV/m)	Margin (dB)	Factor (dB)	Dist (m)	Condition	Azimuth (°)	Height (m)	Comment	Raw (dBuV)
PK	5.1492G	69.51	74.00	-4.49	7.94	3	Vertical	178	1.46	-	61.57
AV	5.15G	53.04	54.00	-0.96	7.94	3	Vertical	178	1.46	-	45.10
PK	5.2292G	104.39	Inf	-Inf	8.11	3	Vertical	178	1.46	-	96.28
AV	5.23G	94.47	Inf	-Inf	8.11	3	Vertical	178	1.46	-	86.36
PK	5.3612G	57.94	74.00	-16.06	8.29	3	Vertical	178	1.46	-	49.65
AV	5.35G	45.36	54.00	-8.64	8.28	3	Vertical	178	1.46	-	37.08

802.11ac VHT80_Nss1,(MCS0)_3TX

31/10/2019

5210MHz_TX

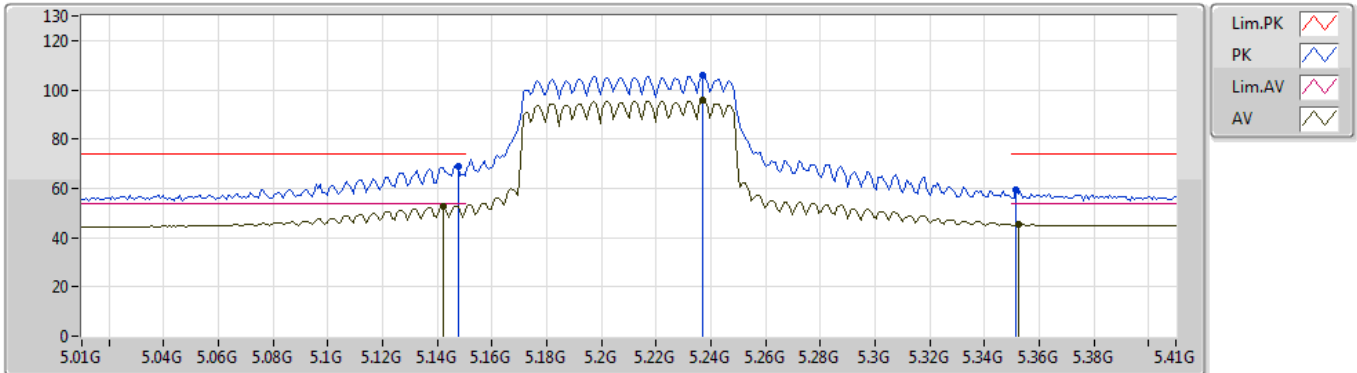

EUT Y_3TX
Setting 17.5
02-G-3-10
FSU(100015)

Type	Freq (Hz)	Level (dBuV/m)	Limit (dBuV/m)	Margin (dB)	Factor (dB)	Dist (m)	Condition	Azimuth (°)	Height (m)	Comment	Raw (dBuV)
PK	5.1476G	69.01	74.00	-4.99	7.94	3	Horizontal	313	1.37	-	61.07
AV	5.142G	52.84	54.00	-1.16	7.94	3	Horizontal	313	1.37	-	44.90
PK	5.2372G	105.80	Inf	-Inf	8.11	3	Horizontal	313	1.37	-	97.69
AV	5.2372G	95.57	Inf	-Inf	8.11	3	Horizontal	313	1.37	-	87.46
PK	5.3516G	59.15	74.00	-14.85	8.28	3	Horizontal	313	1.37	-	50.87
AV	5.3524G	45.49	54.00	-8.51	8.28	3	Horizontal	313	1.37	-	37.21

802.11ac VHT80_Nss1,(MCS0)_3TX

31/10/2019

5210MHz_TX

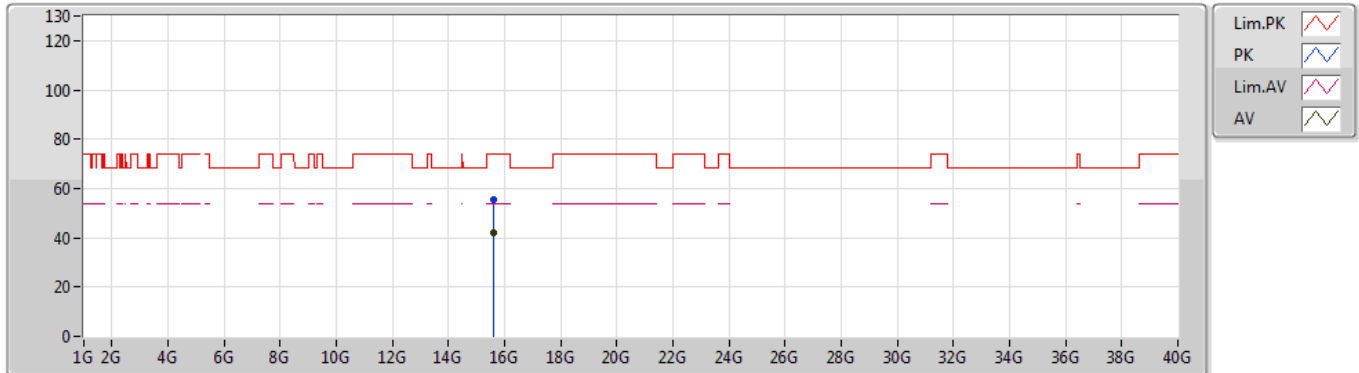

EUT Y_3TX
Setting 17.5
02-M-1
FSU(100015)

Type	Freq (Hz)	Level (dBuV/m)	Limit (dBuV/m)	Margin (dB)	Factor (dB)	Dist (m)	Condition	Azimuth (°)	Height (m)	Comment	Raw (dBuV)
PK	15.62874G	55.57	74.00	-18.43	15.84	3	Vertical	37	1.87	-	39.73
AV	15.62975G	41.76	54.00	-12.24	15.83	3	Vertical	37	1.87	-	25.93

802.11ac VHT80_Nss1,(MCS0)_3TX

31/10/2019

5210MHz_TX

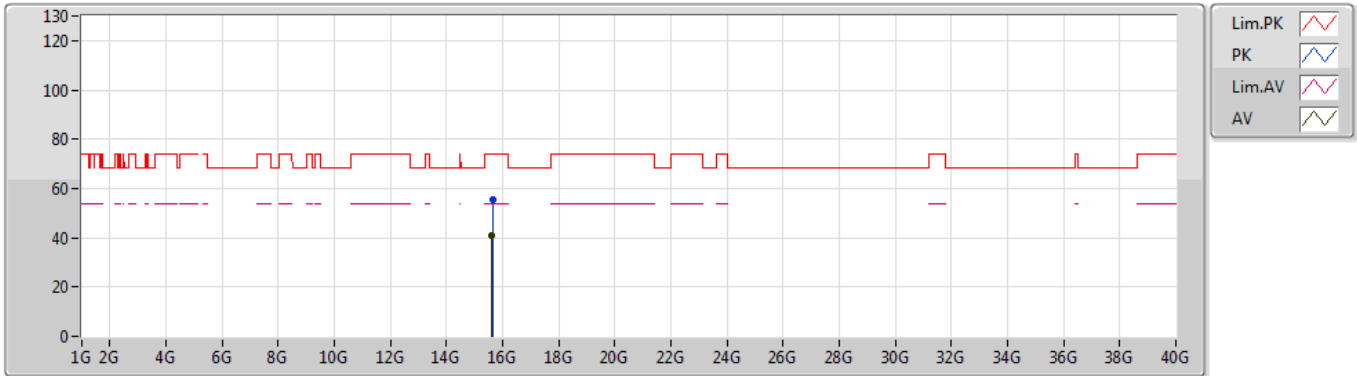

EUT Y_3TX
Setting 17.5
02-M-1
FSU(100015)

Type	Freq (Hz)	Level (dBuV/m)	Limit (dBuV/m)	Margin (dB)	Factor (dB)	Dist (m)	Condition	Azimuth (°)	Height (m)	Comment	Raw (dBuV)
PK	15.63155G	55.73	74.00	-18.27	15.83	3	Horizontal	323	1.47	-	39.90
AV	15.62926G	41.04	54.00	-12.96	15.84	3	Horizontal	323	1.47	-	25.20

802.11ac VHT80_Nss1,(MCS0)_3TX

31/10/2019

5775MHz_TX

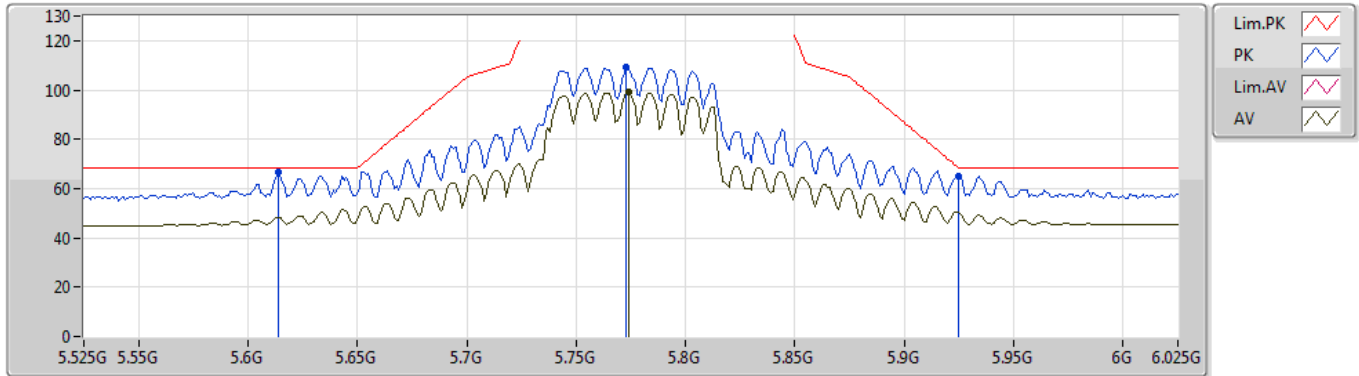

EUT Y_3TX
Setting 31.5
02-G-3-10
FSU(100015)

Type	Freq (Hz)	Level (dBuV/m)	Limit (dBuV/m)	Margin (dB)	Factor (dB)	Dist (m)	Condition	Azimuth (°)	Height (m)	Comment	Raw (dBuV)
PK	5.614G	66.42	68.20	-1.78	8.61	3	Vertical	79	2.61	-	57.81
PK	5.773G	109.30	Inf	-Inf	8.85	3	Vertical	79	2.61	-	100.45
AV	5.774G	99.19	Inf	-Inf	8.86	3	Vertical	79	2.61	-	90.33
PK	5.925G	65.18	68.20	-3.02	8.93	3	Vertical	79	2.61	-	56.25

802.11ac VHT80_Nss1,(MCS0)_3TX

31/10/2019

5775MHz_TX

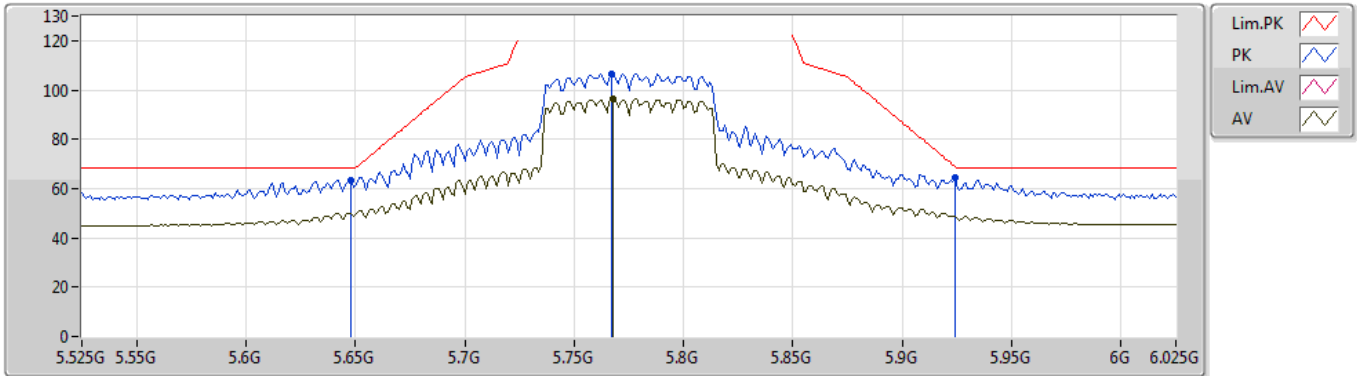

EUT Y_3TX
Setting 31.5
02-G-3-10
FSU(100015)

Type	Freq (Hz)	Level (dBuV/m)	Limit (dBuV/m)	Margin (dB)	Factor (dB)	Dist (m)	Condition	Azimuth (°)	Height (m)	Comment	Raw (dBuV)
PK	5.648G	63.30	68.20	-4.90	8.67	3	Horizontal	339	2.83	-	54.63
PK	5.767G	106.69	Inf	-Inf	8.85	3	Horizontal	339	2.83	-	97.84
AV	5.768G	96.53	Inf	-Inf	8.85	3	Horizontal	339	2.83	-	87.68
PK	5.924G	64.53	68.94	-4.41	8.92	3	Horizontal	339	2.83	-	55.61

802.11ac VHT80_Nss1,(MCS0)_3TX

31/10/2019

5775MHz_TX

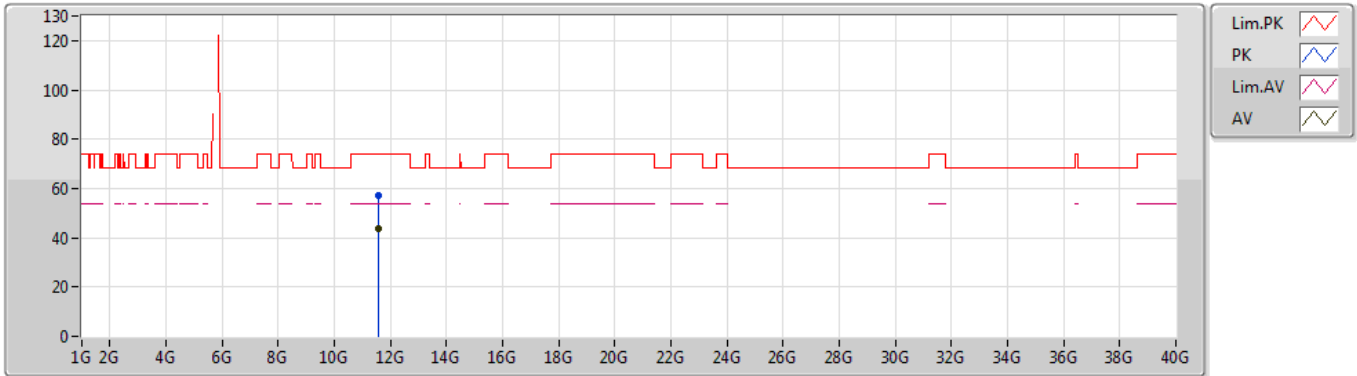

EUT Y_3TX
 Setting 31.5
 02-M-1
 FSU(100015)

Type	Freq (Hz)	Level (dBuV/m)	Limit (dBuV/m)	Margin (dB)	Factor (dB)	Dist (m)	Condition	Azimuth (°)	Height (m)	Comment	Raw (dBuV)
PK	11.54994G	57.21	74.00	-16.79	14.97	3	Vertical	139	2.34	-	42.24
AV	11.5494G	43.66	54.00	-10.34	14.97	3	Vertical	139	2.34	-	28.69

802.11ac VHT80_Nss1,(MCS0)_3TX

31/10/2019

5775MHz_TX

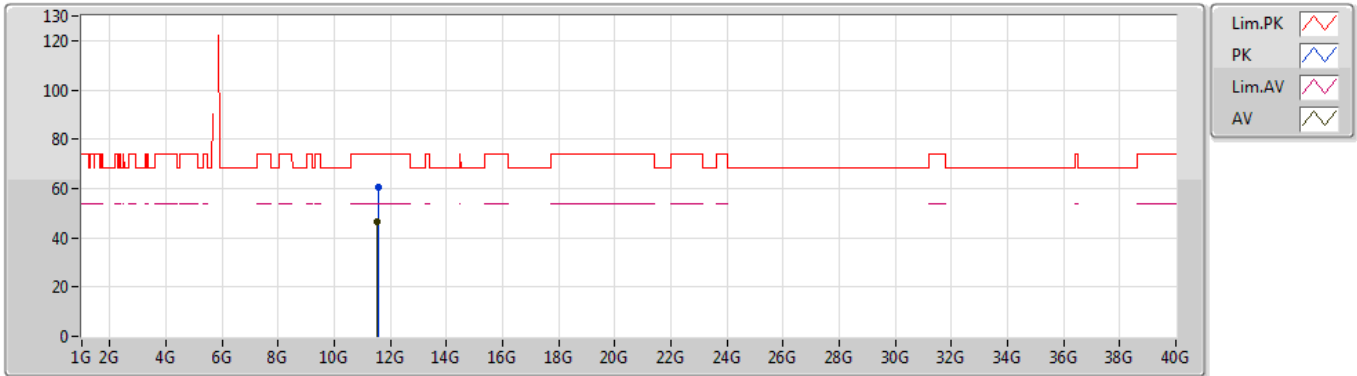

EUT Y_3TX
Setting 31.5
02-M-1
FSU(100015)

Type	Freq (Hz)	Level (dBuV/m)	Limit (dBuV/m)	Margin (dB)	Factor (dB)	Dist (m)	Condition	Azimuth (°)	Height (m)	Comment	Raw (dBuV)
PK	11.55624G	60.34	74.00	-13.66	14.97	3	Horizontal	301	1.28	-	45.37
AV	11.54694G	46.50	54.00	-7.50	14.97	3	Horizontal	301	1.28	-	31.53

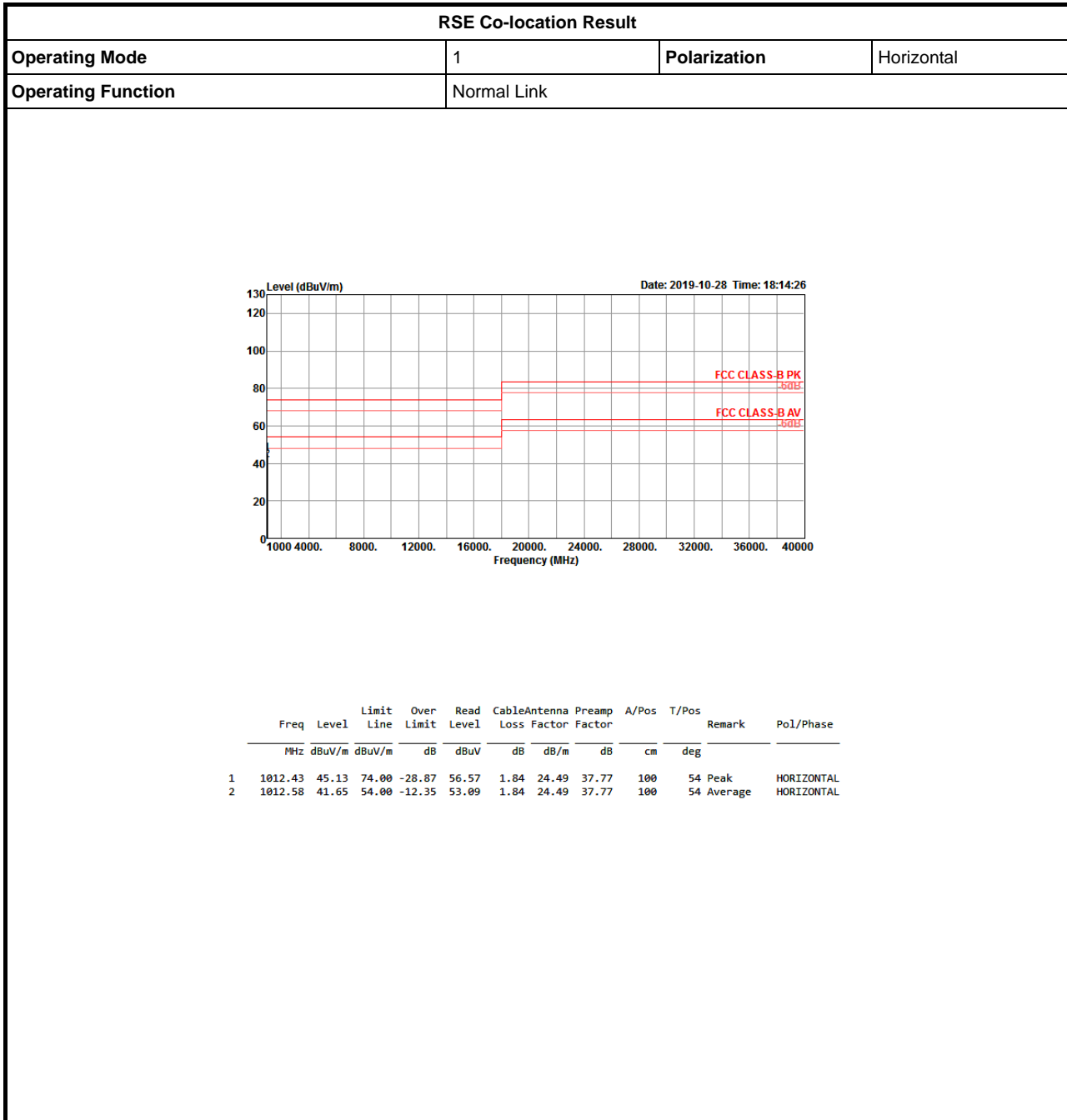



RSE Co-location Result

RSE Co-location Result																																																			
Operating Mode	1	Polarization	Vertical																																																
Operating Function	Normal Link																																																		
<div style="display: flex; justify-content: space-between; align-items: flex-start;"> <div> <p>Level (dBuV/m)</p> </div> <div style="text-align: right;"> <p>Date: 2019-10-28 Time: 18:11:20</p> </div> </div>																																																			
<table border="1" style="width: 100%; border-collapse: collapse; font-size: small;"> <thead> <tr> <th></th> <th>Freq</th> <th>Level</th> <th>Limit</th> <th>Over</th> <th>Read</th> <th>CableAntenna</th> <th>Preamp</th> <th>A/Pos</th> <th>T/Pos</th> <th>Remark</th> <th>Pol/Phase</th> </tr> <tr> <th></th> <th>MHz</th> <th>dBuV/m</th> <th>dBuV/m</th> <th>dB</th> <th>dBuV</th> <th>dB</th> <th>dB/m</th> <th>dB</th> <th>cm</th> <th>deg</th> <th></th> </tr> </thead> <tbody> <tr> <td>1</td> <td>1012.48</td> <td>49.19</td> <td>54.00</td> <td>-4.81</td> <td>60.63</td> <td>1.84</td> <td>24.49</td> <td>37.77</td> <td>100</td> <td>315 Average</td> <td>VERTICAL</td> </tr> <tr> <td>2</td> <td>1012.54</td> <td>51.12</td> <td>74.00</td> <td>-22.88</td> <td>62.56</td> <td>1.84</td> <td>24.49</td> <td>37.77</td> <td>100</td> <td>315 Peak</td> <td>VERTICAL</td> </tr> </tbody> </table>					Freq	Level	Limit	Over	Read	CableAntenna	Preamp	A/Pos	T/Pos	Remark	Pol/Phase		MHz	dBuV/m	dBuV/m	dB	dBuV	dB	dB/m	dB	cm	deg		1	1012.48	49.19	54.00	-4.81	60.63	1.84	24.49	37.77	100	315 Average	VERTICAL	2	1012.54	51.12	74.00	-22.88	62.56	1.84	24.49	37.77	100	315 Peak	VERTICAL
	Freq	Level	Limit	Over	Read	CableAntenna	Preamp	A/Pos	T/Pos	Remark	Pol/Phase																																								
	MHz	dBuV/m	dBuV/m	dB	dBuV	dB	dB/m	dB	cm	deg																																									
1	1012.48	49.19	54.00	-4.81	60.63	1.84	24.49	37.77	100	315 Average	VERTICAL																																								
2	1012.54	51.12	74.00	-22.88	62.56	1.84	24.49	37.77	100	315 Peak	VERTICAL																																								