



# **FCC RADIO TEST REPORT-WIFI**

## **FCC ID:2AHJX-ALPHA2**

**Product :** Alpha Intelligent Robot 2

**Trade Name :** UBTECH

**Model Name :** Alpha 2

**Serial Model :** N/A

**Report No. :** NTEK-2015NT12173475F2

### **Prepared for**

UBTECH ROBOTICS CORP

16th & 22nd Floor, Block C1, Nanshan I Park, No.1001 Xueyuan Road,  
Nanshan District, Shenzhen City, PR. CHINA

### **Prepared by**

Shenzhen NTEK Testing Technology Co., Ltd.

1/F, Building E, Fenda Science Park, Sanwei Community, Xixiang Street  
Bao'an District, Shenzhen P.R. China

Tel.: +86-0755-61156588 Fax.: +86-0755-61156599

Website:www.ntek.org.cn

### TEST RESULT CERTIFICATION

**Applicant's name** ..... UBTECH ROBOTICS CORP

Address..... 16th & 22nd Floor, Block C1, Nanshan I Park, No.1001 Xueyuan Road, Nanshan District, Shenzhen City, PR. CHINA

**Manufacture's Name** ... UBTECH ROBOTICS CORP BAOAN BRANCH

Address..... 5/F, Building C, Huilongda Industry Park, Shilongzai, Shiyan Street, Baoan District, Shenzhen City.

**Product description**

Product name ..... Alpha Intelligent Robot 2

Model and/or type reference ..... Alpha 2

Serial Model ..... N/A

**Standards** ..... FCC Part15.247 01 Oct. 2015

Test procedure ..... ANSI C63.10-2013 and KDB 558074: June 5, 2014

This device described above has been tested by NTEK, and the test results show that the equipment under test (EUT) is in compliance with the FCC requirements. And it is applicable only to the tested sample identified in the report.

This report shall not be reproduced except in full, without the written approval of NTEK, this document may be altered or revised by NTEK, personnel only, and shall be noted in the revision of the document.

**Date of Test** .....

Date (s) of performance of tests..... 17 Dec. 2015 ~14 Mar. 2016

Date of Issue ..... 14 Mar. 2016

Test Result ..... **Pass**

Testing Engineer : *Eileen Liu.*  
(Eileen Liu)

Technical Manager : *Jason chen*  
(Jason Chen)

Authorized Signatory : *Sam. chen*  
(Sam Chen)

**Table of Contents**

	<b>Page</b>
<b>1 . SUMMARY OF TEST RESULTS</b>	<b>6</b>
1.1 TEST FACILITY	7
1.2 MEASUREMENT UNCERTAINTY	7
<b>2 . GENERAL INFORMATION</b>	<b>8</b>
2.1 GENERAL DESCRIPTION OF EUT	8
2.2 DESCRIPTION OF TEST MODES	10
2.3 BLOCK DIGRAM SHOWING THE CONFIGURATION OF SYSTEM TESTED	11
2.4 DESCRIPTION OF SUPPORT UNITS(CONDUCTED MODE)	13
2.5 EQUIPMENTS LIST FOR ALL TEST ITEMS	14
<b>3 . EMC EMISSION TEST</b>	<b>15</b>
3.1 CONDUCTED EMISSION MEASUREMENT	15
3.1.1 POWER LINE CONDUCTED EMISSION LIMITS	15
3.1.2 TEST PROCEDURE	16
3.1.3 DEVIATION FROM TEST STANDARD	16
3.1.4 TEST SETUP	16
3.1.5 EUT OPERATING CONDITIONS	16
3.1.6 TEST RESULTS	17
3.2 RADIATED EMISSION MEASUREMENT	21
3.2.1 RADIATED EMISSION LIMITS	21
3.2.2 TEST PROCEDURE	22
3.2.3 DEVIATION FROM TEST STANDARD	22
3.2.4 TEST SETUP	23
3.2.5 EUT OPERATING CONDITIONS	24
3.2.6 TEST RESULTS (BETWEEN 9KHZ – 30 MHZ)	25
3.2.7 TEST RESULTS (BETWEEN 30MHZ – 1GHZ)	26
3.2.8 TEST RESULTS (ABOVE 1000 MHZ)	28
<b>4 . POWER SPECTRAL DENSITY TEST</b>	<b>30</b>
4.1 APPLIED PROCEDURES / LIMIT	30
4.1.1 TEST PROCEDURE	30
4.1.2 DEVIATION FROM STANDARD	30
4.1.3 TEST SETUP	30
4.1.4 EUT OPERATION CONDITIONS	31
4.1.5 TEST RESULTS	32
<b>5 . 6DB BANDWIDTH TEST</b>	<b>38</b>
5.1 APPLIED PROCEDURES / LIMIT	38
5.1.1 TEST PROCEDURE	38
TEST SETUP	38

**Table of Contents**

	<b>Page</b>
5.1.2 EUT OPERATION CONDITIONS	38
5.1.3 TEST RESULTS	39
<b>6. 20DB BANDWIDTH</b>	<b>45</b>
6.1 APPLICABLE STANDARD	45
6.1.1 CONFORMANCE LIMIT	45
6.1.2 MEASURING INSTRUMENTS	45
6.1.3 TEST SETUP	45
6.1.4 TEST PROCEDURE	45
6.2 TEST RESULTS	46
<b>7. DUTY CYCLE</b>	<b>51</b>
7.1 APPLICABLE STANDARD	51
7.1.1 CONFORMANCE LIMIT	51
7.1.2 MEASURING INSTRUMENTS	51
7.1.3 TEST SETUP	51
7.1.4 TEST PROCEDURE	51
7.2 TEST RESULTS	52
<b>8. MAXIMUM OUTPUT POWER TEST</b>	<b>54</b>
8.1 APPLIED PROCEDURES / LIMIT	54
8.1.1 TEST PROCEDURE	54
8.1.2 DEVIATION FROM STANDARD	55
8.1.3 TEST SETUP	55
8.1.4 EUT OPERATION CONDITIONS	55
8.2 TEST RESULTS	56
<b>9. 100 KHZ BANDWIDTH OF FREQUENCY BAND EDGE</b>	<b>62</b>
9.1.1 CONFORMANCE LIMIT	62
9.1.2 MEASURING INSTRUMENTS	62
9.1.3 MARKER-DELTA METHOD	62
9.1.4 INTEGRATION METHOD	62
9.1.5 TEST PROCEDURE	62
9.1.6 DEVIATION FROM STANDARD	63
9.1.7 TEST SETUP	63
9.1.8 EUT OPERATION CONDITIONS	63
9.2 TEST RESULTS	64
<b>10. ANTENNA REQUIREMENT</b>	<b>68</b>
10.1 STANDARD REQUIREMENT	68
10.2 EUT ANTENNA	68
<b>11. EUT TEST PHOTO</b>	<b>69</b>

**Table of Contents**

**Page**

**APPENDIX-PHOTOGRAPHS OF EUT CONSTRUCTIONAL DETAILS**

### 1. SUMMARY OF TEST RESULTS

Test procedures according to the technical standards:

FCC Part15 (15.247) , Subpart C			
Standard Section	Test Item	Judgment	Remark
15.207	Conducted Emission	PASS	
15.247 (a)(2)	6dB Bandwidth	PASS	
15.247 (b)	Peak Output Power	PASS	
15.247 (c)	Radiated Spurious Emission	PASS	
15.247 (d)	Power Spectral Density	PASS	
15.205	Band Edge Emission	PASS	
15.203	Antenna Requirement	PASS	

**NOTE:**

(1) "N/A" denotes test is not applicable in this Test Report

### 1.1 TEST FACILITY

NTEK Testing Technology Co., Ltd

Add.:1/F, Building E, Fenda Science Park, Sanwei Community, Xixiang Street, Bao'an District, Shenzhen P.R. China.

FCC Registration No.:238937; IC Registration No.:9270A-1

CNAS Registration No.:L5516

### 1.2 MEASUREMENT UNCERTAINTY

The reported uncertainty of measurement  $y \pm U$ , where expanded uncertainty  $U$  is based on a standard uncertainty multiplied by a coverage factor of  $k=2$ , providing a level of confidence of approximately **95 %**.

No.	Item	Uncertainty
1	Conducted Emission Test	$\pm 1.38\text{dB}$
2	RF power,conducted	$\pm 0.16\text{dB}$
3	Spurious emissions,conducted	$\pm 0.21\text{dB}$
4	All emissions,radiated(<1G)	$\pm 4.68\text{dB}$
5	All emissions,radiated(>1G)	$\pm 4.89\text{dB}$
6	Temperature	$\pm 0.5^\circ\text{C}$
7	Humidity	$\pm 2\%$

## 2. GENERAL INFORMATION

### 2.1 GENERAL DESCRIPTION OF EUT

Equipment	Alpha Intelligent Robot 2	
Trade Name	UBTECH	
Model Name	Alpha 2	
Serial Model	N/A	
Model Difference	N/A	
Product Description	Operation Frequency:	802.11b/g/n(20MHz): 2412~2462MHz
	Modulation Type:	IEEE 802.11b : DSSS (CCK, QPSK, DBPSK) IEEE 802.11g/n (HT20) : OFDM (64QAM, 16QAM, QPSK, BPSK)
	Bit Rate of Transmitter	802.11b:11/5.5/2/1 Mbps 802.11g:54/48/36/24/18/12/9/6Mbps 802.11n(20MHz):150/144.44/130/117/ 115.56/104/86.67/78/52/6.5Mbps
	Number Of Channel	802.11b/g/n20MHz:11CH
	Antenna Designation:	Please see Note 3.
	Antenna Gain (dBi)	1.84 dBi
	Channel List	Please refer to the Note 2.
Ratings	DC 11.1V	
Adapter	Model:WT1403000 Input: AC100-240V~, 50/60Hz,1.6A Output: 14V ---, 3.0A	
Battery	DC 11.1V, 2150mAh	
Connecting I/O Port(s)	Please refer to the User's Manual	



Note:

1. For a more detailed features description, please refer to the manufacturer's specifications or the User's Manual.

2.

Channel List for 802.11b/g/n(20 MHz)							
Channel	Frequency (MHz)	Channel	Frequency (MHz)	Channel	Frequency (MHz)	Channel	Frequency (MHz)
01	2412	04	2427	07	2442	10	2457
02	2417	05	2432	08	2447	11	2462
03	2422	06	2437	09	2452		

3.

Table for Filed Antenna

Ant	Brand	Model Name	Antenna Type	Connector	Gain (dBi)	NOTE
A	N/A	N/A	FPCB Antenna	N/A	1.84	Wifi Antenna

## 2.2 DESCRIPTION OF TEST MODES

To investigate the maximum EMI emission characteristics generates from EUT, the test system was pre-scanning tested base on the consideration of following EUT operation mode or test configuration mode which possible have effect on EMI emission level. Each of these EUT operation mode(s) or test configuration mode(s) mentioned above was evaluated respectively.

Pretest Mode	Description
Mode 1	802.11b CH1/ CH6/ CH11
Mode 2	802.11g CH1/ CH6/ CH11
Mode 3	802.11n20 CH1/ CH6/ CH11
Mode 4	Link Mode

For Conducted Emission	
Final Test Mode	Description
Mode 4	Link Mode

Pretest Mode	Description
Mode 1	802.11b CH1/ CH6/ CH11
Mode 2	802.11g CH1/ CH6/ CH11
Mode 3	802.11n20 CH1/ CH6/ CH11
Mode 4	Link Mode

Note:

- (1) The measurements are performed at the highest, middle, lowest available channels.
- (2) EUT configured to transmit continuously:
- (3) The measurements are performed at all Bit Rate of Transmitter, the worst data was reported

Mode	Data Rate
IEEE 802.11b	1 Mbps
IEEE 802.11g	6 Mbps
IEEE 802.11n20	MCS 7

Operated Mode for Worst Duty Cycle	
Test Signal Duty Cycle (x)	Average correction factor (dB)
100% - IEEE 802.11b	0
100% - IEEE 802.11g	0
100% - IEEE 802.11n (HT20)	0

### 2.3 BLOCK DIGRAM SHOWING THE CONFIGURATION OF SYSTEM TESTED

Conducted Emission Test 1

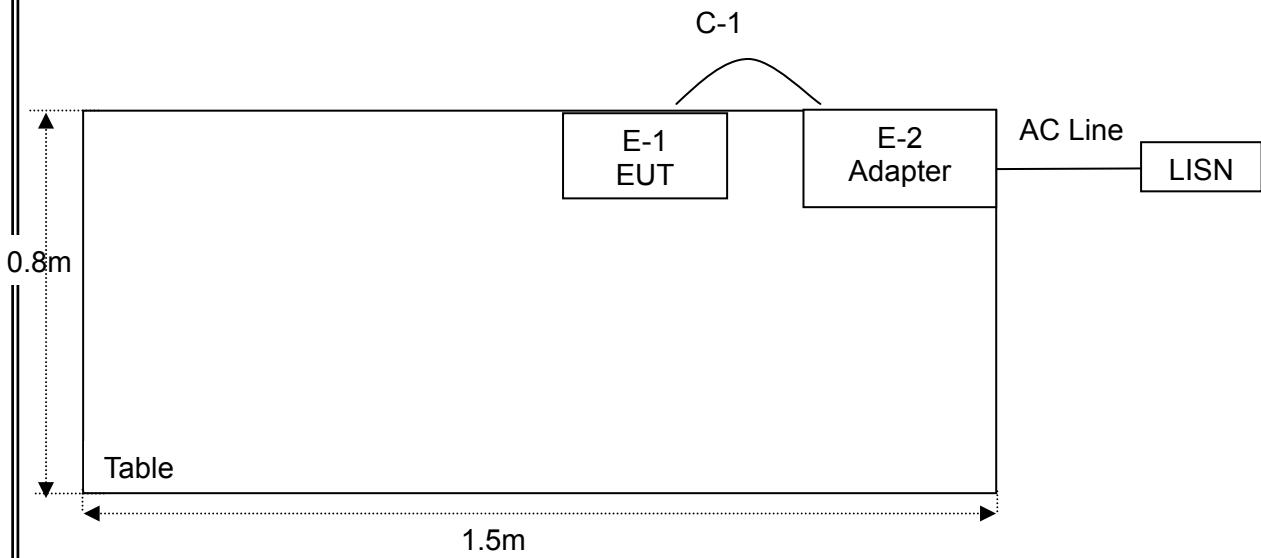

Radiated Spurious Emission Test

E-1  
EUT

**2.4 DESCRIPTION OF SUPPORT UNITS(CONDUCTED MODE)**

The EUT has been tested as an independent unit together with other necessary accessories or support units. The following support units or accessories were used to form a representative test configuration during the tests.

Item	Equipment	Brand	Model/Type No.	Series No.	Note
E-1	Alpha Intelligent Robot 2	UBTECH	Alpha 2	N/A	EUT
E-2	ADAPTER	N/A	WT1403000	N/A	

Item	Shielded Type	Ferrite Core	Length	Note
C-1	Power line	YES	1.2m	

Note:

- (1) The support equipment was authorized by Declaration of Confirmation.
- (2) For detachable type I/O cable should be specified the length in cm in 『Length』 column.

### 2.5 EQUIPMENTS LIST FOR ALL TEST ITEMS

#### Radiation Test equipment

Item	Kind of Equipment	Manufacturer	Type No.	Serial No.	Last calibration	Calibrated until	Calibration period
1	Spectrum Analyzer	Agilent	E4407B	MY45108040	2015.07.06	2016.07.05	1 year
2	Test Receiver	R&S	ESPI	101318	2015.06.06	2016.06.05	1 year
3	Bilog Antenna	TESEQ	CBL6111D	31216	2015.07.06	2016.07.05	1 year
4	50Ω Coaxial Switch	Anritsu	MP59B	6200264416	2015.06.06	2016.06.05	1 year
5	Spectrum Analyzer	ADVANTEST	R3132	150900201	2015.06.06	2016.06.05	1 year
6	Horn Antenna	EM	EM-AH-10180	2011071402	2015.07.06	2016.07.05	1 year
7	Horn Ant	Schwarzbeck	BBHA 9170	9170-181	2015.07.06	2016.07.05	1 year
8	Amplifier	EM	EM-30180	060538	2015.12.22	2016.12.21	1 year
9	Loop Antenna	ARA	PLA-1030/B	1029	2015.06.06	2016.06.05	1 year
10	Power Meter	R&S	NRVS	100696	2015.07.06	2016.07.05	1 year
11	Power Sensor	R&S	URV5-Z4	0395.1619.05	2015.07.06	2016.07.05	1 year

#### Conduction Test equipment

Item	Kind of Equipment	Manufacturer	Type No.	Serial No.	Last calibration	Calibrated until	Calibration period
1	Test Receiver	R&S	ESCI	101160	2015.06.06	2016.06.05	1 year
2	LISN	R&S	ENV216	101313	2015.08.24	2016.08.23	1 year
3	LISN	EMCO	3816/2	00042990	2015.08.24	2016.08.23	1 year
4	50Ω Coaxial Switch	Anritsu	MP59B	6200264417	2015.06.06	2016.06.05	1 year
5	Passive Voltage Probe	R&S	ESH2-Z3	100196	2015.06.06	2016.06.05	1 year
6	Absorbing clamp	R&S	MOS-21	100423	2015.06.06	2016.06.05	1 year

1	Attenuation	MCE	24-10-34	BN9258	2015.07.06	2016.07.05	1 year
---	-------------	-----	----------	--------	------------	------------	--------

### 3. EMC EMISSION TEST

#### 3.1 CONDUCTED EMISSION MEASUREMENT

##### 3.1.1 POWER LINE CONDUCTED EMISSION Limits (Frequency Range 150KHz-30MHz)

FREQUENCY (MHz)	Class A (dBuV)		Class B (dBuV)		Standard
	Quasi-peak	Average	Quasi-peak	Average	
0.15 -0.5	79.00	66.00	66 - 56 *	56 - 46 *	CISPR
0.50 -5.0	73.00	60.00	56.00	46.00	CISPR
5.0 -30.0	73.00	60.00	60.00	50.00	CISPR

0.15 -0.5	79.00	66.00	66 - 56 *	56 - 46 *	FCC
0.50 -5.0	73.00	60.00	56.00	46.00	FCC
5.0 -30.0	73.00	60.00	60.00	50.00	FCC

Note:

- (1) The tighter limit applies at the band edges.
- (2) The limit of " \* " marked band means the limitation decreases linearly with the logarithm of the frequency in the range.

The following table is the setting of the receiver

Receiver Parameters	Setting
Attenuation	10 dB
Start Frequency	0.15 MHz
Stop Frequency	30 MHz
IF Bandwidth	9 kHz

### 3.1.2 TEST PROCEDURE

- a. The EUT was placed 0.8 meters from the horizontal ground plane with EUT being connected to the power mains through a line impedance stabilization network (LISN). All other support equipments powered from additional LISN(s). The LISN provide 50 Ohm/ 50uH of coupling impedance for the measuring instrument.
- b. Interconnecting cables that hang closer than 40 cm to the ground plane shall be folded back and forth in the center forming a bundle 30 to 40 cm long.
- c. I/O cables that are not connected to a peripheral shall be bundled in the center. The end of the cable may be terminated, if required, using the correct terminating impedance. The overall length shall not exceed 1 m.
- d. LISN at least 80 cm from nearest part of EUT chassis.
- e. For the actual test configuration, please refer to the related Item –EUT Test Photos.

### 3.1.3 DEVIATION FROM TEST STANDARD

No deviation

### 3.1.4 TEST SETUP

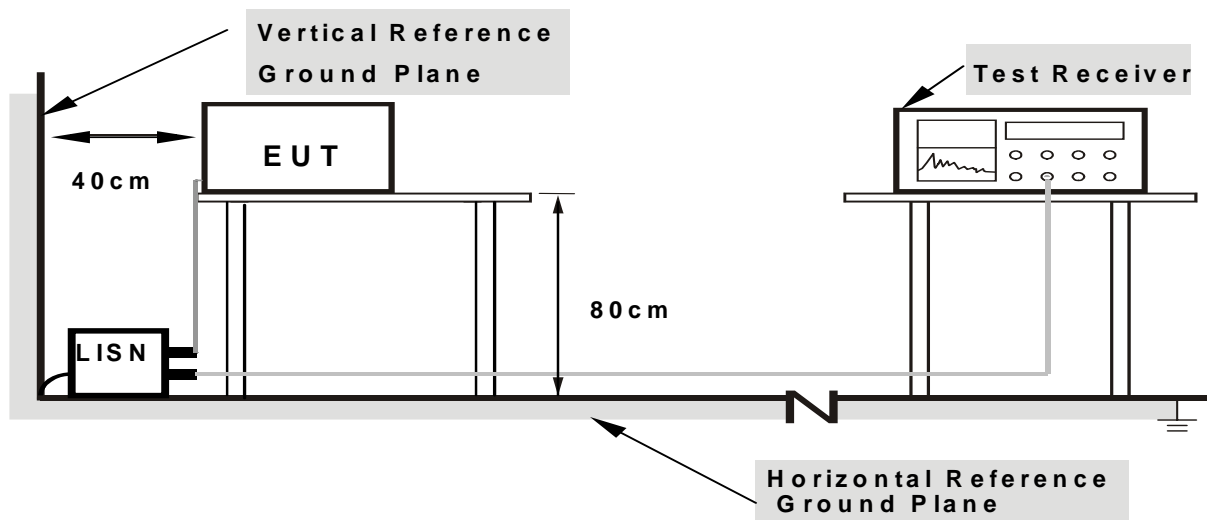

**Note: 1. Support units were connected to second LISN.**

**2. Both of LISNs (AMN) are 80 cm from EUT and at least 80 cm from other units and other metal planes**

### 3.1.5 EUT OPERATING CONDITIONS

The EUT was configured for testing in a typical fashion (as a customer would normally use it). The EUT has been programmed to continuously transmit during test. This operating condition was tested and used to collect the included data.



### 3.1.6 TEST RESULTS

EUT :	Alpha Intelligent Robot 2	Model Name :	Alpha 2
Temperature :	26 °C	Relative Humidity :	54%
Pressure :	1010hPa	Phase :	L
Test Voltage :	DC 14V form Adapter AC 120V/60Hz	Test Mode :	Mode 4

Frequency (MHz)	Reading Level (dBμV)	Correct Factor (dB)	Measure-ment (dBμV)	Limits (dBμV)	Margin (dB)	Remark
0.1580	49.06	10.12	59.18	65.56	-6.38	QP
0.1580	31.33	10.12	41.45	55.56	-14.11	AVG
0.2300	38.56	10.13	48.69	62.45	-13.76	QP
0.2300	22.11	10.13	32.24	52.45	-20.21	AVG
0.6860	25.22	9.78	35.00	56.00	-21.00	QP
0.6860	15.27	9.78	25.05	46.00	-20.95	AVG
3.2940	27.75	9.74	37.49	56.00	-18.51	QP
3.2940	18.86	9.74	28.60	46.00	-17.40	AVG
4.4218	32.66	9.75	42.41	56.00	-13.59	QP
4.4218	21.99	9.75	31.74	46.00	-14.26	AVG
9.2179	25.14	9.78	34.92	60.00	-25.08	QP
9.2179	17.56	9.78	27.34	50.00	-22.66	AVG

Remark:  
 1. All readings are Quasi-Peak and Average values.  
 2. Factor = Insertion Loss + Cable Loss.

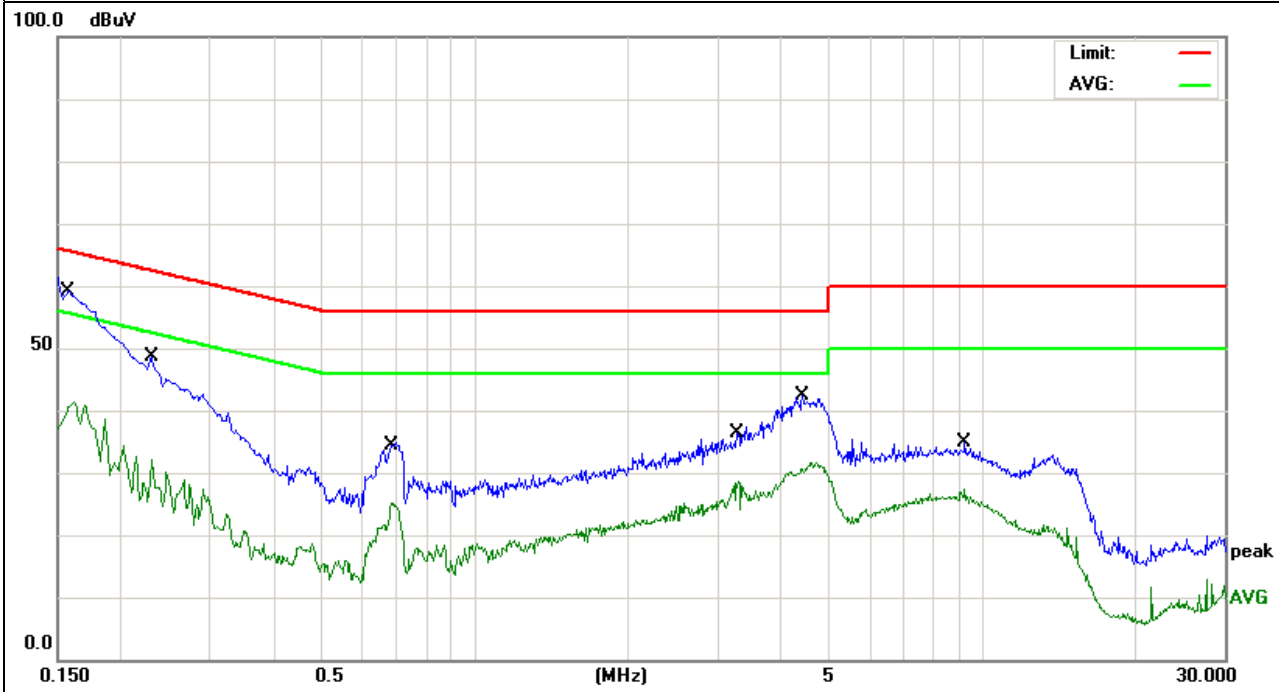

EUT :	Alpha Intelligent Robot 2	Model Name :	Alpha 2
Temperature :	26 °C	Relative Humidity :	54%
Pressure :	1010hPa	Phase :	N
Test Voltage :	DC 14V form Adapter AC 120V/60Hz	Test Mode :	Mode 4

Frequency (MHz)	Reading Level (dBμV)	Correct Factor (dB)	Measure-ment (dBμV)	Limits (dBμV)	Margin (dB)	Remark
0.1580	47.64	10.12	57.76	65.56	-7.80	QP
0.1580	30.34	10.12	40.46	55.56	-15.10	AVG
0.2059	40.80	10.13	50.93	63.37	-12.44	QP
0.2059	23.65	10.13	33.78	53.37	-19.59	AVG
0.6860	25.32	9.78	35.10	56.00	-20.90	QP
0.6860	15.38	9.78	25.16	46.00	-20.84	AVG
3.2620	26.77	9.74	36.51	56.00	-19.49	QP
3.2620	19.18	9.74	28.92	46.00	-17.08	AVG
4.5458	32.72	9.75	42.47	56.00	-13.53	QP
4.5458	22.76	9.75	32.51	46.00	-13.49	AVG
9.0978	24.91	9.78	34.69	60.00	-25.31	QP
9.0978	17.67	9.78	27.45	50.00	-22.55	AVG

Remark:

1. All readings are Quasi-Peak and Average values.
2. Factor = Insertion Loss + Cable Loss.

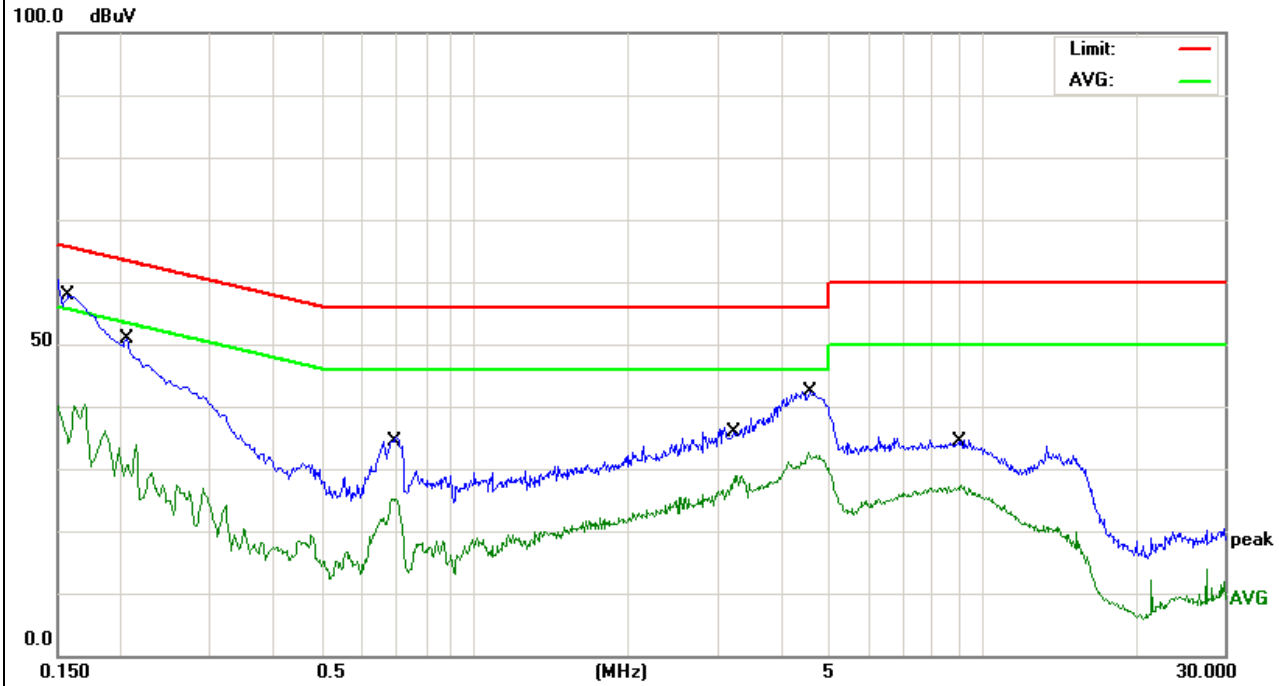

EUT :	Alpha Intelligent Robot 2	Model Name :	Alpha 2
Temperature :	26 °C	Relative Humidity :	54%
Pressure :	1010hPa	Phase :	L
Test Voltage :	DC 14V form Adapter AC 240V/60Hz	Test Mode :	Mode 4

Frequency (MHz)	Reading Level (dBμV)	Correct Factor (dB)	Measure-ment (dBμV)	Limits (dBμV)	Margin (dB)	Remark
0.1580	51.97	10.12	62.09	65.56	-3.47	QP
0.1580	31.77	10.12	41.89	55.56	-13.67	AVG
0.3220	35.84	10.12	45.96	59.65	-13.69	QP
0.3220	29.15	10.12	39.27	49.65	-10.38	AVG
0.9659	32.74	9.84	42.58	56.00	-13.42	QP
0.9659	30.22	9.84	40.06	46.00	-5.94	AVG
1.6100	32.82	9.78	42.60	56.00	-13.40	QP
1.6100	30.25	9.78	40.03	46.00	-5.97	AVG
2.9020	34.26	9.74	44.00	56.00	-12.00	QP
2.9020	30.98	9.74	40.72	46.00	-5.28	AVG
4.1898	34.95	9.75	44.70	56.00	-11.30	QP
4.1898	29.53	9.75	39.28	46.00	-6.72	AVG

Remark:

1. All readings are Quasi-Peak and Average values.
2. Factor = Insertion Loss + Cable Loss.

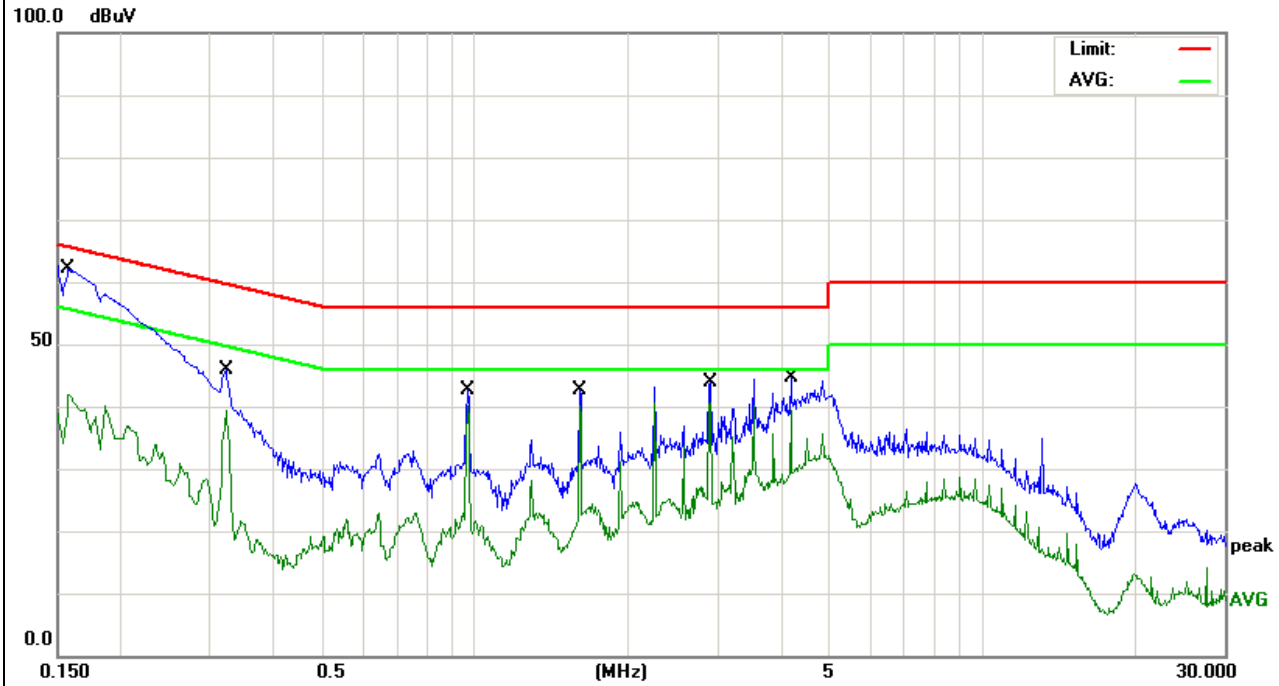

EUT :	Alpha Intelligent Robot 2	Model Name :	Alpha 2
Temperature :	26 °C	Relative Humidity :	54%
Pressure :	1010hPa	Phase :	N
Test Voltage :	DC 14V form Adapter AC 240V/60Hz	Test Mode :	Mode 4

Frequency (MHz)	Reading Level (dBμV)	Correct Factor (dB)	Measure-ment (dBμV)	Limits (dBμV)	Margin (dB)	Remark
0.1580	51.45	10.12	61.57	65.56	-3.99	QP
0.1580	33.40	10.12	43.52	55.56	-12.04	AVG
0.3220	35.17	10.12	45.29	59.65	-14.36	QP
0.3220	28.87	10.12	38.99	49.65	-10.66	AVG
0.9658	32.70	9.84	42.54	56.00	-13.46	QP
0.9658	30.20	9.84	40.04	46.00	-5.96	AVG
1.6100	32.21	9.78	41.99	56.00	-14.01	QP
1.6100	30.09	9.78	39.87	46.00	-6.13	AVG
2.9020	33.84	9.74	43.58	56.00	-12.42	QP
2.9020	30.94	9.74	40.68	46.00	-5.32	AVG
4.1897	39.22	9.75	48.97	56.00	-7.03	QP
4.1897	34.95	9.75	44.70	46.00	-1.30	AVG

Remark:

1. All readings are Quasi-Peak and Average values.
2. Factor = Insertion Loss + Cable Loss.

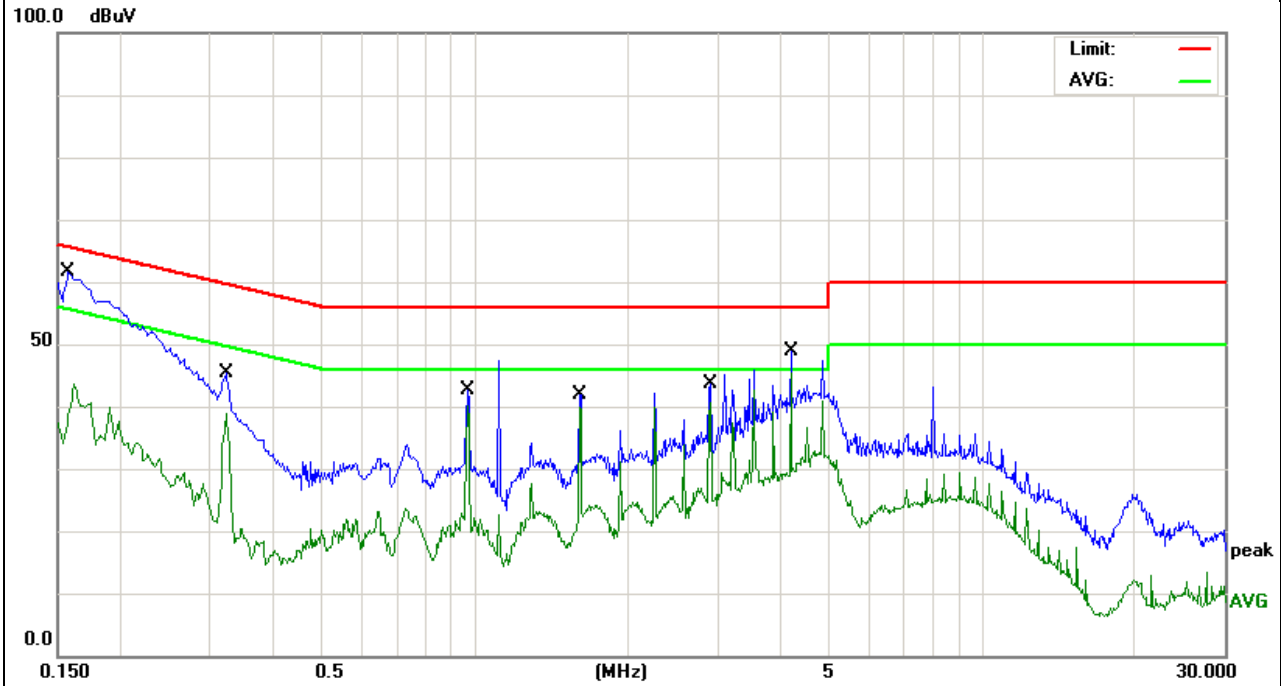

### 3.2 RADIATED EMISSION MEASUREMENT

#### 3.2.1 RADIATED EMISSION LIMITS (Frequency Range 9kHz-1000MHz)

20dBc in any 100 kHz bandwidth outside the operating frequency band. In case the emission fall within the restricted band specified on 15.205(a), then the 15.209(a) limit in the table below has to be followed.

Frequencies (MHz)	Field Strength (microrvolts/meter)	Measurement Distance (meters)
0.009~0.490	2400/F(KHz)	300
0.490~1.705	24000/F(KHz)	30
1.705~30.0	30	30
30~88	100	3
88~216	150	3
216~960	200	3
Above 960	500	3

#### LIMITS OF RADIATED EMISSION MEASUREMENT (Above 1000MHz)

FREQUENCY (MHz)	dBuV/m@at 3M	
	PEAK	AVERAGE
Above 1000	74	54

Notes:

- (1) The limit for radiated test was performed according to FCC PART 15C.
- (2) The tighter limit applies at the band edges.
- (3) Emission level (dBuV/m)=20log Emission level (uV/m).

Spectrum Parameter	Setting
Attenuation	Auto
Start Frequency	1000 MHz
Stop Frequency	10th carrier harmonic
RB / VB (emission in restricted band)	1 MHz / 1 MHz for Peak, 1 MHz / 10Hz for Average

Receiver Parameter	Setting
Attenuation	Auto
Start ~ Stop Frequency	9kHz~150kHz / RB 200Hz for QP
Start ~ Stop Frequency	150kHz~30MHz / RB 9kHz for QP
Start ~ Stop Frequency	30MHz~1000MHz / RB 120kHz for QP

**3.2.2 TEST PROCEDURE**

- a. The measuring distance of at 3 m shall be used for measurements at frequency up to 1GHz. For frequencies above 1GHz, any suitable measuring distance may be used.
- b. The EUT was placed on the top of a rotating table 0.8 m for below 1GHz and 1.5m for above 1GHz the ground at a 3 meter. The table was rotated 360 degrees to determine the position of the highest radiation.
- c. The height of the equipment or of the substitution antenna shall be 0.8 m for below 1GHz and 1.5m for above 1GHz; the height of the test antenna shall vary between 1 m to 4 m. Both horizontal and vertical polarizations of the antenna are set to make the measurement.
- d. The initial step in collecting conducted emission data is a spectrum analyzer peak detector mode pre-scanning the measurement frequency range. Significant peaks are then marked and then Quasi Peak detector mode re-measured.
- e. If the Peak Mode measured value compliance with and lower than Quasi Peak Mode Limit, the EUT shall be deemed to meet QP Limits and then no additional QP Mode measurement performed.
- f. For the actual test configuration, please refer to the related Item –EUT Test Photos.

Note:

Both horizontal and vertical antenna polarities were tested and performed pretest to three orthogonal axis. The worst case emissions were reported

During the radiated emission test, the Spectrum Analyzer was set with the following configurations:

Frequency Band (MHz)	Function	Resolution bandwidth	Video Bandwidth
30 to 1000	Peak	100 kHz	100 kHz
Above 1000	Peak	1 MHz	1 MHz
	Average	1 MHz	10 Hz

**3.2.3 DEVIATION FROM TEST STANDARD**

No deviation

**3.2.4 TEST SETUP**

(A) Radiated Emission Test-Up Frequency Below 30MHz

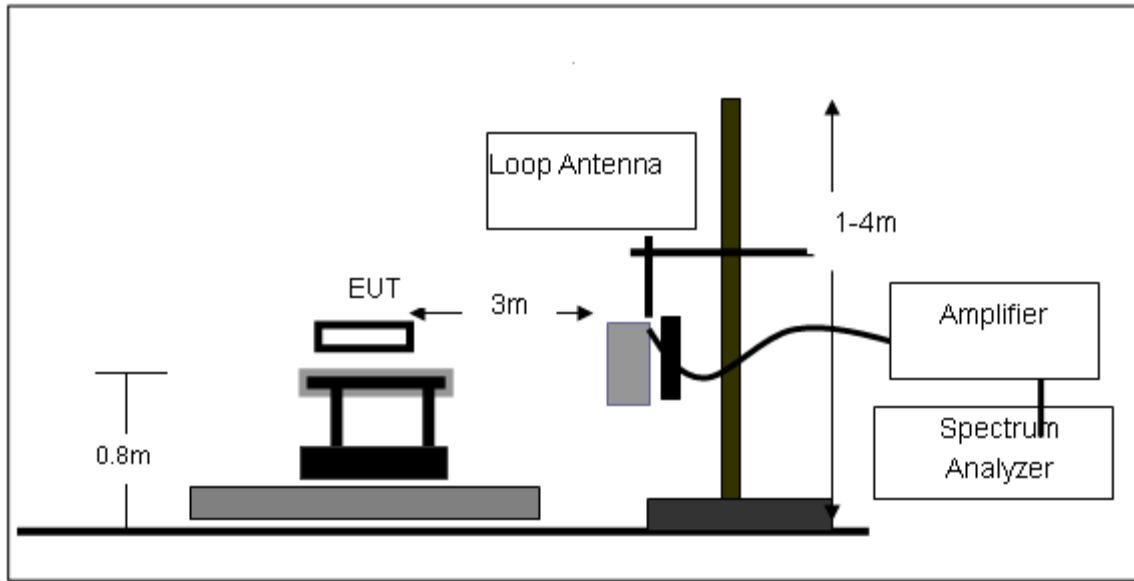

(B) Radiated Emission Test-Up Frequency 30MHz~1GHz

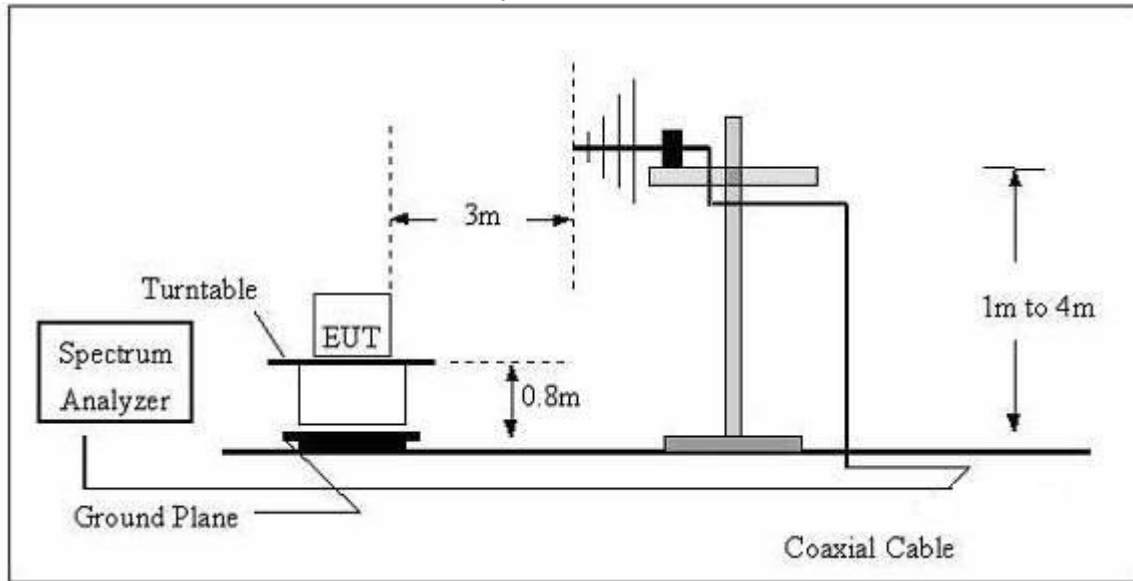

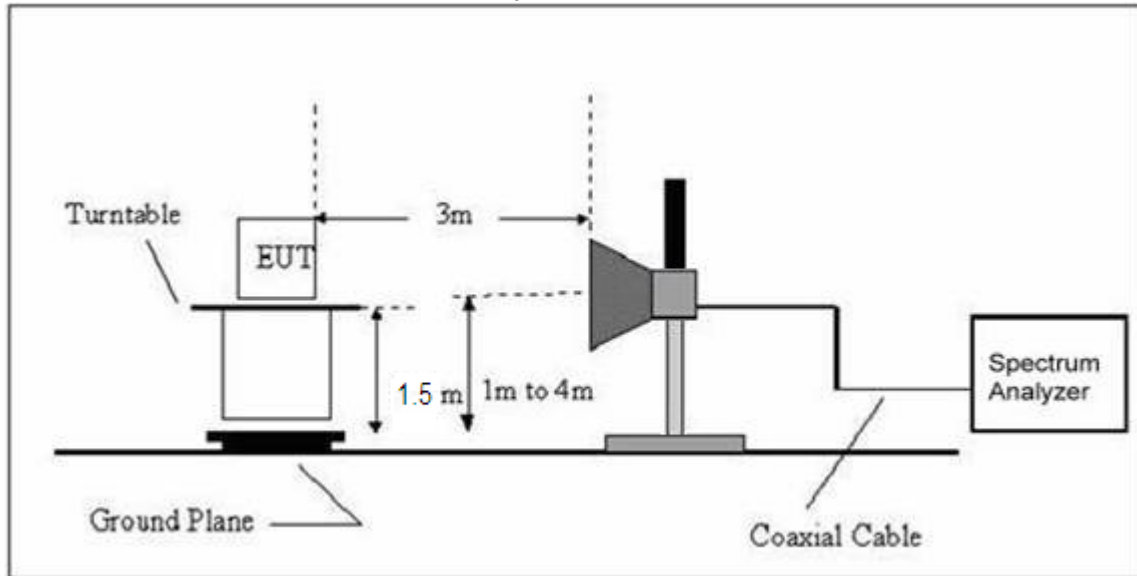
**(C) Radiated Emission Test-Up Frequency Above 1GHz****3.2.5 EUT OPERATING CONDITIONS**

The EUT tested system was configured as the statements of 2.4 Unless otherwise a special operating condition is specified in the follows during the testing.



**3.2.6 TEST RESULTS (BETWEEN 9KHZ – 30 MHZ)**

EUT:	Alpha Intelligent Robot 2	Model Name. :	Alpha 2
Temperature:	20 °C	Relative Humidity:	48%
Pressure:	1010 hPa	Test Voltage :	DC 11.1V
Test Mode :	TX	Polarization :	--

Freq.	Reading	Limit	Margin	State
(MHz)	(dBuV/m)	(dBuV/m)	(dB)	P/F
--	--	--	--	N/A
--	--	--	--	N/A

**NOTE:**

The amplitude of spurious emissions which are attenuated by more than 20dB below the permissible value has no need to be reported.

Distance extrapolation factor =  $40 \log (\text{specific distance}/\text{test distance})$ (dB);

Limit line = specific limits(dBuv) + distance extrapolation factor.

### 3.2.7 TEST RESULTS (BETWEEN 30MHZ – 1GHZ)

EUT :	Alpha Intelligent Robot 2	Model Name :	Alpha 2
Temperature :	20 °C	Relative Humidity :	48%
Pressure :	1010 hPa	Test Voltage :	DC 11.1V
Test Mode :	TX -802.11B (High CH)		

Polar (H/V)	Frequency	Meter Reading	Factor	Emission Level	Limits	Margin	Remark
	(MHz)	(dBuV)	(dB)	(dBuV/m)	(dBuV/m)	(dB)	
V	44.2751	22.69	12.38	35.07	40.00	-4.93	QP
V	77.0502	24.32	9.54	33.86	40.00	-6.14	QP
V	141.3298	26.32	11.08	37.40	43.50	-6.10	QP
V	390.7225	23.40	14.76	38.16	46.00	-7.84	QP
V	513.6331	20.05	17.19	37.24	46.00	-8.76	QP
V	833.3170	16.85	23.16	40.01	46.00	-5.99	QP

**Remark:**

Absolute Level= ReadingLevel+ Factor, Margin= Absolute Level - Limit

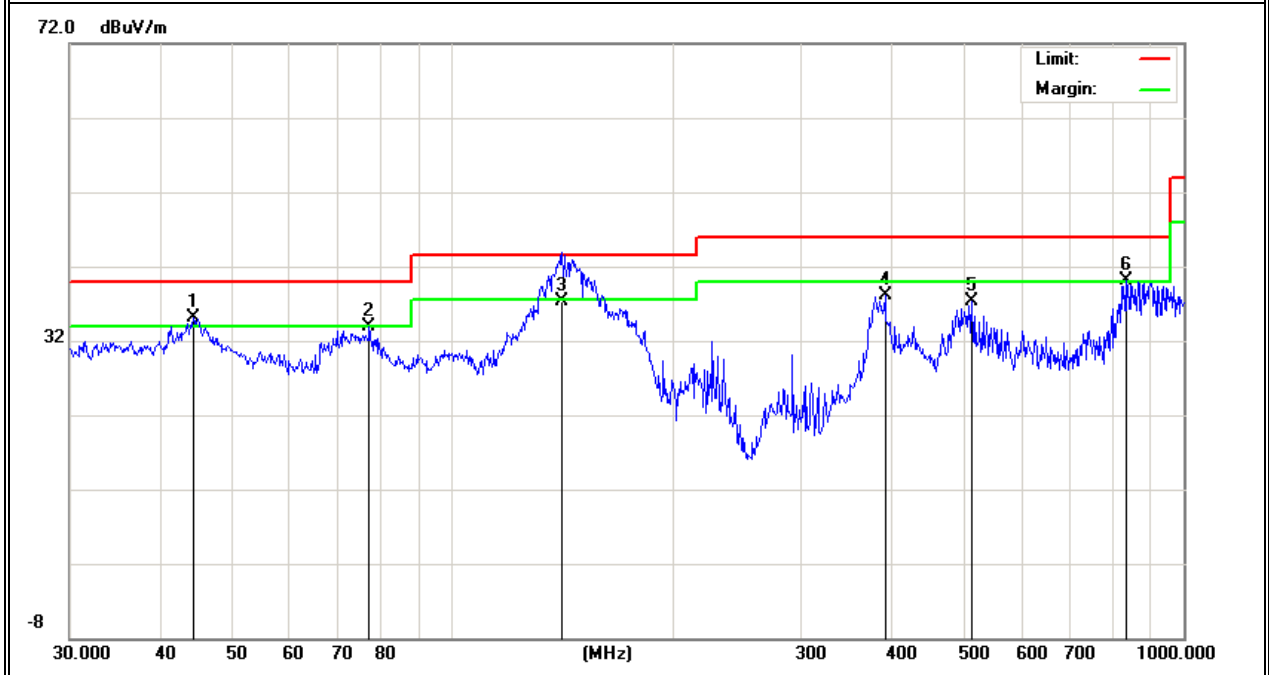

Polar (H/V)	Frequency	Meter Reading	Factor	Emission Level	Limits	Margin	Remark
	(MHz)	(dBuV)	(dB)	(dBuV/m)	(dBuV/m)	(dB)	
H	126.3285	19.79	10.72	30.51	43.50	-12.99	QP
H	168.4138	20.00	12.30	32.30	43.50	-11.20	QP
H	214.5142	24.04	11.04	35.08	43.50	-8.42	QP
H	281.0074	21.56	11.93	33.49	46.00	-12.51	QP
H	663.4728	15.67	20.71	36.38	46.00	-9.62	QP
H	884.5029	17.14	23.75	40.89	46.00	-5.11	QP

**Remark:**

Absolute Level= ReadingLevel+ Factor, Margin= Absolute Level - Limit

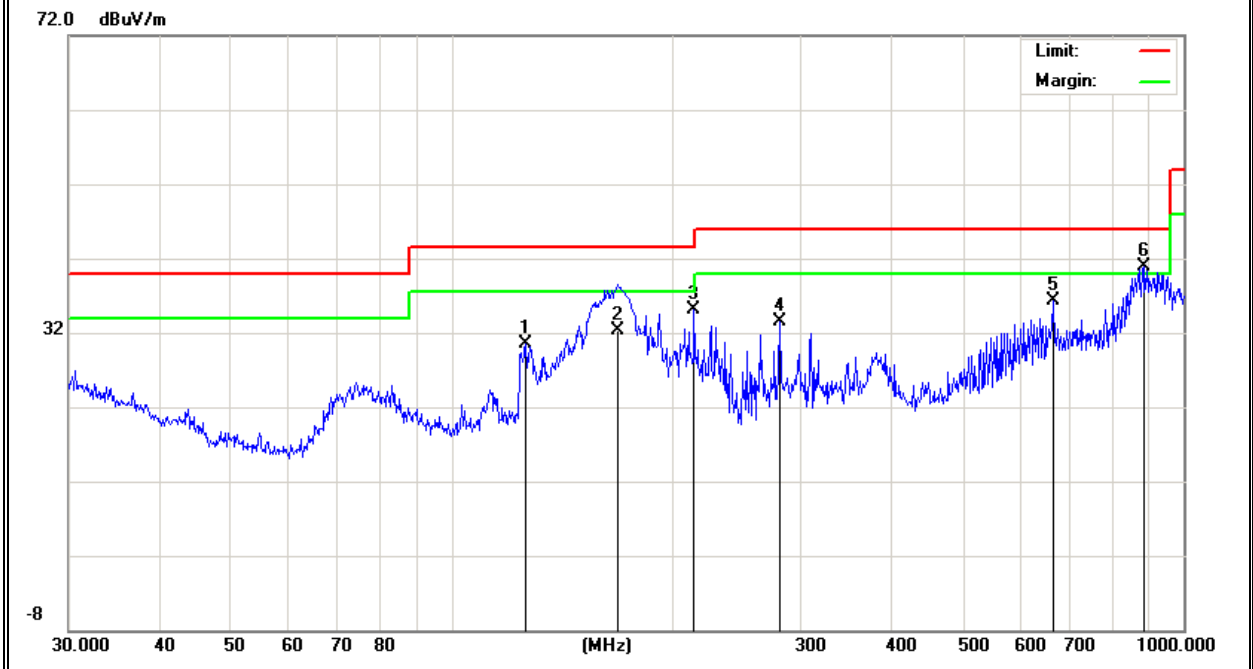

### 3.2.8 TEST RESULTS (ABOVE 1000 MHZ)

EUT :	Alpha Intelligent Robot 2	Model Name :	Alpha 2
Temperature :	20 °C	Relative Humidity :	48%
Pressure :	1010 hPa	Test Voltage :	DC 11.1V
Test Mode :	TX		

Polar (H/V)	Frequency	Meter Reading	Factor	Emission Level	Limits	Margin	Detector Type
	(MHz)	(dBuV)	(dB)	(dBuV/m)	(dBuV/m)	(dB)	
<b>Low Channel (2412 MHz)-Above 1G</b>							
Vertical	4824.148	55.48	10.44	65.92	74.00	-8.08	Pk
Vertical	4824.148	30.15	10.44	40.59	54.00	-13.41	Av
Vertical	7236.201	48.76	12.39	61.15	74.00	-12.85	Pk
Vertical	7236.201	32.26	12.39	44.65	54.00	-9.35	Av
Horizontal	4824.297	49.85	10.44	60.29	74.00	-13.71	Pk
Horizontal	4824.297	30.42	10.44	40.86	54.00	-13.14	Av
Horizontal	7236.233	48.96	12.39	61.35	74.00	-12.65	Pk
Horizontal	7236.233	31.55	12.39	43.94	54.00	-10.06	Av
<b>Mid Channel (2437 MHz)-Above 1G</b>							
Vertical	4874.155	52.34	10.40	62.74	74.00	-11.26	Pk
Vertical	4874.155	33.69	10.40	44.09	54.00	-9.91	Av
Vertical	7311.212	48.81	12.75	61.56	74.00	-12.44	Pk
Vertical	7311.212	29.64	12.75	42.39	54.00	-11.61	Av
Horizontal	4874.199	53.28	10.40	63.68	74.00	-10.32	Pk
Horizontal	4874.199	30.05	10.40	40.45	54.00	-13.55	Av
Horizontal	7311.164	47.84	12.75	60.59	74.00	-13.41	Pk
Horizontal	7311.164	30.21	12.75	42.96	54.00	-11.04	Av
<b>High Channel (2462 MHz)- Above 1G</b>							
Vertical	4924.321	51.47	10.39	61.86	74.00	-12.14	Pk
Vertical	4924.321	29.68	10.39	40.07	54.00	-13.93	Av
Vertical	7386.193	45.62	12.68	58.30	74.00	-15.70	Pk
Vertical	7386.193	30.12	12.68	42.80	54.00	-11.20	Av
Horizontal	4924.142	51.47	10.39	61.86	74.00	-12.14	Pk
Horizontal	4924.142	33.69	10.39	44.08	54.00	-9.92	Av
Horizontal	7386.289	49.74	12.68	62.42	74.00	-11.58	Pk
Horizontal	7386.289	31.25	12.68	43.93	54.00	-10.07	Av

Note: "802.11b" mode is the worst mode.

Radiated band edge:

Frequency (MHz)	Meter Reading (dBμV)	Factor (dB)	Emission Level (dBμV/m)	Limits (dBμV/m)	Margin (dB)	Detector Type	Comment
<b>802.11b</b>							
2390	59.85	-13.06	46.79	74	-27.21	peak	Vertical
2390	58.61	-13.06	45.55	74	-28.45	peak	Horizontal
2483.5	59.74	-12.78	46.96	74	-27.04	peak	Vertical
2483.5	60.13	-12.78	47.35	74	-26.65	peak	Horizontal
<b>802.11g</b>							
2390	59.47	-13.06	46.41	74	-27.59	peak	Vertical
2390	60.24	-13.06	47.18	74	-26.82	peak	Horizontal
2483.5	58.64	-12.78	45.86	74	-28.14	peak	Vertical
2483.5	58.79	-12.78	46.01	74	-27.99	peak	Horizontal
<b>802.11n (20)</b>							
2390	58.86	-13.06	45.8	74	-28.20	peak	Vertical
2390	60.14	-13.06	47.08	74	-26.92	peak	Horizontal
2483.5	59.82	-12.78	47.04	74	-26.96	peak	Vertical
2483.5	59.63	-12.78	46.85	74	-27.15	peak	Horizontal

## 4. POWER SPECTRAL DENSITY TEST

### 4.1 APPLIED PROCEDURES / LIMIT

FCC Part15 (15.247) , Subpart C				
Section	Test Item	Limit	Frequency Range (MHz)	Result
15.247	Power Spectral Density	8 dBm (in any 3KHz)	2400-2483.5	PASS

#### 4.1.1 TEST PROCEDURE

The testing follows Measurement Procedure 10.3 Method AVGPSD of FCC KDB Publication No. 558074 D01 DTS Meas. Guidance v03r04

This procedure may be used when the maximum (average) conducted output power was used to demonstrate compliance to the output power limit. This is the baseline method for determining the maximum (average) conducted PSD level. If the instrument has an RMS power averaging detector, it must be used; otherwise, use the sample detector. The EUT must be configured to transmit continuously (duty cycle  $\geq 98\%$ ); otherwise sweep triggering/signal gating must be implemented to ensure that measurements are made only when the EUT is transmitting at its maximum power control level (no transmitter off time is to be considered).

The RF output of EUT was connected to the spectrum analyzer by RF cable and attenuator.

The path loss was compensated to the results for each measurement.

Set to the maximum power setting and enable the EUT transmit continuously.

The EUT was operating in controlled its channel.

- a) Set instrument center frequency to DTS channel center frequency.
- b) Set span to at least 1.5 times the OBW.
- c) Set RBW to:  $3 \text{ kHz} \leq \text{RBW} \leq 100 \text{ kHz}$ .
- d) Set VBW  $\geq 3 \times \text{RBW}$ .
- e) Detector = power averaging (RMS) or sample detector (when RMS not available).
- f) Ensure that the number of measurement points in the sweep  $\geq 2 \times \text{span}/\text{RBW}$ .
- g) Sweep time = auto couple.
- h) Employ trace averaging (RMS) mode over a minimum of 100 traces.
- i) Use the peak marker function to determine the maximum amplitude level.
- j) If measured value exceeds limit, reduce RBW (no less than 3 kHz) and repeat (note that this may require zooming in on the emission of interest and reduc

#### 4.1.2 DEVIATION FROM STANDARD

No deviation.

#### 4.1.3 TEST SETUP



#### **4.1.4 EUT OPERATION CONDITIONS**

The EUT tested system was configured as the statements of 2.1 Unless otherwise a special operating condition is specified in the follows during the testing.

**4.1.5 TEST RESULTS**

EUT :	Alpha Intelligent Robot 2	Model Name :	Alpha 2
Temperature :	25 °C	Relative Humidity :	56%
Pressure :	1015 hPa	Test Voltage :	DC 11.1V
Test Mode :	TX b Mode /CH01, CH06, CH11		

Frequency	Power Density (dBm/3KHz)	Limit (dBm/3KHz)	Result
2412 MHz	-20.02	8	PASS
2437 MHz	-11.96	8	PASS
2462 MHz	-19.33	8	PASS

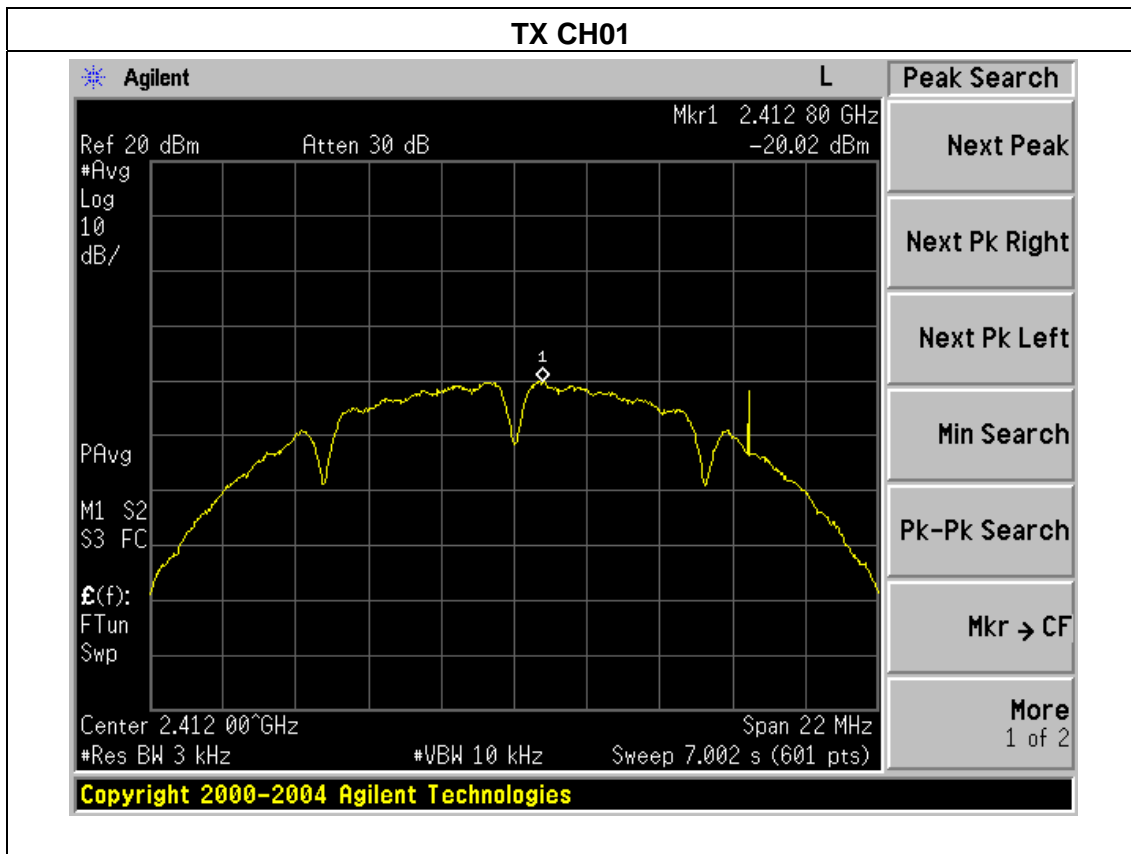



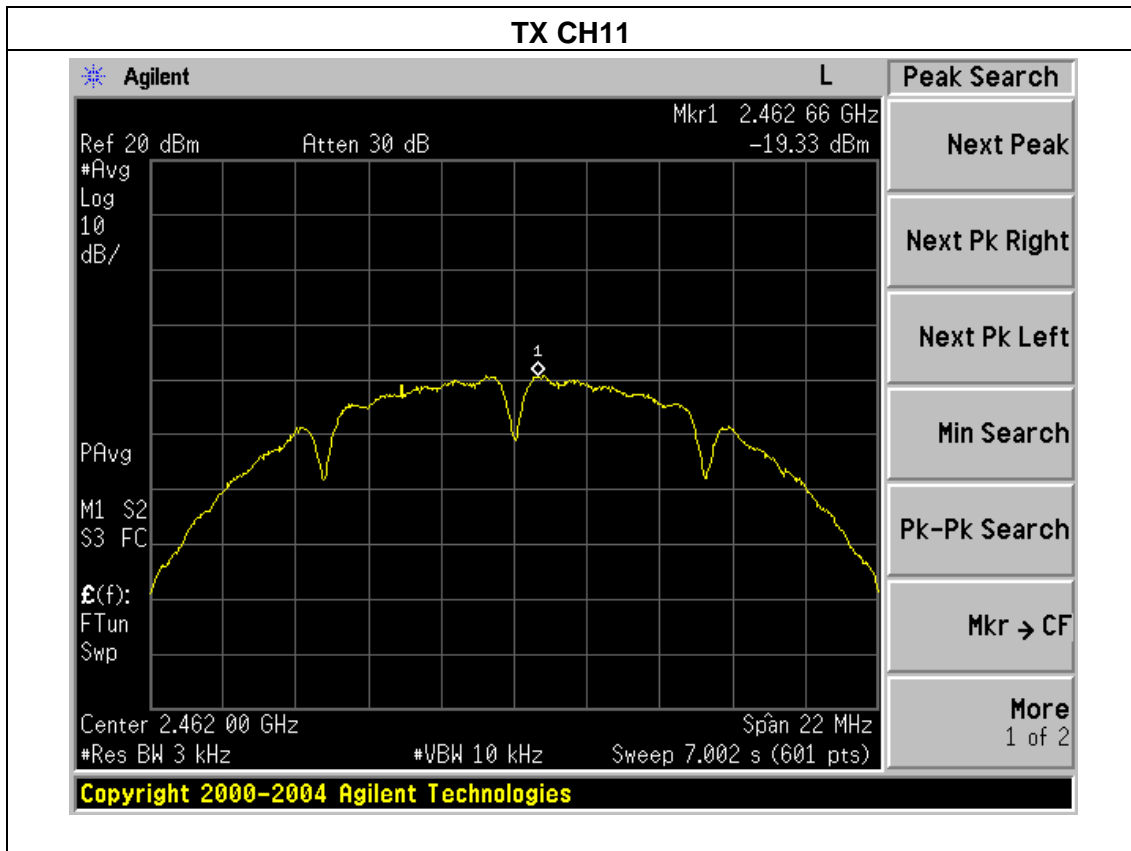
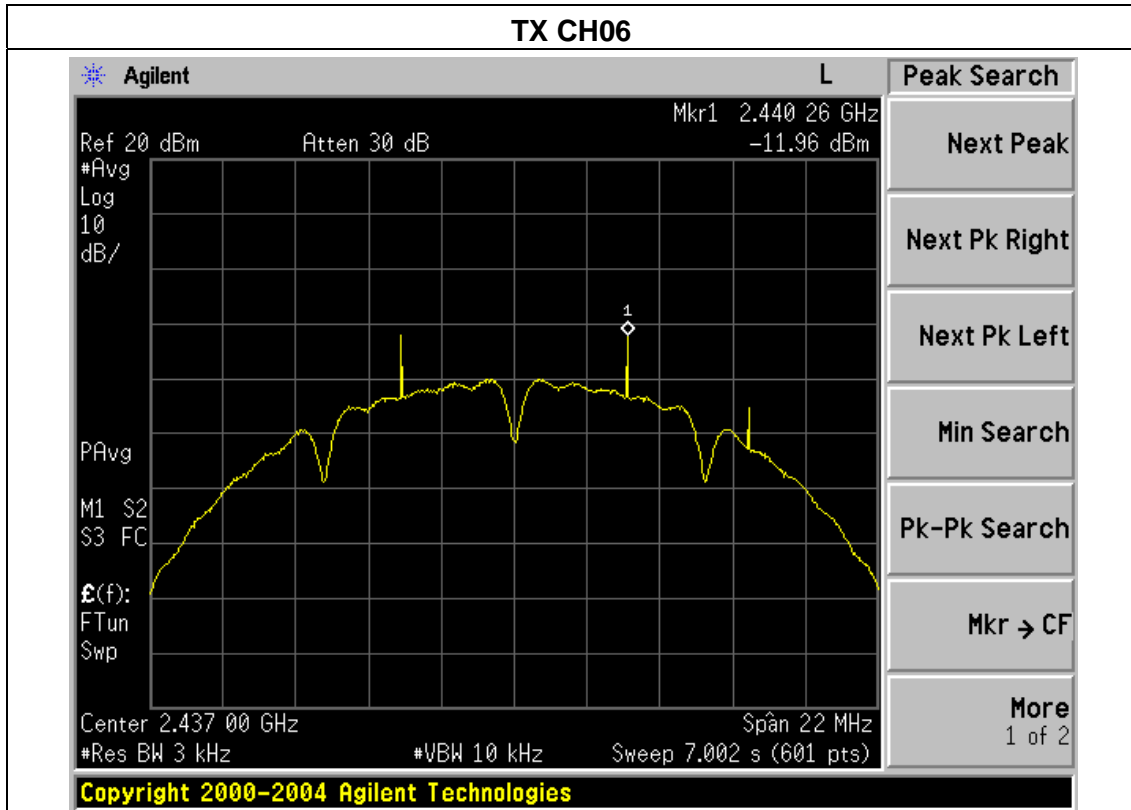

EUT :	Alpha Intelligent Robot 2	Model Name :	Alpha 2
Temperature :	25 °C	Relative Humidity :	56%
Pressure :	1015 hPa	Test Voltage :	DC 11.1V
Test Mode :	TX g Mode /CH01, CH06, CH11		

Frequency	Power Density (dBm/3KHz)	Limit (dBm/3KHz)	Result
2412 MHz	-22.32	8	PASS
2437 MHz	-22.44	8	PASS
2462 MHz	-21.48	8	PASS

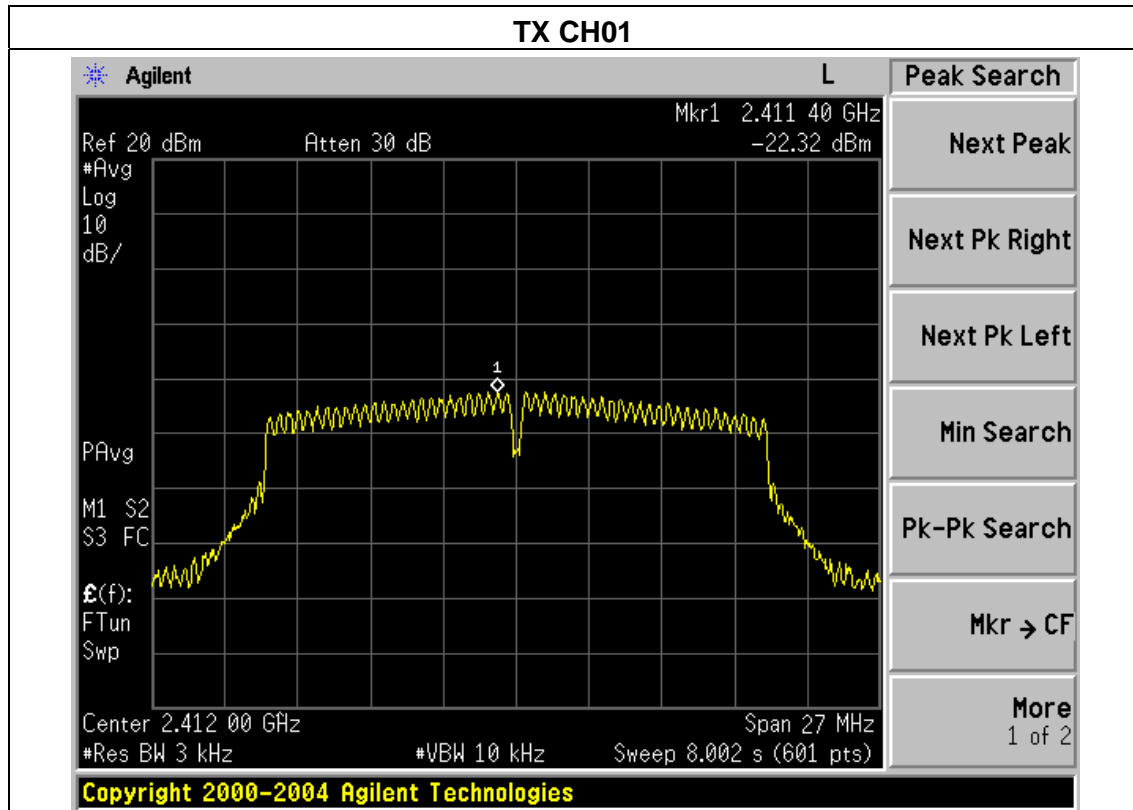

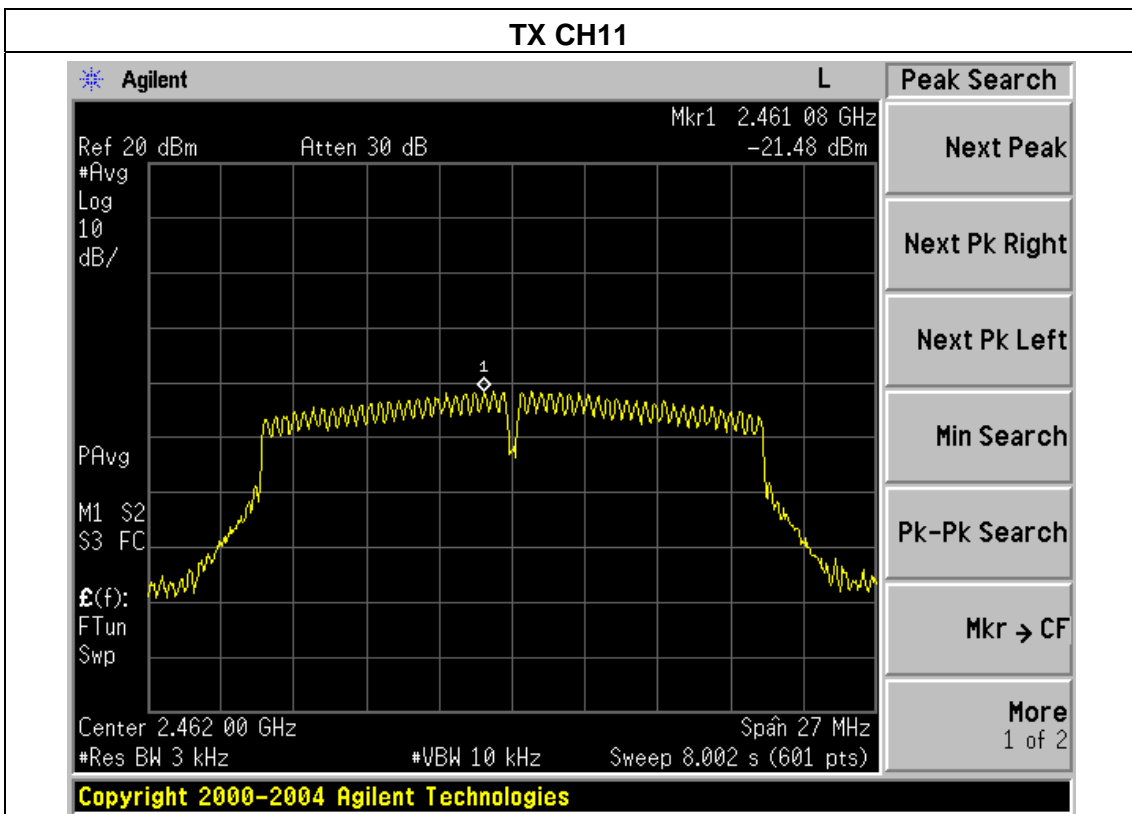
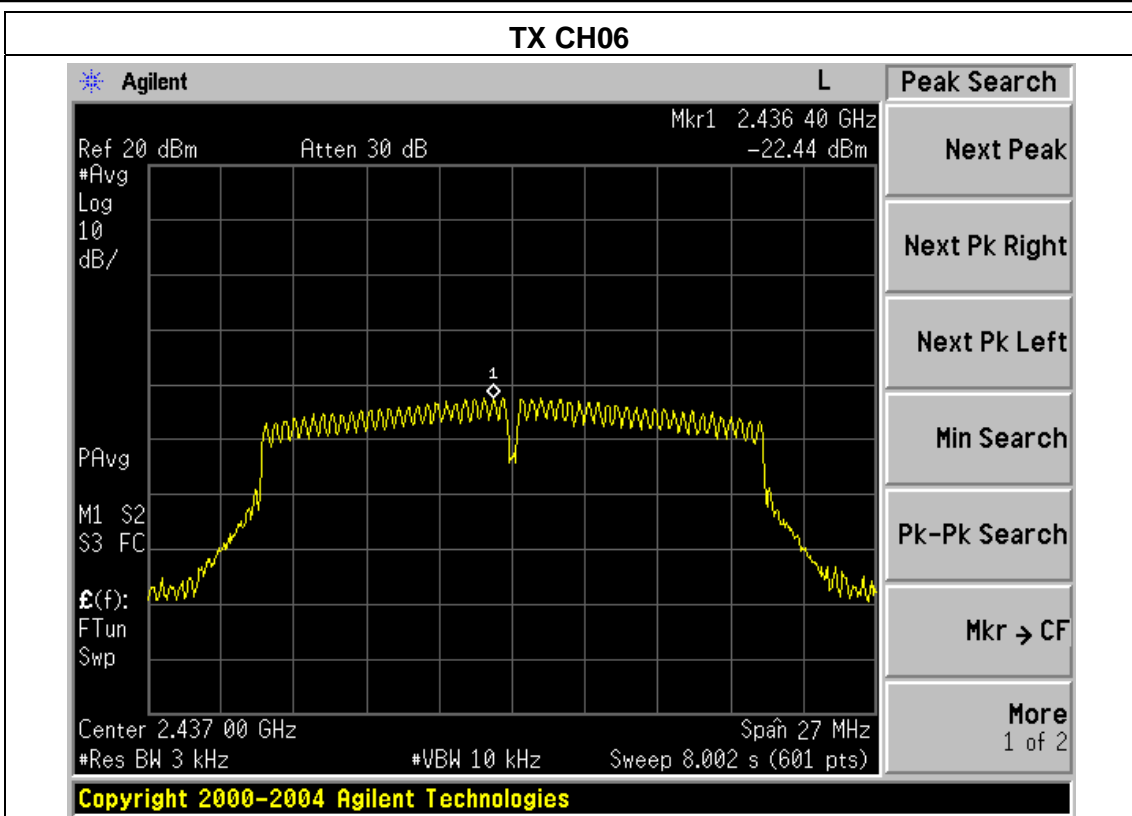

EUT :	Alpha Intelligent Robot 2	Model Name :	Alpha 2
Temperature :	25 °C	Relative Humidity :	56%
Pressure :	1015 hPa	Test Voltage :	DC 11.1V
Test Mode :	TX n Mode (20MHz)/CH01, CH06, CH11		

Frequency	Power Density (dBm/3KHz)	Limit (dBm/3KHz)	Result
2412 MHz	-22.59	8	PASS
2437 MHz	-22.67	8	PASS
2462 MHz	-22.02	8	PASS

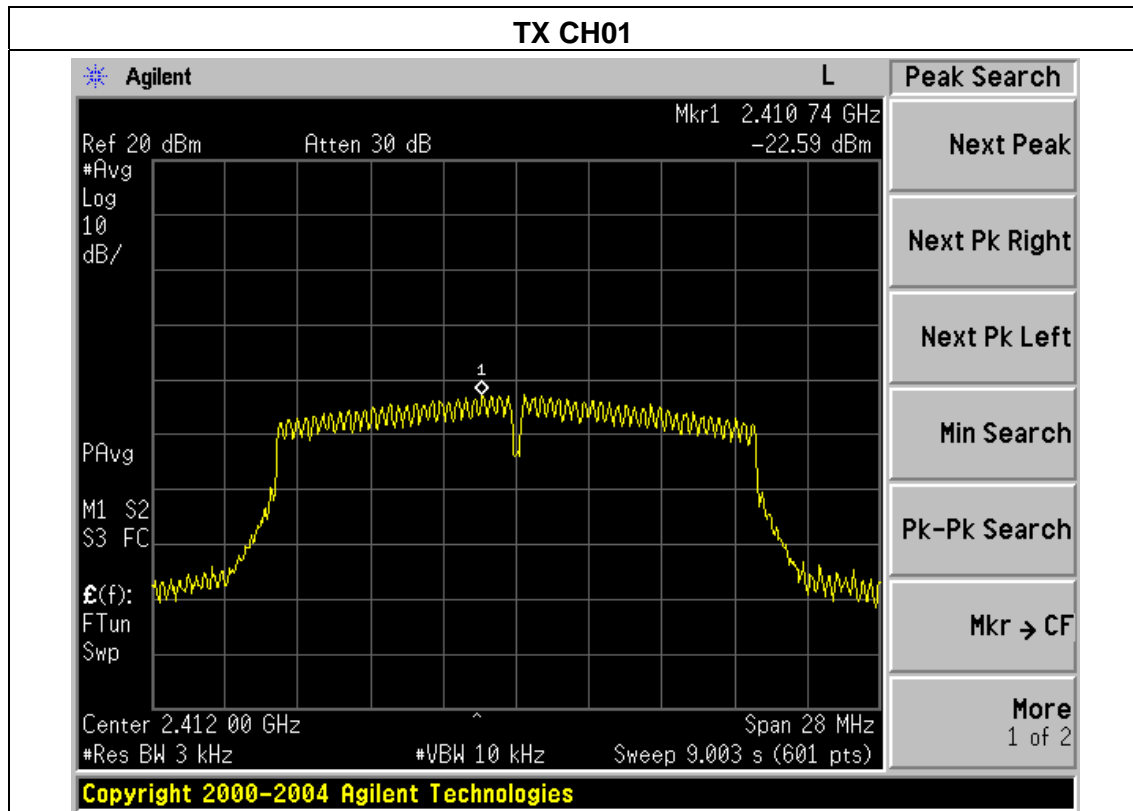

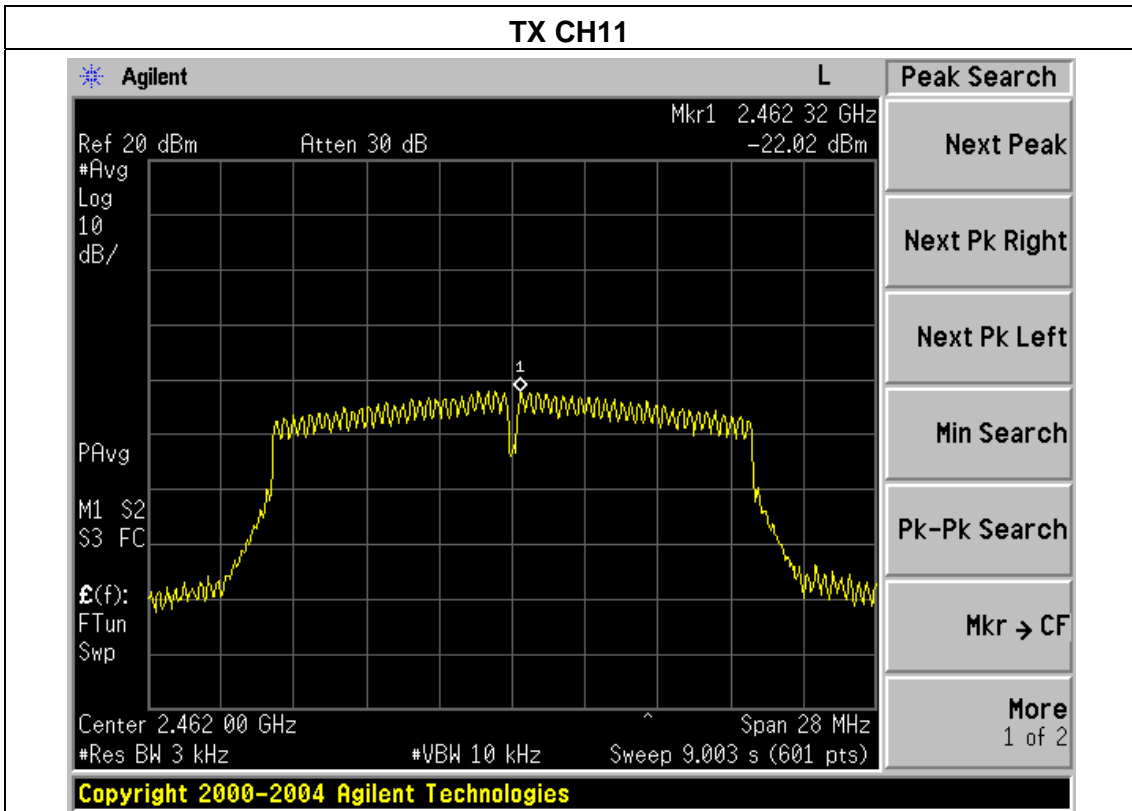
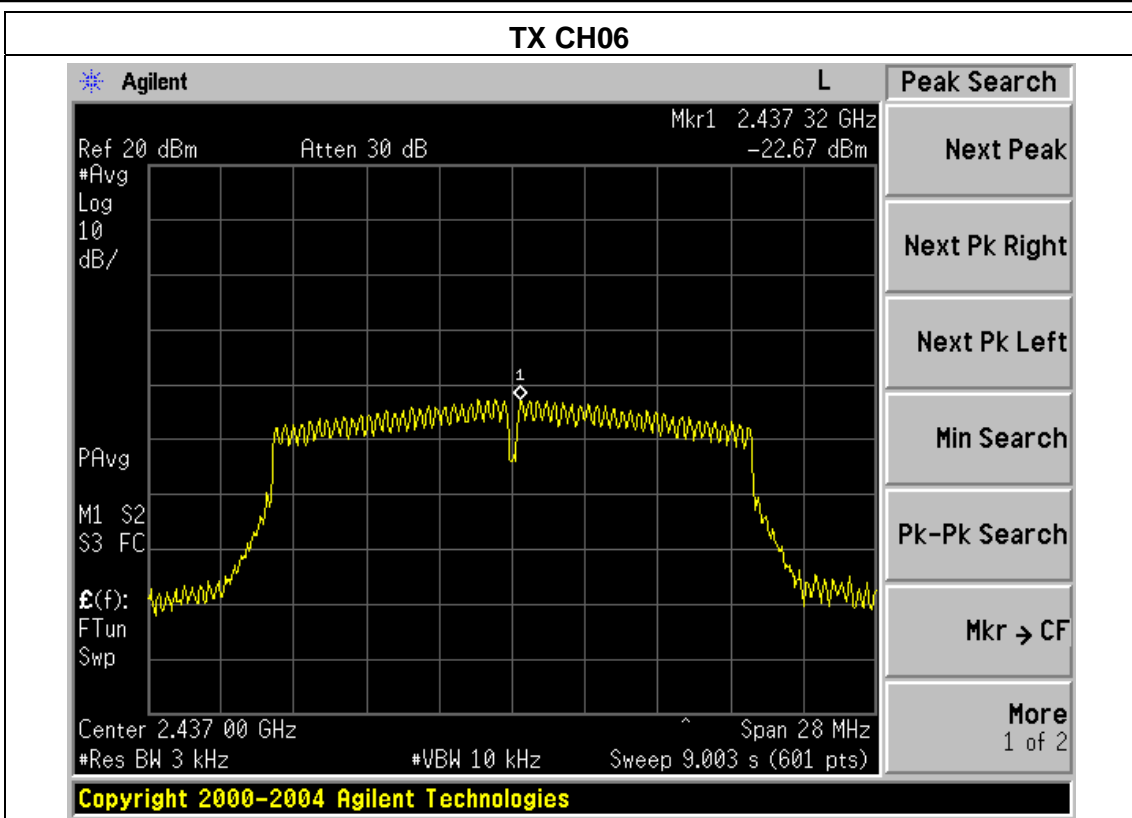

**5. 6DB BANDWIDTH TEST**

**5.1 APPLIED PROCEDURES / LIMIT**

FCC Part15 (15.247) , Subpart C				
Section	Test Item	Limit	Frequency Range (MHz)	Result
15.247(a)(2)	Bandwidth	$\geq 500\text{KHz}$ (6dB bandwidth)	2400-2483.5	PASS

**5.1.1 TEST PROCEDURE**

1. Set RBW = 100 kHz.
2. Set the video bandwidth (VBW)  $\geq 3 \times$  RBW.
3. Detector = Peak.
4. Trace mode = max hold.
5. Sweep = auto couple.
6. Allow the trace to stabilize.
7. Measure the maximum width of the emission that is constrained by the frequencies associated with the two outermost amplitude points (upper and lower) that are attenuated by 6 dB relative to the maximum level measured in the fundamental emission.

**TEST SETUP**

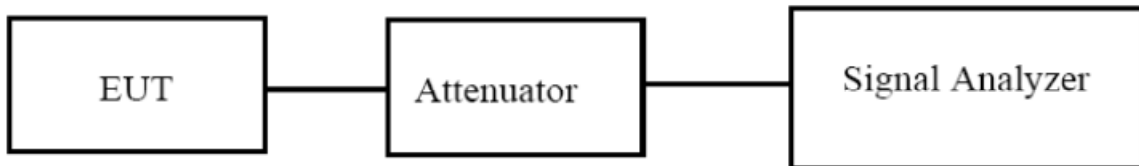

**5.1.2 EUT OPERATION CONDITIONS**

The EUT tested system was configured as the statements of 2.4 Unless otherwise a special operating condition is specified in the follows during the testing.

### 5.1.3 TEST RESULTS

EUT :	Alpha Intelligent Robot 2	Model Name :	Alpha 2
Temperature :	25 °C	Relative Humidity :	56%
Pressure :	1012 hPa	Test Voltage :	DC 11.1V
Test Mode :	TX b Mode /CH01, CH06, CH11		

Channel	Frequency (MHz)	6dB bandwidth (MHz)	Limit (kHz)	Result
Low	2412	7.581	>= 500KHz	Pass
Middle	2437	7.120	>= 500KHz	Pass
High	2462	7.083	>= 500KHz	Pass

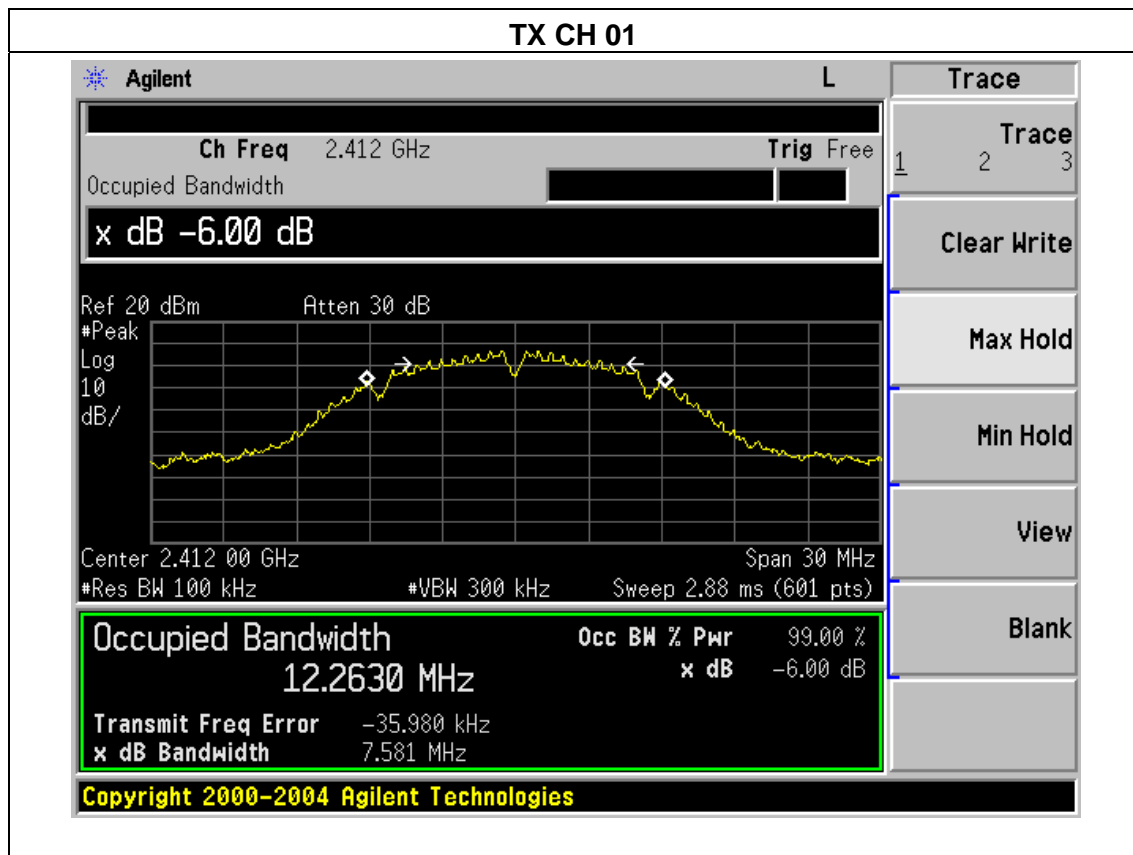

**TX CH 06**

Agilent
L

**Ch Freq** 2.437 GHz **Trig** Free

Occupied Bandwidth

**Center 2.437000000 GHz**

Ref 20 dBm
Atten 30 dB

#Peak

Log

10

dB/

Center 2.437 00 GHz
Span 30 MHz

#Res BW 100 kHz
#VBW 300 kHz
Sweep 2.88 ms (601 pts)

<b>Occupied Bandwidth</b>	<b>Occ BW % Pwr</b>	99.00 %
12.2009 MHz	x dB	-6.00 dB
<b>Transmit Freq Error</b>	-56.480 kHz	
<b>x dB Bandwidth</b>	7.120 MHz	

Copyright 2000-2004 Agilent Technologies

**Trace**

Trace 1 2 3

Clear Write

Max Hold

Min Hold

View

Blank

**TX CH 11**

Agilent
L

**Ch Freq** 2.462 GHz **Trig** Free

Occupied Bandwidth

**Center 2.462000000 GHz**

Ref 20 dBm
Atten 30 dB

#Peak

Log

10

dB/

Center 2.462 00 GHz
Span 30 MHz

#Res BW 100 kHz
#VBW 300 kHz
Sweep 2.88 ms (601 pts)

<b>Occupied Bandwidth</b>	<b>Occ BW % Pwr</b>	99.00 %
12.0489 MHz	x dB	-6.00 dB
<b>Transmit Freq Error</b>	-42.185 kHz	
<b>x dB Bandwidth</b>	7.083 MHz	

Copyright 2000-2004 Agilent Technologies

**Trace**

Trace 1 2 3

Clear Write

Max Hold

Min Hold

View

Blank



EUT :	Alpha Intelligent Robot 2	Model Name :	Alpha 2
Temperature :	25 °C	Relative Humidity :	60%
Pressure :	1012 hPa	Test Voltage :	DC 11.1V
Test Mode :	TX g Mode /CH01, CH06, CH11		

Channel	Frequency (MHz)	6dB bandwidth (MHz)	Limit (kHz)	Result
Low	2412	15.143	>= 500KHz	Pass
Middle	2437	15.184	>= 500KHz	Pass
High	2462	15.164	>= 500KHz	Pass

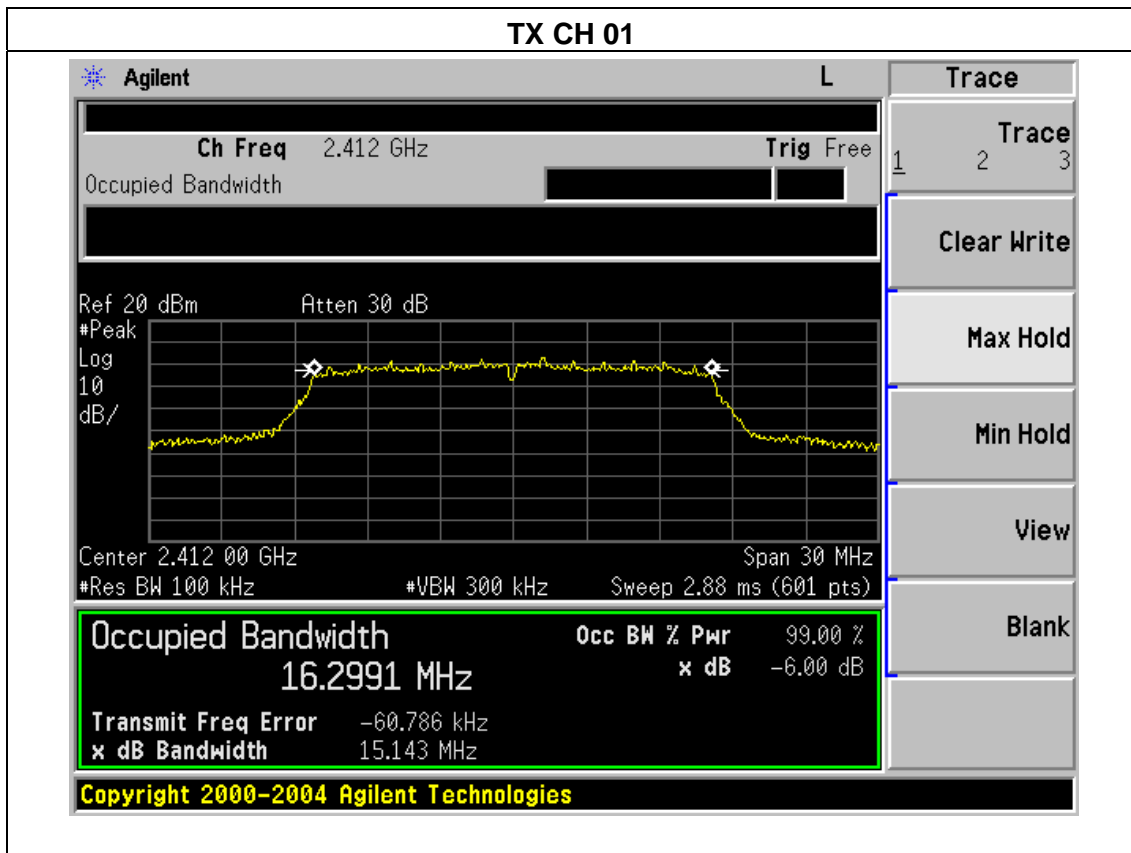

**TX CH 06**

Agilent
L

Ch Freq 2.437 GHz Trig Free

Occupied Bandwidth

**Center 2.437000000 GHz**

Ref 20 dBm    Atten 30 dB

#Peak

Log

10

dB/

Span 30 MHz

Center 2.437 00 GHz

#Res BW 100 kHz    #VBW 300 kHz    Sweep 2.88 ms (601 pts)

**Occupied Bandwidth**

**16.3179 MHz**

Transmit Freq Error -60.761 kHz

x dB Bandwidth 15.184 MHz

Occ BW % Pwr 99.00 %

x dB -6.00 dB

Copyright 2000-2004 Agilent Technologies

Trace

Trace 1 2 3

Clear Write

Max Hold

Min Hold

View

Blank

**TX CH 11**

Agilent
L

Ch Freq 2.462 GHz Trig Free

Occupied Bandwidth

**Center 2.462000000 GHz**

Ref 20 dBm    Atten 30 dB

#Peak

Log

10

dB/

Span 30 MHz

Center 2.462 00 GHz

#Res BW 100 kHz    #VBW 300 kHz    Sweep 2.88 ms (601 pts)

**Occupied Bandwidth**

**16.3125 MHz**

Transmit Freq Error -58.685 kHz

x dB Bandwidth 15.164 MHz

Occ BW % Pwr 99.00 %

x dB -6.00 dB

Copyright 2000-2004 Agilent Technologies

Trace

Trace 1 2 3

Clear Write

Max Hold

Min Hold

View

Blank

EUT :	Alpha Intelligent Robot 2	Model Name :	Alpha 2
Temperature :	25 °C	Relative Humidity :	56%
Pressure :	1012 hPa	Test Voltage :	DC 11.1V
Test Mode :	TX n Mode(20M) /CH01, CH06, CH11		

Channel	Frequency (MHz)	6dB bandwidth (MHz)	Limit (kHz)	Result
Low	2412	15.141	>= 500KHz	Pass
Middle	2437	16.017	>= 500KHz	Pass
High	2462	15.110	>= 500KHz	Pass

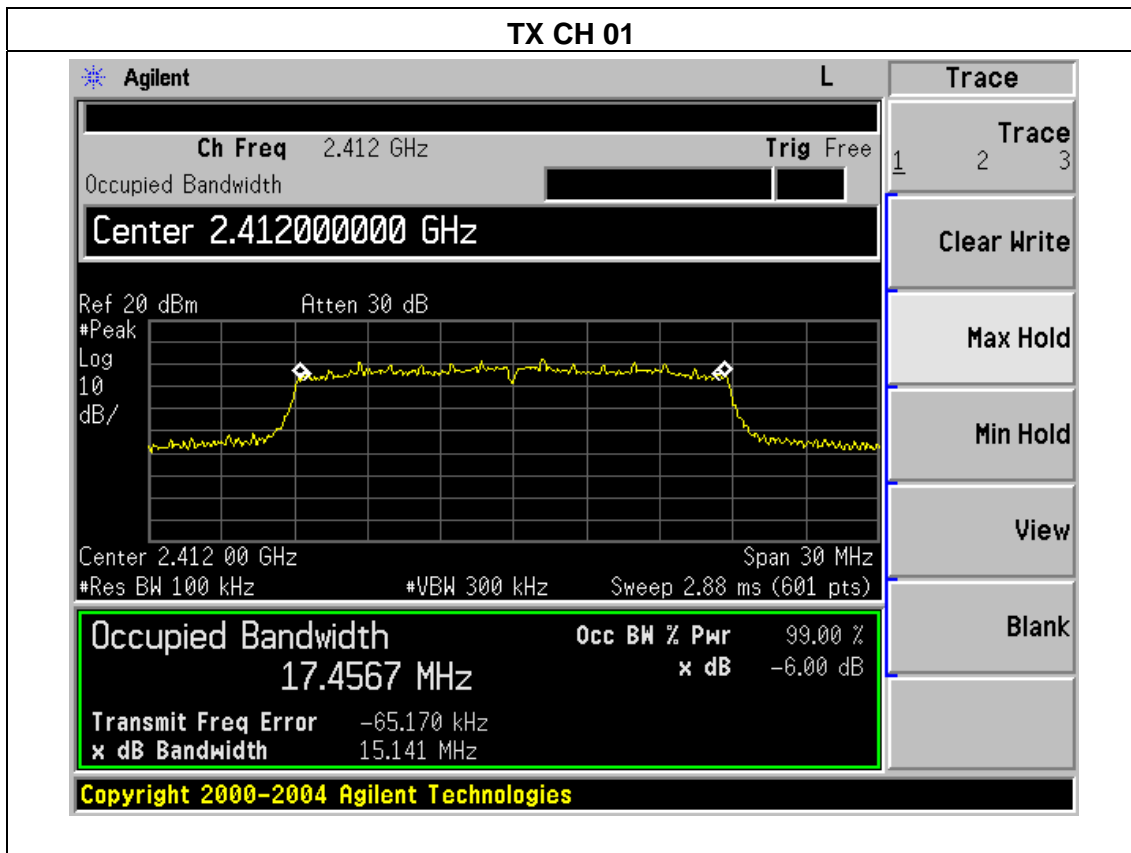

### TX CH 06

Agilent
L

Ch Freq 2.437 GHz
Trig Free

Ref 20 dBm    Atten 30 dB

#Peak

Log 10 dB/

Center 2.437 00 GHz    Span 30 MHz  
#Res BW 100 kHz    #VBW 300 kHz    Sweep 2.88 ms (601 pts)

**Occupied Bandwidth**    Occ BW % Pwr    99.00 %

17.4717 MHz

Transmit Freq Error    -62.884 kHz

x dB Bandwidth    16.017 MHz

Copyright 2000-2004 Agilent Technologies

Trace

Trace 1 2 3

Clear Write

Max Hold

Min Hold

View

Blank

### TX CH 11

Agilent
L

Ch Freq 2.462 GHz
Trig Free

Ref 20 dBm    Atten 30 dB

#Peak

Log 10 dB/

Center 2.462 00 GHz    Span 30 MHz  
#Res BW 100 kHz    #VBW 300 kHz    Sweep 2.88 ms (601 pts)

**Occupied Bandwidth**    Occ BW % Pwr    99.00 %

17.4561 MHz

Transmit Freq Error    -55.902 kHz

x dB Bandwidth    15.110 MHz

Copyright 2000-2004 Agilent Technologies

Trace

Trace 1 2 3

Clear Write

Max Hold

Min Hold

View

Blank

## 6. 20DB BANDWIDTH

### 6.1 APPLICABLE STANDARD

According to FCC Part 15.247(a)(2) and KDB 558074 DTS 01 Meas. Guidance v03r04

#### 6.1.1 CONFORMANCE LIMIT

The minimum permissible 6dB bandwidth is 500 kHz.

#### 6.1.2 MEASURING INSTRUMENTS

The Measuring equipment is listed in the section 6.3 of this test report.

#### 6.1.3 TEST SETUP

Please refer to Section 6.1 of this test report.

#### 6.1.4 TEST PROCEDURE

The testing follows KDB 558074 DTS 01 Meas. Guidance v03r04

The RF output of EUT was connected to the spectrum analyzer by RF cable and attenuator.

The path loss was compensated to the results for each measurement.

Set to the maximum power setting and enable the EUT transmit continuously.

The EUT was operating in controlled its channel.

Use the following spectrum analyzer settings:

Span = the frequency band of operation

RBW = 100KHz

VBW  $\geq$  3\*RBW

Sweep = auto

Detector function = peak

Trace = max hold



20dB Bandwidth plot on channel 6

802.11b

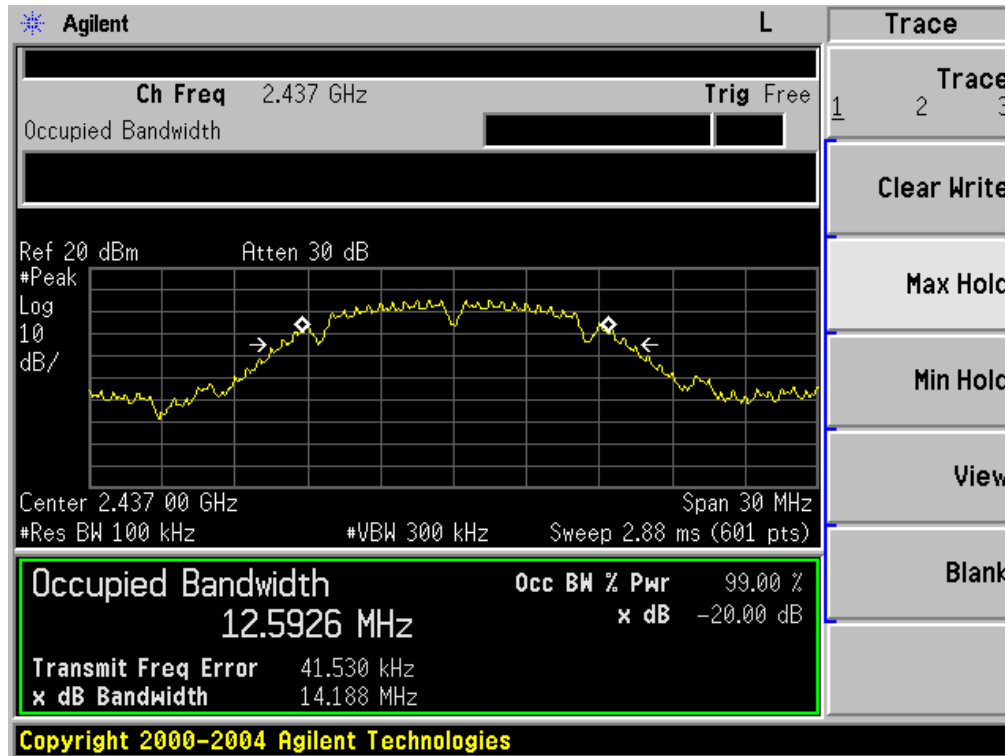

20dB Bandwidth plot on channel 11

802.11b

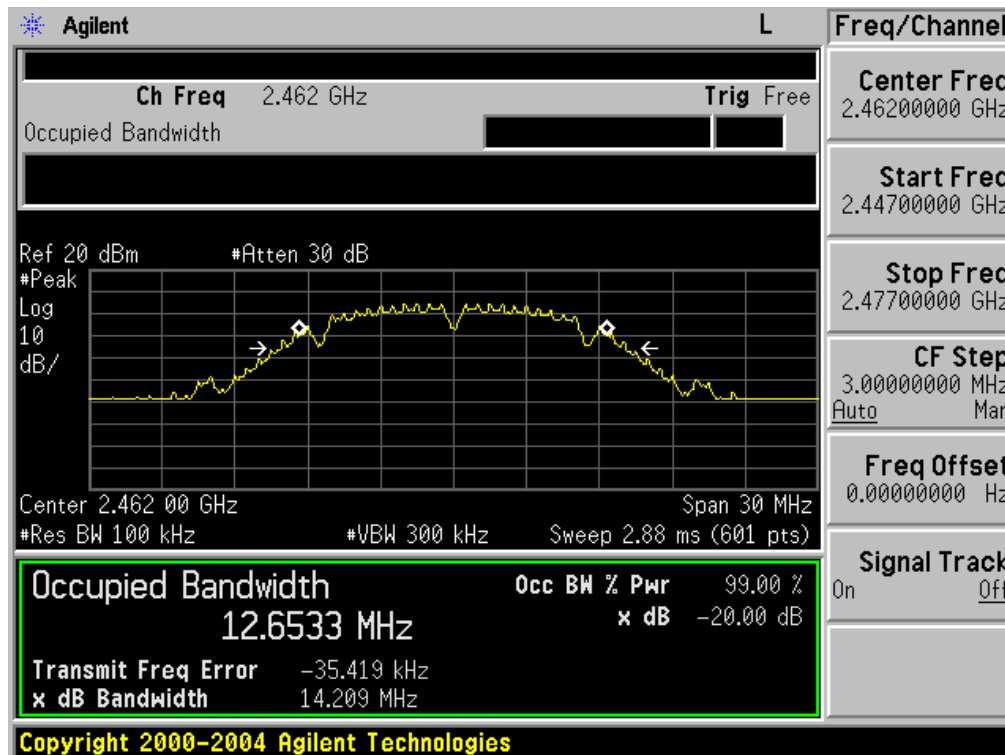

20dB Bandwidth plot on channel 1

802.11g

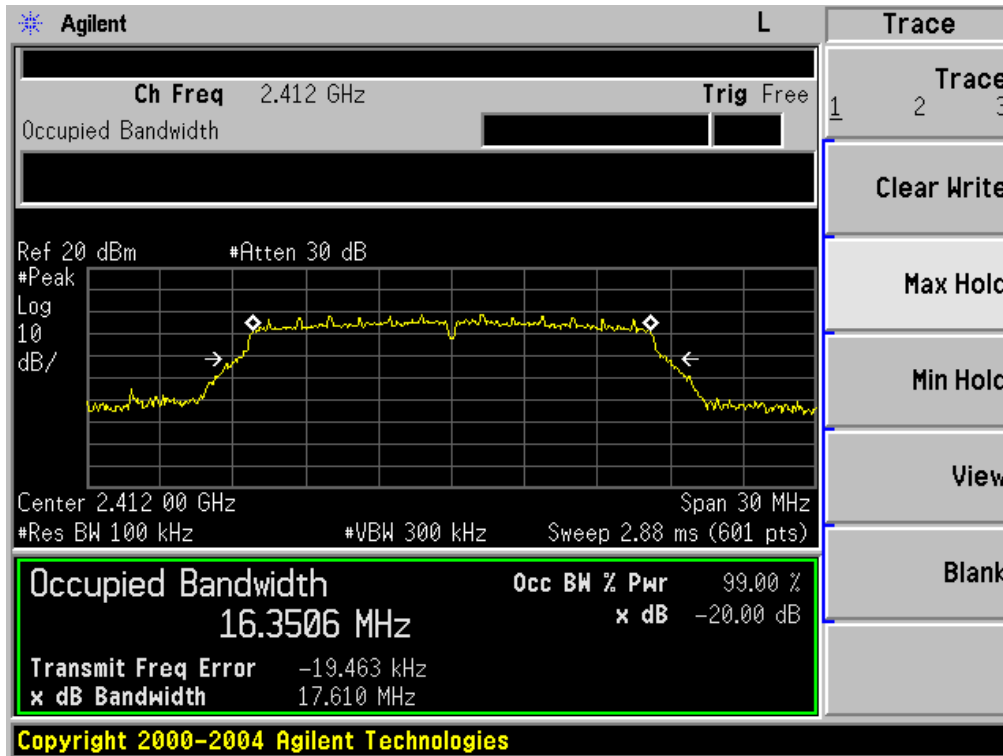

20dB Bandwidth plot on channel 6

802.11g

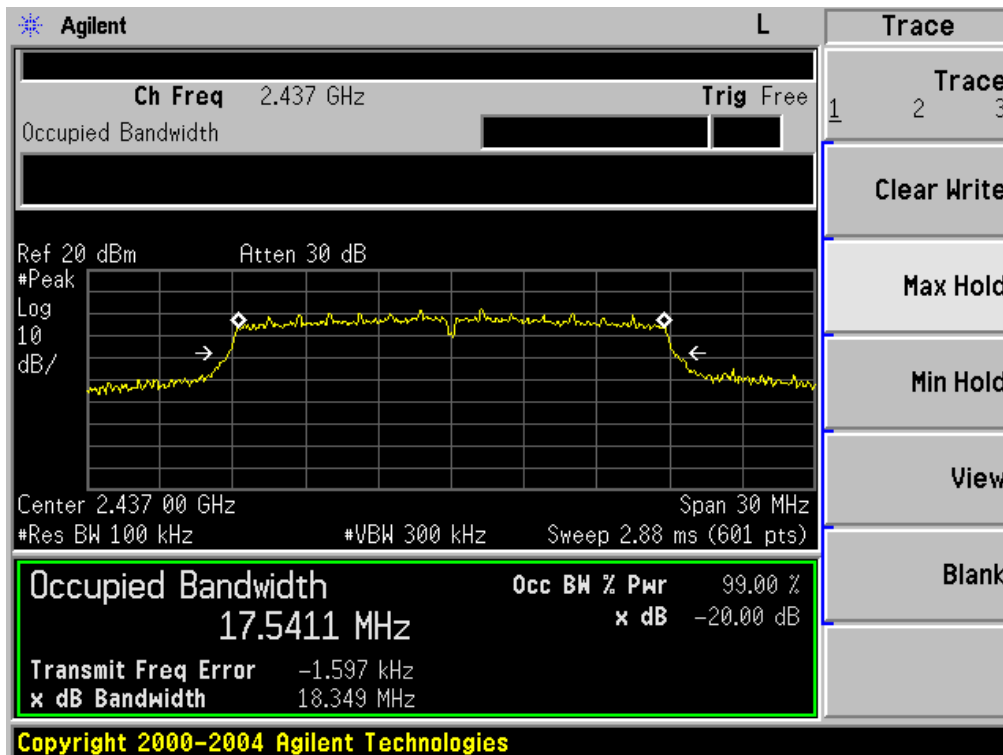



20dB Bandwidth plot on channel 11 802.11g

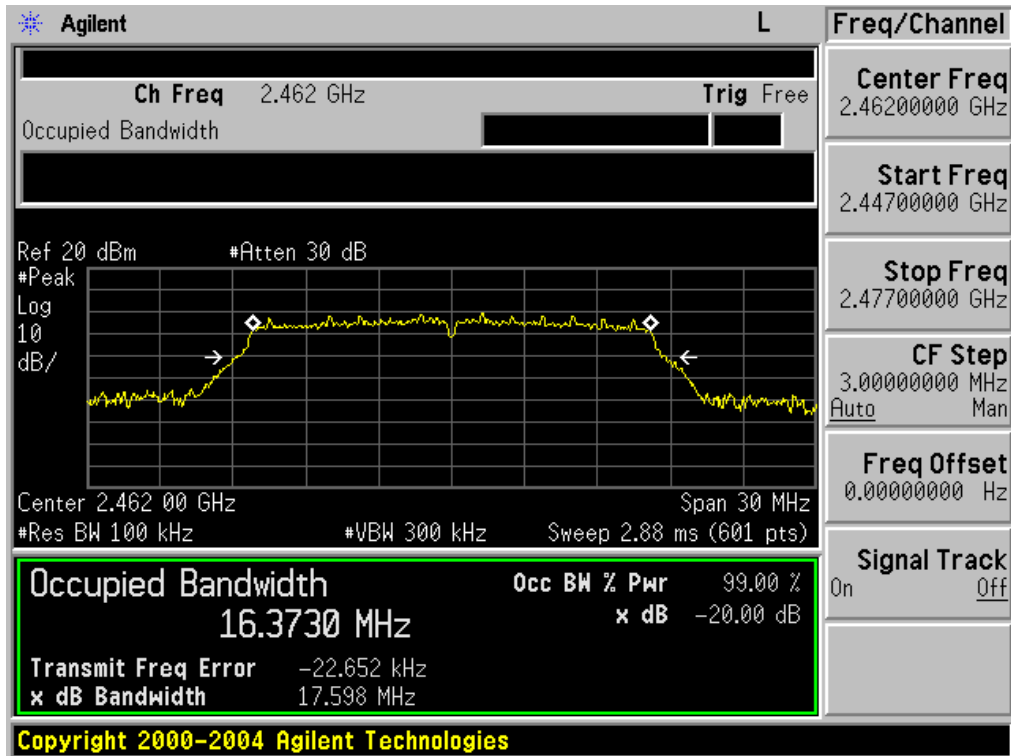

20dB Bandwidth plot on channel 1 802.11n HT20

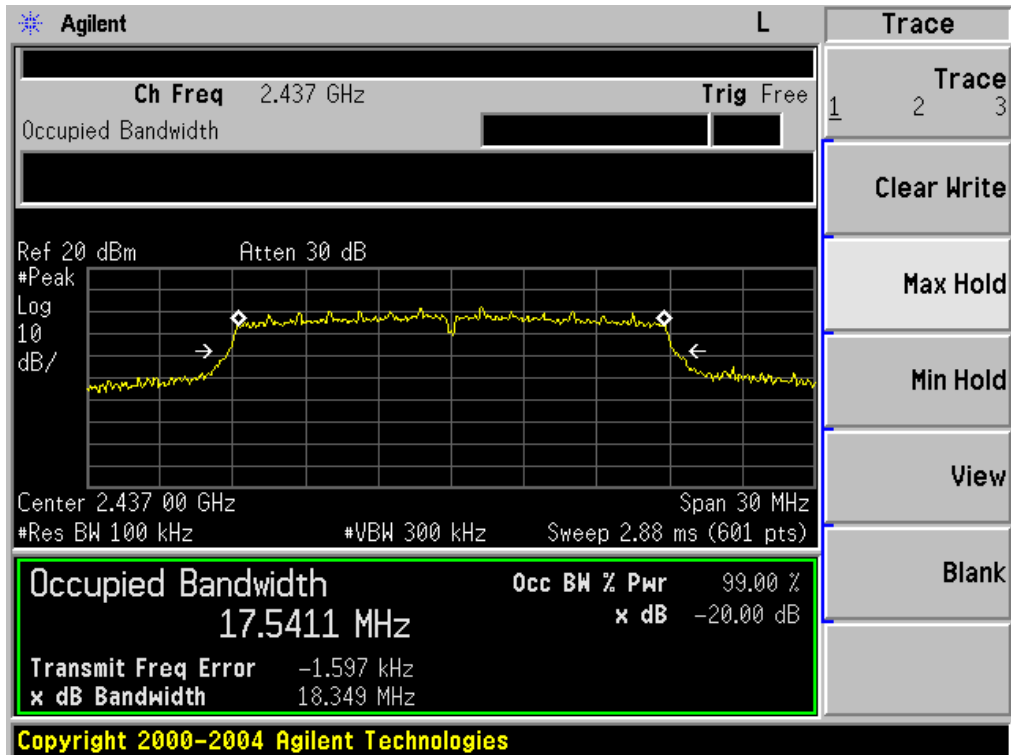

20dB Bandwidth plot on channel 6

802.11n HT20

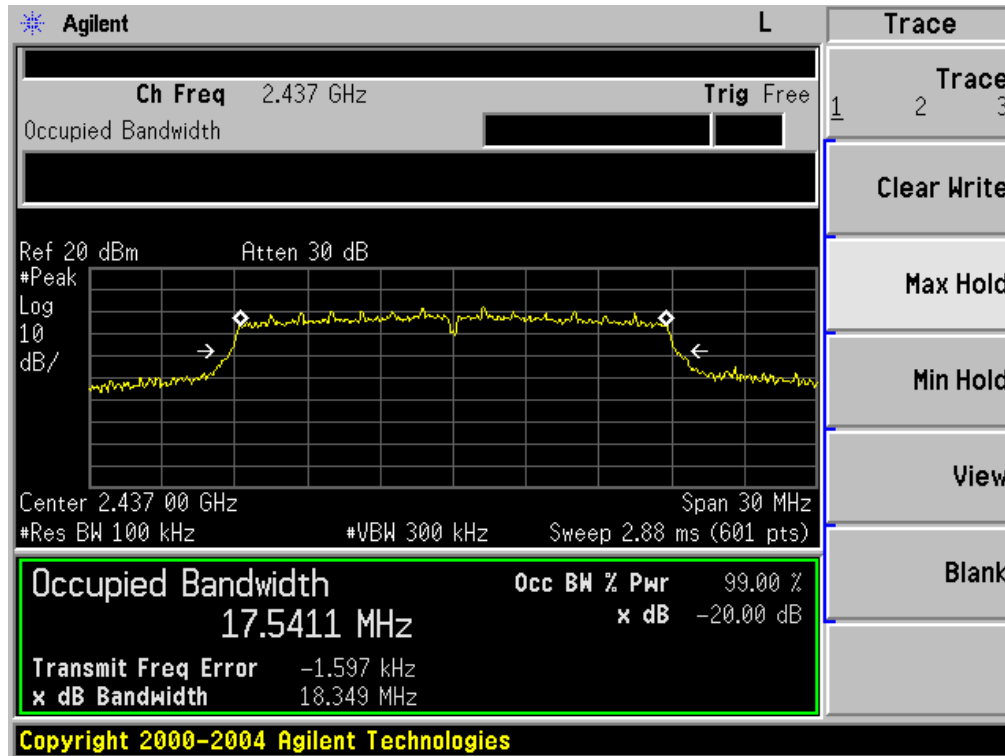

20dB Bandwidth plot on channel 11

802.11n HT20

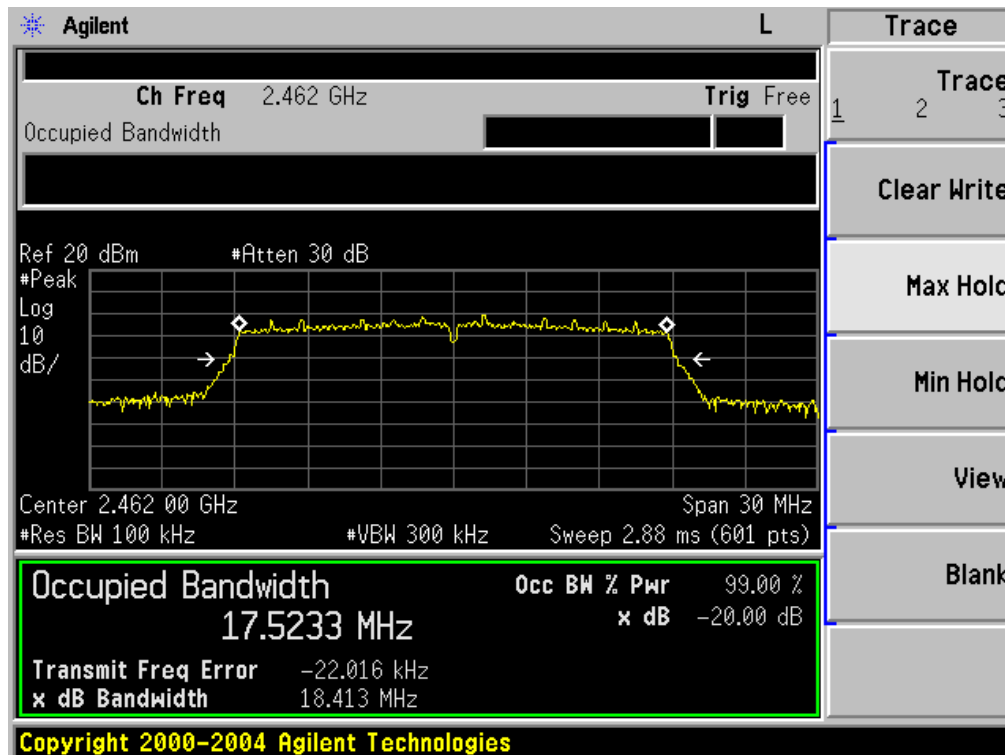

## 7. DUTY CYCLE

### 7.1 APPLICABLE STANDARD

According to KDB 558074)6)b), issued 06/09/2015

#### 7.1.1 CONFORMANCE LIMIT

No limit requirement.

#### 7.1.2 MEASURING INSTRUMENTS

The Measuring equipment is listed in the section 6.3 of this test report.

#### 7.1.3 TEST SETUP

Please refer to Section 6.1 of this test report.

#### 7.1.4 TEST PROCEDURE

The zero-span mode on a spectrum analyzer or EMI receiver if the response time and spacing between bins on the sweep are sufficient to permit accurate measurements of the on and off times of the transmitted signal. Set the center frequency of the instrument to the center frequency of the transmission. Set  $RBW \geq OBW$  if possible, otherwise, set RBW to the largest available value. Set  $VBW \geq RBW$ . Set detector = peak or average. The zero-span measurement method shall not be used unless both RBW and VBW are  $> 50/T$  and the number of sweep points across duration T exceeds 100. (For example, if VBW and/or RBW are limited to 3 MHz, then the zero-span method of measuring duty cycle shall not be used if  $T \leq 16.7$  microseconds.)

The transmitter output is connected to the Spectrum Analyzer. We tested according to the zero-span measurement method, 6.0)b) in KDB 558074(issued 06/09/2015)

The largest available value of RBW is 8 MHz and VBW is 50 MHz. The zero-span method of measuring duty cycle shall not be used if  $T \leq 6.25$  microseconds. ( $50/6.25 = 8$ )

The zero-span method was used because all measured T data are  $> 6.25$  microseconds and both RBW and VBW are  $> 50/T$ .

The RF output of EUT was connected to the spectrum analyzer by RF cable and attenuator.

The path loss was compensated to the results for each measurement.

Set to the maximum power setting and enable the EUT transmit continuously.

The EUT was operating in controlled its channel.

Use the following spectrum analyzer settings:

Span = Zero Span

RBW = 8MHz(the largest available value)

VBW = 8MHz ( $\geq$  RBW)

Number of points in Sweep  $> 100$

Detector function = peak

Trace = Clear write

Measure  $T_{total}$  and  $T_{on}$

Calculate Duty Cycle =  $T_{on} / T_{total}$  and Duty Cycle Factor =  $10 \cdot \log(1/Duty\ Cycle)$

### 7.2 TEST RESULTS

EUT :	Alpha Intelligent Robot 2	Model Name :	Alpha 2
Temperature :	25 °C	Relative Humidity :	56%
Pressure :	1012 hPa	Test Voltage :	DC 11.1V
Test Mode :	TX b/g/n20 Mode / CH06		

Mode	Data rate	Channel	T <sub>on</sub>	T <sub>total</sub>	Duty Cycle	Duty Cycle Factor (dB)
802.11b	1Mbps	6	8.467	8.50	0.9960	0.017
802.11g	6Mbps	6	2.080	2.224	0.9604	0.175
802.11n HT20	MCS0	6	1.936	2.080	0.9308	0.311

Duty Cycle plot on channel 6 802.11b

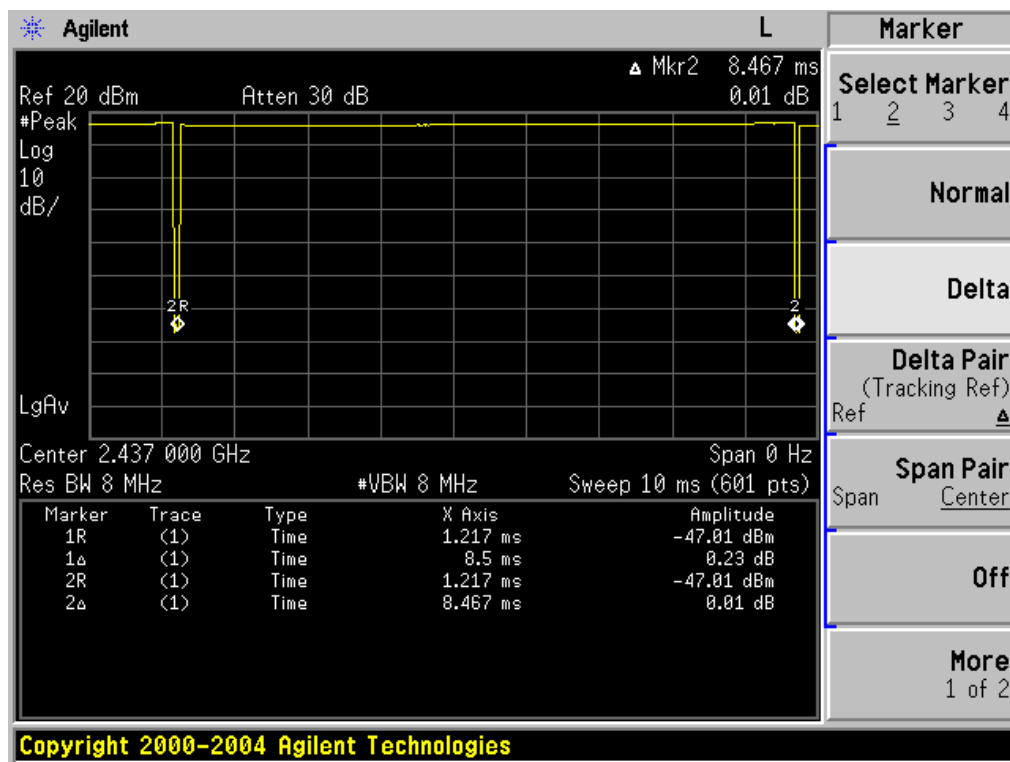

Duty Cycle plot on channel 6

802.11g

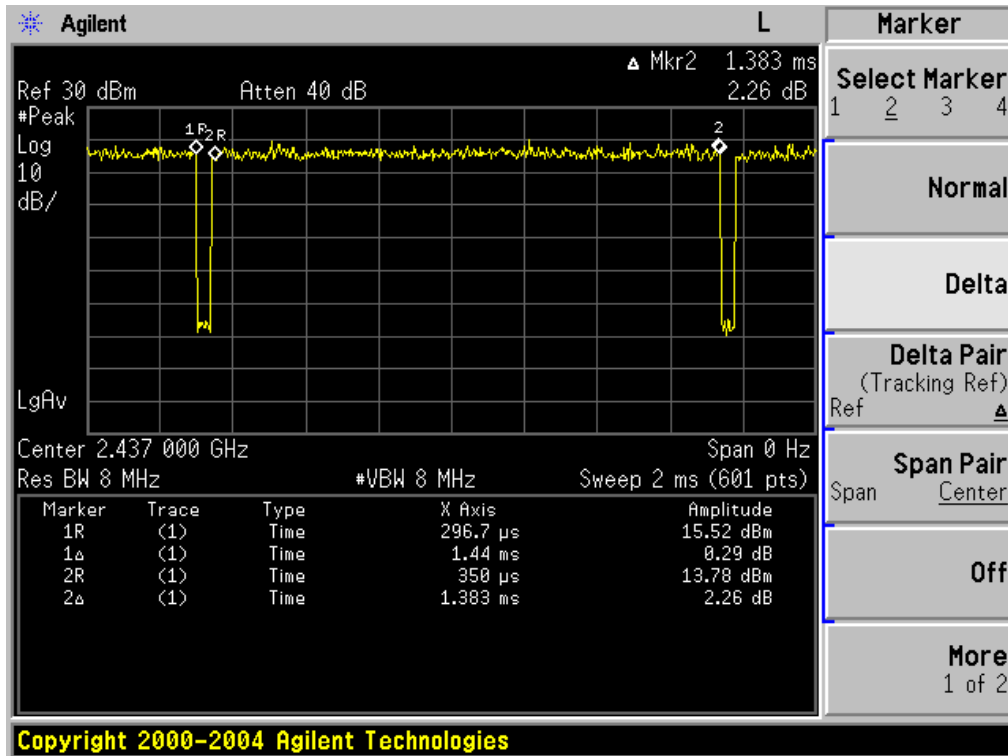

Duty Cycle plot on channel 6

802.11n HT20

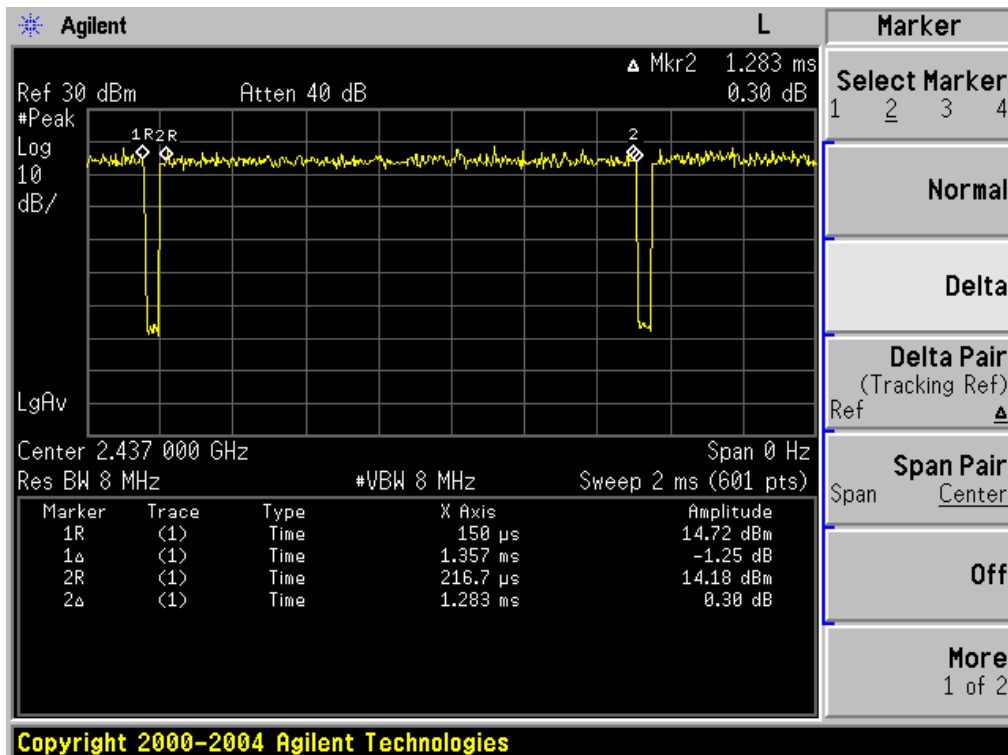

**8. MAXIMUM OUTPUT POWER TEST**

**8.1 APPLIED PROCEDURES / LIMIT**

FCC Part15 (15.247) , Subpart C				
Section	Test Item	Limit	Frequency Range (MHz)	Result
15.247(b)(3)	Peak Output Power	1 watt or 30dBm	2400-2483.5	PASS

**8.1.1 TEST PROCEDURE**

**a. 9.2.2.3 Method AVGSA-1 Alternative (RMS detection with slow sweep and EUT transmitting continuously at full power)**

- a) Set span to at least 1.5 times the OBW.
  - b) Set RBW = 1-5% of the OBW, not to exceed 1 MHz.
  - c) Set VBW  $\geq 3 \times$  RBW.
  - d) Number of points in sweep  $\geq 2 \times$  span / RBW. (This gives bin-to-bin spacing  $\leq$  RBW/2, so that narrowband signals are not lost between frequency bins.)
  - e) Manually set sweep time  $\geq 10 \times$  (number of points in sweep)  $\times$  (transmission symbol period), but not less than the automatic default sweep time.
- NOTE— The transmission symbol period (in seconds) is the reciprocal of the symbol rate (in baud or symbols per second). Note that each symbol can represent one or several data bits and thus the symbol rate should not be confused with the gross bit rate (expressed in bits/second). In no case should the sweep time be set less than the auto sweep time.
- f) Set detector = RMS.
  - g) The EUT shall be operated at  $\geq 98 \%$  duty cycle or sweep triggering/signal gating shall be employed such that the sweep time is less than or equal to the transmission duration T.
  - h) Perform a single sweep.
  - i) Compute power by integrating the spectrum across the OBW of the signal using the instrument's band power measurement function, with band limits set equal to the OBW band edges. If the instrument does not have a band power function, sum the spectrum levels (in power units) at intervals equal to the RBW extending across the entire OBW of the spectrum.

**8.1.2 DEVIATION FROM STANDARD**

No deviation.

**8.1.3 TEST SETUP**

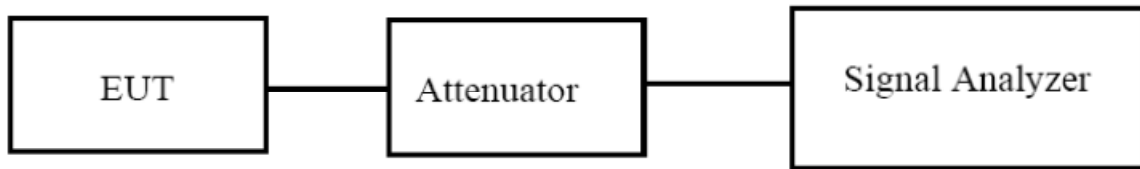

**8.1.4 EUT OPERATION CONDITIONS**

The EUT tested system was configured as the statements of 2.4 Unless otherwise a special operating condition is specified in the follows during the testing.

### 8.2 TEST RESULTS

EUT :	Alpha Intelligent Robot 2	Model Name :	Alpha 2
Temperature :	25 °C	Relative Humidity :	60%
Pressure :	1012 hPa	Test Voltage :	DC 11.1V
Test Mode :	TX b/g/n(20M) Mode		

<b>TX 802.11b Mode</b>			
Test Channel	Frequency	Maximum Conducted Output Power (AV)	LIMIT
	(MHz)	(dBm)	dBm
CH01	2412	12.38	30
CH06	2437	12.72	30
CH11	2462	13.01	30
<b>TX 802.11g Mode</b>			
CH01	2412	9.16	30
CH06	2437	9.55	30
CH11	2462	9.25	30
<b>TX 802.11n(20) Mode</b>			
CH01	2412	7.59	30
CH06	2437	7.96	30
CH11	2462	7.52	30



802.11b Mode

TX CH 01

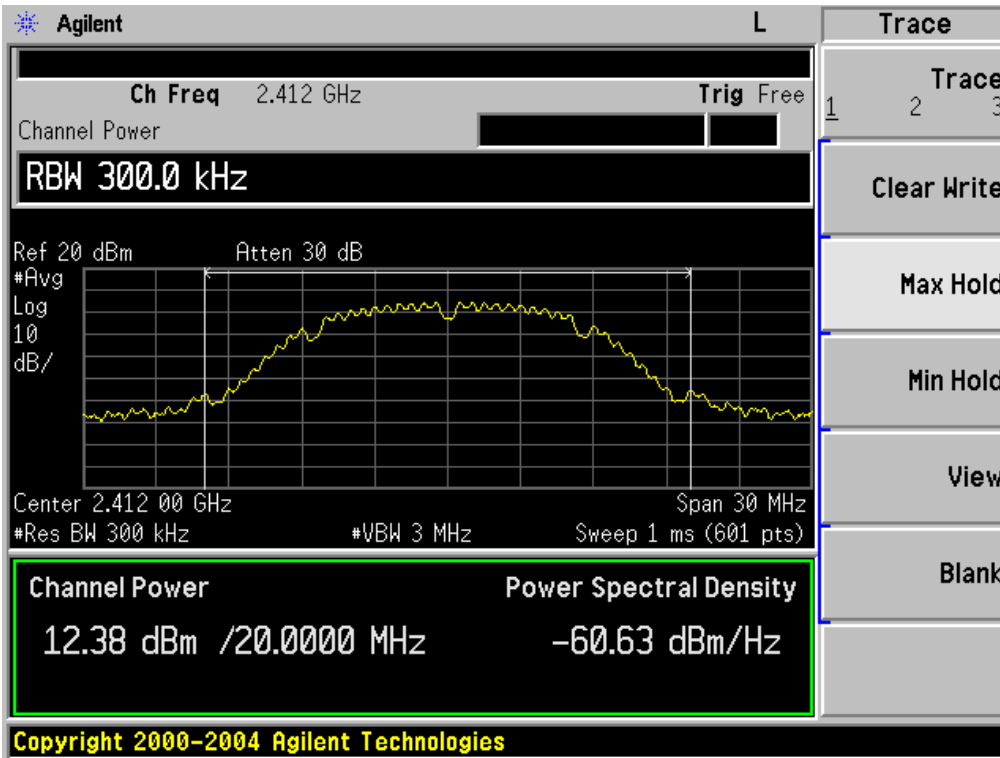

TX CH 06

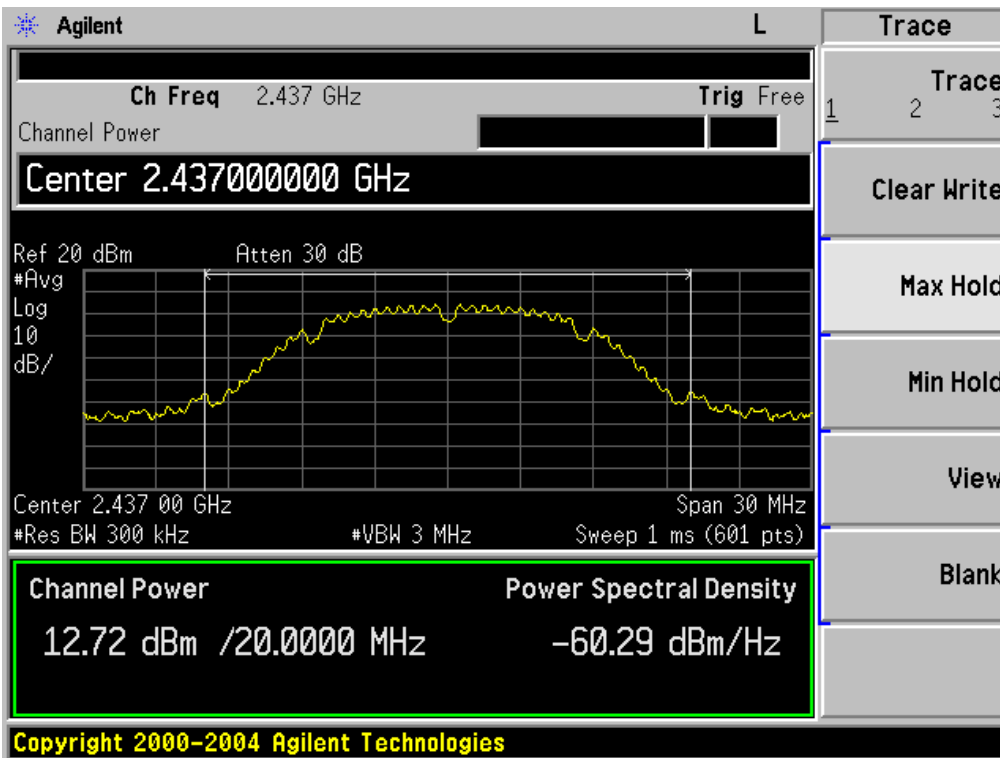

**TX CH 11**

Agilent L

Ch Freq 2.462 GHz Trig Free

Channel Power

**Center 2.462000000 GHz**

Ref 20 dBm Atten 30 dB

#Avg Log 10 dB/

Center 2.462 00 GHz Span 30 MHz  
#Res BW 300 kHz #VBW 3 MHz Sweep 1 ms (601 pts)

**Channel Power** **Power Spectral Density**  
13.01 dBm /20.0000 MHz -60.00 dBm/Hz

Trace 1 2 3

Clear Write

Max Hold

Min Hold

View

Blank

Copyright 2000-2004 Agilent Technologies

**802.11g Mode**

**TX CH 01**

Agilent L

Ch Freq 2.412 GHz Trig Free

Channel Power

**Center 2.412000000 GHz**

Ref 20 dBm Atten 30 dB

#Avg Log 10 dB/

Center 2.412 00 GHz Span 30 MHz  
#Res BW 300 kHz #VBW 3 MHz Sweep 1 ms (601 pts)

**Channel Power** **Power Spectral Density**  
9.16 dBm /20.0000 MHz -63.85 dBm/Hz

Trace 1 2 3

Clear Write

Max Hold

Min Hold

View

Blank

Copyright 2000-2004 Agilent Technologies

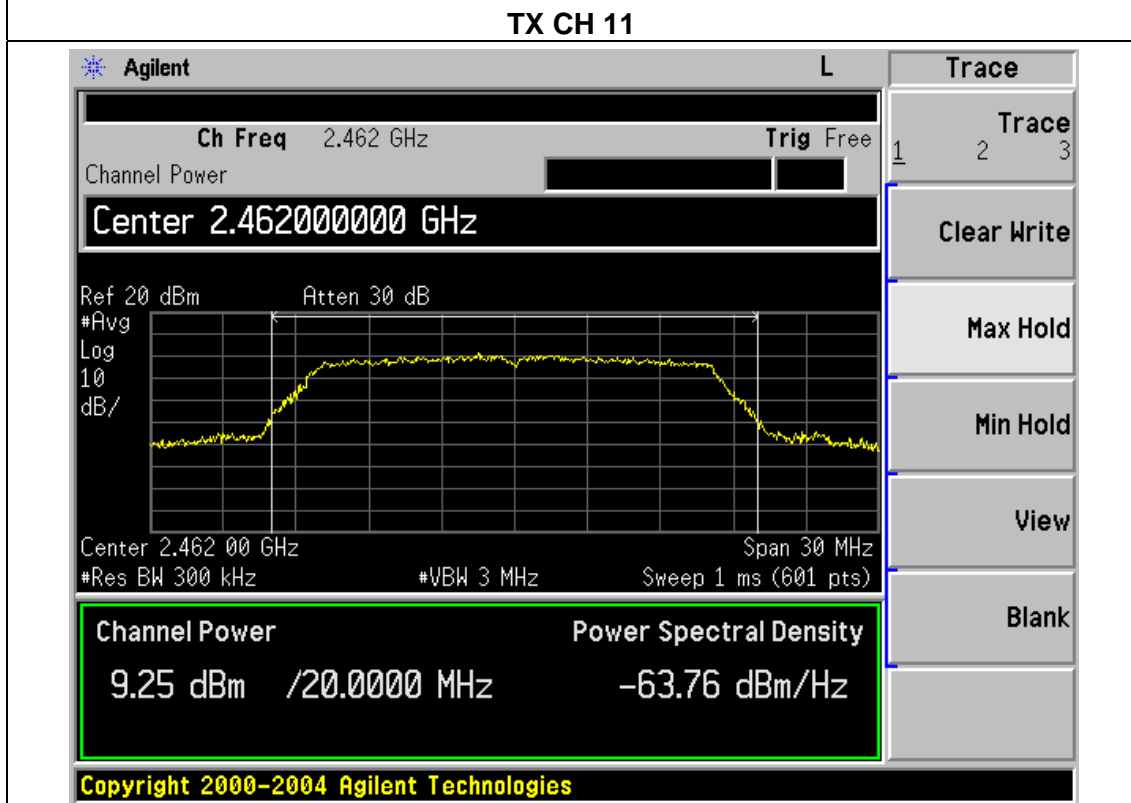
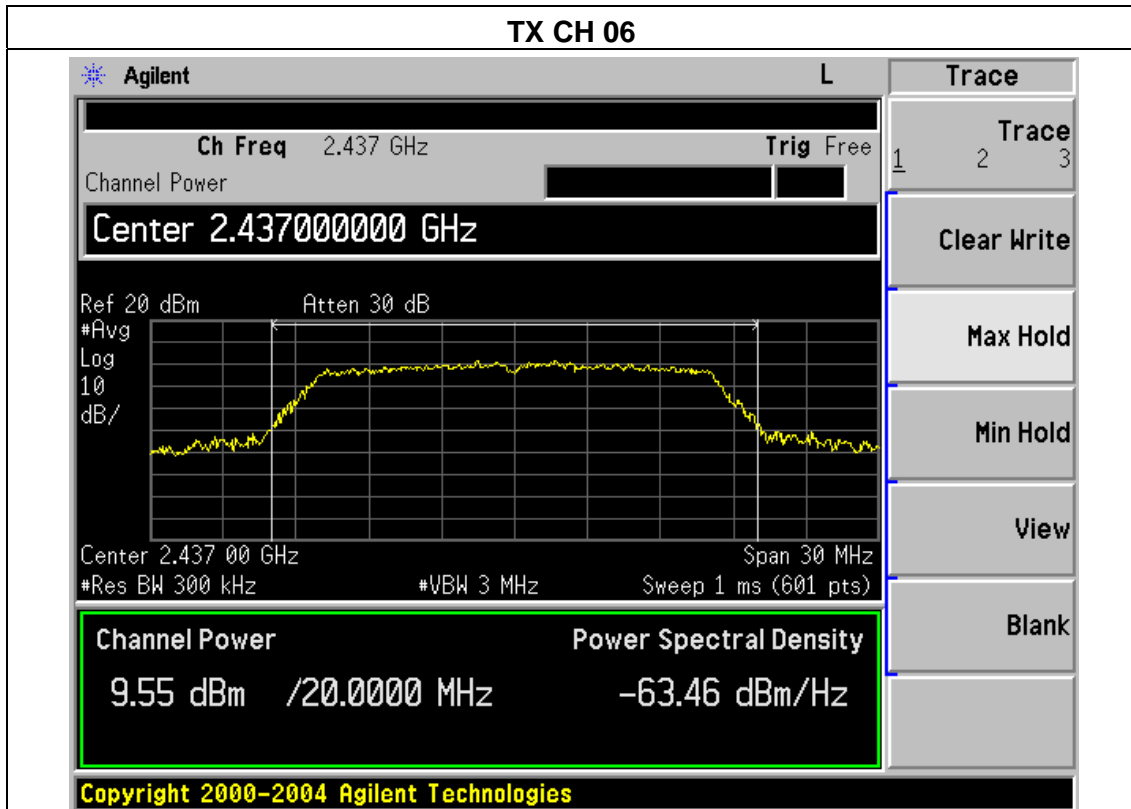

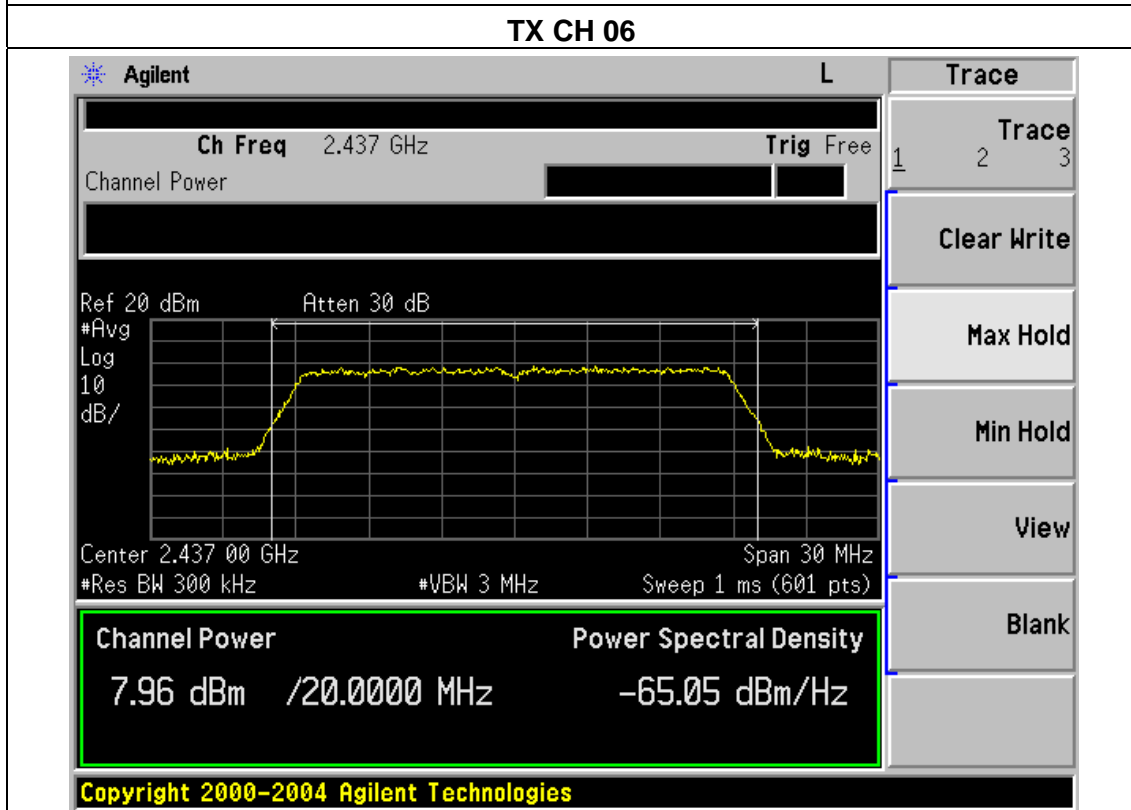
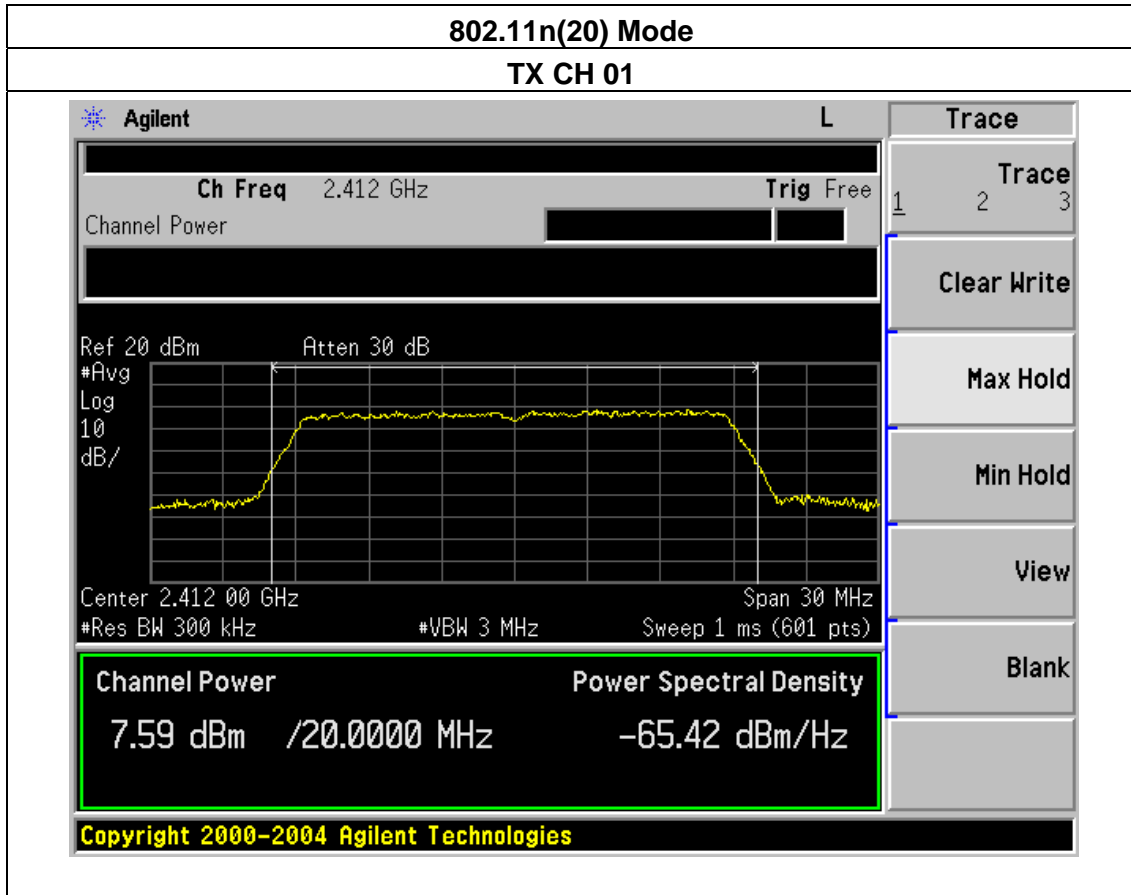

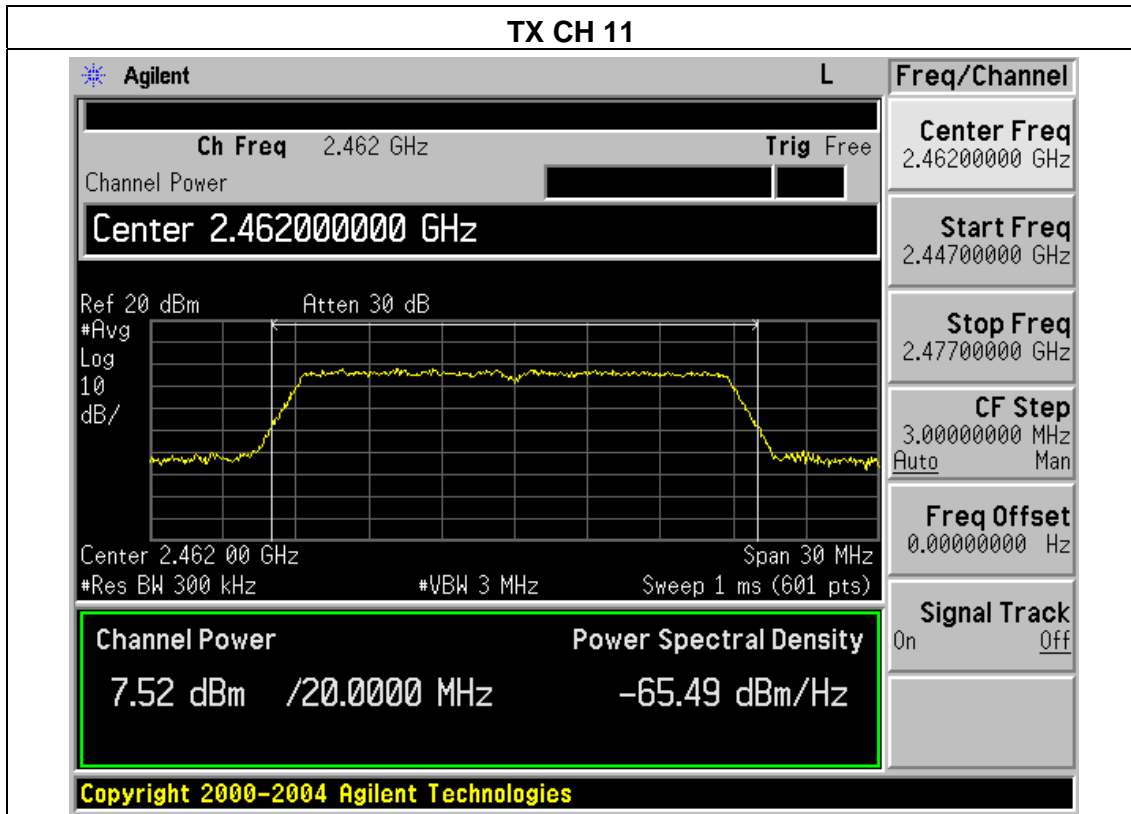

## 9. 100 KHZ BANDWIDTH OF FREQUENCY BAND EDGE

### 9.1 APPLICABLE STANDARD

According to FCC Part 15.247(d) and KDB 558074 DTS 01 Meas. Guidance v03r04

When performing peak or average radiated measurements, emissions within 2 MHz of the authorized band edge may be measured using the marker-delta method described below. The integration method described below can be used when performing conducted or radiated average measurements.

#### 9.1.1 CONFORMANCE LIMIT

In any 100 kHz bandwidth outside the frequency band in which the spread spectrum or digitally modulated intentional radiator is operating, the radio frequency power that is produced by the intentional radiator shall be at least 20 dB below that in the 100 kHz bandwidth within the band that contains the highest level of the desired power, based on either an RF conducted or a radiated measurement, provided the transmitter demonstrates compliance with the peak conducted power limits. If the transmitter complies with the conducted power limits based on the use of RMS averaging over a time interval, as permitted under paragraph (b)(3) of this section, the attenuation required under this paragraph shall be 30 dB instead of 20 dB.

#### 9.1.2 MEASURING INSTRUMENTS

The Measuring equipment is listed in the section 6.3 of this test report.

#### 9.1.3 MARKER-DELTA METHOD

The marker-delta method, as described in ANSI C63.10, can be used to perform measurements of the radiated unwanted emissions level at the band-edges provided that the 99% OBW of the fundamental emission is within 2 MHz of the authorized band edge.

#### 9.1.4 INTEGRATION METHOD

The following procedures may be used to determine the average power or power density of any unwanted emission. Use the procedure described in 13.3.1 when the EUT can be configured to transmit continuously (i.e., duty cycle  $\geq 98\%$ ). Use the procedure described in 13.3.2 when the EUT cannot be configured to transmit continuously but the duty cycle is constant (i.e., duty cycle variations are less than  $\pm 2$  percent). Use the procedure described in 13.3.3 when the EUT cannot be configured to transmit continuously and the duty cycle is not constant (duty cycle variations equal or exceed 2 percent).

#### 9.1.5 TEST PROCEDURE

If the EUT can be configured or modified to transmit continuously (i.e., duty cycle  $\geq 98$  percent) then the average emission levels within 2 MHz of the authorized band edge may be measured using the following method (with EUT transmitting continuously).

- a) Set instrument center frequency to the frequency of the emission to be measured (must be within 2 MHz of the authorized band edge).
- b) Set span to 2 MHz
- c) RBW = 100 kHz.
- d) VBW  $\geq 3 \times$  RBW.
- e) Detector = RMS, if span/(# of points in sweep)  $\leq$  (RBW/2).
- f) Averaging type = power (i.e., RMS).

- 1) As an alternative, the detector and averaging type may be set for linear voltage averaging.
- 2) Some instruments require linear display mode in order to use linear voltage averaging. Log or dB averaging shall not be used.
- g) Sweep time = auto.
- h) Perform a trace average of at least 100 traces.
- i) Compute the power by integrating the spectrum over 1 MHz using the analyzer's band power measurement function with band limits set equal to the emission frequency ( $f_{\text{emission}} \pm 0.5 \text{ MHz}$ ). If the instrument does not have a band power function, then sum the amplitude levels (in power units) at 100 kHz intervals extending across the 1 MHz spectrum defined by  $f_{\text{emission}} \pm 0.5 \text{ MHz}$ .

#### 9.1.6 DEVIATION FROM STANDARD

No deviation.

#### 9.1.7 TEST SETUP

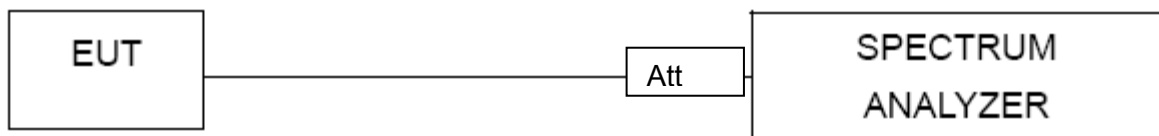

#### 9.1.8 EUT OPERATION CONDITIONS

The EUT tested system was configured as the statements of 2.4 Unless otherwise a special operating condition is specified in the follows during the testing.

### 9.2 TEST RESULTS

EUT :	Alpha Intelligent Robot 2	Model Name :	Alpha 2
Temperature :	25 °C	Relative Humidity :	56%
Pressure :	1012 hPa	Test Voltage :	DC 11.1V

Frequency Band MHz	Delta Avg to band emission (dBc)	> Limit (dBc)	Result
802.11b mode			
2400	43.37	30	Pass
2483.5	60.98	30	Pass
802.11g mode			
2400	38.32	30	Pass
2483.5	47.78	30	Pass
802.11n-HT20 mode			
2400	36.56	30	Pass
2483.5	45.92	30	Pass



802.11b: Band Edge, Right Side

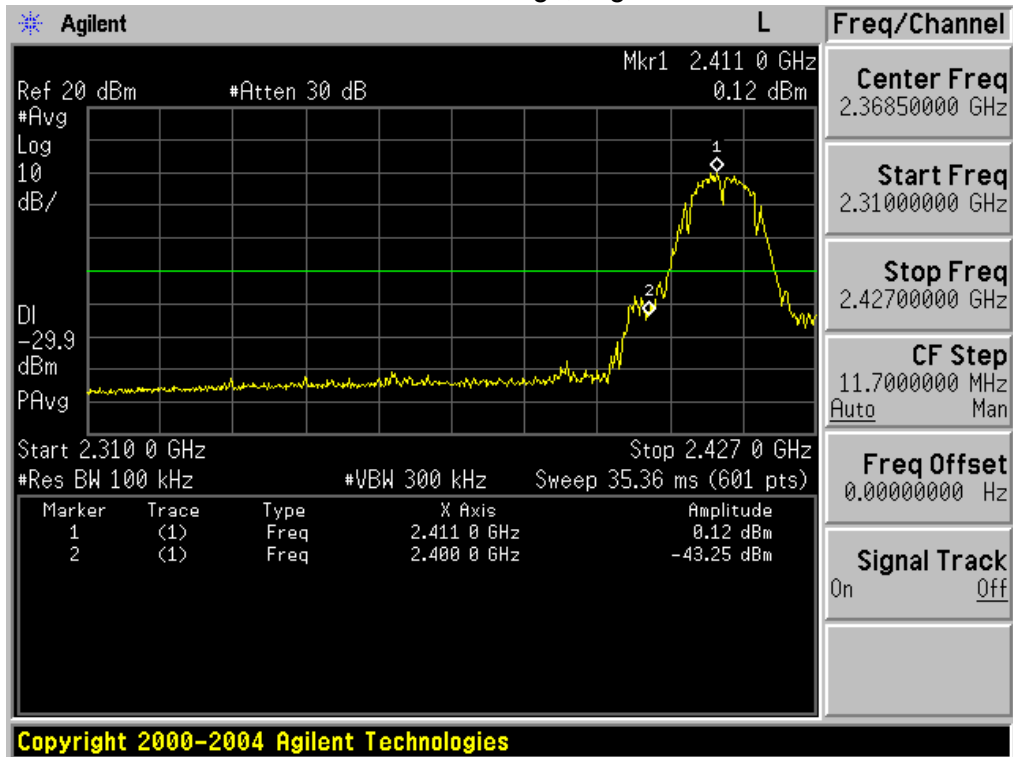

802.11b: Band Edge, Left Side

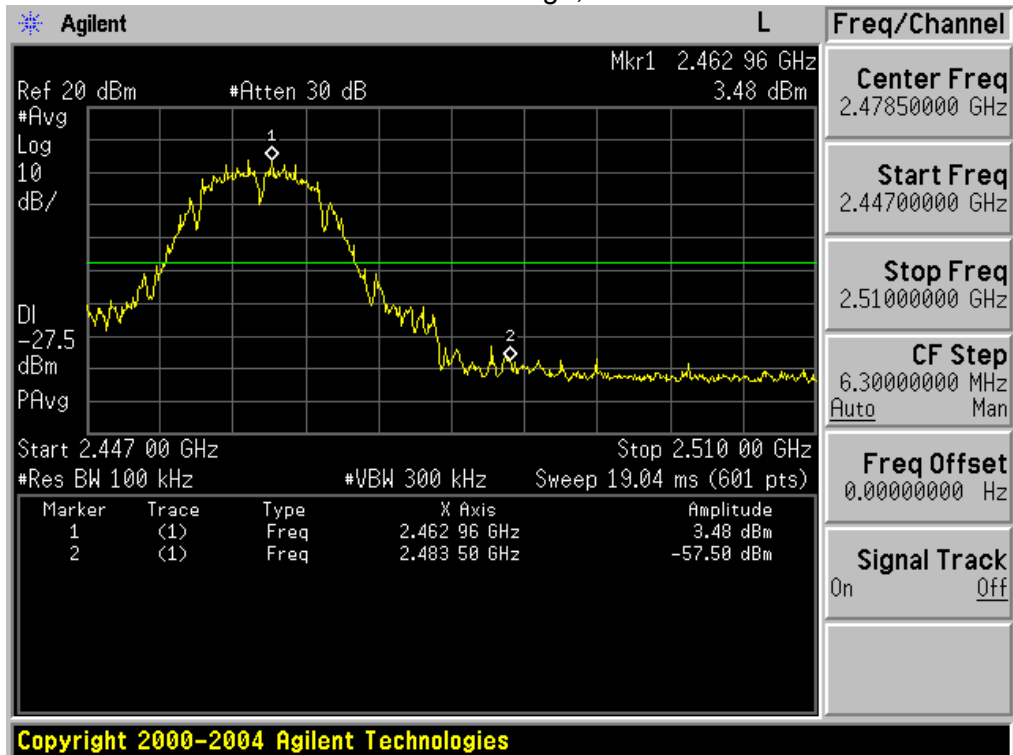

802.11g: Band Edge, Right Side

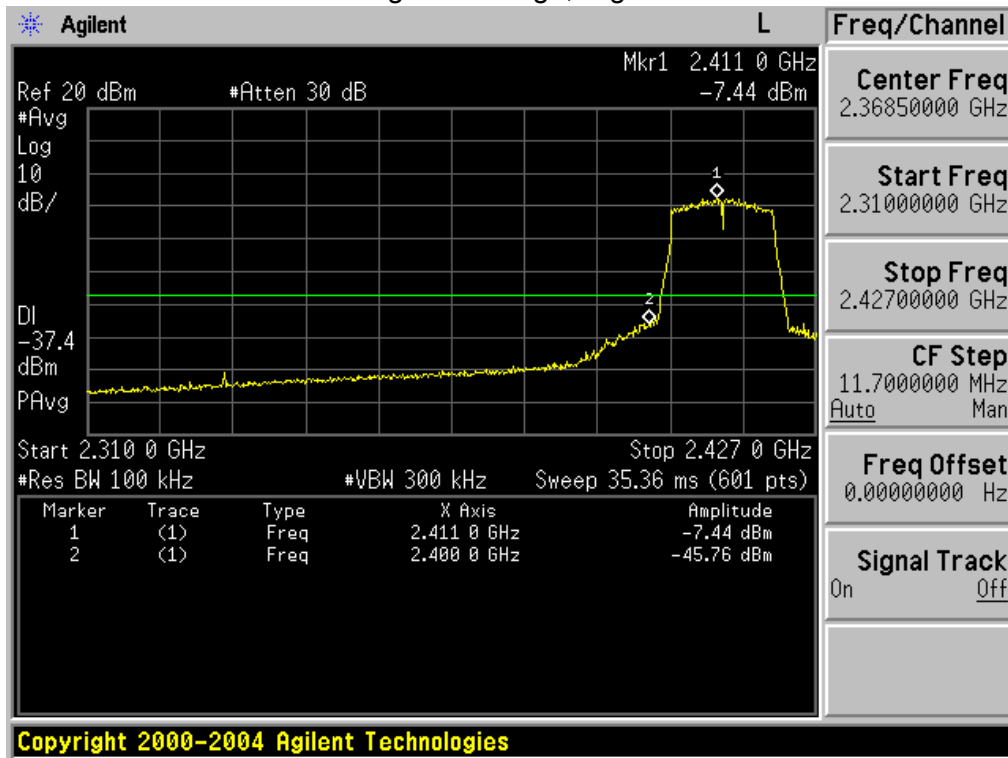

802.11g: Band Edge, Left Side

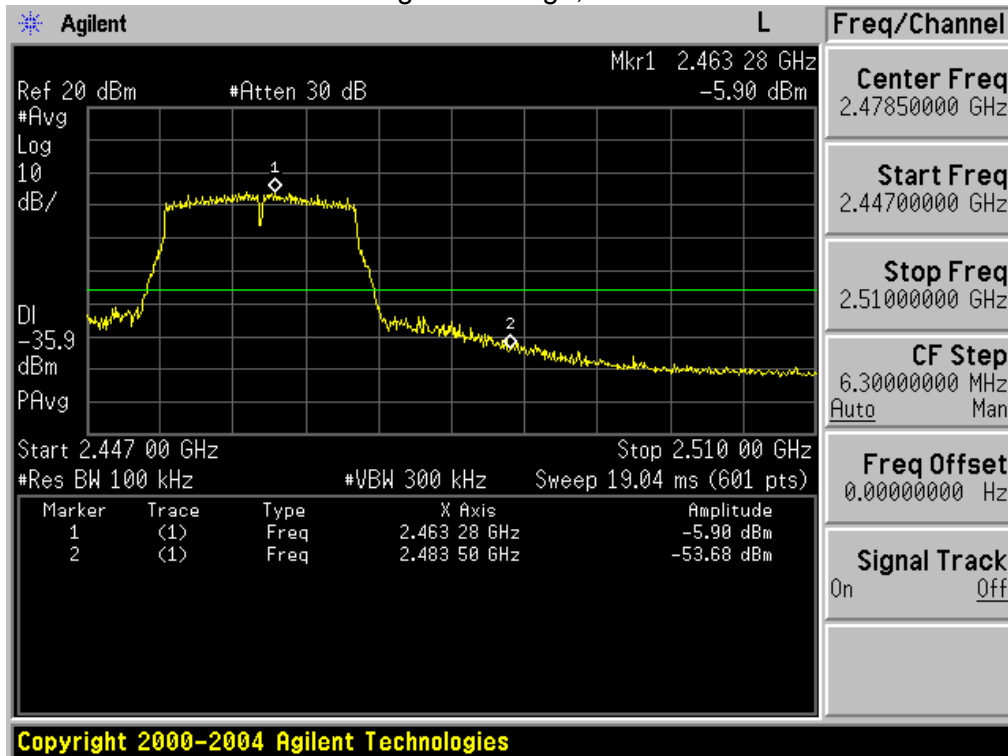

802.11n-HT20: Band Edge, Right Side

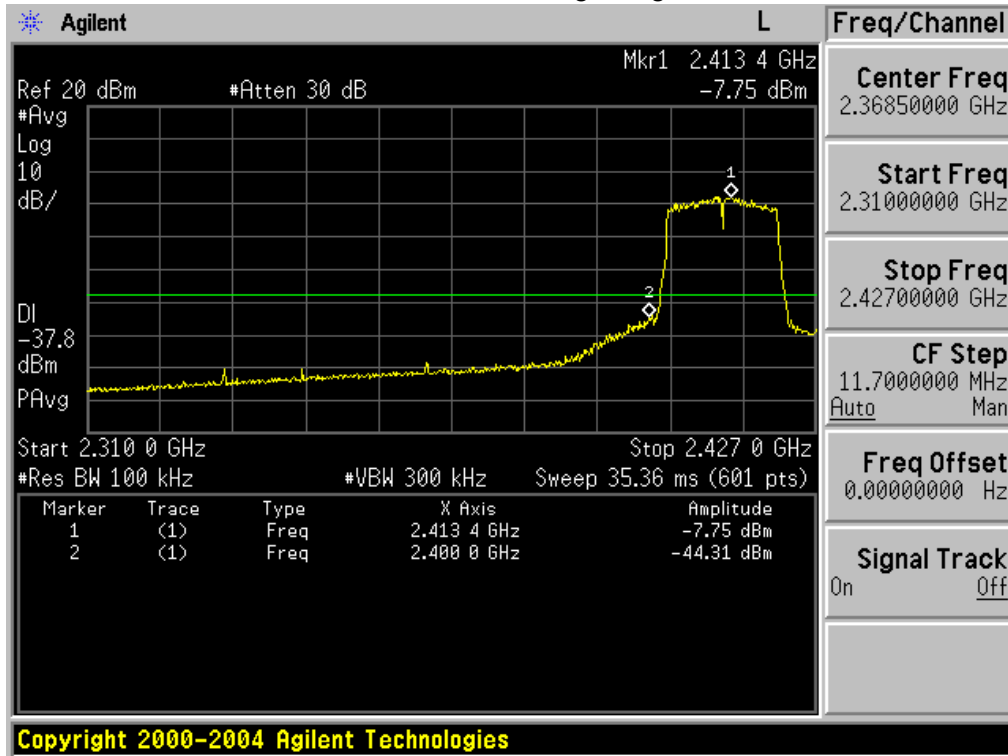

802.11n-HT20: Band Edge, Left Side

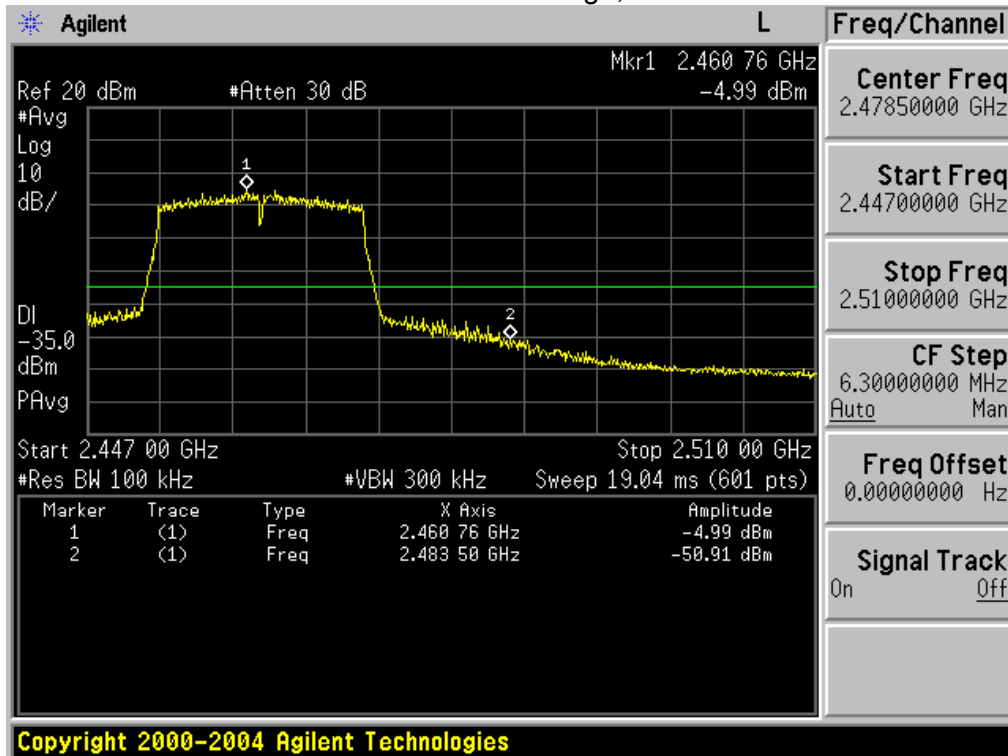

## **10. ANTENNA REQUIREMENT**

### **10.1 STANDARD REQUIREMENT**

15.203 requirement: For intentional device, according to 15.203: an intentional radiator shall be designed to ensure that no antenna other than that furnished by the responsible party shall be used with the device.

### **10.2 EUT ANTENNA**

The EUT antenna is permanent attached antenna. It comply with the standard requirement.

**11. EUT TEST PHOTO**

**Radiated Measurement Photos**

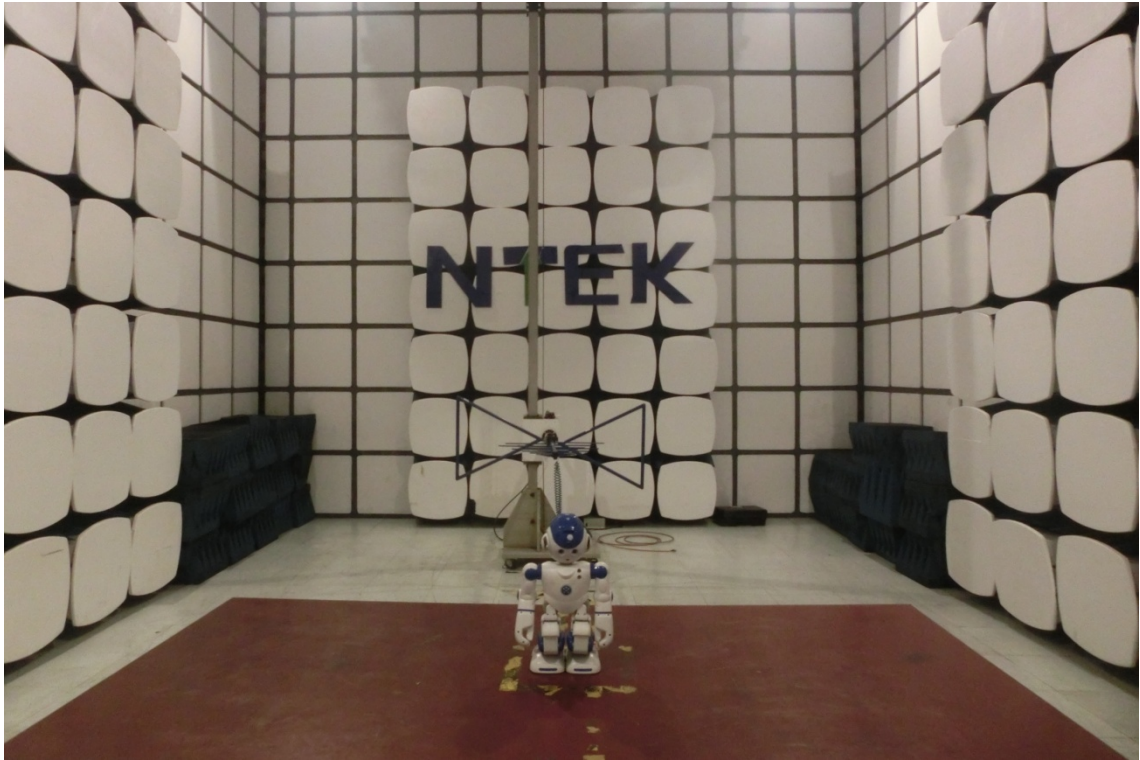

**CONDUCTED EMISSION Photos**

