

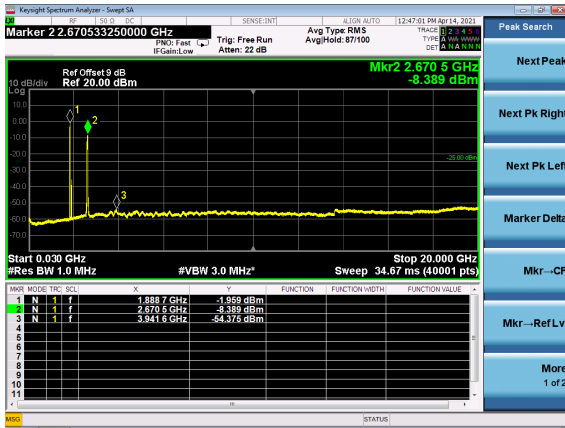

B2_N41(40M)_DFT-s-OFDM_BPSK_Edge_1RB_Left_High_CH

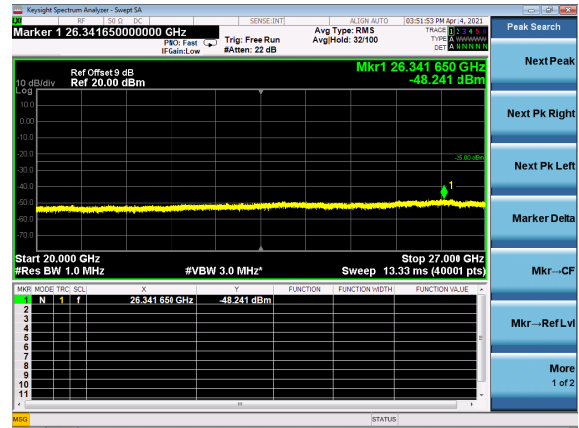

B2_N41(40M)_DFT-s-OFDM_BPSK_Edge_1RB_Left_High_CH



B2_N41(40M)_DFT-s-OFDM_QPSK_Edge_1RB_Left_High_CH

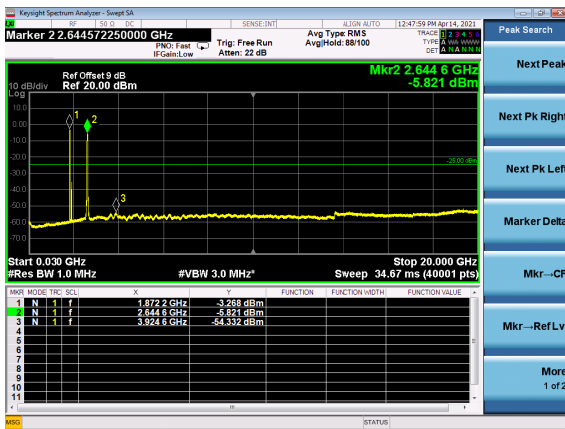

B2_N41(40M)_DFT-s-OFDM_QPSK_Edge_1RB_Left_High_CH

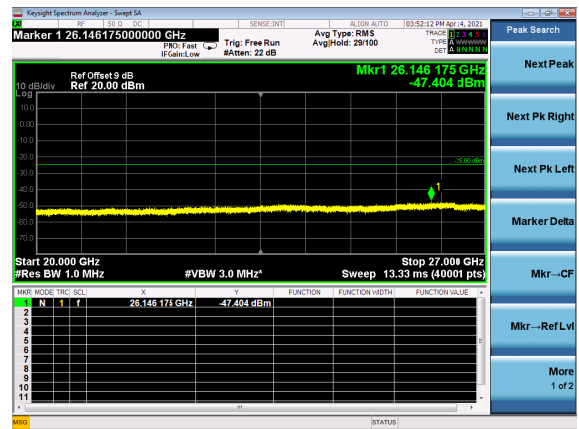

B2_N41(40M)_DFT-s-OFDM_BPSK_Edge_1RB_Left_Mid_CH

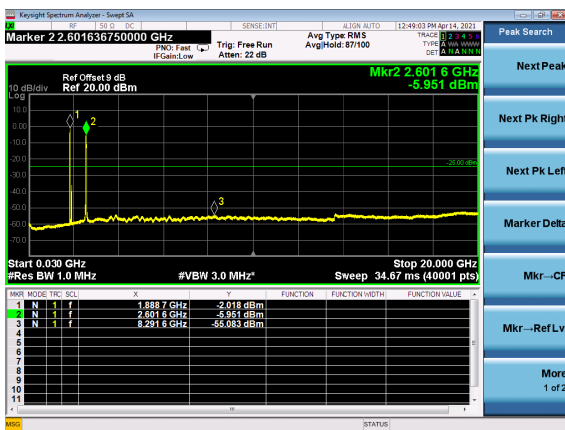

B2_N41(40M)_DFT-s-OFDM_BPSK_Edge_1RB_Left_Mid_CH

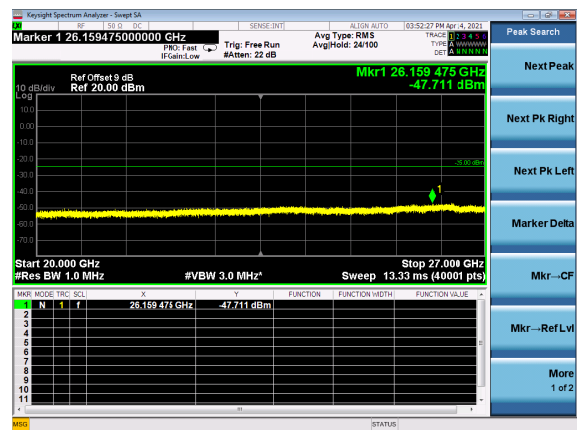

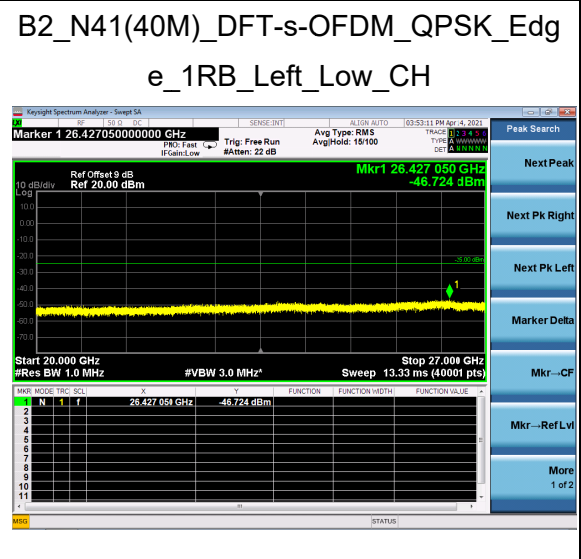
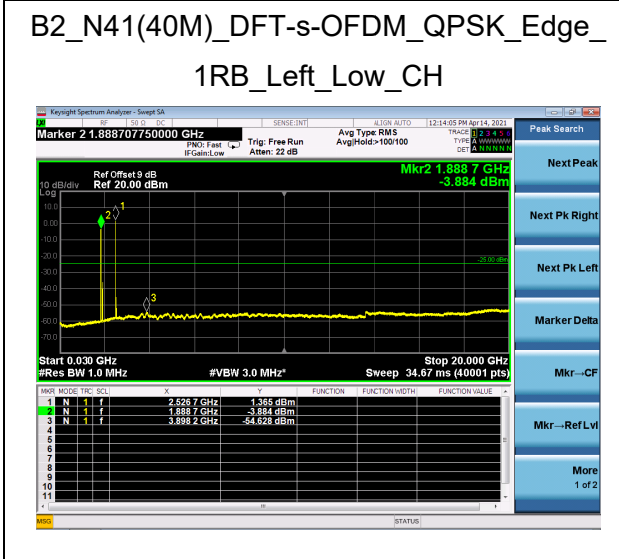
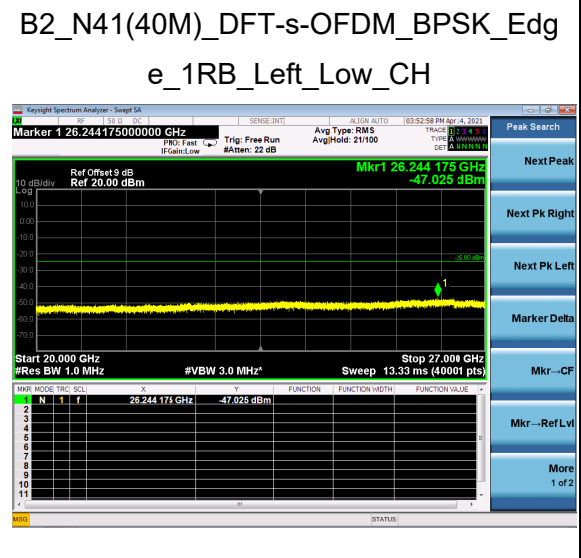
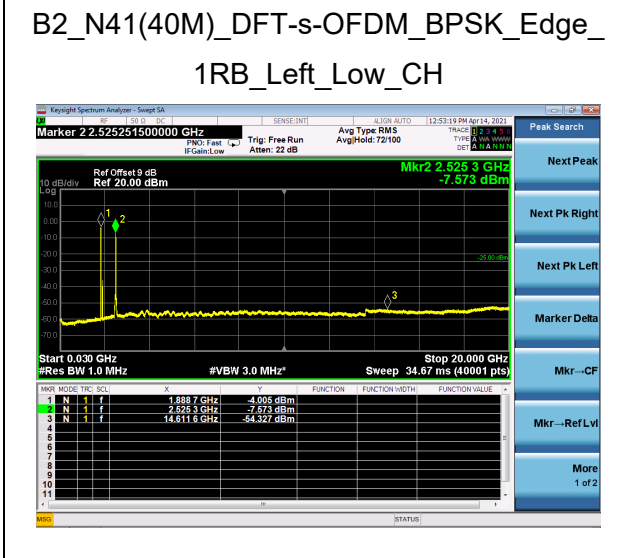
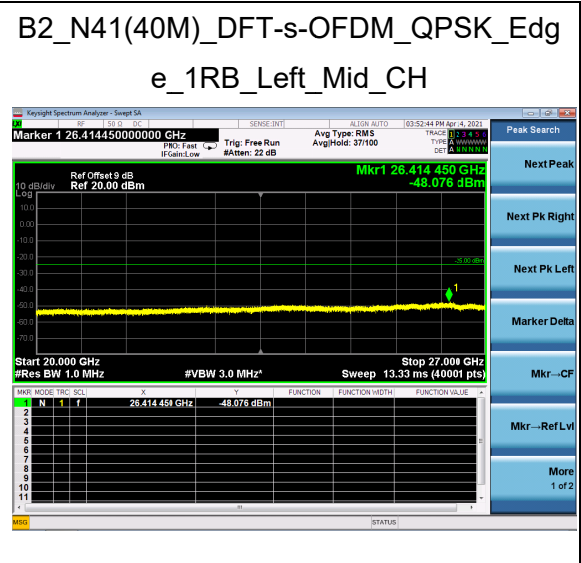
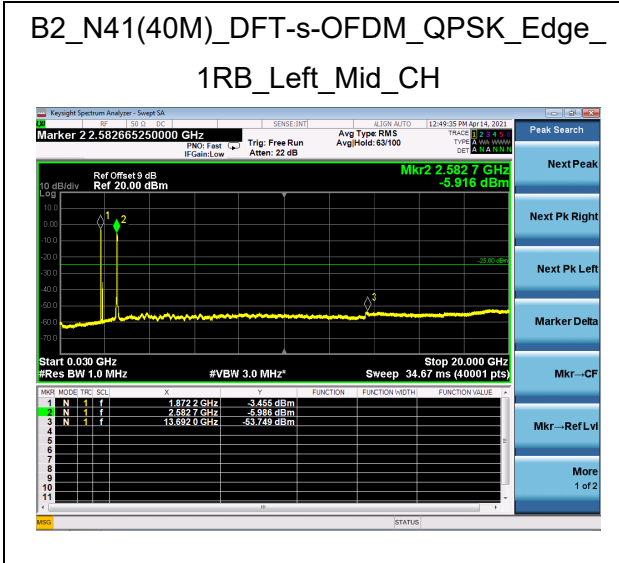



B2_N41(50M)_DFT-s-OFDM_BPSK_Edge_1
RB_Left_High_CH

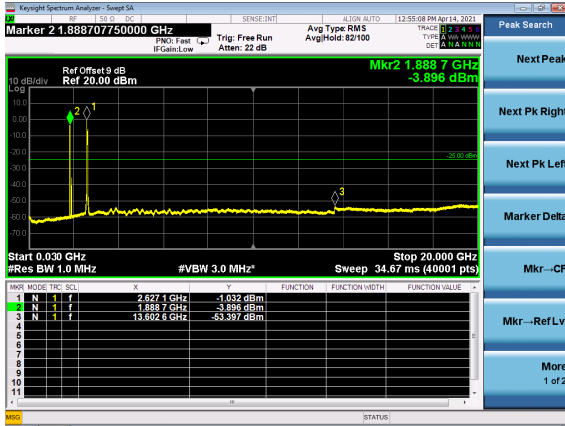

B2_N41(50M)_DFT-s-OFDM_BPSK_Edg
e_1RB_Left_High_CH

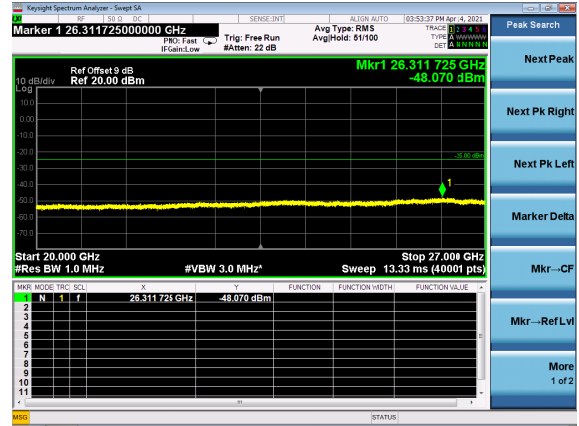

B2_N41(50M)_DFT-s-OFDM_QPSK_Edge_
1RB_Left_High_CH

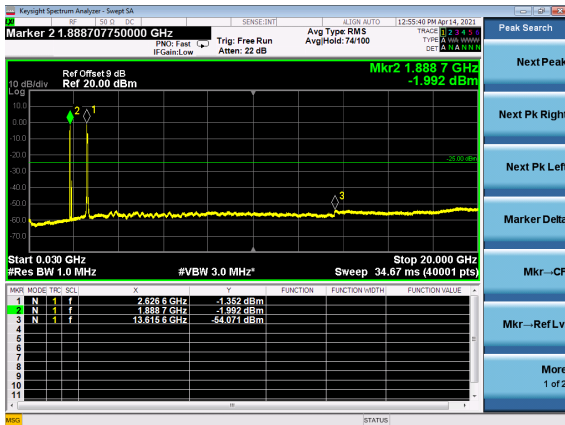

B2_N41(50M)_DFT-s-OFDM_QPSK_Edg
e_1RB_Left_High_CH

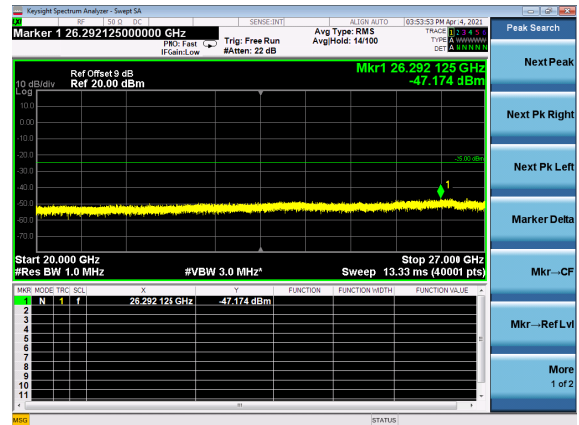

B2_N41(50M)_DFT-s-OFDM_BPSK_Edge_
1RB_Left_Mid_CH

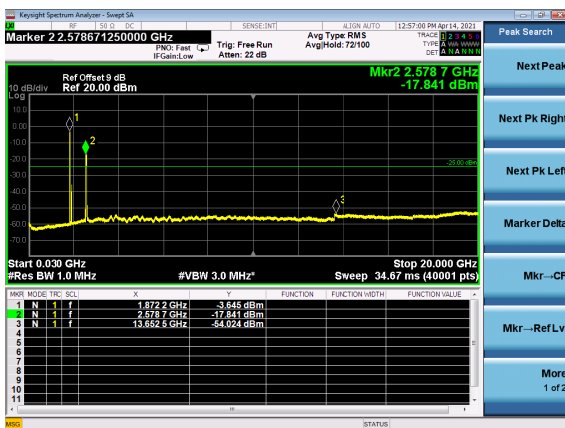

B2_N41(50M)_DFT-s-OFDM_BPSK_Edg
e_1RB_Left_Mid_CH

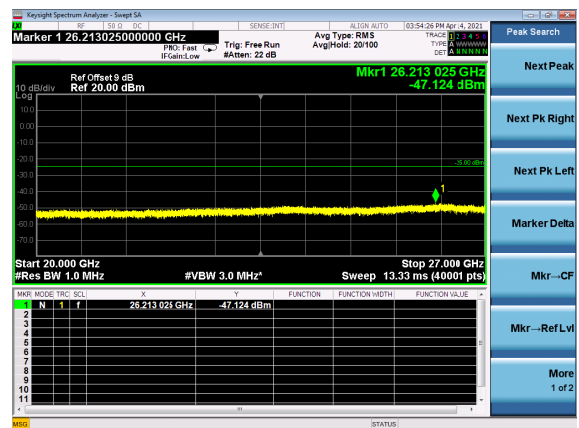

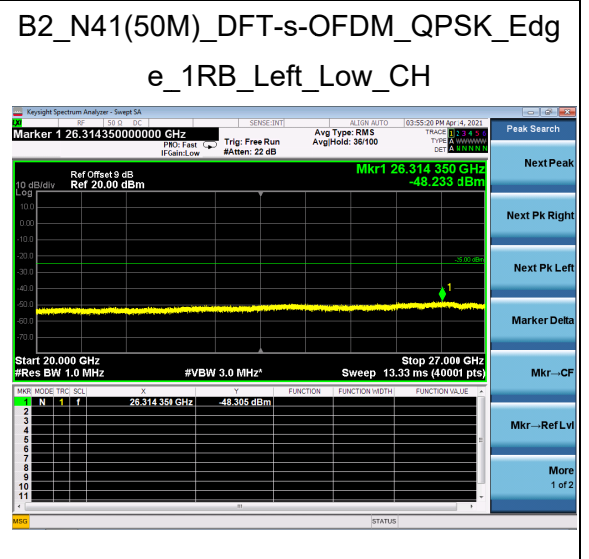
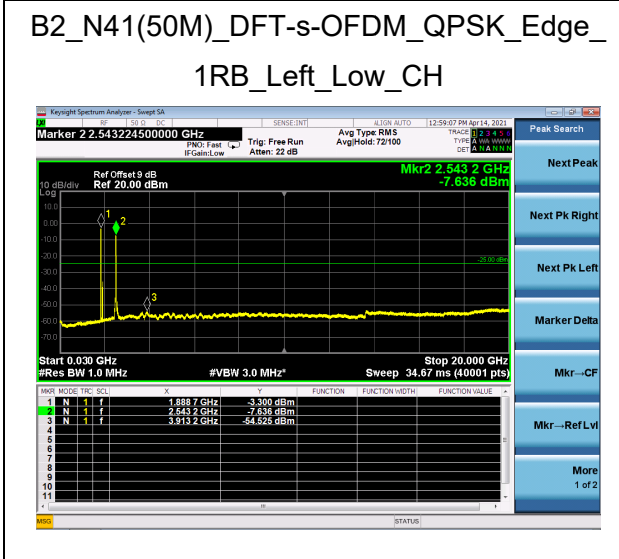
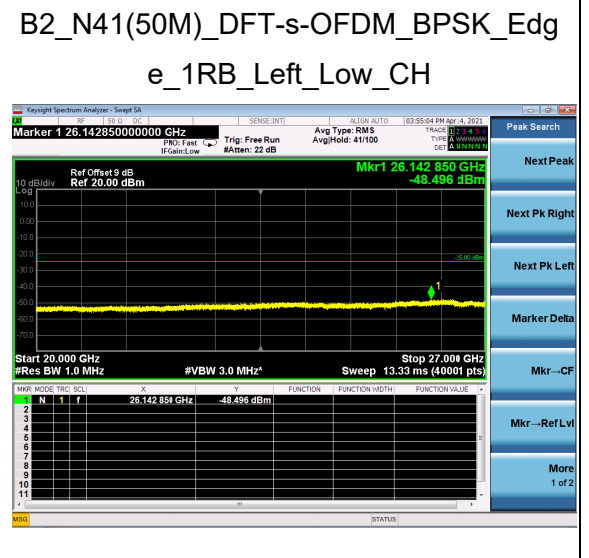
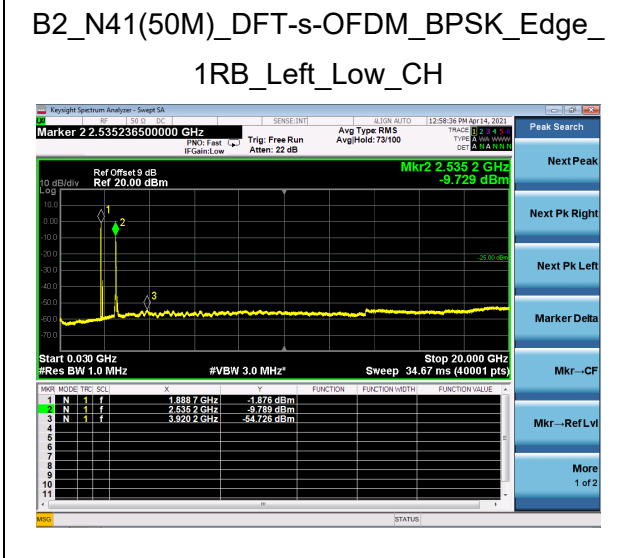
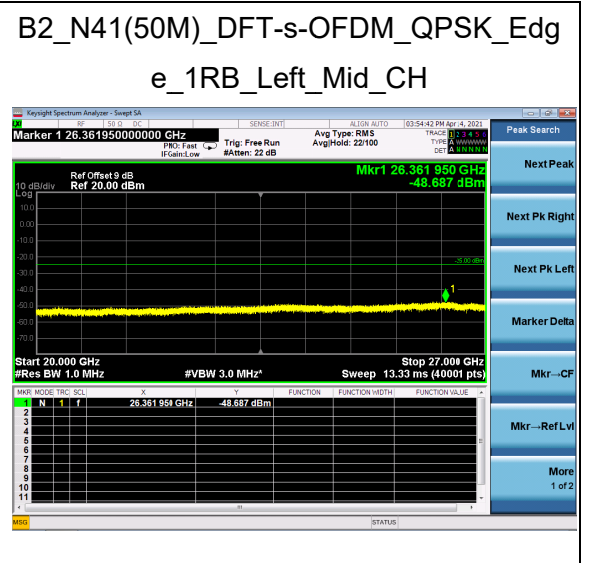
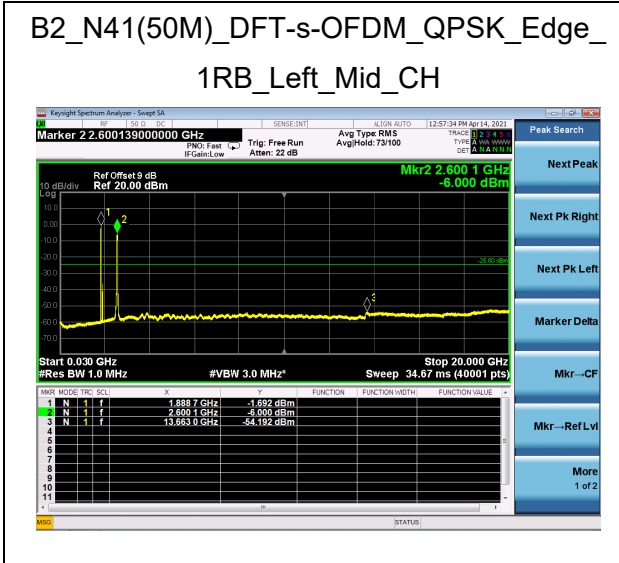



B2_N41(60M)_DFT-s-OFDM_BPSK_Edge_1RB_Left_High_CH

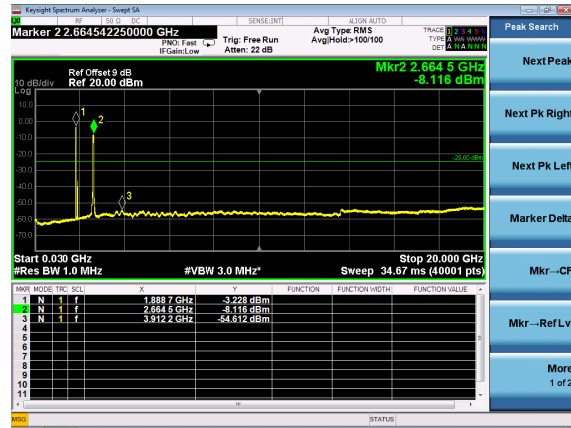

B2_N41(60M)_DFT-s-OFDM_BPSK_Edge_1RB_Left_High_CH

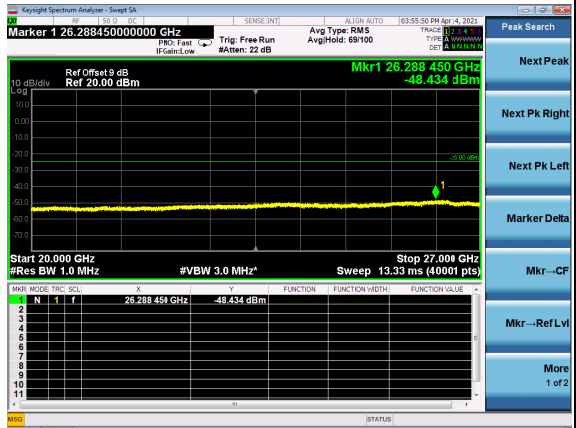

B2_N41(60M)_DFT-s-OFDM_QPSK_Edge_1RB_Left_High_CH

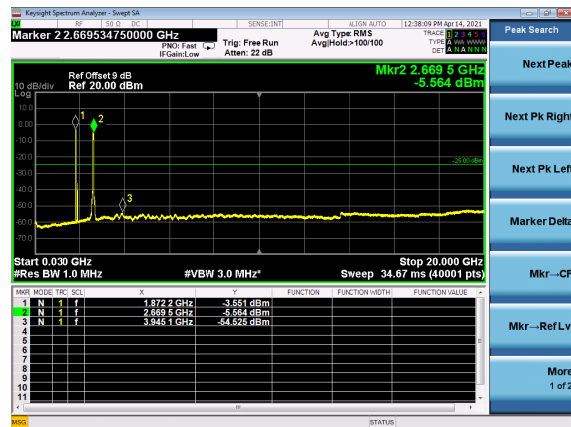

B2_N41(60M)_DFT-s-OFDM_QPSK_Edge_1RB_Left_High_CH

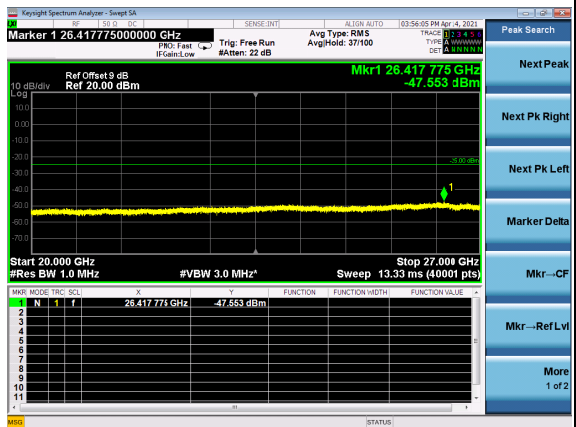

B2_N41(60M)_DFT-s-OFDM_BPSK_Edge_1RB_Left_Mid_CH

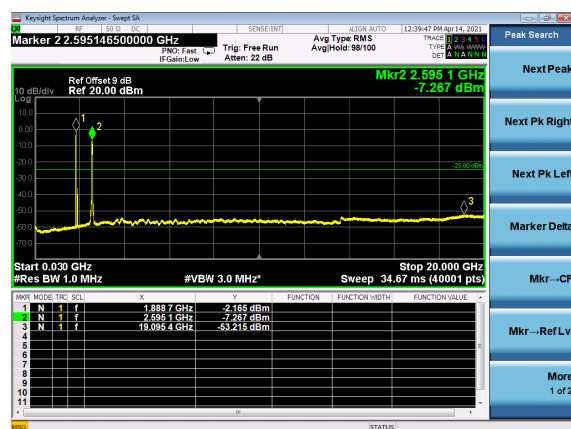

B2_N41(60M)_DFT-s-OFDM_BPSK_Edge_1RB_Left_Mid_CH

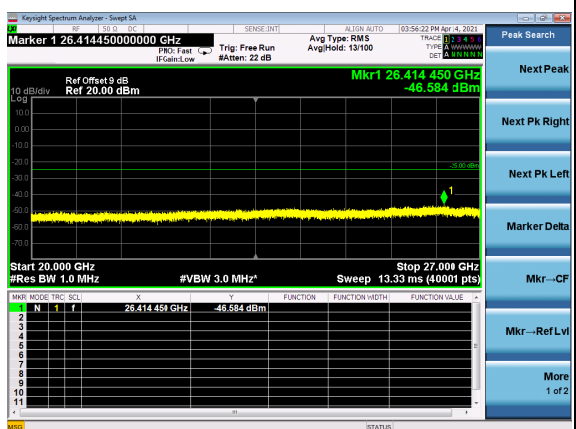



B2_N41(60M)_DFT-s-OFDM_QPSK_Edge_1
RB_Left_Mid_CH

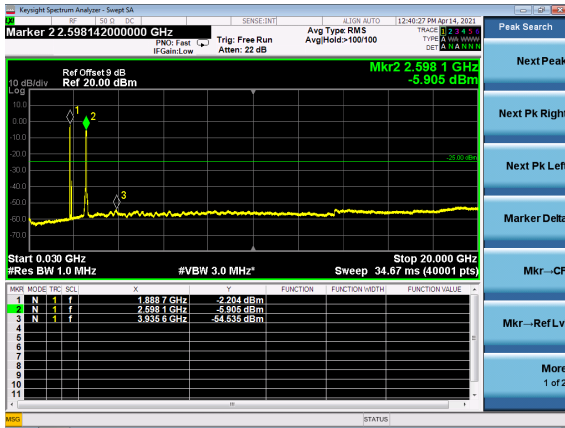

B2_N41(60M)_DFT-s-OFDM_QPSK_Edg
e_1RB_Left_Mid_CH

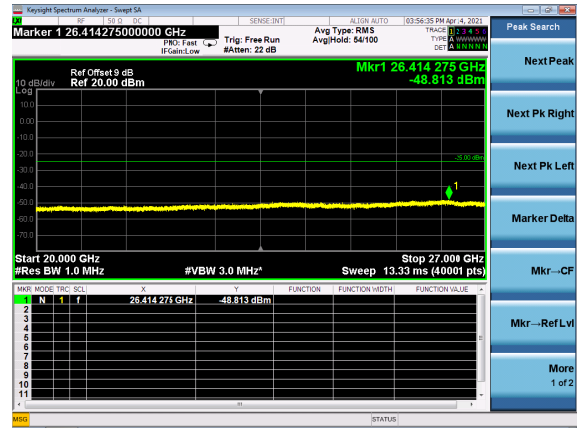

B2_N41(60M)_DFT-s-OFDM_BPSK_Edge_
1RB_Left_Low_CH

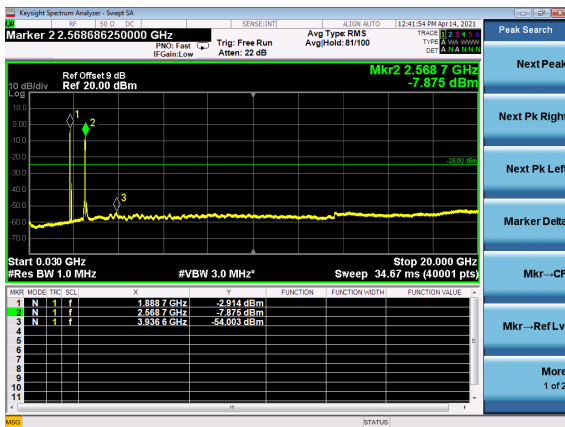

B2_N41(60M)_DFT-s-OFDM_BPSK_Edg
e_1RB_Left_Low_CH

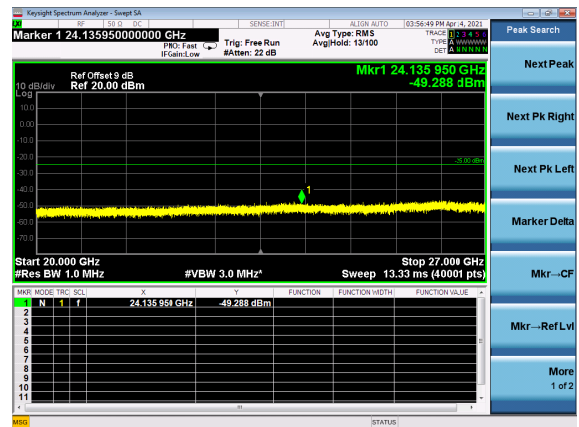

B2_N41(60M)_DFT-s-OFDM_QPSK_Edge_
1RB_Left_Low_CH

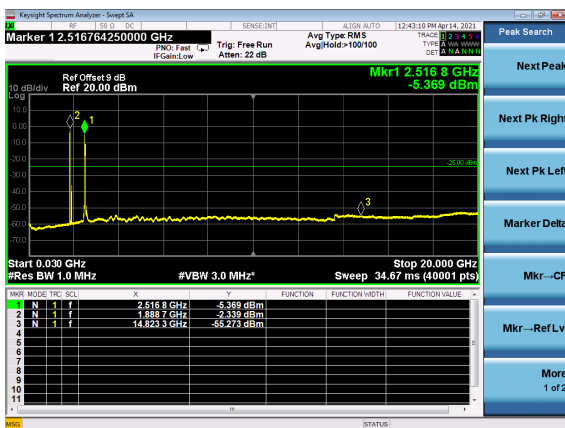

B2_N41(60M)_DFT-s-OFDM_QPSK_Edg
e_1RB_Left_Low_CH

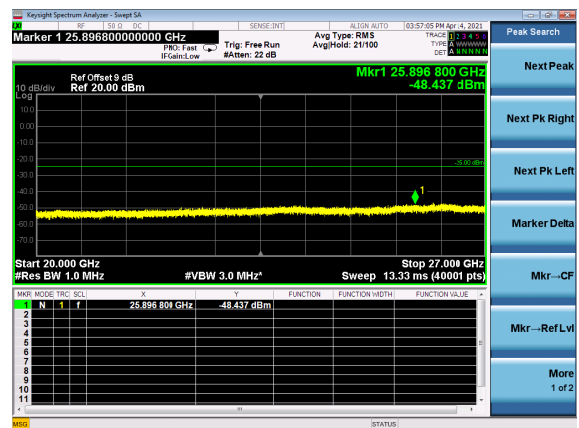

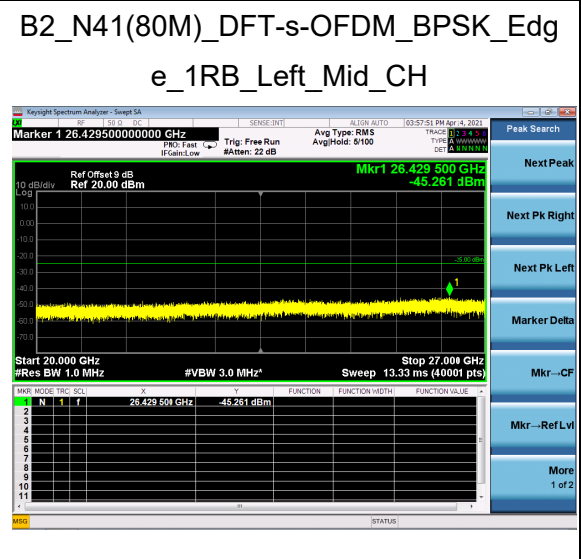
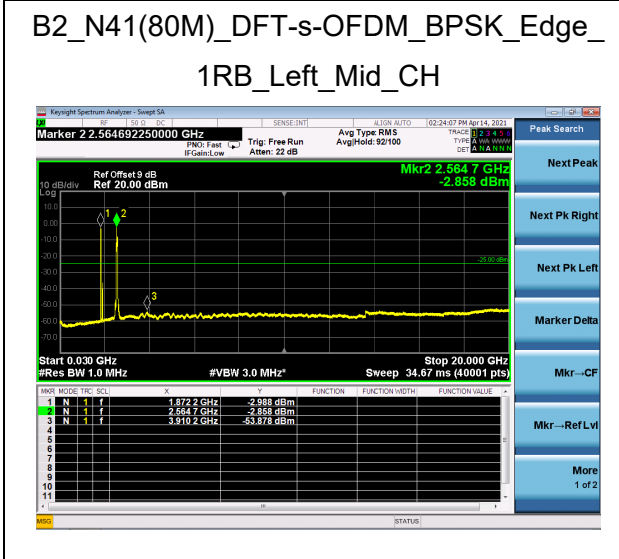
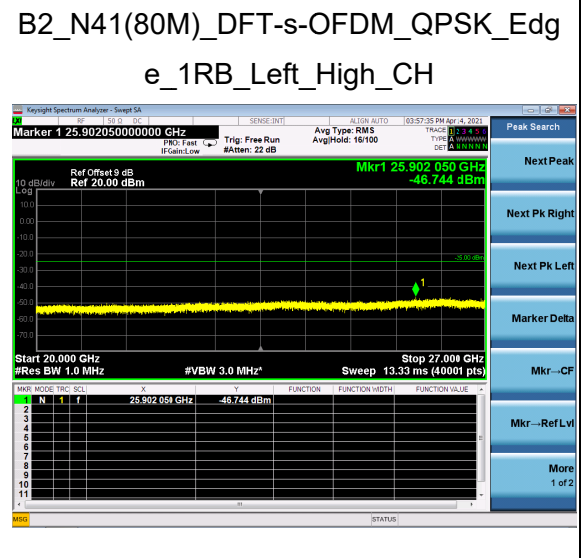
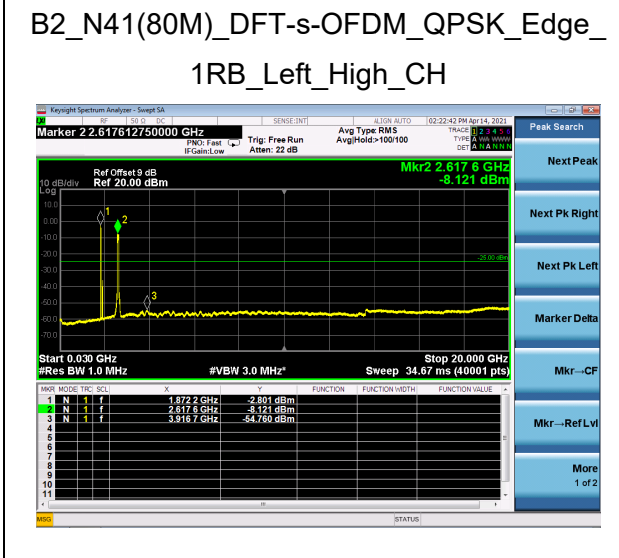
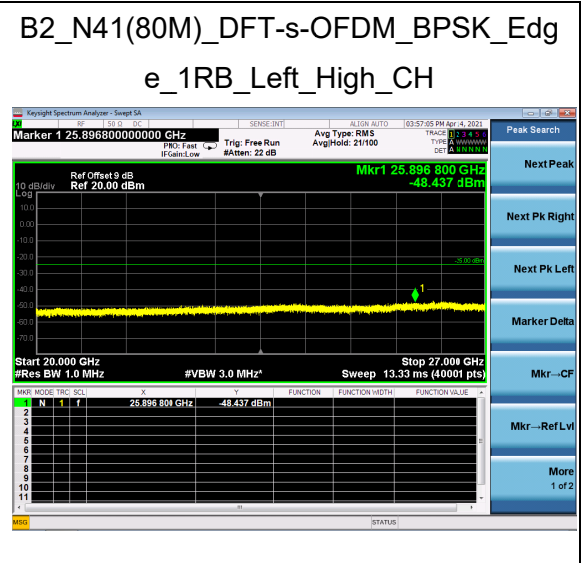
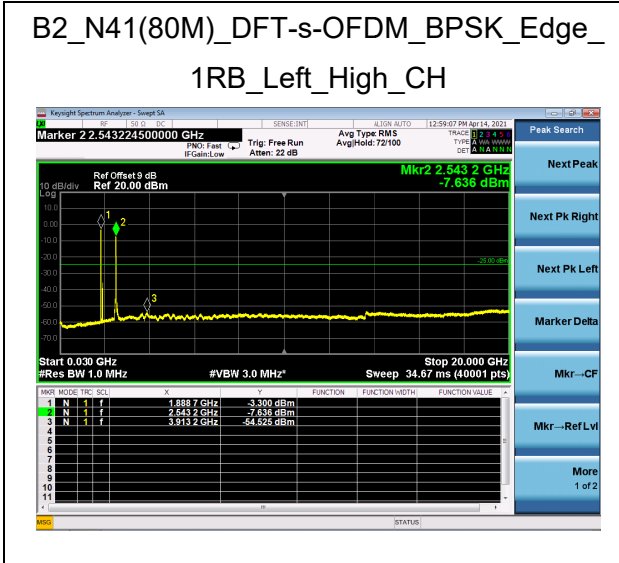

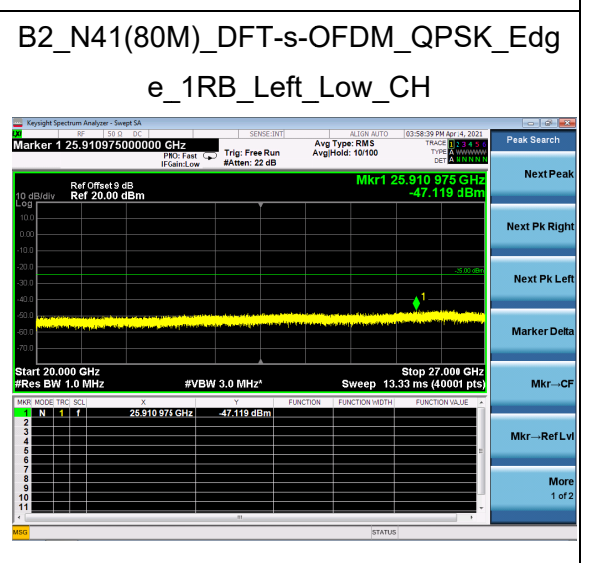
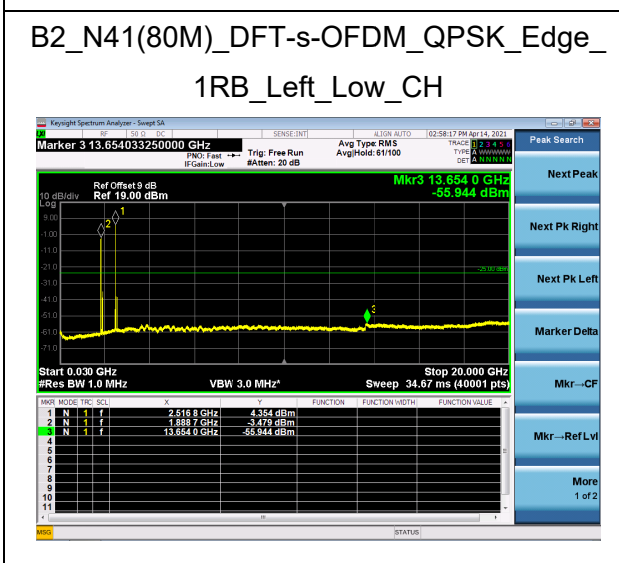
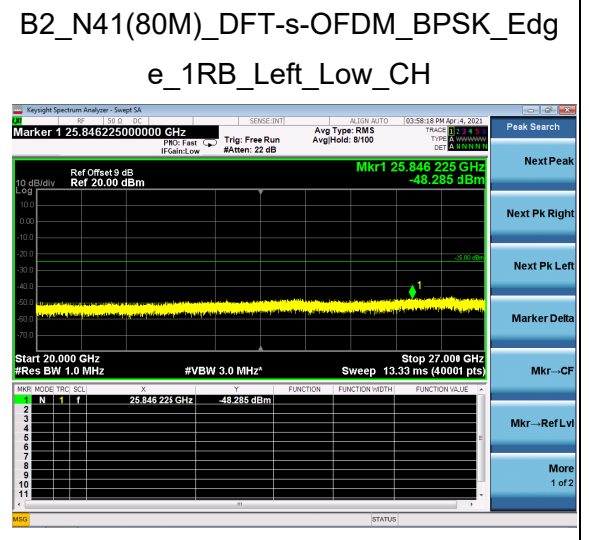
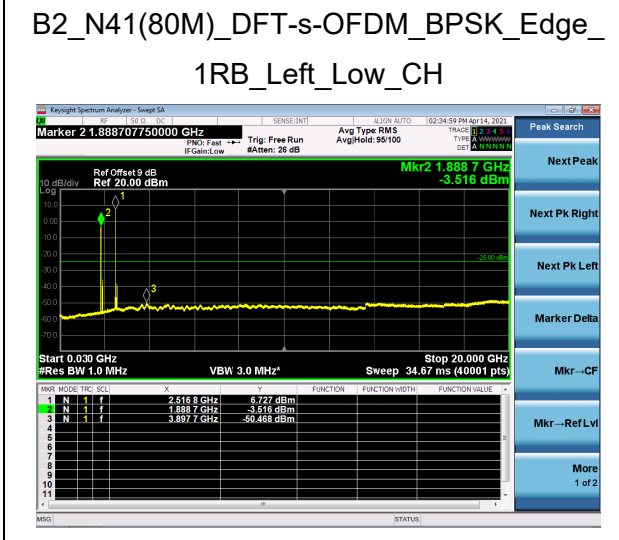
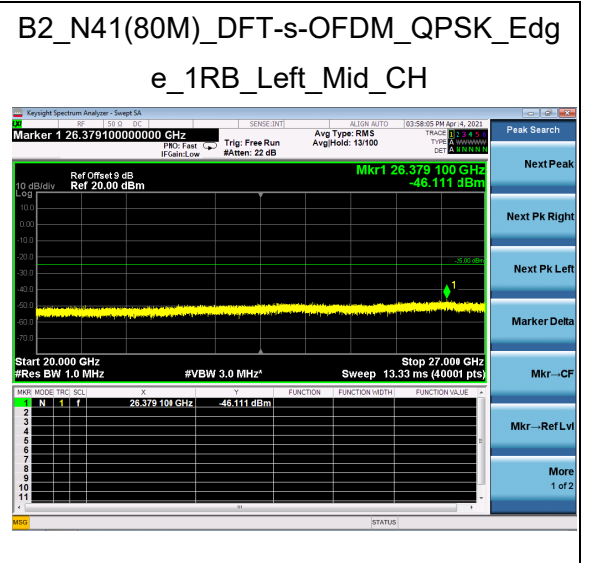
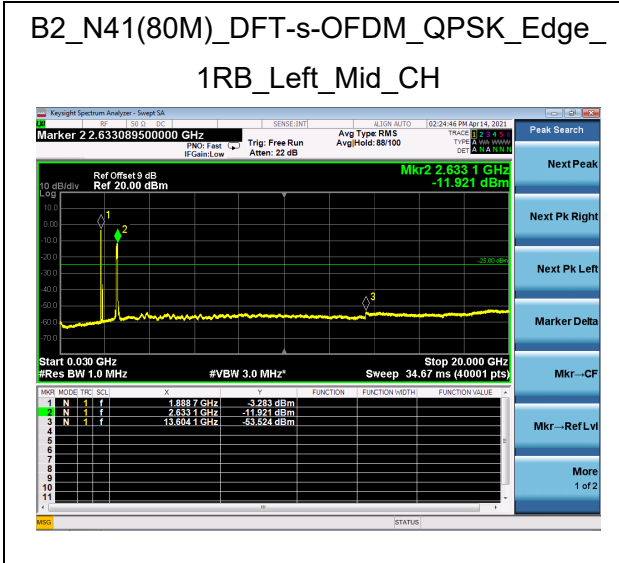



B2_N41(90M)_DFT-s-OFDM_BPSK_Edge_1
RB_Left_High_CH

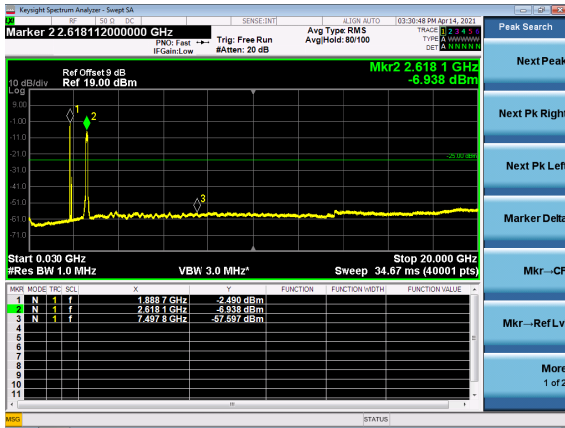

B2_N41(90M)_DFT-s-OFDM_BPSK_Edg
e_1RB_Left_High_CH

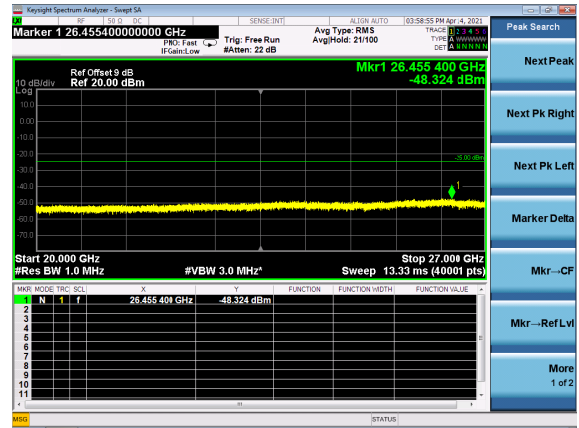

B2_N41(90M)_DFT-s-OFDM_QPSK_Edge_
1RB_Left_High_CH

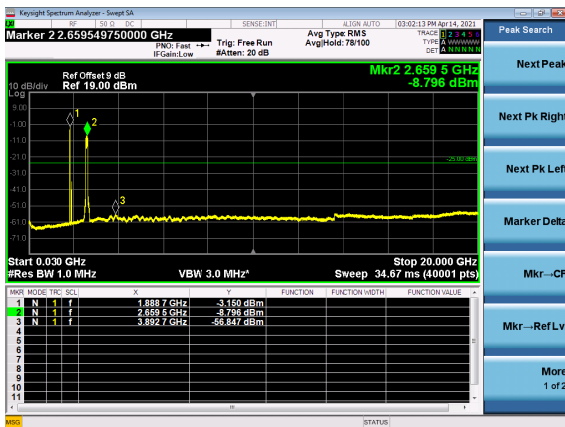

B2_N41(90M)_DFT-s-OFDM_QPSK_Edg
e_1RB_Left_High_CH

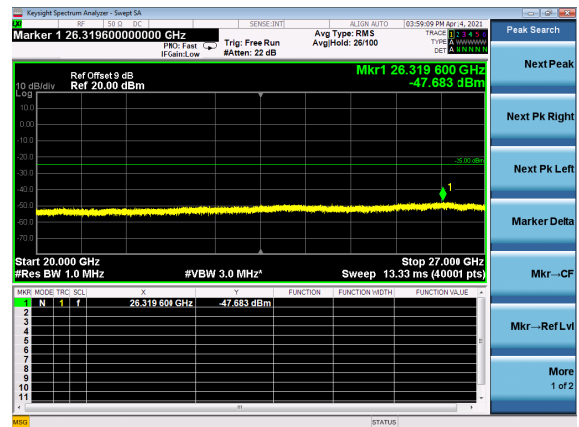

B2_N41(90M)_DFT-s-OFDM_BPSK_Edge_
1RB_Left_Mid_CH

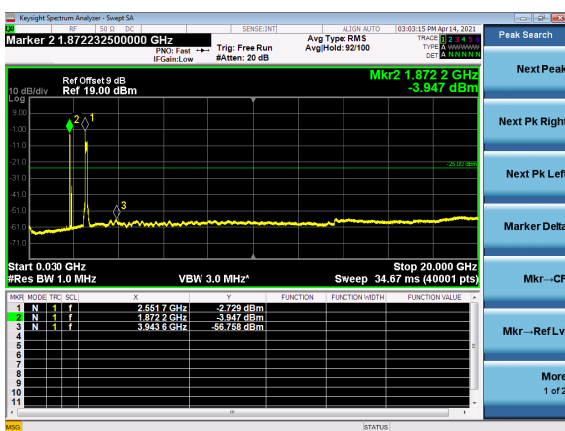

B2_N41(90M)_DFT-s-OFDM_BPSK_Edg
e_1RB_Left_Mid_CH

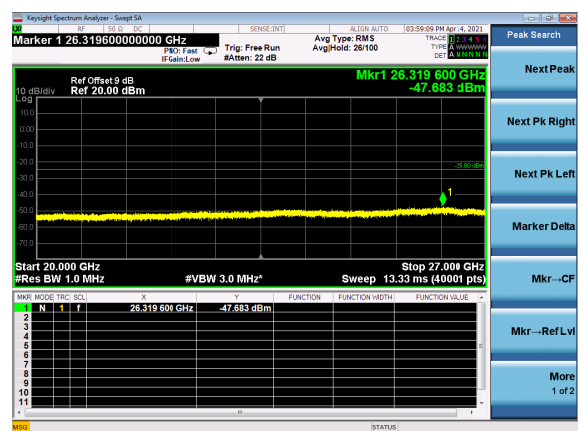

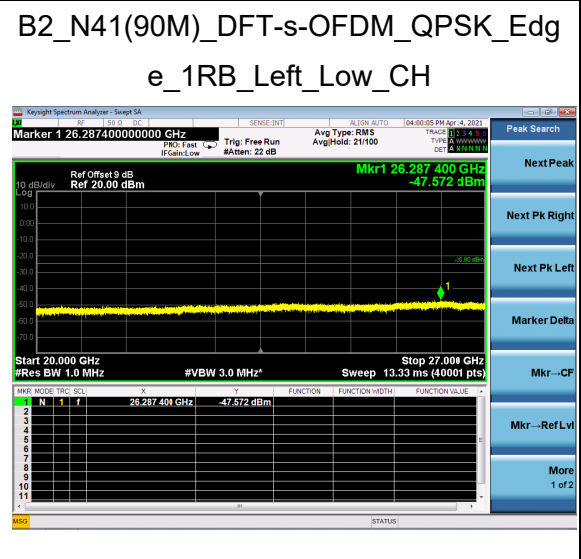
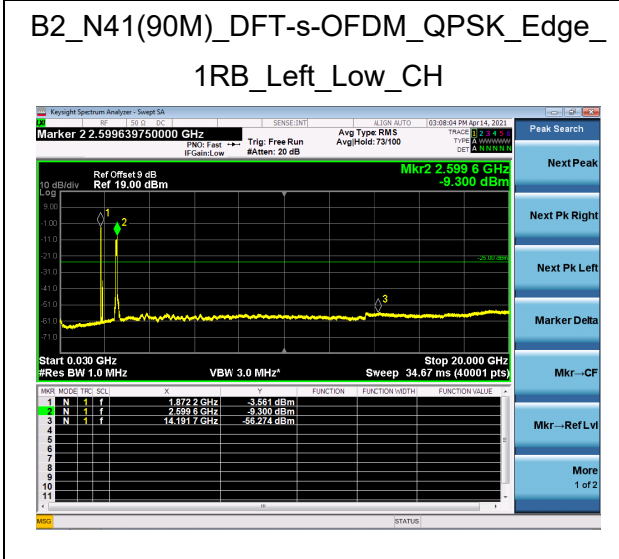
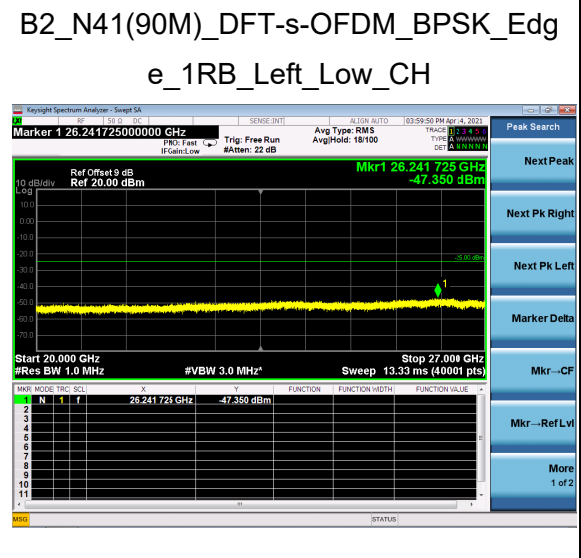
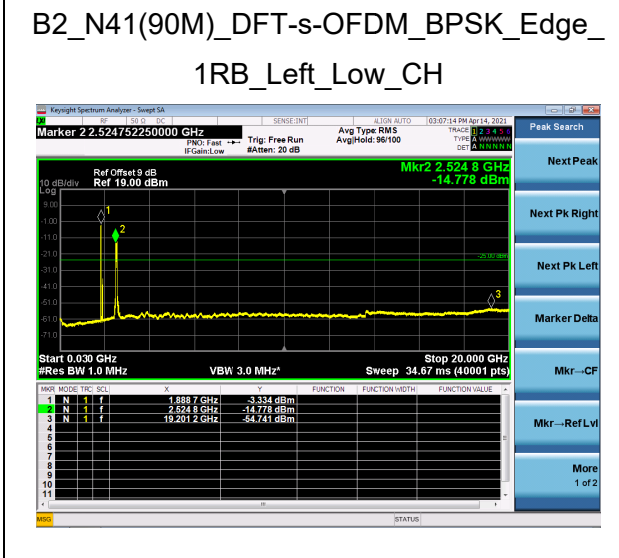
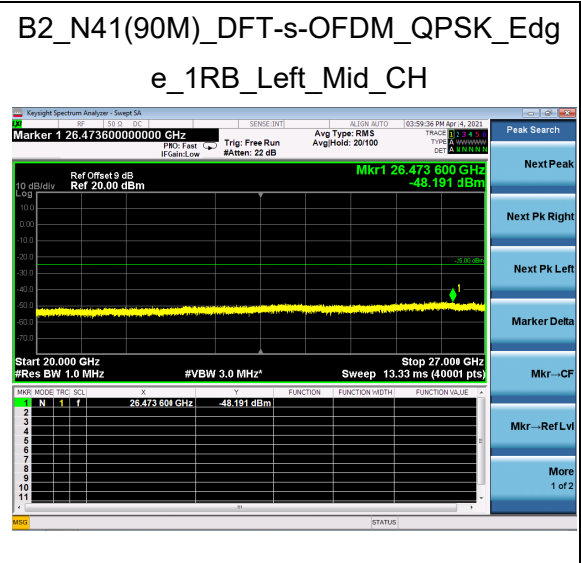
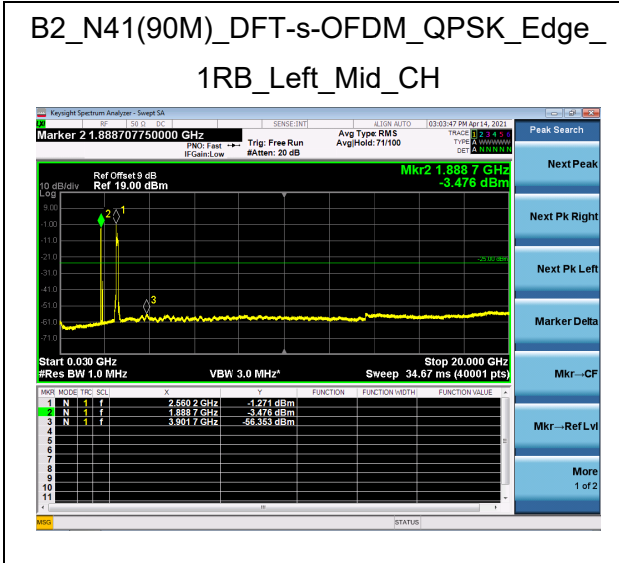



B2_N41(100M)_DFT-s-OFDM_BPSK_Edge_1RB_Left_High_CH

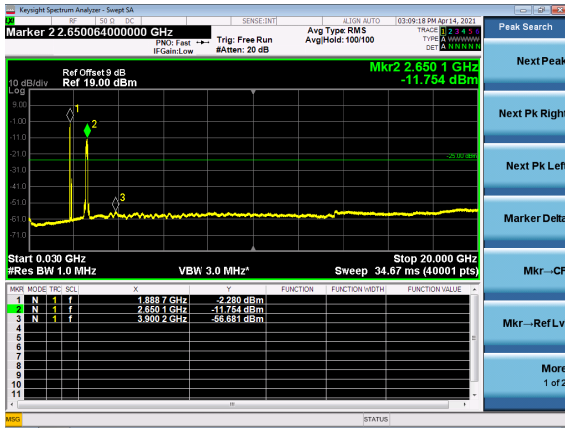

B2_N41(100M)_DFT-s-OFDM_BPSK_Edge_1RB_Left_High_CH

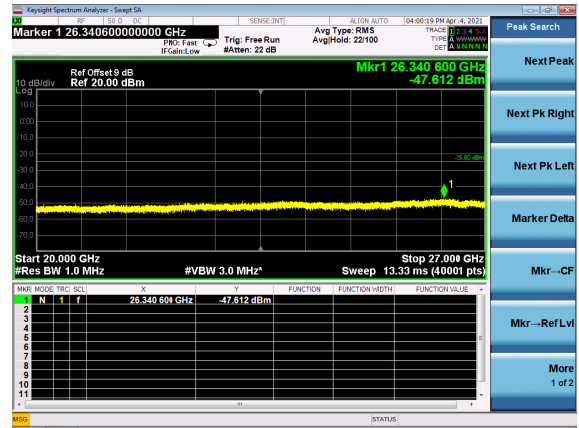

B2_N41(100M)_DFT-s-OFDM_QPSK_Edge_1RB_Left_High_CH

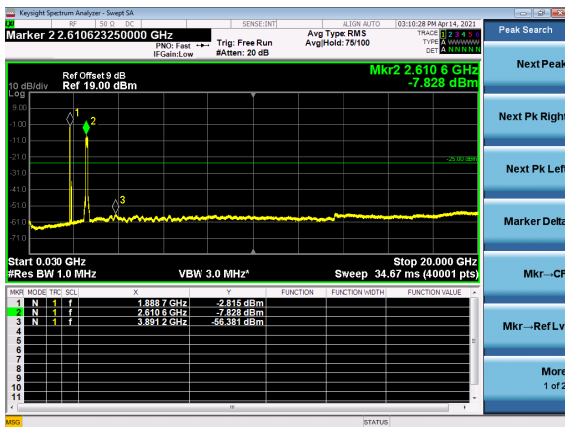

B2_N41(100M)_DFT-s-OFDM_QPSK_Edge_1RB_Left_High_CH

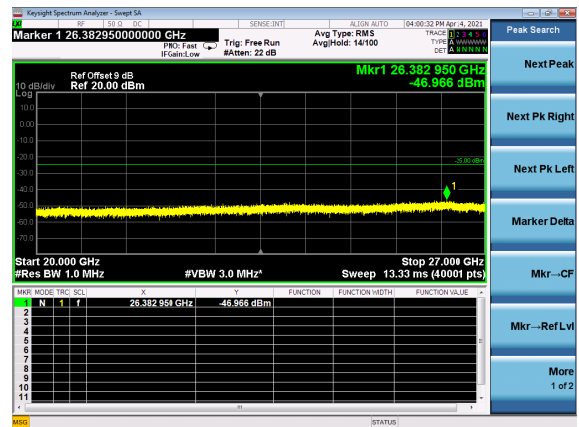

B2_N41(100M)_DFT-s-OFDM_BPSK_Edge_1RB_Left_Mid_CH

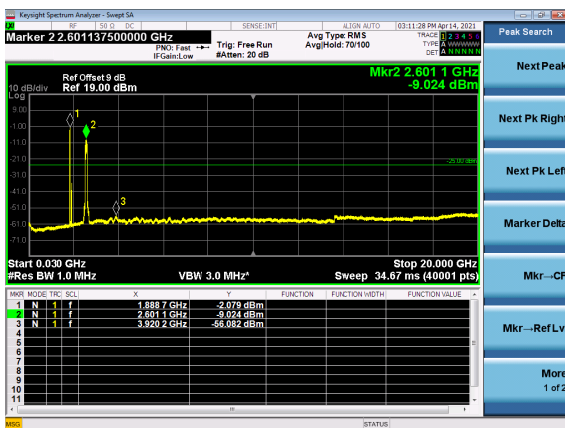

B2_N41(100M)_DFT-s-OFDM_BPSK_Edge_1RB_Left_Mid_CH

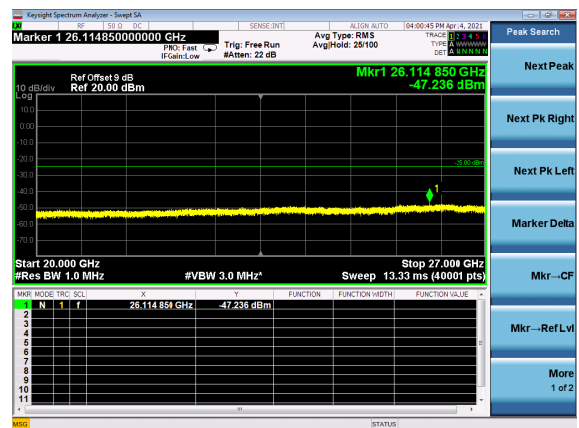



B2_N41(100M)_DFT-s-OFDM_QPSK_Edge_1RB_Left_Mid_CH

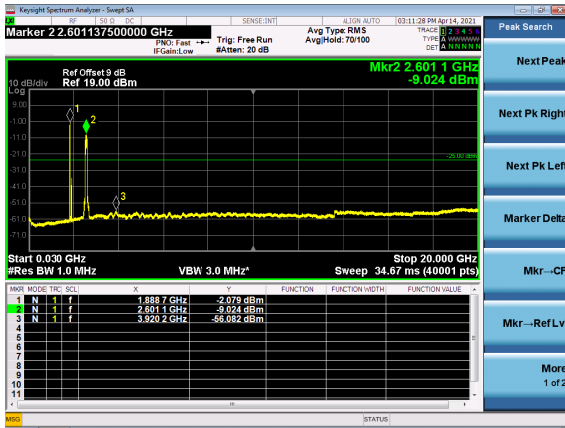

B2_N41(100M)_DFT-s-OFDM_QPSK_Edge_1RB_Left_Mid_CH

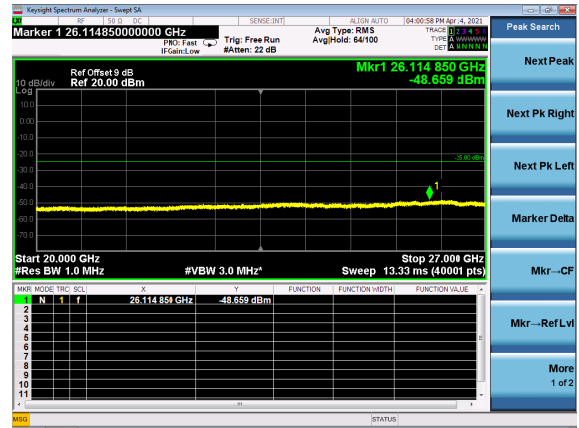

B2_N41(100M)_DFT-s-OFDM_BPSK_Edge_1RB_Left_Low_CH

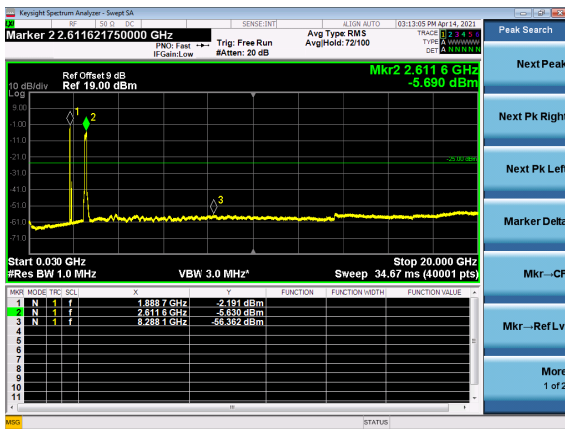

B2_N41(100M)_DFT-s-OFDM_BPSK_Edge_1RB_Left_Low_CH

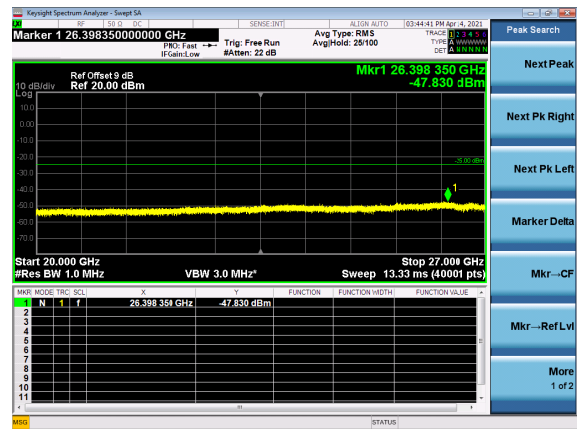

B2_N41(100M)_DFT-s-OFDM_QPSK_Edge_1RB_Left_Low_CH

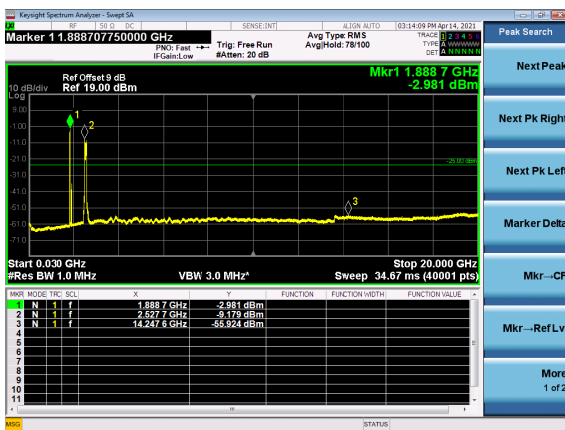

B2_N41(100M)_DFT-s-OFDM_QPSK_Edge_1RB_Left_Low_CH

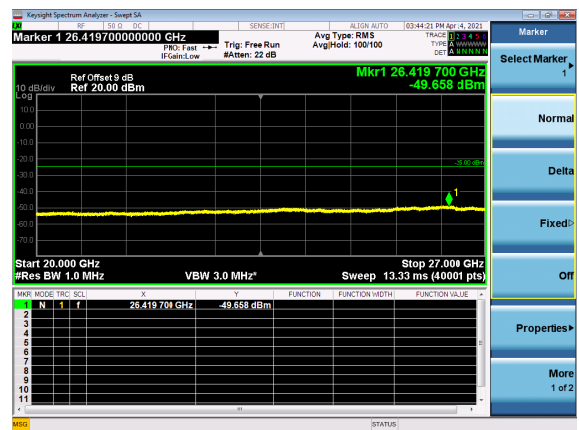



2.5. Band Edge

2.5.1. Requirement

According to FCC section 22.917(a), the power of any emission outside of the authorized operating frequency ranges must be attenuated below the transmitting power (P) by a factor of at least $43 + 10 \log(P)$ dB.

N41

According to FCC section 27.53(m) (4), for mobile digital stations, the attenuation factor shall be not less than $40 + 10 \log(P)$ dB on all frequencies between the channel edge and 5 megahertz from the channel edge, $43 + 10 \log(P)$ dB on all frequencies between 5 megahertz and X megahertz from the channel edge, and $55 + 10 \log(P)$ dB on all frequencies more than X megahertz from the channel edge, where X is the greater of 6 megahertz or the actual emission bandwidth as defined in paragraph (m)(6) of this section. In addition, the attenuation factor shall not be less than $43 + 10 \log(P)$ dB on all frequencies between 2490.5 MHz and 2496 MHz and $55 + 10 \log(P)$ dB at or below 2490.5 MHz. Mobile Satellite Service licensees operating on frequencies below 2495 MHz may also submit a documented interference complaint against BRS licensees operating on channel BRS Channel 1 on the same terms and conditions as adjacent channel BRS or EBS licensees.

2.5.2. Test Description

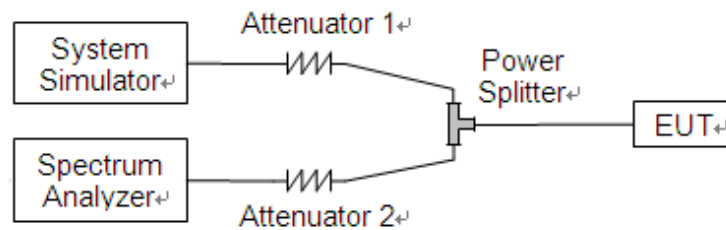

The EUT is coupled to the Spectrum Analyzer (SA) and the System Simulator (SS) with Attenuators through the Power Splitter; the RF load attached to the EUT antenna terminal is 50 Ohm; the path loss as the factor is calibrated to correct the reading. The EUT is commanded by the SS to operate at the maximum output power. A call is established between the EUT and the SS.

2.5.3. Test procedure

KDB 971168 D01v03 Section 6.0 and ANSI/TIA-603-E-2016.



REPORT No.: SZ21020185W12

2.5.4. Test Result

The center frequency of spectrum is the band edge frequency and span is 2MHz, Record the max trace into the test report.



B2_N41(20M)_DFT-s-OFDM_BPSK_Edge_1R
B_Left_Low_CH

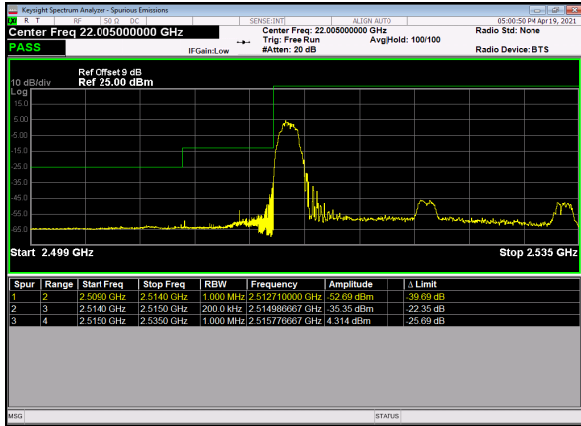

B2_N41(20M)_DFT-s-OFDM_QPSK_Edge_1R
B_Left_Low_CH

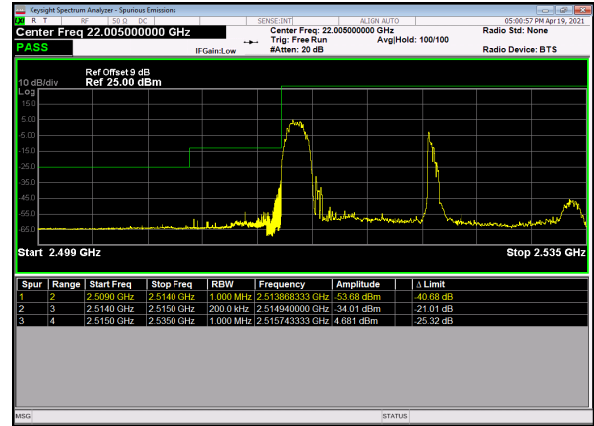

B2_N41(20M)_DFT-s-OFDM_BPSK_Outer
Full_Low_CH

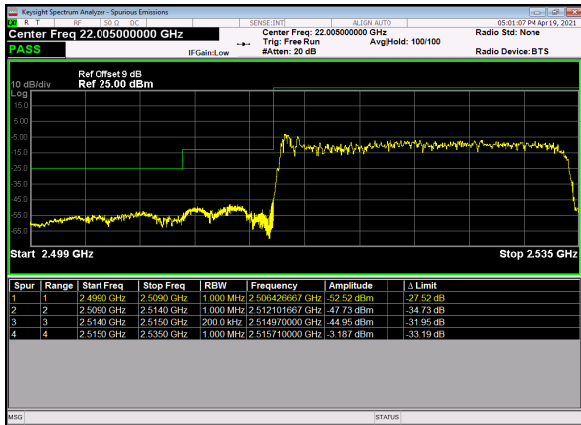

B2_N41(20M)_DFT-s-OFDM_QPSK_Outer
Full_Low_CH

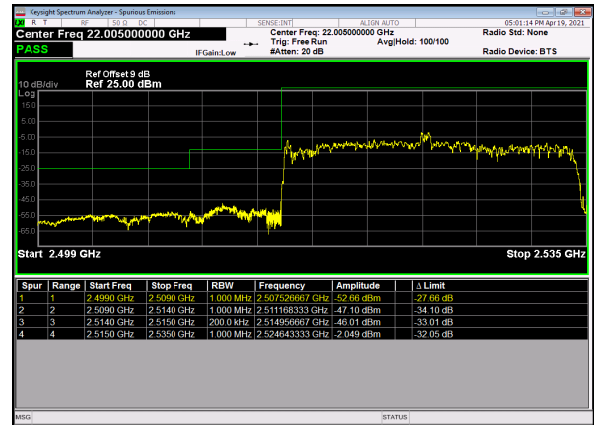

B2_N41(20M)_DFT-s-OFDM_BPSK_Edge_1R
B_Right_High_CH

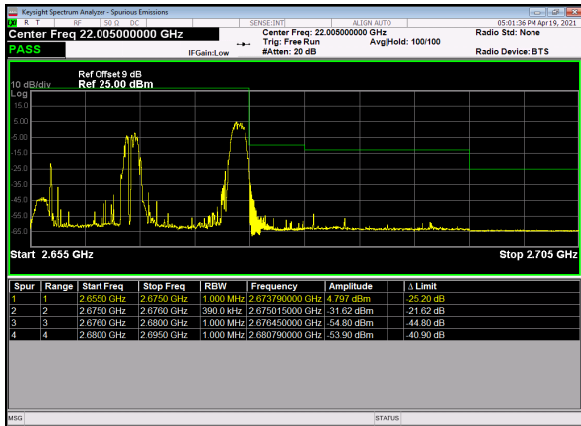

B2_N41(20M)_DFT-s-OFDM_QPSK_Edge_1R
B_Right_High_CH

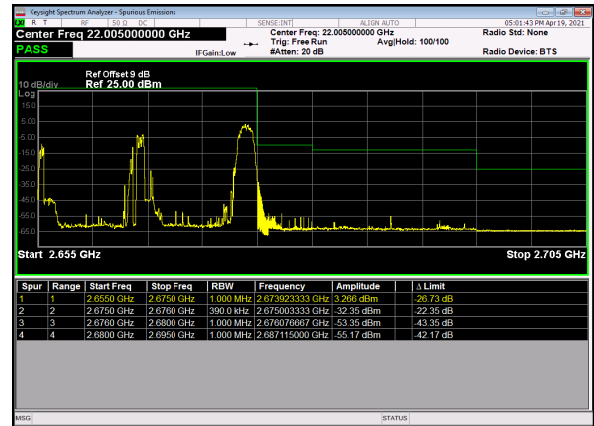



B2_N41(20M)_DFT-s-OFDM_BPSK_Outer_Full_High_CH

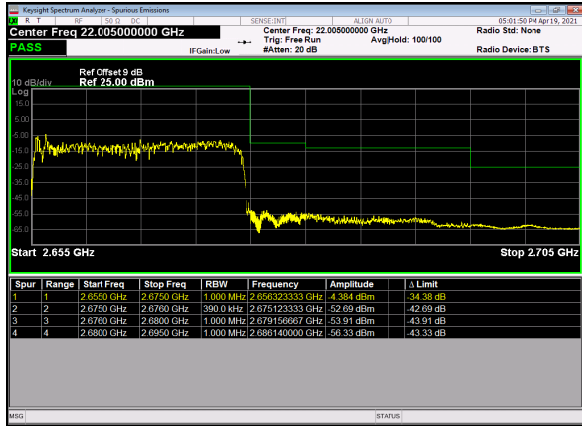

B2_N41(20M)_DFT-s-OFDM_QPSK_Outer_Full_High_CH

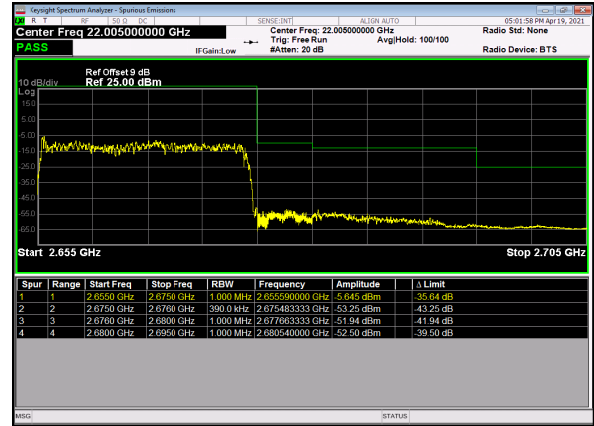

B2_N41(40M)_DFT-s-OFDM_BPSK_Edge_1R_B_Left_Low_CH

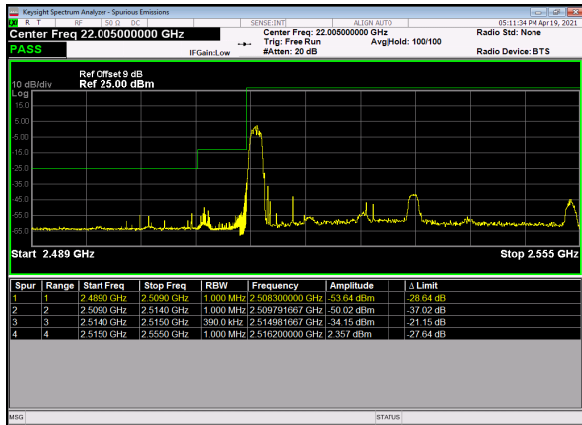

B2_N41(40M)_DFT-s-OFDM_QPSK_Edge_1R_B_Left_Low_CH

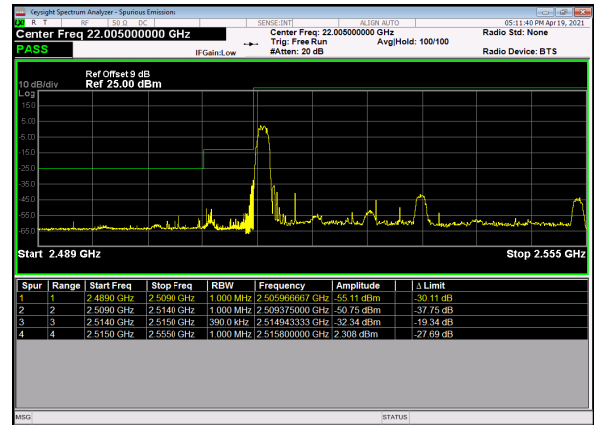

B2_N41(40M)_DFT-s-OFDM_BPSK_Outer_Full_Low_CH

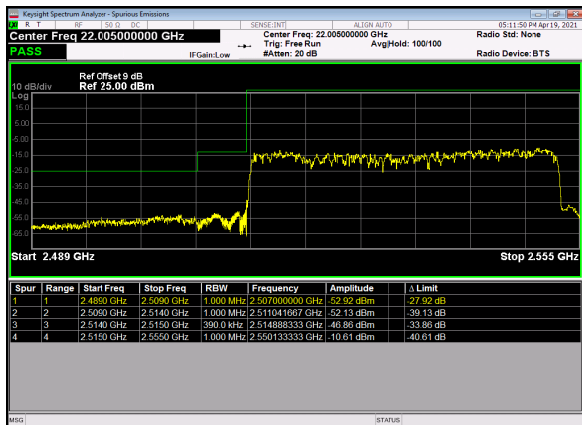

B2_N41(40M)_DFT-s-OFDM_QPSK_Outer_Full_Low_CH

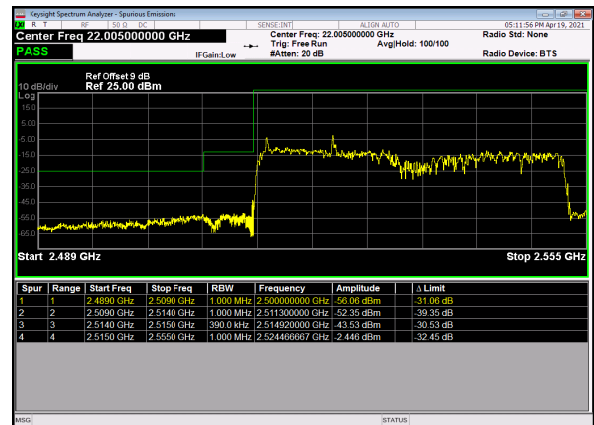



B2_N41(40M)_DFT-s-OFDM_BPSK_Edge_1R
B_Right_High_CH

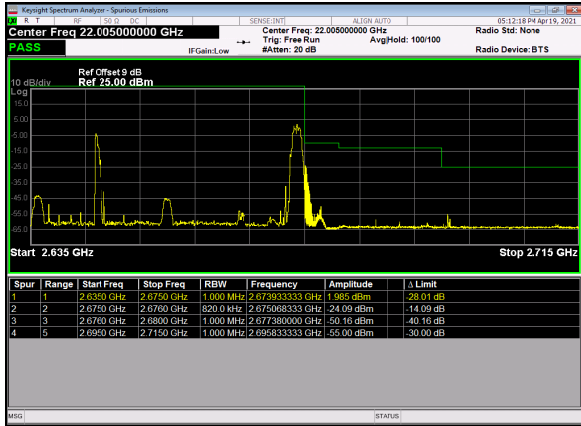

B2_N41(40M)_DFT-s-OFDM_QPSK_Edge_1R
B_Right_High_CH

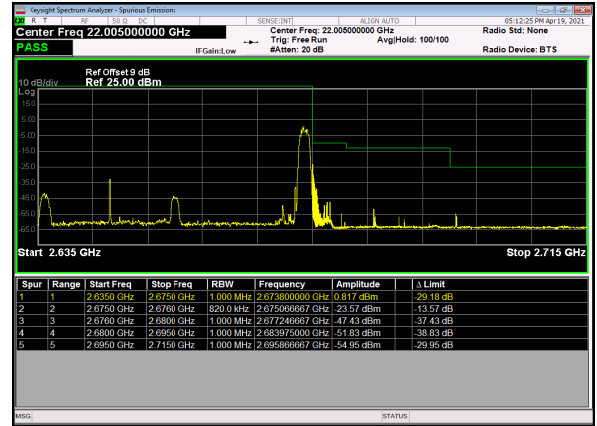

B2_N41(40M)_DFT-s-OFDM_BPSK_Outer
Full_High_CH

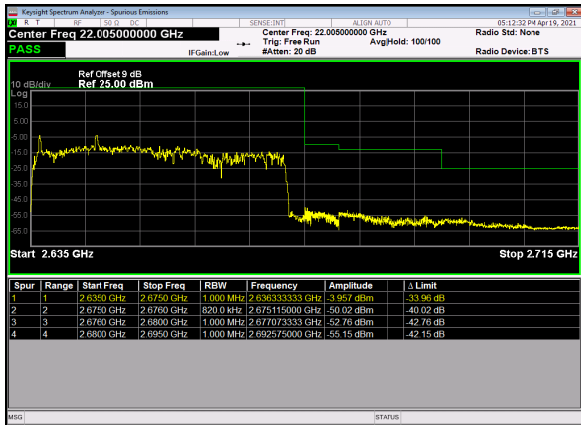

B2_N41(40M)_DFT-s-OFDM_QPSK_Outer
Full_High_CH

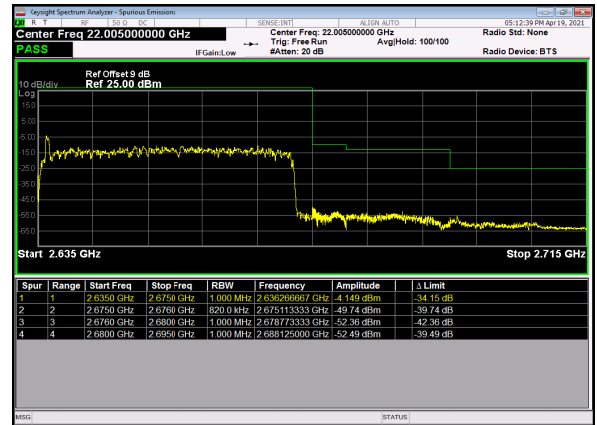

B2_N41(50M)_DFT-s-OFDM_BPSK_Edge_1RB_Left_Low_CH

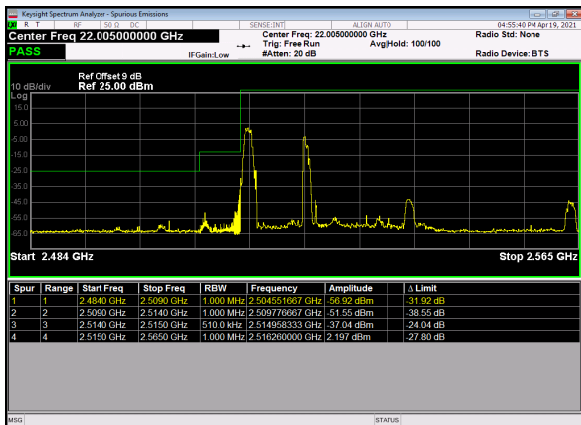

B2_N41(50M)_DFT-s-OFDM_QPSK_Edge_1RB_Left_Low_CH

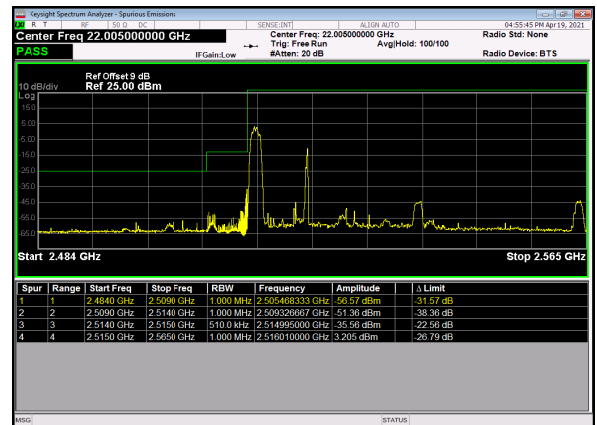



B2_N41(50M)_DFT-s-OFDM_BPSK_Outer_Full_Low_CH

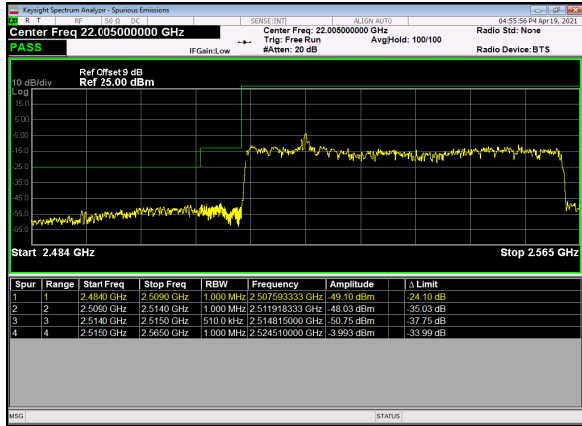

B2_N41(50M)_DFT-s-OFDM_QPSK_Outer_Full_Low_CH

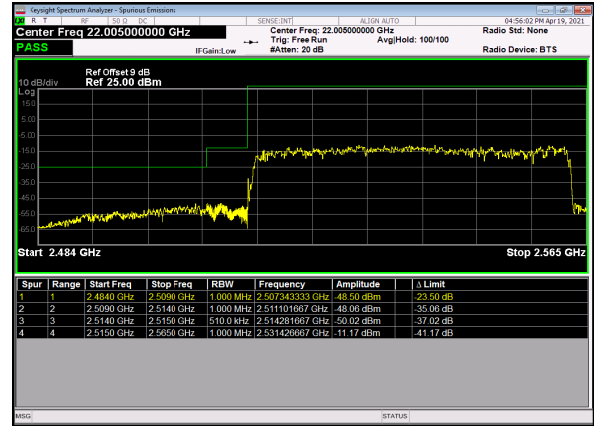

B2_N41(50M)_DFT-s-OFDM_BPSK_Edge_1R_B_Right_High_CH

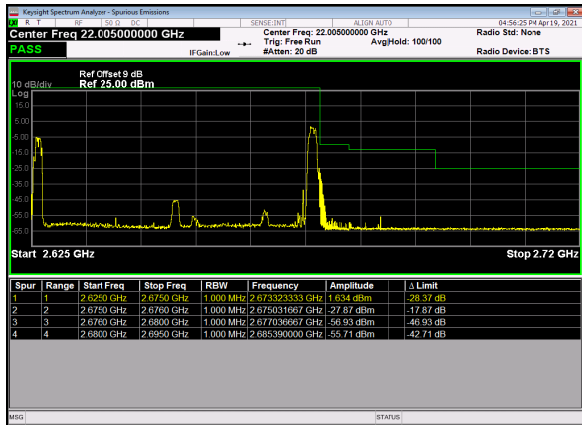

B2_N41(50M)_DFT-s-OFDM_QPSK_Edge_1R_B_Right_High_CH

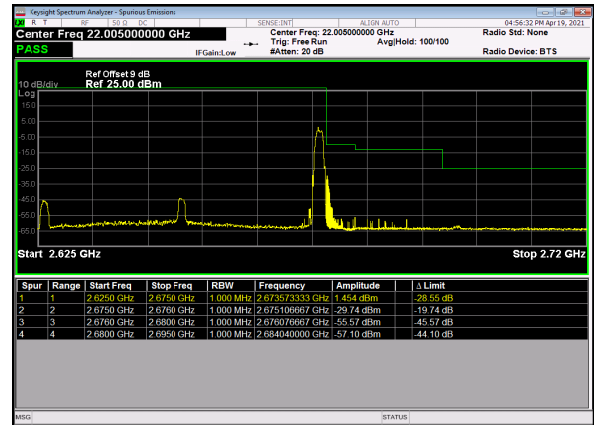

B2_N41(50M)_DFT-s-OFDM_BPSK_Outer_Full_High_CH

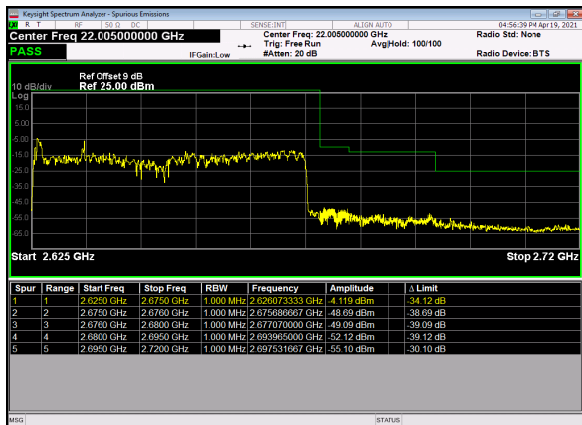

B2_N41(50M)_DFT-s-OFDM_QPSK_Outer_Full_High_CH

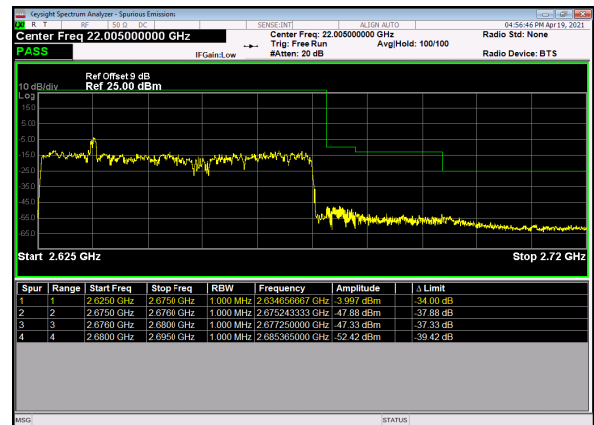



B2_N41(60M)_DFT-s-OFDM_BPSK_Edge_1RB_Left_Low_CH

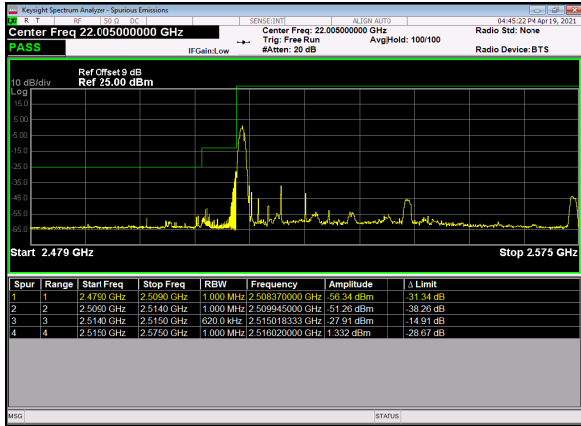

B2_N41(60M)_DFT-s-OFDM_QPSK_Edge_1RB_Left_Low_CH

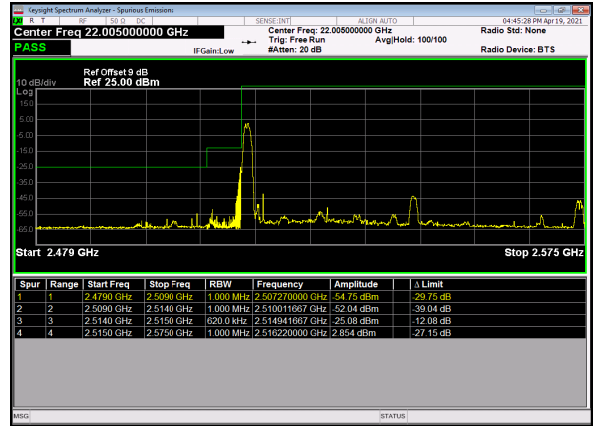

B2_N41(60M)_DFT-s-OFDM_BPSK_Outer_Full_Low_CH

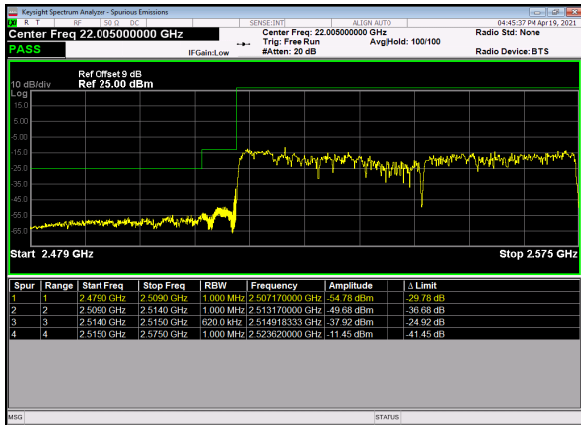

B2_N41(60M)_DFT-s-OFDM_QPSK_Outer_Full_Low_CH

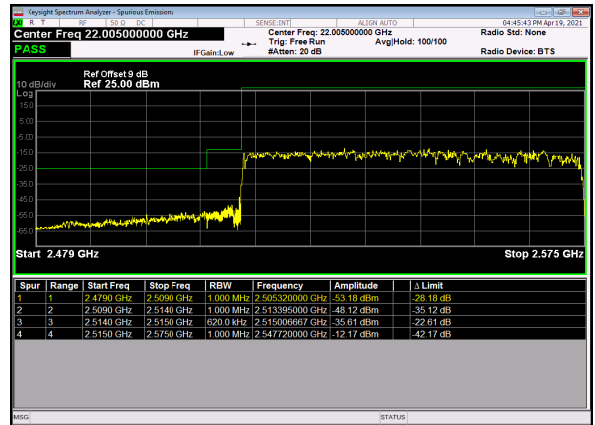

B2_N41(60M)_DFT-s-OFDM_BPSK_Edge_1RB_Right_High_CH

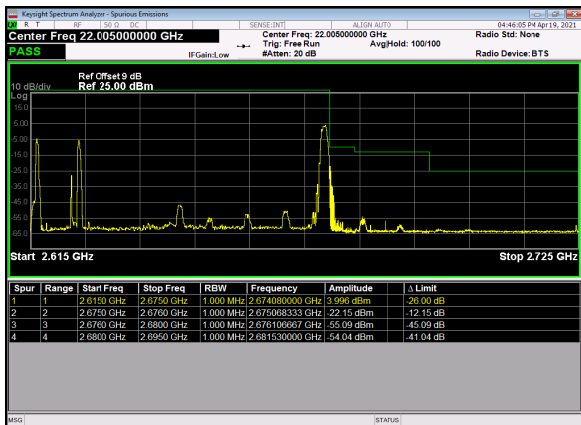

B2_N41(60M)_DFT-s-OFDM_QPSK_Edge_1RB_Right_High_CH

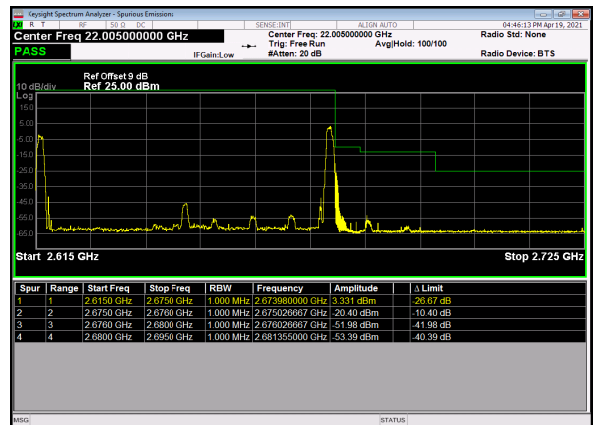



B2_N41(60M)_DFT-s-OFDM_BPSK_Outer_Full_High_CH

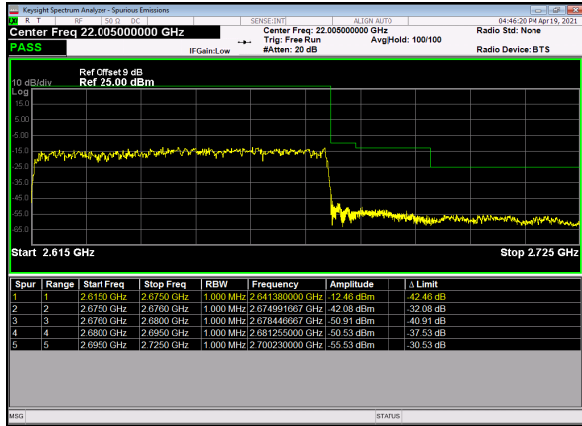

B2_N41(60M)_DFT-s-OFDM_QPSK_Outer_Full_High_CH

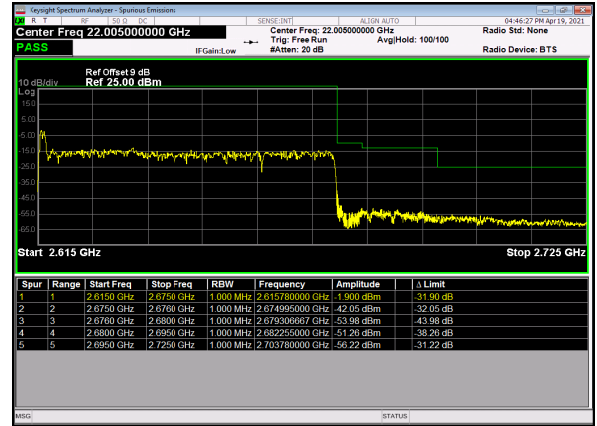

B2_N41(80M)_DFT-s-OFDM_BPSK_Edge_1R_B_Left_Low_CH

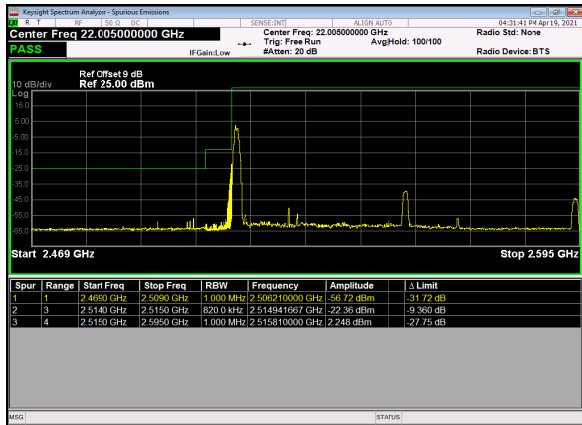

B2_N41(80M)_DFT-s-OFDM_QPSK_Edge_1R_B_Left_Low_CH

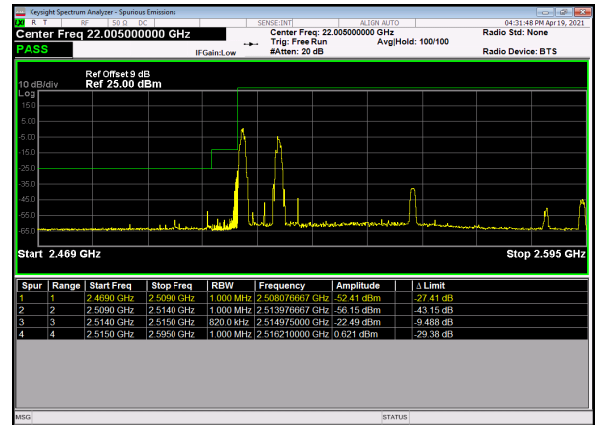

B2_N41(80M)_DFT-s-OFDM_BPSK_Outer_Full_Low_CH

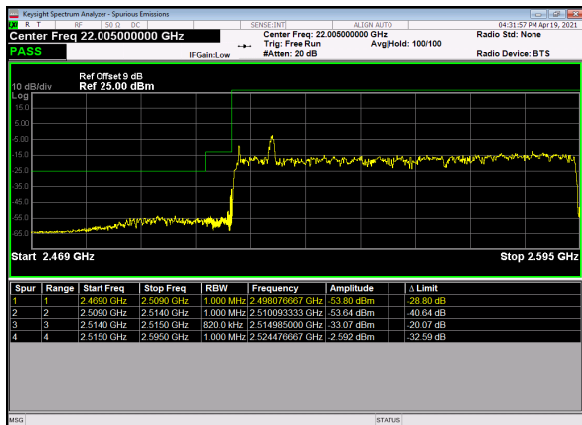

B2_N41(80M)_DFT-s-OFDM_QPSK_Outer_Full_Low_CH

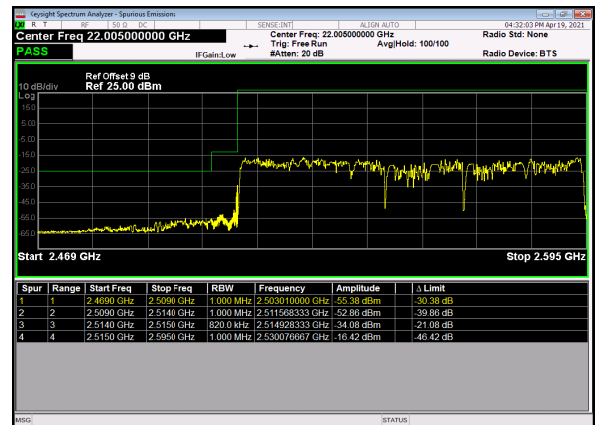



B2_N41(80M)_DFT-s-OFDM_BPSK_Edge_1R
B_Right_High_CH

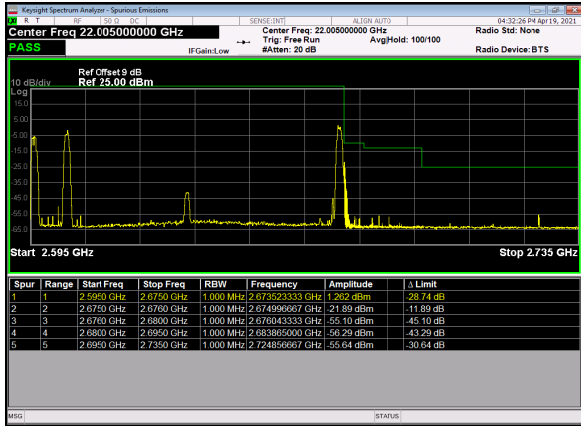

B2_N41(80M)_DFT-s-OFDM_QPSK_Edge_1R
B_Right_High_CH

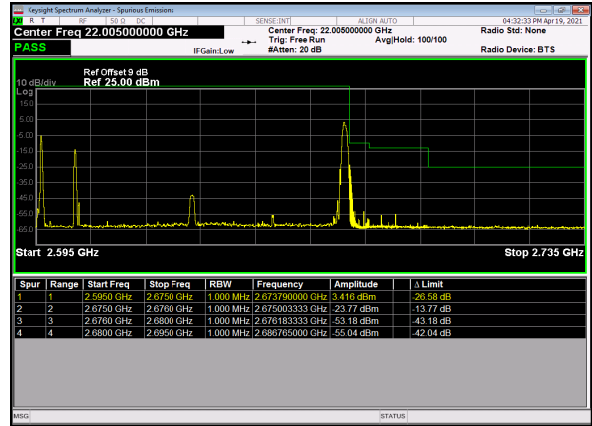

B2_N41(80M)_DFT-s-OFDM_BPSK_Outer
Full_High_CH

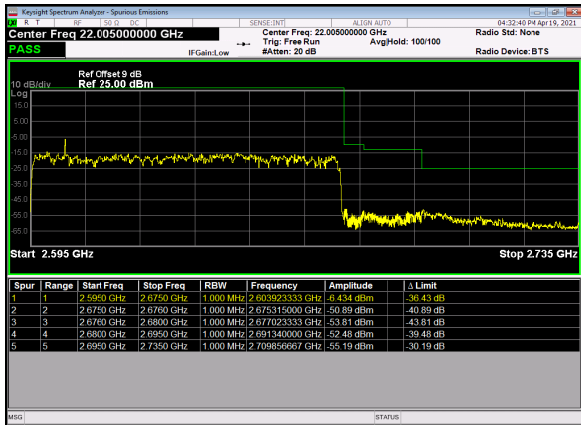

B2_N41(80M)_DFT-s-OFDM_QPSK_Outer
Full_High_CH

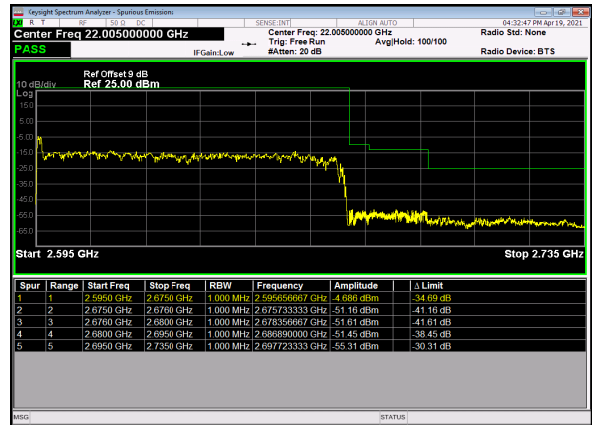

B2_N41(90M)_DFT-s-OFDM_BPSK_Edge_1RB_Left_Low_CH

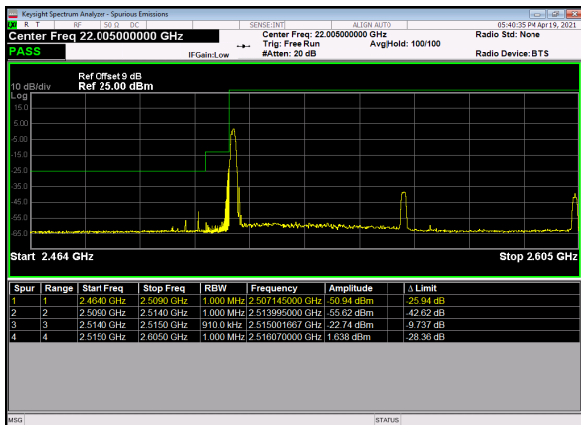

B2_N41(90M)_DFT-s-OFDM_QPSK_Edge_1RB_Left_Low_CH

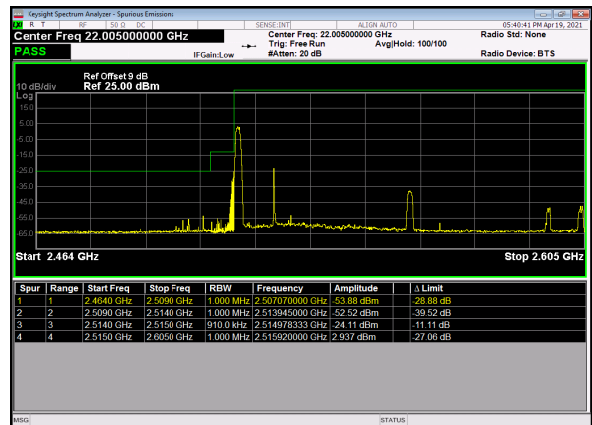



B2_N41(90M)_DFT-s-OFDM_BPSK_Outer_Full_Low_CH

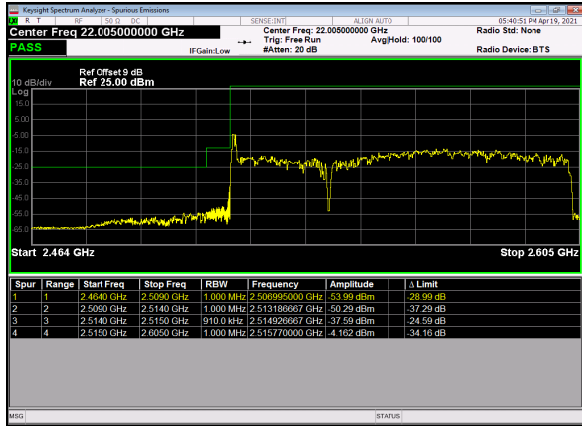

B2_N41(90M)_DFT-s-OFDM_QPSK_Outer_Full_Low_CH

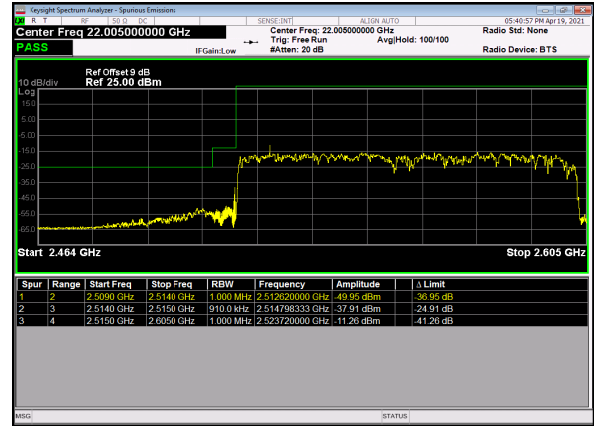

B2_N41(90M)_DFT-s-OFDM_BPSK_Edge_1RB_Right_High_CH

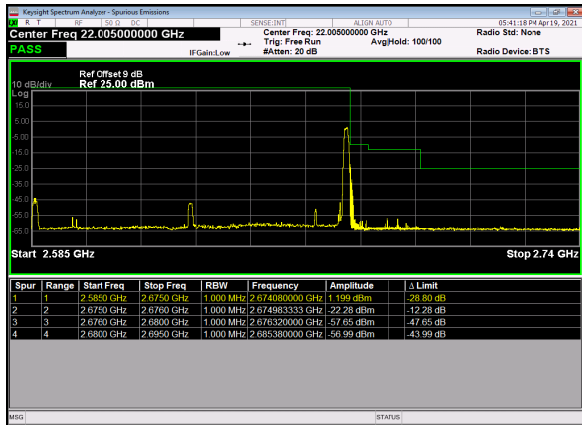

B2_N41(90M)_DFT-s-OFDM_QPSK_Edge_1RB_Right_High_CH

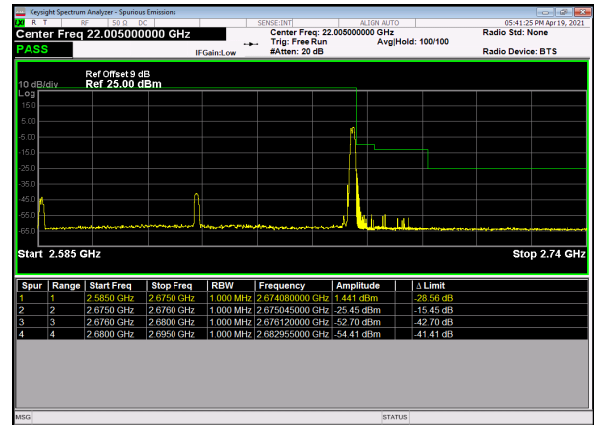

B2_N41(90M)_DFT-s-OFDM_BPSK_Outer_Full_High_CH

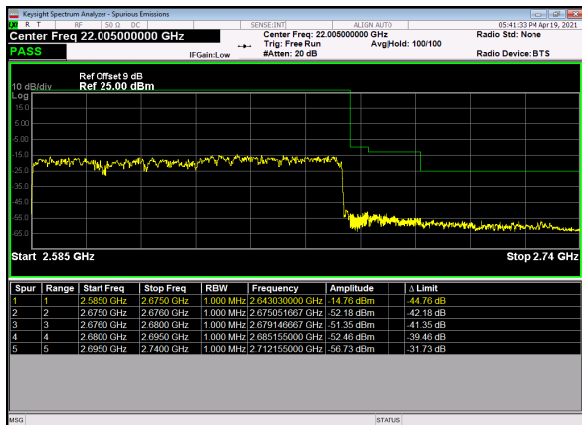

B2_N41(90M)_DFT-s-OFDM_QPSK_Outer_Full_High_CH

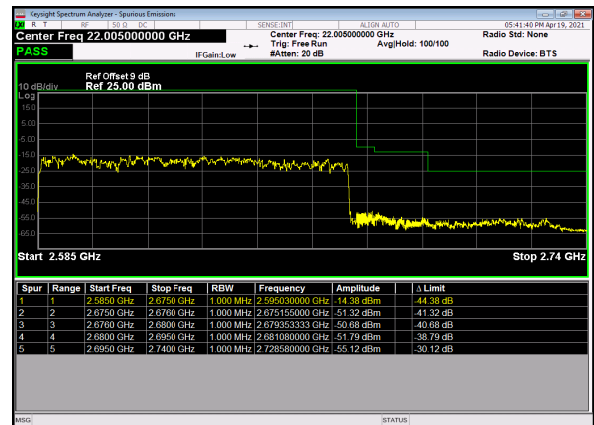



B2_N41(100M)_DFT-s-OFDM_BPSK_Edge_1RB_Left_Low_CH

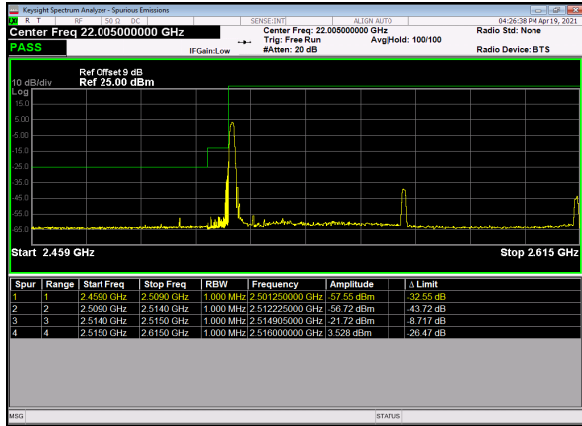

B2_N41(100M)_DFT-s-OFDM_QPSK_Edge_1RB_Left_Low_CH

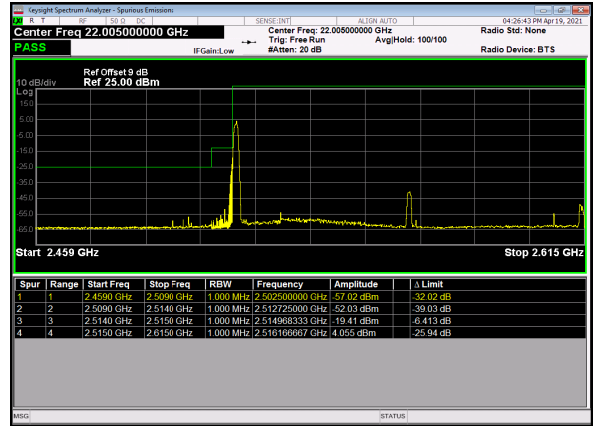

B2_N41(100M)_DFT-s-OFDM_BPSK_Outer_Full_Low_CH

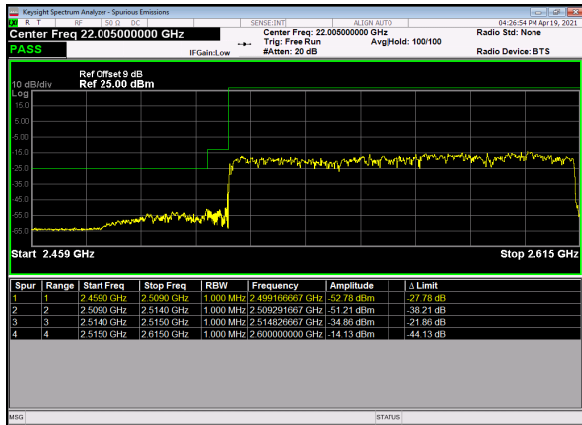

B2_N41(100M)_DFT-s-OFDM_QPSK_Outer_Full_Low_CH

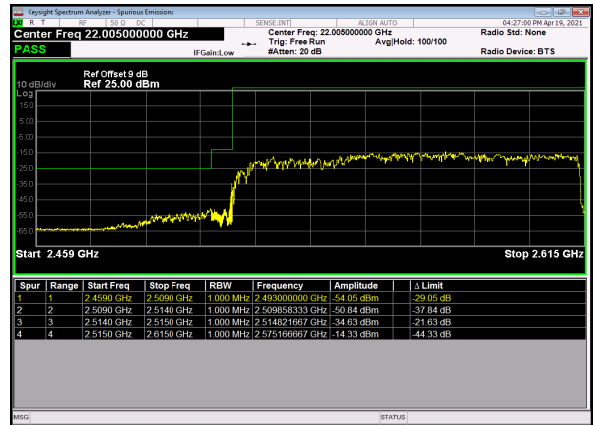

B2_N41(100M)_DFT-s-OFDM_BPSK_Edge_1RB_Right_High_CH

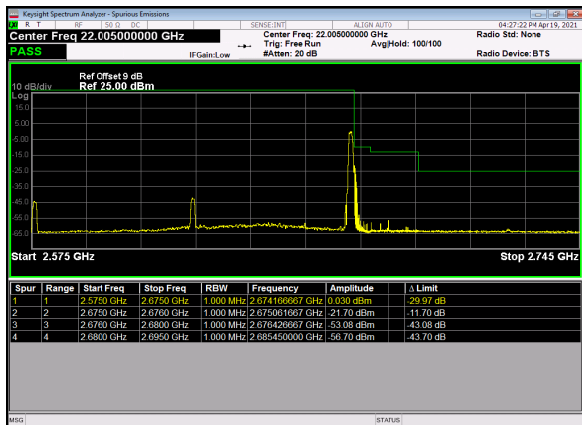

B2_N41(100M)_DFT-s-OFDM_QPSK_Edge_1RB_Right_High_CH

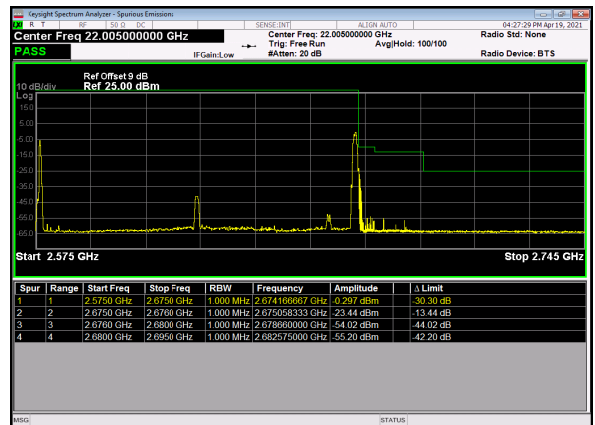



B2_N41(100M)_DFT-s-OFDM_BPSK_Outer_Full_High_CH

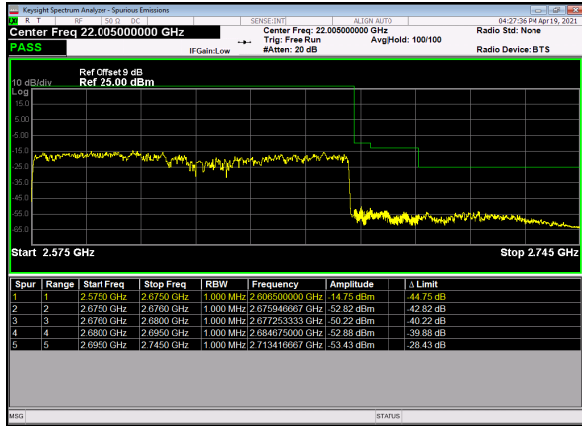

B2_N41(100M)_DFT-s-OFDM_QPSK_Outer_Full_High_CH

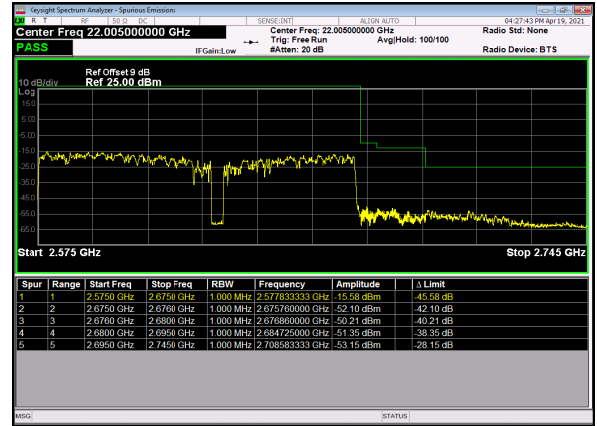

2.6. Radiated Spurious Emissions

2.6.1. Requirement

According to FCC section 2.1051, the power of any emission outside of the authorized operating frequency ranges must be attenuated below the transmitting power (P) by a factor of at least $43 + 10 \cdot \log(P)$ dB. This calculated to be -13dBm.

Additional requirement for NR Band n41:

The power of any emission outside of the authorized operating frequency ranges must be attenuated below the transmitting power (P) by a factor of at least $55 + 10 \log(P)$ dB. This calculated to be -25dBm.

2.6.2. Test Description

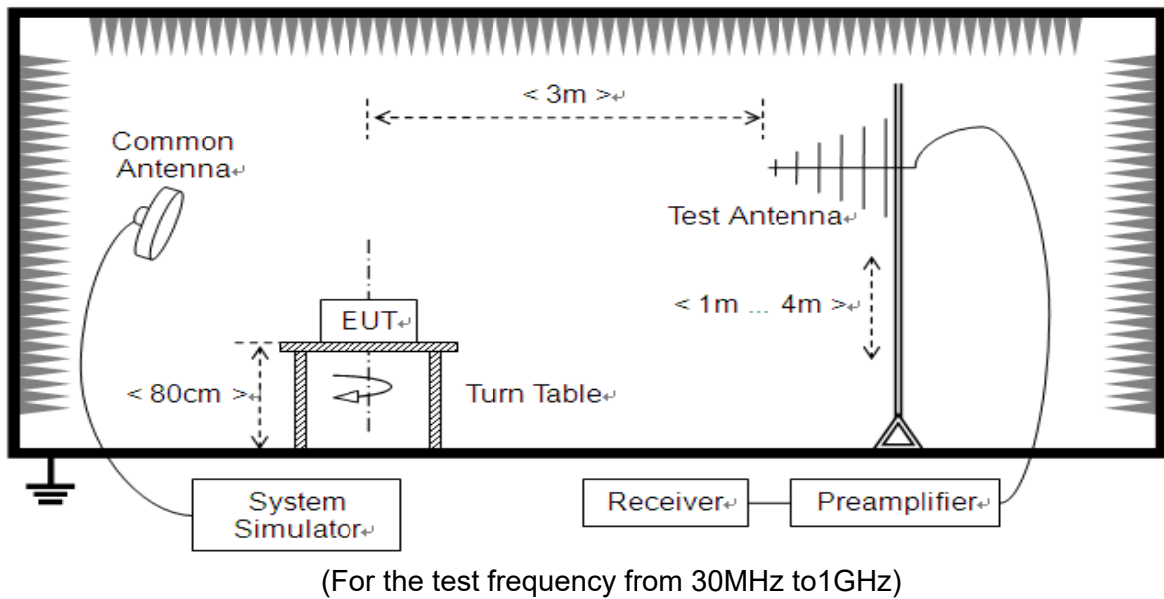

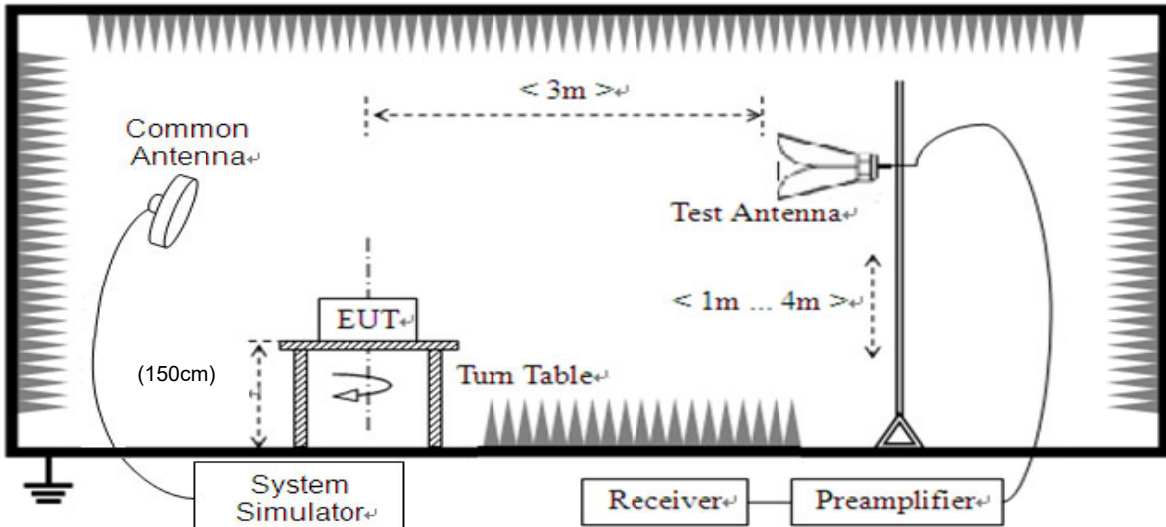

(For the test frequency above 1GHz)

The EUT is located in a 3m Full-Anechoic Chamber, the cable loss, air loss and so on of the site as factors are pre-calibrated using the "Substitution" method, and calculated to correct the reading. A call is established between the EUT and the SS via a Common Antenna. The EUT is commanded by the SS to operate at the maximum and minimum output power, and only the test result of the maximum output power was recorded.

In the frequency range above 30MHz, Bi-Log Test Antenna (30MHz to 1GHz) and Horn Test Antenna (above 1GHz) are used. Test Antenna is 3m away from the EUT. Test Antenna height is varied from 1m to 4m above the ground and the Turn Table is actuated to turn from 0° to 360° to determine the maximum value of the radiated power. The emission levels at both horizontal and vertical polarizations should be tested. The Filters consists of Notch Filters and High Pass Filter.

Note: when doing measurements above 1GHz, the EUT has been within the 3dB cone width of the horn antenna during horizontal antenna.

2.6.3. Test procedure

KDB 971168 D01v03 Section 5.8 and ANSI/TIA-603-E-2016.



2.6.4. Test Result

The measurement frequency range is from 30MHz to the 10th harmonic of the fundamental frequency. Test Antenna height is varied from 1m to 4m above the ground, and the Turn Table is actuated to turn from 0° to 360°, both horizontal and vertical polarizations of the Test Antenna are used to find the maximum radiated power. Mid channels on all channel bandwidth verified. Only the worst RB size/offset presented.

The substitution corrections are obtained as described below:

$$A_{\text{SUBST}} = P_{\text{SUBST_TX}} - P_{\text{SUBST_RX}} - L_{\text{SUBST_CABLES}} + G_{\text{SUBST_TX_ANT}}$$

$$A_{\text{TOT}} = L_{\text{CABLES}} + A_{\text{SUBST}}$$

Where A_{SUBST} is the final substitution correction including receive antenna gain.

$P_{\text{SUBST_TX}}$ is signal generator level,

$P_{\text{SUBST_RX}}$ is receiver level,

$L_{\text{SUBST_CABLES}}$ is cable losses including TX cable,

$G_{\text{SUBST_TX_ANT}}$ is substitution antenna gain.

A_{TOT} is total correction factor including cable loss and substitution correction

During the test, the data of A_{TOT} was added in the Test Spectrum Analyze, so Spectrum Analyze reading is the final values which contain the data of A_{TOT} .

Note1: The power of the EUT transmitting frequency should be ignored.

Note2: All Spurious Emission tests were performed in X, Y, Z axis direction. And only the worst axis test condition was recorded in this test report.

Note3: All bandwidth and modulation were considered and evaluated respectively by performing full test for each band, only the worst cases (Max Bandwidth and QPSK mode) were recorded in this test report.

Top Antenna

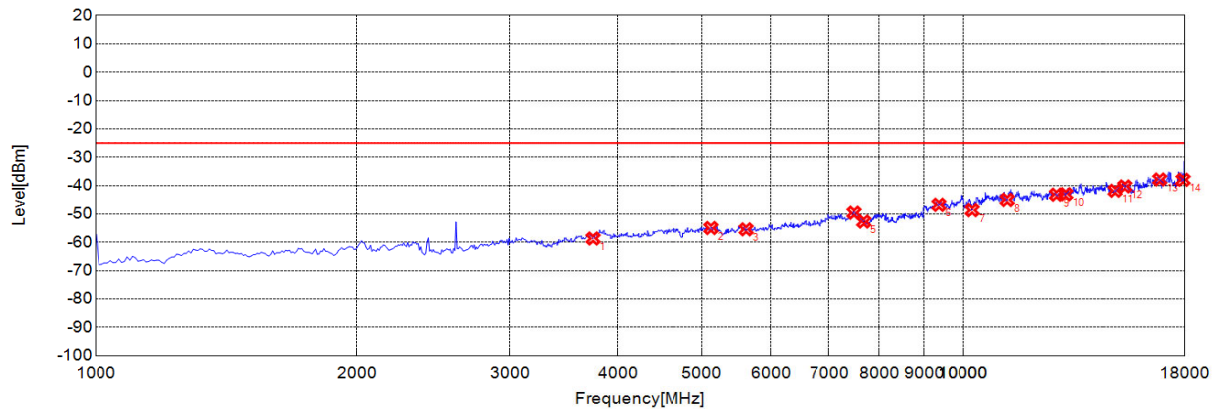

○ Final Test

Suspected List										
NO.	Freq. [MHz]	Level [dBm]	Limit [dBm]	Margin [dB]	Factor [dB]	Path [dB]	Air [dB]	Angle [°]	EUT Pol.	Ant. Pol.
1	3746.7470	-58.66	-25.00	33.66	-8.29	-47.58	39.29	206	Z	Horizontal
2	5124.1240	-54.95	-25.00	29.95	-2.38	-43.83	41.45	287	Z	Horizontal
3	5620.6210	-55.43	-25.00	30.43	-2.20	-43.01	40.81	232	Z	Horizontal
4	7486.4860	-49.54	-25.00	24.54	7.83	-38.28	46.11	64	Z	Horizontal
5	7678.6790	-52.67	-25.00	27.67	6.88	-38.14	45.02	253	Z	Horizontal
6	9360.3600	-46.79	-25.00	21.79	12.07	-36.84	48.91	119	Z	Horizontal
7	10243.2430	-48.66	-25.00	23.66	11.25	-37.30	48.55	190	Z	Horizontal
8	11234.2340	-45.07	-25.00	20.07	13.93	-34.74	48.67	117	Z	Horizontal
9	12792.7930	-43.24	-25.00	18.24	19.36	-30.12	49.48	131	Z	Horizontal
10	13108.1080	-43.1	-25.00	18.10	19.90	-29.97	49.87	252	Z	Horizontal
11	14972.9730	-41.86	-25.00	16.86	20.22	-29.60	49.82	312	Z	Horizontal
12	15360.3600	-40.33	-25.00	15.33	22.05	-28.73	50.78	186	Z	Horizontal
13	16846.8470	-37.87	-25.00	12.87	25.19	-26.76	51.95	203	Z	Horizontal
14	17918.9190	-37.98	-25.00	12.98	29.85	-25.61	55.46	238	Z	Horizontal

DC 2C N41 512004 90M DFT-s-OFDM QPSK Size-1RB Offset-243RB SCS 30 kHz 1-18G H