

FCC

RF

TEST REPORT

ISSUED BY  
Shenzhen BALUN Technology Co., Ltd.



FOR  
**LTE Digital Mobile Phone**

ISSUED TO  
Nubia Technology Co., Ltd.

6/F, Tower A, Hans Innovation Mansion, North Ring Rd., No. 9018,  
Hi-Tech Industrial Park, Nanshan District, Shenzhen, P. R. China



Tested by:

*Cao Shao Dong*  
Cao Shao Dong  
(Engineer)

Date *Sep. 29, 2016*

Approved by:

*Liao Jianming*  
Liao Jianming  
(Technical Director)

Date *Sep. 29, 2016*

Report No.: BL-SZ1680175-605

EUT Type: LTE Digital Mobile Phone

Model NX531J, nubia Z11

Brand Name: nubia

Test Standard: 47 CFR Part 15 Subpart E

FCC ID: 2AHJO-NX531J

Test conclusion: Pass

Test Date: Sep. 02, 2016 ~ Sep. 09, 2016

Date of Issue: Sep. 29, 2016

*NOTE: This test report can be duplicated completely for the legal use with the approval of the applicant; it shall not be reproduced except in full, without the written approval of Shenzhen BALUN Technology Co., Ltd. BALUN Laboratory. Any objections should be raised within thirty days from the date of issue. To validate the report, please visit BALUN website.*

**Revision History**

| <u>Version</u> | <u>Issue Date</u> | <u>Revisions</u>                                      |
|----------------|-------------------|---|
| Rev. 01        | Sep. 22, 2016     | Initial Issue   |
| Rev. 01        | Sep. 29, 2016     | Add the plots of the radar waveforms at page 14, etc. |

**TABLE OF CONTENTS**

1 ADMINISTRATIVE DATA (GENERAL INFORMATION) .....4

    1.1 Identification of the Testing Laboratory .....4

    1.2 Identification of the Responsible Testing Location .....4

    1.3 Laboratory Condition .....4

    1.4 Announce .....4

2 PRODUCT INFORMATION .....5

    2.1 Applicant Information .....5

    2.2 Manufacturer Information .....5

    2.3 Factory Information .....5

    2.4 General Description for Equipment under Test (EUT) .....5

    2.5 Ancillary Equipment .....5

    2.6 Technical Information .....6

3 SUMMARY OF TEST RESULTS .....7

    3.1 Test Standards .....7

    3.2 Verdict .....7

    3.3 Test Uncertainty .....7

4 GENERAL TEST CONFIGURATIONS .....8

    4.1 Test Environments .....8

    4.2 Test Equipment List .....8

    4.3 Description of Test Setup .....9

        4.3.1 Conducted Test Setup Configuration .....9

5 Test Type and Test Results .....10

    5.1 DFS .....10

        5.1.1 U-NII DFS Rule Requirements .....10

        5.1.2 Test Limits and Radar Signal Parameters .....10

ANNEX A TEST RESULT ..... 18

    A.1 CHANNEL CLOSING TRANSMISSION AND CHANNEL MOVE TIME..... 18

    A.2 NON- OCCUPANCY PERIOD .....21

ANNEX B TEST SETUP PHOTOS .....22

ANNEX C EUT EXTERNAL PHOTOS .....22

ANNEX D EUT INTERNAL PHOTOS .....22

# 1 ADMINISTRATIVE DATA (GENERAL INFORMATION)

## 1.1 Identification of the Testing Laboratory

|              |   |
|--------------|---|
| Company Name | Shenzhen BALUN Technology Co., Ltd.   |
| Address      | Block B, 1st FL, Baisha Science and Technology Park, Shahe Xi Road, Nanshan District, Shenzhen, Guangdong Province, P. R. China |
| Phone Number | +86 755 6685 0100   |
| Fax Number   | +86 755 6182 4271   |

## 1.2 Identification of the Responsible Testing Location

|                           |   |
|---------------------------|---|
| Test Location             | Shenzhen BALUN Technology Co., Ltd.   |
| Address                   | Block B, 1st FL, Baisha Science and Technology Park, Shahe Xi Road, Nanshan District, Shenzhen, Guangdong Province, P. R. China   |
| Accreditation Certificate | <p>The laboratory has been listed by Industry Canada to perform electromagnetic emission measurements. The recognition numbers of test site are 11524A-1.</p> <p>The laboratory has been listed by US Federal Communications Commission to perform electromagnetic emission measurements. The recognition numbers of test site are 832625.</p> <p>The laboratory is a testing organization accredited by China National Accreditation Service for Conformity Assessment (CNAS) according to ISO/IEC 17025. The accreditation certificate number is L6791.</p> |
| Description               | All measurement facilities used to collect the measurement data are located at Block B, FL 1, Baisha Science and Technology Park, Shahe Xi Road, Nanshan District, Shenzhen, Guangdong Province, P. R. China 518055   |

## 1.3 Laboratory Condition

|                           |                   |
|---------------------------|-------------------|
| Ambient Temperature       | 20 to 25°C        |
| Ambient Relative Humidity | 45% - 55%         |
| Ambient Pressure          | 100 kPa - 102 kPa |

## 1.4 Announce

- (1) The test report reference to the report template version v2.2.
- (2) The test report is invalid if not marked with the signatures of the persons responsible for preparing and approving the test report.
- (3) The test report is invalid if there is any evidence and/or falsification.
- (4) The results documented in this report apply only to the tested sample, under the conditions and modes of operation as described herein.
- (5) This document may not be altered or revised in any way unless done so by BALUN and all revisions are duly noted in the revisions section.
- (6) Content of the test report, in part or in full, cannot be used for publicity and/or promotional purposes without prior written approval from the laboratory.

## 2 PRODUCT INFORMATION

### 2.1 Applicant Information

|           |   |
|-----------|---|
| Applicant | Nubia Technology Co., Ltd.  |
| Address   | 6/F, Tower A, Hans Innovation Mansion, North Ring Rd., No. 9018, Hi-Tech Industrial Park, Nanshan District, Shenzhen, P. R. China |

### 2.2 Manufacturer Information

|              |   |
|--------------|---|
| Manufacturer | Nubia Technology Co., Ltd.  |
| Address      | 6/F, Tower A, Hans Innovation Mansion, North Ring Rd., No. 9018, Hi-Tech Industrial Park, Nanshan District, Shenzhen, P. R. China |

### 2.3 Factory Information

|         |     |
|---------|-----|
| Factory | N/A |
| Address | N/A |

### 2.4 General Description for Equipment under Test (EUT)

|   |  |
|---|--|
| EUT Type                                  | LTE Digital Mobile Phone   |
| Model Name Under Test                     | NX531J   |
| Series Model Name                         | NX531J, nubia Z11  |
| Description of Model name differentiation | The equipment model NX531J and nubia Z11 are LTE Digital Mobile Phone, the electrical parameters and internal structure of circuit are same, only the model name is different.   |
| Hardware Version                          | NX531J_V2AMB_B   |
| Software Version                          | NX531J_ENCommon_V1.09  |
| Dimensions (Approx.)                      | N/A  |
| Weight (Approx.)                          | N/A  |
| Network and Wireless connectivity         | 2G Network GSM/GPRS/EDGE 850/1900 MHz<br>3G Network WCDMA/HSDPA/HSUPA/HSPA + Band 2/4/5<br>4G Network FDD LTE Band 2/4/5/7/12/17<br>Bluetooth 3.0, Bluetooth 4.0 Low Energy (BLE),<br>WIFI 802.11a,802.11b, 802.11g and 802.11n (HT20/40), 802.11ac<br>GPS, GLONASS, NFC |

### 2.5 Ancillary Equipment

|                       |                      |                    |
|-----------------------|----------------------|--------------------|
| Ancillary Equipment 1 | Battery              |                    |
|                       | Brand Name           | N/A                |
|                       | Model No.            | Li3829T44P6h806435 |
|                       | Serial No.           | N/A                |
|                       | Capacitance          | 2900 mAh           |
|                       | Rated Voltage        | 3.85 V             |
| Ancillary Equipment 2 | Limit Charge Voltage | 4.4 V              |
|                       | Charger              |                    |
|                       | Brand Name           | nubia              |

|                       |                      |  |
|-----------------------|----------------------|--|
|                       | Model No.            | STC-A5930A-Z                               |
|                       | Rated Voltage        | 100-240 V~ , 0.5 A, 50/60 Hz               |
|                       | Limit Charge Voltage | 5 V=, 3.0 A or 9 V=, 2.0 A or 12 V=, 1.5 A |
| Ancillary Equipment 3 | Earphone             |  |
|                       | Length (Approx.)     | 1.0 m                                      |
| Ancillary Equipment 4 | USB Data Cable       |  |
|                       | Length (Approx.)     | 1.0 m                                      |

## 2.6 Technical Information

The requirement for the following technical information of the EUT was tested in this report:

|                      |                   |   |
|----------------------|-------------------|---|
| Frequency Range      |                   | 5250 MHz to 5350 MHz, 5350 MHz to 5470 MHz  |
| Maximum Output Power |                   | 5250 MHz to 5350 MHz: 13.20 dBm<br>5350 MHz to 5470 MHz: 13.60 dBm                                  |
| Antenna Type         | Antenna 0 (ANT 0) | PIFA Antenna  |
|                      | Antenna 1 (ANT 1) |   |
| Antenna Gain         | Antenna 0 (ANT 0) | 5250 MHz to 5350 MHz: 0.7 dBi<br>5350 MHz to 5470 MHz: 0.6 dBi                                      |
|                      | Antenna 1 (ANT 1) | 5250 MHz to 5350 MHz: 0.7 dBi<br>5350 MHz to 5470 MHz: 0.6 dBi                                      |
| About the Product    |                   | The equipment is LTE Digital Mobile Phone, intended for used with information technology equipment. |

This device (Client) is without radar detection, then the manufacturer statement confirming that information regarding the parameters of the detected Radar Waveforms is not available to the end user. And the device doesn't have Ad Hoc mode on DFS frequency band.



### 3 SUMMARY OF TEST RESULTS

#### 3.1 Test Standards

| No. | Identity                            | Document Title   |
|-----|-------------------------------------|--|
| 1   | 47 CFR Part 15<br>Subpart E         | Unlicensed National Information Infrastructure Devices   |
| 2   | KDB Publication<br>905462 D02v02    | UNII DFS Compliance Procedures New Rules   |
| 3   | KDB Publication<br>905462 D03v01r02 | UNII Clients Without Radar Detection New Rules   |
| 4   | KDB Publication<br>789033 D02v01r03 | Guidelines for Compliance Testing of Unlicensed National Information Infrastructure (U-NII) Devices Part 15, Subpart E |

#### 3.2 Verdict

| Standard Rule | Description                       | Result | Remark     |
|---------------|-----------------------------------|--------|------------|
| 15.407        | Channel Move Time                 | Pass   | Applicable |
| 15.407        | Channel Closing Transmission Time | Pass   | Applicable |
| 15.407        | Non- Occupancy Period             | Pass   | Applicable |

#### 3.3 Test Uncertainty

The following measurement uncertainty levels have been estimated for tests performed on the EUT as specified in CISPR 16-4-2. This uncertainty represents an expanded uncertainty expressed at approximately the 95% confidence level using a coverage factor of  $k=2$ .

| Measurement                        | Value   |
|------------------------------------|---------|
| Conducted emissions (9 KHz-30 MHz) | 3.23 dB |
| Radiated emissions (30 MHz-1 GHz)  | 3.45 dB |
| Radiated emissions (1 GHz-18 GHz)  | 4.55 dB |

## 4 GENERAL TEST CONFIGURATIONS

### 4.1 Test Environments

During the measurement, the normal environmental conditions were within the listed ranges:

|                            |                         |                |
|----------------------------|-------------------------|----------------|
| Relative Humidity          | 45% - 55%               |                |
| Atmospheric Pressure       | 100 kPa - 102 kPa       |                |
| Temperature                | NT (Normal Temperature) | +22°C to +25°C |
|                            | LT (Low Temperature)    | -20°C          |
|                            | HT (High Temperature)   | +60°C          |
| Working Voltage of the EUT | NV (Normal Voltage)     | 3.85 V         |
|                            | LV (Low Voltage)        | 3.30 V         |
|                            | HV (High Voltage)       | 4.40 V         |

### 4.2 Test Equipment List

| Description                       | Manufacturer         | Model      | Serial No. | Cal. Date  | Cal. Due   |
|-----------------------------------|----------------------|------------|------------|------------|------------|
| Spectrum Analyzer                 | ROHDE&SCHWARZ        | FSV-30     | 103118     | 2016.07.13 | 2017.07.12 |
| Vector Signal Generator           | ROHDE&SCHWARZ        | SMBV100A   | 177746     | 2016.07.13 | 2017.07.12 |
| Signal Generator                  | ROHDE&SCHWARZ        | SMB100A    | 260592     | 2016.07.13 | 2017.07.12 |
| Switch Unit with OSP-B157         | ROHDE&SCHWARZ        | OSP120     | 101270     | 2016.07.13 | 2017.07.12 |
| Spectrum Analyzer                 | AGILENT              | E4440A     | MY45304434 | 2015.10.15 | 2016.10.14 |
| EMI Receiver                      | ROHDE&SCHWARZ        | ESRP       | 101036     | 2016.07.05 | 2017.07.04 |
| LISN                              | SCHWARZBECK          | NSLK 8127  | 8127-687   | 2016.07.05 | 2017.07.04 |
| Bluetooth Tester                  | ROHDE&SCHWARZ        | CBT        | 101005     | 2016.07.13 | 2017.07.12 |
| Power Splitter                    | KMW                  | DCPD-LDC   | 1305003215 | --         | --         |
| Power Sensor                      | ROHDE&SCHWARZ        | NRP-Z21    | 103971     | 2016.07.13 | 2017.07.12 |
| Attenuator (20 dB)                | KMW                  | ZA-S1-201  | 110617091  | --         | --         |
| Attenuator (6 dB)                 | KMW                  | ZA-S1-61   | 1305003189 | --         | --         |
| DC Power Supply                   | ROHDE&SCHWARZ        | HMP2020    | 018141664  | 2016.07.13 | 2017.07.12 |
| Temperature Chamber               | ANGELANTIONI SCIENCE | NTH64-40A  | 1310       | 2016.07.13 | 2017.07.12 |
| Test Antenna-Loop(9 kHz-30 MHz)   | SCHWARZBECK          | FMZB 1519  | 1519-037   | 2015.07.22 | 2017.07.21 |
| Test Antenna-Bi-Log(30 MHz-3 GHz) | SCHWARZBECK          | VULB 9163  | 9163-624   | 2015.07.22 | 2017.07.21 |
| Test Antenna-Horn(1-18 GHz)       | SCHWARZBECK          | BBHA 9120D | 9120D-1148 | 2015.07.22 | 2017.07.21 |
| Test Antenna-Horn(15-26.5 GHz)    | SCHWARZBECK          | BBHA 9170  | 9170-305   | 2015.07.22 | 2017.07.21 |
| Anechoic Chamber                  | RAINFORD             | 9m*6m*6m   | N/A        | 2015.02.28 | 2017.02.27 |
| Shielded Enclosure                | ChangNing            | CN-130701  | 130703     | --         | --         |



|        |              |  |
|--------|--------------|--|
| Master | Access Point |  |
|        | Brand Name   | Aerohive   |
|        | Model No.    | AP230  |
|        | Serial No.   | AH-AP-230-AC-W                                       |
|        | FCC ID       | WBV-AP230  |
|        | SPEC.        | The maximum EIRP is 18.5dBm, Antenna Gain is 6.57dBi |

### 4.3 Description of Test Setup

#### 4.3.1 Conducted Test Setup Configuration

Client without Radar Detection Mode

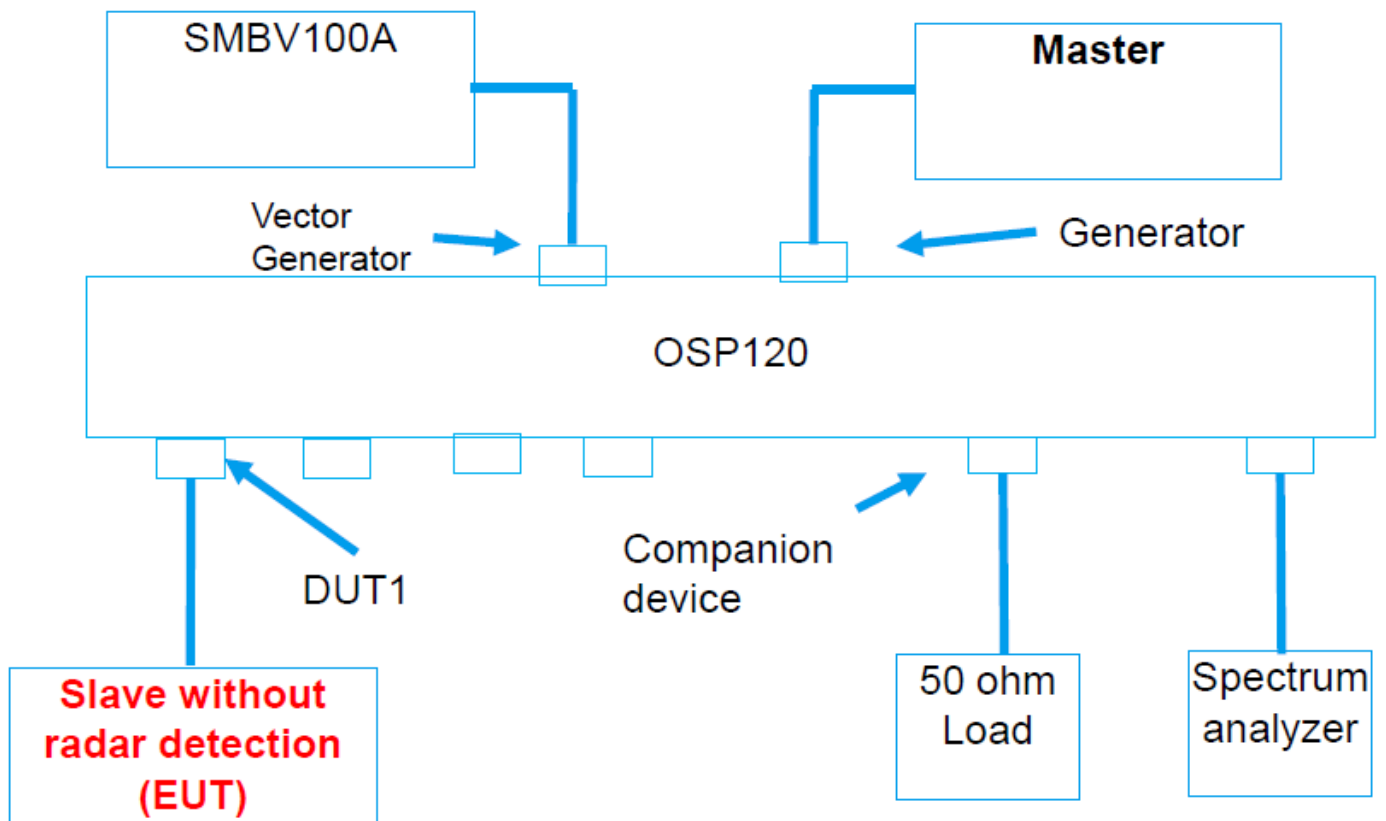

The UUT is a U-NII Device operating in Client mode without radar detection. The radar test signals are injected into the Master Device.

(Diagram 1)

## 5 Test Type and Test Results

### 5.1 DFS

#### 5.1.1 U-NII DFS Rule Requirements

##### 5.1.1.1 Working Mode and Required Test Items

The manufacturer shall state whether the UUT is capable of operating as a Master and/or a Client. If the UUT is capable of operating in more than one operating mode then each operating mode shall be tested separately. See tables 1 and 2 for the applicability of DFS requirements for each of the operational modes.

#### APPLICABILITY OF DFS REQUIREMENTS PRIOR TO USE A CHANNEL

| Requirement                     | Operational Mode |                                |                             |
|---------------------------------|------------------|--------------------------------|-----------------------------|
|                                 | Master           | Client without radar detection | Client with radar detection |
| Non-Occupancy Period            | ✓                | ✓                              | ✓                           |
| DFS Detection Threshold         | ✓                | Not required                   | ✓                           |
| Channel Availability Check Time | ✓                | Not required                   | Not required                |
| Uniform Spreading               | ✓                | Not required                   | Not required                |
| U-NII Detection Bandwidth       | ✓                | Not required                   | ✓                           |

#### APPLICABILITY OF DFS REQUIREMENTS DURING NORMAL OPERATION

| Requirement                       | Operational Mode |                                |                             |
|-----------------------------------|------------------|--------------------------------|-----------------------------|
|                                   | Master           | Client without radar detection | Client with radar detection |
| DFS Detection Threshold           | ✓                | Not required                   | ✓                           |
| Channel Closing Transmission Time | ✓                | ✓                              | ✓                           |
| Channel Move Time                 | ✓                | ✓                              | ✓                           |
| U-NII Detection Bandwidth         | ✓                | Not required                   | ✓                           |

#### 5.1.2 Test Limits and Radar Signal Parameters

##### Detection Threshold Values

#### DFS DETECTION THRESHOLDS FOR MASTER DEVICES AND CLIENT DEVICES WITH RADAR DETECTION

| Maximum Transmit Power | Value (See Note 1 and 2) |
|------------------------|--------------------------|
| ≥ 200 milliwatt        | -64 dBm                  |
| < 200 milliwatt        | -62 dBm                  |

**Note 1:** This is the level at the input of the receiver assuming a 0 dBi receive antenna.

**Note 2:** Throughout these test procedures an additional 1 dB has been added to the amplitude of the test transmission waveforms to account for variations in measurement equipment. This will ensure that the test signal is at or above the detection threshold level to trigger a DFS response.

## DFS RESPONSE REQUIREMENT VALUES

| Parameter   | Value   |
|---|---|
| Non-occupancy period  | Minimum 30 minutes  |
| Channel Availability Check Time   | 60 seconds  |
| Channel Move Time   | 10 seconds<br>See Note 1.   |
| Channel Closing Transmission Time   | 200 milliseconds + an aggregate of 60 milliseconds over remaining 10 second period.<br>See Notes 1 and 2. |
| U-NII Detection Bandwidth   | 100% of the UNII transmission power bandwidth.<br>See Note 3.   |
| <p><b>Note 1:</b> The instant that the Channel Move Time and the Channel Closing Transmission Time begins is as follows:</p> <ul style="list-style-type: none"> <li>• For the Short Pulse Radar Test Signals this instant is the end of the Burst.</li> <li>• For the Frequency Hopping radar Test Signal, this instant is the end of the last radar Burst generated.</li> <li>• For the Long Pulse Radar Test Signal this instant is the end of the 12 second period defining the Radar Waveform.</li> </ul> <p><b>Note 2:</b> The Channel Closing Transmission Time is comprised of 200 milliseconds starting at the beginning of the Channel Move Time plus any additional intermittent control signals required to facilitate a Channel move (an aggregate of 60 milliseconds) during the remainder of the 10 second period. The aggregate duration of control signals will not count quiet periods in between transmissions.</p> <p><b>Note 3:</b> During the U-NII Detection Bandwidth detection test, radar type 1 is used and for each frequency step the minimum percentage of detection is 90 percent. Measurements are performed with no data traffic.</p> |   |

Parameters of DFS Test Signals

Step intervals of 0.1 microsecond for Pulse Width, 1 microsecond for PRI, 1 MHz for chirp width and 1 for the number of pulses will be utilized for the random determination of specific test waveforms.

## SHORT PULSE RADAR TEST WAVEFORMS

| Radar Type | Pulse Width (μsec) | PRI (μsec)   | Number of Pulses   | Minimum Percentage of Successful Detection | Minimum Number of Trials |
|------------|--------------------|--|--|--|--------------------------|
| 0          | 1                  | 1428   | 18   | See Note 1                                 | See Note 1               |
| 1          | 1                  | Test A: 15 unique PRI values randomly selected from the list of 23 PRI values in Table 5a<br>Test B: 15 unique PRI values randomly selected within the range of 518-3066 μsec, with a minimum increment of 1 μsec, excluding PRI values selected in Test A | $\text{Roundup} \left\{ \left( \frac{1}{360} \right) \cdot \left( \frac{19 \cdot 10^6}{\text{PRI}_{\mu\text{sec}}} \right) \right\}$ | 60%  | 30                       |
| 2          | 1-5                | 150-230  | 23-29  | 60%  | 30                       |
| 3          | 6-10               | 200-500  | 16-18  | 60%  | 30                       |
| 4          | 11-20              | 200-500  | 12-16  | 60%  | 30                       |

|  |     |     |
|--|-----|-----|
| Aggregate (Radar Types 1-4)  | 80% | 120 |
| Note 1: Short Pulse Radar Type 0 should be used for the detection bandwidth test, channel move time, and channel closing time tests. |     |     |

LONG PULSE RADAR TEST WAVEFORM

| Radar Type | Pulse Width (μsec) | Chirp Width (MHz) | PRI (μsec) | Number of Pulses per Burst | Number of Bursts | Minimum Percentage of Successful Detection | Minimum Number of Trials |
|------------|--------------------|-------------------|------------|----------------------------|------------------|--|--------------------------|
| 5          | 50-100             | 5-20              | 1000-2000  | 1-3                        | 8-20             | 80%  | 30                       |

FREQUENCY HOPPING RADAR TEST WAVEFORM

| Radar Type | Pulse Width (μsec) | PRI (μsec) | Pulses per Hop | Hopping Rate (kHz) | Hopping Sequence Length (msec) | Minimum Percentage of Successful Detection | Minimum Number of Trials |
|------------|--------------------|------------|----------------|--------------------|--------------------------------|--|--------------------------|
| 6          | 1                  | 333        | 9              | 0.333              | 300                            | 70%  | 30                       |

5.1.2.1 Test Setup

See 4.3 for test setup description for the radiated test. The photo of test setup please refer to ANNEX B.

5.1.2.2 Test Procedure

**DFS MEASUREMENT SYSTEM:**

A complete DFS Measurement System consists of two subsystems: (1) the Radar Signal Generating Subsystem and (2) the Traffic Monitoring Subsystem. The control PC is necessary for generating the Radar waveforms in Table 6, 7 and 8. The traffic monitoring subsystem is specified to the type of unit under test (UUT).

Conducted setup configuration of ADT DFS Measurement System

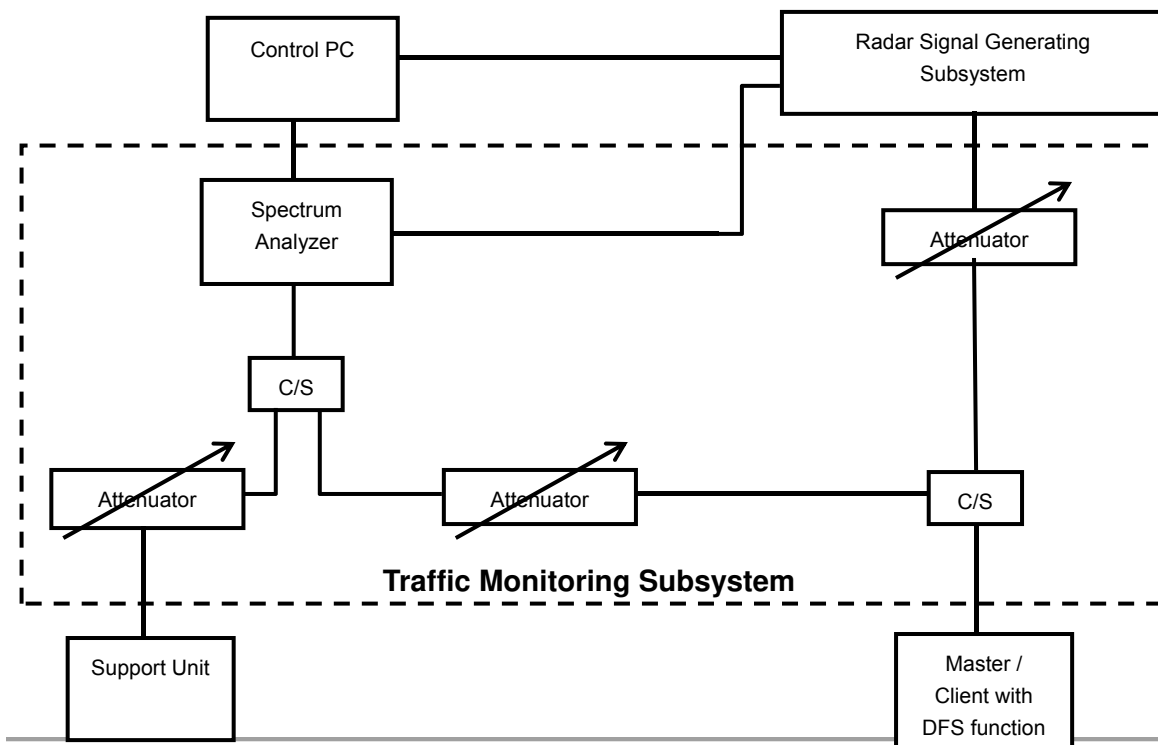

The test transmission will always be from the Master Device to the Client Device. While the Client device is set up to associate with the Master device and play the MPEG file (6 ½ Magic Hours) from Master device, the designated MPEG test file and instructions are located at: <http://ntiacsd.ntia.doc.gov/dfs/>.

**CALIBRATION OF DFS DETECTION THRESHOLD LEVEL:**

The measured channel is 5500 MHz in 20MHz Bandwidth and 5530MHz in 80MHz Bandwidth. The radar signal was the same as transmitted channels, and injected into the antenna port of AP (master) or Client Device with Radar Detection, measured the channel closing transmission time and channel move time. The Master antenna gain is 6.57dBi and required detection threshold is -54.43dBm (= -62 +1 +6.57)dBm. The calibrated conducted detection threshold level is set to -54.43 dBm.

Conducted setup configuration of Calibration of DFS Detection Threshold Level

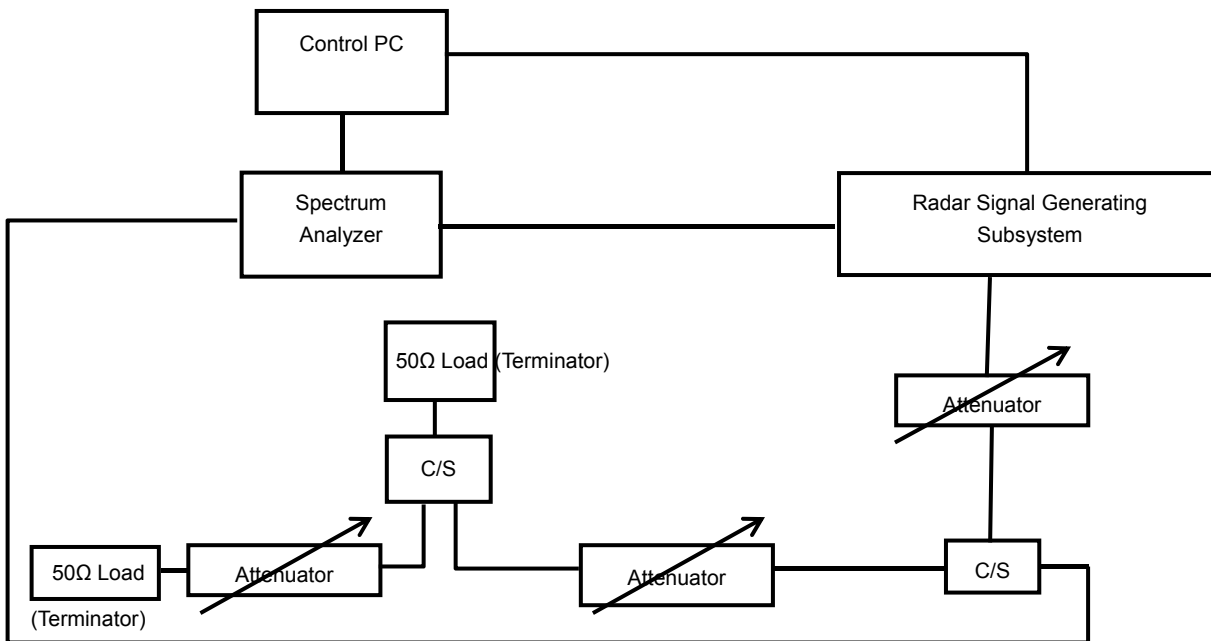

## Radar Waveform Calibration Result

## Radar Type 0 Calibration Plot (5290MHz)

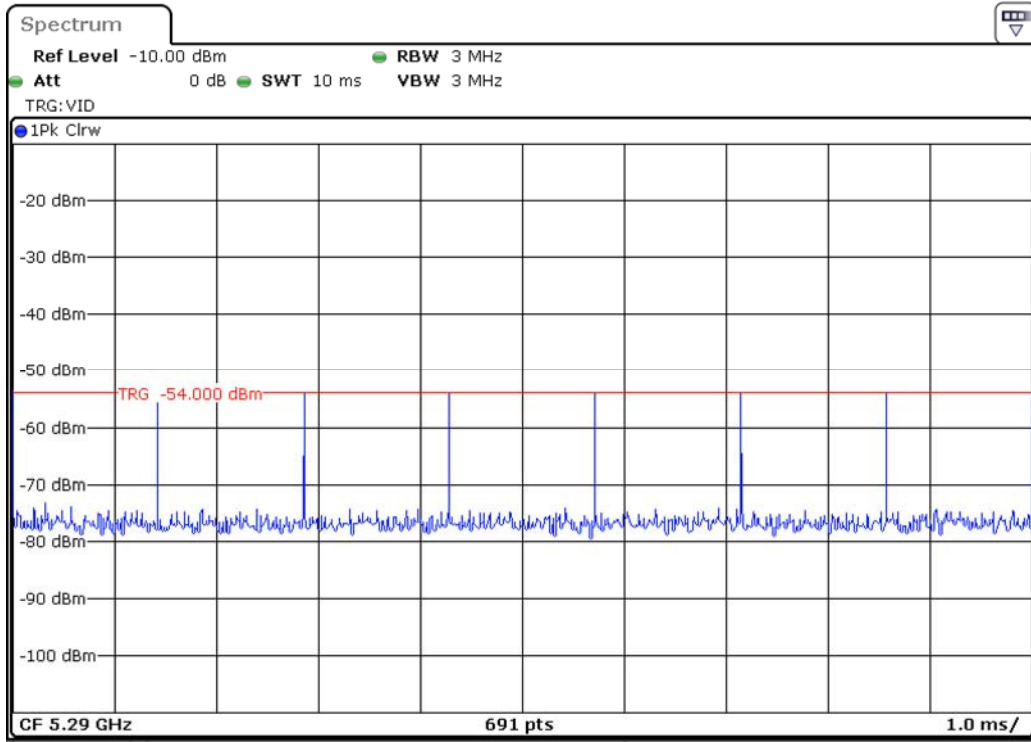

## Radar Type 1 test A Calibration Plot (5290MHz)

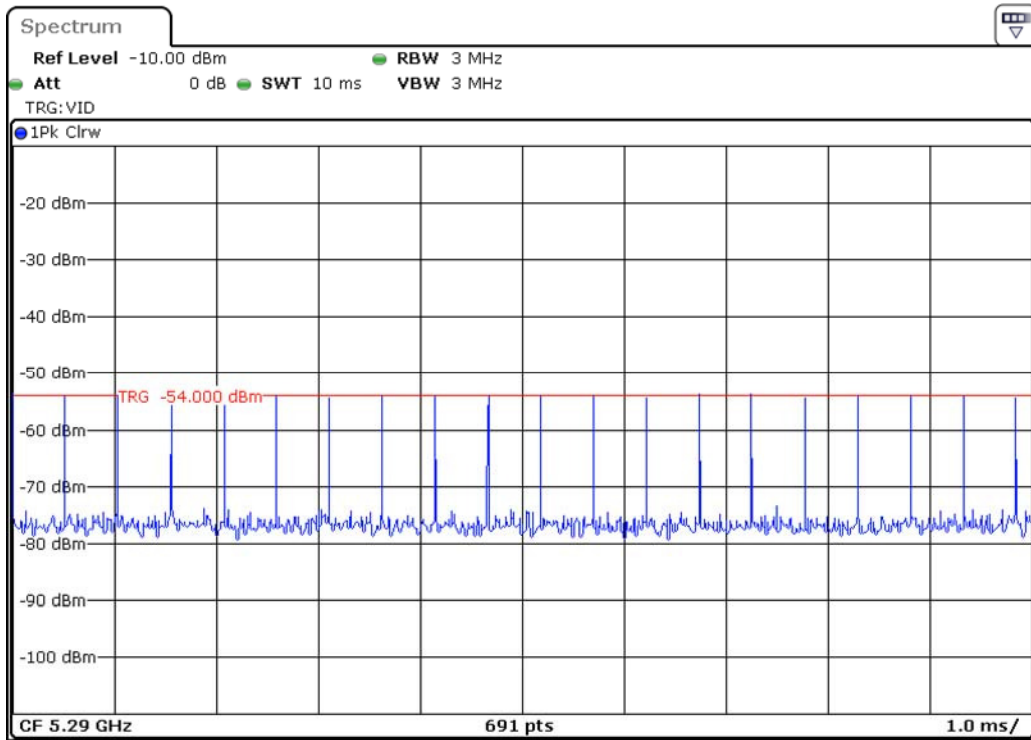



Radar Type 1 test B Calibration Plot (5290MHz)

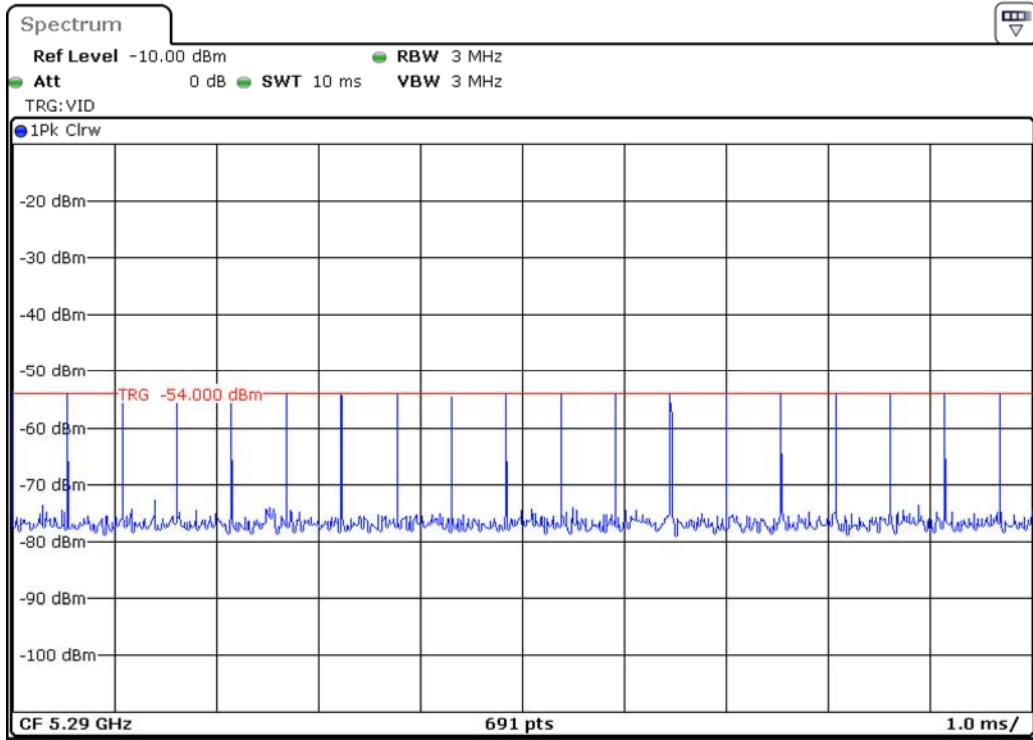

Radar Type 2 Calibration Plot (5290MHz)

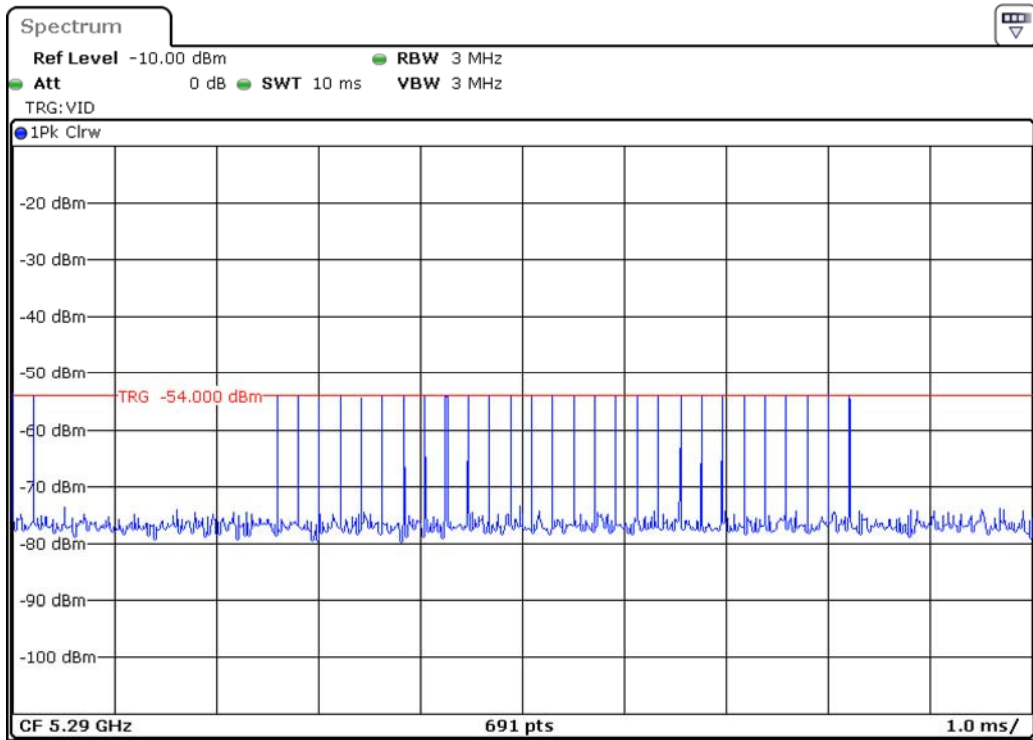

## Radar Type 3 Calibration Plot (5290MHz)

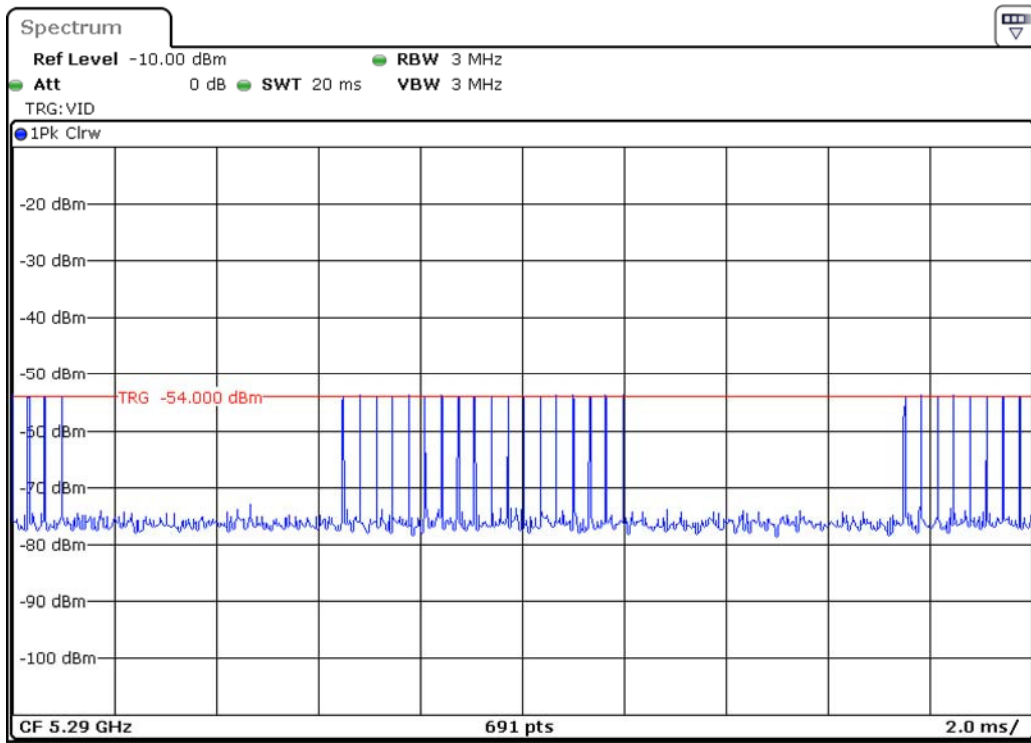

## Radar Type 4 Calibration Plot (5290MHz)

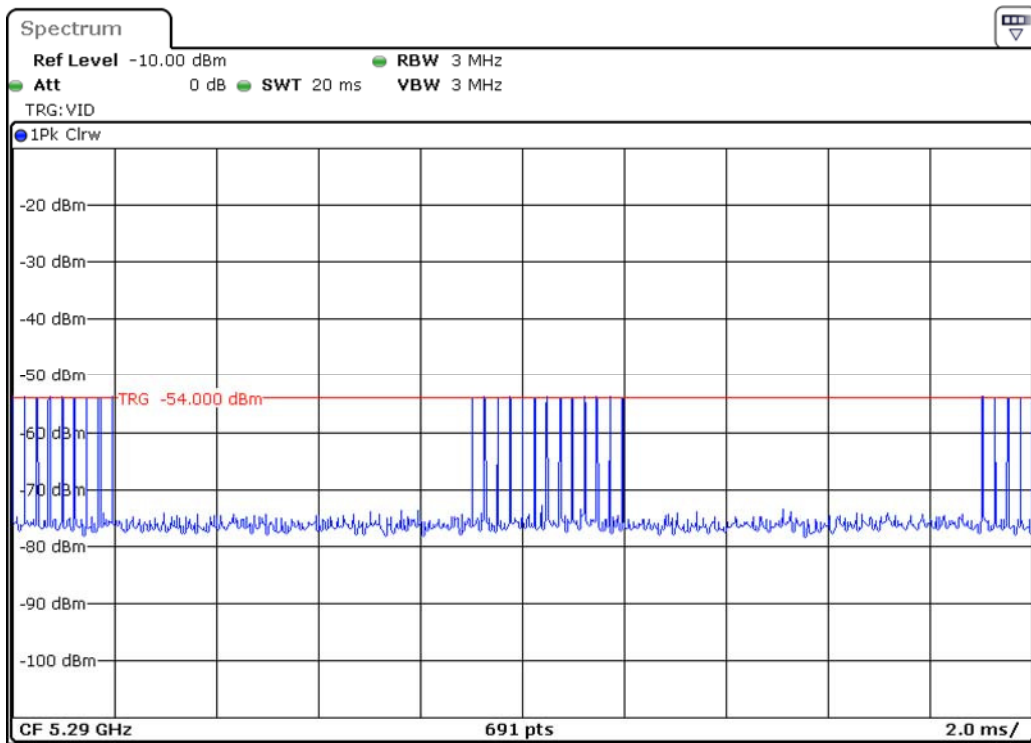

## Radar Type 5 Calibration Plot (5290MHz)

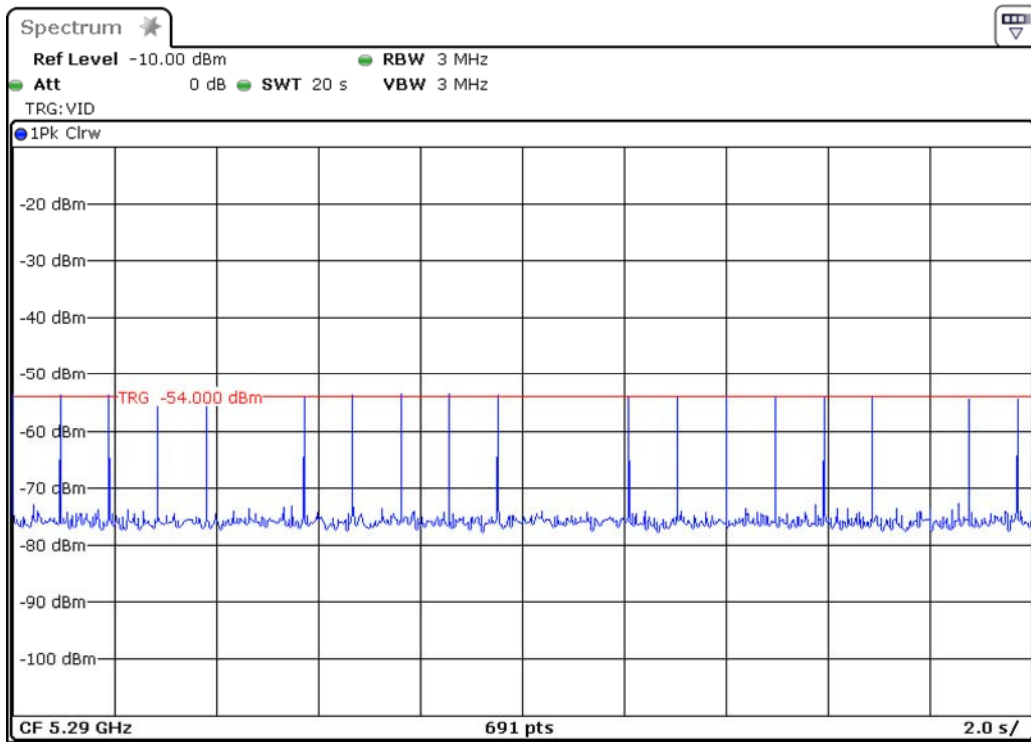

## Radar Type 6 Calibration Plot (5290MHz)

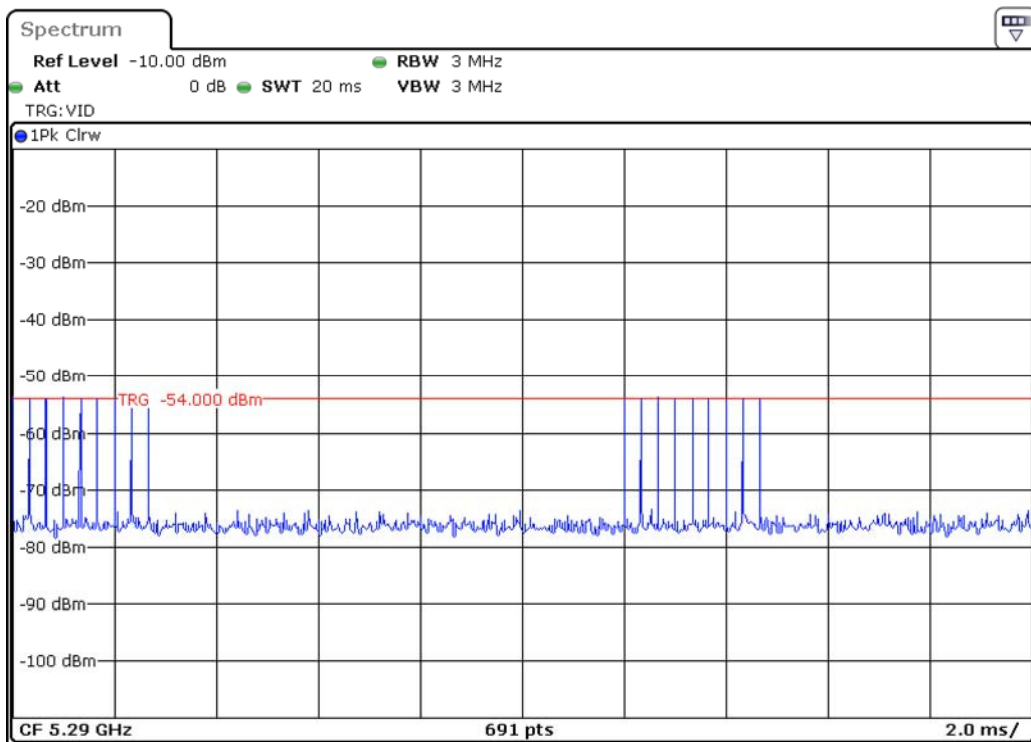

## 5.1.2.3 Test Result

Please refer to ANNEX A

## ANNEX A TEST RESULT

### A.1 CHANNEL CLOSING TRANSMISSION AND CHANNEL MOVE TIME

The timing plot of the channel loading

802.11ac Channel 58

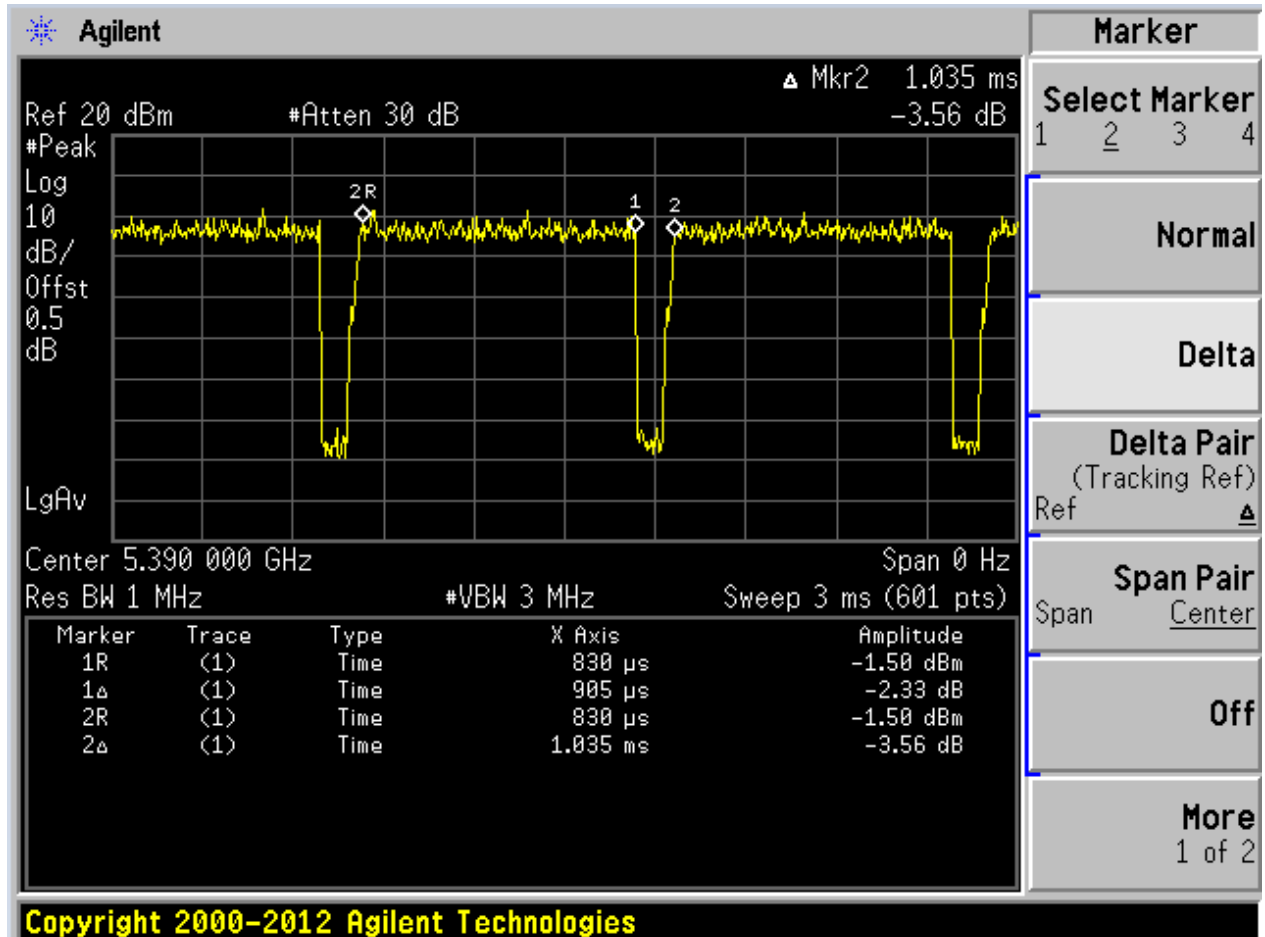

The channel loading Specification of Ton/ (Ton +Toff) as the file streaming between master to client is 87.4%.

Result of DFS Channel Shutdown

Note: The radar test signals are injected into the Master Device.

This test was investigated for different bandwidth (the lowest and the highest bandwidth). The following plots was done on 80MHz as a representative

| Description                       | Operation Mode   | Operation Channel | Value (s) | Limit   |
|-----------------------------------|------------------|-------------------|-----------|---|
| Channel Move Time                 | 802.11ac(80 MHz) | 58                | 4.3       | 10 s  |
| Channel Closing Transmission Time | 802.11ac(80 MHz) | 58                | 0.068     | 200 milliseconds + an aggregate of 60 milliseconds over remaining 10 second period. |
| Channel Move Time                 | 802.11ac(80 MHz) | 106               | 4.3       | 10 s  |
| Channel Closing Transmission Time | 802.11ac(80 MHz) | 106               | 0.061     | 200 milliseconds + an aggregate of 60 milliseconds over remaining 10 second period. |
| Test Verdict                      | Pass             |                   |           |   |

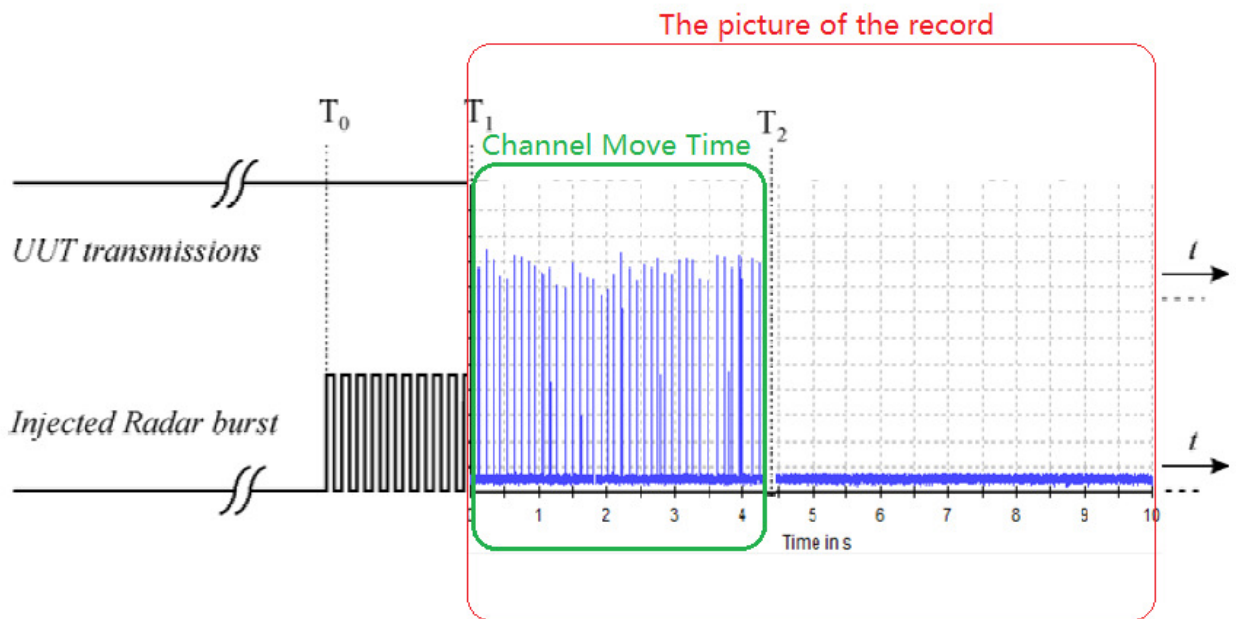

$T_0$  denotes DFS test signal start generated on the channel.

$T_1$  denotes the end of the radar burst.

$T_2$  denotes the instant when the UUT has ceased all transmissions on the channel.

The time difference between  $T_1$  and  $T_2$  shall be measured. This value (*Channel Move Time*) shall be noted and compared with the limit.

The aggregate duration (*Channel Closing Transmission Time*) of all transmissions from the UUT on Chr during the *Channel Move Time* shall be compared to the limit.

DFS Test schematic graphic

802.11ac Channel 58

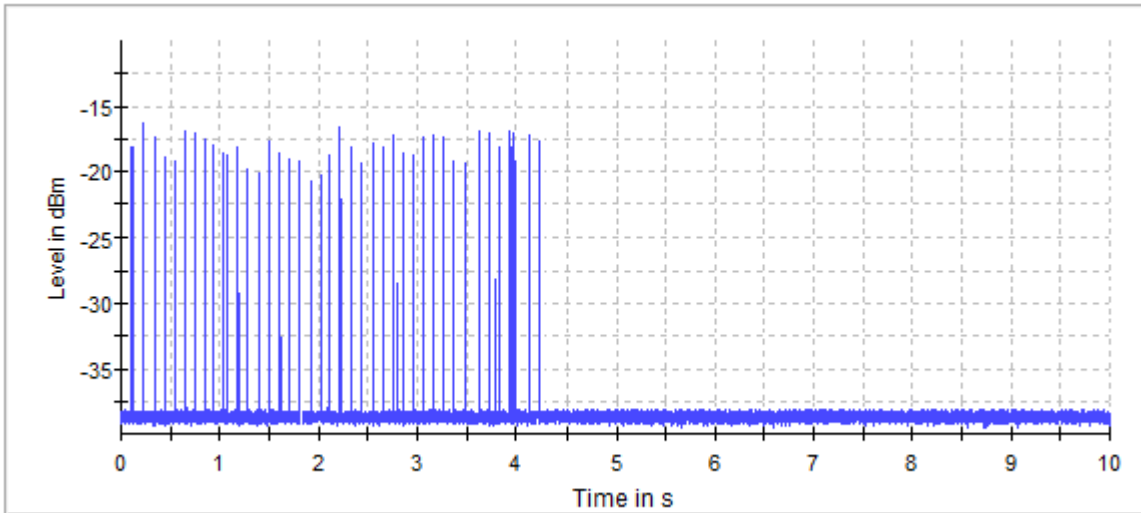

802.11ac 80 Channel 106

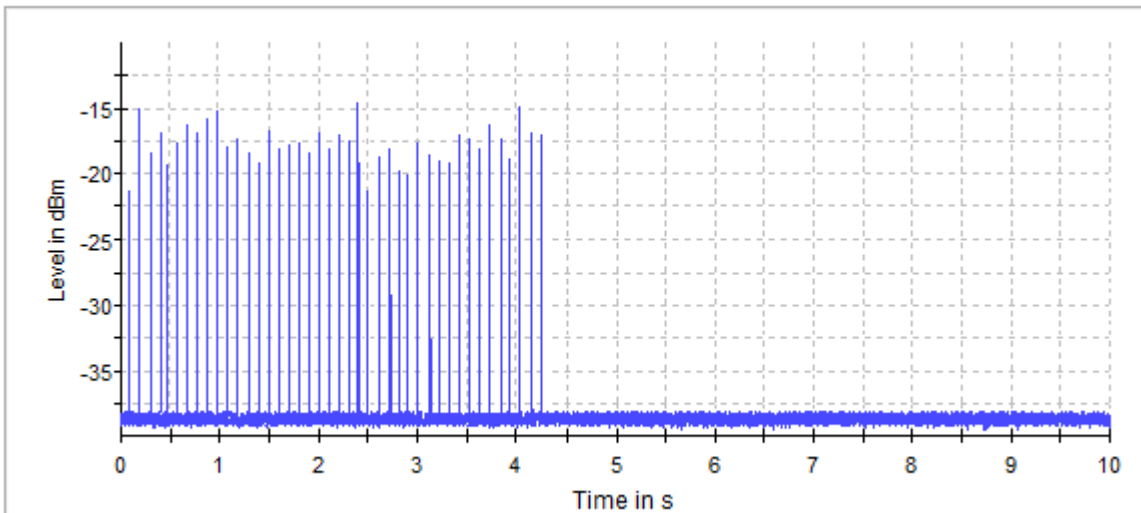



## A.2 NON- OCCUPANCY PERIOD

Master was off.

During the 30 minutes observation time, The UUT did not make any transmissions in the DFS band after UUT power up.

802.11ac (80 MHz) CH58

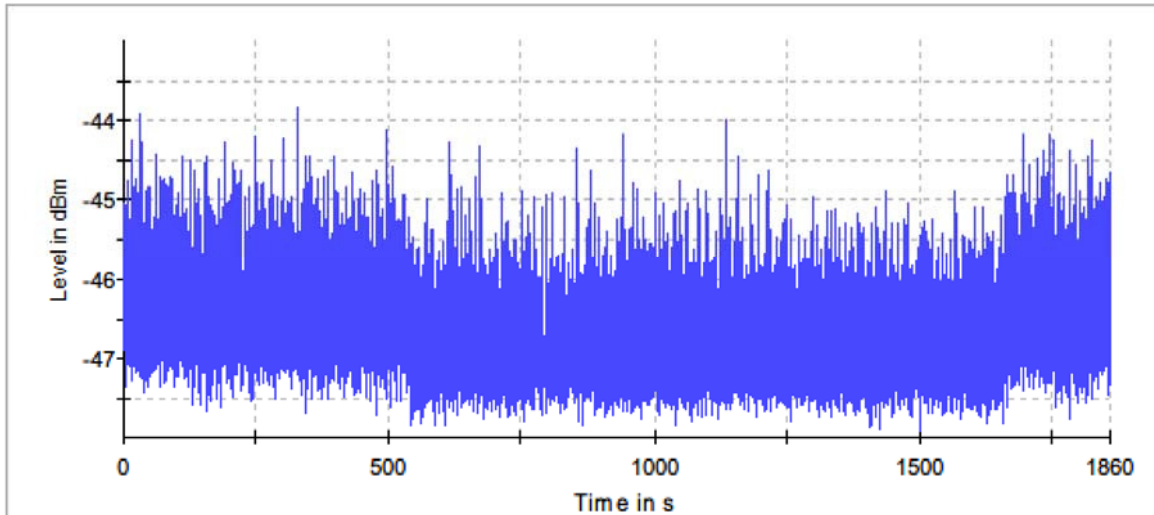

## **ANNEX B TEST SETUP PHOTOS**

Please refer the document “BL-SZ1680175-DFS.PDF”.

## **ANNEX C EUT EXTERNAL PHOTOS**

Please refer the document “BL-SZ1680175-AW.PDF”.

## **ANNEX D EUT INTERNAL PHOTOS**

Please refer the document “BL-SZ1680175-AI.PDF”.

--END OF REPORT--