



Test Report No.: RF161008W001-6



FCC TEST REPORT (WIFI 5G)

Product: LTE Digital Mobile Phone
Model No.: NX529J/ nubia Z11 mini
FCC ID: 2AHJO-NX529J
Applicant: Nubia Technology Co., Ltd.
10/F, Tower A, Hans Innovation Mansion, North Ring Rd.,
Address: No. 9018, Hi-Tech Industrial Park, Nanshan District,
Shenzhen, P.R.China
Manufacturer: Nubia Technology Co., Ltd.
10/F, Tower A, Hans Innovation Mansion, North Ring Rd.,
Address: No. 9018, Hi-Tech Industrial Park, Nanshan District,
Shenzhen, P.R.China
Prepared by: Bureau Veritas Shenzhen Co., Ltd. Dongguan Branch
Lab Location: No. 34, Chenwulu Section, Guantai Rd., Houjie Town,
Dongguan City, Guangdong 523942, China
TEL: +86 769 8593 5656
FAX: +86 769 8593 1080
E-MAIL: customerservice.dg@cn.bureauveritas.com
Report No.: RF161008W001-6
Received Date: Oct. 08, 2016
Test Date: Oct. 09, 2016 ~ Oct. 28, 2016
Issued Date: Oct. 30, 2016

This report should not be used by the client to claim product certification, approval, or endorsement by A2LA or any government agencies.

Any copying or replication of this report to or for any other person or entity, or use of our name or trademark, is permitted only with our prior written permission. This report sets forth our findings solely with respect to the test samples identified herein. The results set forth in this report are not indicative or representative of the quality or characteristics of the lot from which a test sample was taken or any similar or identical product unless specifically and expressly noted. Our report includes all of the tests requested by you and the results thereof based upon the information that you provided to us. You have 60 days from date of issuance of this report to notify us of any material error or omission caused by our negligence, provided, however, that such notice shall be in writing and shall specifically address the issue you wish to raise. A failure to raise such issue within the prescribed time shall constitute your unqualified acceptance of the completeness of this report, the tests conducted and the correctness of the report contents. Unless specific mention, the uncertainty of measurement has been explicitly taken into account to declare the compliance or non-compliance to the specification.

Bureau Veritas Shenzhen Co., Ltd.
Dongguan Branch

No. 34, Chenwulu Section, Guantai Rd., Houjie
Town, Dongguan City, Guangdong 523942, China

Tel: +86 769 8593 5656
Fax: +86 769 8593 1080
Email: customerservice.dg@cn.bureauveritas.com



TABLE OF CONTENTS

RELEASE CONTROL RECORD 4

1 CERTIFICATION 5

2 SUMMARY OF TEST RESULTS..... 6

 2.1 MEASUREMENT UNCERTAINTY 6

3 GENERAL INFORMATION 7

 3.1 GENERAL DESCRIPTION OF EUT 7

 3.2 DESCRIPTION OF TEST MODES 9

 3.2.1 TEST MODE APPLICABILITY AND TESTED CHANNEL DETAIL.....11

 3.3 DUTY CYCLE OF TEST SIGNAL 14

 3.4 DESCRIPTION OF SUPPORT UNITS 14

 3.4.1 CONFIGURATION OF SYSTEM UNDER TEST 16

 3.5 GENERAL DESCRIPTION OF APPLIED STANDARDS 16

4 TEST TYPES AND RESULTS 17

 4.1 RADIATED EMISSION AND BANDEDGE MEASUREMENT 17

 4.1.1 LIMITS OF RADIATED EMISSION AND BANDEDGE MEASUREMENT..... 17

 4.1.2 LIMITS OF UNWANTED EMISSION OUT OF THE RESTRICTED BANDS 17

 4.1.3 TEST INSTRUMENTS..... 18

 4.1.4 TEST PROCEDURES 19

 4.1.5 DEVIATION FROM TEST STANDARD 19

 4.1.6 TEST SETUP..... 20

 4.1.7 EUT OPERATING CONDITION 21

 4.1.8 TEST RESULTS 22

 4.2 CONDUCTED EMISSION MEASUREMENT 70

 4.2.1 LIMITS OF CONDUCTED EMISSION MEASUREMENT 70

 4.2.2 TEST INSTRUMENTS..... 70

 4.2.3 TEST PROCEDURES 70

 4.2.4 DEVIATION FROM TEST STANDARD 71

 4.2.5 TEST SETUP..... 71

 4.2.6 EUT OPERATING CONDITIONS 71

 4.2.7 TEST RESULTS 72



4.3	MAXIMUM CONDUCTED OUTPUT POWER MEASUREMENT	74
4.3.1	LIMITS OF MAXIMUM CONDUCTED OUTPUT POWER MEASUREMENT	74
4.3.2	TEST SETUP	74
4.3.3	TEST INSTRUMENTS.....	75
4.3.4	TEST PROCEDURE	75
4.3.5	DEVIATION FROM TEST STANDARD	76
4.3.6	EUT OPERATING CONDITIONS	76
4.3.7	TEST RESULTS	77
4.4	PEAK POWER SPECTRAL DENSITY MEASUREMENT	90
4.4.1	LIMITS OF PEAK POWER SPECTRAL DENSITY MEASUREMENT	90
4.4.2	TEST SETUP	90
4.4.3	TEST INSTRUMENTS.....	90
4.4.4	TEST PROCEDURES	91
4.4.5	DEVIATION FROM TEST STANDARD	91
4.4.6	EUT OPERATING CONDITIONS	91
4.4.7	TEST RESULTS	92
4.5	FREQUENCY STABILITY	95
4.5.1	LIMITS OF FREQUENCY STABILITY MEASUREMENT	99
4.5.2	TEST SETUP	99
4.5.3	TEST INSTRUMENTS.....	99
4.5.4	TEST PROCEDURE	100
4.5.5	DEVIATION FROM TEST STANDARD	100
4.5.6	EUT OPERATING CONDITION	100
4.5.7	TEST RESULTS	101
5	PHOTOGRAPHS OF THE TEST CONFIGURATION	103
6	APPENDIX A – MODIFICATIONS RECORDERS FOR ENGINEERING CHANGES TO THE EUT BY THE LAB	104



**BUREAU
VERITAS**

Test Report No.: RF161008W001-6

RELEASE CONTROL RECORD

ISSUE NO.	REASON FOR CHANGE	DATE ISSUED
RF161008W001-6	Original release	Oct. 30, 2016



1 CERTIFICATION

PRODUCT: LTE Digital Mobile Phone
BRAND NAME: Nubia
MODEL NO.: NX529J/ nubia Z11 mini
APPLICANT: Nubia Technology Co., Ltd.
TESTED: Oct. 09, 2016 ~ Oct. 28, 2016
TEST SAMPLE: Identical Prototype
STANDARDS: **FCC Part 15, Subpart E (15.407), Section 15.407**
ANSI C63.10-2013

The above equipment has been tested by **Bureau Veritas Shenzhen Co., Ltd. Dongguan Branch** and found compliance with the requirement of the above standards. The test record, data evaluation & Equipment Under Test (EUT) configurations represented herein are true and accurate accounts of the measurements of the sample's EMC characteristics under the conditions specified in this report.

PREPARED BY : Yuqiang Yin , **DATE:** Oct. 30, 2016
(Yuqiang Yin / Engineer)

APPROVED BY : Bill Yao , **DATE:** Oct. 30, 2016
(Bill Yao / Manager)



2 SUMMARY OF TEST RESULTS

The EUT has been tested according to the following specifications:

APPLIED STANDARD: FCC PART 15, SUBPART E (SECTION 15.407)			
STANDARD SECTION	TEST TYPE AND LIMIT	RESULT	REMARK
15.407(b)(5)	AC Power Conducted Emission	PASS	Meet the requirement of limit. Minimum passing margin is 14.09dB at 0.412000MHz.
15.407(b) (1/2/3/4/6)	Radiated Emission & Band Edge Measurement	PASS	Meet the requirement of limit. Minimum passing margin is -0.90dB at 5147MHz.
15.407(a/1/2/3)	Maximum conducted output Power	PASS	Meet the requirement of limit.
15.407(a/1/2/3)	Peak Power Spectral Density	PASS	Meet the requirement of limit.
15.407(e)	6 dB Bandwidth	PASS	Meet the requirement of limit. (U-NII-3 Band only)
15.407(g)	Frequency Stability	PASS	Meet the requirement of limit.
15.203	Antenna Requirement	PASS	No antenna connector is used.

2.1 MEASUREMENT UNCERTAINTY

Where relevant, the following measurement uncertainty levels have been estimated for tests performed on the EUT as specified in CISPR 16-4-2:

MEASUREMENT	FREQUENCY	UNCERTAINTY
Conducted emissions	9kHz~30MHz	2.66dB
Radiated emissions	9KHz ~ 30MHz	2.74dB
	30MHz ~ 1GMHz	3.55dB
	1GHz ~ 18GHz	4.84dB
	18GHz ~ 40GHz	1.94dB

This uncertainty represents an expanded uncertainty expressed at approximately the 95% confidence level using a coverage factor of k = 2.



3 GENERAL INFORMATION

3.1 GENERAL DESCRIPTION OF EUT

EUT	LTE Digital Mobile Phone
MODEL NO.	NX529J/ nubia Z11 mini
POWER SUPPLY	5.0Vdc (adapter or host equipment) 3.85Vdc (battery)
MODULATION TYPE	64QAM, 16QAM, QPSK, BPSK
MODULATION TECHNOLOGY	OFDM
TRANSFER RATE	802.11a: 54.0/ 48.0/ 36.0/ 24.0/ 18.0/ 12.0/ 9.0/ 6.0Mbps 802.11n: up to MCS7 802.11ac: up to 390.0Mbps
OPERATING FREQUENCY	5180 ~ 5240MHz, 5260 ~ 5320MHz 5500 ~ 5700MHz, 5745 ~ 5825MHz
NUMBER OF CHANNEL	5180 ~ 5240MHz: 4 for 802.11a, 802.11n (20MHz) 2 for 802.11n (40MHz) 1 for 802.11ac (80MHz) 5260 ~ 5320MHz: 4 for 802.11a, 802.11n (20MHz) 2 for 802.11n (40MHz) 1 for 802.11ac (80MHz) 5500 ~ 5700MHz: 8 for 802.11a, 802.11n (20MHz) 3 for 802.11n (40MHz) 1 for 802.11ac (80MHz) 5745 ~ 5825MHz: 5 for 802.11a, 802.11n (20MHz) 2 for 802.11n (40MHz) 1 for 802.11ac (80MHz)
AVERAGE POWER	30.903mW for 5180 ~ 5240MHz 28.445mW for 5260 ~ 5320MHz 29.174mW for 5500 ~ 5700MHz 27.479mW for 5745 ~ 5825MHz
ANTENNA TYPE	5180 ~ 5240MHz: PIFA Antenna with 2dBi gain 5260 ~ 5320MHz: PIFA Antenna with 2dBi gain 5500 ~ 5700MHz: PIFA Antenna with 2dBi gain 5745 ~ 5825MHz: PIFA Antenna with 2dBi gain
I/O PORTS	Refer to user's manual
CABLE SUPPLIED	USB cable: non-shielded, detachable, 1.0m

NOTE:

- For a more detailed features description, please refer to the manufacturer's specifications or the user's



- manual.
- 2. The EUT was powered by the following adapters:

ADAPTER 1	
BRAND:	RUIDE
MODEL:	STC-A515A-Z
INPUT:	AC 100-240V, 600mA
OUTPUT:	DC 5V, 1500mA

ADAPTER 2	
BRAND:	DOKOCOM
MODEL:	STC-A515A-Z
INPUT:	AC 100-240V, 600mA
OUTPUT:	DC 5V, 1500mA

ADAPTER 3	
BRAND:	Salcomp
MODEL:	STC-A515A-Z
INPUT:	AC 100-240V, 600mA
OUTPUT:	DC 5V, 1500mA

- 3. The EUT matched the following USB cable:

USB CABLE	
BRAND:	LIXUN
MODEL:	ZXMT1511003
SIGNAL LINE:	1.0 METER

- 4. The EUT incorporates a SISO function. Physically, the EUT provides one completed transmitter and one receiver.

MODULATION MODE	TX FUNCTION
802.11a	1TX/1RX
802.11n (20MHz)	1TX/1RX
802.11n (40MHz)	1TX/1RX
802.11ac (80MHz)	1TX/1RX

- 5. The above models are identical except the model name for marketing purpose.
- 6. For the test results, the EUT had been tested with all conditions. But only the worst case was shown in test report.



3.2 DESCRIPTION OF TEST MODES

FOR 5150 ~ 5250MHz

4 channels are provided for 802.11a, 802.11n (20MHz):

CHANNEL	FREQUENCY	CHANNEL	FREQUENCY
36	5180 MHz	44	5220 MHz
40	5200 MHz	48	5240 MHz

2 channels are provided for 802.11n (40MHz):

CHANNEL	FREQUENCY	CHANNEL	FREQUENCY
38	5190 MHz	46	5230 MHz

1 channel is provided for 802.11ac (80MHz):

CHANNEL	FREQUENCY	CHANNEL	FREQUENCY
42	5210 MHz		

FOR 5250 ~ 5350MHz

4 channels are provided for 802.11a, 802.11n (20MHz):

CHANNEL	FREQUENCY	CHANNEL	FREQUENCY
52	5260 MHz	60	5300 MHz
56	5280 MHz	64	5320 MHz

2 channels are provided for 802.11n (40MHz):

CHANNEL	FREQUENCY	CHANNEL	FREQUENCY
54	5270 MHz	62	5310 MHz

1 channel is provided for 802.11ac (80MHz):

CHANNEL	FREQUENCY	CHANNEL	FREQUENCY
58	5290 MHz		



FOR 5470 ~ 5725MHz

8 channels are provided for 802.11a, 802.11n (20MHz):

CHANNEL	FREQUENCY	CHANNEL	FREQUENCY
100	5500 MHz	116	5580 MHz
104	5520 MHz	132	5660 MHz
108	5540 MHz	136	5680 MHz
112	5560 MHz	140	5700 MHz

3 channels are provided for 802.11n (40MHz):

CHANNEL	FREQUENCY	CHANNEL	FREQUENCY
102	5510 MHz	134	5670 MHz
110	5550 MHz		

1 channel is provided for 802.11ac (80MHz):

CHANNEL	FREQUENCY	CHANNEL	FREQUENCY
106	5530 MHz		

FOR 5725 ~ 5825MHz

4 channels are provided for 802.11a, 802.11n (20MHz):

CHANNEL	FREQUENCY	CHANNEL	FREQUENCY
149	5745 MHz	161	5805 MHz
153	5765 MHz	165	5825 MHz
157	5785 MHz		

2 channels are provided for 802.11n (40MHz):

CHANNEL	FREQUENCY	CHANNEL	FREQUENCY
151	5755 MHz	159	5795 MHz

1 channel is provided for 802.11ac (80MHz):

CHANNEL	FREQUENCY	CHANNEL	FREQUENCY
155	5775 MHz		



3.2.1 TEST MODE APPLICABILITY AND TESTED CHANNEL DETAIL

EUT CONFIGURE MODE	APPLICABLE TO				DESCRIPTION
	RE≥1G	RE<1G	PLC	APCM	
A	√	√	√	-	Powered by Adapter with wifi(5G) link
B	-	-	-	√	Powered by Battery with wifi(5G) link
C	-	-	-	-	Powered by USB with wifi(5G) link

Where **RE≥1G**: Radiated Emission above 1GHz **RE<1G**: Radiated Emission below 1GHz
PLC: Power Line Conducted Emission **APCM**: Antenna Port Conducted Measurement

NOTE:
The EUT had been pre-tested on the positioned of each 3 axis. The worst case was found when positioned on **X-plane**.
NOTE: "-" means no effect.

RADIATED EMISSION TEST (ABOVE 1GHz):

- Pre-Scan has been conducted to determine the worst-case mode from all possible combinations between available modulations, data rates and antenna ports (if EUT with antenna diversity architecture).
- Following channel(s) was (were) selected for the final test as listed below.

EUT CONFIGURE MODE	MODE	FREQ. BAND (MHz)	AVAILABLE CHANNEL	TESTED CHANNEL	MODULATION TECHNOLOGY	MODULATION TYPE	DATA RATE (Mbps)
A	802.11a	5180-5240	36 to 48	36, 44, 48	OFDM	BPSK	6.0
A	802.11n (20MHz)		36 to 48	36, 44, 48	OFDM	BPSK	MCS0
A	802.11n (40MHz)		38 to 46	38, 46	OFDM	BPSK	MCS0
A	802.11ac (80MHz)		42	42	OFDM	BPSK	V0
A	802.11a	5260-5320	52 to 64	52, 60, 64	OFDM	BPSK	6.0
A	802.11n (20MHz)		52 to 64	52, 60, 64	OFDM	BPSK	MCS0
A	802.11n (40MHz)		54 to 62	54, 62	OFDM	BPSK	MCS0
A	802.11ac (80MHz)		58	58	OFDM	BPSK	V0
A	802.11a	5500-5700	100 to 140	100, 116, 140	OFDM	BPSK	6.0
A	802.11n (20MHz)		100 to 140	100, 116, 140	OFDM	BPSK	MCS0
A	802.11n (40MHz)		102 to 134	102, 110, 134	OFDM	BPSK	MCS0
A	802.11ac (80MHz)		106	106	OFDM	BPSK	V0
A	802.11a	5725-5825	149 to 165	149, 157, 165	OFDM	BPSK	6.0
A	802.11n (20MHz)		149 to 165	149, 157, 165	OFDM	BPSK	MCS0
A	802.11n (40MHz)		151 to 159	151, 159	OFDM	BPSK	MCS0
A	802.11ac (80MHz)		155	155	OFDM	BPSK	V0

RADIATED EMISSION TEST (BELOW 1GHz):

- Pre-Scan has been conducted to determine the worst-case mode from all possible combinations between available modulations, data rates and antenna ports (if EUT with antenna diversity architecture).



Following channel(s) was (were) selected for the final test as listed below.

EUT CONFIGURE MODE	MODE	FREQ. BAND (MHz)	AVAILABLE CHANNEL	TESTED CHANNEL	MODULATION TECHNOLOGY	MODULATION TYPE	DATA RATE (Mbps)
A	802.11ac	5180-5240	42	42	OFDM	BPSK	V0

POWER LINE CONDUCTED EMISSION TEST:

Pre-Scan has been conducted to determine the worst-case mode from all possible combinations between available modulations, data rates and antenna ports (if EUT with antenna diversity architecture).

Following channel(s) was (were) selected for the final test as listed below.

EUT CONFIGURE MODE	MODE	FREQ. BAND (MHz)	AVAILABLE CHANNEL	TESTED CHANNEL	MODULATION TECHNOLOGY	MODULATION TYPE	DATA RATE (Mbps)
A	802.11ac	5180-5240	42	42	OFDM	BPSK	V0

BANDEDGE MEASUREMENT:

Pre-Scan has been conducted to determine the worst-case mode from all possible combinations between available modulations, data rates and antenna ports (if EUT with antenna diversity architecture).

Following channel(s) was (were) selected for the final test as listed below.

EUT CONFIGURE MODE	MODE	FREQ. BAND (MHz)	AVAILABLE CHANNEL	TESTED CHANNEL	MODULATION TECHNOLOGY	MODULATION TYPE	DATA RATE (Mbps)
A	802.11a	5180-5240	36 to 48	36, 48	OFDM	BPSK	6.0
A	802.11n (20MHz)		36 to 48	36, 48	OFDM	BPSK	MCS0
A	802.11n (40MHz)		38 to 46	38, 46	OFDM	BPSK	MCS0
A	802.11ac (80MHz)		42	42	OFDM	BPSK	V0
A	802.11a	5260-5320	52 to 64	52, 64	OFDM	BPSK	6.0
A	802.11n (20MHz)		52 to 64	52, 64	OFDM	BPSK	MCS0
A	802.11n (40MHz)		54 to 62	54, 62	OFDM	BPSK	MCS0
A	802.11ac (80MHz)		58	58	OFDM	BPSK	V0
A	802.11a	5500-5700	100 to 140	100, 140	OFDM	BPSK	6.0
A	802.11n (20MHz)		100 to 140	100, 140	OFDM	BPSK	MCS0
A	802.11n (40MHz)		102 to 134	102, 134	OFDM	BPSK	MCS0
A	802.11ac (80MHz)		106	106	OFDM	BPSK	V0
A	802.11a	5725-5825	149 to 165	149, 165	OFDM	BPSK	6.0
A	802.11n (20MHz)		149 to 165	149, 165	OFDM	BPSK	MCS0
A	802.11n (40MHz)		151 to 159	151, 159	OFDM	BPSK	MCS0
A	802.11ac (80MHz)		155	155	OFDM	BPSK	V0



ANTENNA PORT CONDUCTED MEASUREMENT:

- This item includes all test value of each mode, but only includes spectrum plot of worst value of each mode.
- Pre-Scan has been conducted to determine the worst-case mode from all possible combinations between available modulations, data rates and antenna ports (if EUT with antenna diversity architecture).
- Following channel(s) was (were) selected for the final test as listed below.

EUT CONFIGURE MODE	MODE	FREQ. BAND (MHz)	AVAILABLE CHANNEL	TESTED CHANNEL	MODULATION TECHNOLOGY	MODULATION TYPE	DATA RATE (Mbps)
B	802.11a	5180-5240	36 to 48	36, 40, 48	OFDM	BPSK	6.0
B	802.11n (20MHz)		36 to 48	36, 40, 48	OFDM	BPSK	MCS0
B	802.11n (40MHz)		38 to 46	38, 46	OFDM	BPSK	MCS0
B	802.11ac (80MHz)		42	42	OFDM	BPSK	V0
B	802.11a	5260-5320	52 to 64	52, 60, 64	OFDM	BPSK	6.0
B	802.11n (20MHz)		52 to 64	52, 60, 64	OFDM	BPSK	MCS0
B	802.11n (40MHz)		54 to 62	54, 62	OFDM	BPSK	MCS0
B	802.11ac (80MHz)		58	58	OFDM	BPSK	V0
B	802.11a	5500-5700	100 to 140	100, 116, 140	OFDM	BPSK	6.0
B	802.11n (20MHz)		100 to 140	100, 116, 140	OFDM	BPSK	MCS0
B	802.11n (40MHz)		102 to 134	102, 110, 134	OFDM	BPSK	MCS0
B	802.11ac (80MHz)		106	106	OFDM	BPSK	V0
B	802.11a	5725-5825	149 to 165	149, 165	OFDM	BPSK	6.0
B	802.11n (20MHz)		149 to 165	149, 165	OFDM	BPSK	MCS0
B	802.11n (40MHz)		151 to 159	151, 159	OFDM	BPSK	MCS0
B	802.11ac (80MHz)		155	155	OFDM	BPSK	V0

TEST CONDITION:

APPLICABLE TO	ENVIRONMENTAL CONDITIONS	INPUT POWER	TESTED BY
RE<1G	23deg. C, 62%RH	DC 5V By Adapter	Tony
RE≥1G	23deg. C, 62%RH	DC 5V By Adapter	Tony
PLC	24deg. C, 61%RH	DC 5V By Adapter	Yuqiang Yin
APCM	23.5deg. C, 60%RH	DC 3.85V By battery	Yuqiang Yin



3.3 DUTY CYCLE OF TEST SIGNAL

Duty cycle of test signal is < 98%, duty factor shall be considered.

802.11a: Duty cycle = 1.356/1.577 = 0.860, Duty factor = 10 * log(1/0.860) = 0.66

802.11n (20MHz): Duty cycle = 1.269/1.469 = 0.864, Duty factor = 10 * log(1/0.864) = 0.64

802.11n (40MHz): Duty cycle = 0.630/0.834 = 0.755, Duty factor = 10 * log(1/0.755) = 1.22

802.11ac (80MHz): Duty cycle = 0.246/0.456 = 0.539, Duty factor = 10 * log(1/0.539) = 2.68

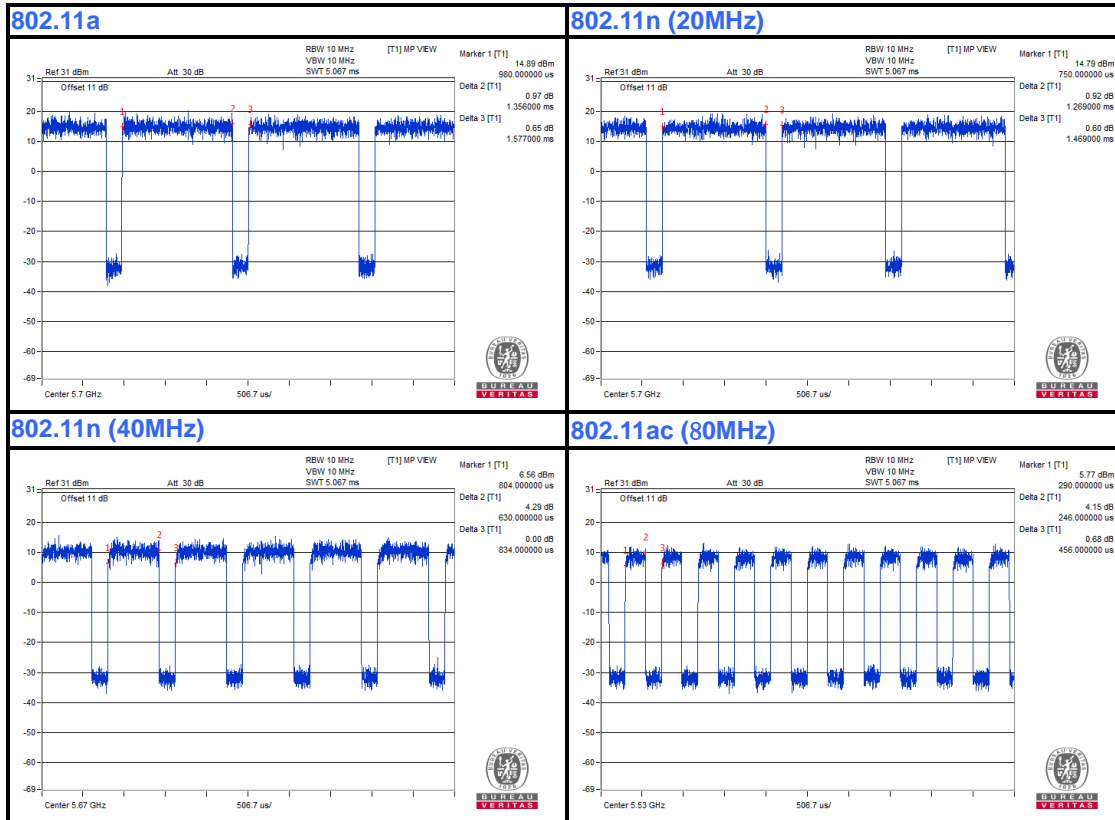



3.4 DESCRIPTION OF SUPPORT UNITS

The EUT has been tested as an independent unit together with other necessary accessories or support units. The following support units or accessories were used to form a representative test configuration during the tests.

NO.	PRODUCT	BRAND	MODEL NO.	SERIAL NO.	FCC ID
1	DC source	LONG WEI	PS-6403D	010934269	N/A
2	PC	HP	A6608CN	3CR83825X3	N/A

NO.	SIGNAL CABLE DESCRIPTION OF THE ABOVE SUPPORT UNITS
1	DC Line: Unshielded, Detachable 1.0m
2	AC Line: Unshielded, Detachable 1.5m

NOTE:

1. All power cords of the above support units are non shielded (1.8m).



3.4.1 CONFIGURATION OF SYSTEM UNDER TEST

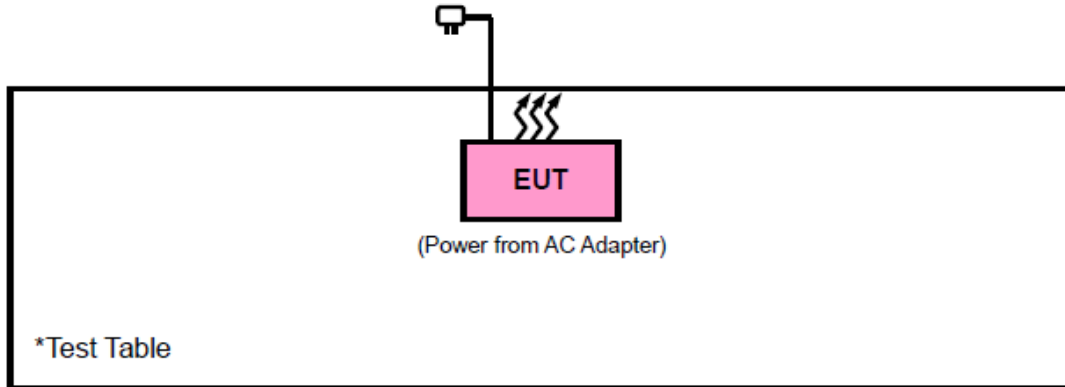

3.5 GENERAL DESCRIPTION OF APPLIED STANDARDS

The EUT is a RF Product. According to the specifications of the manufacturer, it must comply with the requirements of the following standards:

FCC Part 15, Subpart E (15.407)

KDB 789033 D02 General U-NII Test Procedures New Rules v01r02

ANSI C63.10-2013

All test items have been performed and recorded as per the above standards.

NOTE: The EUT is also considered as a kind of computer peripheral, because the connection to computer is necessary for typical use. It has been verified to comply with the requirements of FCC Part 15, Subpart B, Class B (Certification). The test report has been issued separately.



4 TEST TYPES AND RESULTS

4.1 RADIATED EMISSION AND BANDEDGE MEASUREMENT

4.1.1 LIMITS OF RADIATED EMISSION AND BANDEDGE MEASUREMENT

Radiated emissions which fall in the restricted bands must comply with the radiated emission limits specified as below table:

FREQUENCIES (MHz)	FIELD STRENGTH (microvolts/meter)	MEASUREMENT DISTANCE (meters)
0.009 ~ 0.490	2400/F(kHz)	300
0.490 ~ 1.705	24000/F(kHz)	30
1.705 ~ 30.0	30	30
30 ~ 88	100	3
88 ~ 216	150	3
216 ~ 960	200	3
Above 960	500	3

NOTE:

1. The lower limit shall apply at the transition frequencies.
2. Emission level (dBuV/m) = 20 log Emission level (uV/m).
3. For frequencies above 1000MHz, the field strength limits are based on average detector, however, the peak field strength of any emission shall not exceed the maximum permitted average limits, specified above by more than 20dB under any condition of modulation.

4.1.2 LIMITS OF UNWANTED EMISSION OUT OF THE RESTRICTED BANDS

APPLICABLE TO	LIMIT	
789033 D02 General UNII Test Procedures New Rules v01r02	FIELD STRENGTH AT 3m (dBµV/m)	
	PK : 74	AV : 54
APPLICABLE TO	EIRP LIMIT (dBm/MHz)	EQUIVALENT FIELD STRENGTH AT 3m (dBµV/m)
15.407(b)(1)	PK : -27	PK : 68.3
15.407(b)(2)		
15.407(b)(3)		
15.407(b)(4)	See note 2 (FCC 16-24)	



NOTE: The following formula is used to convert the equipment isotropic radiated power (eirp) to field strength:

$$E = \frac{1000000\sqrt{30P}}{3} \text{ } \mu\text{V/m, where P is the eirp (Watts).}$$

2. All emissions shall be limited to a level of -27 dBm/MHz at 75 MHz or more above or below the band edge increasing linearly to 10 dBm/MHz at 25 MHz above or below the band edge, and from 25 MHz above or below the band edge increasing linearly to a level of 15.6 dBm/MHz at 5 MHz above or below the band edge, and from 5 MHz above or below the band edge increasing linearly to a level of 27 dBm/MHz at the band edge.

4.1.3 TEST INSTRUMENTS

Equipment	Manufacturer	Model No.	Serial No.	Last Cal.	Next Cal.
EMI Test Receiver	Rohde&Schwarz	ESR7	101494	Apr. 05,16	Apr. 04,17
Signal and Spectrum Analyzer	Rohde&Schwarz	FSV7	102331	Nov. 09,15	Nov. 08,16
Bilog Antenna	Teseq	CBL 6111D	30643	Jul. 14, 16	Jul. 13, 17
Horn Antenna (1GHz -18GHz)	ETS -Lindgren	3117	00062558	May 18,16	May 17,17
3m Semi-anechoic Chamber	ETS-LINDGREN	9m*6m*6m	NSEMC003	Mar. 12,16	Mar. 11,18
Test Software	ADT	ADT_Radiated_V7.6.15.9.2	N/A	N/A	N/A
Horn Antenna	SCHWARZBECK	BBHA 9170	BBHA9170242	Mar. 12,16	Mar. 11,17
Amplifier (9kHz-1GHz)	SONOMA	310D	186955	Mar. 04,16	Mar. 03, 17
Pre-Amplifier(1-18G)	HP	8449B	3008A00409	Apr. 25,16	Apr. 24,17
Pre-Amplifier (18GHz-40GHz)	EMCI	EMC 184045	980102	Nov. 20,15	Nov. 19,16
BLUETOOTH TESTER	Rohde&Schwarz	CBT32	100811	Aug. 08,16	Aug. 07,17

NOTE:

1. The calibration interval of the above test instruments is 12 months and the calibrations are traceable to CEPREI/CHINA, GRGT/CHINA and NIM/CHINA.
2. The test was performed in 966 Chamber.
3. The FCC Site Registration No. is 502831.



4.1.4 TEST PROCEDURES

- a. The EUT was placed on the top of a rotating table 0.8 meters (for below 1GHz) / 1.5 meters (for above 1GHz) above the ground at 3 meter chamber room for test. The table was rotated 360 degrees to determine the position of the highest radiation.
- b. The EUT was set 3 meters away from the interference-receiving antenna, which was mounted on the top of a variable-height antenna tower.
- c. The antenna is a broadband antenna, and its height is varied from one meter to four meters above the ground to determine the maximum value of the field strength. Both horizontal and vertical polarizations of the antenna are set to make the measurement.
- d. For each suspected emission, the EUT was arranged to its worst case and then the antenna was tuned to heights from 1 meter to 4 meters and the rotatable table was turned from 0 degrees to 360 degrees to find the maximum reading.
- e. The test-receiver system was set to Peak Detect Function and Specified Bandwidth with Maximum Hold Mode.
- f. If the emission level of the EUT in peak mode was 10dB lower than the limit specified, then testing could be stopped and the peak values of the EUT would be reported. Otherwise the emissions that did not have 10dB margin would be re-tested one by one using peak, quasi-peak or average method as specified and then reported in a data sheet.

NOTE:

1. The resolution bandwidth and video bandwidth of test receiver/spectrum analyzer is 120kHz for Peak detection (PK) and Quasi-peak detection (QP) at frequency below 1GHz.
2. The resolution bandwidth of test receiver/spectrum analyzer is 1MHz and video bandwidth is 3MHz for Peak detection at frequency above 1GHz.
3. The resolution bandwidth of test receiver/spectrum analyzer is 1MHz and the video bandwidth is 10Hz for Average detection (AV) at frequency above 1GHz.
4. All modes of operation were investigated and the worst-case emissions are reported.

4.1.5 DEVIATION FROM TEST STANDARD

No deviation.



4.1.6 TEST SETUP

<Frequency Range below 1GHz>

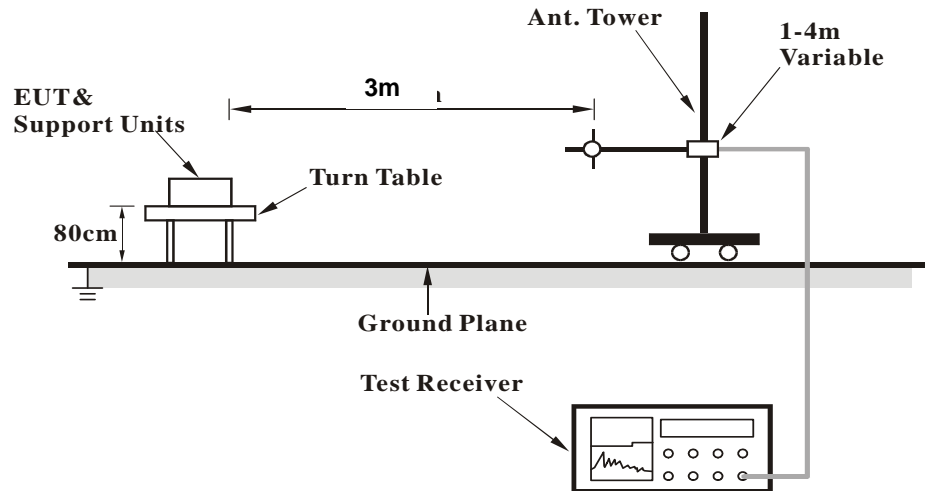

<Frequency Range above 1GHz>

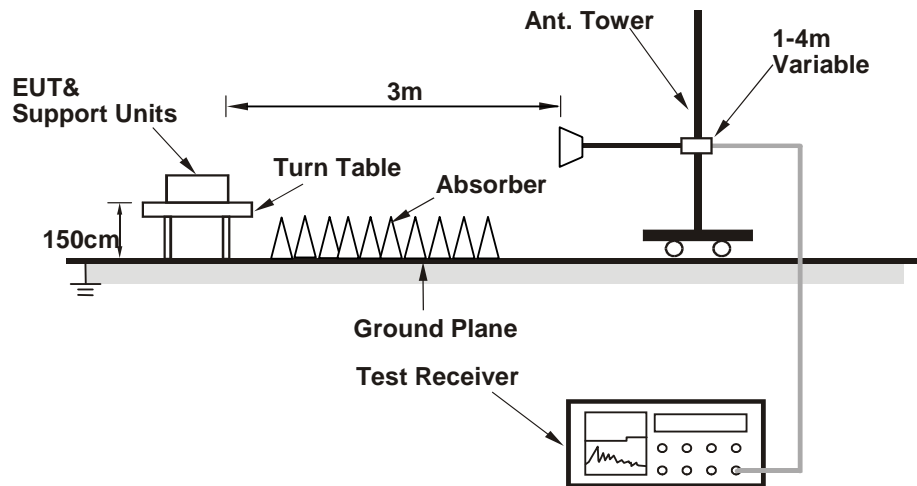

For the actual test configuration, please refer to the attached file (Test Setup Photo).



4.1.7 EUT OPERATING CONDITION

- a. Set the EUT under full load condition and placed them on a testing table.
- b. Set the transmitter part of EUT under transmission condition continuously at specific channel frequency.
- c. The necessary accessories enable the EUT in full functions.



4.1.8 TEST RESULTS

BELOW 1GHz WORST-CASE DATA:

9 KHz – 30 MHz data: the amplitude of spurious emissions attenuated more than 20 dB below the permissible value is not required in the report.

30 MHz – 1GHz data:

802.11ac 80MHz

CHANNEL	TX Channel 42	DETECTOR FUNCTION	Quasi-Peak (QP)
FREQUENCY RANGE	30MHz ~ 1GHz		

ANTENNA POLARITY & TEST DISTANCE: HORIZONTAL AT 3 M										
FREQ. (MHz)	EMISSION LEVEL (dBuV/m)	READ LEVEL (dBuV)	LIMIT (dBuV/m)	MARGIN (dB)	ANTENNA FACTOR (dB /m)	CABLE LOSS (dB)	PREAMP FACTOR (dB)	ANTENNA HEIGHT (cm)	TABLE ANGLE (Degree)	REMARK
31.94	18.07	39.03	40.00	-21.93	15.76	0.82	37.54	100	66	QP
86.26	27.96	56.82	40.00	-12.04	6.79	1.43	37.08	100	35	QP
183.26	31.10	55.76	43.50	-12.40	9.93	2.08	36.67	100	80	QP
275.41	30.84	52.06	46.00	-15.16	12.70	2.59	36.51	100	114	QP
331.67	23.90	43.28	46.00	-22.10	14.33	2.86	36.57	100	150	QP
422.85	23.56	39.64	46.00	-22.44	17.47	3.22	36.77	100	246	QP

REMARKS:

1. Emission level (dBuV/m) = Raw Value (dBuV) + Correction Factor (dB/m).
2. Correction Factor (dB/m) = Antenna Factor (dB/m) + Cable Factor (dB).
3. The other emission levels were very low against the limit.
4. Margin value = Emission level – Limit value.

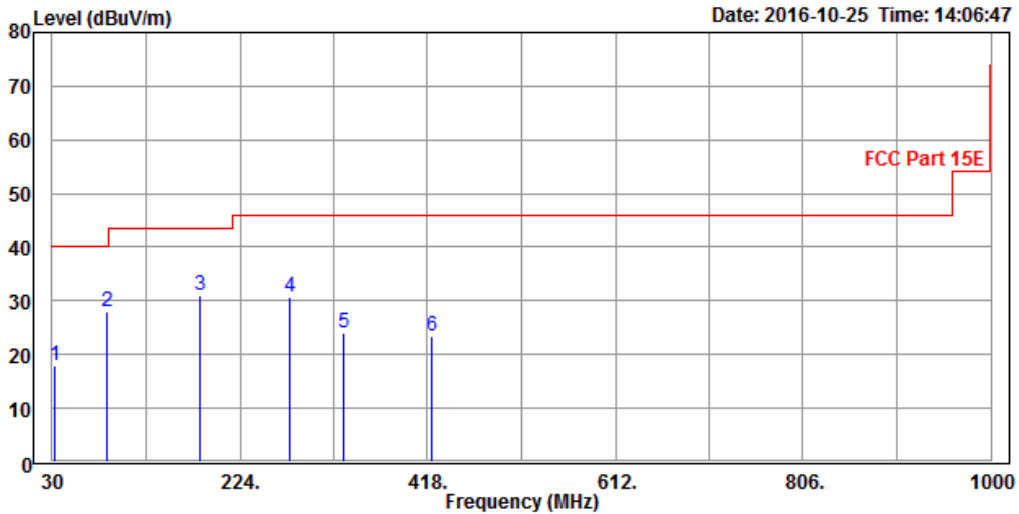



CHANNEL	Channel 42	DETECTOR FUNCTION	Quasi-Peak (QP)
FREQUENCY RANGE	30MHz ~ 1GHz		

ANTENNA POLARITY & TEST DISTANCE: VERTICAL AT 3 M										
FREQ. (MHz)	EMISSION LEVEL (dBuV/m)	READ LEVEL (dBuV)	LIMIT (dBuV/m)	MARGIN (dB)	ANTENNA FACTOR (dB /m)	CABLE LOSS (dB)	PREAMP FACTOR (dB)	ANTENNA HEIGHT (cm)	TABLE ANGLE (Degree)	REMARK
30.97	28.99	49.31	40.00	-11.01	16.43	0.80	37.55	100	15	QP
86.26	32.45	61.31	40.00	-7.55	6.79	1.43	37.08	100	32	QP
184.23	27.34	51.98	43.50	-16.16	9.94	2.08	36.66	100	72	QP
279.29	23.46	44.61	46.00	-22.54	12.75	2.61	36.51	100	128	QP
331.67	20.78	40.16	46.00	-25.22	14.33	2.86	36.57	100	192	QP
372.41	21.81	39.40	46.00	-24.19	16.04	3.03	36.66	100	240	QP

REMARKS:

1. Emission level (dBuV/m) = Raw Value (dBuV) + Correction Factor (dB/m).
2. Correction Factor (dB/m) = Antenna Factor (dB/m) + Cable Factor (dB).
3. The other emission levels were very low against the limit.
4. Margin value = Emission level – Limit value.

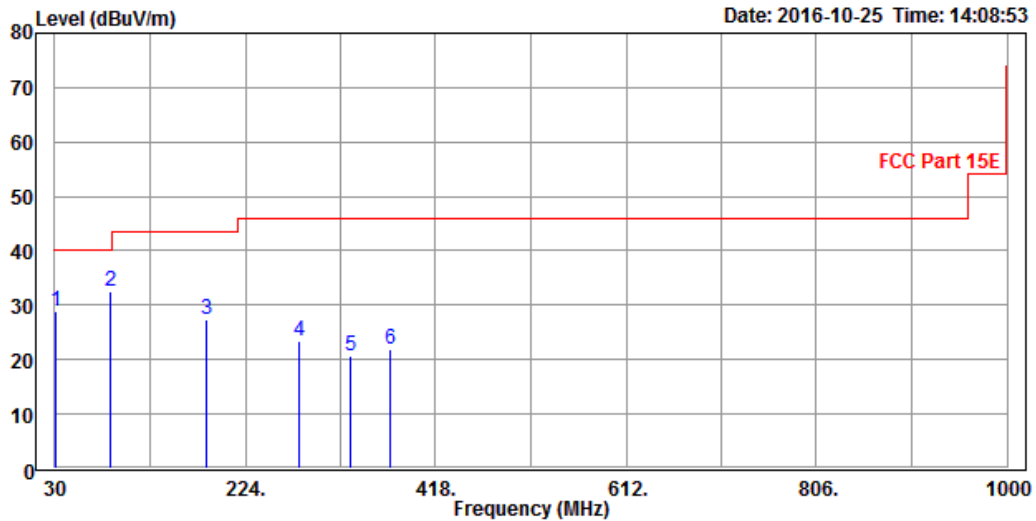



ABOVE 1GHz WORST-CASE DATA: Band 1

802.11a

CHANNEL	TX Channel 36	DETECTOR FUNCTION	Peak (PK)
FREQUENCY RANGE	1GHz ~ 40GHz		Average (AV)

ANTENNA POLARITY & TEST DISTANCE: HORIZONTAL AT 3 M										
FREQ. (MHz)	EMISSION LEVEL (dBuV/m)	READ LEVEL (dBuV)	LIMIT (dBuV/m)	MARGIN (dB)	ANTENNA FACTOR (dB /m)	CABLE LOSS (dB)	PREAMP FACTOR (dB)	ANTENNA HEIGHT (cm)	TABLE ANGLE (Degree)	REMARK
5127	43.40	44.32	54.00	-10.60	34.45	13.64	49.01	100	180	Average
5127	52.89	53.81	74.00	-21.11	34.45	13.64	49.01	100	180	Peak
5180	91.67	92.38			34.52	13.79	49.02	100	180	Average
5180	102.94	103.65			34.52	13.79	49.02	100	180	Peak
5350	41.82	41.90	54.00	-12.18	34.72	14.28	49.08	100	180	Average
5350	52.32	52.40	74.00	-21.68	34.72	14.28	49.08	100	180	Peak
#10360	65.53	56.84	68.30	-2.77	38.56	17.99	47.86	100	250	Peak

ANTENNA POLARITY & TEST DISTANCE: VERTICAL AT 3 M										
FREQ. (MHz)	EMISSION LEVEL (dBuV/m)	READ LEVEL (dBuV)	LIMIT (dBuV/m)	MARGIN (dB)	ANTENNA FACTOR (dB /m)	CABLE LOSS (dB)	PREAMP FACTOR (dB)	ANTENNA HEIGHT (cm)	TABLE ANGLE (Degree)	REMARK
5127	43.41	44.33	54.00	-10.59	34.45	13.64	49.01	170	80	Average
5127	53.25	54.17	74.00	-20.75	34.45	13.64	49.01	170	80	Peak
5180	94.70	95.41			34.52	13.79	49.02	170	80	Average
5180	103.52	104.23			34.52	13.79	49.02	170	80	Peak
5350	41.74	41.82	54.00	-12.26	34.72	14.28	49.08	170	80	Average
5350	52.11	52.19	74.00	-21.89	34.72	14.28	49.08	170	80	Peak
#10360	64.32	55.63	68.30	-3.98	38.56	17.99	47.86	150	60	Peak

REMARKS:

1. Emission Level = Read Level+ Antenna Factor + Cable Loss- Preamp Factor
Margin value = Emission level – Limit value.
2. 5180MHz: Fundamental frequency.
3. #: Out of restricted band.



CHANNEL	TX Channel 44	DETECTOR FUNCTION	Peak (PK)
FREQUENCY RANGE	1GHz ~ 40GHz		Average (AV)

ANTENNA POLARITY & TEST DISTANCE: HORIZONTAL AT 3 M

FREQ. (MHz)	EMISSION LEVEL (dBuV/m)	READ LEVEL (dBuV)	LIMIT (dBuV/m)	MARGIN (dB)	ANTENNA FACTOR (dB /m)	CABLE LOSS (dB)	PREAMP FACTOR (dB)	ANTENNA HEIGHT (cm)	TABLE ANGLE (Degree)	REMARK
5150	41.51	42.33	54.00	-12.49	34.48	13.71	49.01	140	180	Average
5150	52.51	53.33	74.00	-21.49	34.48	13.71	49.01	140	180	Peak
5220	93.05	93.62			34.56	13.91	49.04	140	180	Average
5220	102.09	102.66			34.56	13.91	49.04	140	180	Peak
5350	41.82	41.90	54.00	-12.18	34.72	14.28	49.08	140	180	Average
5350	52.49	52.57	74.00	-21.51	34.72	14.28	49.08	140	180	Peak
#10440	65.21	56.38	68.30	-3.09	38.64	18.07	47.88	100	250	Peak

ANTENNA POLARITY & TEST DISTANCE: VERTICAL AT 3 M

FREQ. (MHz)	EMISSION LEVEL (dBuV/m)	READ LEVEL (dBuV)	LIMIT (dBuV/m)	MARGIN (dB)	ANTENNA FACTOR (dB /m)	CABLE LOSS (dB)	PREAMP FACTOR (dB)	ANTENNA HEIGHT (cm)	TABLE ANGLE (Degree)	REMARK
5150	41.35	42.17	54.00	-12.65	34.48	13.71	49.01	170	80	Average
5150	51.67	52.49	74.00	-22.33	34.48	13.71	49.01	170	80	Peak
5220	95.03	95.60			34.56	13.91	49.04	170	80	Average
5220	104.49	105.06			34.56	13.91	49.04	170	80	Peak
5350	41.59	41.67	54.00	-12.41	34.72	14.28	49.08	170	80	Average
5350	52.13	52.21	74.00	-21.87	34.72	14.28	49.08	170	80	Peak
#10440	63.41	54.58	68.30	-4.89	38.64	18.07	47.88	120	60	Peak

REMARKS:

1. Emission Level = Read Level+ Antenna Factor + Cable Loss- Preamp Factor
Margin value = Emission level – Limit value.
2. 5220MHz: Fundamental frequency.
3. #: Out of restricted band.



CHANNEL	TX Channel 48	DETECTOR FUNCTION	Peak (PK)
FREQUENCY RANGE	1GHz ~ 40GHz		Average (AV)

ANTENNA POLARITY & TEST DISTANCE: HORIZONTAL AT 3 M										
FREQ. (MHz)	EMISSION LEVEL (dBuV/m)	READ LEVEL (dBuV)	LIMIT (dBuV/m)	MARGIN (dB)	ANTENNA FACTOR (dB /m)	CABLE LOSS (dB)	PREAMP FACTOR (dB)	ANTENNA HEIGHT (cm)	TABLE ANGLE (Degree)	REMARK
5150	41.58	42.40	54.00	-12.42	34.48	13.71	49.01	140	182	Average
5150	52.39	53.21	74.00	-21.61	34.48	13.71	49.01	140	182	Peak
5240	92.86	93.34			34.59	13.97	49.04	140	182	Average
5240	102.69	103.17			34.59	13.97	49.04	140	182	Peak
5350	41.81	41.89	54.00	-12.19	34.72	14.28	49.08	140	182	Average
5350	52.85	52.93	74.00	-21.15	34.72	14.28	49.08	140	182	Peak
#10480	65.44	56.55	68.30	-2.86	38.68	18.10	47.89	100	252	Peak

ANTENNA POLARITY & TEST DISTANCE: VERTICAL AT 3 M										
FREQ. (MHz)	EMISSION LEVEL (dBuV/m)	READ LEVEL (dBuV)	LIMIT (dBuV/m)	MARGIN (dB)	ANTENNA FACTOR (dB /m)	CABLE LOSS (dB)	PREAMP FACTOR (dB)	ANTENNA HEIGHT (cm)	TABLE ANGLE (Degree)	REMARK
5150	41.49	42.31	54.00	-12.51	34.48	13.71	49.01	172	80	Average
5150	52.44	53.26	74.00	-21.56	34.48	13.71	49.01	172	80	Peak
5240	94.29	94.77			34.59	13.97	49.04	172	80	Average
5240	104.79	105.27			34.59	13.97	49.04	172	80	Peak
5350	41.64	41.72	54.00	-12.36	34.72	14.28	49.08	172	80	Average
5350	51.71	51.79	74.00	-22.29	34.72	14.28	49.08	172	80	Peak
#10480	64.20	55.31	68.30	-4.10	38.68	18.10	47.89	115	40	Peak

REMARKS:

1. Emission Level = Read Level+ Antenna Factor + Cable Loss- Preamp Factor
Margin value = Emission level – Limit value.
2. 5240MHz: Fundamental frequency.
3. #: Out of restricted band.



802.11n (20MHz)

CHANNEL	TX Channel 36	DETECTOR FUNCTION	Peak (PK)
FREQUENCY RANGE	1GHz ~ 40GHz		Average (AV)

ANTENNA POLARITY & TEST DISTANCE: HORIZONTAL AT 3 M										
FREQ. (MHz)	EMISSION LEVEL (dBuV/m)	READ LEVEL (dBuV)	LIMIT (dBuV/m)	MARGIN (dB)	ANTENNA FACTOR (dB /m)	CABLE LOSS (dB)	PREAMP FACTOR (dB)	ANTENNA HEIGHT (cm)	TABLE ANGLE (Degree)	REMARK
5128	43.76	44.67	54.00	-10.24	34.45	13.65	49.01	150	180	Average
5128	52.73	53.64	74.00	-21.27	34.45	13.65	49.01	150	180	Peak
5180	92.41	93.12			34.52	13.79	49.02	150	180	Average
5180	102.27	102.98			34.52	13.79	49.02	150	180	Peak
5350	41.86	41.94	54.00	-12.14	34.72	14.28	49.08	150	180	Average
5350	51.81	51.89	74.00	-22.19	34.72	14.28	49.08	150	180	Peak
#10360	64.66	55.97	68.30	-3.64	38.56	17.99	47.86	100	250	Peak

ANTENNA POLARITY & TEST DISTANCE: VERTICAL AT 3 M										
FREQ. (MHz)	EMISSION LEVEL (dBuV/m)	READ LEVEL (dBuV)	LIMIT (dBuV/m)	MARGIN (dB)	ANTENNA FACTOR (dB /m)	CABLE LOSS (dB)	PREAMP FACTOR (dB)	ANTENNA HEIGHT (cm)	TABLE ANGLE (Degree)	REMARK
5128	43.27	44.18	54.00	-10.73	34.45	13.65	49.01	170	100	Average
5128	52.97	53.88	74.00	-21.03	34.45	13.65	49.01	170	100	Peak
5180	94.38	95.09			34.52	13.79	49.02	170	100	Average
5180	103.74	104.45			34.52	13.79	49.02	170	100	Peak
5350	41.84	41.92	54.00	-12.16	34.72	14.28	49.08	170	100	Average
5350	51.50	51.58	74.00	-22.50	34.72	14.28	49.08	170	100	Peak
#10360	63.79	55.10	68.30	-4.51	38.56	17.99	47.86	150	60	Peak

REMARKS:

1. Emission Level = Read Level+ Antenna Factor + Cable Loss- Preamp Factor
Margin value = Emission level – Limit value.
2. 5180MHz: Fundamental frequency.
3. #: Out of restricted band.



CHANNEL	TX Channel 44	DETECTOR FUNCTION	Peak (PK)
FREQUENCY RANGE	1GHz ~ 40GHz		Average (AV)

ANTENNA POLARITY & TEST DISTANCE: HORIZONTAL AT 3 M

FREQ. (MHz)	EMISSION LEVEL (dBuV/m)	READ LEVEL (dBuV)	LIMIT (dBuV/m)	MARGIN (dB)	ANTENNA FACTOR (dB /m)	CABLE LOSS (dB)	PREAMP FACTOR (dB)	ANTENNA HEIGHT (cm)	TABLE ANGLE (Degree)	REMARK
5150	41.33	42.15	54.00	-12.67	34.48	13.71	49.01	160	180	Average
5150	52.92	53.74	74.00	-21.08	34.48	13.71	49.01	160	180	Peak
5220	92.69	93.26			34.56	13.91	49.04	160	180	Average
5220	101.62	102.19			34.56	13.91	49.04	160	180	Peak
5350	41.86	41.94	54.00	-12.14	34.72	14.28	49.08	160	180	Average
5350	52.17	52.25	74.00	-21.83	34.72	14.28	49.08	160	180	Peak
#10440	65.23	56.40	68.30	-3.07	38.64	18.07	47.88	120	250	Peak

ANTENNA POLARITY & TEST DISTANCE: VERTICAL AT 3 M

FREQ. (MHz)	EMISSION LEVEL (dBuV/m)	READ LEVEL (dBuV)	LIMIT (dBuV/m)	MARGIN (dB)	ANTENNA FACTOR (dB /m)	CABLE LOSS (dB)	PREAMP FACTOR (dB)	ANTENNA HEIGHT (cm)	TABLE ANGLE (Degree)	REMARK
5150	41.61	42.43	54.00	-12.39	34.48	13.71	49.01	170	110	Average
5150	53.33	54.15	74.00	-20.67	34.48	13.71	49.01	170	110	Peak
5220	94.46	95.03			34.56	13.91	49.04	170	110	Average
5220	103.89	104.46			34.56	13.91	49.04	170	110	Peak
5350	41.78	41.86	54.00	-12.22	34.72	14.28	49.08	170	110	Average
5350	51.98	52.06	74.00	-22.02	34.72	14.28	49.08	170	110	Peak
#10440	63.26	54.43	68.30	-5.04	38.64	18.07	47.88	150	65	Peak

REMARKS:

1. Emission Level = Read Level+ Antenna Factor + Cable Loss- Preamp Factor
Margin value = Emission level – Limit value.
2. 5220MHz: Fundamental frequency.
3. #: Out of restricted band.



CHANNEL	TX Channel 48	DETECTOR FUNCTION	Peak (PK)
FREQUENCY RANGE	1GHz ~ 40GHz		Average (AV)

ANTENNA POLARITY & TEST DISTANCE: HORIZONTAL AT 3 M										
FREQ. (MHz)	EMISSION LEVEL (dBuV/m)	READ LEVEL (dBuV)	LIMIT (dBuV/m)	MARGIN (dB)	ANTENNA FACTOR (dB /m)	CABLE LOSS (dB)	PREAMP FACTOR (dB)	ANTENNA HEIGHT (cm)	TABLE ANGLE (Degree)	REMARK
5150	41.63	42.45	54.00	-12.37	34.48	13.71	49.01	160	175	Average
5150	53.41	54.23	74.00	-20.59	34.48	13.71	49.01	160	175	Peak
5240	92.69	93.17			34.59	13.97	49.04	160	175	Average
5240	102.37	102.85			34.59	13.97	49.04	160	175	Peak
5350	41.80	41.88	54.00	-12.20	34.72	14.28	49.08	160	175	Average
5350	51.92	52.00	74.00	-22.08	34.72	14.28	49.08	160	175	Peak
#10480	64.76	55.87	68.30	-3.54	38.68	18.10	47.89	110	250	Peak
ANTENNA POLARITY & TEST DISTANCE: VERTICAL AT 3 M										
FREQ. (MHz)	EMISSION LEVEL (dBuV/m)	READ LEVEL (dBuV)	LIMIT (dBuV/m)	MARGIN (dB)	ANTENNA FACTOR (dB /m)	CABLE LOSS (dB)	PREAMP FACTOR (dB)	ANTENNA HEIGHT (cm)	TABLE ANGLE (Degree)	REMARK
5150	41.54	42.36	54.00	-12.46	34.48	13.71	49.01	170	85	Average
5150	51.71	52.53	74.00	-22.29	34.48	13.71	49.01	170	85	Peak
5240	94.37	94.85			34.59	13.97	49.04	170	85	Average
5240	103.75	104.23			34.59	13.97	49.04	170	85	Peak
5350	41.71	41.79	54.00	-12.29	34.72	14.28	49.08	170	85	Average
5350	52.16	52.24	74.00	-21.84	34.72	14.28	49.08	170	85	Peak
#10480	64.44	55.55	68.30	-3.86	38.68	18.10	47.89	100	58	Peak

REMARKS:

1. Emission Level = Read Level+ Antenna Factor + Cable Loss- Preamp Factor
Margin value = Emission level – Limit value.
2. 5240MHz: Fundamental frequency.
3. #: Out of restricted band.



802.11n (40MHz)

CHANNEL	TX Channel 38	DETECTOR FUNCTION	Peak (PK)
FREQUENCY RANGE	1GHz ~ 40GHz		Average (AV)

ANTENNA POLARITY & TEST DISTANCE: HORIZONTAL AT 3 M										
FREQ. (MHz)	EMISSION LEVEL (dBuV/m)	READ LEVEL (dBuV)	LIMIT (dBuV/m)	MARGIN (dB)	ANTENNA FACTOR (dB /m)	CABLE LOSS (dB)	PREAMP FACTOR (dB)	ANTENNA HEIGHT (cm)	TABLE ANGLE (Degree)	REMARK
5150	42.59	43.41	54.00	-11.41	34.48	13.71	49.01	150	250	Average
5150	53.14	53.96	74.00	-20.86	34.48	13.71	49.01	150	250	Peak
5190	89.36	90.04			34.53	13.82	49.03	150	250	Average
5190	99.49	100.17			34.53	13.82	49.03	150	250	Peak
5350	41.82	41.90			34.72	14.28	49.08	150	250	Average
5350	52.29	52.37	74.00	-21.71	34.72	14.28	49.08	150	250	Peak
#10380	63.10	54.38	68.30	-5.20	38.58	18.01	47.87	100	249	Peak
ANTENNA POLARITY & TEST DISTANCE: VERTICAL AT 3 M										
FREQ. (MHz)	EMISSION LEVEL (dBuV/m)	READ LEVEL (dBuV)	LIMIT (dBuV/m)	MARGIN (dB)	ANTENNA FACTOR (dB /m)	CABLE LOSS (dB)	PREAMP FACTOR (dB)	ANTENNA HEIGHT (cm)	TABLE ANGLE (Degree)	REMARK
5150	42.42	43.24	54.00	-11.58	34.48	13.71	49.01	170	100	Average
5150	53.92	54.74	74.00	-20.08	34.48	13.71	49.01	170	100	Peak
5190	89.66	90.34			34.53	13.82	49.03	170	100	Average
5190	101.16	101.84			34.53	13.82	49.03	170	100	Peak
5350	41.82	41.90	54.00	-12.18	34.72	14.28	49.08	170	100	Average
5350	52.21	52.29	74.00	-21.79	34.72	14.28	49.08	170	100	Peak
#10380	60.83	52.11	68.30	-7.47	38.58	18.01	47.87	150	60	Peak

REMARKS:

1. Emission Level = Read Level+ Antenna Factor + Cable Loss- Preamp Factor
Margin value = Emission level – Limit value.
2. 5190MHz: Fundamental frequency.
3. #: Out of restricted band.



CHANNEL	TX Channel 46	DETECTOR FUNCTION	Peak (PK)
FREQUENCY RANGE	1GHz ~ 40GHz		Average (AV)

ANTENNA POLARITY & TEST DISTANCE: HORIZONTAL AT 3 M										
FREQ. (MHz)	EMISSION LEVEL (dBuV/m)	READ LEVEL (dBuV)	LIMIT (dBuV/m)	MARGIN (dB)	ANTENNA FACTOR (dB /m)	CABLE LOSS (dB)	PREAMP FACTOR (dB)	ANTENNA HEIGHT (cm)	TABLE ANGLE (Degree)	REMARK
5127	42.11	43.03	54.00	-11.89	34.45	13.64	49.01	170	180	Average
5127	52.55	53.47	74.00	-21.45	34.45	13.64	49.01	170	180	Peak
5230	89.49	90.01			34.58	13.94	49.04	150	248	Average
5230	100.09	100.61			34.58	13.94	49.04	150	248	Peak
5350	41.88	41.96	54.00	-12.12	34.72	14.28	49.08	170	180	Average
5350	52.51	52.59	74.00	-21.49	34.72	14.28	49.08	170	180	Peak
#10460	62.88	54.02	68.30	-5.42	38.66	18.08	47.88	100	249	Peak

ANTENNA POLARITY & TEST DISTANCE: VERTICAL AT 3 M										
FREQ. (MHz)	EMISSION LEVEL (dBuV/m)	READ LEVEL (dBuV)	LIMIT (dBuV/m)	MARGIN (dB)	ANTENNA FACTOR (dB /m)	CABLE LOSS (dB)	PREAMP FACTOR (dB)	ANTENNA HEIGHT (cm)	TABLE ANGLE (Degree)	REMARK
5127	41.40	42.32	54.00	-12.60	34.45	13.64	49.01	170	90	Average
5127	52.25	53.17	74.00	-21.75	34.45	13.64	49.01	170	90	Peak
5230	90.01	90.53			34.58	13.94	49.04	170	90	Average
5230	99.90	100.42			34.58	13.94	49.04	170	90	Peak
5350	41.78	41.86	54.00	-12.22	34.72	14.28	49.08	170	90	Average
5350	52.33	52.41	74.00	-21.67	34.72	14.28	49.08	170	90	Peak
#10460	61.09	52.23	68.30	-7.21	38.66	18.08	47.88	160	65	Peak

REMARKS:

1. Emission Level = Read Level+ Antenna Factor + Cable Loss- Preamp Factor
Margin value = Emission level – Limit value.
2. 5230MHz: Fundamental frequency.
3. #: Out of restricted band.



802.11ac (80MHz)

CHANNEL	TX Channel 42	DETECTOR FUNCTION	Peak (PK)
FREQUENCY RANGE	1GHz ~ 40GHz		Average (AV)

ANTENNA POLARITY & TEST DISTANCE: HORIZONTAL AT 3 M										
FREQ. (MHz)	EMISSION LEVEL (dBuV/m)	READ LEVEL (dBuV)	LIMIT (dBuV/m)	MARGIN (dB)	ANTENNA FACTOR (dB /m)	CABLE LOSS (dB)	PREAMP FACTOR (dB)	ANTENNA HEIGHT (cm)	TABLE ANGLE (Degree)	REMARK
5150	43.87	44.69	54.00	-10.13	34.48	13.71	49.01	160	240	Average
5150	55.82	56.64	74.00	-18.18	34.48	13.71	49.01	160	240	Peak
5210	85.57	86.17			34.55	13.88	49.03	160	240	Average
5210	99.39	99.99			34.55	13.88	49.03	160	240	Peak
5350	41.88	41.96	54.00	-12.12	34.72	14.28	49.08	160	240	Average
5350	51.71	51.79	74.00	-22.29	34.72	14.28	49.08	160	240	Peak

ANTENNA POLARITY & TEST DISTANCE: VERTICAL AT 3 M										
FREQ. (MHz)	EMISSION LEVEL (dBuV/m)	READ LEVEL (dBuV)	LIMIT (dBuV/m)	MARGIN (dB)	ANTENNA FACTOR (dB /m)	CABLE LOSS (dB)	PREAMP FACTOR (dB)	ANTENNA HEIGHT (cm)	TABLE ANGLE (Degree)	REMARK
5147	53.10	53.93	54.00	-0.90	34.48	13.70	49.01	100	148	Average
5147	66.52	67.35	74.00	-7.48	34.48	13.70	49.01	100	148	Peak
5210	88.90	89.50			34.55	13.88	49.03	100	148	Average
5210	103.19	103.79			34.55	13.88	49.03	100	148	Peak
5350	41.53	41.61	54.00	-12.47	34.72	14.28	49.08	100	148	Average
5350	52.05	52.13	74.00	-21.95	34.72	14.28	49.08	100	148	Peak

REMARKS:

1. Emission Level = Read Level+ Antenna Factor + Cable Loss- Preamp Factor
Margin value = Emission level – Limit value.
2. 5210MHz: Fundamental frequency.



ABOVE 1GHz WORST-CASE DATA: Band 2
802.11a

CHANNEL	TX Channel 52	DETECTOR FUNCTION	Peak (PK)
FREQUENCY RANGE	1GHz ~ 40GHz		Average (AV)

ANTENNA POLARITY & TEST DISTANCE: HORIZONTAL AT 3 M

FREQ. (MHz)	EMISSION LEVEL (dBuV/m)	READ LEVEL (dBuV)	LIMIT (dBuV/m)	MARGIN (dB)	ANTENNA FACTOR (dB /m)	CABLE LOSS (dB)	PREAMP FACTOR (dB)	ANTENNA HEIGHT (cm)	TABLE ANGLE (Degree)	REMARK
5150	41.41	42.23	54.00	-12.59	34.48	13.71	49.01	140	250	Average
5150	52.19	53.01	74.00	-21.81	34.48	13.71	49.01	140	250	Peak
5260	94.43	94.85			34.61	14.02	49.05	140	250	Average
5260	103.60	104.02			34.61	14.02	49.05	140	250	Peak
5355	41.75	41.80	54.00	-12.25	34.73	14.30	49.08	140	250	Average
5355	52.58	52.63	74.00	-21.42	34.73	14.30	49.08	140	250	Peak
#10520	64.00	55.06	68.30	-4.30	38.71	18.13	47.90	100	250	Peak

ANTENNA POLARITY & TEST DISTANCE: VERTICAL AT 3 M

FREQ. (MHz)	EMISSION LEVEL (dBuV/m)	READ LEVEL (dBuV)	LIMIT (dBuV/m)	MARGIN (dB)	ANTENNA FACTOR (dB /m)	CABLE LOSS (dB)	PREAMP FACTOR (dB)	ANTENNA HEIGHT (cm)	TABLE ANGLE (Degree)	REMARK
5150	41.24	42.06	54.00	-12.76	34.48	13.71	49.01	175	100	Average
5150	51.99	52.81	74.00	-22.01	34.48	13.71	49.01	175	100	Peak
5260	94.96	95.38			34.61	14.02	49.05	175	100	Average
5260	103.98	104.40			34.61	14.02	49.05	175	100	Peak
5350	41.57	41.65	54.00	-12.43	34.72	14.28	49.08	175	100	Average
5350	54.05	54.13	74.00	-19.95	34.72	14.28	49.08	175	100	Peak
#10520	65.14	56.20	68.30	-3.16	38.71	18.13	47.90	100	60	Peak

REMARKS:

1. Emission Level = Read Level+ Antenna Factor + Cable Loss- Preamp Factor
Margin value = Emission level – Limit value.
2. 5260MHz: Fundamental frequency.
3. #: Out of restricted band.



CHANNEL	TX Channel 60	DETECTOR FUNCTION	Peak (PK)
FREQUENCY RANGE	1GHz ~ 40GHz		Average (AV)

ANTENNA POLARITY & TEST DISTANCE: HORIZONTAL AT 3 M										
FREQ. (MHz)	EMISSION LEVEL (dBuV/m)	READ LEVEL (dBuV)	LIMIT (dBuV/m)	MARGIN (dB)	ANTENNA FACTOR (dB /m)	CABLE LOSS (dB)	PREAMP FACTOR (dB)	ANTENNA HEIGHT (cm)	TABLE ANGLE (Degree)	REMARK
5150	41.52	42.34	54.00	-12.48	34.48	13.71	49.01	150	250	Average
5150	51.56	52.38	74.00	-22.44	34.48	13.71	49.01	150	250	Peak
5300	94.82	95.08			34.66	14.14	49.06	150	250	Average
5300	104.40	104.66			34.66	14.14	49.06	150	250	Peak
5352	44.89	44.96	54.00	-9.11	34.72	14.29	49.08	150	250	Average
5352	53.19	53.26	74.00	-20.81	34.72	14.29	49.08	150	250	Peak
#10600	63.09	54.09	68.30	-5.21	38.74	18.18	47.92	100	250	Peak
ANTENNA POLARITY & TEST DISTANCE: VERTICAL AT 3 M										
FREQ. (MHz)	EMISSION LEVEL (dBuV/m)	READ LEVEL (dBuV)	LIMIT (dBuV/m)	MARGIN (dB)	ANTENNA FACTOR (dB /m)	CABLE LOSS (dB)	PREAMP FACTOR (dB)	ANTENNA HEIGHT (cm)	TABLE ANGLE (Degree)	REMARK
5150	41.66	42.48	54.00	-12.34	34.48	13.71	49.01	180	100	Average
5150	52.21	53.03	74.00	-21.79	34.48	13.71	49.01	180	100	Peak
5300	94.78	95.04			34.66	14.14	49.06	180	100	Average
5300	104.71	104.97			34.66	14.14	49.06	180	100	Peak
5352	45.28	45.35	54.00	-8.72	34.72	14.29	49.08	180	100	Average
5352	54.50	54.57	74.00	-19.50	34.72	14.29	49.08	180	100	Peak
#10600	64.22	55.22	68.30	-4.08	38.74	18.18	47.92	120	60	Peak

REMARKS:

1. Emission Level = Read Level+ Antenna Factor + Cable Loss- Preamp Factor
Margin value = Emission level – Limit value.
2. 5300MHz: Fundamental frequency.
3. #: Out of restricted band.



CHANNEL	TX Channel 64	DETECTOR FUNCTION	Peak (PK)
FREQUENCY RANGE	1GHz ~ 40GHz		Average (AV)

ANTENNA POLARITY & TEST DISTANCE: HORIZONTAL AT 3 M										
FREQ. (MHz)	EMISSION LEVEL (dBuV/m)	READ LEVEL (dBuV)	LIMIT (dBuV/m)	MARGIN (dB)	ANTENNA FACTOR (dB /m)	CABLE LOSS (dB)	PREAMP FACTOR (dB)	ANTENNA HEIGHT (cm)	TABLE ANGLE (Degree)	REMARK
5150	41.65	42.47	54.00	-12.35	34.48	13.71	49.01	140	252	Average
5150	52.57	53.39	74.00	-21.43	34.48	13.71	49.01	140	252	Peak
5320	94.36	94.55			34.68	14.20	49.07	140	252	Average
5320	102.87	103.06			34.68	14.20	49.07	140	252	Peak
5372	44.36	44.35	54.00	-9.64	34.75	14.34	49.08	140	252	Average
5372	53.28	53.27	74.00	-20.72	34.75	14.34	49.08	140	252	Peak
#10640	61.64	52.60		-6.66	38.76	18.21	47.93	100	248	Peak
ANTENNA POLARITY & TEST DISTANCE: VERTICAL AT 3 M										
FREQ. (MHz)	EMISSION LEVEL (dBuV/m)	READ LEVEL (dBuV)	LIMIT (dBuV/m)	MARGIN (dB)	ANTENNA FACTOR (dB /m)	CABLE LOSS (dB)	PREAMP FACTOR (dB)	ANTENNA HEIGHT (cm)	TABLE ANGLE (Degree)	REMARK
5150	41.55	42.37	54.00	-12.45	34.48	13.71	49.01	150	90	Average
5150	51.83	52.65	74.00	-22.17	34.48	13.71	49.01	150	90	Peak
5320	94.39	94.58			34.68	14.20	49.07	150	90	Average
5320	103.74	103.93			34.68	14.20	49.07	150	90	Peak
5372	44.57	44.56	54.00	-9.43	34.75	14.34	49.08	150	90	Average
5372	53.76	53.75	74.00	-20.24	34.75	14.34	49.08	150	90	Peak
#10640	61.38	52.34	68.30	-6.92	38.76	18.21	47.93	150	63	Peak

REMARKS:

- Emission Level = Read Level+ Antenna Factor + Cable Loss- Preamp Factor
Margin value = Emission level – Limit value.
- 5320MHz: Fundamental frequency.
- #: Out of restricted band.



802.11n (20MHz)

CHANNEL	TX Channel 52	DETECTOR FUNCTION	Peak (PK)
FREQUENCY RANGE	1GHz ~ 40GHz		Average (AV)

ANTENNA POLARITY & TEST DISTANCE: HORIZONTAL AT 3 M										
FREQ. (MHz)	EMISSION LEVEL (dBuV/m)	READ LEVEL (dBuV)	LIMIT (dBuV/m)	MARGIN (dB)	ANTENNA FACTOR (dB /m)	CABLE LOSS (dB)	PREAMP FACTOR (dB)	ANTENNA HEIGHT (cm)	TABLE ANGLE (Degree)	REMARK
5150	41.47	42.29	54.00	-12.53	34.48	13.71	49.01	140	250	Average
5150	53.02	53.84	74.00	-20.98	34.48	13.71	49.01	140	250	Peak
5260	94.37	94.79			34.61	14.02	49.05	140	250	Average
5260	104.12	104.54			34.61	14.02	49.05	140	250	Peak
5350	41.71	41.79	54.00	-12.29	34.72	14.28	49.08	140	250	Average
5350	52.55	52.63	74.00	-21.45	34.72	14.28	49.08	140	250	Peak
#10520	63.66	54.72	68.30	-4.64	38.71	18.13	47.90	100	250	Peak
ANTENNA POLARITY & TEST DISTANCE: VERTICAL AT 3 M										
FREQ. (MHz)	EMISSION LEVEL (dBuV/m)	READ LEVEL (dBuV)	LIMIT (dBuV/m)	MARGIN (dB)	ANTENNA FACTOR (dB /m)	CABLE LOSS (dB)	PREAMP FACTOR (dB)	ANTENNA HEIGHT (cm)	TABLE ANGLE (Degree)	REMARK
5150	41.50	42.32	54.00	-12.50	34.48	13.71	49.01	170	90	Average
5150	51.55	52.37	74.00	-22.45	34.48	13.71	49.01	170	90	Peak
5260	93.46	93.88			34.61	14.02	49.05	170	90	Average
5260	102.97	103.39			34.61	14.02	49.05	170	90	Peak
5350	41.74	41.82	54.00	-12.26	34.72	14.28	49.08	170	90	Average
5350	51.67	51.75	74.00	-22.33	34.72	14.28	49.08	170	90	Peak
#10520	64.86	55.92	68.30	-3.44	38.71	18.13	47.90	100	55	Peak

REMARKS:

1. Emission Level = Read Level+ Antenna Factor + Cable Loss- Preamp Factor
Margin value = Emission level – Limit value.
2. 5260MHz: Fundamental frequency.
3. #: Out of restricted band.



CHANNEL	TX Channel 60	DETECTOR FUNCTION	Peak (PK)
FREQUENCY RANGE	1GHz ~ 40GHz		Average (AV)

ANTENNA POLARITY & TEST DISTANCE: HORIZONTAL AT 3 M										
FREQ. (MHz)	EMISSION LEVEL (dBuV/m)	READ LEVEL (dBuV)	LIMIT (dBuV/m)	MARGIN (dB)	ANTENNA FACTOR (dB /m)	CABLE LOSS (dB)	PREAMP FACTOR (dB)	ANTENNA HEIGHT (cm)	TABLE ANGLE (Degree)	REMARK
5150	41.27	42.09	54.00	-12.73	34.48	13.71	49.01	139	250	Average
5150	51.73	52.55	74.00	-22.27	34.48	13.71	49.01	139	250	Peak
5300	94.69	94.95			34.66	14.14	49.06	139	250	Average
5300	103.69	103.95			34.66	14.14	49.06	139	250	Peak
5351	44.99	45.07	54.00	-9.01	34.72	14.28	49.08	139	250	Average
5351	53.82	53.90	74.00	-20.18	34.72	14.28	49.08	139	250	Peak
#10600	62.43	53.43	68.30	-5.87	38.74	18.18	47.92	100	249	Peak
ANTENNA POLARITY & TEST DISTANCE: VERTICAL AT 3 M										
FREQ. (MHz)	EMISSION LEVEL (dBuV/m)	READ LEVEL (dBuV)	LIMIT (dBuV/m)	MARGIN (dB)	ANTENNA FACTOR (dB /m)	CABLE LOSS (dB)	PREAMP FACTOR (dB)	ANTENNA HEIGHT (cm)	TABLE ANGLE (Degree)	REMARK
5150	41.47	42.29	54.00	-12.53	34.48	13.71	49.01	158	80	Average
5150	51.37	52.19	74.00	-22.63	34.48	13.71	49.01	158	80	Peak
5300	95.03	95.29			34.66	14.14	49.06	158	80	Average
5300	103.93	104.19			34.66	14.14	49.06	158	80	Peak
5352	45.24	45.31	54.00	-8.76	34.72	14.29	49.08	158	80	Average
5352	55.00	55.07	74.00	-19.00	34.72	14.29	49.08	158	80	Peak
#10600	63.61	54.61	68.30	-4.69	38.74	18.18	47.92	100	55	Peak

REMARKS:

1. Emission Level = Read Level+ Antenna Factor + Cable Loss- Preamp Factor
Margin value = Emission level – Limit value.
2. 5300MHz: Fundamental frequency.
3. #: Out of restricted band.



CHANNEL	TX Channel 64	DETECTOR FUNCTION	Peak (PK)
FREQUENCY RANGE	1GHz ~ 40GHz		Average (AV)

ANTENNA POLARITY & TEST DISTANCE: HORIZONTAL AT 3 M										
FREQ. (MHz)	EMISSION LEVEL (dBuV/m)	READ LEVEL (dBuV)	LIMIT (dBuV/m)	MARGIN (dB)	ANTENNA FACTOR (dB /m)	CABLE LOSS (dB)	PREAMP FACTOR (dB)	ANTENNA HEIGHT (cm)	TABLE ANGLE (Degree)	REMARK
5150	41.36	42.18	54.00	-12.64	34.48	13.71	49.01	150	250	Average
5150	51.68	52.50	74.00	-22.32	34.48	13.71	49.01	150	250	Peak
5320	94.17	94.36			34.68	14.20	49.07	150	250	Average
5320	103.19	103.38			34.68	14.20	49.07	150	250	Peak
5372	45.10	45.09	54.00	-8.90	34.75	14.34	49.08	150	250	Average
5372	53.81	53.80	74.00	-20.19	34.75	14.34	49.08	150	250	Peak
#10640	62.06	53.02	68.30	-6.24	38.76	18.21	47.93	100	260	Peak
ANTENNA POLARITY & TEST DISTANCE: VERTICAL AT 3 M										
FREQ. (MHz)	EMISSION LEVEL (dBuV/m)	READ LEVEL (dBuV)	LIMIT (dBuV/m)	MARGIN (dB)	ANTENNA FACTOR (dB /m)	CABLE LOSS (dB)	PREAMP FACTOR (dB)	ANTENNA HEIGHT (cm)	TABLE ANGLE (Degree)	REMARK
5150	41.52	42.34	54.00	-12.48	34.48	13.71	49.01	182	85	Average
5150	52.44	53.26	74.00	-21.56	34.48	13.71	49.01	182	85	Peak
5320	94.58	94.77			34.68	14.20	49.07	182	85	Average
5320	103.54	103.73			34.68	14.20	49.07	182	85	Peak
5372	44.32	44.31	54.00	-9.68	34.75	14.34	49.08	182	85	Average
5372	53.14	53.13	74.00	-20.86	34.75	14.34	49.08	182	85	Peak
#10640	62.54	53.50	68.30	-5.76	38.76	18.21	47.93	120	60	Peak

REMARKS:

1. Emission Level = Read Level+ Antenna Factor + Cable Loss- Preamp Factor
Margin value = Emission level – Limit value.
2. 5320MHz: Fundamental frequency.
3. #: Out of restricted band.



802.11n (40MHz)

CHANNEL	TX Channel 54	DETECTOR FUNCTION	Peak (PK)
FREQUENCY RANGE	1GHz ~ 40GHz		Average (AV)

ANTENNA POLARITY & TEST DISTANCE: HORIZONTAL AT 3 M										
FREQ. (MHz)	EMISSION LEVEL (dBuV/m)	READ LEVEL (dBuV)	LIMIT (dBuV/m)	MARGIN (dB)	ANTENNA FACTOR (dB /m)	CABLE LOSS (dB)	PREAMP FACTOR (dB)	ANTENNA HEIGHT (cm)	TABLE ANGLE (Degree)	REMARK
5150	41.21	42.03	54.00	-12.79	34.48	13.71	49.01	100	248	Average
5150	52.28	53.10	74.00	-21.72	34.48	13.71	49.01	100	248	Peak
5270	89.94	90.32			34.62	14.05	49.05	100	248	Average
5270	100.48	100.86			34.62	14.05	49.05	100	248	Peak
5372	42.14	42.13	54.00	-11.86	34.75	14.34	49.08	100	248	Average
5372	51.87	51.86	74.00	-22.13	34.75	14.34	49.08	100	248	Peak
#10540	61.26	52.30	68.30	-7.04	38.72	18.14	47.90	100	248	Peak
ANTENNA POLARITY & TEST DISTANCE: VERTICAL AT 3 M										
FREQ. (MHz)	EMISSION LEVEL (dBuV/m)	READ LEVEL (dBuV)	LIMIT (dBuV/m)	MARGIN (dB)	ANTENNA FACTOR (dB /m)	CABLE LOSS (dB)	PREAMP FACTOR (dB)	ANTENNA HEIGHT (cm)	TABLE ANGLE (Degree)	REMARK
5135	41.16	42.04	54.00	-12.84	34.46	13.67	49.01	100	100	Average
5135	52.08	52.96	74.00	-21.92	34.46	13.67	49.01	100	100	Peak
5270	89.16	89.54			34.62	14.05	49.05	100	100	Average
5270	99.82	100.20			34.62	14.05	49.05	100	100	Peak
5350	41.71	41.79	54.00	-12.29	34.72	14.28	49.08	100	100	Average
5350	52.26	52.34	74.00	-21.74	34.72	14.28	49.08	100	100	Peak
#10540	61.65	52.69	68.30	-6.65	38.72	18.14	47.90	150	63	Peak

REMARKS:

1. Emission Level = Read Level+ Antenna Factor + Cable Loss- Preamp Factor
Margin value = Emission level – Limit value.
2. 5270MHz: Fundamental frequency.
3. #: Out of restricted band.



CHANNEL	TX Channel 62	DETECTOR FUNCTION	Peak (PK)
FREQUENCY RANGE	1GHz ~ 40GHz		Average (AV)

ANTENNA POLARITY & TEST DISTANCE: HORIZONTAL AT 3 M										
FREQ. (MHz)	EMISSION LEVEL (dBuV/m)	READ LEVEL (dBuV)	LIMIT (dBuV/m)	MARGIN (dB)	ANTENNA FACTOR (dB /m)	CABLE LOSS (dB)	PREAMP FACTOR (dB)	ANTENNA HEIGHT (cm)	TABLE ANGLE (Degree)	REMARK
5150	41.20	42.02	54.00	-12.80	34.48	13.71	49.01	140	248	Average
5150	51.84	52.66	74.00	-22.16	34.48	13.71	49.01	140	248	Peak
5310	89.63	89.85			34.67	14.17	49.06	140	248	Average
5310	100.35	100.57			34.67	14.17	49.06	140	248	Peak
5350	42.78	42.86	54.00	-11.22	34.72	14.28	49.08	140	248	Average
5350	53.38	53.46	74.00	-20.62	34.72	14.28	49.08	140	248	Peak
#10620	62.38	53.36	68.30	-5.92	38.75	18.19	47.92	100	248	Peak
ANTENNA POLARITY & TEST DISTANCE: VERTICAL AT 3 M										
FREQ. (MHz)	EMISSION LEVEL (dBuV/m)	READ LEVEL (dBuV)	LIMIT (dBuV/m)	MARGIN (dB)	ANTENNA FACTOR (dB /m)	CABLE LOSS (dB)	PREAMP FACTOR (dB)	ANTENNA HEIGHT (cm)	TABLE ANGLE (Degree)	REMARK
5150	41.36	42.18	54.00	-12.64	34.48	13.71	49.01	180	90	Average
5150	51.90	52.72	74.00	-22.10	34.48	13.71	49.01	180	90	Peak
5310	89.99	90.21			34.67	14.17	49.06	180	90	Average
5310	100.93	101.15			34.67	14.17	49.06	180	90	Peak
5350	42.79	42.87	54.00	-11.21	34.72	14.28	49.08	180	90	Average
5350	53.40	53.48	74.00	-20.60	34.72	14.28	49.08	180	90	Peak
#10620	61.38	52.36	-68.30	-6.92	38.75	18.19	47.92	100	63	Peak

REMARKS:

1. Emission Level = Read Level+ Antenna Factor + Cable Loss- Preamp Factor
Margin value = Emission level – Limit value.
2. 5310MHz: Fundamental frequency.
3. #: Out of restricted band.



802.11ac (80MHz)

CHANNEL	TX Channel 58	DETECTOR FUNCTION	Peak (PK)
FREQUENCY RANGE	1GHz ~ 40GHz		Average (AV)

ANTENNA POLARITY & TEST DISTANCE: HORIZONTAL AT 3 M										
FREQ. (MHz)	EMISSION LEVEL (dBuV/m)	READ LEVEL (dBuV)	LIMIT (dBuV/m)	MARGIN (dB)	ANTENNA FACTOR (dB /m)	CABLE LOSS (dB)	PREAMP FACTOR (dB)	ANTENNA HEIGHT (cm)	TABLE ANGLE (Degree)	REMARK
5136	41.47	42.35	54.00	-12.53	34.46	13.67	49.01	130	180	Average
5136	53.20	54.08	74.00	-20.80	34.46	13.67	49.01	130	180	Peak
5290	84.79	85.09			34.65	14.11	49.06	130	180	Average
5290	97.54	97.84			34.65	14.11	49.06	130	180	Peak
5350	42.80	42.88	54.00	-11.20	34.72	14.28	49.08	130	180	Average
5350	55.72	55.80	74.00	-18.28	34.72	14.28	49.08	130	180	Peak

ANTENNA POLARITY & TEST DISTANCE: VERTICAL AT 3 M										
FREQ. (MHz)	EMISSION LEVEL (dBuV/m)	READ LEVEL (dBuV)	LIMIT (dBuV/m)	MARGIN (dB)	ANTENNA FACTOR (dB /m)	CABLE LOSS (dB)	PREAMP FACTOR (dB)	ANTENNA HEIGHT (cm)	TABLE ANGLE (Degree)	REMARK
5135	41.36	42.24	54.00	-12.64	34.46	13.67	49.01	100	110	Average
5135	52.20	53.08	74.00	-21.80	34.46	13.67	49.01	100	110	Peak
5290	86.01	86.31			34.65	14.11	49.06	100	110	Average
5290	99.36	99.66			34.65	14.11	49.06	100	110	Peak
5350	43.84	43.92	54.00	-10.16	34.72	14.28	49.08	100	110	Average
5350	56.29	56.37	74.00	-17.71	34.72	14.28	49.08	100	110	Peak

REMARKS:

- Emission Level = Read Level+ Antenna Factor + Cable Loss- Preamp Factor
Margin value = Emission level – Limit value.
- 5290MHz: Fundamental frequency.



ABOVE 1GHz WORST-CASE DATA: Band 3

802.11a

CHANNEL	TX Channel 100	DETECTOR FUNCTION	Peak (PK)
FREQUENCY RANGE	1GHz ~ 40GHz		Average (AV)

ANTENNA POLARITY & TEST DISTANCE: HORIZONTAL AT 3 M										
FREQ. (MHz)	EMISSION LEVEL (dBuV/m)	READ LEVEL (dBuV)	LIMIT (dBuV/m)	MARGIN (dB)	ANTENNA FACTOR (dB /m)	CABLE LOSS (dB)	PREAMP FACTOR (dB)	ANTENNA HEIGHT (cm)	TABLE ANGLE (Degree)	REMARK
5447	44.93	44.63	54.00	-9.07	34.84	14.56	49.10	120	250	Average
5447	53.16	52.86	74.00	-20.84	34.84	14.56	49.10	120	250	Peak
#5470	49.84	49.47	68.30	-18.64	34.86	14.62	49.11	120	250	Peak
5500	94.63	94.14			34.90	14.71	49.12	120	250	Average
5500	104.45	103.96			34.90	14.71	49.12	120	250	Peak
#5725	53.67	51.46	68.30	-14.63	35.17	16.18	49.14	120	250	Peak
ANTENNA POLARITY & TEST DISTANCE: VERTICAL AT 3 M										
FREQ. (MHz)	EMISSION LEVEL (dBuV/m)	READ LEVEL (dBuV)	LIMIT (dBuV/m)	MARGIN (dB)	ANTENNA FACTOR (dB /m)	CABLE LOSS (dB)	PREAMP FACTOR (dB)	ANTENNA HEIGHT (cm)	TABLE ANGLE (Degree)	REMARK
5447	43.52	43.22	54.00	-10.48	34.84	14.56	49.10	100	105	Average
5447	53.59	53.29	74.00	-20.41	34.84	14.56	49.10	100	105	Peak
#5470	50.11	49.74	68.30	-18.19	34.86	14.62	49.11	100	105	Peak
5500	94.80	94.31			34.90	14.71	49.12	100	105	Average
5500	104.69	104.20			34.90	14.71	49.12	100	105	Peak
#5725	54.56	52.35	68.30	-13.74	35.17	16.18	49.14	100	105	Peak

REMARKS:

1. Emission Level = Read Level+ Antenna Factor + Cable Loss- Preamp Factor
Margin value = Emission level – Limit value.
2. 5500MHz: Fundamental frequency.
3. #: Out of restricted band.



CHANNEL	TX Channel 116	DETECTOR FUNCTION	Peak (PK)
FREQUENCY RANGE	1GHz ~ 40GHz		Average (AV)

ANTENNA POLARITY & TEST DISTANCE: HORIZONTAL AT 3 M

FREQ. (MHz)	EMISSION LEVEL (dBuV/m)	READ LEVEL (dBuV)	LIMIT (dBuV/m)	MARGIN (dB)	ANTENNA FACTOR (dB /m)	CABLE LOSS (dB)	PREAMP FACTOR (dB)	ANTENNA HEIGHT (cm)	TABLE ANGLE (Degree)	REMARK
5460	41.77	41.43	54.00	-12.23	34.85	14.60	49.11	140	250	Average
5460	51.51	51.17	74.00	-22.49	34.85	14.60	49.11	140	250	Peak
#5470	52.41	52.04	68.30	-15.89	34.86	14.62	49.11	140	250	Peak
5580	95.06	93.96			35.00	15.23	49.13	140	250	Average
5580	104.34	103.24			35.00	15.23	49.13	140	250	Peak
#5725	55.22	53.01	68.30	-13.08	35.17	16.18	49.14	140	250	Peak

ANTENNA POLARITY & TEST DISTANCE: VERTICAL AT 3 M

FREQ. (MHz)	EMISSION LEVEL (dBuV/m)	READ LEVEL (dBuV)	LIMIT (dBuV/m)	MARGIN (dB)	ANTENNA FACTOR (dB /m)	CABLE LOSS (dB)	PREAMP FACTOR (dB)	ANTENNA HEIGHT (cm)	TABLE ANGLE (Degree)	REMARK
5460	41.87	41.53	54.00	-12.13	34.85	14.60	49.11	170	90	Average
5460	51.60	51.26	74.00	-22.40	34.85	14.60	49.11	170	90	Peak
#5470	52.73	52.36	68.30	-15.57	34.86	14.62	49.11	170	90	Peak
5580	96.45	95.35			35.00	15.23	49.13	170	90	Average
5580	105.01	103.91			35.00	15.23	49.13	170	90	Peak
#5725	56.53	54.32	68.30	-11.77	35.17	16.18	49.14	170	90	Peak

REMARKS:

1. Emission Level = Read Level+ Antenna Factor + Cable Loss- Preamp Factor
Margin value = Emission level – Limit value.
2. 5580MHz: Fundamental frequency.
3. #: Out of restricted band.



CHANNEL	TX Channel 140	DETECTOR FUNCTION	Peak (PK)
FREQUENCY RANGE	1GHz ~ 40GHz		Average (AV)

ANTENNA POLARITY & TEST DISTANCE: HORIZONTAL AT 3 M										
FREQ. (MHz)	EMISSION LEVEL (dBuV/m)	READ LEVEL (dBuV)	LIMIT (dBuV/m)	MARGIN (dB)	ANTENNA FACTOR (dB /m)	CABLE LOSS (dB)	PREAMP FACTOR (dB)	ANTENNA HEIGHT (cm)	TABLE ANGLE (Degree)	REMARK
5460	41.87	41.53	54.00	-12.13	34.85	14.60	49.11	120	248	Average
5460	52.18	51.84	74.00	-21.82	34.85	14.60	49.11	120	248	Peak
#5470	52.07	51.70	68.30	-16.23	34.86	14.62	49.11	120	248	Peak
5700	96.37	94.36			35.14	16.01	49.14	120	248	Average
5700	104.60	102.59			35.14	16.01	49.14	120	248	Peak
#5725	54.05	51.84	68.30	-14.25	35.17	16.18	49.14	120	248	Peak

ANTENNA POLARITY & TEST DISTANCE: VERTICAL AT 3 M										
FREQ. (MHz)	EMISSION LEVEL (dBuV/m)	READ LEVEL (dBuV)	LIMIT (dBuV/m)	MARGIN (dB)	ANTENNA FACTOR (dB /m)	CABLE LOSS (dB)	PREAMP FACTOR (dB)	ANTENNA HEIGHT (cm)	TABLE ANGLE (Degree)	REMARK
5460	41.80	41.46	54.00	-12.20	34.85	14.60	49.11	180	80	Average
5460	52.88	52.54	74.00	-21.12	34.85	14.60	49.11	180	80	Peak
#5470	53.06	52.69	68.30	-15.24	34.86	14.62	49.11	180	80	Peak
5700	97.07	95.06			35.14	16.01	49.14	180	80	Average
5700	105.32	103.31			35.14	16.01	49.14	180	80	Peak
#5725	53.55	51.34	68.30	-14.75	35.17	16.18	49.14	180	80	Peak

REMARKS:

1. Emission Level = Read Level+ Antenna Factor + Cable Loss- Preamp Factor
Margin value = Emission level – Limit value.
2. 5700MHz: Fundamental frequency.
3. #: Out of restricted band.



802.11n (20MHz)

CHANNEL	TX Channel 100	DETECTOR FUNCTION	Peak (PK)
FREQUENCY RANGE	1GHz ~ 40GHz		Average (AV)

ANTENNA POLARITY & TEST DISTANCE: HORIZONTAL AT 3 M

FREQ. (MHz)	EMISSION LEVEL (dBuV/m)	READ LEVEL (dBuV)	LIMIT (dBuV/m)	MARGIN (dB)	ANTENNA FACTOR (dB /m)	CABLE LOSS (dB)	PREAMP FACTOR (dB)	ANTENNA HEIGHT (cm)	TABLE ANGLE (Degree)	REMARK
5448	45.02	44.72	54.00	-8.98	34.84	14.56	49.10	140	240	Average
5448	54.46	54.16	74.00	-19.54	34.84	14.56	49.10	140	240	Peak
#5470	52.17	51.80	68.30	-16.13	34.86	14.62	49.11	140	240	Peak
5500	93.71	93.22			34.90	14.71	49.12	140	240	Average
5500	101.71	101.22			34.90	14.71	49.12	140	240	Peak
#5725	55.75	53.54	68.30	-12.55	35.17	16.18	49.14	140	240	Peak

ANTENNA POLARITY & TEST DISTANCE: VERTICAL AT 3 M

FREQ. (MHz)	EMISSION LEVEL (dBuV/m)	READ LEVEL (dBuV)	LIMIT (dBuV/m)	MARGIN (dB)	ANTENNA FACTOR (dB /m)	CABLE LOSS (dB)	PREAMP FACTOR (dB)	ANTENNA HEIGHT (cm)	TABLE ANGLE (Degree)	REMARK
5448	43.91	43.61	54.00	-10.09	34.84	14.56	49.10	100	100	Average
5448	53.03	52.73	74.00	-20.97	34.84	14.56	49.10	100	100	Peak
#5470	50.84	50.47	68.30	-17.46	34.86	14.62	49.11	100	100	Peak
5500	94.76	94.27			34.90	14.71	49.12	100	100	Average
5500	103.55	103.06			34.90	14.71	49.12	100	100	Peak
#5725	57.32	55.11	68.30	-10.98	35.17	16.18	49.14	100	100	Peak

REMARKS:

1. Emission Level = Read Level+ Antenna Factor + Cable Loss- Preamp Factor
Margin value = Emission level – Limit value.
2. 5500MHz: Fundamental frequency.
3. #: Out of restricted band.



CHANNEL	TX Channel 116	DETECTOR FUNCTION	Peak (PK)
FREQUENCY RANGE	1GHz ~ 40GHz		Average (AV)

ANTENNA POLARITY & TEST DISTANCE: HORIZONTAL AT 3 M										
FREQ. (MHz)	EMISSION LEVEL (dBuV/m)	READ LEVEL (dBuV)	LIMIT (dBuV/m)	MARGIN (dB)	ANTENNA FACTOR (dB /m)	CABLE LOSS (dB)	PREAMP FACTOR (dB)	ANTENNA HEIGHT (cm)	TABLE ANGLE (Degree)	REMARK
5460	41.95	41.61	54.00	-12.05	34.85	14.60	49.11	160	238	Average
5460	51.97	51.63	74.00	-22.03	34.85	14.60	49.11	160	238	Peak
#5470	49.69	49.32	68.30	-18.61	34.86	14.62	49.11	160	238	Peak
5580	93.86	92.76			35.00	15.23	49.13	160	238	Average
5580	103.06	101.96			35.00	15.23	49.13	160	238	Peak
#5725	56.32	54.11	68.30	-11.98	35.17	16.18	49.14	160	238	Peak

ANTENNA POLARITY & TEST DISTANCE: VERTICAL AT 3 M										
FREQ. (MHz)	EMISSION LEVEL (dBuV/m)	READ LEVEL (dBuV)	LIMIT (dBuV/m)	MARGIN (dB)	ANTENNA FACTOR (dB /m)	CABLE LOSS (dB)	PREAMP FACTOR (dB)	ANTENNA HEIGHT (cm)	TABLE ANGLE (Degree)	REMARK
5450	41.84	41.53	54.00	-12.16	34.84	14.57	49.10	100	90	Average
5450	52.35	52.04	74.00	-21.65	34.84	14.57	49.10	100	90	Peak
#5470	51.84	51.47	68.30	-16.46	34.86	14.62	49.11	100	90	Peak
5580	94.98	93.88			35.00	15.23	49.13	100	90	Average
5580	104.40	103.30			35.00	15.23	49.13	100	90	Peak
#5725	53.93	51.72	68.30	-14.37	35.17	16.18	49.14	100	90	Peak

REMARKS:

1. Emission Level = Read Level+ Antenna Factor + Cable Loss- Preamp Factor
Margin value = Emission level – Limit value.
2. 5580MHz: Fundamental frequency.
3. #: Out of restricted band.



CHANNEL	TX Channel 140	DETECTOR FUNCTION	Peak (PK)
FREQUENCY RANGE	1GHz ~ 40GHz		Average (AV)

ANTENNA POLARITY & TEST DISTANCE: HORIZONTAL AT 3 M										
FREQ. (MHz)	EMISSION LEVEL (dBuV/m)	READ LEVEL (dBuV)	LIMIT (dBuV/m)	MARGIN (dB)	ANTENNA FACTOR (dB /m)	CABLE LOSS (dB)	PREAMP FACTOR (dB)	ANTENNA HEIGHT (cm)	TABLE ANGLE (Degree)	REMARK
5408	41.76	41.61	54.00	-12.24	34.79	14.45	49.09	140	245	Average
5408	51.74	51.59	74.00	-22.26	34.79	14.45	49.09	140	245	Peak
#5470	50.08	49.71	68.30	-18.22	34.86	14.62	49.11	140	245	Peak
5700	96.15	94.14			35.14	16.01	49.14	140	245	Average
5700	105.30	103.29			35.14	16.01	49.14	140	245	Peak
#5725	58.61	56.40	68.30	-9.69	35.17	16.18	49.14	140	245	Peak

ANTENNA POLARITY & TEST DISTANCE: VERTICAL AT 3 M										
FREQ. (MHz)	EMISSION LEVEL (dBuV/m)	READ LEVEL (dBuV)	LIMIT (dBuV/m)	MARGIN (dB)	ANTENNA FACTOR (dB /m)	CABLE LOSS (dB)	PREAMP FACTOR (dB)	ANTENNA HEIGHT (cm)	TABLE ANGLE (Degree)	REMARK
5418	41.69	41.51	54.00	-12.31	34.80	14.48	49.10	110	70	Average
5418	52.53	52.35	74.00	-21.47	34.80	14.48	49.10	110	70	Peak
#5470	49.41	49.04	68.30	-18.89	34.86	14.62	49.11	110	70	Peak
5700	96.40	94.39			35.14	16.01	49.14	110	70	Average
5700	105.70	103.69			35.14	16.01	49.14	110	70	Peak
#5725	60.28	58.07	68.30	-8.02	35.17	16.18	49.14	110	70	Peak

REMARKS:

1. Emission Level = Read Level+ Antenna Factor + Cable Loss- Preamp Factor
Margin value = Emission level – Limit value.
2. 5700MHz: Fundamental frequency.
3. #: Out of restricted band.



802.11n (40MHz)

CHANNEL	TX Channel 102	DETECTOR FUNCTION	Peak (PK)
FREQUENCY RANGE	1GHz ~ 40GHz		Average (AV)

ANTENNA POLARITY & TEST DISTANCE: HORIZONTAL AT 3 M										
FREQ. (MHz)	EMISSION LEVEL (dBuV/m)	READ LEVEL (dBuV)	LIMIT (dBuV/m)	MARGIN (dB)	ANTENNA FACTOR (dB /m)	CABLE LOSS (dB)	PREAMP FACTOR (dB)	ANTENNA HEIGHT (cm)	TABLE ANGLE (Degree)	REMARK
5460	49.64	49.30	74.00	-24.36	34.85	14.60	49.11	180	240	Peak
#5470	42.35	42.21	68.30	-25.95	34.79	14.44	49.09	180	240	Average
#5470	52.07	51.93	68.30	-16.23	34.79	14.44	49.09	180	240	Peak
5510	88.33	87.76			34.91	14.78	49.12	180	240	Average
5510	98.14	97.57			34.91	14.78	49.12	180	240	Peak
#5725	55.89	53.68	68.30	-12.41	35.17	16.18	49.14	180	240	Peak

ANTENNA POLARITY & TEST DISTANCE: VERTICAL AT 3 M										
FREQ. (MHz)	EMISSION LEVEL (dBuV/m)	READ LEVEL (dBuV)	LIMIT (dBuV/m)	MARGIN (dB)	ANTENNA FACTOR (dB /m)	CABLE LOSS (dB)	PREAMP FACTOR (dB)	ANTENNA HEIGHT (cm)	TABLE ANGLE (Degree)	REMARK
5460	41.84	41.70	54.00	-12.16	34.79	14.44	49.09	100	103	Average
5460	51.98	51.84	74.00	-22.02	34.79	14.44	49.09	100	103	Peak
#5470	51.10	50.73	68.30	-17.20	34.86	14.62	49.11	100	103	Peak
5510	89.76	89.19			34.91	14.78	49.12	100	103	Average
5510	101.06	100.49			34.91	14.78	49.12	100	103	Peak
#5725	54.79	52.58	68.30	-13.51	35.17	16.18	49.14	100	103	Peak

REMARKS:

1. Emission Level = Read Level+ Antenna Factor + Cable Loss- Preamp Factor
Margin value = Emission level – Limit value.
2. 5510MHz: Fundamental frequency.
3. #: Out of restricted band.



CHANNEL	TX Channel 110	DETECTOR FUNCTION	Peak (PK)
FREQUENCY RANGE	1GHz ~ 40GHz		Average (AV)

ANTENNA POLARITY & TEST DISTANCE: HORIZONTAL AT 3 M										
FREQ. (MHz)	EMISSION LEVEL (dBuV/m)	READ LEVEL (dBuV)	LIMIT (dBuV/m)	MARGIN (dB)	ANTENNA FACTOR (dB /m)	CABLE LOSS (dB)	PREAMP FACTOR (dB)	ANTENNA HEIGHT (cm)	TABLE ANGLE (Degree)	REMARK
5447	42.62	42.32	54.00	-11.38	34.84	14.56	49.10	150	240	Average
5447	52.25	51.95	74.00	-21.75	34.84	14.56	49.10	150	240	Peak
#5470	51.63	51.26	68.30	-16.67	34.86	14.62	49.11	150	240	Peak
5550	89.03	88.15			34.96	15.04	49.12	150	240	Average
5550	99.52	98.64			34.96	15.04	49.12	150	240	Peak
#5725	56.38	54.17	68.30	-11.92	35.17	16.18	49.14	150	240	Peak

ANTENNA POLARITY & TEST DISTANCE: VERTICAL AT 3 M										
FREQ. (MHz)	EMISSION LEVEL (dBuV/m)	READ LEVEL (dBuV)	LIMIT (dBuV/m)	MARGIN (dB)	ANTENNA FACTOR (dB /m)	CABLE LOSS (dB)	PREAMP FACTOR (dB)	ANTENNA HEIGHT (cm)	TABLE ANGLE (Degree)	REMARK
5447	42.32	42.02	54.00	-11.68	34.84	14.56	49.10	150	100	Average
5447	52.70	52.40	74.00	-21.30	34.84	14.56	49.10	150	100	Peak
#5470	51.13	50.76	68.30	-17.17	34.86	14.62	49.11	150	100	Peak
5550	90.84	89.96			34.96	15.04	49.12	150	100	Average
5550	101.71	100.83			34.96	15.04	49.12	150	100	Peak
#5725	56.91	54.70	68.30	-11.39	35.17	16.18	49.14	150	100	Peak

REMARKS:

1. Emission Level = Read Level+ Antenna Factor + Cable Loss- Preamp Factor
Margin value = Emission level – Limit value.
2. 5550MHz: Fundamental frequency.
3. #: Out of restricted band.



CHANNEL	TX Channel 134	DETECTOR FUNCTION	Peak (PK)
FREQUENCY RANGE	1GHz ~ 40GHz		Average (AV)

ANTENNA POLARITY & TEST DISTANCE: HORIZONTAL AT 3 M										
FREQ. (MHz)	EMISSION LEVEL (dBuV/m)	READ LEVEL (dBuV)	LIMIT (dBuV/m)	MARGIN (dB)	ANTENNA FACTOR (dB /m)	CABLE LOSS (dB)	PREAMP FACTOR (dB)	ANTENNA HEIGHT (cm)	TABLE ANGLE (Degree)	REMARK
5450	41.44	41.13	54.00	-12.56	34.84	14.57	49.10	140	245	Average
5450	51.71	51.40	74.00	-22.29	34.84	14.57	49.10	140	245	Peak
#5470	51.07	50.70	68.30	-17.60	34.86	14.62	49.11	140	245	Peak
5670	91.06	89.28			35.10	15.82	49.14	140	245	Average
5670	102.33	100.55			35.10	15.82	49.14	140	245	Peak
#5725	55.91	53.70	68.30	-12.39	35.17	16.18	49.14	140	245	Peak

ANTENNA POLARITY & TEST DISTANCE: VERTICAL AT 3 M										
FREQ. (MHz)	EMISSION LEVEL (dBuV/m)	READ LEVEL (dBuV)	LIMIT (dBuV/m)	MARGIN (dB)	ANTENNA FACTOR (dB /m)	CABLE LOSS (dB)	PREAMP FACTOR (dB)	ANTENNA HEIGHT (cm)	TABLE ANGLE (Degree)	REMARK
5451	41.84	41.54	54.00	-12.16	34.84	14.57	49.11	200	80	Average
5451	51.73	51.43	74.00	-22.27	34.84	14.57	49.11	200	80	Peak
#5470	50.72	50.35	68.30	-17.58	34.86	14.62	49.11	200	80	Peak
5670	90.97	89.19			35.10	15.82	49.14	200	80	Average
5670	101.14	99.36			35.10	15.82	49.14	200	80	Peak
#5725	57.85	55.64	68.30	-10.45	35.17	16.18	49.14	200	80	Peak

REMARKS:

1. Emission Level = Read Level+ Antenna Factor + Cable Loss- Preamp Factor
Margin value = Emission level – Limit value.
2. 5670MHz: Fundamental frequency.
3. #: Out of restricted band.



802.11ac (80MHz)

CHANNEL	TX Channel 106	DETECTOR FUNCTION	Peak (PK)
FREQUENCY RANGE	1GHz ~ 40GHz		Average (AV)

ANTENNA POLARITY & TEST DISTANCE: HORIZONTAL AT 3 M										
FREQ. (MHz)	EMISSION LEVEL (dBuV/m)	READ LEVEL (dBuV)	LIMIT (dBuV/m)	MARGIN (dB)	ANTENNA FACTOR (dB /m)	CABLE LOSS (dB)	PREAMP FACTOR (dB)	ANTENNA HEIGHT (cm)	TABLE ANGLE (Degree)	REMARK
5460	44.76	44.42	54.00	-9.24	34.85	14.60	49.11	100	180	Average
5460	56.29	55.95	74.00	-17.71	34.85	14.60	49.11	100	180	Peak
#5470	57.10	56.73	68.30	-11.20	34.86	14.62	49.11	100	180	Peak
5530	84.79	84.06			34.94	14.91	49.12	100	180	Average
5530	98.90	98.17			34.94	14.91	49.12	100	180	Peak
#5725	54.82	52.61	68.30	-13.48	35.17	16.18	49.14	100	180	Peak

ANTENNA POLARITY & TEST DISTANCE: VERTICAL AT 3 M										
FREQ. (MHz)	EMISSION LEVEL (dBuV/m)	READ LEVEL (dBuV)	LIMIT (dBuV/m)	MARGIN (dB)	ANTENNA FACTOR (dB /m)	CABLE LOSS (dB)	PREAMP FACTOR (dB)	ANTENNA HEIGHT (cm)	TABLE ANGLE (Degree)	REMARK
5460	43.15	42.81	54.00	-10.85	34.85	14.60	49.11	132	120	Average
5460	54.28	53.94	74.00	-19.72	34.85	14.60	49.11	132	120	Peak
#5470	54.83	54.46	68.30	-13.47	34.86	14.62	49.11	132	120	Peak
5530	85.23	84.50			34.94	14.91	49.12	132	120	Average
5530	98.49	97.76			34.94	14.91	49.12	132	120	Peak
#5725	53.26	51.05	68.30	-15.04	35.17	16.18	49.14	132	120	Peak

REMARKS:

1. Emission Level = Read Level+ Antenna Factor + Cable Loss- Preamp Factor
Margin value = Emission level – Limit value.
2. 5530MHz: Fundamental frequency.
3. #: Out of restricted band.



ABOVE 1GHz WORST-CASE DATA: Band 4

802.11a

CHANNEL	TX Channel 149	DETECTOR FUNCTION	Peak (PK)
FREQUENCY RANGE	1GHz ~ 40GHz		Average (AV)

ANTENNA POLARITY & TEST DISTANCE: HORIZONTAL AT 3 M										
FREQ. (MHz)	EMISSION LEVEL (dBuV/m)	READ LEVEL (dBuV)	LIMIT (dBuV/m)	MARGIN (dB)	ANTENNA FACTOR (dB /m)	CABLE LOSS (dB)	PREAMP FACTOR (dB)	ANTENNA HEIGHT (cm)	TABLE ANGLE (Degree)	REMARK
5745	95.82	93.46			35.19	16.31	49.14	150	250	Average
5745	105.46	103.10			35.19	16.31	49.14	150	250	Peak
11490	49.53	39.51	54.00	-4.47	39.10	19.08	48.16	100	240	Average
11490	60.15	50.13	74.00	-13.85	39.10	19.08	48.16	100	240	Peak
ANTENNA POLARITY & TEST DISTANCE: VERTICAL AT 3 M										
FREQ. (MHz)	EMISSION LEVEL (dBuV/m)	READ LEVEL (dBuV)	LIMIT (dBuV/m)	MARGIN (dB)	ANTENNA FACTOR (dB /m)	CABLE LOSS (dB)	PREAMP FACTOR (dB)	ANTENNA HEIGHT (cm)	TABLE ANGLE (Degree)	REMARK
5745	96.99	94.63			35.19	16.31	49.14	100	120	Average
5745	105.85	103.49			35.19	16.31	49.14	100	120	Peak
11490	49.52	39.50	54.00	-4.48	39.10	19.08	48.16	100	120	Average
11490	61.12	51.10	74.00	-12.88	39.10	19.08	48.16	100	120	Peak

REMARKS:

- Emission Level = Read Level+ Antenna Factor + Cable Loss- Preamp Factor
Margin value = Emission level – Limit value.
- 5745MHz: Fundamental frequency.



OOBE DATA

802.11a

ANTENNA POLARITY & TEST DISTANCE: HORIZONTAL AT 3 M										
FREQ. (MHz)	EMISSION LEVEL (dBuV/m)	READ LEVEL (dBuV)	LIMIT (dBuV/m)	MARGIN (dB)	ANTENNA FACTOR (dB /m)	CABLE LOSS (dB)	PREAMP FACTOR (dB)	ANTENNA HEIGHT (cm)	TABLE ANGLE (Degree)	REMARK
5648.325	53.66	52.03	68.30	-14.64	35.08	15.68	49.13	150	250	Peak
5929.525	56.23	52.46	68.30	-12.07	35.42	17.51	49.16	150	250	Peak
ANTENNA POLARITY & TEST DISTANCE: VERTICAL AT 3 M										
FREQ. (MHz)	EMISSION LEVEL (dBuV/m)	READ LEVEL (dBuV)	LIMIT (dBuV/m)	MARGIN (dB)	ANTENNA FACTOR (dB /m)	CABLE LOSS (dB)	PREAMP FACTOR (dB)	ANTENNA HEIGHT (cm)	TABLE ANGLE (Degree)	REMARK
5640.725	54.28	52.71	68.30	-14.02	35.07	15.63	49.13	180	105	Peak
5932.85	56.69	52.90	68.30	-11.61	35.42	17.53	49.16	180	105	Peak

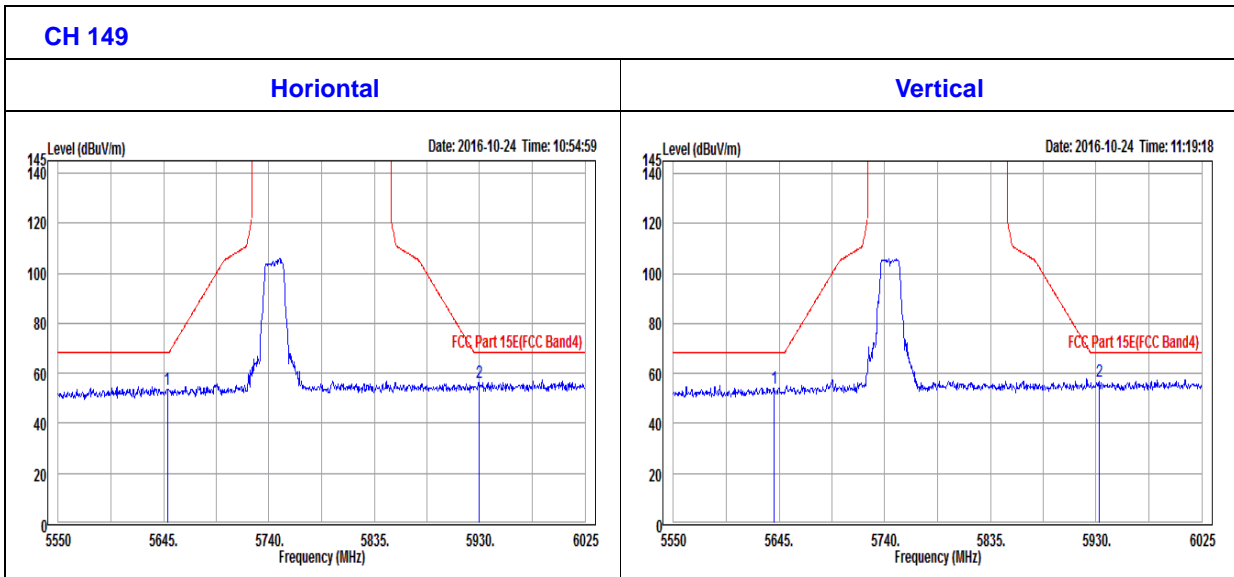



CHANNEL	TX Channel 157	DETECTOR FUNCTION	Peak (PK)
FREQUENCY RANGE	1GHz ~ 40GHz		Average (AV)

ANTENNA POLARITY & TEST DISTANCE: HORIZONTAL AT 3 M										
FREQ. (MHz)	EMISSION LEVEL (dBuV/m)	READ LEVEL (dBuV)	LIMIT (dBuV/m)	MARGIN (dB)	ANTENNA FACTOR (dB /m)	CABLE LOSS (dB)	PREAMP FACTOR (dB)	ANTENNA HEIGHT (cm)	TABLE ANGLE (Degree)	REMARK
5785	96.33	93.67			35.24	16.57	49.15	140	250	Average
5785	105.40	102.74			35.24	16.57	49.15	140	250	Peak
11570	49.54	39.43	54.00	-4.46	39.16	19.12	48.17	100	220	Average
11570	58.92	48.81	74.00	-15.08	39.16	19.12	48.17	100	220	Peak
ANTENNA POLARITY & TEST DISTANCE: VERTICAL AT 3 M										
FREQ. (MHz)	EMISSION LEVEL (dBuV/m)	READ LEVEL (dBuV)	LIMIT (dBuV/m)	MARGIN (dB)	ANTENNA FACTOR (dB /m)	CABLE LOSS (dB)	PREAMP FACTOR (dB)	ANTENNA HEIGHT (cm)	TABLE ANGLE (Degree)	REMARK
5785	96.54	93.88			35.24	16.57	49.15	180	80	Average
5785	105.76	103.10			35.24	16.57	49.15	180	80	Peak
11570	49.50	39.39	54.00	-4.50	39.16	19.12	48.17	100	150	Average
11570	60.47	50.36	74.00	-13.53	39.16	19.12	48.17	100	150	Peak

REMARKS:

- Emission Level = Read Level+ Antenna Factor + Cable Loss- Preamp Factor
Margin value = Emission level – Limit value.
- 5785MHz: Fundamental frequency.



OOBE DATA

802.11a

ANTENNA POLARITY & TEST DISTANCE: HORIZONTAL AT 3 M										
FREQ. (MHz)	EMISSION LEVEL (dBuV/m)	READ LEVEL (dBuV)	LIMIT (dBuV/m)	MARGIN (dB)	ANTENNA FACTOR (dB /m)	CABLE LOSS (dB)	PREAMP FACTOR (dB)	ANTENNA HEIGHT (cm)	TABLE ANGLE (Degree)	REMARK
5645	52.38	50.78	68.30	-15.92	35.07	15.66	49.13	140	250	Peak
5930	54.38	50.61	68.30	-13.92	35.42	17.51	49.16	140	250	Peak
ANTENNA POLARITY & TEST DISTANCE: VERTICAL AT 3 M										
FREQ. (MHz)	EMISSION LEVEL (dBuV/m)	READ LEVEL (dBuV)	LIMIT (dBuV/m)	MARGIN (dB)	ANTENNA FACTOR (dB /m)	CABLE LOSS (dB)	PREAMP FACTOR (dB)	ANTENNA HEIGHT (cm)	TABLE ANGLE (Degree)	REMARK
5636.925	54.63	53.10	68.30	-13.67	35.06	15.60	49.13	180	80	Peak
5929.525	55.53	51.76	68.30	-12.77	35.42	17.51	49.16	180	80	Peak

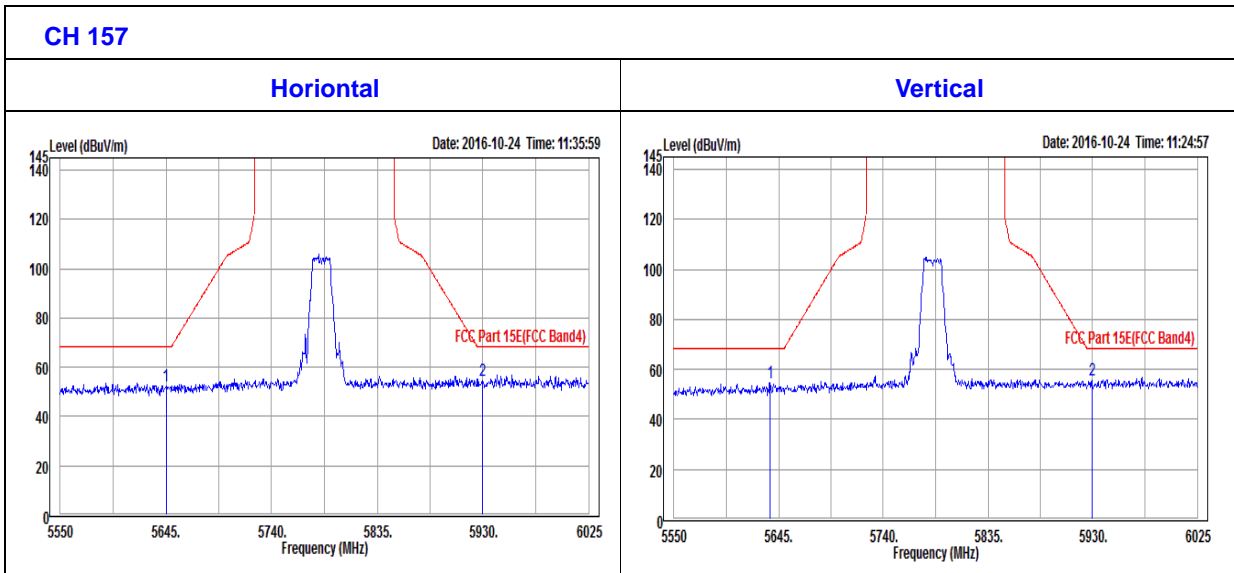



CHANNEL	TX Channel 165	DETECTOR FUNCTION	Peak (PK)
FREQUENCY RANGE	1GHz ~ 40GHz		Average (AV)

ANTENNA POLARITY & TEST DISTANCE: HORIZONTAL AT 3 M										
FREQ. (MHz)	EMISSION LEVEL (dBuV/m)	READ LEVEL (dBuV)	LIMIT (dBuV/m)	MARGIN (dB)	ANTENNA FACTOR (dB /m)	CABLE LOSS (dB)	PREAMP FACTOR (dB)	ANTENNA HEIGHT (cm)	TABLE ANGLE (Degree)	REMARK
5825	97.03	94.06			35.29	16.83	49.15	140	248	Average
5825	106.53	103.56			35.29	16.83	49.15	140	248	Peak
11650	48.56	38.36	54.00	-5.44	39.22	19.16	48.18	100	270	Average
11650	60.15	49.95	74.00	-13.85	39.22	19.16	48.18	100	270	Peak
ANTENNA POLARITY & TEST DISTANCE: VERTICAL AT 3 M										
FREQ. (MHz)	EMISSION LEVEL (dBuV/m)	READ LEVEL (dBuV)	LIMIT (dBuV/m)	MARGIN (dB)	ANTENNA FACTOR (dB /m)	CABLE LOSS (dB)	PREAMP FACTOR (dB)	ANTENNA HEIGHT (cm)	TABLE ANGLE (Degree)	REMARK
5825	97.49	94.52			35.29	16.83	49.15	200	80	Average
5825	105.98	103.01			35.29	16.83	49.15	200	80	Peak
11650	50.09	39.89	54.00	-3.91	39.22	19.16	48.18	100	96	Average
11650	60.99	50.79	74.00	-13.01	39.22	19.16	48.18	100	96	Peak

REMARKS:

- Emission Level = Read Level+ Antenna Factor + Cable Loss- Preamp Factor
Margin value = Emission level – Limit value.
- 5825MHz: Fundamental frequency.



OOBE DATA

802.11a

ANTENNA POLARITY & TEST DISTANCE: HORIZONTAL AT 3 M										
FREQ. (MHz)	EMISSION LEVEL (dBuV/m)	READ LEVEL (dBuV)	LIMIT (dBuV/m)	MARGIN (dB)	ANTENNA FACTOR (dB /m)	CABLE LOSS (dB)	PREAMP FACTOR (dB)	ANTENNA HEIGHT (cm)	TABLE ANGLE (Degree)	REMARK
5646.9	52.53	50.91	68.30	-15.77	35.08	15.67	49.13	140	248	Peak
5928.575	54.80	51.05	68.30	-13.50	35.41	17.50	49.16	140	248	Peak
ANTENNA POLARITY & TEST DISTANCE: VERTICAL AT 3 M										
FREQ. (MHz)	EMISSION LEVEL (dBuV/m)	READ LEVEL (dBuV)	LIMIT (dBuV/m)	MARGIN (dB)	ANTENNA FACTOR (dB /m)	CABLE LOSS (dB)	PREAMP FACTOR (dB)	ANTENNA HEIGHT (cm)	TABLE ANGLE (Degree)	REMARK
5639.3	54.62	53.06	68.30	-13.68	35.07	15.62	49.13	200	80	Peak
5928.1	56.22	52.47	68.30	-12.08	35.41	17.50	49.16	200	80	Peak

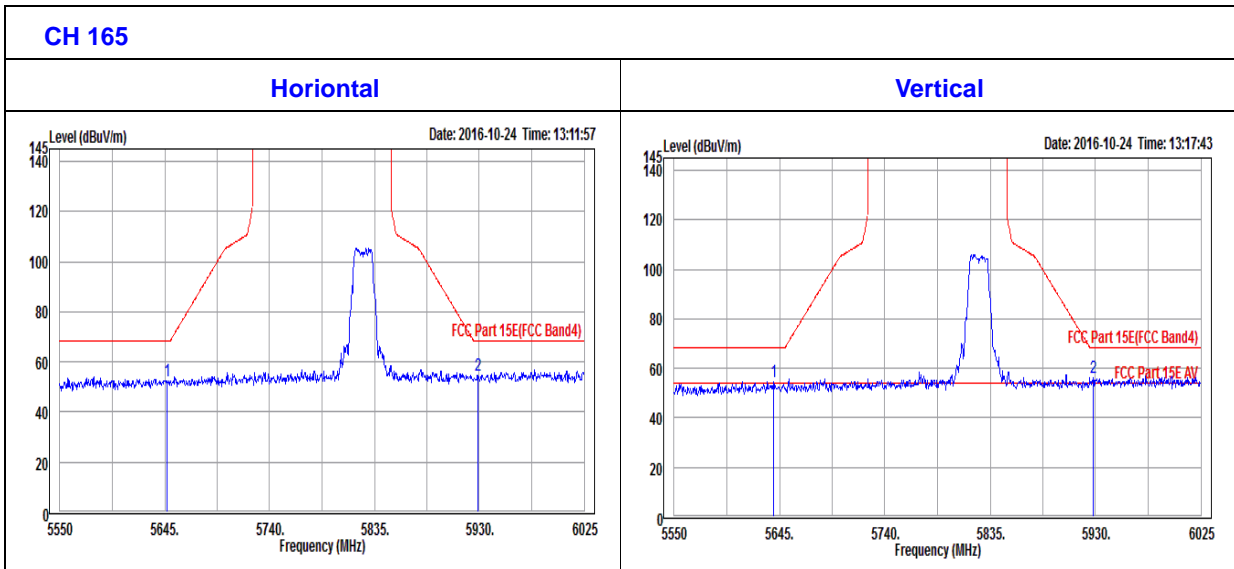



802.11n (20MHz)

CHANNEL	TX Channel 149	DETECTOR FUNCTION	Peak (PK)
FREQUENCY RANGE	1GHz ~ 40GHz		Average (AV)

ANTENNA POLARITY & TEST DISTANCE: HORIZONTAL AT 3 M										
FREQ. (MHz)	EMISSION LEVEL (dBuV/m)	READ LEVEL (dBuV)	LIMIT (dBuV/m)	MARGIN (dB)	ANTENNA FACTOR (dB /m)	CABLE LOSS (dB)	PREAMP FACTOR (dB)	ANTENNA HEIGHT (cm)	TABLE ANGLE (Degree)	REMARK
5745	96.22	93.86			35.19	16.31	49.14	140	250	Average
5745	105.41	103.05			35.19	16.31	49.14	140	250	Peak
11490	48.87	38.85	54.00	-5.13	39.10	19.08	48.16	100	260	Average
11490	61.26	51.24	74.00	-12.74	39.10	19.08	48.16	100	260	Peak
ANTENNA POLARITY & TEST DISTANCE: VERTICAL AT 3 M										
FREQ. (MHz)	EMISSION LEVEL (dBuV/m)	READ LEVEL (dBuV)	LIMIT (dBuV/m)	MARGIN (dB)	ANTENNA FACTOR (dB /m)	CABLE LOSS (dB)	PREAMP FACTOR (dB)	ANTENNA HEIGHT (cm)	TABLE ANGLE (Degree)	REMARK
5745	97.13	94.77			35.19	16.31	49.14	210	100	Average
5745	105.95	103.59			35.19	16.31	49.14	210	100	Peak
11490	49.27	39.25	54.00	-4.73	39.10	19.08	48.16	100	112	Average
11490	60.47	50.45	74.00	-13.53	39.10	19.08	48.16	100	112	Peak

REMARKS:

- Emission Level = Read Level+ Antenna Factor + Cable Loss- Preamp Factor
Margin value = Emission level – Limit value.
- 5745MHz: Fundamental frequency.



OOBE DATA

802.11n (20MHZ)

ANTENNA POLARITY & TEST DISTANCE: HORIZONTAL AT 3 M										
FREQ. (MHz)	EMISSION LEVEL (dBuV/m)	READ LEVEL (dBuV)	LIMIT (dBuV/m)	MARGIN (dB)	ANTENNA FACTOR (dB /m)	CABLE LOSS (dB)	PREAMP FACTOR (dB)	ANTENNA HEIGHT (cm)	TABLE ANGLE (Degree)	REMARK
5641.675	54.28	52.71	68.3	-14.02	35.07	15.63	49.13	140	250	Peak
5934.75	57.45	53.65	68.3	-10.85	35.42	17.54	49.16	140	250	Peak
ANTENNA POLARITY & TEST DISTANCE: VERTICAL AT 3 M										
FREQ. (MHz)	EMISSION LEVEL (dBuV/m)	READ LEVEL (dBuV)	LIMIT (dBuV/m)	MARGIN (dB)	ANTENNA FACTOR (dB /m)	CABLE LOSS (dB)	PREAMP FACTOR (dB)	ANTENNA HEIGHT (cm)	TABLE ANGLE (Degree)	REMARK
5645	55.22	53.62	68.3	-13.08	35.07	15.66	49.13	210	100	Peak
5930.95	55.43	51.65	68.3	-12.87	35.42	17.52	49.16	210	100	Peak

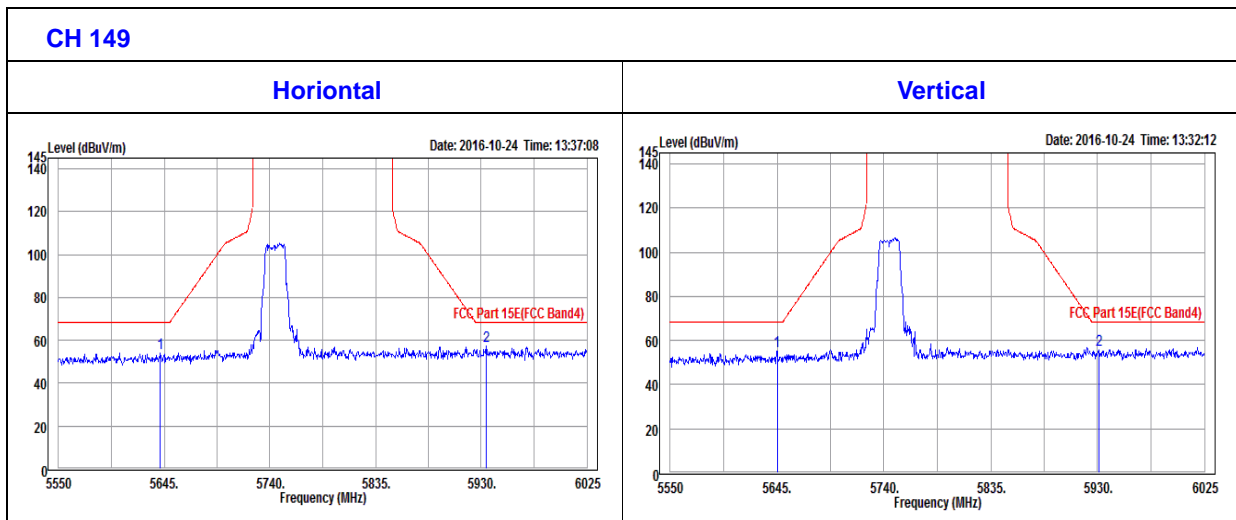



CHANNEL	TX Channel 157	DETECTOR FUNCTION	Peak (PK)
FREQUENCY RANGE	1GHz ~ 40GHz		Average (AV)

ANTENNA POLARITY & TEST DISTANCE: HORIZONTAL AT 3 M										
FREQ. (MHz)	EMISSION LEVEL (dBuV/m)	READ LEVEL (dBuV)	LIMIT (dBuV/m)	MARGIN (dB)	ANTENNA FACTOR (dB /m)	CABLE LOSS (dB)	PREAMP FACTOR (dB)	ANTENNA HEIGHT (cm)	TABLE ANGLE (Degree)	REMARK
5785	96.86	94.20			35.24	16.57	49.15	130	250	Average
5785	106.08	103.42			35.24	16.57	49.15	130	250	Peak
11570	49.07	38.96	54.00	-4.93	39.16	19.12	48.17	100	260	Average
11570	61.16	51.05	74.00	-12.84	39.16	19.12	48.17	100	260	Peak

ANTENNA POLARITY & TEST DISTANCE: VERTICAL AT 3 M										
FREQ. (MHz)	EMISSION LEVEL (dBuV/m)	READ LEVEL (dBuV)	LIMIT (dBuV/m)	MARGIN (dB)	ANTENNA FACTOR (dB /m)	CABLE LOSS (dB)	PREAMP FACTOR (dB)	ANTENNA HEIGHT (cm)	TABLE ANGLE (Degree)	REMARK
5785	96.44	93.78			35.24	16.57	49.15	200	100	Average
5785	105.26	102.60			35.24	16.57	49.15	200	100	Peak
11570	49.47	39.36	54.00	-4.53	39.16	19.12	48.17	100	148	Average
11570	61.00	50.89	74.00	-13.00	39.16	19.12	48.17	100	148	Peak

REMARKS:

- Emission Level = Read Level+ Antenna Factor + Cable Loss- Preamp Factor
Margin value = Emission level – Limit value.
- 5785MHz: Fundamental frequency.



OOBE DATA

802.11n (20MHZ)

ANTENNA POLARITY & TEST DISTANCE: HORIZONTAL AT 3 M										
FREQ. (MHz)	EMISSION LEVEL (dBuV/m)	READ LEVEL (dBuV)	LIMIT (dBuV/m)	MARGIN (dB)	ANTENNA FACTOR (dB /m)	CABLE LOSS (dB)	PREAMP FACTOR (dB)	ANTENNA HEIGHT (cm)	TABLE ANGLE (Degree)	REMARK
5643.575	54.38	52.79	68.3	-13.92	35.07	15.65	49.13	130	250	Peak
5930.475	54.57	50.79	68.3	-13.73	35.42	17.52	49.16	130	250	Peak
ANTENNA POLARITY & TEST DISTANCE: VERTICAL AT 3 M										
FREQ. (MHz)	EMISSION LEVEL (dBuV/m)	READ LEVEL (dBuV)	LIMIT (dBuV/m)	MARGIN (dB)	ANTENNA FACTOR (dB /m)	CABLE LOSS (dB)	PREAMP FACTOR (dB)	ANTENNA HEIGHT (cm)	TABLE ANGLE (Degree)	REMARK
5649.275	53.57	51.94	68.3	-14.73	35.08	15.68	49.13	200	100	Peak
5936.175	56.17	52.36	68.3	-12.13	35.42	17.55	49.16	200	100	Peak

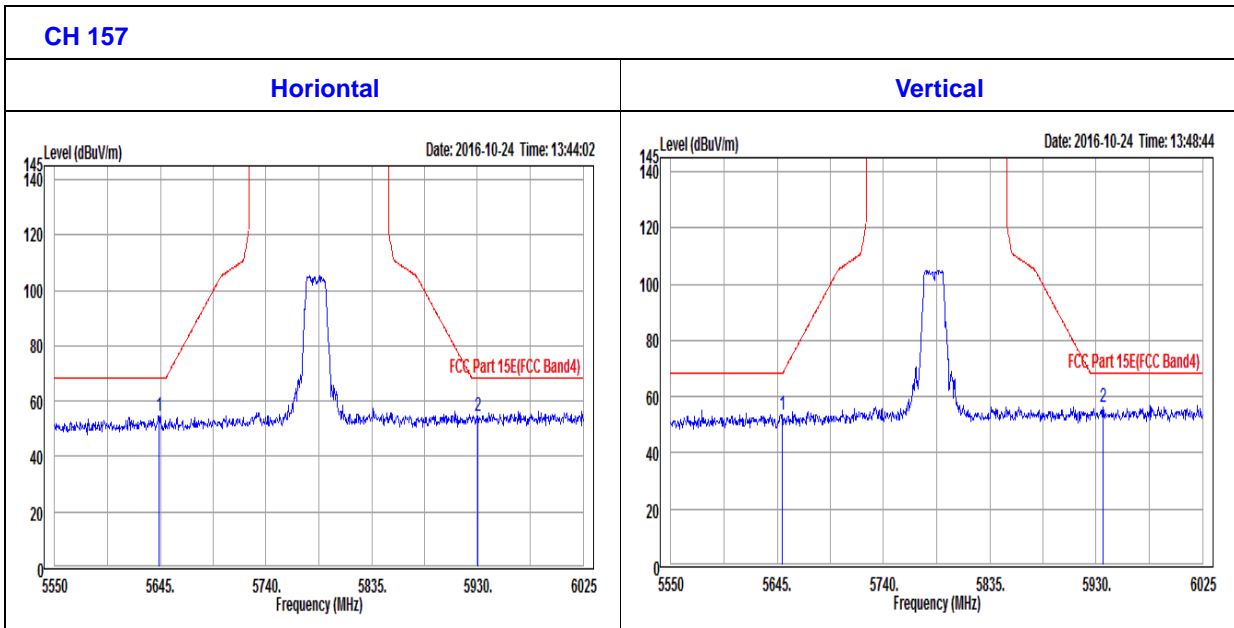



CHANNEL	TX Channel 165	DETECTOR FUNCTION	Peak (PK)
FREQUENCY RANGE	1GHz ~ 40GHz		Average (AV)

ANTENNA POLARITY & TEST DISTANCE: HORIZONTAL AT 3 M										
FREQ. (MHz)	EMISSION LEVEL (dBuV/m)	READ LEVEL (dBuV)	LIMIT (dBuV/m)	MARGIN (dB)	ANTENNA FACTOR (dB /m)	CABLE LOSS (dB)	PREAMP FACTOR (dB)	ANTENNA HEIGHT (cm)	TABLE ANGLE (Degree)	REMARK
5825	95.62	92.65			35.29	16.83	49.15	148	248	Average
5825	104.83	101.86			35.29	16.83	49.15	148	248	Peak
11650	49.61	39.41	54.00	-4.39	39.22	19.16	48.18	100	210	Average
11650	61.56	51.36	74.00	-12.44	39.22	19.16	48.18	100	210	Peak
ANTENNA POLARITY & TEST DISTANCE: VERTICAL AT 3 M										
FREQ. (MHz)	EMISSION LEVEL (dBuV/m)	READ LEVEL (dBuV)	LIMIT (dBuV/m)	MARGIN (dB)	ANTENNA FACTOR (dB /m)	CABLE LOSS (dB)	PREAMP FACTOR (dB)	ANTENNA HEIGHT (cm)	TABLE ANGLE (Degree)	REMARK
5825	97.01	94.04			35.29	16.83	49.15	200	80	Average
5825	105.56	102.59			35.29	16.83	49.15	200	80	Peak
11650	49.65	39.45	54.00	-4.35	39.22	19.16	48.18	100	80	Average
11650	60.86	50.66	74.00	-13.14	39.22	19.16	48.18	100	80	Peak

REMARKS:

- Emission Level = Read Level+ Antenna Factor + Cable Loss- Preamp Factor
Margin value = Emission level – Limit value.
- 5825MHz: Fundamental frequency.



OOBE DATA

802.11n (20MHZ)

ANTENNA POLARITY & TEST DISTANCE: HORIZONTAL AT 3 M										
FREQ. (MHz)	EMISSION LEVEL (dBuV/m)	READ LEVEL (dBuV)	LIMIT (dBuV/m)	MARGIN (dB)	ANTENNA FACTOR (dB /m)	CABLE LOSS (dB)	PREAMP FACTOR (dB)	ANTENNA HEIGHT (cm)	TABLE ANGLE (Degree)	REMARK
5629.8	53.37	51.88	68.3	-14.93	35.06	15.56	49.13	148	248	Peak
5929.525	56.38	52.61	68.3	-11.92	35.42	17.51	49.16	148	248	Peak
ANTENNA POLARITY & TEST DISTANCE: VERTICAL AT 3 M										
FREQ. (MHz)	EMISSION LEVEL (dBuV/m)	READ LEVEL (dBuV)	LIMIT (dBuV/m)	MARGIN (dB)	ANTENNA FACTOR (dB /m)	CABLE LOSS (dB)	PREAMP FACTOR (dB)	ANTENNA HEIGHT (cm)	TABLE ANGLE (Degree)	REMARK
5645.475	55.24	53.64	68.3	-13.06	35.07	15.66	49.13	200	80	Peak
5926.2	56.09	52.35	68.3	-12.21	35.41	17.49	49.16	200	80	Peak

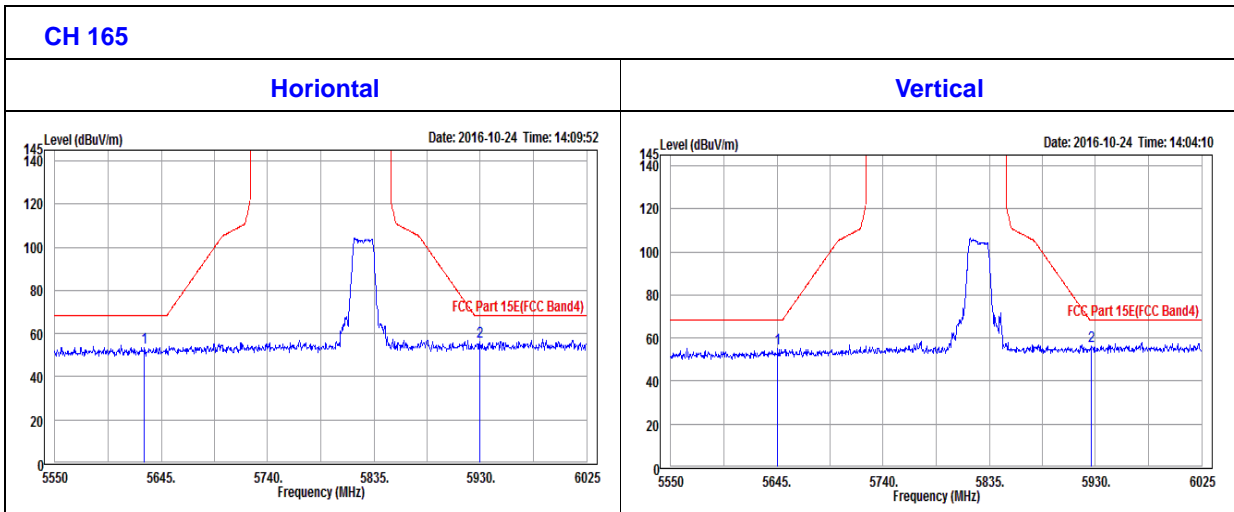



802.11n (40MHz)

CHANNEL	TX Channel 151	DETECTOR FUNCTION	Peak (PK)
FREQUENCY RANGE	1GHz ~ 40GHz		Average (AV)

ANTENNA POLARITY & TEST DISTANCE: HORIZONTAL AT 3 M										
FREQ. (MHz)	EMISSION LEVEL (dBuV/m)	READ LEVEL (dBuV)	LIMIT (dBuV/m)	MARGIN (dB)	ANTENNA FACTOR (dB /m)	CABLE LOSS (dB)	PREAMP FACTOR (dB)	ANTENNA HEIGHT (cm)	TABLE ANGLE (Degree)	REMARK
5755	91.96	89.53			35.21	16.37	49.15	140	248	Average
5755	102.26	99.83			35.21	16.37	49.15	140	248	Peak
11510	48.57	38.53	54.00	-5.43	39.11	19.09	48.16	100	269	Average
11510	61.16	51.12	74.00	-12.84	39.11	19.09	48.16	100	269	Peak
ANTENNA POLARITY & TEST DISTANCE: VERTICAL AT 3 M										
FREQ. (MHz)	EMISSION LEVEL (dBuV/m)	READ LEVEL (dBuV)	LIMIT (dBuV/m)	MARGIN (dB)	ANTENNA FACTOR (dB /m)	CABLE LOSS (dB)	PREAMP FACTOR (dB)	ANTENNA HEIGHT (cm)	TABLE ANGLE (Degree)	REMARK
5755	92.55	90.12			35.21	16.37	49.15	210	103	Average
5755	102.65	100.22			35.21	16.37	49.15	210	103	Peak
11510	49.25	39.21	54.00	-4.75	39.11	19.09	48.16	100	121	Average
11510	61.72	51.68	74.00	-12.28	39.11	19.09	48.16	100	121	Peak

REMARKS:

- Emission Level = Read Level+ Antenna Factor + Cable Loss- Preamp Factor
Margin value = Emission level – Limit value.
- 5755MHz: Fundamental frequency.



OOBE DATA

802.11n (40MHZ)

ANTENNA POLARITY & TEST DISTANCE: HORIZONTAL AT 3 M										
FREQ. (MHz)	EMISSION LEVEL (dBuV/m)	READ LEVEL (dBuV)	LIMIT (dBuV/m)	MARGIN (dB)	ANTENNA FACTOR (dB /m)	CABLE LOSS (dB)	PREAMP FACTOR (dB)	ANTENNA HEIGHT (cm)	TABLE ANGLE (Degree)	REMARK
5641.2	55.41	53.84	68.3	-12.89	35.07	15.63	49.13	140	248	Peak
5930.95	55.32	51.54	68.3	-12.98	35.42	17.52	49.16	140	248	Peak
ANTENNA POLARITY & TEST DISTANCE: VERTICAL AT 3 M										
FREQ. (MHz)	EMISSION LEVEL (dBuV/m)	READ LEVEL (dBuV)	LIMIT (dBuV/m)	MARGIN (dB)	ANTENNA FACTOR (dB /m)	CABLE LOSS (dB)	PREAMP FACTOR (dB)	ANTENNA HEIGHT (cm)	TABLE ANGLE (Degree)	REMARK
5645	55	53.4	68.3	-13.3	35.07	15.66	49.13	210	103	Peak
5939.5	56.89	53.04	68.3	-11.41	35.43	17.58	49.16	210	103	Peak

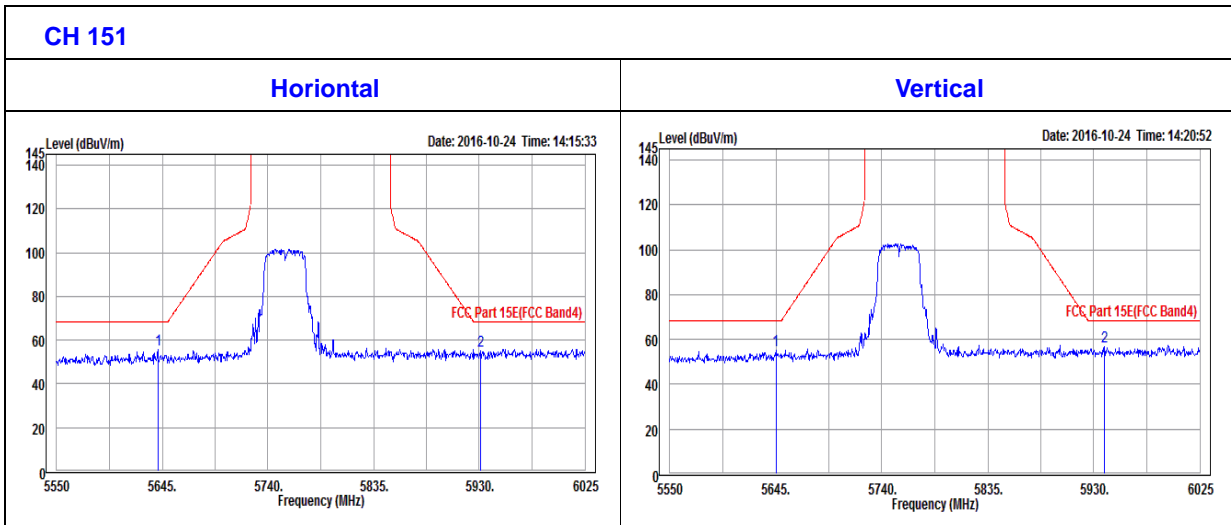



CHANNEL	TX Channel 159	DETECTOR FUNCTION	Peak (PK)
FREQUENCY RANGE	1GHz ~ 40GHz		Average (AV)

ANTENNA POLARITY & TEST DISTANCE: HORIZONTAL AT 3 M										
FREQ. (MHz)	EMISSION LEVEL (dBuV/m)	READ LEVEL (dBuV)	LIMIT (dBuV/m)	MARGIN (dB)	ANTENNA FACTOR (dB /m)	CABLE LOSS (dB)	PREAMP FACTOR (dB)	ANTENNA HEIGHT (cm)	TABLE ANGLE (Degree)	REMARK
5795	91.78	89.05			35.25	16.63	49.15	140	248	Average
5795	101.84	99.11			35.25	16.63	49.15	140	248	Peak
11590	48.77	38.64	54.00	-5.23	39.17	19.13	48.17	100	240	Average
11590	61.49	51.36	74.00	-12.51	39.17	19.13	48.17	100	240	Peak
ANTENNA POLARITY & TEST DISTANCE: VERTICAL AT 3 M										
FREQ. (MHz)	EMISSION LEVEL (dBuV/m)	READ LEVEL (dBuV)	LIMIT (dBuV/m)	MARGIN (dB)	ANTENNA FACTOR (dB /m)	CABLE LOSS (dB)	PREAMP FACTOR (dB)	ANTENNA HEIGHT (cm)	TABLE ANGLE (Degree)	REMARK
5795	92.23	89.50			35.25	16.63	49.15	145	80	Average
5795	103.19	100.46			35.25	16.63	49.15	145	80	Peak
11590	49.16	39.03	54.00	-4.84	39.17	19.13	48.17	100	96	Average
11590	62.02	51.89	74.00	-11.98	39.17	19.13	48.17	100	96	Peak

REMARKS:

- Emission Level = Read Level+ Antenna Factor + Cable Loss- Preamp Factor
Margin value = Emission level – Limit value.
- 5795MHz: Fundamental frequency.



OOBE DATA

802.11n (40MHZ)

ANTENNA POLARITY & TEST DISTANCE: HORIZONTAL AT 3 M										
FREQ. (MHz)	EMISSION LEVEL (dBuV/m)	READ LEVEL (dBuV)	LIMIT (dBuV/m)	MARGIN (dB)	ANTENNA FACTOR (dB /m)	CABLE LOSS (dB)	PREAMP FACTOR (dB)	ANTENNA HEIGHT (cm)	TABLE ANGLE (Degree)	REMARK
5635.975	53.42	51.89	68.3	-14.88	35.06	15.6	49.13	140	248	Peak
5935.225	56.16	52.35	68.3	-12.14	35.42	17.55	49.16	140	248	Peak
ANTENNA POLARITY & TEST DISTANCE: VERTICAL AT 3 M										
FREQ. (MHz)	EMISSION LEVEL (dBuV/m)	READ LEVEL (dBuV)	LIMIT (dBuV/m)	MARGIN (dB)	ANTENNA FACTOR (dB /m)	CABLE LOSS (dB)	PREAMP FACTOR (dB)	ANTENNA HEIGHT (cm)	TABLE ANGLE (Degree)	REMARK
5645.95	54.29	52.68	68.3	-14.01	35.08	15.66	49.13	144	80	Peak
5929.05	55.36	51.6	68.3	-12.94	35.41	17.51	49.16	144	80	Peak

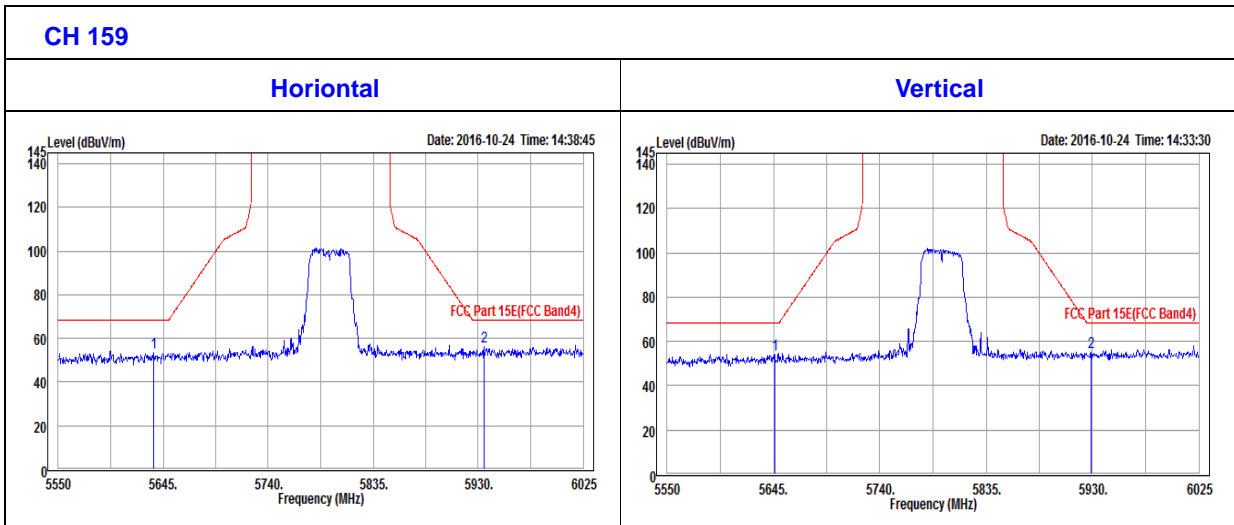



802.11ac (80MHz)

CHANNEL	TX Channel 155	DETECTOR FUNCTION	Peak (PK)
FREQUENCY RANGE	1GHz ~ 40GHz		Average (AV)

ANTENNA POLARITY & TEST DISTANCE: HORIZONTAL AT 3 M										
FREQ. (MHz)	EMISSION LEVEL (dBuV/m)	READ LEVEL (dBuV)	LIMIT (dBuV/m)	MARGIN (dB)	ANTENNA FACTOR (dB /m)	CABLE LOSS (dB)	PREAMP FACTOR (dB)	ANTENNA HEIGHT (cm)	TABLE ANGLE (Degree)	REMARK
5775	86.57	83.99			35.23	16.50	49.15	100	190	Average
5775	100.78	98.20			35.23	16.50	49.15	100	190	Peak
11550	49.33	39.25	54.00	-4.67	39.14	19.11	48.17	100	190	Average
11550	61.44	51.36	74.00	-12.56	39.14	19.11	48.17	100	190	Peak

ANTENNA POLARITY & TEST DISTANCE: VERTICAL AT 3 M										
FREQ. (MHz)	EMISSION LEVEL (dBuV/m)	READ LEVEL (dBuV)	LIMIT (dBuV/m)	MARGIN (dB)	ANTENNA FACTOR (dB /m)	CABLE LOSS (dB)	PREAMP FACTOR (dB)	ANTENNA HEIGHT (cm)	TABLE ANGLE (Degree)	REMARK
5775	87.02	84.44			35.23	16.50	49.15	120	130	Average
5775	101.14	98.56			35.23	16.50	49.15	120	130	Peak
11550	49.84	39.76	54.00	-4.16	39.14	19.11	48.17	120	130	Average
11550	61.10	51.02	74.00	-12.90	39.14	19.11	48.17	120	130	Peak

REMARKS:

- Emission Level = Read Level+ Antenna Factor + Cable Loss- Preamp Factor
Margin value = Emission level – Limit value.
- 5775MHz: Fundamental frequency.



OOBE DATA

802.11ac (80MHZ)

ANTENNA POLARITY & TEST DISTANCE: HORIZONTAL AT 3 M										
FREQ. (MHz)	EMISSION LEVEL (dBuV/m)	READ LEVEL (dBuV)	LIMIT (dBuV/m)	MARGIN (dB)	ANTENNA FACTOR (dB /m)	CABLE LOSS (dB)	PREAMP FACTOR (dB)	ANTENNA HEIGHT (cm)	TABLE ANGLE (Degree)	REMARK
5644.525	55.57	53.98	68.3	-12.73	35.07	15.65	49.13	100	190	Peak
5941.4	57.16	53.3	68.3	-11.14	35.43	17.59	49.16	100	190	Peak
ANTENNA POLARITY & TEST DISTANCE: VERTICAL AT 3 M										
FREQ. (MHz)	EMISSION LEVEL (dBuV/m)	READ LEVEL (dBuV)	LIMIT (dBuV/m)	MARGIN (dB)	ANTENNA FACTOR (dB /m)	CABLE LOSS (dB)	PREAMP FACTOR (dB)	ANTENNA HEIGHT (cm)	TABLE ANGLE (Degree)	REMARK
5645.95	52.89	51.28	68.3	-15.41	35.08	15.66	49.13	120	130	Peak
5930.95	54.92	51.14	68.3	-13.38	35.42	17.52	49.16	120	130	Peak

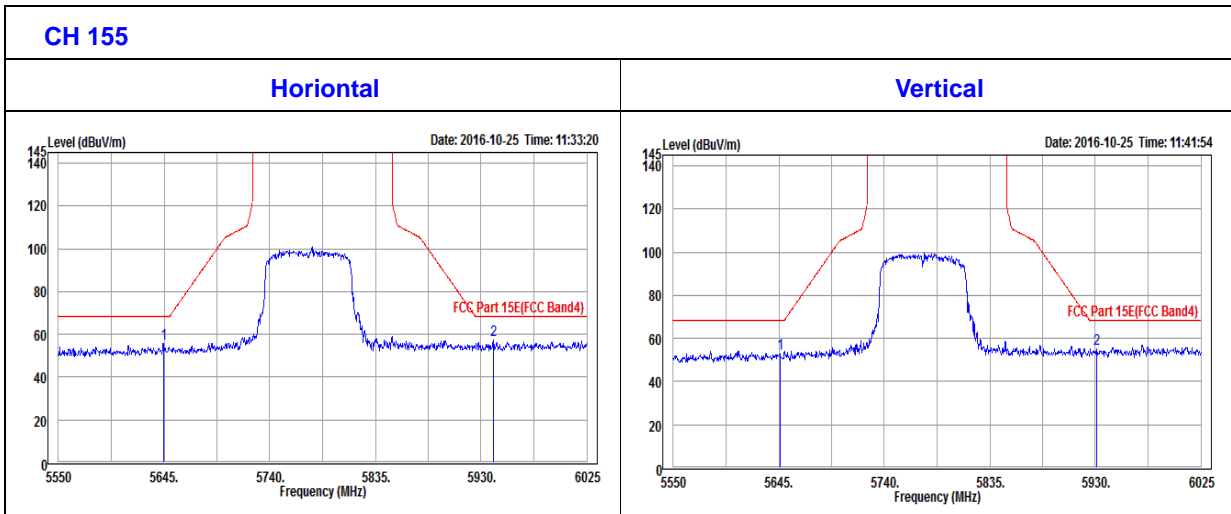



4.2 CONDUCTED EMISSION MEASUREMENT

4.2.1 LIMITS OF CONDUCTED EMISSION MEASUREMENT

FREQUENCY OF EMISSION (MHz)	CONDUCTED LIMIT (dBµV)	
	Quasi-peak	Average
0.15 ~ 0.5	66 to 56	56 to 46
0.5 ~ 5	56	46
5 ~ 30	60	50

- NOTE:**
1. The lower limit shall apply at the transition frequencies.
 2. The limit decreases in line with the logarithm of the frequency in the range of 0.15 to 0.50MHz.
 3. All emanations from a class A/B digital device or system, including any network of conductors and apparatus connected thereto, shall not exceed the level of field strengths specified above.

4.2.2 TEST INSTRUMENTS

Equipment	Manufacturer	Model No.	Serial No.	Last Cal.	Next Cal.
EMI Test Receiver	Rohde&Schwarz	ESCS30	100340	May 11,15	May 10,17
Artificial Mains Network	Rohde&Schwarz	ENV216	101173	Mar. 04,16	Mar. 03,17
Artificial Mains Network	Rohde&Schwarz	ESH3-Z5	100317	Apr. 05,16	Apr. 04,17
Voltage probe	SCHWARZBECK	TK 9421	TK 9421-176	Jan. 08,16	Jan. 07,17
Test software	ADT	ADT_Cond_V7.3.7	N/A	N/A	N/A

- NOTE:**
1. The test was performed in shielded room 553.
 2. The calibration interval of the above test instruments is 12 months. And the calibrations are traceable to CEPREI/CHINA, GRGT/CHINA and NIM/CHINA.

4.2.3 TEST PROCEDURES

- a. The EUT was placed 0.4 meters from the conducting wall of the shielded room with EUT being connected to the power mains through a line impedance stabilization network (LISN). Other support units were connected to the power mains through another LISN. The two LISNs provide 50 ohm/ 50uH of coupling impedance for the measuring instrument.
- b. Both lines of the power mains connected to the EUT were checked for maximum conducted interference.
- c. The frequency range from 150kHz to 30MHz was searched. Emission levels under (Limit - 20dB) was not recorded.

NOTE: All modes of operation were investigated and the worst-case emissions are reported.



4.2.4 DEVIATION FROM TEST STANDARD

No deviation.

4.2.5 TEST SETUP

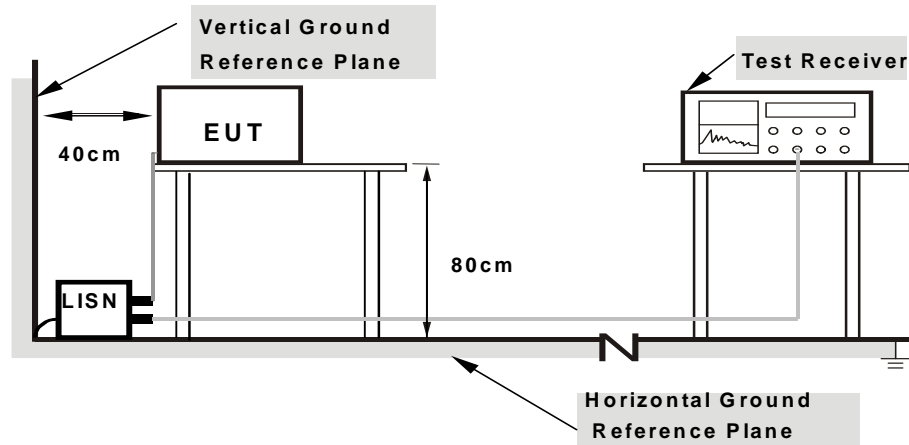

- Note: 1.Support units were connected to second LISN.
2.Both of LISNs (AMN) are 80 cm from EUT and at least 80
from other units and other metal planes**

For the actual test configuration, please refer to the attached file (Test Setup Photo).

4.2.6 EUT OPERATING CONDITIONS

Same as 4.1.6.



4.2.7 TEST RESULTS

CONDUCTED WORST-CASE DATA :

Frequency Range	150KHz ~ 30MHz	Detector Function & Resolution Bandwidth	Quasi-Peak (QP) / Average (AV), 9 kHz
Input Power	120Vac, 60Hz	Environmental Conditions	24deg. C, 55RH
Tested By	Eric	TEST DATE	2016/10/23

Frequency (MHz)	QuasiPeak (dB μ V)	CAverage (dB μ V)	Limit (dB μ V)	Margin (dB)	Line	Filter	Corr. (dB)
0.412000	---	32.03	47.61	15.58	L	ON	9.7
0.412000	43.52	---	57.61	14.09	L	ON	9.7
0.492000	---	27.33	46.13	18.80	L	ON	9.7
0.492000	39.07	---	56.13	17.06	L	ON	9.7
4.608000	---	28.36	46.00	17.64	L	ON	9.7
4.608000	38.67	---	56.00	17.33	L	ON	9.7
10.372000	---	29.23	50.00	20.77	L	ON	9.9
10.372000	41.67	---	60.00	18.33	L	ON	9.9
14.108000	---	32.48	50.00	17.52	L	ON	9.9
14.108000	45.55	---	60.00	14.45	L	ON	9.9
19.524000	---	16.39	50.00	33.61	L	ON	9.9
19.524000	31.61	---	60.00	28.39	L	ON	9.9

- REMARKS:**
1. Q.P. and AV. are abbreviations of quasi-peak and average individually.
 2. "-": The Quasi-peak reading value also meets average limit and measurement with the average detector is unnecessary.
 3. The emission levels of other frequencies were very low against the limit.
 4. Margin value = Emission level - Limit value
 5. Correction factor = Insertion loss + Cable loss
 6. Emission Level = Correction Factor + Reading Value.

Full Spectrum

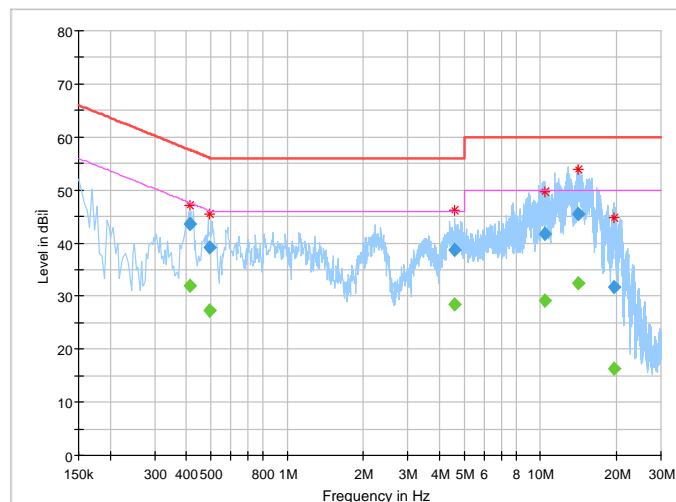



Frequency Range	150KHz ~ 30MHz	Detector Function & Resolution Bandwidth	Quasi-Peak (QP) / Average (AV), 9 kHz
Input Power	120Vac, 60Hz	Environmental Conditions	24deg. C, 55RH
Tested By	Eric	TEST DATE	2016/10/23

Frequency (MHz)	QuasiPeak (dB μ V)	CAverage (dB μ V)	Limit (dB μ V)	Margin (dB)	Line	Filter	Corr. (dB)
0.476000	---	31.37	46.41	15.04	N	ON	10.1
0.476000	41.99	---	56.41	14.42	N	ON	10.1
1.072000	---	23.93	46.00	22.07	N	ON	9.9
1.072000	35.54	---	56.00	20.46	N	ON	9.9
2.292000	---	21.42	46.00	24.58	N	ON	9.8
2.292000	32.60	---	56.00	23.40	N	ON	9.8
4.372000	---	24.65	46.00	21.35	N	ON	9.8
4.372000	36.10	---	56.00	19.90	N	ON	9.8
10.032000	---	27.27	50.00	22.73	N	ON	9.9
10.032000	38.04	---	60.00	21.96	N	ON	9.9
10.440000	---	25.56	50.00	24.44	N	ON	9.9
10.440000	35.41	---	60.00	24.59	N	ON	9.9

- REMARKS:**
1. Q.P. and AV. are abbreviations of quasi-peak and average individually.
 2. "-": The Quasi-peak reading value also meets average limit and measurement with the average detector is unnecessary.
 3. The emission levels of other frequencies were very low against the limit.
 4. Margin value = Emission level - Limit value
 5. Correction factor = Insertion loss + Cable loss
 6. Emission Level = Correction Factor + Reading Value.

Full Spectrum

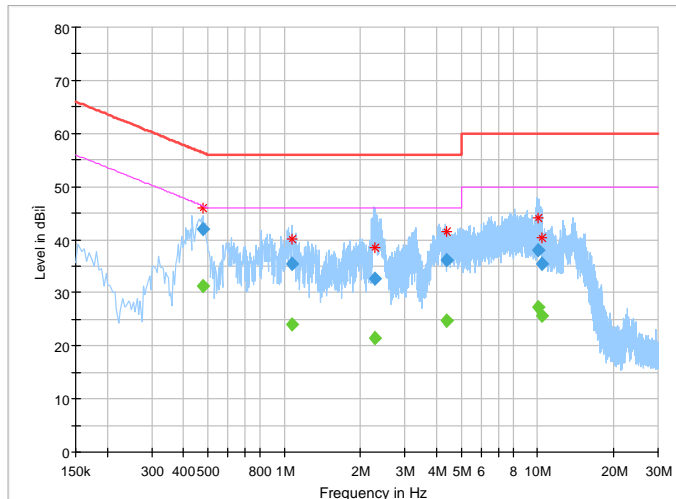



4.3 MAXIMUM CONDUCTED OUTPUT POWER MEASUREMENT

4.3.1 LIMITS OF MAXIMUM CONDUCTED OUTPUT POWER MEASUREMENT

Operation Band	EUT Category		LIMIT
U-NII-1		Outdoor Access Point	1 Watt (30 dBm) (Max. e.i.r.p \leq 125mW(21 dBm) at any elevation angle above 30 degrees as measured from the horizon)
		Fixed point-to-point Access Point	1 Watt (30 dBm)
		Indoor Access Point	1 Watt (30 dBm)
	√	Client devices	250mW (24 dBm)
U-NII-2A	√		250mW (24 dBm) or 11 dBm+10 log B*
U-NII-2C	√		250mW (24 dBm) or 11 dBm+10 log B*
U-NII-3	√		1 Watt (30 dBm)

NOTE: Where B is the 26dB emission bandwidth in MHz.

4.3.2 TEST SETUP

FOR POWER OUTPUT MEASUREMENT

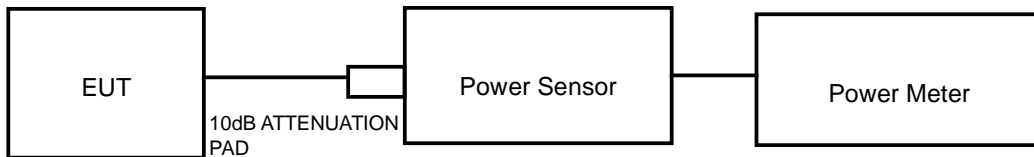

FOR 26dB BANDWIDTH

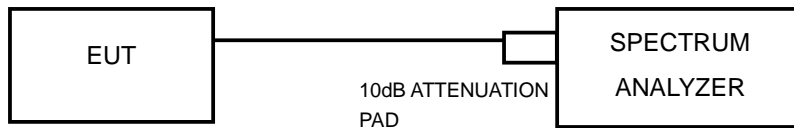



4.3.3 TEST INSTRUMENTS

Refer to section 4.1.3 to get information of above instrument.

4.3.4 TEST PROCEDURE

FOR POWER MEASUREMENT

Method PM is used to perform output power measurement, trigger and gating function of wide band power meter is enabled to measure max output power of TX on burst. Duty factor is not added to measured value.

FOR 99 PERCENT OCCUPIED BANDWIDTH

The following procedure shall be used for measuring (99 %) power bandwidth:

1. Set center frequency to the nominal EUT channel center frequency.
2. Set span = 1.5 times to 5.0 times the OBW.
3. Set RBW = 1 % to 5 % of the OBW
4. Set VBW $\geq 3 \cdot$ RBW
5. Video averaging is not permitted. Where practical, a sample detection and single sweep mode shall be used. Otherwise, peak detection and max hold mode (until the trace stabilizes) shall be used.
6. Use the 99 % power bandwidth function of the instrument (if available).
7. If the instrument does not have a 99 % power bandwidth function, the trace data points are recovered and directly summed in power units. The recovered amplitude data points, beginning at the lowest frequency, are placed in a running sum until 0.5 % of the total is reached; that frequency is recorded as the lower frequency. The process is repeated until 99.5 % of the total is reached; that frequency is recorded as the upper frequency. The 99% occupied bandwidth is the difference between these two frequencies.



FOR 26dB BANDWIDTH

- 1) Set RBW = approximately 1% of the emission bandwidth.
- 2) Set the VBW > RBW.
- 3) Detector = Peak.
- 4) Trace mode = max hold.
- 5) Measure the maximum width of the emission that is 26 dB down from the peak of the emission. Compare this with the RBW setting of the analyzer. Readjust RBW and repeat measurement as needed until the RBW/EBW ratio is approximately 1%.

FOR 6dB BANDWIDTH

1. Set RBW = 100 kHz.
2. Set the video bandwidth (VBW) ≥ 3 RBW.
3. Detector = Peak.
4. Trace mode = max hold.
5. Sweep = auto couple.
6. Allow the trace to stabilize.
7. Measure the maximum width of the emission that is constrained by the frequencies associated with the two outermost amplitude points (upper and lower frequencies) that are attenuated by 6 dB relative to the maximum level measured in the fundamental emission.

4.3.5 DEVIATION FROM TEST STANDARD

No deviation.

4.3.6 EUT OPERATING CONDITIONS

The software provided by client to enable the EUT under transmission condition continuously at specific channel frequencies individually.



4.3.7 TEST RESULTS

OUTPUT POWER:

802.11a

CHANNEL	CHANNEL FREQUENCY (MHz)	AVERAGE POWER (dBm)	AVERAGE POWER ((mW)	POWER LIMIT (dBm)	PASS/FAIL
36	5180	14.90	30.903	24	PASS
40	5200	14.57	28.642	24	PASS
48	5240	14.39	27.479	24	PASS
52	5260	14.10	25.704	24	PASS
60	5300	14.08	25.586	24	PASS
64	5320	14.13	25.882	24	PASS
100	5500	14.65	29.174	24	PASS
116	5580	13.96	24.889	24	PASS
132	5660	14.22	26.424	24	PASS
140	5700	14.06	25.468	24	PASS
149	5745	13.92	24.660	30	PASS
157	5785	13.90	24.547	30	PASS
165	5825	13.47	22.233	30	PASS

802.11n (20MHz)

CHANNEL	CHANNEL FREQUENCY (MHz)	AVERAGE POWER (dBm)	AVERAGE POWER ((mW)	POWER LIMIT (dBm)	PASS/FAIL
36	5180	14.57	28.642	24	PASS
40	5200	14.49	28.119	24	PASS
48	5240	14.43	27.733	24	PASS
52	5260	14.54	28.445	24	PASS
60	5300	14.40	27.542	24	PASS
64	5320	14.18	26.182	24	PASS
100	5500	14.17	26.122	24	PASS
116	5580	13.93	24.717	24	PASS
132	5660	14.21	26.363	24	PASS
140	5700	13.91	24.604	24	PASS
149	5745	13.72	23.550	30	PASS
157	5785	13.66	23.227	30	PASS
165	5825	13.67	23.281	30	PASS



802.11n (40MHz)

CHANNEL	CHANNEL FREQUENCY (MHz)	AVERAGE POWER (dBm)	AVERAGE POWER ((mW)	POWER LIMIT (dBm)	PASS/FAIL
38	5190	13.61	22.961	24	PASS
46	5230	13.43	22.029	24	PASS
54	5270	13.63	23.067	24	PASS
62	5310	13.44	22.080	24	PASS
102	5510	13.57	22.751	24	PASS
110	5550	13.35	21.627	24	PASS
134	5670	13.18	20.797	24	PASS
151	5755	12.76	18.880	30	PASS
165	5825	12.78	18.967	30	PASS

802.11ac (80MHz)

CHANNEL	CHANNEL FREQUENCY (MHz)	AVERAGE POWER (dBm)	AVERAGE POWER ((mW)	POWER LIMIT (dBm)	PASS/FAIL
42	5210	14.24	26.546	24	PASS
58	5290	14.21	26.363	24	PASS
106	5530	14.60	28.840	24	PASS
155	5775	14.39	27.479	30	PASS



99% OCCUPIED BANDWIDTH & 26dB BANDWIDTH/6dB BANDWIDTH:

802.11a

CHANNEL	CHANNEL FREQUENCY (MHz)	99% OCCUPIED BANDWIDTH	26dB BANDWIDTH (MHz)	PASS/FAIL
36	5180	16.86	22.43	PASS
40	5200	16.86	22.30	PASS
48	5240	16.86	22.14	PASS
52	5260	16.92	22.58	PASS
60	5300	16.86	22.18	PASS
64	5320	16.98	22.13	PASS
100	5500	16.80	22.29	PASS
116	5580	16.98	22.24	PASS
132	5660	16.92	22.22	PASS
140	5700	16.92	22.43	PASS
CHANNEL	CHANNEL FREQUENCY (MHz)	99% OCCUPIED BANDWIDTH	6dB BANDWIDTH (MHz)	PASS/FAIL
149	5745	16.92	16.36	PASS
157	5785	16.86	16.36	PASS
165	5825	16.92	16.36	PASS



802.11n (20MHz)

CHANNEL	CHANNEL FREQUENCY (MHz)	99% OCCUPIED BANDWIDTH	26dB BANDWIDTH (MHz)	PASS/FAIL
36	5180	17.94	23.02	PASS
40	5200	18.00	22.68	PASS
48	5240	17.94	22.94	PASS
52	5260	18.00	22.48	PASS
60	5300	17.94	22.67	PASS
64	5320	17.94	22.70	PASS
100	5500	18.00	22.98	PASS
116	5580	18.00	22.43	PASS
132	5660	17.94	22.72	PASS
140	5700	18.00	22.61	PASS
CHANNEL	CHANNEL FREQUENCY (MHz)	99% OCCUPIED BANDWIDTH	6dB BANDWIDTH (MHz)	PASS/FAIL
149	5745	18.00	17.59	PASS
157	5785	18.00	17.59	PASS
165	5825	17.94	17.60	PASS



802.11n (40MHz)

CHANNEL	CHANNEL FREQUENCY (MHz)	99% OCCUPIED BANDWIDTH	26dB BANDWIDTH (MHz)	PASS/FAIL
38	5190	36.36	45.76	PASS
46	5230	36.36	45.16	PASS
54	5270	36.42	45.85	PASS
62	5310	36.42	45.29	PASS
102	5510	36.36	45.46	PASS
110	5550	36.42	45.57	PASS
134	5670	36.36	45.01	PASS
CHANNEL	CHANNEL FREQUENCY (MHz)	99% OCCUPIED BANDWIDTH	6dB BANDWIDTH (MHz)	PASS/FAIL
151	5755	36.36	35.38	PASS
159	5795	36.30	35.17	PASS

802.11ac (80MHz)

CHANNEL	CHANNEL FREQUENCY (MHz)	99% OCCUPIED BANDWIDTH	26dB BANDWIDTH (MHz)	PASS/FAIL
42	5210	75.00	84.05	PASS
58	5290	74.64	84.10	PASS
106	5530	74.64	84.34	PASS
CHANNEL	CHANNEL FREQUENCY (MHz)	99% OCCUPIED BANDWIDTH	6dB BANDWIDTH (MHz)	PASS/FAIL
155	5775	74.64	75.12	PASS



BUREAU VERITAS

Test Report No.: RF161008W001-6

For U-NII-1:

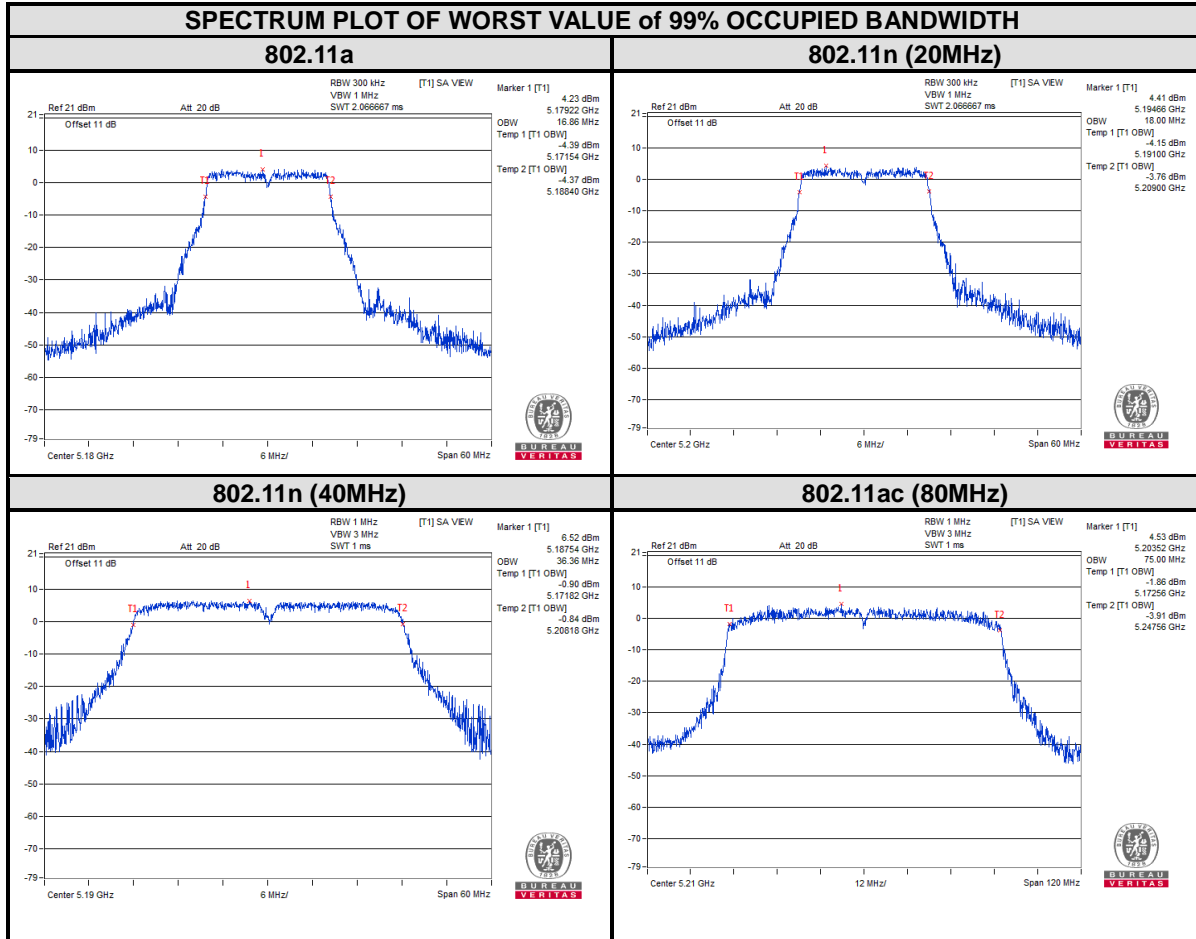

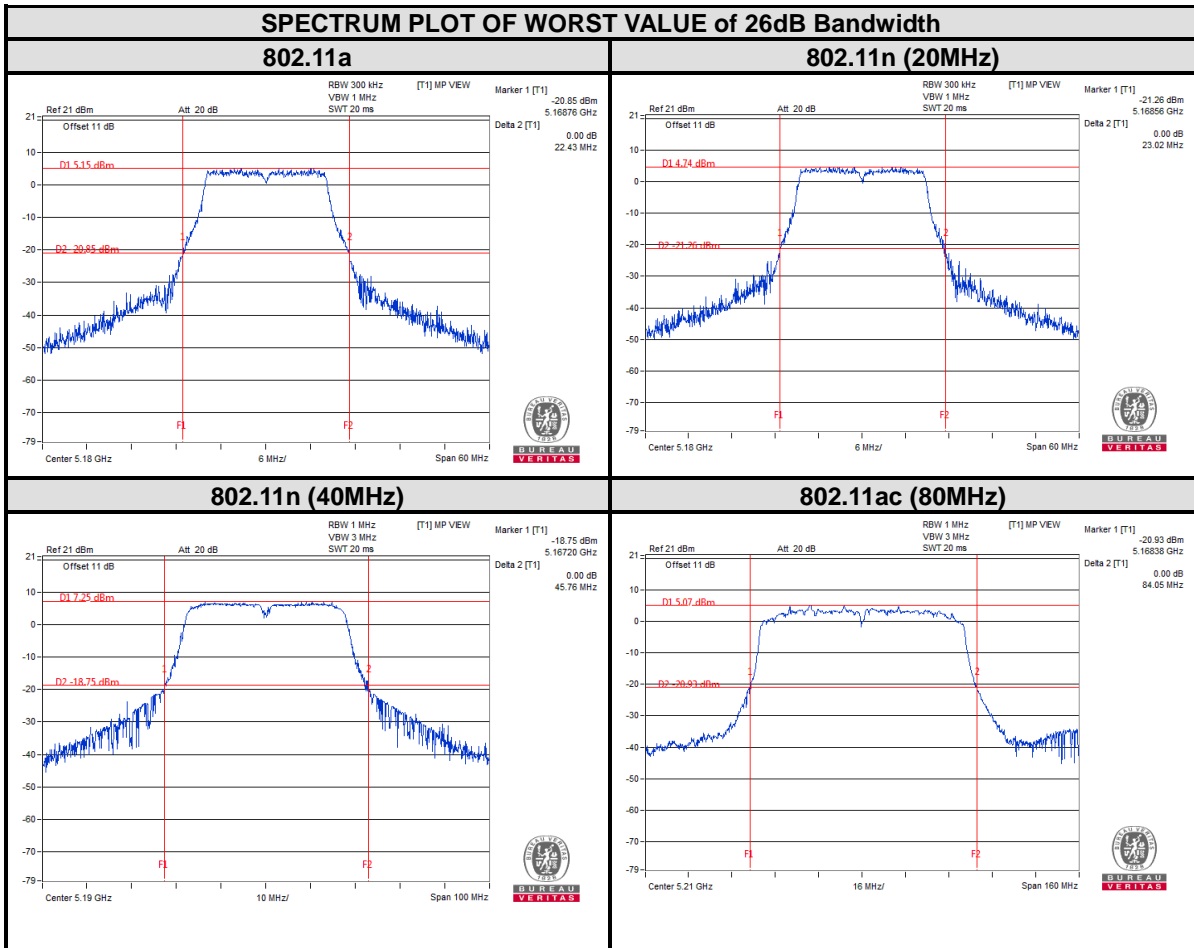



BUREAU VERITAS

Test Report No.: RF161008W001-6

For U-NII-2A:

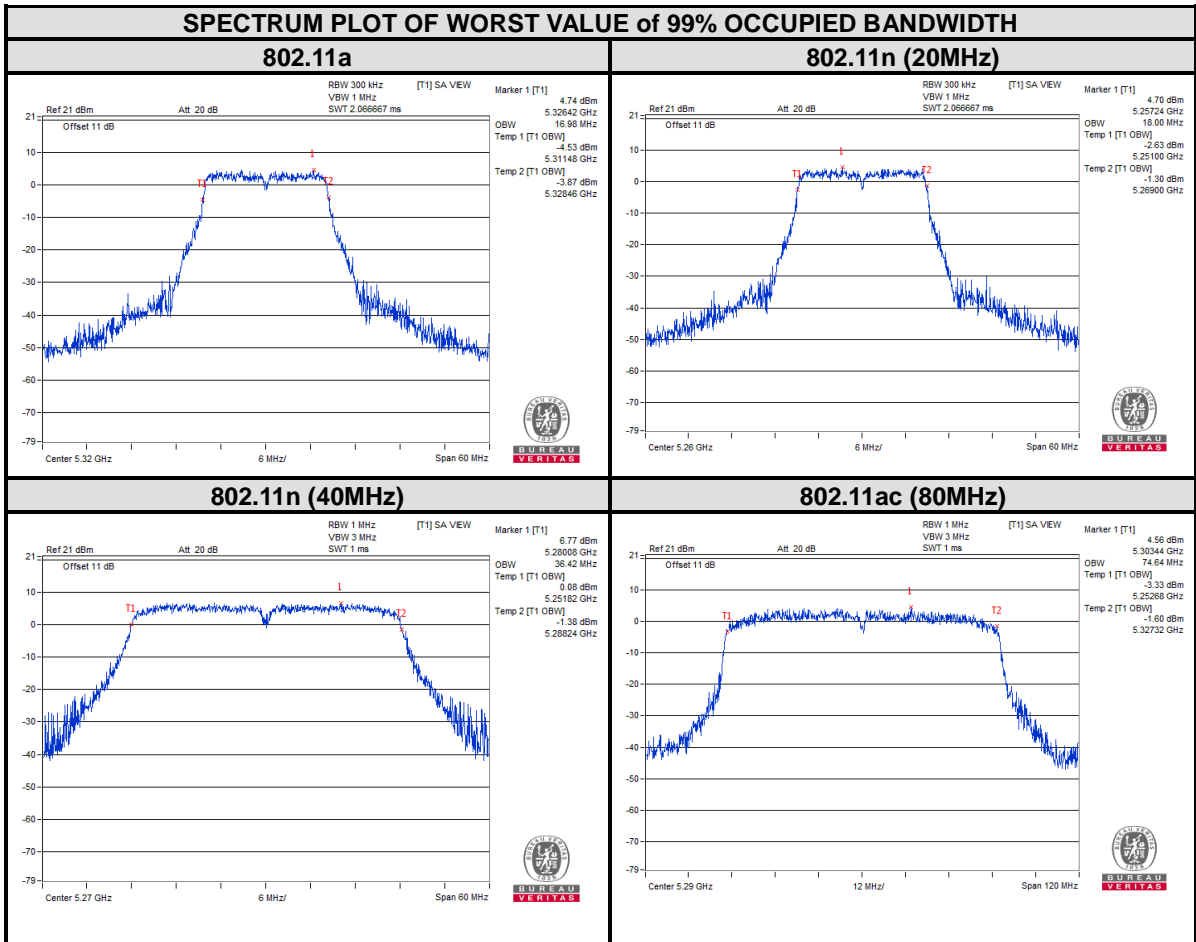



BUREAU VERITAS

Test Report No.: RF161008W001-6

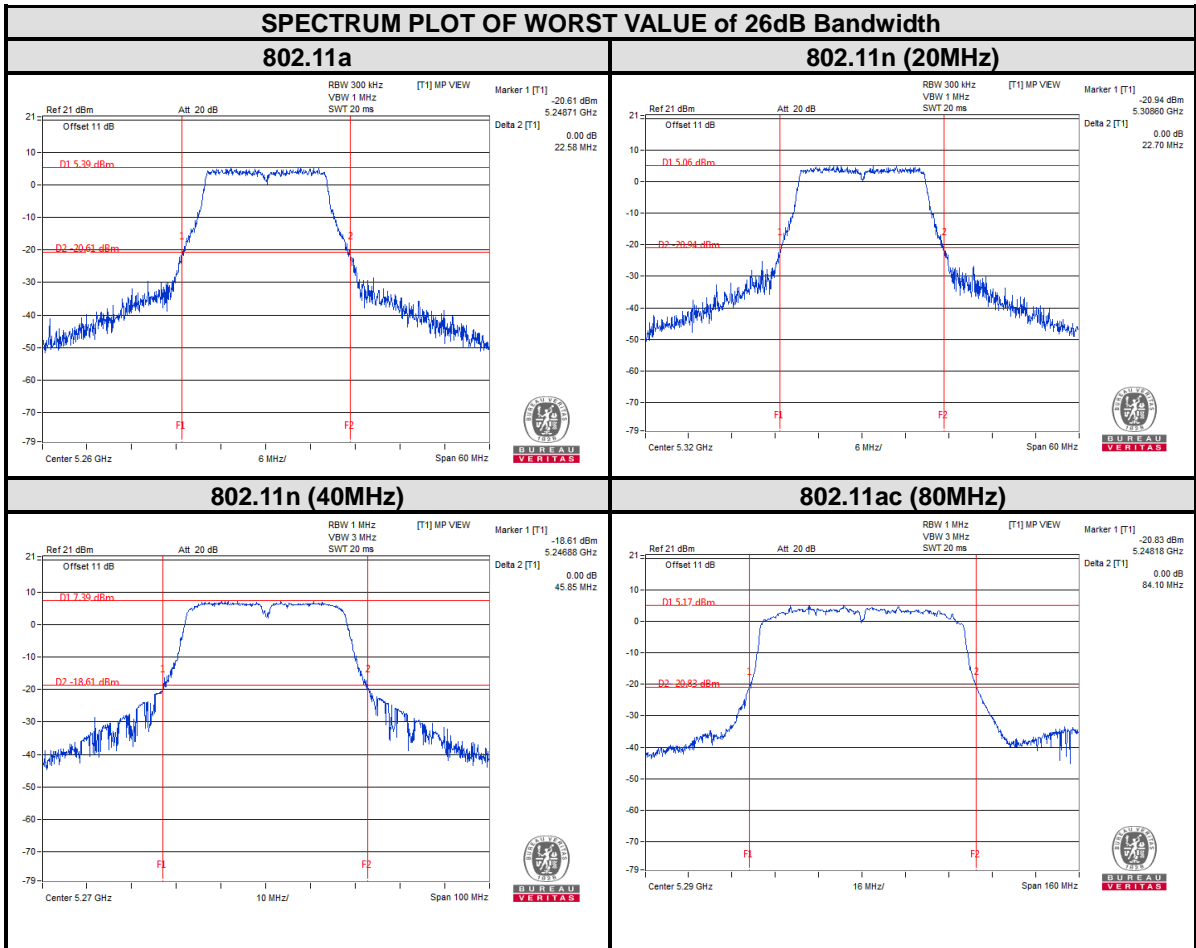

Bureau Veritas Shenzhen Co., Ltd.
Dongguan Branch

No. 34, Chenwulu Section, Guantai Rd., Houjie
Town, Dongguan City, Guangdong 523942, China

Tel: +86 769 8593 5656
Fax: +86 769 8593 1080
Email: customerservice.dg@cn.bureauveritas.com



BUREAU VERITAS

Test Report No.: RF161008W001-6

For U-NII-2C:

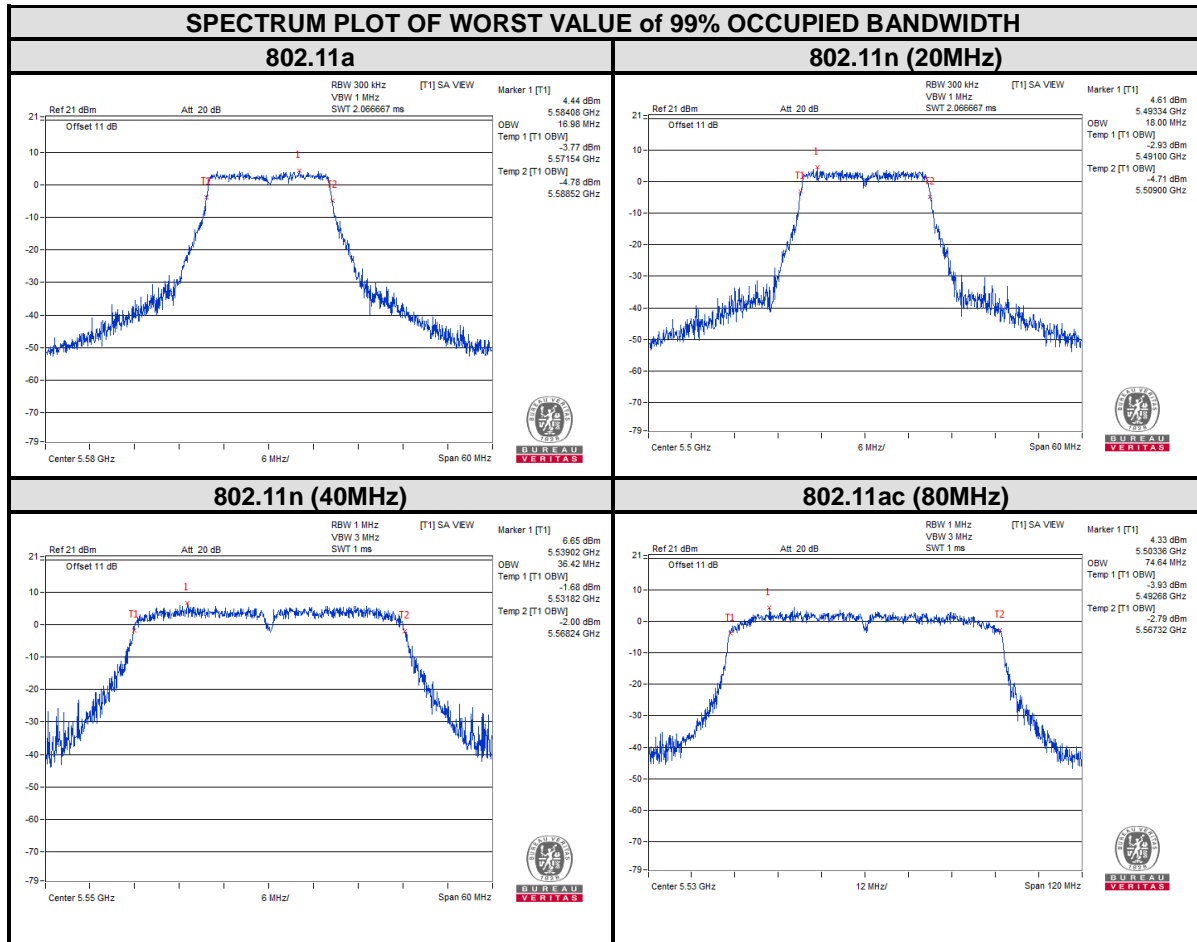



BUREAU
VERITAS

Test Report No.: RF161008W001-6

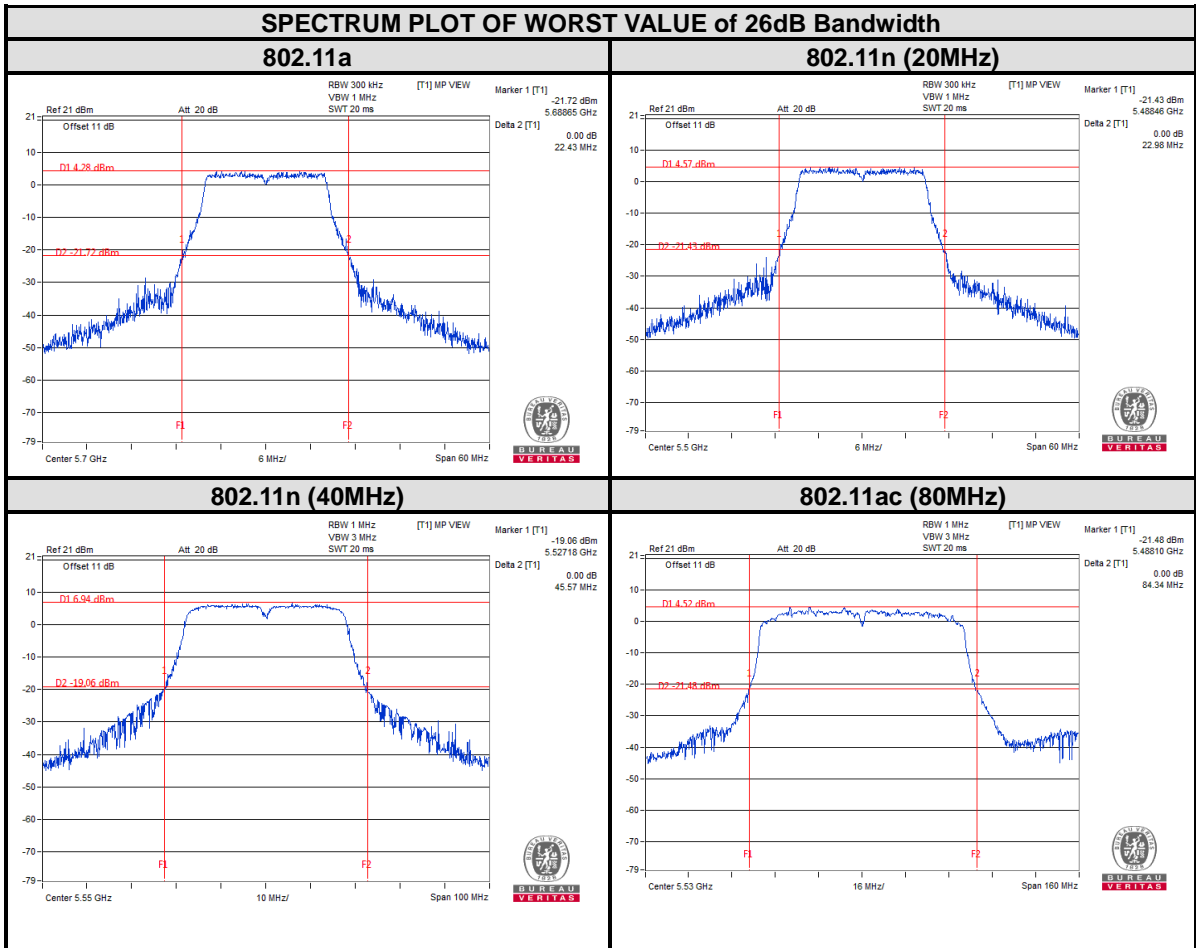



BUREAU VERITAS

Test Report No.: RF161008W001-6

For U-NII-3:

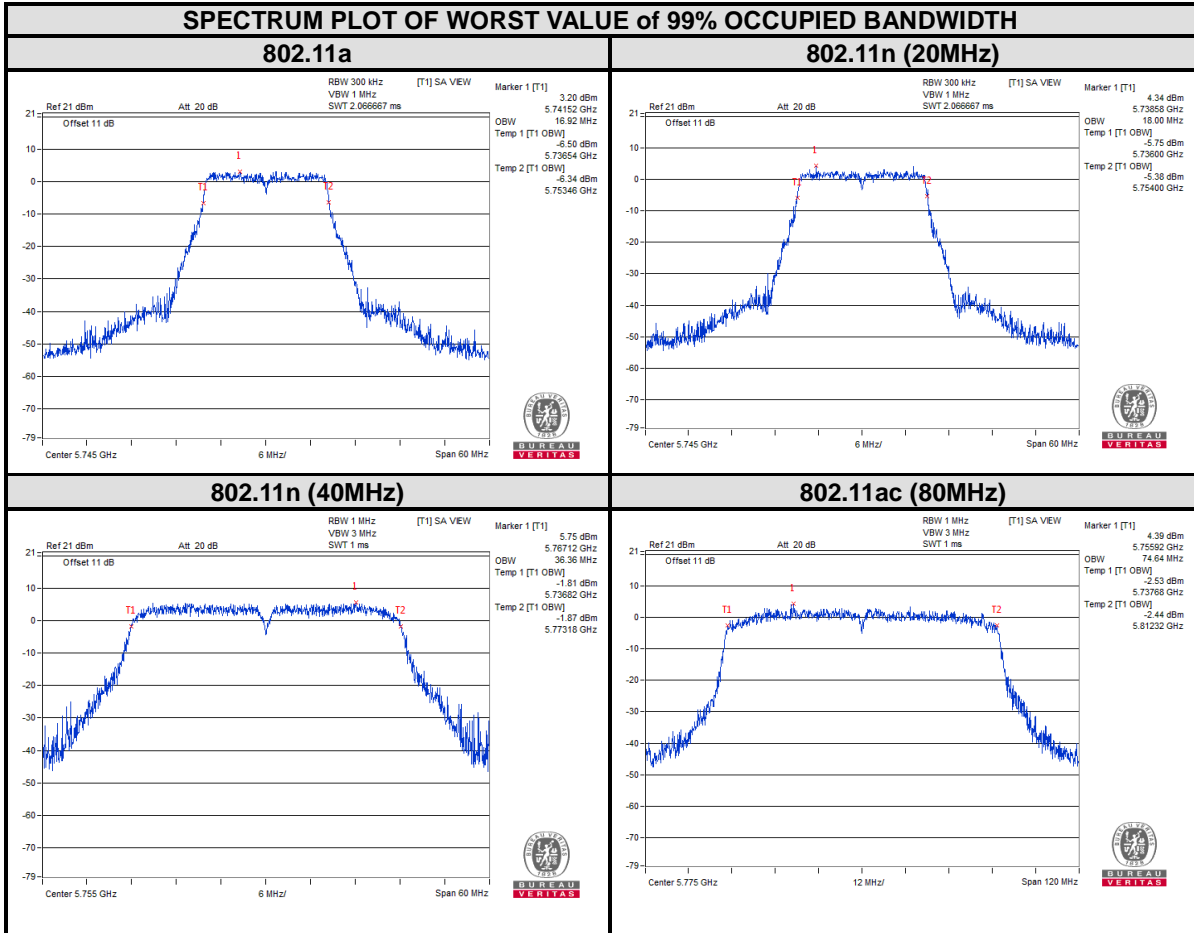



BUREAU VERITAS

Test Report No.: RF161008W001-6

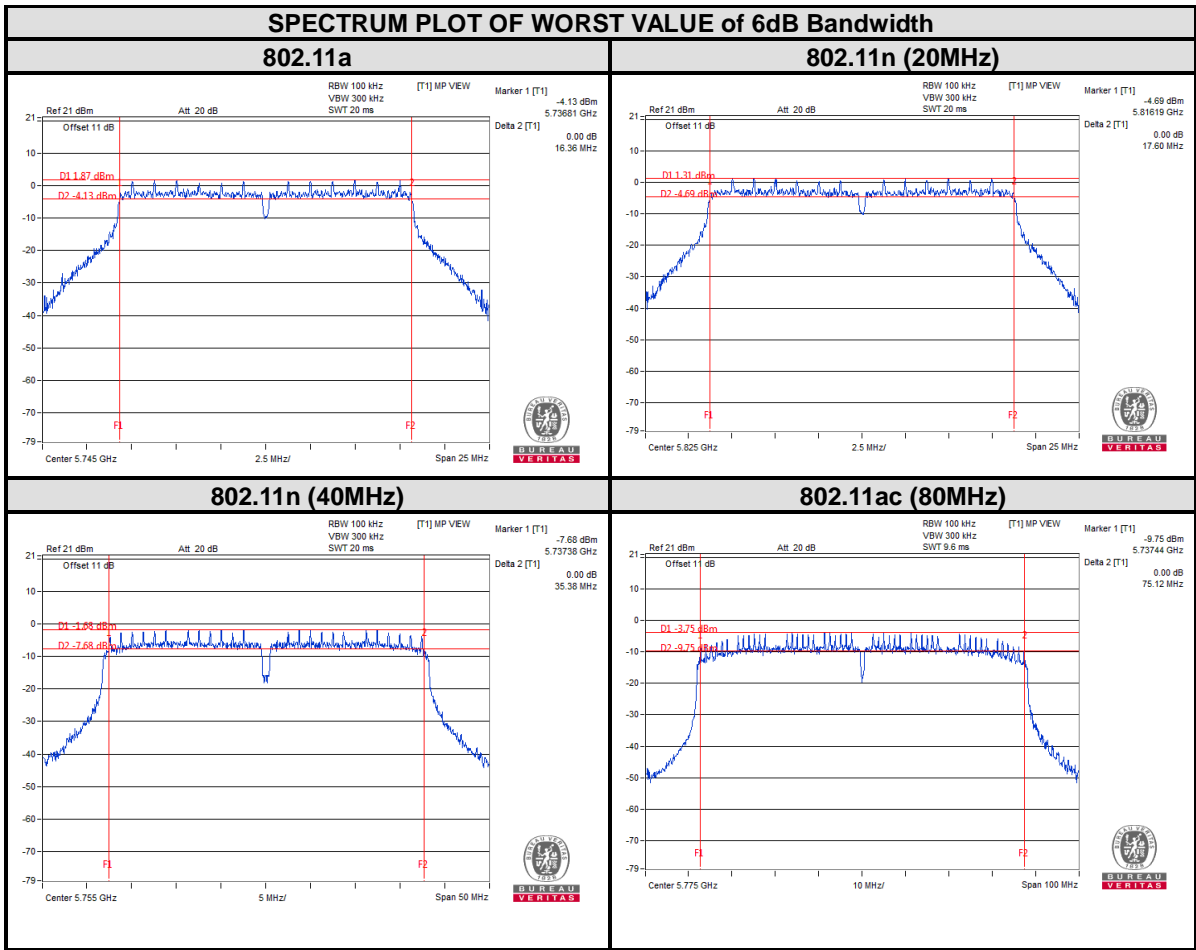

Bureau Veritas Shenzhen Co., Ltd.
Dongguan Branch

No. 34, Chenwulu Section, Guantai Rd., Houjie
Town, Dongguan City, Guangdong 523942, China

Tel: +86 769 8593 5656
Fax: +86 769 8593 1080
Email: customerservice.dg@cn.bureauveritas.com



4.4 PEAK POWER SPECTRAL DENSITY MEASUREMENT

4.4.1 LIMITS OF PEAK POWER SPECTRAL DENSITY MEASUREMENT

Operation Band	EUT Category		LIMIT
U-NII-1		Outdoor Access Point	17dBm/ MHz
		Fixed point-to-point Access Point	
		Indoor Access Point	
	√	Client devices	11dBm/ MHz
U-NII-2A	√		11dBm/ MHz
U-NII-2C	√		11dBm/ MHz
U-NII-3	√		30dBm/ 500kHz

4.4.2 TEST SETUP

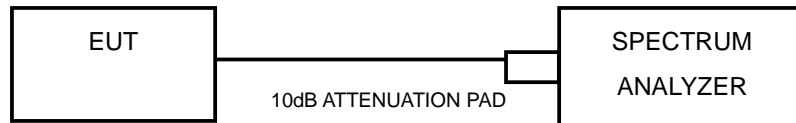

4.4.3 TEST INSTRUMENTS

Refer to section 4.1.3 to get information of above instrument.



4.4.4 TEST PROCEDURES

Using method SA-1

- 1) Set span to encompass the entire emission bandwidth (EBW) of the signal.
- 2) Set RBW = 30 KHz, Set VBW \geq 1 MHz, Detector = RMS
- 3) Set Channel power measure = 1MHz
- 4) Sweep time = auto, trigger set to "free run".
- 5) Trace average at least 100 traces in power averaging mode.
- 6) Record the max value

4.4.5 DEVIATION FROM TEST STANDARD

No deviation.

4.4.6 EUT OPERATING CONDITIONS

Same as 4.1.6.



4.4.7 TEST RESULTS

For U-NII-1, U-NII-2A & U-NII-2C:

802.11a

CHANNEL	FREQUENCY (MHz)	PSD w/o Duty Factor (dBm/MHz)	Duty Factor	PSD with Duty Factor (dBm/MHz)	MAXIMUM LIMIT (dBm/MHz)	PASS/FAIL
36	5180	6.73	0.66	7.39	11	PASS
40	5200	7.54	0.66	8.20	11	PASS
48	5240	7.45	0.66	8.11	11	PASS
52	5260	7.15	0.66	7.81	11	PASS
60	5300	7.69	0.66	8.35	11	PASS
64	5320	8.15	0.66	8.81	11	PASS
100	5500	7.21	0.66	7.87	11	PASS
116	5580	6.51	0.66	7.17	11	PASS
132	5660	7.14	0.66	7.80	11	PASS
140	5700	8.30	0.66	8.96	11	PASS

802.11n (20MHz)

CHANNEL	FREQUENCY (MHz)	PSD w/o Duty Factor (dBm/MHz)	Duty Factor	PSD with Duty Factor (dBm/MHz)	MAXIMUM LIMIT (dBm/MHz)	PASS/FAIL
36	5180	7.06	0.64	7.70	11	PASS
40	5200	7.17	0.64	7.81	11	PASS
48	5240	7.88	0.64	8.52	11	PASS
52	5260	8.56	0.64	9.20	11	PASS
60	5300	7.38	0.64	8.02	11	PASS
64	5320	7.87	0.64	8.51	11	PASS
100	5500	7.15	0.64	7.79	11	PASS
116	5580	7.00	0.64	7.64	11	PASS
132	5660	6.35	0.64	6.99	11	PASS
140	5700	7.48	0.64	8.12	11	PASS



802.11n (40MHz)

CHANNEL	FREQUENCY (MHz)	PSD w/o Duty Factor (dBm/MHz)	Duty Factor	PSD with Duty Factor (dBm/MHz)	MAXIMUM LIMIT (dBm/MHz)	PASS/FAIL
38	5190	3.65	1.22	4.87	11	PASS
46	5230	3.44	1.22	4.66	11	PASS
54	5270	4.28	1.22	5.5	11	PASS
62	5310	4.13	1.22	5.35	11	PASS
102	5510	3.90	1.22	5.12	11	PASS
110	5550	3.20	1.22	4.42	11	PASS
134	5670	2.52	1.22	3.74	11	PASS

802.11ac (80MHz)

CHANNEL	FREQUENCY (MHz)	PSD w/o Duty Factor (dBm/MHz)	Duty Factor	PSD with Duty Factor (dBm/MHz)	MAXIMUM LIMIT (dBm/MHz)	PASS/FAIL
42	5210	2.03	2.68	4.71	11	PASS
58	5290	1.83	2.68	4.51	11	PASS
106	5530	1.27	2.68	3.95	11	PASS



For U-NII-3:

802.11a

CHANNEL	FREQUENCY (MHz)	PSD w/o Duty Factor (dBm/500kHz)	Duty Factor	PSD with Duty Factor (dBm/500kHz)	LIMIT (dBm/500kHz)	PASS /FAIL
149	5745	8.22	0.66	8.88	30	PASS
157	5785	7.57	0.66	8.23	30	PASS
165	5825	7.70	0.66	8.36	30	PASS

802.11n (20MHz)

CHANNEL	FREQUENCY (MHz)	PSD w/o Duty Factor (dBm/500kHz)	Duty Factor	PSD with Duty Factor (dBm/500kHz)	LIMIT (dBm/500kHz)	PASS /FAIL
149	5745	7.84	0.64	8.48	30	PASS
157	5785	7.82	0.64	8.46	30	PASS
165	5825	7.68	0.64	8.32	30	PASS

802.11n (40MHz)

CHANNEL	FREQUENCY (MHz)	PSD w/o Duty Factor (dBm/500kHz)	Duty Factor	PSD with Duty Factor (dBm/500kHz)	LIMIT (dBm/500kHz)	PASS /FAIL
151	5755	4.39	1.22	5.61	30	PASS
159	5795	4.10	1.22	5.32	30	PASS

802.11ac (80MHz)

CHANNEL	FREQUENCY (MHz)	PSD w/o Duty Factor (dBm/500kHz)	Duty Factor	PSD with Duty Factor (dBm/500kHz)	LIMIT (dBm/500kHz)	PASS /FAIL
155	5775	1.54	2.68	4.22	30	PASS



**BUREAU
VERITAS**

Test Report No.: RF161008W001-6

For 5180~5240MHz

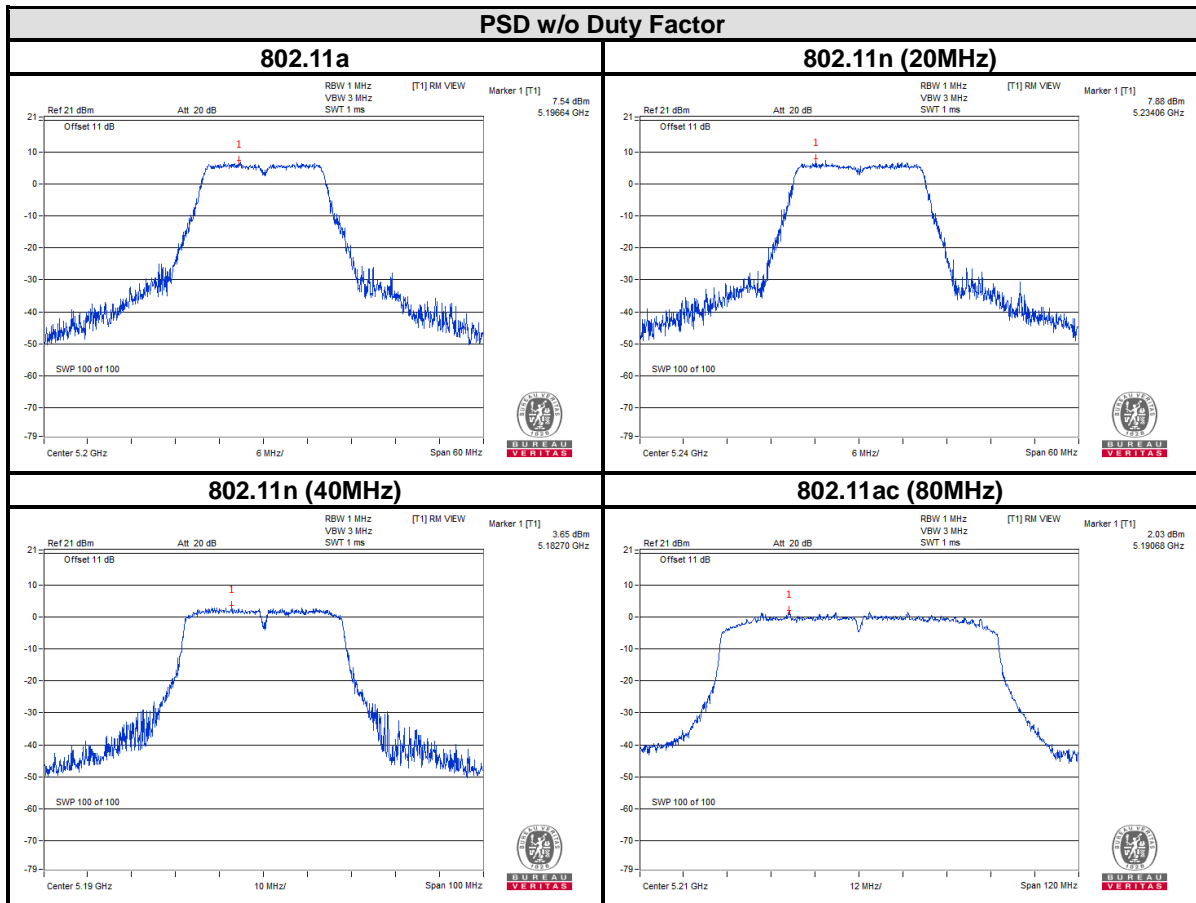

Bureau Veritas Shenzhen Co., Ltd.
Dongguan Branch

No. 34, Chenwulu Section, Guantai Rd., Houjie
Town, Dongguan City, Guangdong 523942, China

Tel: +86 769 8593 5656
Fax: +86 769 8593 1080
Email: customerservice.dg@cn.bureauveritas.com



**BUREAU
VERITAS**

Test Report No.: RF161008W001-6

For 5260~5320MHz

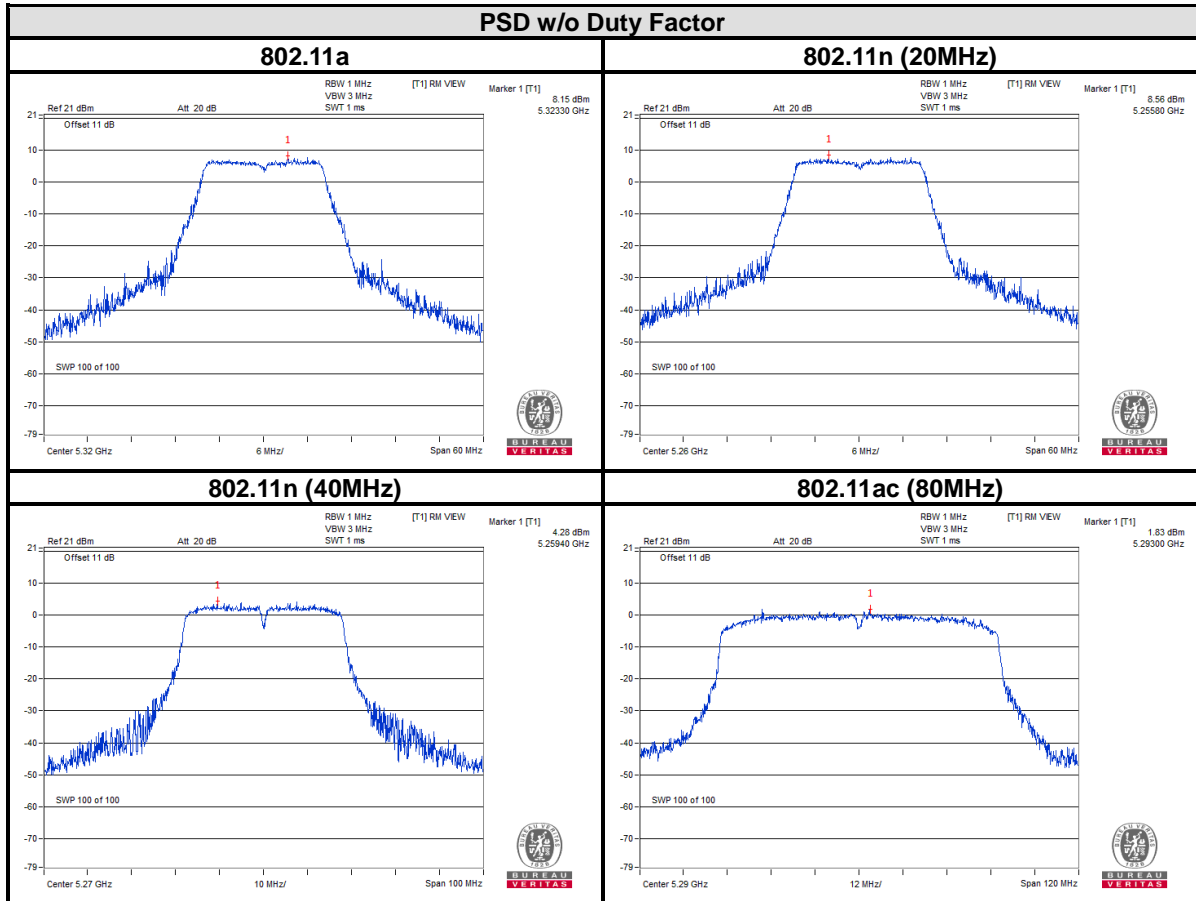



**BUREAU
VERITAS**

Test Report No.: RF161008W001-6

For 5500~5700MHz

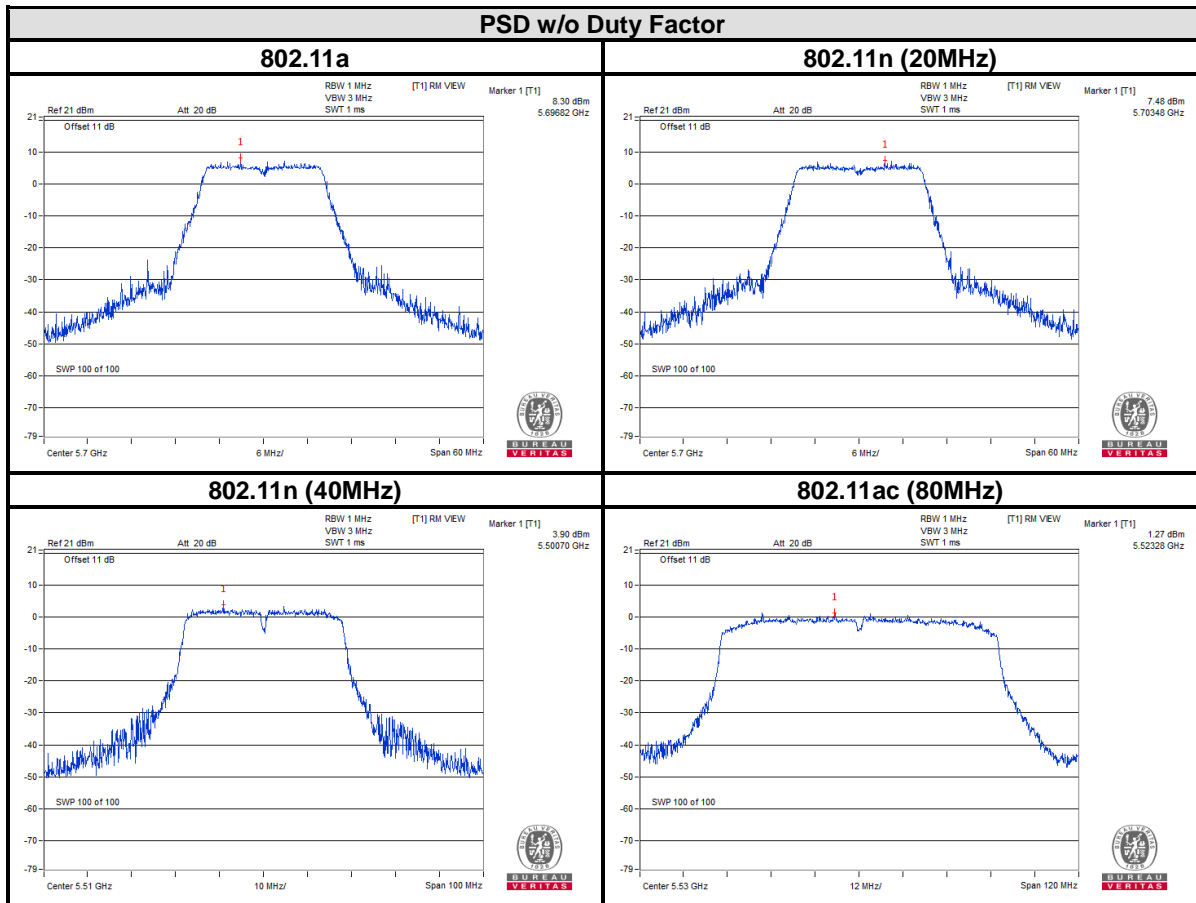



For 5745~5825MHz

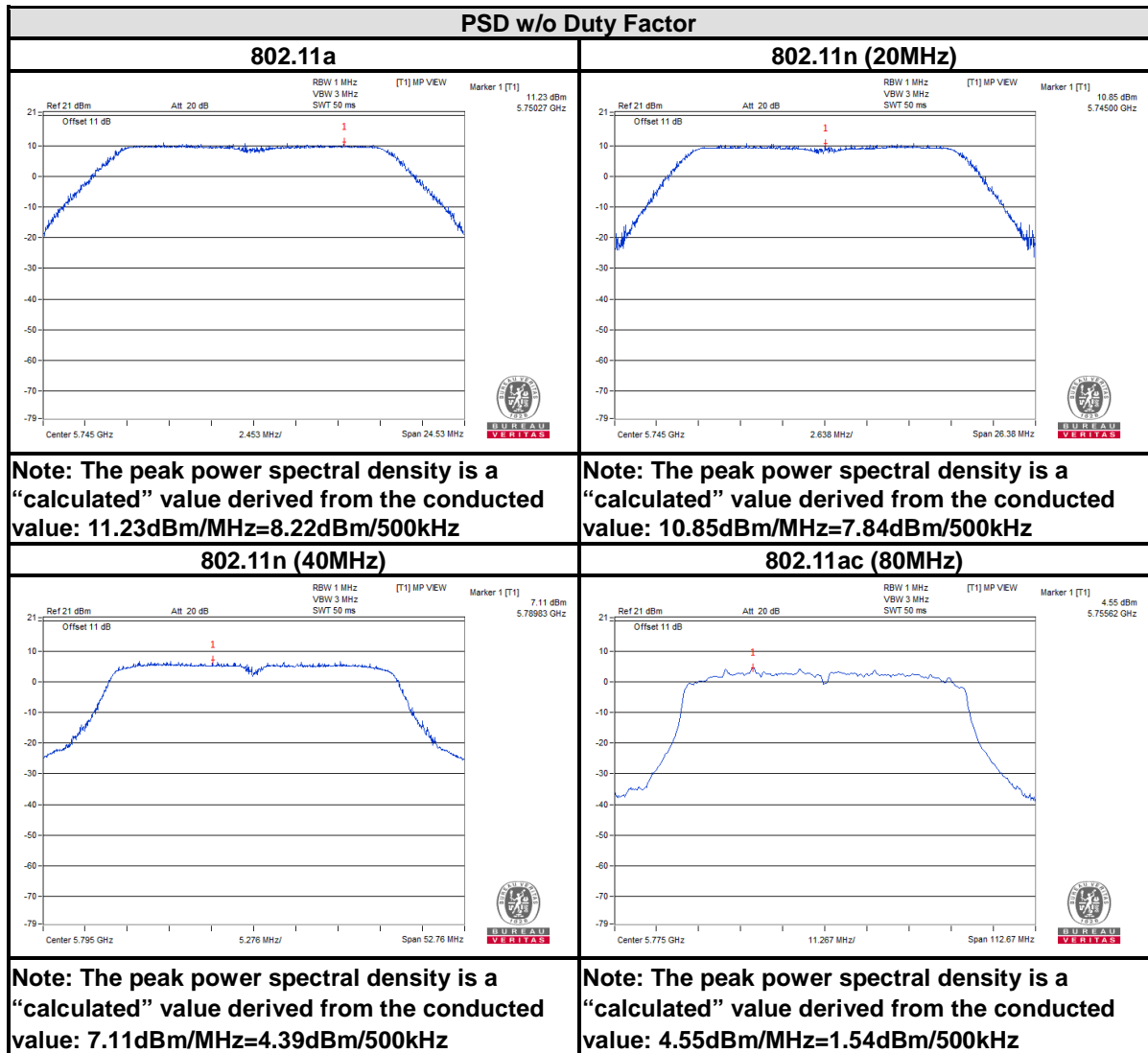



4.5 FREQUENCY STABILITY

4.5.1 LIMITS OF FREQUENCY STABILITY MEASUREMENT

The frequency of the carrier signal shall be maintained within band of operation

4.5.2 TEST SETUP

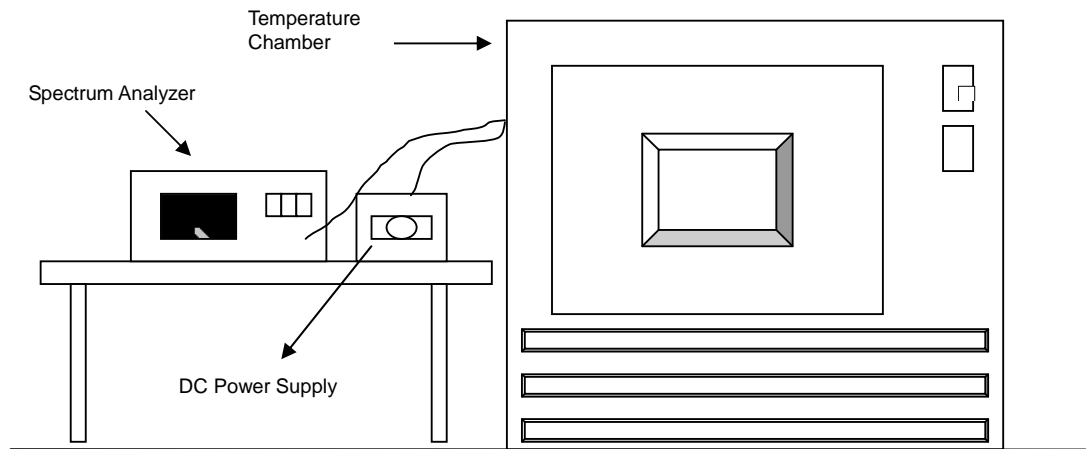

4.5.3 TEST INSTRUMENTS

Refer to section 4.1.3 to get information of above instrument.



4.5.4 TEST PROCEDURE

- a. The EUT was placed inside the environmental test chamber and powered by nominal DC voltage.
- b. Turn the EUT on and couple its output to a spectrum analyzer.
- c. Turn the EUT off and set the chamber to the highest temperature specified.
- d. Allow sufficient time (approximately 30 min) for the temperature of the chamber to stabilize, turn the EUT on and measure the operating frequency after 2, 5, and 10 minutes.
- e. Repeat step 2 and 3 with the temperature chamber set to the lowest temperature.
- f. The test chamber was allowed to stabilize at +20 degree C for a minimum of 30 minutes. The supply voltage was then adjusted on the EUT from 85% to 115% and the frequency record.

4.5.5 DEVIATION FROM TEST STANDARD

No deviation.

4.5.6 EUT OPERATING CONDITION

Set the EUT transmit at un-modulation mode to test frequency stability.



4.5.7 TEST RESULTS

FREQUENCY STABILITY VERSUS TEMP.									
OPERATING FREQUENCY: 5180MHz									
TEMP. (°C)	POWER SUPPLY (Vdc)	0 MINUTE		2 MINUTES		5 MINUTES		10 MINUTE	
		Measured Frequency (MHz)	Frequency Drift (ppm)	Measured Frequency (MHz)	Frequency Drift (ppm)	Measured Frequency (MHz)	Frequency Drift (ppm)	Measured Frequency (MHz)	Frequency Drift (ppm)
50	3.85	5179.9736	-5.097	5179.9742	-4.981	5179.9775	-4.344	5179.9791	-4.035
40	3.85	5179.9782	-4.208	5179.9794	-3.977	5179.9717	-5.463	5179.9716	-5.483
30	3.85	5179.9966	-0.656	5179.9973	-0.521	5179.9976	-0.463	5179.9917	-1.602
20	3.85	5180.011	2.124	5180.0017	0.328	5180.0091	1.757	5180.0078	1.506
10	3.85	5180.0141	2.722	5180.018	3.475	5180.0172	3.320	5180.0144	2.780
0	3.85	5179.9923	-1.486	5179.9907	-1.795	5179.9931	-1.332	5179.9989	-0.212
-10	3.85	5179.9867	-2.568	5179.9938	-1.197	5179.9959	-0.792	5179.992	-1.544
-20	3.85	5179.9867	-2.568	5179.9809	-3.687	5179.9878	-2.355	5179.9784	-4.170
-30	3.85	5180.0251	4.846	5180.0201	3.880	5180.0224	4.324	5180.0231	4.459

FREQUENCY STABILITY VERSUS VOLTAGE									
OPERATING FREQUENCY: 5180MHz									
TEMP. (°C)	POWER SUPPLY (Vdc)	0 MINUTE		2 MINUTE		5 MINUTE		10 MINUTE	
		Measured Frequency (MHz)	Frequency Drift (ppm)	Measured Frequency (MHz)	Frequency Drift (ppm)	Measured Frequency (MHz)	Frequency Drift (ppm)	Measured Frequency (MHz)	Frequency Drift (ppm)
20	4.4	5180.011	2.124	5180.0025	0.483	5180.0093	1.795	5180.0083	1.602
	3.85	5180.011	2.124	5180.0017	0.328	5180.0091	1.757	5180.0078	1.506
	3.3	5180.0103	1.988	5180.0015	0.290	5180.0092	1.776	5180.0083	1.602



FREQUENCY STABILITY VERSUS TEMP.									
OPERATING FREQUENCY: 5825MHz									
TEMP. (°C)	POWER SUPPLY (Vdc)	0 MINUTE		2 MINUTES		5 MINUTES		10 MINUTE	
		Measured Frequency (MHz)	Frequency Drift (ppm)	Measured Frequency (MHz)	Frequency Drift (ppm)	Measured Frequency (MHz)	Frequency Drift (ppm)	Measured Frequency (MHz)	Frequency Drift (ppm)
50	3.85	5825.0241	4.137	5825.0225	3.863	5825.0236	4.052	5825.0271	4.652
40	3.85								
30	3.85								
20	3.85								
10	3.85								
0	3.85								
-10	3.85								
-20	3.85								
-30	3.85								

FREQUENCY STABILITY VERSUS VOLTAGE									
OPERATING FREQUENCY: 5825MHz									
TEMP. (°C)	POWER SUPPLY (Vdc)	0 MINUTE		2 MINUTE		5 MINUTE		10 MINUTE	
		Measured Frequency (MHz)	Frequency Drift (ppm)	Measured Frequency (MHz)	Frequency Drift (ppm)	Measured Frequency (MHz)	Frequency Drift (ppm)	Measured Frequency (MHz)	Frequency Drift (ppm)
20	4.4								
	3.85								
	3.3								



**BUREAU
VERITAS**

Test Report No.: RF161008W001-6

5 PHOTOGRAPHS OF THE TEST CONFIGURATION

Please refer to the attached file (Test Setup Photo).



**BUREAU
VERITAS**

Test Report No.: RF161008W001-6

6 APPENDIX A – MODIFICATIONS RECORDERS FOR ENGINEERING CHANGES TO THE EUT BY THE LAB

No modifications were made to the EUT by the lab during the test.

---END---