

TEST REPORT

ACCORDING TO: FCC CFR 47 Part 15 subpart F, section 15.519 and subpart B

FOR:
Vayyar Imaging Ltd.
vHome Environment Sensor
Model: VS21CBT
FCC ID:2AHIS-VHOME

This report is in conformity with ISO/IEC 17025. The "A2LA Accredited" symbol endorsement applies only to the tests and calibrations that are listed in the scope of Hermon Laboratories accreditation. The test results relate only to the items tested. This test report shall not be reproduced in any form except in full with the written approval of Hermon Laboratories Ltd.



Table of contents

1	Applicant information.....	3
2	Equipment under test attributes	3
3	Manufacturer information	3
4	Test details.....	3
5	Tests summary.....	4
6	EUT description.....	5
6.1	General information.....	5
6.2	Ports and lines	5
6.3	Auxiliary equipment.....	5
6.4	Changes made in EUT	5
6.5	Test configuration.....	5
6.6	Transmitter characteristics	6
7	Transmitter tests according to 47CFR part 15 requirements.....	7
7.1	Occupied bandwidth test.....	7
7.2	Peak power within 50 MHz bandwidth and Radiated power density	10
7.3	Radiated spurious emission measurements.....	16
7.4	Transmission duration requirements	35
7.5	Conducted emissions	37
8	Unintentional emissions	40
8.1	Conducted emissions	40
8.2	Radiated emission measurements	44
9	APPENDIX A Test equipment and ancillaries used for tests.....	50
10	APPENDIX B Measurement uncertainties.....	51
11	APPENDIX C Test laboratory description	52
12	APPENDIX D Specification references	52
13	APPENDIX E Test equipment correction factors.....	53
14	APPENDIX F Abbreviations and acronyms.....	63



1 Applicant information

Client name: Vayyar Imaging LTD.
Address: 11 Altalef street, Yehud, 5621608, Israel
Telephone: +972 54 432 1050
E-mail: mark.popov@vayyar.com
Contact name: Mr. Mark Popov

2 Equipment under test attributes

Product name: vHome Environment Sensor
Product type: UWB Handheld Device
Model(s): VS21CBT
Serial number: H21GAA00818S0080
Hardware version: REV_A
Software release: SDK ver. 1.0.12
Receipt date 24-Jun-18

3 Manufacturer information

Manufacturer name: Vayyar Imaging LTD.
Address: 11 Altalef street, Yehud, 5621608, Israel
Telephone: +972 54 432 1050
E-Mail: mark.popov@vayyar.com
Contact name: Mr. Mark Popov

4 Test details

Project ID: 31088
Location: Hermon Laboratories Ltd. Harakevet Industrial Zone, Binyamina 30500, Israel
Test started: 24-Jun-18
Test completed: 3-Sep-18
Test specification(s): FCC CFR 47 Part 15 subpart F, section 15.519; subpart B



5 Tests summary

Test	Status
Transmitter characteristics	
FCC section 15.519(b), Occupied bandwidth	Pass
FCC section 15.519(c), Radiated power density	Pass
FCC section 15.519(c)/15.209, Radiated spurious emissions below 960 MHz	Pass
FCC section 15.519(c), (d), Radiated spurious emissions above 960 MHz	Pass
FCC section 15.519(e), Peak power within 50 MHz bandwidth	Pass
FCC section 15.519(a)(1), Transmission duration requirements	Pass
FCC section 15.207(a), Conducted emission	Pass
Unintentional emissions	
FCC section 15.107, Conducted emission at AC power port	Pass
FCC section 15.109, Radiated emission	Pass

Testing was completed against all relevant requirements of the test standard. The results obtained indicate that the product under test complies in full with the requirements tested.
The test results relate only to the items tested. Pass/ fail decision was based on nominal values.

This test report supersedes the previously issued test report identified by Doc ID:VAYRAD_FCC.31088_rev3.

	Name and Title	Date	Signature
Tested by:	Mr. A. Morozov, test engineer	June 26, 2018	
Reviewed by:	Mrs. M. Cherniavsky, certification engineer	September 18, 2018	
Approved by:	Mr. S. Samokha, Technical Manager, EMC and Radio	September 18, 2018	



6 EUT description

6.1 General information

The EUT, vHome product, is a multi-antenna sensor for characterizing the environment in the vicinity of the sensor by collecting and analyzing propagation information between the antennas, which is affected by the environment. The information is gathered by sequentially transmitting from the available antennas and collecting the received information at the rest of the antennas. The response information is then processed at the hosting device to obtain spatial information about the environment.

The acquisition is controlled by the hosting device. The hosting device may ask vHome to acquire multiple snapshots, so as to integrate the data into information about larger spatial extent, or to detect changes in the environment.

6.2 Ports and lines

Port type	Port description	Connected from	Connected to	Qty.	Cable type	Cable length
Telecom	USB	EUT	USB hub	1	Shielded	2 m

6.3 Auxiliary equipment

Description	Manufacturer	Model number	Serial number
Laptop	Lenovo	E470	PF-ONL2VL
USB hub	Texas Instruments	TUSB8041RGCEVM	6656574

6.4 Changes made in EUT

No changes were performed in the EUT during testing.

6.5 Test configuration

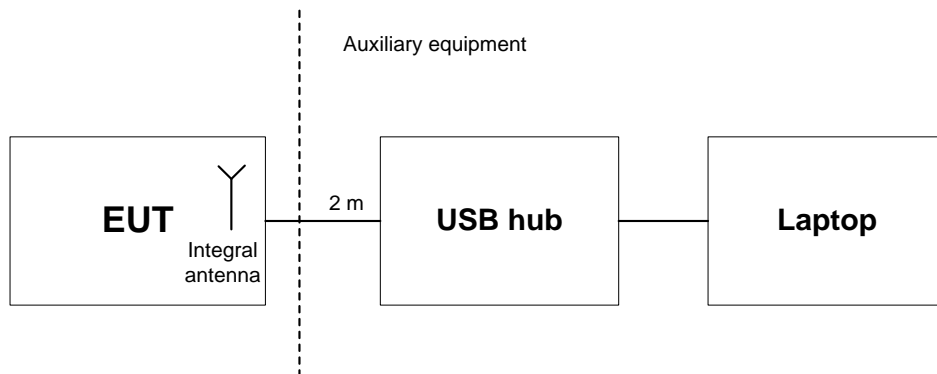



6.6 Transmitter characteristics

Type of equipment						
Stand-alone (Equipment with or without its own control provisions)						
Combined equipment (Equipment where the radio part is fully integrated within another type of equipment)						
V	Plug-in card (Equipment intended for a variety of host systems)					
Assigned frequency range		3100 – 10600 MHz				
Operating frequencies for FCC		6200.0 – 8400.0 MHz				
Is transmitter output power variable?		V		No		
				continuous variable		
		Yes		stepped variable with stepsize		dB
				minimum RF power		dBm
				maximum RF power		dBm
Antenna connection						
unique coupling		standard connector		V	Integral	
				V	with temporary RF connector	
				V	without temporary RF connector	
Antenna/s technical characteristics						
Type		Manufacturer		Model number		
PCB embedded slot		Vayyar Imaging Ltd.		VS21CBT		
Transmitter aggregate data rate/s		No payload				
Type of modulation		Multi-chirp				
Modulating test signal (baseband)		Multi-chirp				
Transmitter power source						
Battery		Nominal rated voltage				
V	DC	Nominal rated voltage		5.0 V		
AC mains		Nominal rated voltage		Frequency	Hz	



Test specification: Section 15.519(b), 15.503(d), Occupied bandwidth			
Test procedure: ANSI C63.10-2013, section 10.1			
Test mode: Compliance		Verdict: PASS	
Date(s): 24-Jun-18			
Temperature: 25 °C	Relative Humidity: 56 %	Air Pressure: 1008 hPa	Power: Battery
Remarks:			

7 Transmitter tests according to 47CFR part 15 requirements

7.1 Occupied bandwidth test

7.1.1 General

This test was performed to measure transmitter occupied bandwidth. Specification test limits are given in Table 7.1.1.

Table 7.1.1 Occupied bandwidth limits

Assigned frequency, MHz	Modulation envelope reference points*, dBc	Minimum allowed bandwidth, MHz
3100 - 10600	10	500

* - Modulation envelope reference points are provided in terms of attenuation below the unmodulated carrier.

7.1.2 Test procedure

7.1.2.1 The EUT was set up as shown in Figure 7.1.1, energized and its proper operation was checked.

7.1.2.2 The EUT was set to transmit the normally modulated carrier and the peak power envelope was captured with PEAK HOLD function.

7.1.2.3 The transmitter occupied bandwidth was measured with spectrum analyzer as a frequency delta between the reference points on modulation envelope and provided in Table 7.1.2 and the associated plots.

Figure 7.1.1 Occupied bandwidth test setup

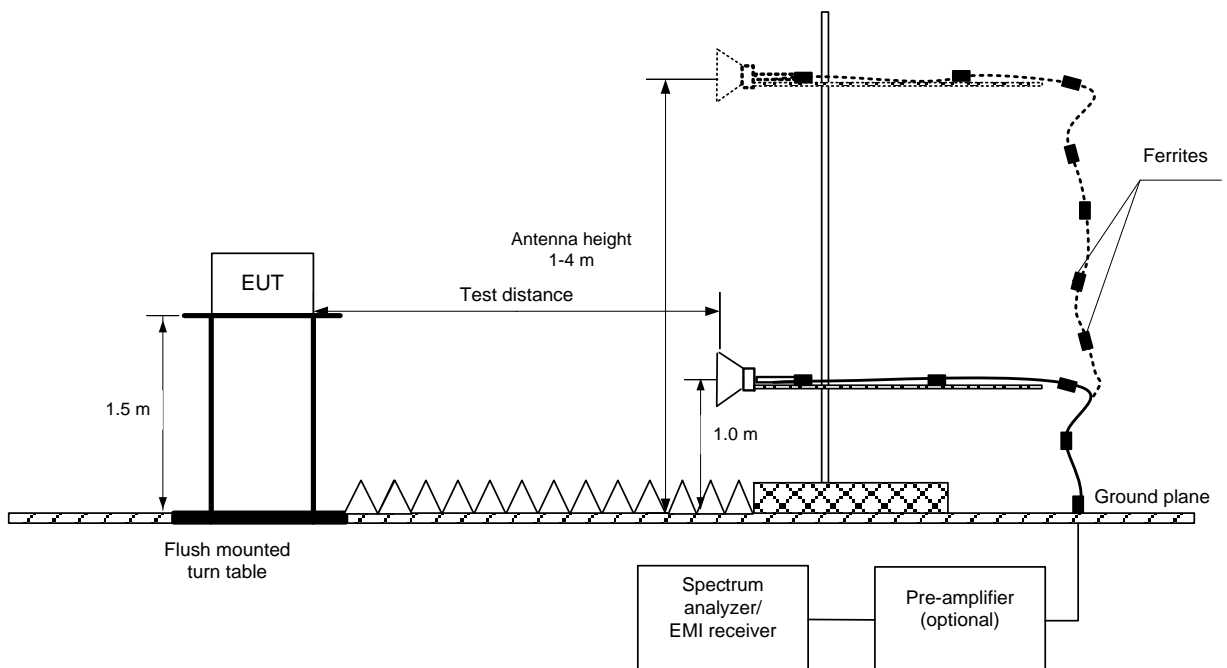



Test specification:		Section 15.519(b), 15.503(d), Occupied bandwidth	
Test procedure:		ANSI C63.10-2013, section 10.1	
Test mode:		Compliance	
Date(s):		24-Jun-18	
Temperature: 25 °C		Relative Humidity: 56 %	Air Pressure: 1008 hPa
Power: Battery		Verdict: PASS	
Remarks:			

Table 7.1.2 Occupied bandwidth test results

CENTER FREQUENCY f_c : 7325 MHz
DETECTOR USED: Peak hold
RESOLUTION BANDWIDTH: 1 MHz
VIDEO BANDWIDTH: 8 MHz
MODULATION: Multi-Chirp
MODULATION ENVELOPE REFERENCE POINTS: 10 dBc

Carrier frequency f_m , MHz	-10 dB envelope points, MHz		Occupied bandwidth, MHz	Limit, MHz	Margin, MHz	Verdict
	f_l	f_h				
7008.0	6333.0	8317.0	1983.0	500.0	1483.0	Pass

Reference numbers of test equipment used

HL 3818	HL 3903	HL 4933				
---------	---------	---------	--	--	--	--

Full description is given in Appendix A.



HERMON LABORATORIES

Test specification: Section 15.519(b), 15.503(d), Occupied bandwidth			
Test procedure: ANSI C63.10-2013, section 10.1			
Test mode: Compliance	Verdict: PASS		
Date(s): 24-Jun-18			
Temperature: 25 °C	Relative Humidity: 56 %	Air Pressure: 1008 hPa	Power: Battery
Remarks:			

Plot 7.1.1 Occupied bandwidth test result

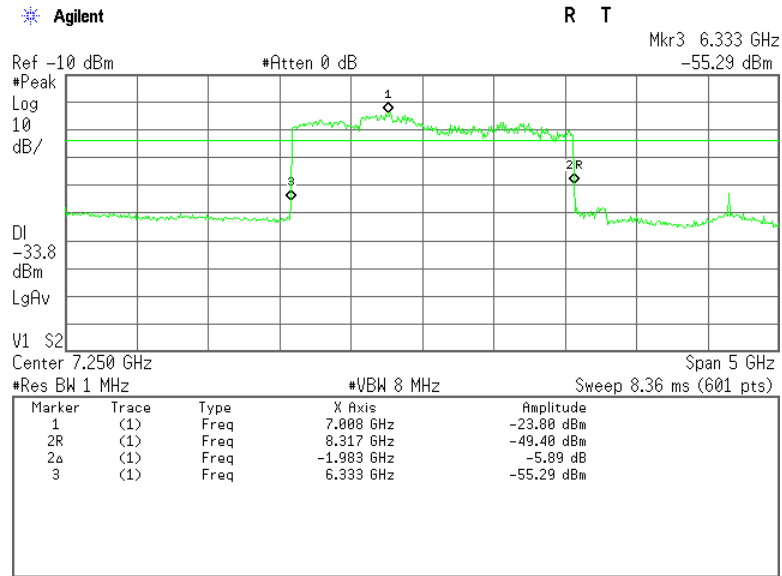



Test specification:		Sections 15.519(c),15.519(e), Peak power within 50 MHz bandwidth and Radiated power density	
Test procedure:		47 CFR, Section 15.521, ANSI C63.10-2013, section 10.3	
Test mode:		Compliance	
Date(s):		24-Jun-18	
Temperature: 25 °C		Relative Humidity: 56 %	
Air Pressure: 1008 hPa		Power: Battery	
Remarks:			

7.2 Peak power within 50 MHz bandwidth and Radiated power density

7.2.1 General

This test was performed to measure effective radiated power emanated by transmitter at carrier frequency. Specification test limits are given in Table 7.2.1, Table 7.2.2.

Table 7.2.1 Peak level of emissions contained within 50 MHz (EIRP)

Assigned frequency band, MHz	EIRP, dBm	Equivalent field strength limit @ 3m, dB(μ V/m) in 50 MHz*	Equivalent field strength limit @ 1m, dB(μ V/m) in 50 MHz**
3100 - 10600	0	95.2	104.7

* - Equivalent field strength @ 3m, dB(μ V/m) = EIRP, dBm + 95.2 dB

** - Equivalent field strength @ 1m, dB(μ V/m) = EIRP, dBm + 104.7 dB

Table 7.2.2 Average level of emissions (EIRP) in 1 MHz BW

Assigned frequency band, MHz	EIRP dBm/1MHz	Equivalent field strength limit @ 3m, dB(μ V/m)/1MHz*	Equivalent field strength limit @ 1m, dB(μ V/m)/1MHz**
FCC section 15.519(c)			
3100 - 10600	-41.3	53.9	63.4

* - Equivalent field strength @ 3m, dB(μ V/m) = EIRP, dBm + 95.2 dB

** - Equivalent field strength @ 1m, dB(μ V/m) = EIRP, dBm + 104.7 dB

7.2.2 Test procedure for field strength measurements

7.2.2.1 The EUT was set up as shown in Figure 7.2.1, energized and the performance check was conducted.

7.2.2.2 The field strength of the EUT carrier frequency was measured with antenna connected to spectrum analyzer/ EMI receiver. To find maximum radiation the turntable was rotated 360°, the measuring antenna height was swept throughout the range, specified in Table 7.2.3, in both vertical and horizontal polarizations.

7.2.2.3 The worst test results (the lowest margins) were recorded in Table 7.2.3 and shown in the associated plot.

7.2.2.4 The peak measurements were performed with the widest available RBW of the measuring instrument and extrapolated to 50 MHz BW.

7.2.2.5 The average measurements were performed with an RMS detector with 1 msec averaging time as shown in Table 7.2.4 and the associated plot.



Test specification: Sections 15.519(c),15.519(e), Peak power within 50 MHz bandwidth and Radiated power density			
Test procedure: 47 CFR, Section 15.521, ANSI C63.10-2013, section 10.3			
Test mode: Compliance	Verdict: PASS		
Date(s): 24-Jun-18			
Temperature: 25 °C	Relative Humidity: 56 %	Air Pressure: 1008 hPa	Power: Battery
Remarks:			

Figure 7.2.1 Setup for carrier field strength measurements

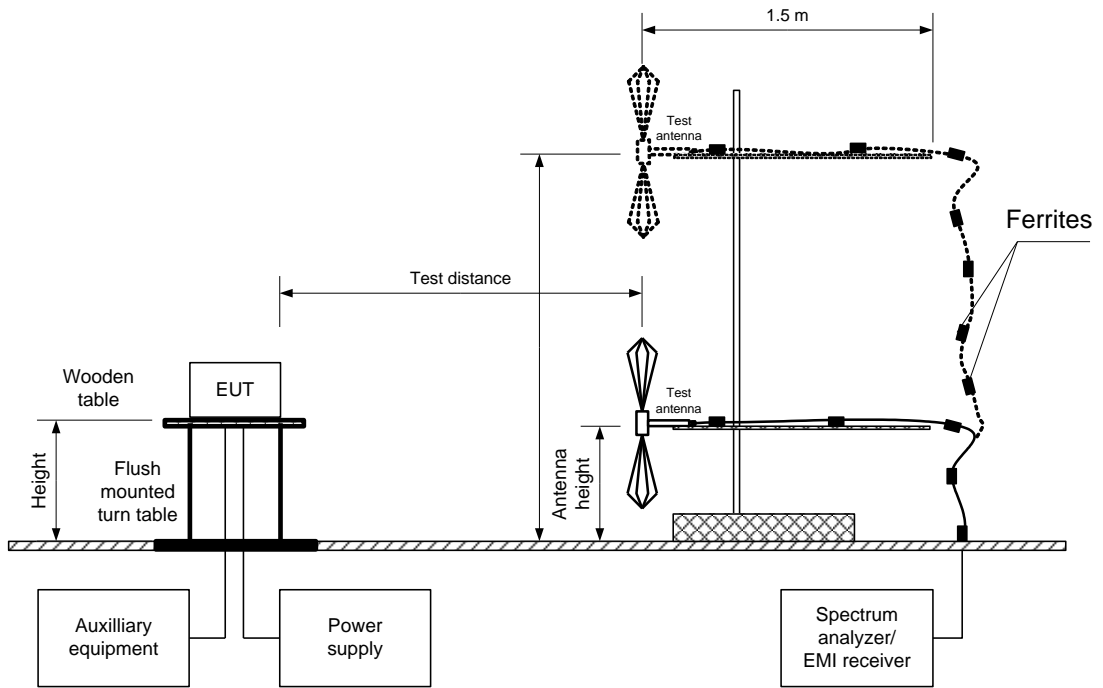



Test specification: Sections 15.519(c),15.519(e), Peak power within 50 MHz bandwidth and Radiated power density	
Test procedure: 47 CFR, Section 15.521, ANSI C63.10-2013, section 10.3	
Test mode: Compliance	Verdict: PASS
Date(s): 24-Jun-18	
Temperature: 25 °C	Relative Humidity: 56 %
Air Pressure: 1008 hPa	
Power: Battery	
Remarks:	

Table 7.2.3 Peak power level contained within 50 MHz test results

ASSIGNED FREQUENCY RANGE: 3100 – 10600 MHz
TEST SITE: Semi anechoic chamber
TEST DISTANCE: 1 m
EUT HEIGHT: 1.5 m
DETECTOR USED: Peak
VIDEO BANDWIDTH: > Resolution bandwidth
TEST ANTENNA TYPE: Horn
MODULATION: Multi-Chirp

Frequency, MHz	SA reading (RBW 10 MHz), dB(µV/m)	SA reading (RBW 28 MHz), dB(µV/m)	Conversion factor from 28 MHz to 50 MHz, dB*	EIRP, dBm**	Limit, dBm	Margin, dB***	Verdict
6705.130	91.01	91.24	-5.04	-8.42	0	-8.42	Pass
6817.974	93.30	93.53	-5.04	-6.13	0	-6.13	Pass
7027.750	94.32	94.55	-5.04	-5.11	0	-5.11	Pass
7029.763	94.45	94.68	-5.04	-4.98	0	-4.98	Pass
7308.157	92.40	92.63	-5.04	-7.03	0	-7.03	Pass
7501.257	91.42	91.65	-5.04	-8.01	0	-8.01	Pass
7625.423	91.91	92.14	-5.04	-7.52	0	-7.52	Pass
7829.646	91.56	91.79	-5.04	-7.87	0	-7.87	Pass
7987.625	92.31	92.54	-5.04	-7.12	0	-7.12	Pass
8148.218	92.81	93.04	-5.04	-6.62	0	-6.62	Pass
8295.854	91.99	92.22	-5.04	-7.44	0	-7.44	Pass

*- Conversion factor=20 log (28/50) = -5.04 dB

**- EIRP, dBm= Equivalent field strength (28 MHz RBW), dB(µV/m) -104.7 dB- Conversion factor (28 to 50 MHz)

***- Margin, dB = EIRP, dBm – Limit, dBm



Test specification:		Sections 15.519(c),15.519(e), Peak power within 50 MHz bandwidth and Radiated power density	
Test procedure:		47 CFR, Section 15.521, ANSI C63.10-2013, section 10.3	
Test mode:		Compliance	
Date(s):		24-Jun-18	
Temperature: 25 °C		Relative Humidity: 56 %	
		Air Pressure: 1008 hPa	
		Power: Battery	
Remarks:			

Table 7.2.4 RMS-average emissions test results

ASSIGNED FREQUENCY RANGE: 3100 - 10600 MHz
TEST DISTANCE: 1 m
TEST SITE: Semi anechoic chamber
INVESTIGATED FREQUENCY RANGE: 6000 – 8500 MHz
DETECTOR USED: RMS (1 ms averaging time over bin)
VIDEO BANDWIDTH: > Resolution bandwidth
TEST ANTENNA TYPE: Log-periodic (960 MHz – 1000 MHz)
Double ridged guide (above 1000 MHz)
MODULATION: Multi-Chirp

Frequency, MHz	RMS Field strength, dB(μV/m)	RBW, MHz	Antenna polarization	EIRP, dBm*	Limit, dBm	Margin, dB**	Verdict
6548.830	58.67	1	Vertical	-46.03	-41.3	-4.73	Pass
6706.445	59.77	1	Vertical	-44.93	-41.3	-3.63	Pass
6838.060	61.37	1	Vertical	-43.33	-41.3	-2.03	Pass
7029.077	63.13	1	Vertical	-41.57	-41.3	-0.27	Pass
7179.466	62.81	1	Vertical	-41.89	-41.3	-0.59	Pass
7298.920	60.82	1	Vertical	-43.88	-41.3	-2.58	Pass
7508.680	60.06	1	Vertical	-44.64	-41.3	-3.34	Pass
7634.291	60.72	1	Vertical	-43.98	-41.3	-2.68	Pass
7828.963	60.35	1	Vertical	-44.35	-41.3	-3.05	Pass
7976.700	62.05	1	Vertical	-42.65	-41.3	-1.35	Pass
8148.960	61.55	1	Vertical	-43.15	-41.3	-1.85	Pass

*-EIRP, dBm = Field strength, dB(μV/m) – 104.7 dB

** - Margin = EIRP, dBm – specification limit.

Reference numbers of test equipment used

HL 4277	HL 4355	HL 4360	HL 4933	HL 5111			
---------	---------	---------	---------	---------	--	--	--

Full description is given in Appendix A.



HERMON LABORATORIES

Test specification:		Sections 15.519(c),15.519(e), Peak power within 50 MHz bandwidth and Radiated power density	
Test procedure:		47 CFR, Section 15.521, ANSI C63.10-2013, section 10.3	
Test mode:		Verdict: PASS	
Date(s):		24-Jun-18	
Temperature: 25 °C	Relative Humidity: 56 %	Air Pressure: 1008 hPa	Power: Battery
Remarks:			

Plot 7.2.1 Peak power level contained within 50 MHz

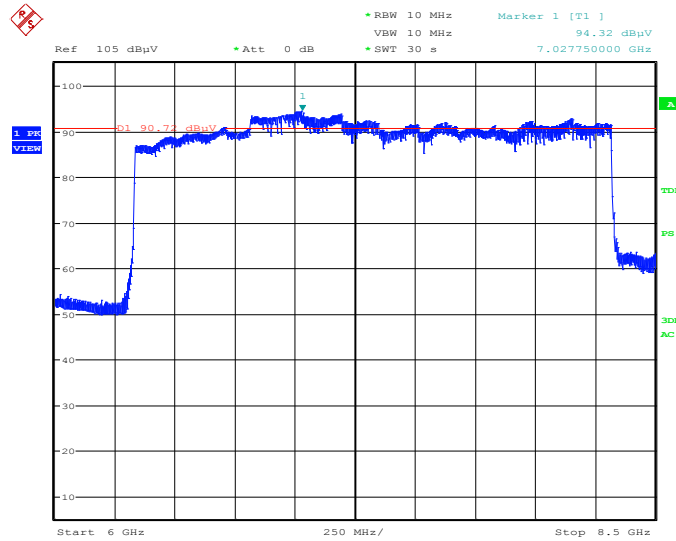

Date: 25 JUN 2018 03:54:42

Plot 7.2.2 Peak power level with 10 MHz and 28 MHz resolution bandwidth

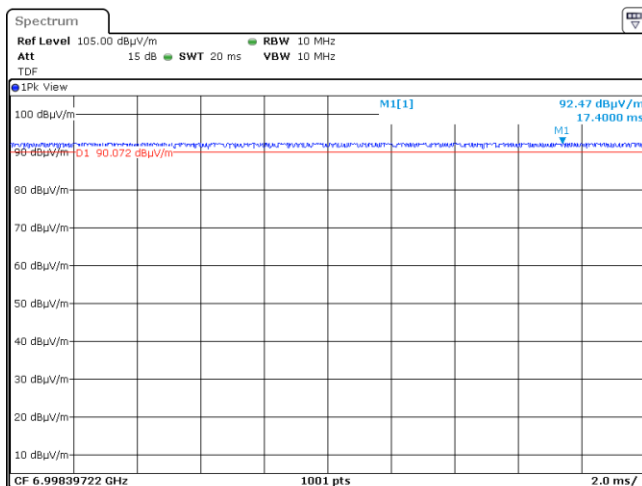

Date: 17 SEP 2018 15:39:53

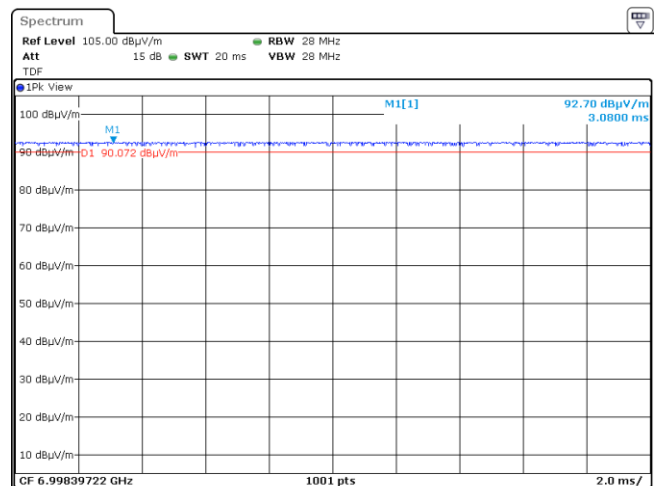

Date: 17 SEP 2018 15:33:12



Test specification:		Sections 15.519(c),15.519(e), Peak power within 50 MHz bandwidth and Radiated power density	
Test procedure:		47 CFR, Section 15.521, ANSI C63.10-2013, section 10.3	
Test mode:		Verdict: PASS	
Date(s):		24-Jun-18	
Temperature: 25 °C	Relative Humidity: 56 %	Air Pressure: 1008 hPa	Power: Battery
Remarks:			

Plot 7.2.3 RMS-Average emissions measurements

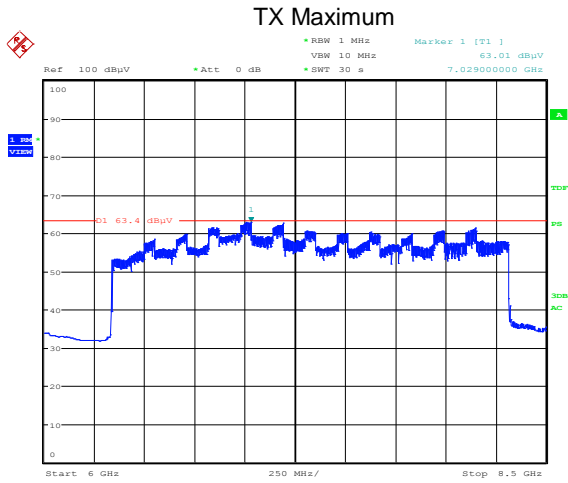

Date: 25.JUN.2018 03:31:37

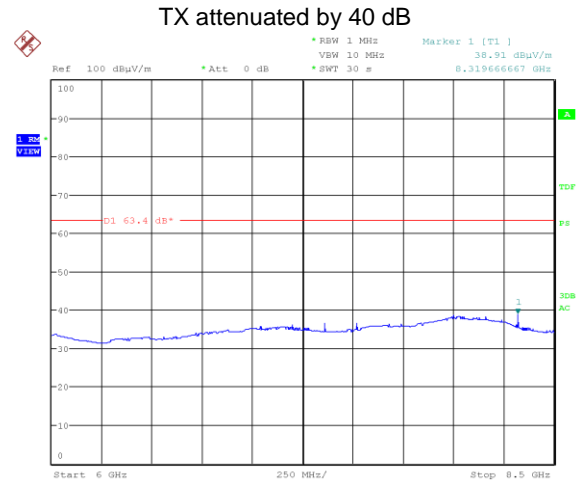

Date: 17.SEP.2018 09:48:28



Test specification:		Section 15.519(c),(d), Radiated spurious emissions	
Test procedure:		ANSI C63.10-2013, sections 10.2, 10.3, Section 15.521	
Test mode:		Verdict: PASS	
Date(s):			
Temperature: 24 °C		Relative Humidity: 48 %	Air Pressure: 1013 hPa
Power: Battery			
Remarks:			

7.3 Radiated spurious emission measurements

7.3.1 General

This test was performed to measure radiated spurious emissions from the EUT. Specification test limits are given in Table 7.3.1, Table 7.3.2. The EUT shall comply with the emission limits of Table 7.3.2 for UWB transmissions and associated spurious emissions while emissions from digital circuitry and other emissions not associated with UWB transmission shall comply with the limits of Table 7.3.1.

Table 7.3.1 Radiated spurious emission test limits according to section 15.209

Frequency, MHz	Field strength at 3 m, dB(µV/m)		
	Within restricted bands		
	Peak	Quasi Peak	Average
0.009 – 0.090	148.5 – 128.5	NA	128.5 – 108.5**
0.090 – 0.110	NA	108.5 – 106.8**	NA
0.110 – 0.490	126.8 – 113.8	NA	106.8 – 93.8**
0.490 – 1.705	NA	73.8 – 63.0**	NA
1.705 – 30.0*		69.5	
30 – 88		40.0	
88 – 216		43.5	
216 – 960		46.0	
960 – 10 th harmonic	74.0	NA	54.0

* - The limit for 3 m test distance was calculated using the inverse square distance extrapolation factor as follows:

$$\text{Lims}_2 = \text{Lims}_1 + 40 \log (S_1/S_2),$$

where S₁ and S₂ – standard defined and test distance respectively in meters.

** - The limit decreases linearly with the logarithm of frequency.

Table 7.3.2 Radiated emission average limits according to sections 15.519(c), 15.519(d)

Frequency, MHz	RBW, kHz	EIRP of spurious, dBm	Equivalent field strength limit @ 3m, dB(µV/m)***	Equivalent field strength limit @ 1m, dB(µV/m)****
960-1610	1000	-75.3	19.9	29.4
1610-1990	1000	-63.3	31.9	41.4
1990-3100	1000	-61.3	33.9	43.4
3100-10600	1000	-41.3	53.9	63.4
Above 10600	1000	-61.3	33.9	43.4
1164-1240	≥1	-85.3	9.9	19.4
1559-1610	≥1	-85.3	9.9	19.4

*** - Equivalent field strength @ 3m, dB(µV/m) = EIRP, dBm + 95.2 dB

**** - Equivalent field strength @ 1m, dB(µV/m) = EIRP, dBm + 104.7 dB



Test specification:		Section 15.519(c),(d), Radiated spurious emissions	
Test procedure:		ANSI C63.10-2013, sections 10.2, 10.3, Section 15.521	
Test mode:		Verdict: PASS	
Date(s):			
Temperature: 24 °C		Relative Humidity: 48 %	Air Pressure: 1013 hPa
Power: Battery			
Remarks:			

7.3.2 Test procedure for spurious emission field strength measurements in 9 kHz to 30 MHz band

- 7.3.2.1 The EUT was set up as shown in Figure 7.3.1, energized and the performance check was conducted.
- 7.3.2.2 The specified frequency range was investigated with antenna connected to spectrum analyzer. To find maximum radiation the turntable was rotated 360° and the measuring antenna was rotated around its vertical axis.
- 7.3.2.3 The worst test results (the lowest margins) were recorded in the associated tables and shown in the associated plots.

7.3.3 Test procedure for spurious emission field strength measurements within 30-1000 MHz

- 7.3.3.1 The EUT was set up as shown in Figure 7.3.2, energized and the performance check was conducted.
- 7.3.3.2 The specified frequency range was investigated with antenna connected to spectrum analyzer. To find maximum radiation the turntable was rotated 360° and the measuring antenna height was swept from 1 to 4 m in both, vertical and horizontal, polarizations.
- 7.3.3.3 The worst test results (the lowest margins) were recorded in the associated tables and shown in the associated plots.

7.3.4 Test procedure for spurious emission field strength measurements above 1000 MHz

- 7.3.4.1 The EUT was set up as shown in Figure 7.3.3, energized and the performance check was conducted.
- 7.3.4.2 The specified frequency range was investigated with antenna connected to spectrum analyzer. To find maximum radiation the turntable was rotated 360° and the measuring antenna height was swept from 1 to 4 m in both, vertical and horizontal, polarizations while keeping the EUT within antenna 3 dB beamwidth.
- 7.3.4.3 The worst test results (the lowest margins) were recorded in the associated tables and shown in the associated plots.

7.3.5 Test procedure for spurious emission field strength measurements in 1164-1240 MHz and 1559-1610 MHz

- 7.3.5.1 The EUT was set up as shown in Figure 7.3.3 and energized.
- 7.3.5.2 The specified frequency range was investigated with antenna connected to spectrum analyzer. To find maximum radiation the turntable was rotated 360° and the measuring antenna height was swept from 1 to 4 m in both, vertical and horizontal, polarizations.
- 7.3.5.3 The radiated emissions were measured with a Spectrum analyzer using an RMS detector. The RBW of 1 kHz and VBW of 3 kHz with a 1 msec averaging time were used. The SA settings are shown in the attached Plot 7.3.7 to Plot 7.3.21.
- 7.3.5.4 The worst test results (the lowest margins) were recorded in the associated tables and shown in the associated plots.



Test specification: Section 15.519(c),(d), Radiated spurious emissions			
Test procedure: ANSI C63.10-2013, sections 10.2, 10.3, Section 15.521			
Test mode: Compliance	Verdict: PASS		
Date(s): 25-Jun-18, 26-Jun-18			
Temperature: 24 °C	Relative Humidity: 48 %	Air Pressure: 1013 hPa	Power: Battery
Remarks:			

Figure 7.3.1 Setup for spurious emission field strength measurements in 9 kHz to 30 MHz band

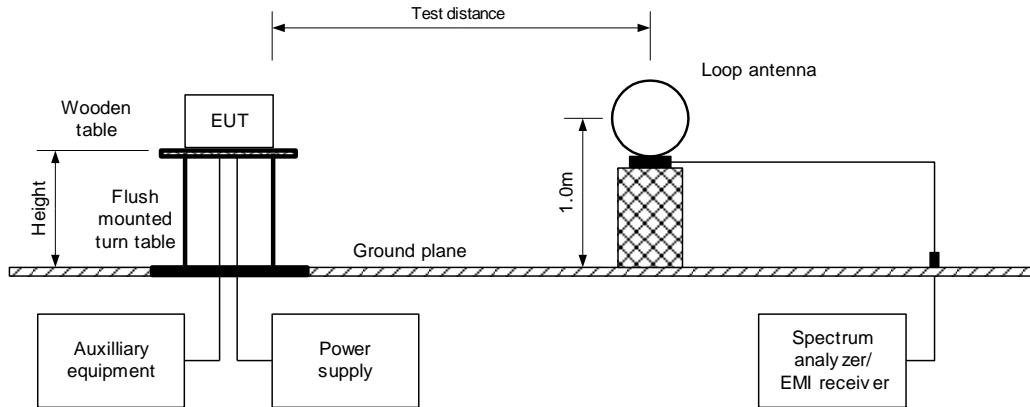
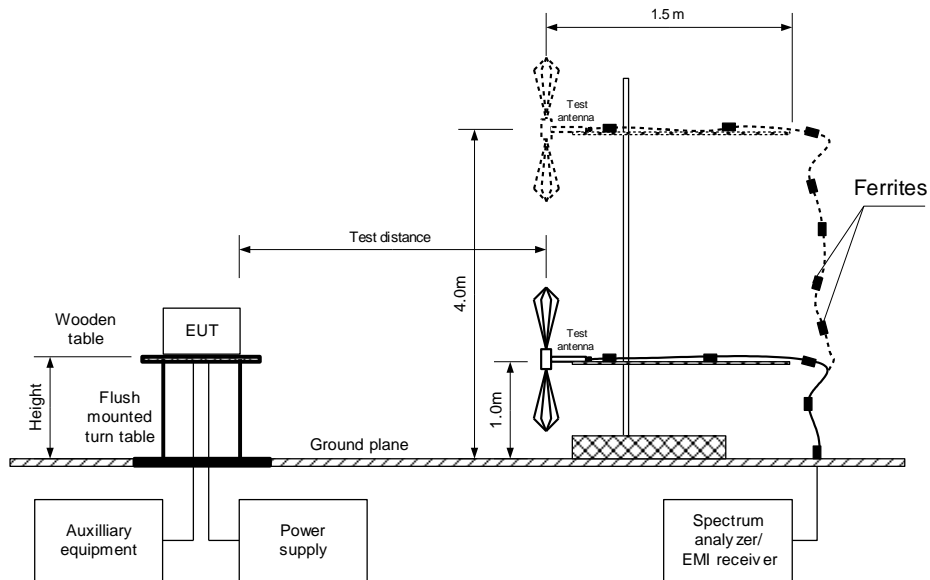

Figure 7.3.2 Setup for spurious emission field strength measurements within 30-1000 MHz





Test specification: Section 15.519(c),(d), Radiated spurious emissions			
Test procedure: ANSI C63.10-2013, sections 10.2, 10.3, Section 15.521			
Test mode: Compliance	Verdict: PASS		
Date(s): 25-Jun-18, 26-Jun-18			
Temperature: 24 °C	Relative Humidity: 48 %	Air Pressure: 1013 hPa	Power: Battery
Remarks:			

Figure 7.3.3 Setup for spurious emission field strength measurements above 1000 MHz

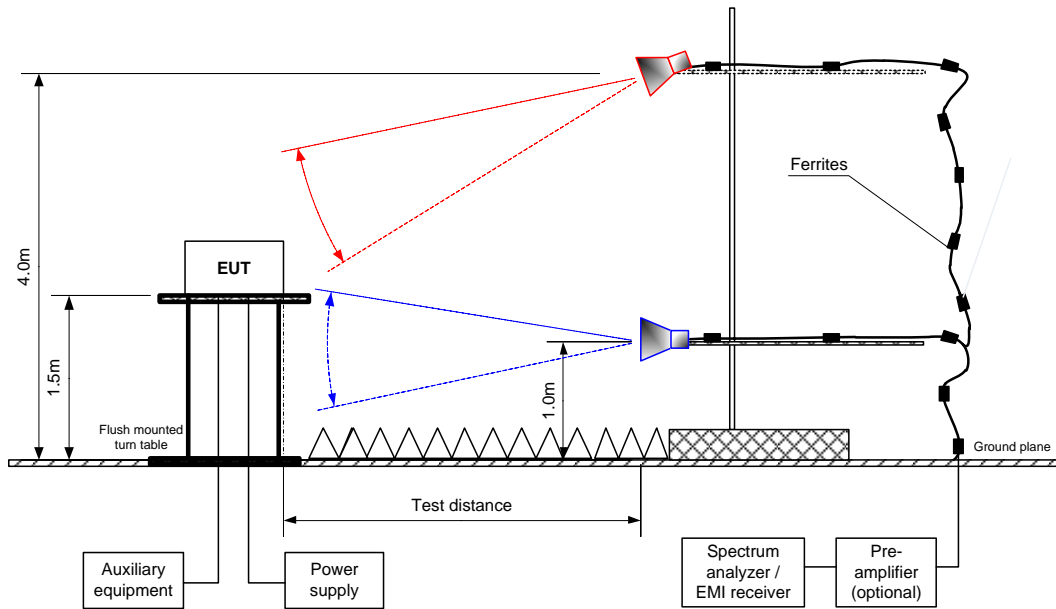



Test specification: Section 15.519(c),(d), Radiated spurious emissions			
Test procedure: ANSI C63.10-2013, sections 10.2, 10.3, Section 15.521			
Test mode: Compliance		Verdict: PASS	
Date(s): 25-Jun-18, 26-Jun-18			
Temperature: 24 °C	Relative Humidity: 48 %	Air Pressure: 1013 hPa	Power: Battery
Remarks:			

Table 7.3.3 Field strength of spurious emissions according to the Section 15.209

ASSIGNED FREQUENCY RANGE: 3100 - 10600 MHz
 TEST DISTANCE: 3 m
 TEST SITE: Semi anechoic chamber
 INVESTIGATED FREQUENCY RANGE: 0.009 – 1000 MHz
 DETECTOR USED: Peak
 VIDEO BANDWIDTH: ≥ Resolution bandwidth
 RESOLUTION BANDWIDTH: 1 kHz (9 kHz – 150 kHz)
 9.0 kHz (150 kHz – 30 MHz)
 120 kHz (30 MHz – 1000 MHz)
 TEST ANTENNA TYPE: Active loop (9 kHz – 30 MHz)
 Biconilog (30 MHz – 960 MHz)
 MODULATION: Multi-Chirp

Frequency, MHz	Peak emission, dB(µV/m)	Quasi-peak			Antenna polarization	Antenna height, m	Turn-table position**, degrees	Verdict
		Measured emission, dB(µV/m)	Limit, dB(µV/m)	Margin, dB*				
110.322167	25.57	16.24	43.50	-27.26	Vertical	100.0	-74.0	Pass
240.042333	39.55	32.76	46.00	-13.24	Vertical	100.0	-32.0	
336.741833	34.43	25.40	46.00	-20.60	Horizontal	102.0	18.0	
480.074833	35.30	29.76	46.00	-16.24	Vertical	102.0	128.0	
721.984667	43.16	33.95	46.00	-12.05	Horizontal	104.0	180.0	

*- Margin = Measured emission - specification limit.
 **- EUT front panel refer to 0 degrees position of turntable.

TEST SITE: SEMI ANECHOIC CHAMBER
 TEST DISTANCE: 3 m
 DETECTORS USED: PEAK / AVERAGE
 FREQUENCY RANGE: 1000 MHz – 40 000 MHz
 RESOLUTION BANDWIDTH: 1000 kHz

Frequency, MHz	Peak			Average			Antenna polarization	Antenna height, m	Turn-table position**, degrees	Verdict
	Measured emission, dB(µV/m)	Limit, dB(µV/m)	Margin, dB*	Measured emission, dB(µV/m)	Limit, dB(µV/m)	Margin, dB*				
14.719	55.49	74.0	-18.51	51.66	54.00	-2.34	Vertical	2.0	0	Pass
15.039	50.09	74.0	-23.91	48.95	54.00	-5.05	Vertical	1.8	0	Pass
15.679	55.96	74.0	-18.04	51.85	54.00	-2.15	Vertical	1.8	0	Pass
15.999	60.94	74.0	-13.06	50.98	54.00	-3.02	Vertical	1.4	0	Pass
16.244	58.30	74.0	-15.70	46.70	54.00	-7.30	Vertical	1.5	0	Pass
16.319	56.73	74.0	-17.27	46.54	54.00	-7.46	Vertical	1.6	0	Pass
17.599	57.09	74.0	-16.91	49.58	54.00	-4.42	Vertical	1.7	0	Pass
18.239	53.41	74.0	-20.59	48.72	54.00	-5.28	Vertical	1.5	0	Pass
18.559	54.04	74.0	-19.96	50.36	54.00	-3.64	Vertical	1.5	-180	Pass

*- Margin = Measured emission - specification limit.
 **- EUT front panel refer to 0 degrees position of turntable.



Test specification: Section 15.519(c),(d), Radiated spurious emissions	
Test procedure: ANSI C63.10-2013, sections 10.2, 10.3, Section 15.521	
Test mode: Compliance	Verdict: PASS
Date(s): 25-Jun-18, 26-Jun-18	
Temperature: 24 °C	Relative Humidity: 48 %
Remarks:	

Table 7.3.4 Spurious emission field strength test results according to the Section 15.519

ASSIGNED FREQUENCY RANGE: 3100 - 10600 MHz
 TEST DISTANCE: 1 m
 TEST SITE: Semi anechoic chamber
 INVESTIGATED FREQUENCY RANGE: 960 - 1610 & 10600 – 40000 MHz
 8500 – 40000 MHz
 DETECTOR USED: RMS with 1 ms averaging time
 VIDEO BANDWIDTH: > Resolution bandwidth
 TEST ANTENNA TYPE: Logperiodic (960 MHz – 1000 MHz)
 Double ridged guide (above 1000 MHz)
 MODULATION: Multi-Chirp

Frequency, MHz	Peak field strength, dB(μV/m)	RMS field strength, dB(μV/m)	RBW, kHz	Antenna polarization	EIRP, dBm*	Limit, dBm	Margin, dB**	Verdict
All emissions are produced by digital parts of the EUT and were measured according to the Section 15.209								Pass

*- EIRP, dBm = Field strength, dB(μV/m) – 104.7 dB
 **- Margin = EIRP, dBm – specification limit.

Table 7.3.5 Spurious emission field strength test results according to the Section 15.519

ASSIGNED FREQUENCY RANGE: 3100 - 10600 MHz
 TEST DISTANCE: 3 m
 TEST SITE: Semi anechoic chamber
 INVESTIGATED FREQUENCY RANGE: 1610 – 6000 & 8500 – 10600 MHz
 DETECTOR USED: RMS with 1 ms averaging time
 VIDEO BANDWIDTH: > Resolution bandwidth
 TEST ANTENNA TYPE: Double ridged guide (above 1000 MHz)
 MODULATION: Multi-Chirp

Frequency, MHz	Peak field strength, dB(μV/m)	RMS field strength, dB(μV/m)	RBW, kHz	Antenna polarization	EIRP, dBm*	Limit, dBm	Margin, dB**	Verdict
All emissions are produced by digital parts of the EUT and were measured according to the Section 15.209								Pass

*-EIRP, dBm = Field strength, dB(μV/m) – 95.2 dB
 **- Margin = EIRP, dBm – specification limit.

Reference numbers of test equipment used

HL 0034	HL 0446	HL 3615	HL 4277	HL 4355	HL 4360	HL 4933	HL 4956
HL 5111	HL 5288						

Full description is given in Appendix A.



Test specification: Section 15.519(c),(d), Radiated spurious emissions			
Test procedure: ANSI C63.10-2013, sections 10.2, 10.3, Section 15.521			
Test mode: Compliance	Verdict: PASS		
Date(s): 25-Jun-18, 26-Jun-18			
Temperature: 24 °C	Relative Humidity: 48 %	Air Pressure: 1013 hPa	Power: Battery
Remarks:			

Plot 7.3.1 Radiated emission measurements in 9 - 150 kHz range according to the Section 15.209

TEST SITE: Semi anechoic chamber
 ANTENNA POLARIZATION: Vertical and Horizontal
 TEST DISTANCE: 3 m

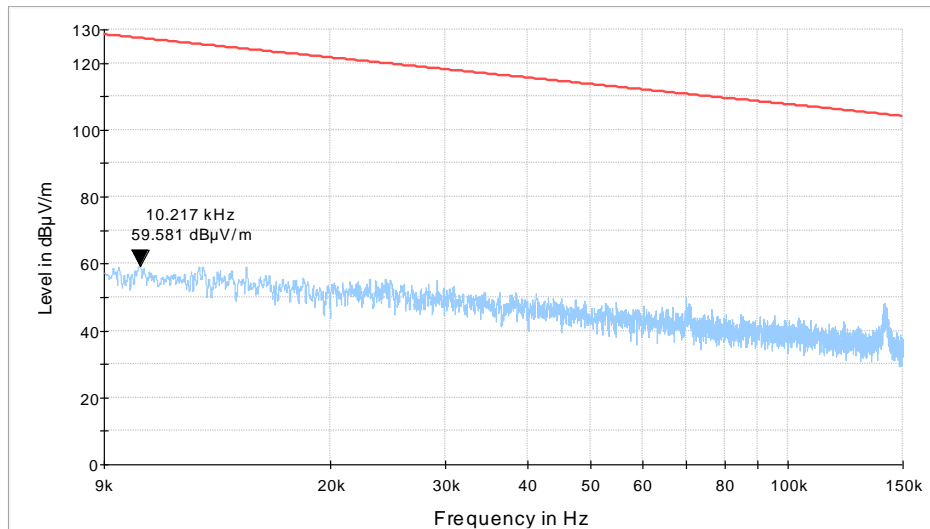

Plot 7.3.2 Radiated emission measurements in 0.15 - 30 MHz range according to the Section 15.209

TEST SITE: Semi anechoic chamber
 ANTENNA POLARIZATION: Vertical and Horizontal
 TEST DISTANCE: 3 m

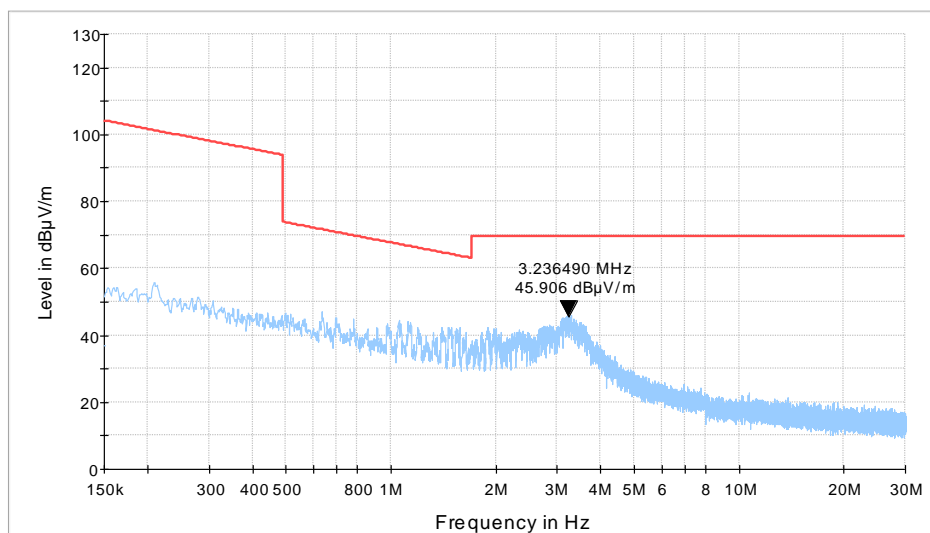



HERMON LABORATORIES

Test specification: Section 15.519(c),(d), Radiated spurious emissions			
Test procedure: ANSI C63.10-2013, sections 10.2, 10.3, Section 15.521			
Test mode: Compliance	Verdict: PASS		
Date(s): 25-Jun-18, 26-Jun-18			
Temperature: 24 °C	Relative Humidity: 48 %	Air Pressure: 1013 hPa	Power: Battery
Remarks:			

Plot 7.3.3 Radiated emission measurements in 30 - 1000 MHz range according to the Section 15.209

TEST SITE: Semi anechoic chamber
ANTENNA POLARIZATION: Vertical and Horizontal
TEST DISTANCE: 3 m

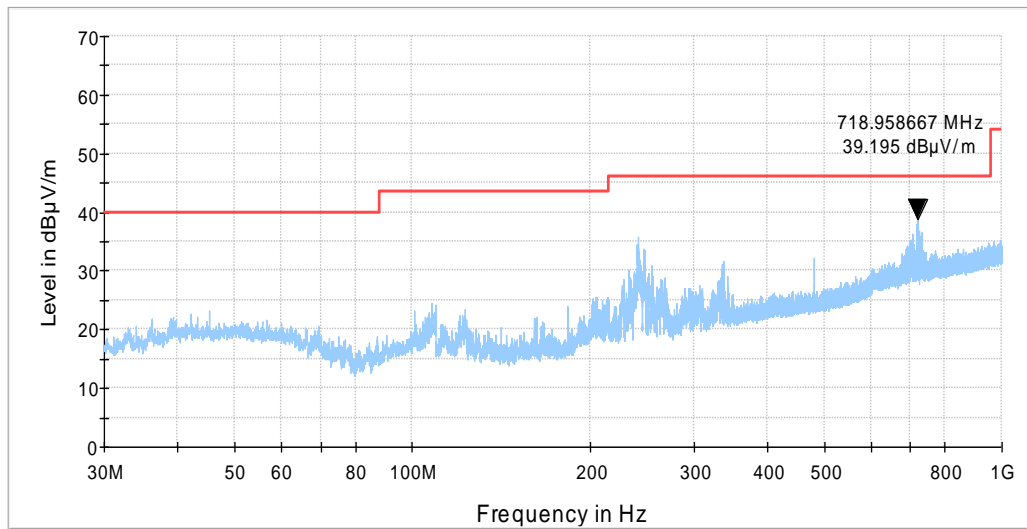



HERMON LABORATORIES

Test specification: Section 15.519(c),(d), Radiated spurious emissions			
Test procedure: ANSI C63.10-2013, sections 10.2, 10.3, Section 15.521			
Test mode: Compliance	Verdict: PASS		
Date(s): 25-Jun-18, 26-Jun-18			
Temperature: 24 °C	Relative Humidity: 48 %	Air Pressure: 1013 hPa	Power: Battery
Remarks:			

Plot 7.3.4 Radiated emission measurements in 1 – 11 GHz range according to the Section 15.209

TEST SITE: Semi anechoic chamber
ANTENNA POLARIZATION: Vertical and Horizontal
TEST DISTANCE: 3 m
TX Maximum

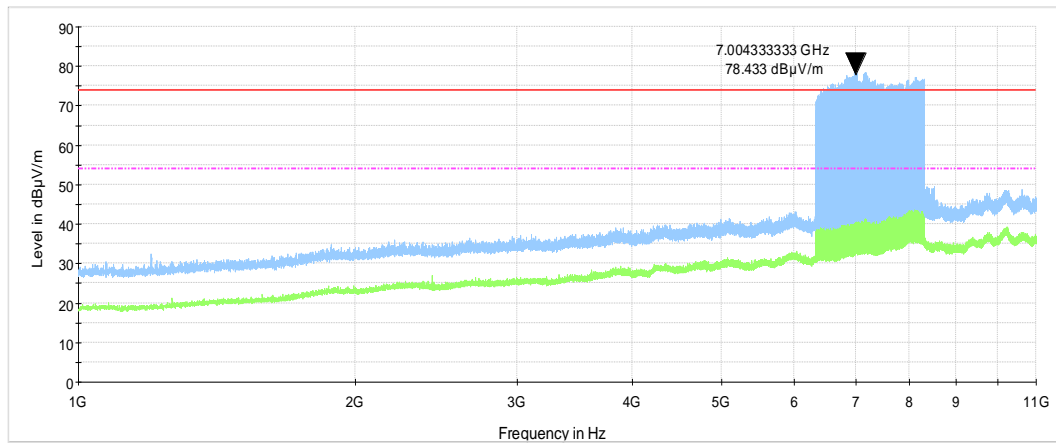

TX attenuated by 40 dB

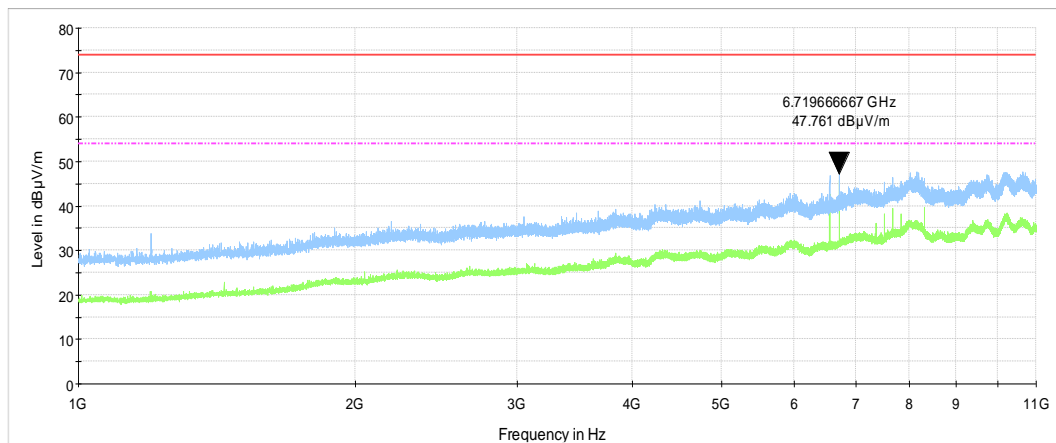



Test specification: Section 15.519(c),(d), Radiated spurious emissions			
Test procedure: ANSI C63.10-2013, sections 10.2, 10.3, Section 15.521			
Test mode: Compliance	Verdict: PASS		
Date(s): 25-Jun-18, 26-Jun-18			
Temperature: 24 °C	Relative Humidity: 48 %	Air Pressure: 1013 hPa	Power: Battery
Remarks:			

Plot 7.3.5 Radiated emission measurements in 11 – 18 GHz range according to the Section 15.209

TEST SITE: Semi anechoic chamber
ANTENNA POLARIZATION: Vertical and Horizontal
TEST DISTANCE: 3 m

TX Maximum

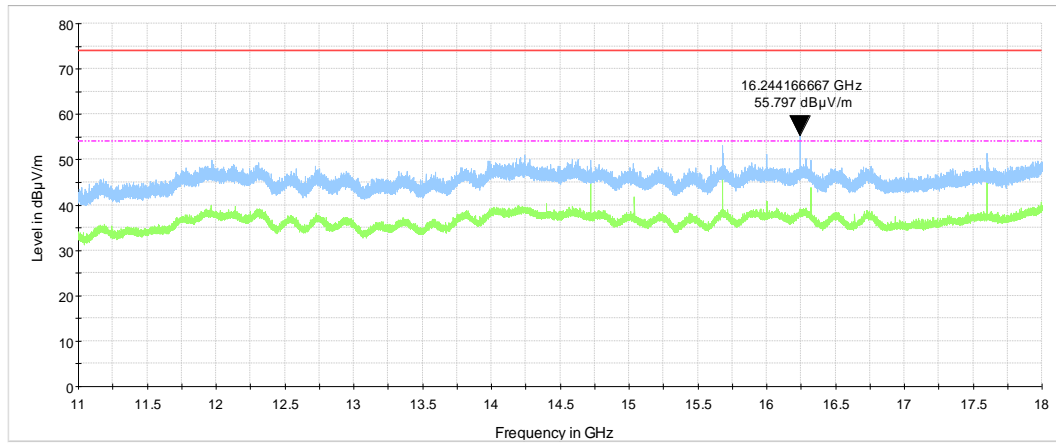

TX attenuated by 40 dB

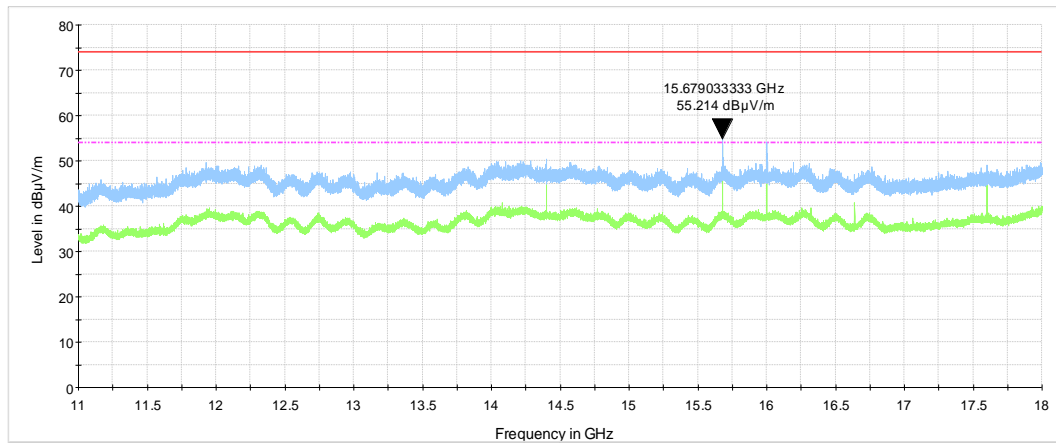



Test specification: Section 15.519(c),(d), Radiated spurious emissions			
Test procedure: ANSI C63.10-2013, sections 10.2, 10.3, Section 15.521			
Test mode: Compliance		Verdict: PASS	
Date(s): 25-Jun-18, 26-Jun-18			
Temperature: 24 °C	Relative Humidity: 48 %	Air Pressure: 1013 hPa	Power: Battery
Remarks:			

Plot 7.3.6 Radiated emission measurements in 18 - 40 GHz range according to the Section 15.209

TEST SITE:
ANTENNA POLARIZATION:
TEST DISTANCE:

Semi anechoic chamber
Vertical and Horizontal
3 m

TX Maximum

TX attenuated by 40 dB

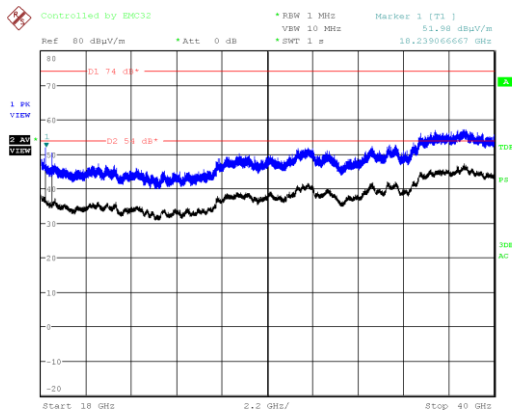

Date: 17.SEP.2018 11:32:33

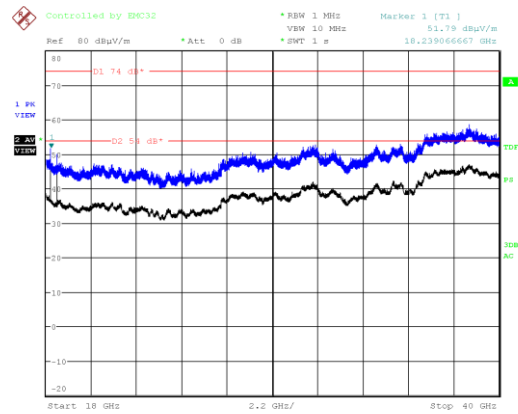

Date: 17.SEP.2018 11:11:23



Test specification: Section 15.519(c),(d), Radiated spurious emissions			
Test procedure: ANSI C63.10-2013, sections 10.2, 10.3, Section 15.521			
Test mode: Compliance		Verdict: PASS	
Date(s): 25-Jun-18, 26-Jun-18			
Temperature: 24 °C	Relative Humidity: 48 %	Air Pressure: 1013 hPa	Power: Battery
Remarks:			

Plot 7.3.7 Radiated emission measurements in 960 – 1000 MHz range according to the Section 15.519

TEST SITE:
ANTENNA POLARIZATION:
TEST DISTANCE:

Semi anechoic chamber
Vertical and Horizontal
1 m

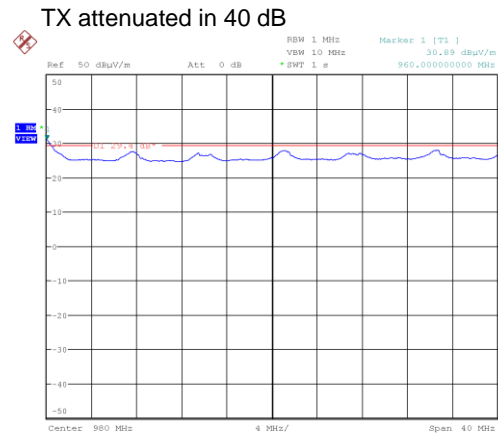
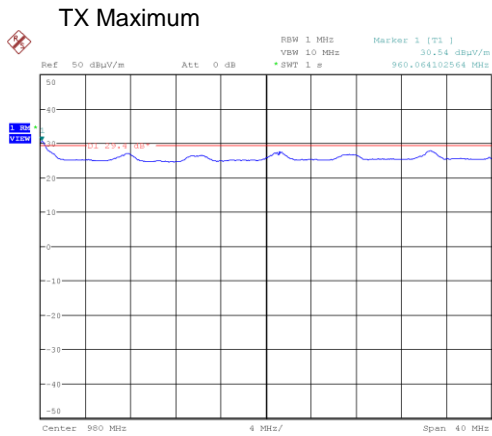

Date: 17_SEP.2018 04:10:52

Date: 17_SEP.2018 04:21:15

Note- the spurious emissions belong to the unintentional portion of transmitter

Plot 7.3.8 Radiated emission measurements in 1000 – 1610 MHz range according to the Section 15.519

TEST SITE:
ANTENNA POLARIZATION:
TEST DISTANCE:

Semi anechoic chamber
Vertical and Horizontal
1 m

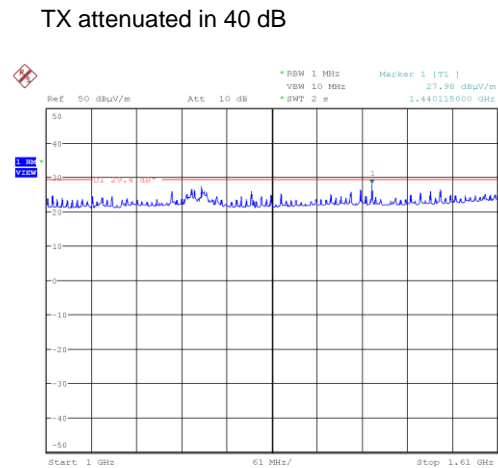
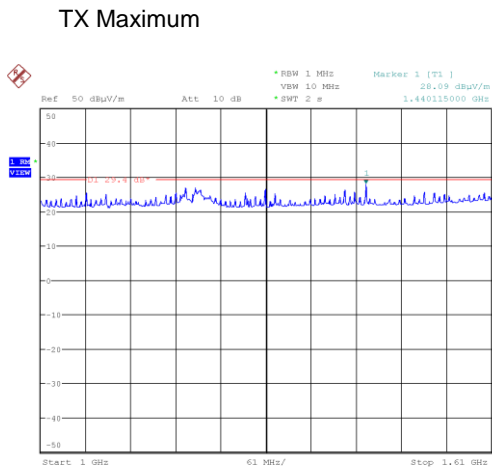

Date: 17_SEP.2018 06:17:39

Date: 17_SEP.2018 05:38:51

Note- the spurious emissions belong to the unintentional portion of transmitter



HERMON LABORATORIES

Test specification: Section 15.519(c),(d), Radiated spurious emissions			
Test procedure: ANSI C63.10-2013, sections 10.2, 10.3, Section 15.521			
Test mode: Compliance		Verdict: PASS	
Date(s): 25-Jun-18, 26-Jun-18			
Temperature: 24 °C	Relative Humidity: 48 %	Air Pressure: 1013 hPa	Power: Battery
Remarks:			

Plot 7.3.9 Radiated emission measurements in 1164 – 1240 MHz range according to the Section 15.519

TEST SITE:
ANTENNA POLARIZATION:
TEST DISTANCE:

Semi anechoic chamber
Vertical and Horizontal
1 m

TX Maximum
(turntable position -180 dgr)

TX attenuated by 40 dB
(turntable position -180 dgr)

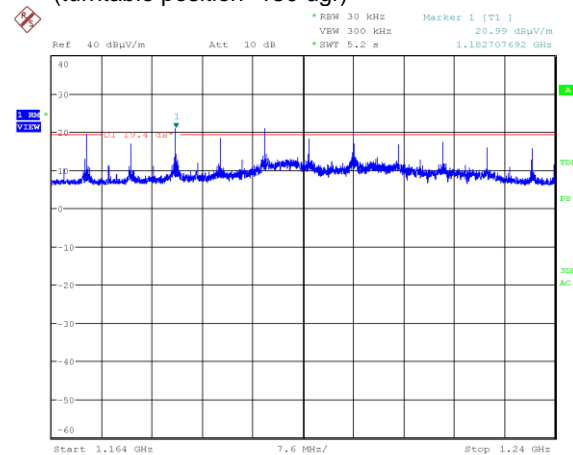
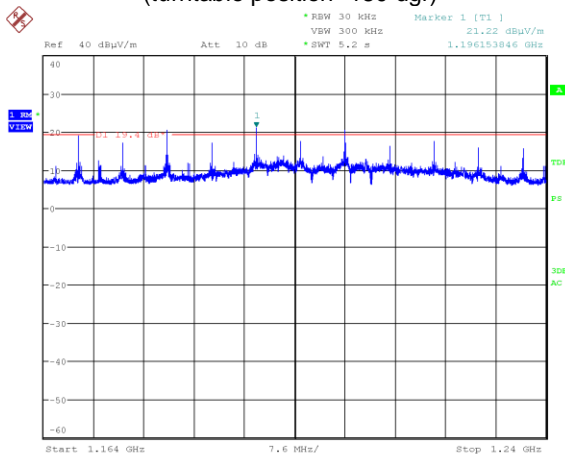

Date: 17.SEP.2018 07:52:19

Date: 17.SEP.2018 07:47:30

Note- the spurious emissions belong to the unintentional portion of transmitter

TX Maximum

TX attenuated by 40 dB

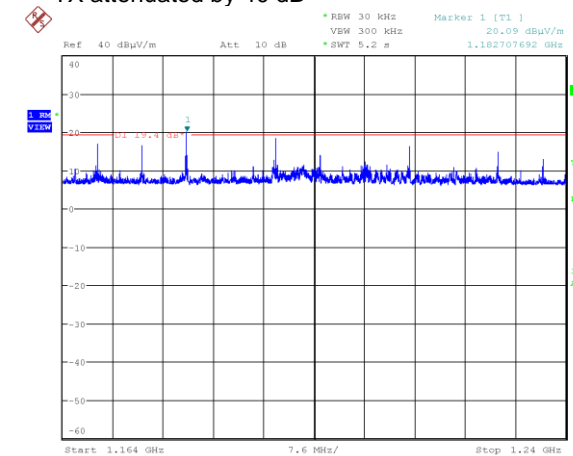
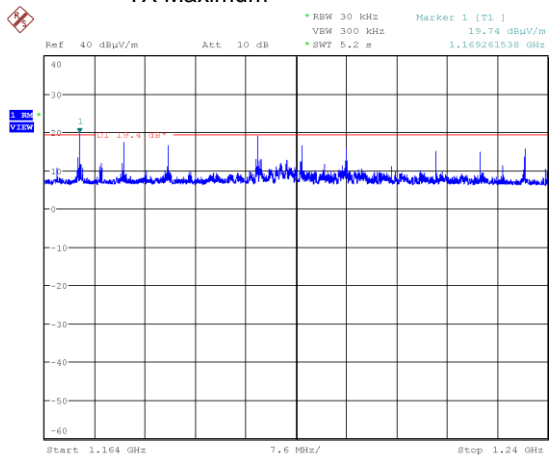

Date: 17.SEP.2018 07:04:30

Date: 17.SEP.2018 07:13:51

Note- the spurious emissions belong to the unintentional portion of transmitter



HERMON LABORATORIES

Test specification: Section 15.519(c),(d), Radiated spurious emissions			
Test procedure: ANSI C63.10-2013, sections 10.2, 10.3, Section 15.521			
Test mode: Compliance		Verdict: PASS	
Date(s): 25-Jun-18, 26-Jun-18			
Temperature: 24 °C	Relative Humidity: 48 %	Air Pressure: 1013 hPa	Power: Battery
Remarks:			

Plot 7.3.10 Radiated emission measurements in 1559 - 1610 MHz range according to the Section 15.519

TEST SITE:
ANTENNA POLARIZATION:
TEST DISTANCE:

Semi anechoic chamber
Vertical and Horizontal
1 m

TX Maximum
(turntable position -180 dgr)

TX attenuated by 40 dB
(turntable position -180 dgr)

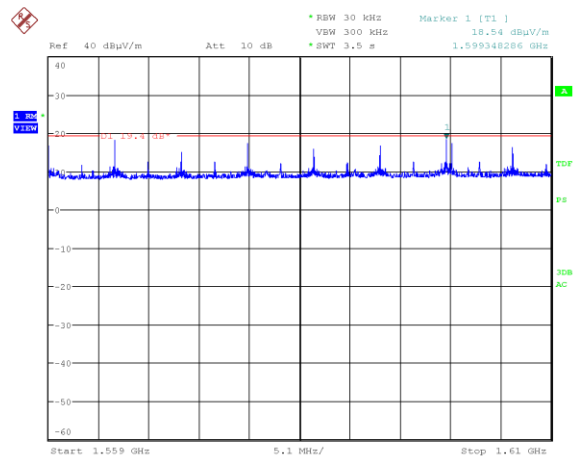
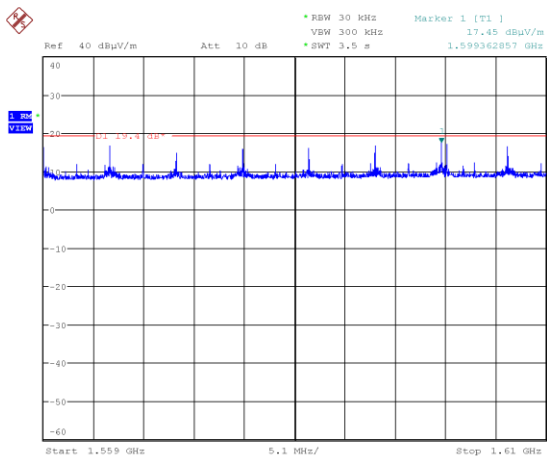

Date: 17.SEP.2018 07:56:55

Date: 17.SEP.2018 07:40:59

Note- the spurious emissions belong to the unintentional portion of transmitter

TX Maximum

TX attenuated by 40 dB

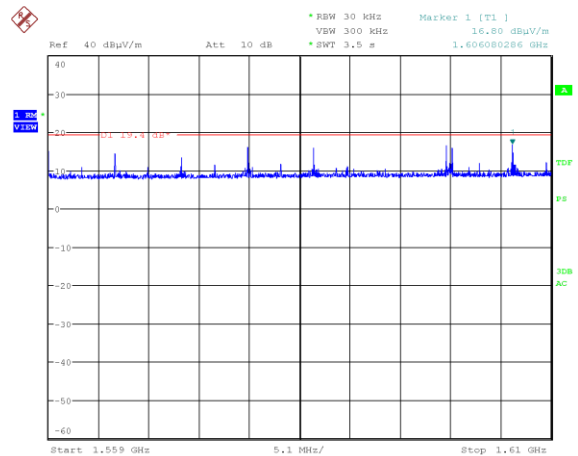
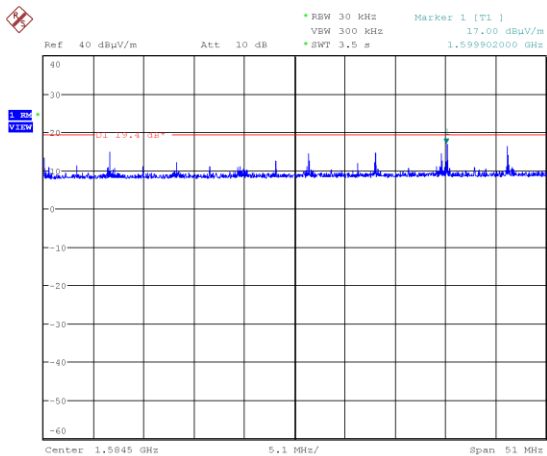

Date: 17.SEP.2018 06:57:06

Date: 17.SEP.2018 07:18:54

Note- the spurious emissions belong to the unintentional portion of transmitter



Test specification: Section 15.519(c),(d), Radiated spurious emissions			
Test procedure: ANSI C63.10-2013, sections 10.2, 10.3, Section 15.521			
Test mode: Compliance	Verdict: PASS		
Date(s): 25-Jun-18, 26-Jun-18			
Temperature: 24 °C	Relative Humidity: 48 %	Air Pressure: 1013 hPa	Power: Battery
Remarks:			

Plot 7.3.11 Radiated emission measurements in 1610 - 6000 MHz range according to the Section 15.519

TEST SITE: Semi anechoic chamber
ANTENNA POLARIZATION: Vertical and Horizontal
TEST DISTANCE: 3 m

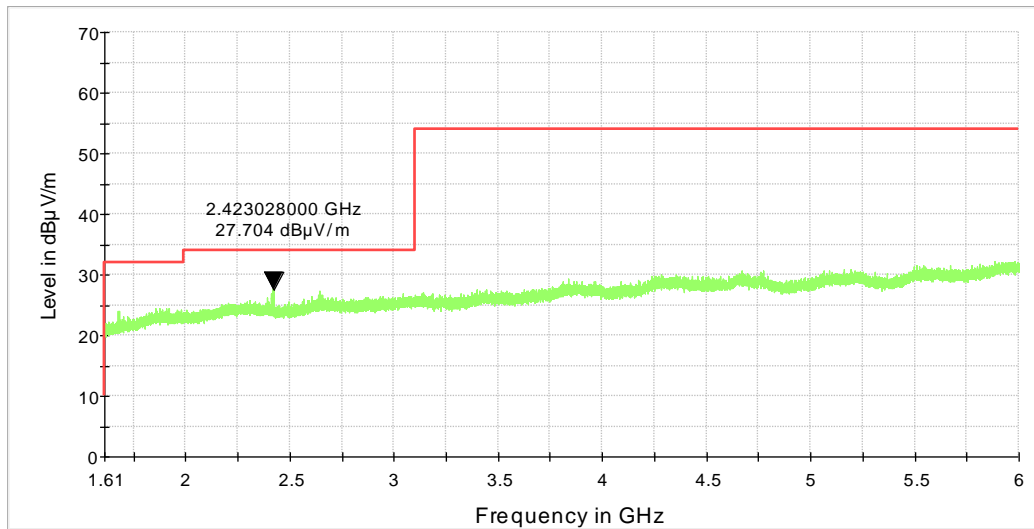

Plot 7.3.12 Radiated emission measurements in 8500 - 10600 MHz range according to the Section 15.519

TEST SITE: Semi anechoic chamber
ANTENNA POLARIZATION: Vertical and Horizontal
TEST DISTANCE: 3 m

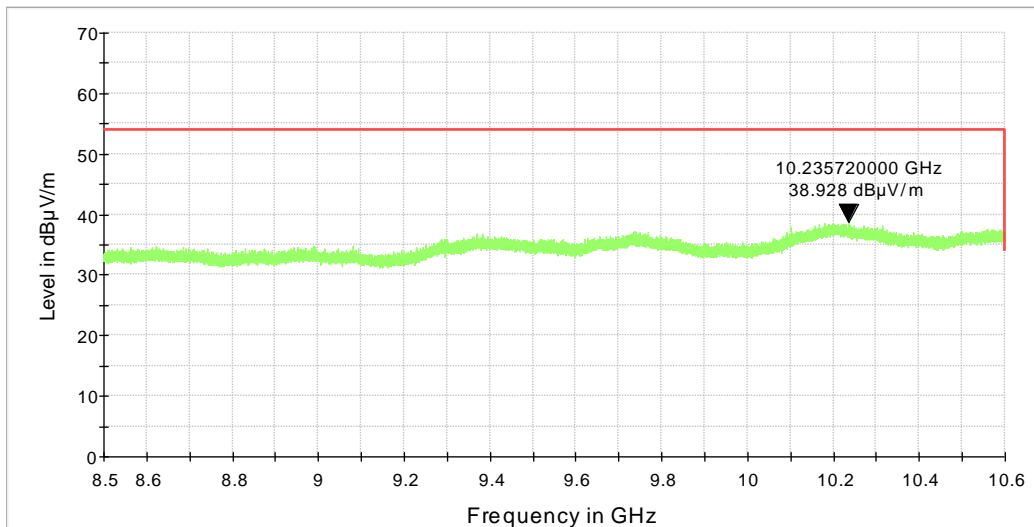



Test specification: Section 15.519(c),(d), Radiated spurious emissions			
Test procedure: ANSI C63.10-2013, sections 10.2, 10.3, Section 15.521			
Test mode: Compliance		Verdict: PASS	
Date(s): 25-Jun-18, 26-Jun-18			
Temperature: 24 °C	Relative Humidity: 48 %	Air Pressure: 1013 hPa	Power: Battery
Remarks:			

Plot 7.3.13 Radiated emission measurements in 10600 – 18000 MHz range according to the Section 15.519

TEST SITE:
ANTENNA POLARIZATION:
TEST DISTANCE:

Semi anechoic chamber
Vertical and Horizontal
1 m

TX Maximum
(turntable position -90 dgr)

TX attenuated by 40 dB
(turntable position -90 dgr)

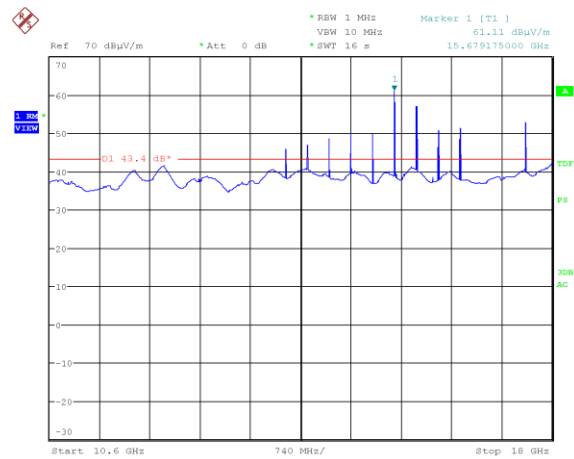
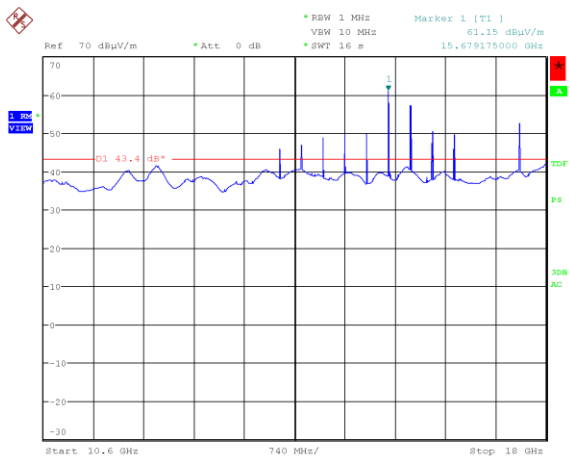

Date: 17.SEP.2018 09:35:34

Date: 17.SEP.2018 09:31:50

Note- the spurious emissions belong to the unintentional portion of transmitter

TX Maximum

TX attenuated by 40 dB

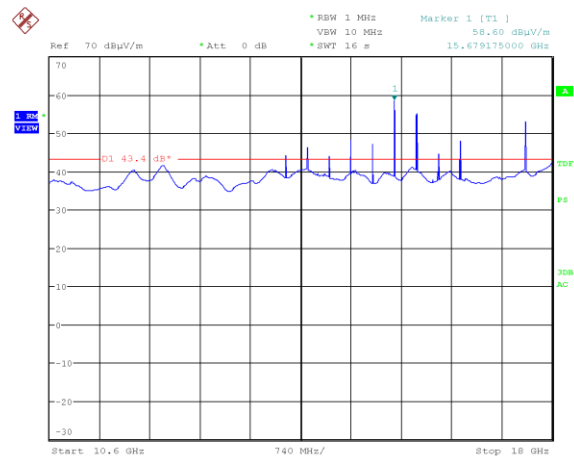
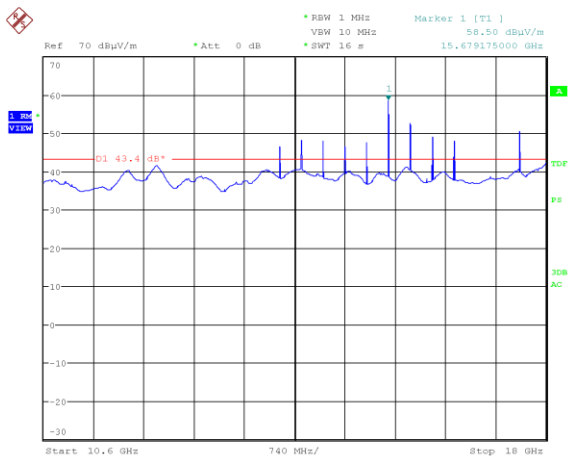

Date: 17.SEP.2018 09:38:53

Date: 17.SEP.2018 09:43:48

Note- the spurious emissions belong to the unintentional portion of transmitter



HERMON LABORATORIES

Test specification: Section 15.519(c),(d), Radiated spurious emissions			
Test procedure: ANSI C63.10-2013, sections 10.2, 10.3, Section 15.521			
Test mode: Compliance		Verdict: PASS	
Date(s): 25-Jun-18, 26-Jun-18			
Temperature: 24 °C	Relative Humidity: 48 %	Air Pressure: 1013 hPa	Power: Battery
Remarks:			

Plot 7.3.14 Radiated emission measurements in 18000 –26000 MHz range according to the Section 15.519

TEST SITE:
ANTENNA POLARIZATION:
TEST DISTANCE:

Semi anechoic chamber
Vertical and Horizontal
1 m

TX Maximum

TX attenuated by 40 dB

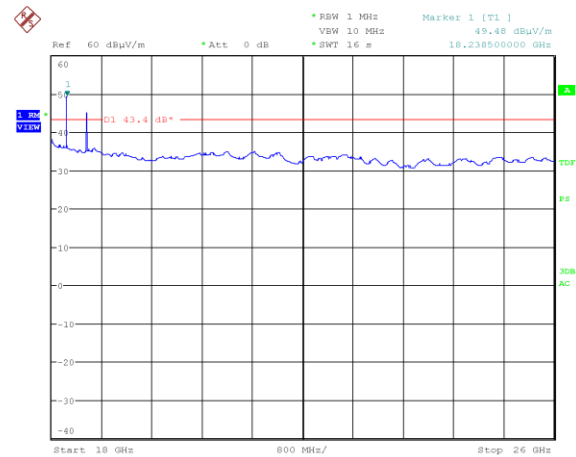
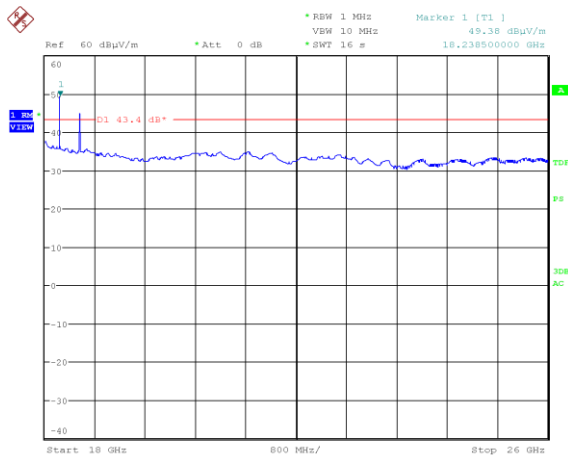

Date: 17.SEP.2018 10:43:15

Date: 17.SEP.2018 10:46:25

Note- the spurious emissions belong to the unintentional portion of transmitter

Plot 7.3.15 Radiated emission measurements in 26000 - 30000 MHz range

TEST SITE:
ANTENNA POLARIZATION:
TEST DISTANCE:

Semi anechoic chamber
Vertical and Horizontal
1 m

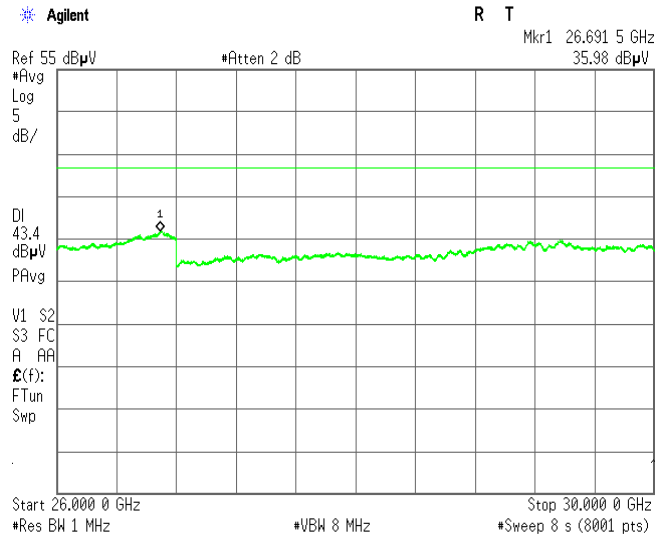



HERMON LABORATORIES

Test specification: Section 15.519(c),(d), Radiated spurious emissions			
Test procedure: ANSI C63.10-2013, sections 10.2, 10.3, Section 15.521			
Test mode: Compliance		Verdict: PASS	
Date(s): 25-Jun-18, 26-Jun-18			
Temperature: 24 °C	Relative Humidity: 48 %	Air Pressure: 1013 hPa	Power: Battery
Remarks:			

Plot 7.3.16 Radiated emission measurements in 30000 - 34000 MHz range

TEST SITE: Semi anechoic chamber
ANTENNA POLARIZATION: Vertical and Horizontal
TEST DISTANCE: 1 m

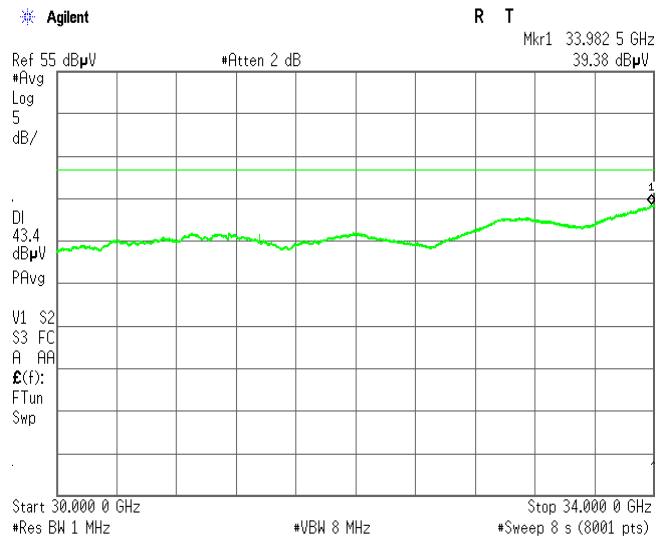

Plot 7.3.17 Radiated emission measurements in 34000 - 38000 MHz range

TEST SITE: Semi anechoic chamber
ANTENNA POLARIZATION: Vertical and Horizontal
TEST DISTANCE: 1 m

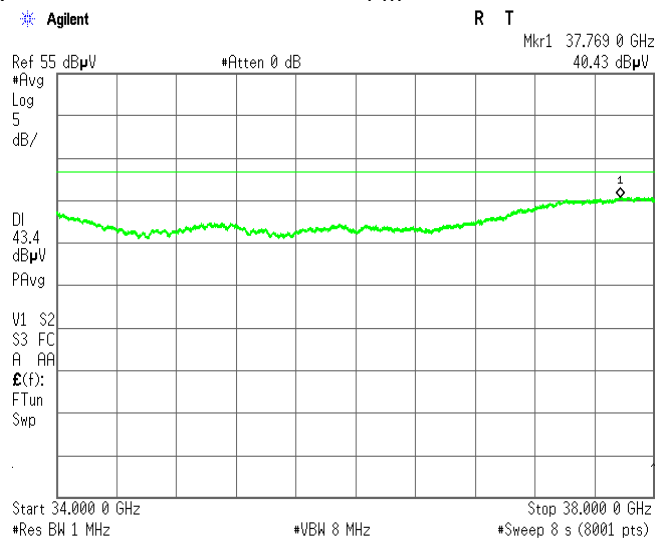



HERMON LABORATORIES

Test specification: Section 15.519(c),(d), Radiated spurious emissions			
Test procedure: ANSI C63.10-2013, sections 10.2, 10.3, Section 15.521			
Test mode: Compliance		Verdict: PASS	
Date(s): 25-Jun-18, 26-Jun-18			
Temperature: 24 °C	Relative Humidity: 48 %	Air Pressure: 1013 hPa	Power: Battery
Remarks:			

Plot 7.3.18 Radiated emission measurements in 38000 - 40000 MHz range

TEST SITE:
ANTENNA POLARIZATION:
TEST DISTANCE:

Semi anechoic chamber
Vertical and Horizontal
1 m

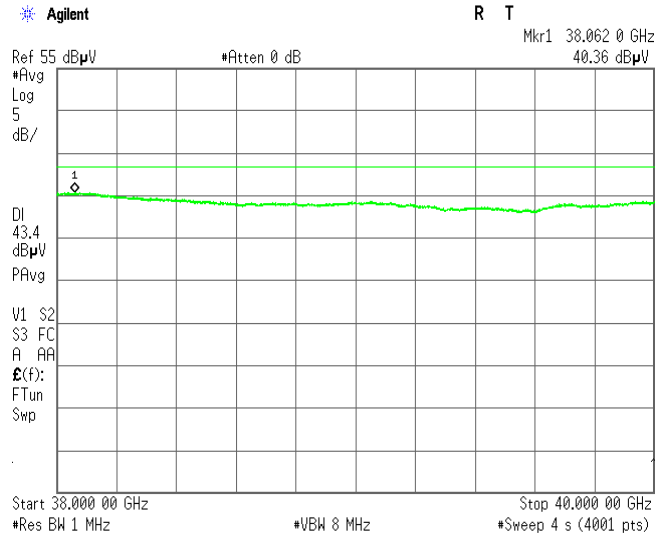



Test specification:	Section 15.519(a)(1), RSS-220 section 5.3.1(b), Transmission duration requirements		
Test procedure:	47 CFR, Section 15.521		
Test mode:	Compliance	Verdict:	PASS
Date(s):	23-Aug-16		
Temperature: 23 °C	Relative Humidity: 56 %	Air Pressure: 1007 hPa	Power Supply: Battery
Remarks:			

7.4 Transmission duration requirements

7.4.1 General

The EUT was verified for compliance with transmission duration requirements listed below:

- A transmitter shall cease transmission within 10 seconds unless it receives an acknowledgement from the associated receiver that its transmission was received.

7.4.2 Test procedure for transmitter shut down test

7.4.2.1 The EUT was set up as shown in Figure 7.4.1.

7.4.2.2 The spectrum analyzer center frequency was adjusted to the EUT carrier, span set to zero and video triggered for transmission.

7.4.2.3 The transmitter was triggered once by the host.

7.4.2.4 The transmission time was captured and shown in the associated plots. The test results for cease of transmitter operating is shown in Plot 7.4.1.

Figure 7.4.1 Setup for transmitter shut down test

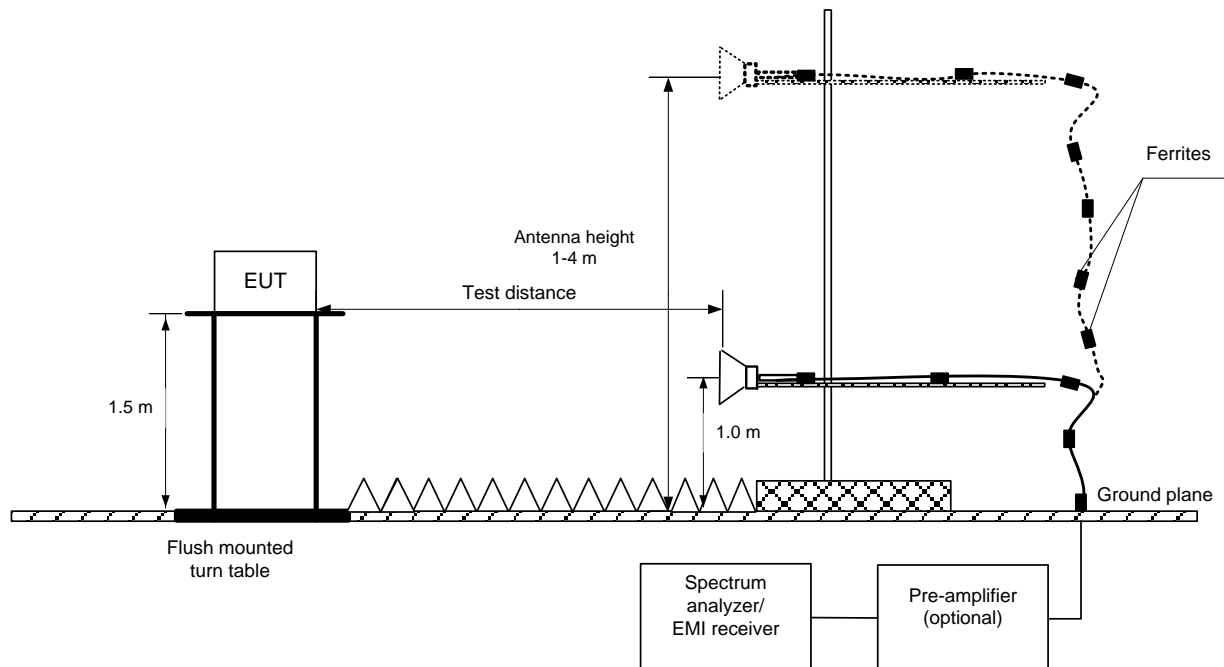

Reference numbers of test equipment used

HL 3903	HL 4360	HL 4933					
---------	---------	---------	--	--	--	--	--

Full description is given in Appendix A.



HERMON LABORATORIES

Test specification:	Section 15.519(a)(1), RSS-220 section 5.3.1(b), Transmission duration requirements		
Test procedure:	47 CFR, Section 15.521		
Test mode:	Compliance	Verdict: PASS	
Date(s):	23-Aug-16		
Temperature: 23 °C	Relative Humidity: 56 %	Air Pressure: 1007 hPa	Power Supply: Battery
Remarks:			

Plot 7.4.1 RF transmission duration in 12 sec period

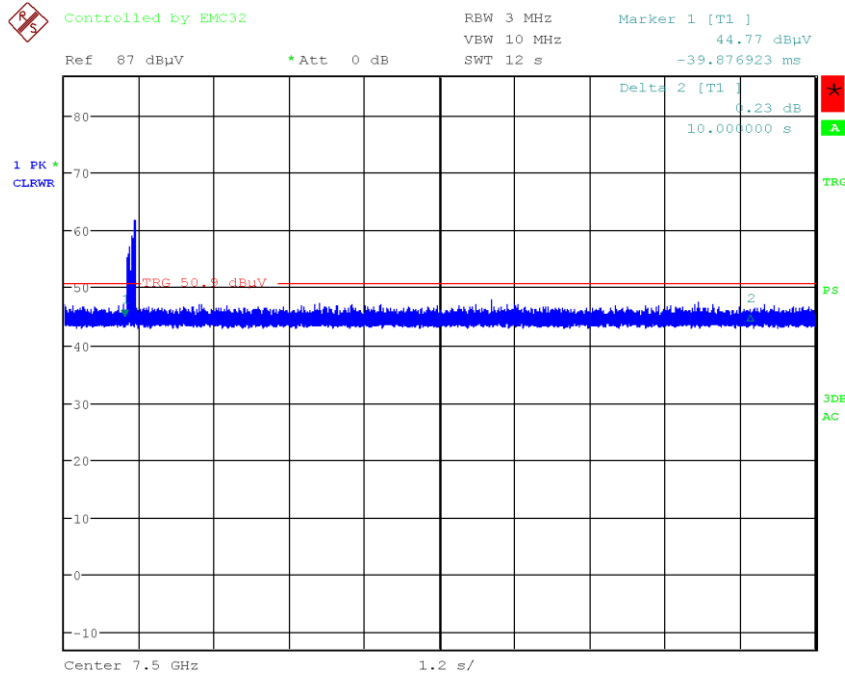

Date: 2.SEP.2018 05:33:18



Test specification: Section 15.207(a), Conducted emission			
Test procedure: ANSI C63.10, section 6.2			
Test mode: Compliance		Verdict: PASS	
Date(s): 03-Sep-18			
Temperature: 25 °C	Relative Humidity: 51 %	Air Pressure: 1007 hPa	Power: 120 VAC
Remarks:			

7.5 Conducted emissions

7.5.1 General

This test was performed to measure common mode conducted emissions at the power port. Specification test limits are given in Table 7.5.1.

Table 7.5.1 Limits for conducted emissions

Frequency, MHz	Class B limit, dB(μV)	
	QP	AVRG
0.15 - 0.5	66 - 56*	56 - 46*
0.5 - 5.0	56	46
5.0 - 30	60	50

* The limit decreases linearly with the logarithm of frequency.

7.5.2 Test procedure

7.5.2.1 The EUT was set up as shown in Figure 7.5.1 and associated photographs, energized and the performance check was conducted. The EUT was tested with a host device for example connected to a AC power supply.

7.5.2.2 The measurements were performed at power terminals with the LISN, connected to a spectrum analyzer in the frequency range referred to in Table 7.5.2. Unused coaxial connector of the LISN was terminated with 50 Ohm. Quasi-peak and average detectors were used throughout the testing.

7.5.2.3 The position of the device cables was varied to determine maximum emission level.

7.5.2.4 The worst test results (the lowest margins) were recorded in Table 7.5.2 and shown in the associated plots.

Figure 7.5.1 Setup for conducted emission measurements, table-top equipment

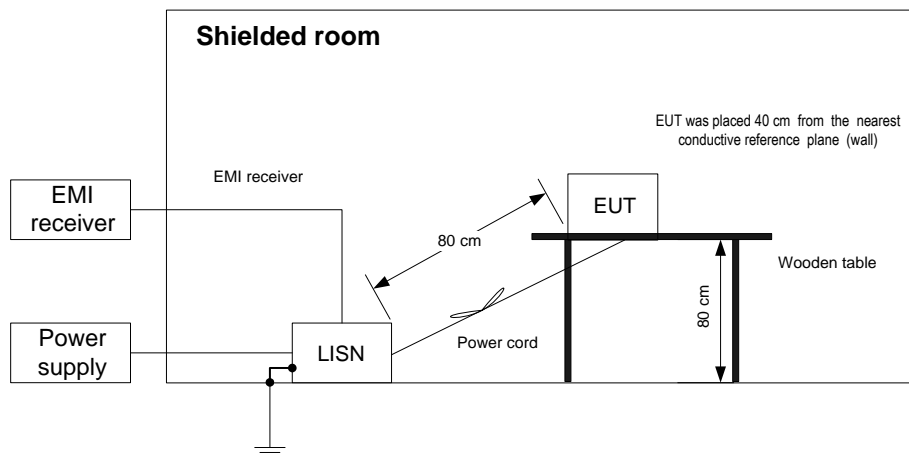



Test specification: Section 15.207(a), Conducted emission			
Test procedure: ANSI C63.10, section 6.2			
Test mode: Compliance		Verdict: PASS	
Date(s): 03-Sep-18			
Temperature: 25 °C	Relative Humidity: 51 %	Air Pressure: 1007 hPa	Power: 120 VAC
Remarks:			

Table 7.5.2 Conducted emission test results

LINE: AC mains
 EUT OPERATING MODE: Transmit
 EUT SET UP: TABLE-TOP
 TEST SITE: SHIELDED ROOM
 DETECTORS USED: PEAK / QUASI-PEAK / AVERAGE
 FREQUENCY RANGE: 150 kHz - 30 MHz
 RESOLUTION BANDWIDTH: 9 kHz

Frequency, MHz	Peak emission, dB(µV)	Quasi-peak			Average			Line ID	Verdict
		Measured emission, dB(µV)	Limit, dB(µV)	Margin, dB*	Measured emission, dB(µV)	Limit, dB(µV)	Margin, dB*		
0.157	59.7	55.6	65.6	-10.0	37.4	55.6	-18.2	L1	Pass
0.169	59.0	55.7	65.1	-9.4	38.7	55.1	-16.4		
0.184	57.7	52.1	64.4	-12.3	34.4	54.4	-20.0		
0.215	51.3	48.0	63.1	-15.1	29.7	53.1	-23.4		
0.498	36.0	29.1	56.0	-26.9	17.1	46.0	-28.9		
15.970	36.1	31.2	60.0	-28.8	24.1	50.0	-25.9		
0.152	60.3	54.9	65.9	-11.0	31.7	55.9	-24.2	L2	Pass
0.163	59.4	56.7	65.4	-8.7	39.4	55.4	-16.0		
0.188	57.8	51.8	64.1	-12.3	31.3	54.1	-22.8		
0.210	52.4	47.8	63.3	-15.5	30.3	53.3	-23.0		
1.524	33.4	29.1	56.0	-26.9	22.3	46.0	-23.7		
16.028	37.3	31.9	60.0	-28.1	24.5	50.0	-25.5		

*- Margin = Measured emission - specification limit.

Reference numbers of test equipment used

HL 0787	HL 1500	HL 3016	HL 4778				
---------	---------	---------	---------	--	--	--	--

Full description is given in Appendix A.



Test specification: Section 15.207(a), Conducted emission			
Test procedure: ANSI C63.10, section 6.2			
Test mode: Compliance		Verdict: PASS	
Date(s): 03-Sep-18			
Temperature: 25 °C	Relative Humidity: 51 %	Air Pressure: 1007 hPa	Power: 120 VAC
Remarks:			

Plot 7.5.1 Conducted emission measurements

LINE: L1
EUT OPERATING MODE: Transmit
LIMIT: QUASI-PEAK, AVERAGE
DETECTOR: PEAK



ACTV DET: PEAK
MERS DET: PEAK OP AVG
NKR 160 kHz
59.52 dBµV

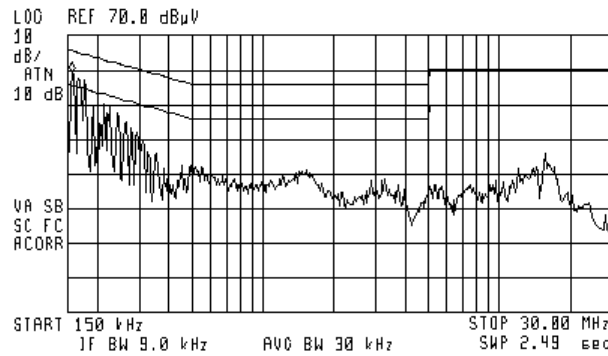

Plot 7.5.2 Conducted emission measurements

LINE: L2
EUT OPERATING MODE: Transmit
LIMIT: QUASI-PEAK, AVERAGE
DETECTOR: PEAK



ACTV DET: PEAK
MERS DET: PEAK OP AVG
NKR 150 kHz
59.16 dBµV

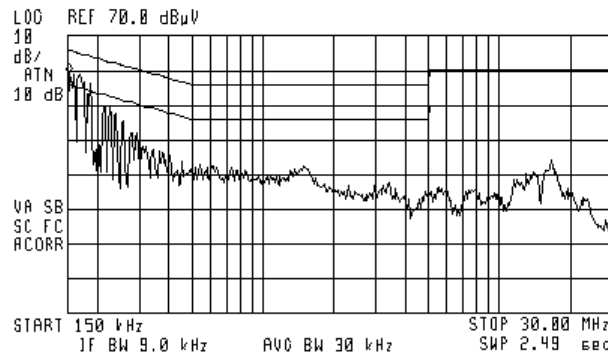



Test specification: Section 15.107, Conducted emission at AC power port			
Test procedure: ANSI C63.4, Sections 11.5 and 12.1.3			
Test mode: Compliance		Verdict: PASS	
Date(s): 03-Sep-18			
Temperature: 25 °C	Relative Humidity: 51 %	Air Pressure: 1007 hPa	Power: 120 VAC
Remarks:			

8 Unintentional emissions

8.1 Conducted emissions

8.1.1 General

This test was performed to measure common mode conducted emissions at the mains power port. Specification test limits are given in Table 8.1.1.

Table 8.1.1 Limits for conducted emissions a

Frequency, MHz	Class B limit, dB(µV)		Class A limit, dB(µV)	
	QP	AVRG	QP	AVRG
0.15 - 0.5	66 - 56*	56 - 46*	79	66
0.5 - 5.0	56	46	73	60
5.0 - 30	60	50	73	60

* - The limit decreases linearly with the logarithm of frequency.

8.1.2 Test procedure

8.1.2.1 The EUT was set up as shown in Figure 8.1.1 and associated photographs, energized and the performance check was conducted. The EUT was tested with a host device for example connected to a AC power supply.

8.1.2.2 The measurements were performed at power terminals with the LISN, connected to a spectrum analyzer while unused coaxial connector of the LISN was terminated with 50 Ohm.

8.1.2.3 The position of the device cables was varied to determine maximum emission level.

8.1.2.4 The worst test results (the lowest margins) were recorded in Table 8.1.2 and shown in the associated plots.



Test specification: Section 15.107, Conducted emission at AC power port			
Test procedure: ANSI C63.4, Sections 11.5 and 12.1.3			
Test mode: Compliance		Verdict: PASS	
Date(s): 03-Sep-18			
Temperature: 25 °C	Relative Humidity: 51 %	Air Pressure: 1007 hPa	Power: 120 VAC
Remarks:			

Figure 8.1.1 Setup for conducted emission measurements, table-top equipment

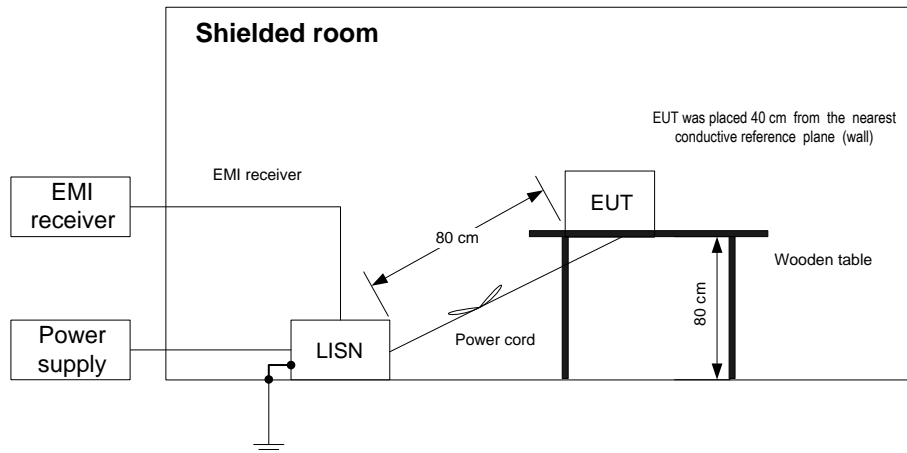

Photograph 8.1.1 Setup for conducted emission measurements

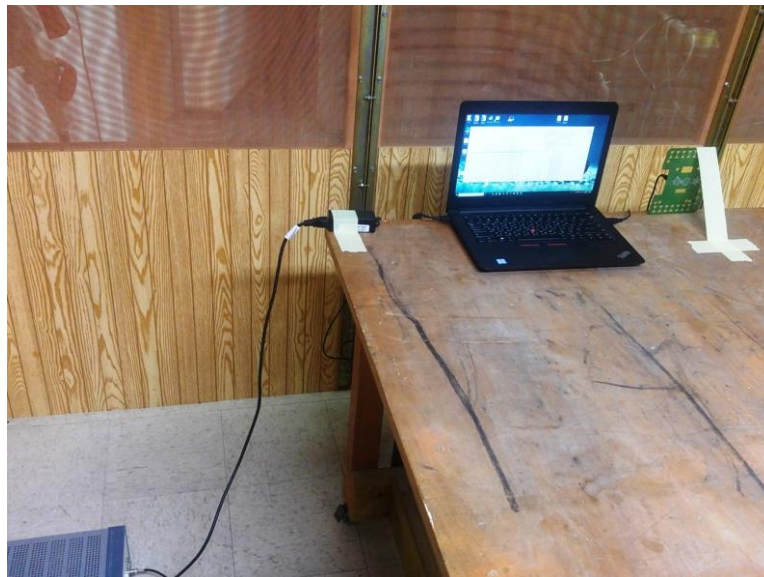



Test specification: Section 15.107, Conducted emission at AC power port			
Test procedure: ANSI C63.4, Sections 11.5 and 12.1.3			
Test mode: Compliance		Verdict: PASS	
Date(s): 03-Sep-18			
Temperature: 25 °C	Relative Humidity: 51 %	Air Pressure: 1007 hPa	Power: 120 VAC
Remarks:			

Table 8.1.2 Conducted emission test results

LINE: AC mains
 EUT OPERATING MODE: Stand-by and receive
 EUT SET UP: TABLE-TOP
 TEST SITE: SHIELDED ROOM
 FREQUENCY RANGE: 150 kHz - 30 MHz
 RESOLUTION BANDWIDTH: 9 kHz

Frequency, MHz	Peak emission, dB(µV)	Quasi-peak			Average			Line ID	Verdict
		Measured emission, dB(µV)	Limit, dB(µV)	Margin, dB*	Measured emission, dB(µV)	Limit, dB(µV)	Margin, dB*		
0.169	60.2	57.1	65.1	-8.0	41.3	55.1	-13.8	L1	Pass
0.182	57.3	54.2	64.4	-10.2	34.5	54.4	-19.9		
0.209	51.8	49.7	63.3	-13.6	33.0	53.3	-20.3		
0.260	45.3	42.6	61.5	-18.9	23.7	51.5	-27.8		
0.518	36.7	29.3	56.0	-26.7	13.2	46.0	-32.8		
15.980	40.5	34.4	60.0	-25.6	26.8	50.0	-23.2		
0.150	58.2	56.8	66.0	-9.2	39.7	56.0	-16.3	L2	Pass
0.185	54.7	51.3	64.2	-12.9	29.2	54.2	-25.0		
0.201	49.6	47.5	63.6	-16.1	30.3	53.6	-23.3		
0.230	46.9	42.8	62.5	-19.7	22.8	52.5	-29.7		
1.456	31.7	28.2	56.0	-27.8	21.9	46.0	-24.1		
15.963	33.7	28.1	60.0	-31.9	22.1	50.0	-27.9		

*- Margin = Measured emission - specification limit.

Reference numbers of test equipment used

HL 0787	HL 1500	HL 3016	HL 4778				
---------	---------	---------	---------	--	--	--	--

Full description is given in Appendix A.



Test specification: Section 15.107, Conducted emission at AC power port			
Test procedure: ANSI C63.4, Sections 11.5 and 12.1.3			
Test mode: Compliance		Verdict: PASS	
Date(s): 03-Sep-18			
Temperature: 25 °C	Relative Humidity: 51 %	Air Pressure: 1007 hPa	Power: 120 VAC
Remarks:			

Plot 8.1.1 Conducted emission measurements

LINE: L1
 LIMIT: Class B
 EUT OPERATING MODE: Stand-by
 LIMIT: QUASI-PEAK, AVERAGE
 DETECTOR: PEAK



ACTV DET: PEAK
 MERS DET: PEAK QP AVG
 NKR 170 kHz
 59.14 dBµV

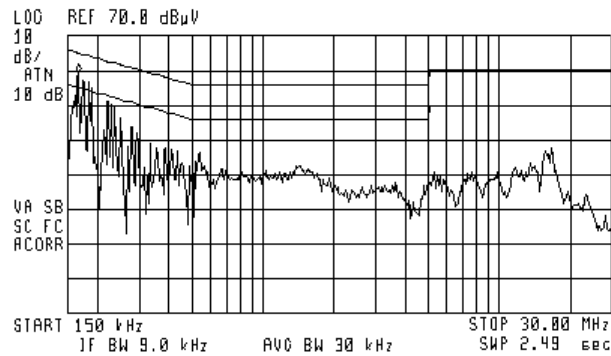

Plot 8.1.2 Conducted emission measurements

LINE: L2
 LIMIT: Class B
 EUT OPERATING MODE: Stand-by
 LIMIT: QUASI-PEAK, AVERAGE
 DETECTOR: PEAK



ACTV DET: PEAK
 MERS DET: PEAK QP AVG
 NKR 150 kHz
 56.98 dBµV

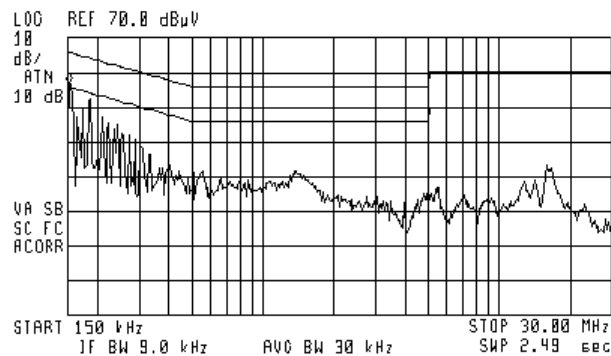



Test specification: Section 15.109, Radiated emission			
Test procedure: ANSI C63.4, Sections 11.6 and 12.1.4			
Test mode: Compliance		Verdict: PASS	
Date(s): 03-Sep-18			
Temperature: 24 °C	Relative Humidity: 49 %	Air Pressure: 1008 hPa	Power: 5 VDC
Remarks:			

8.2 Radiated emission measurements

8.2.1 General

This test was performed to measure radiated emissions from the EUT enclosure. Specification test limits are given in Table 8.2.1.

Table 8.2.1 Radiated emission limits

Frequency, MHz	Class B limit, dB(μV/m)		Class A limit, dB(μV/m)	
	10 m distance	3 m distance	10 m distance	3 m distance
30 - 88	29.5*	40.0	39.0	49.5*
88 - 216	33.0*	43.5	43.5	54.0*
216 - 960	35.5*	46.0	46.4	56.9*
960 - 5 th harmonic**	43.5*	54.0	49.5	60.0*

* - The limit for test distance other than specified was calculated using the inverse linear distance extrapolation factor as follows:

$$\text{Lim}_{S_2} = \text{Lim}_{S_1} + 20 \log (S_1/S_2),$$

where S_1 and S_2 – standard defined and test distance respectively in meters.

8.2.2 Test procedure

- 8.2.2.1** The EUT was set up as shown in Figure 8.2.1 and associated photograph/s, energized and the performance check was conducted.
- 8.2.2.2** The specified frequency range was investigated with biconilog antenna connected to EMI receiver. To find maximum radiation the turntable was rotated 360°, the measuring antenna height was changed from 1 to 4 m, its polarization was switched from vertical to horizontal and the EUT cables position was varied.
- 8.2.2.3** The worst test results (the lowest margins) were provided in the associated tables and plots.



Test specification: Section 15.109, Radiated emission			
Test procedure: ANSI C63.4, Sections 11.6 and 12.1.4			
Test mode: Compliance	Verdict: PASS		
Date(s): 03-Sep-18			
Temperature: 24 °C	Relative Humidity: 49 %	Air Pressure: 1008 hPa	Power: 5 VDC
Remarks:			

Figure 8.2.1 Setup for radiated emission measurements, table-top equipment

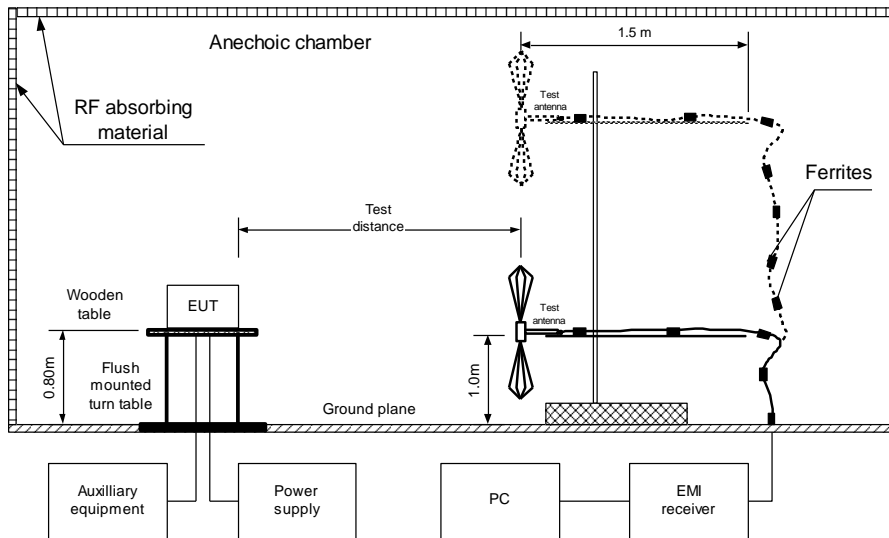

Photograph 8.2.1 Setup for radiated emission measurements

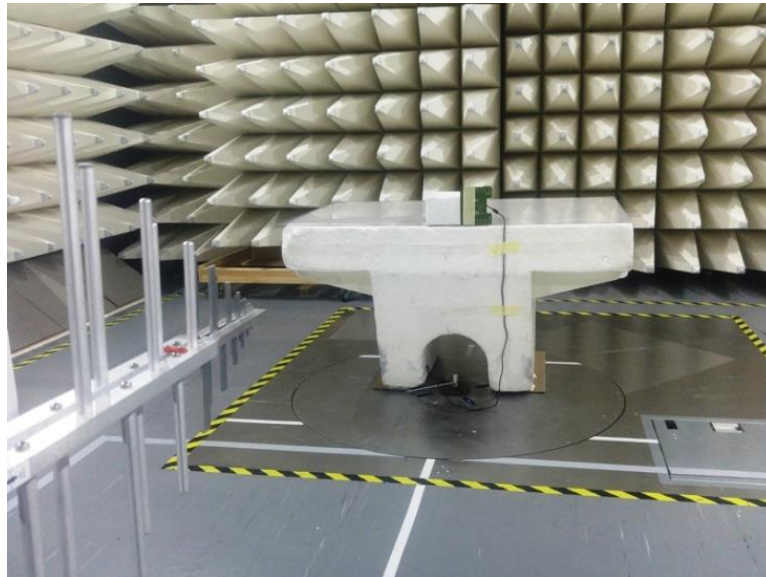



Test specification: Section 15.109, Radiated emission			
Test procedure: ANSI C63.4, Sections 11.6 and 12.1.4			
Test mode: Compliance		Verdict: PASS	
Date(s): 03-Sep-18			
Temperature: 24 °C	Relative Humidity: 49 %	Air Pressure: 1008 hPa	Power: 5 VDC
Remarks:			

Photograph 8.2.2 Setup for radiated emission measurements

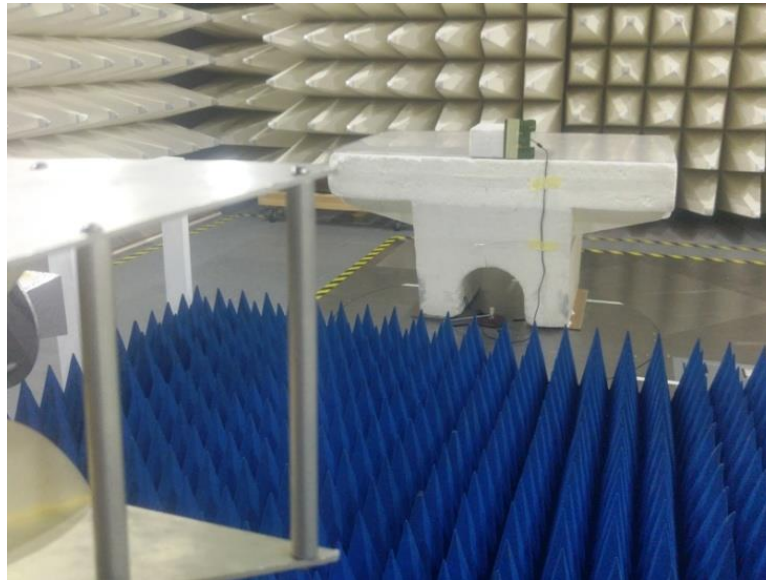

Photograph 8.2.3 Setup for radiated emission measurements, EUT cabling

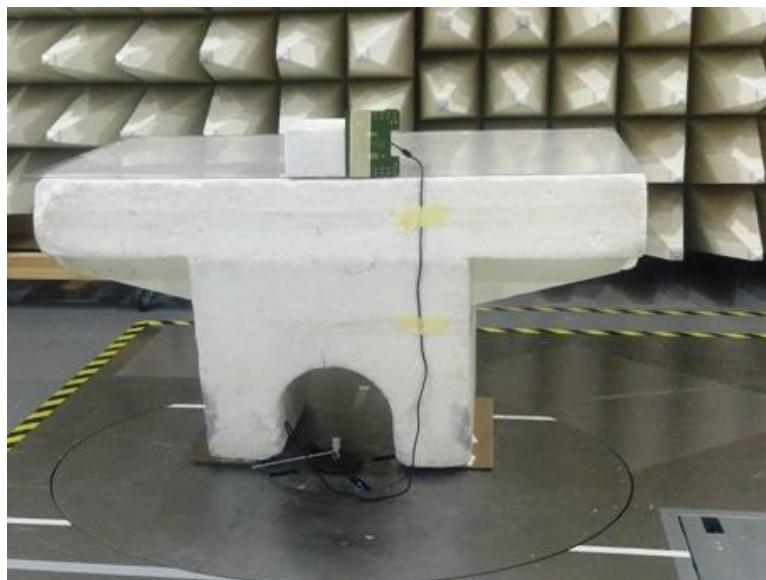



Test specification: Section 15.109, Radiated emission			
Test procedure: ANSI C63.4, Sections 11.6 and 12.1.4			
Test mode: Compliance		Verdict: PASS	
Date(s): 03-Sep-18			
Temperature: 24 °C	Relative Humidity: 49 %	Air Pressure: 1008 hPa	Power: 5 VDC
Remarks:			

Table 8.2.2 Radiated emission test results

EUT SET UP: TABLE-TOP
LIMIT: Class B
EUT OPERATING MODE: Stand-by
TEST SITE: SEMI ANECHOIC CHAMBER
TEST DISTANCE: 3 m
FREQUENCY RANGE: 30 MHz – 1000 MHz
RESOLUTION BANDWIDTH: 120 kHz

Frequency, MHz	Peak emission, dB(µV/m)	Quasi-peak			Antenna polarization	Antenna height, m	Turn-table position**, degrees	Verdict
		Measured emission, dB(µV/m)	Limit, dB(µV/m)	Margin, dB*				
No emissions were found								Pass

TEST SITE: SEMI ANECHOIC CHAMBER
TEST DISTANCE: 3 m
DETECTORS USED: PEAK / AVERAGE
FREQUENCY RANGE: 1000 MHz – 40 000 MHz
RESOLUTION BANDWIDTH: 1000 kHz

Frequency, MHz	Peak			Average			Antenna polarization	Antenna height, m	Turn-table position**, degrees	Verdict
	Measured emission, dB(µV/m)	Limit, dB(µV/m)	Margin, dB*	Measured emission, dB(µV/m)	Limit, dB(µV/m)	Margin, dB*				
No emissions were found										Pass

Reference numbers of test equipment used

HL 3903	HL 4360	HL 4933	HL 5405	HL 5288			
---------	---------	---------	---------	---------	--	--	--

Full description is given in Appendix A.



Test specification: Section 15.109, Radiated emission			
Test procedure: ANSI C63.4, Sections 11.6 and 12.1.4			
Test mode: Compliance		Verdict: PASS	
Date(s): 03-Sep-18			
Temperature: 24 °C	Relative Humidity: 49 %	Air Pressure: 1008 hPa	Power: 5 VDC
Remarks:			

Plot 8.2.1 Radiated emission measurements in 30 - 1000 MHz range, vertical and horizontal antenna polarization

TEST SITE: Semi anechoic chamber
LIMIT: Class B
TEST DISTANCE: 3 m
EUT OPERATING MODE: Stand-by

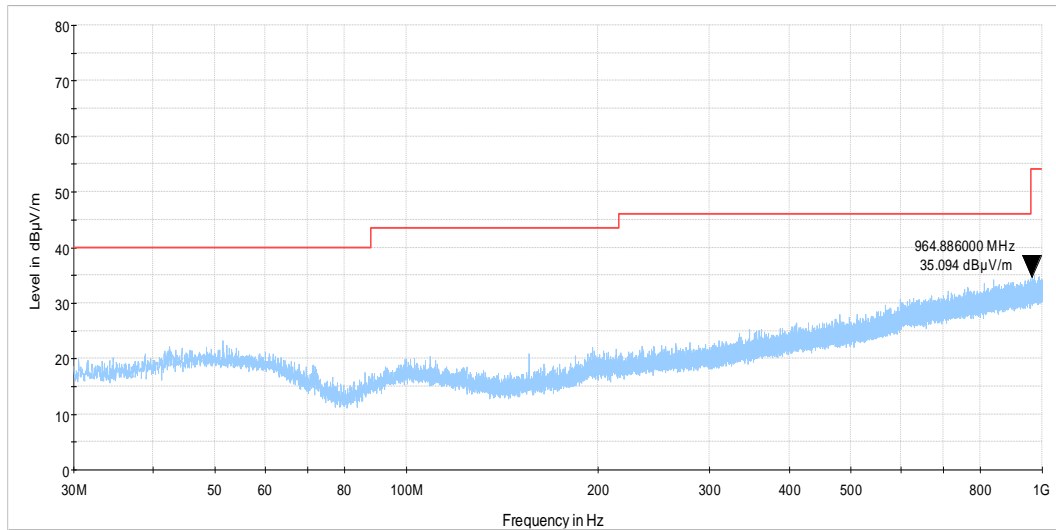

Plot 8.2.2 Radiated emission measurements in 1 – 18 GHz range, vertical and horizontal antenna polarization

TEST SITE: Semi anechoic chamber
LIMIT: Class B
TEST DISTANCE: 3 m
EUT OPERATING MODE: Stand-by

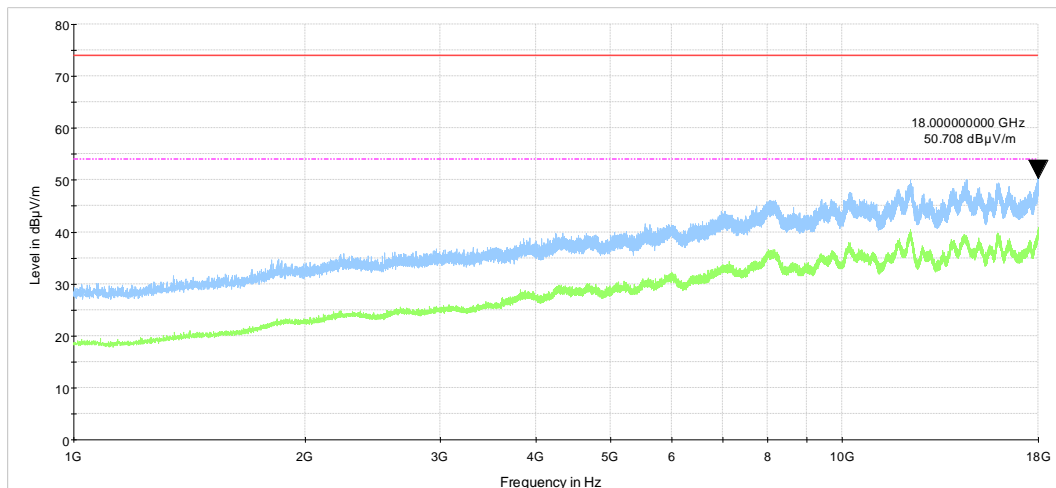



HERMON LABORATORIES

Test specification: Section 15.109, Radiated emission			
Test procedure: ANSI C63.4, Sections 11.6 and 12.1.4			
Test mode: Compliance		Verdict: PASS	
Date(s): 03-Sep-18			
Temperature: 24 °C	Relative Humidity: 49 %	Air Pressure: 1008 hPa	Power: 5 VDC
Remarks:			

Plot 8.2.3 Radiated emission measurements in 18 - 40 GHz range, vertical and horizontal antenna polarization

TEST SITE:

LIMIT:

TEST DISTANCE:

EUT OPERATING MODE:

Semi anechoic chamber

Class B

3 m

Stand-by

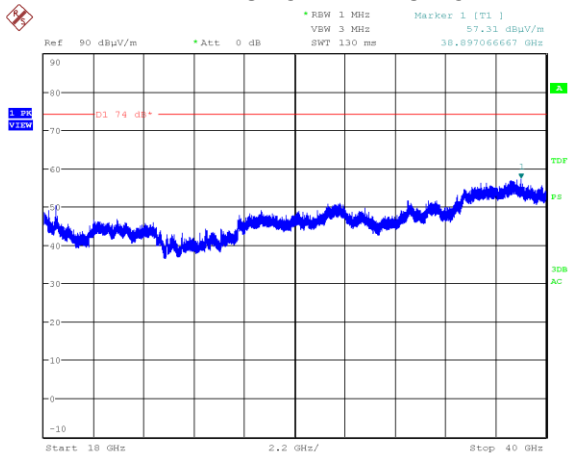

Date: 2.SEP.2018 10:09:27

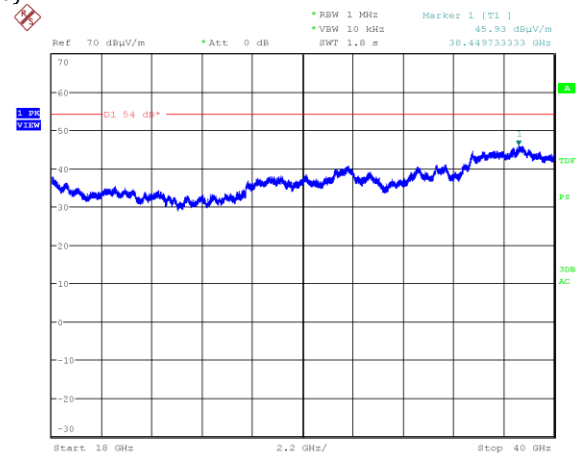

Date: 2.SEP.2018 10:14:24

**9 APPENDIX A Test equipment and ancillaries used for tests**

HL No	Description	Manufacturer	Model	Ser. No.	Last Cal./ Check	Due Cal./ Check
0034	Antenna, Log Periodic, 200 - 1000 MHz	Electro-Metrics	LPA 25/30	1988	31-May-18	31-May-19
0446	Antenna, Loop, Active, 10 kHz - 30 MHz	EMCO	6502	2857	11-Feb-18	11-Feb-19
3615	Cable RF, 6.5 m, N type-N type, DC-6 GHz	Suhner Switzerland	RG 214/U	NA	10-Jun-18	10-Jun-19
3818	PSA Series Spectrum Analyzer, 3 Hz- 44 GHz	Agilent Technologies	E4446A	MY48250288	28-May-18	28-May-19
3903	Microwave Cable Assembly, 40.0 GHz, 1.5 m, SMA/SMA	Huber-Suhner	SUCOFLEX 102A	1226/2A	07-Feb-18	07-Feb-19
4277	Test Cable , DC-18 GHz, 3.05 m, N/M - N/M	Mini-Circuits	APC-10FT-NMNM+	0748A	01-Aug-18	01-Aug-19
4355	Signal and Spectrum Analyzer, 9 kHz to 7 GHz	Rohde & Schwarz	FSV 7	101630	28-Jun-18	28-Sep-19
4360	EMI Test Receiver, 20 Hz to 40 GHz	Rohde & Schwarz	ESU40	100322	26-Dec-17	26-Dec-18
4933	Active Horn Antenna, 1 GHz to 18 GHz	COM-POWER CORPORATION	AHA-118	701046	04-Jan-18	04-Jan-19
4956	Active horn antenna, 18 to 40 GHz	COM-POWER CORPORATION	AHA-840	105004	11-Jan-18	11-Jan-19
5111	RF cable, 40 GHz, 5.5 m, K-type	Huber-Suhner	SF102EA/11SK/11SK/500MM	502493/2EA	09-Apr-18	09-Apr-19
5288	Trilog Antenna, 25 MHz - 8 GHz, 100W	Frankonia	ALX-8000E	00809	21-Jan-18	21-Jan-19
5405	RF cable, 18 GHz, N-N, 6 m	Huber-Suhner	SF118/11N (x2)	500023/118	01-Aug-18	01-Aug-19



10 APPENDIX B Measurement uncertainties

Expanded uncertainty at 95% confidence in Hermon Labs EMC measurements

Test description	Expanded uncertainty
Conducted carrier power at RF antenna connector	Below 12.4 GHz: ± 1.7 dB 12.4 GHz to 40 GHz: ± 2.3 dB
Conducted emissions at RF antenna connector	9 kHz to 2.9 GHz: ± 2.6 dB 2.9 GHz to 6.46 GHz: ± 3.5 dB 6.46 GHz to 13.2 GHz: ± 4.3 dB 13.2 GHz to 22.0 GHz: ± 5.0 dB 22.0 GHz to 26.8 GHz: ± 5.5 dB 26.8 GHz to 40.0 GHz: ± 4.8 dB
Occupied bandwidth	± 8.0 %
Duty cycle, timing (Tx ON / OFF) and average factor measurements	± 1.0 %
Conducted emissions with LISN	9 kHz to 150 kHz: ± 3.9 dB 150 kHz to 30 MHz: ± 3.8 dB
Radiated emissions at 3 m measuring distance Horizontal polarization Vertical polarization	Biconilog antenna: ± 5.3 dB Biconical antenna: ± 5.0 dB Log periodic antenna: ± 5.3 dB Double ridged horn antenna: ± 5.3 dB Biconilog antenna: ± 6.0 dB Biconical antenna: ± 5.7 dB Log periodic antenna: ± 6.0 dB Double ridged horn antenna: ± 6.0 dB
Conducted emissions with LISN	9 kHz to 150 kHz: ± 3.9 dB 150 kHz to 30 MHz: ± 3.8 dB

Hermon Laboratories is accredited by A2LA for calibration according to present requirements of ISO/IEC 17025 and NCSL Z540-1. The accreditation is granted to perform calibration of parameters that are listed in the Scope of Hermon Laboratories Accreditation.

Hermon Laboratories calibrates its reference and transfer standards by calibration laboratories accredited to ISO/IEC 17025 by a mutually recognized Accreditation Body or by a recognized national metrology institute. All reference and transfer standards used in the calibration system are traceable to national or international standards.

In-house calibration of all test and measurement equipment is performed on a regular basis according to Hermon Laboratories calibration procedures, manufacturer calibration/verification procedures or procedures defined in the relevant standards. The Hermon Laboratories test and measurement equipment is calibrated within the tolerances specified by the manufacturers and/or by the relevant standards.

11 APPENDIX C Test laboratory description

Tests were performed at Hermon Laboratories Ltd., which is a fully independent, private, EMC, Radio, Safety, Environmental and Telecommunication testing facility.

Hermon Laboratories is recognized and accredited by the Federal Communications Commission (USA) for 1, 2, 15, 18 parts of Code of Federal Regulations 47 (CFR 47), Test Firm Registration Number is 927748, Designation Number is IL1001; registered by Industry Canada for electromagnetic emissions, file number IC 2186A-1 for OATS, certified by VCCI, Japan (the registration numbers are R-10808 for OATS, R-1082 for anechoic chamber, G-10869 for RE measurements above 1 GHz, C-10845 for conducted emissions site and T-11606 for conducted emissions at telecommunication ports).

The laboratory is accredited by American Association for Laboratory Accreditation (USA) according to ISO/IEC 17025 for electromagnetic compatibility, product safety, telecommunications testing, environmental simulation and calibration (for exact scope please refer to Certificate No. 839.01, 839.03 and 839.04).

Address: P.O. Box 23, Binyamina 30500, Israel.
Telephone: +972 4628 8001
Fax: +972 4628 8277
e-mail: mail@hermonlabs.com
website: www.hermonlabs.com

Person for contact: Mr. Michael Nikishin, EMC&Radio group manager.

12 APPENDIX D Specification references

FCC 47CFR part 15: 2017	Radio Frequency Devices
ANSI C63.10: 2013	American National Standard of Procedures for Compliance Testing of Unlicensed Wireless Devices
ANSI C63.2: 2016	American National Standard for Instrumentation-Electromagnetic Noise and Field Strength, 10 kHz to 40 GHz-Specifications
ANSI C63.4: 2014	American National Standard for Method of Measurement of Radio-Noise Emissions from Low-Voltage Electrical and Electronic Equipment in the Range of 9 kHz to 40 GHz



13 APPENDIX E Test equipment correction factors

Antenna factor
Active loop antenna
Model 6502, S/N 2857, HL 0446

Frequency, MHz	Magnetic antenna factor, dB	Electric antenna factor, dB
0.009	-32.8	18.7
0.010	-33.8	17.7
0.020	-38.3	13.2
0.050	-41.1	10.4
0.075	-41.3	10.2
0.100	-41.6	9.9
0.150	-41.7	9.8
0.250	-41.6	9.9
0.500	-41.8	9.8
0.750	-41.9	9.7
1.000	-41.4	10.1
2.000	-41.5	10.0
3.000	-41.4	10.2
4.000	-41.4	10.1
5.000	-41.5	10.1
10.000	-41.9	9.6
15.000	-41.9	9.6
20.000	-42.2	9.3
25.000	-42.8	8.7
30.000	-44.0	7.5

Antenna factor in dB(1/m) is to be added to receiver meter reading in dB(μ V) to convert it into field strength in dB(μ V/m).



Antenna factor
Log periodic antenna
Electro-Metrics, model LPA-25/30
Ser.No.1988, HL 0034

Frequency MHz	Antenna Factor dB(1/m)	Frequency MHz	Antenna Factor dB(1/m)
200	12.6	625	20.4
225	12.2	650	20.9
250	13.4	675	22.0
275	14.3	700	22.2
300	15.2	725	22.7
325	15.7	750	22.5
350	15.9	775	22.7
375	16.4	800	22.8
400	17.0	825	23.2
425	17.4	850	23.5
450	17.9	875	23.9
475	18.6	900	24.0
500	19.1	925	24.0
525	19.3	950	24.2
550	19.6	975	24.7
575	19.8	1000	25.1
600	20.0		

Antenna factor in dB(1/m) is to be added to receiver meter reading in dB(μ V) to convert it into field strength in dB(μ V/m).



Active Horn Antenna,
Com-Power Corporation, model: AHA-118, s/n 701046, HL 4933

Frequency, MHz	Measured antenna factor (with preamplifier), dB/m
1000	-16.1
1500	-15.1
2000	-10.9
2500	-11.9
3000	-11.1
3500	-10.6
4000	-8.6
4500	-8.3
5000	-5.9
5500	-5.7
6000	-3.3
6500	-4.0
7000	-2.2
7500	-1.7
8000	1.1
8500	-0.8
9000	-1.5
9500	-0.2

Frequency, MHz	Measured antenna factor (with preamplifier), dB/m
10000	1.8
10500	1.0
11000	0.3
11500	-0.5
12000	3.1
12500	1.4
13000	-0.3
13500	-0.4
14000	2.5
14500	2.2
15000	1.9
15500	0.5
16000	2.1
16500	1.2
17000	0.6
17500	3.1
18000	4.2

The antenna factor shall be added to receiver reading in dB μ V to obtain field strength in dB μ V/m.



Antenna factor, HL 4956



Active Horn Antenna Factor Calibration

18 GHz to 40 GHz

Equipment:	ACTIVE HORN ANTENNA
Model:	AHA-840
Serial Number:	105004
Calibration Distance:	3 meter
Polarization:	Horizontal
Calibration Date:	1/26/2015

Frequency (GHz)	Preamplifier Gain (dB)	Antenna Factor with pre-amp (dB/m)	Frequency (GHz)	Preamplifier Gain (dB)	Antenna Factor with pre-amp (dB/m)
18	38.83	-1.06	29.5	42.47	-5.33
18.5	39.34	-2.65	30	41.91	-4.86
19	39.71	-3.88	30.5	41.60	-4.64
19.5	39.87	-4.35	31	41.52	-4.60
20	39.98	-3.97	31.5	41.56	-4.79
20.5	40.42	-3.68	32	41.80	-5.21
21	41.12	-4.06	32.5	42.29	-5.54
21.5	41.74	-5.46	33	42.79	-5.63
22	42.14	-6.22	33.5	42.88	-5.38
22.5	42.35	-6.42	34	42.62	-4.76
23	42.50	-6.59	34.5	42.63	-4.84
23.5	42.65	-6.82	35	43.15	-5.13
24	42.81	-7.01	35.5	43.91	-5.83
24.5	42.86	-7.37	36	44.59	-6.39
25	42.73	-7.53	36.5	45.04	-6.64
25.5	42.77	-7.45	37	45.08	-6.40
26	42.85	-7.21	37.5	44.82	-5.75
26.5	42.98	-7.17	38	44.16	-4.58
27	43.14	-7.22	38.5	42.90	-2.66
27.5	43.18	-7.32	39	42.39	-1.71
28	43.04	-7.10	39.5	43.76	-2.49
28.5	43.01	-6.73	40	45.98	-5.21

Calibration per ANSI C63.5: 2006
Standard Site Method, Equations 1-6 (3-antenna)

Corrected Reading (dBμV/m) = Meter Reading (dBμV) + AFE(dB/m)

Antenna factor
Trilog antenna
Model ALX-8000E, Frankonia, S/N 00809, HL 5288, 30-1000 MHz

Frequency, MHz	Antenna factor, dB/m
30	14.96
35	15.33
40	16.37
45	17.56
50	17.95
60	16.87
70	13.22
80	10.56
90	13.61
100	15.46
120	14.03
140	12.23
160	12.67
180	13.34
200	15.40
250	16.42
300	17.28
400	19.98
500	21.11
600	22.90
700	24.13
800	25.25
900	26.35
1000	27.18

The antenna factor shall be added to receiver reading in dB μ V to obtain field strength in dB μ V/m.



Cable loss
Cable coaxial, RG-214/U, N type-N type, 6.5 m
Suhner Switzerland, HL 3615

Frequency, MHz	Cable loss, dB	Frequency, MHz	Cable loss, dB	Frequency, MHz	Cable loss, dB	Frequency, MHz	Cable loss, dB
10	0.13	1750	2.47	3550	4.10	5350	5.76
30	0.24	1800	2.53	3600	4.17	5400	5.84
50	0.31	1850	2.59	3650	4.21	5450	5.88
100	0.47	1900	2.61	3700	4.23	5500	5.90
150	0.58	1950	2.66	3750	4.33	5550	5.96
200	0.68	2000	2.74	3800	4.36	5600	6.02
250	0.77	2050	2.76	3850	4.38	5650	6.02
300	0.86	2100	2.80	3900	4.46	5700	6.09
350	0.94	2150	2.84	3950	4.52	5750	6.14
400	1.01	2200	2.89	4000	4.48	5800	6.15
450	1.08	2250	2.94	4050	4.52	5850	6.22
500	1.16	2300	2.98	4100	4.64	5900	6.29
550	1.21	2350	3.03	4150	4.62	5950	6.32
600	1.28	2400	3.07	4200	4.69	6000	6.39
650	1.35	2450	3.11	4250	4.75	6050	6.40
700	1.41	2500	3.15	4300	4.79	6100	6.48
750	1.48	2550	3.21	4350	4.83	6150	6.57
800	1.54	2600	3.25	4400	4.90	6200	6.62
850	1.58	2650	3.29	4450	4.95	6250	6.68
900	1.65	2700	3.33	4500	4.98	6300	6.74
950	1.67	2750	3.39	4550	5.04	6350	6.79
1000	1.74	2800	3.45	4600	5.08	6400	6.82
1050	1.79	2850	3.48	4650	5.12	6450	6.83
1100	1.84	2900	3.51	4700	5.15	6500	6.91
1150	1.91	2950	3.58	4750	5.22		
1200	1.94	3000	3.62	4800	5.26		
1250	1.99	3050	3.65	4850	5.29		
1300	2.06	3100	3.69	4900	5.33		
1350	2.11	3150	3.75	4950	5.36		
1400	2.16	3200	3.77	5000	5.38		
1450	2.21	3250	3.80	5050	5.46		
1500	2.25	3300	3.85	5100	5.49		
1550	2.30	3350	3.90	5150	5.56		
1600	2.35	3400	3.94	5200	5.58		
1650	2.38	3450	4.00	5250	5.64		
1700	2.42	3500	4.03	5300	5.69		



Cable loss
Microwave Cable Assembly, Huber-Suhner, 40 GHz, 1.5 m, SMA-SMA, S/N 1226/2A
HL 3903

Frequency, MHz	Cable loss, dB	Frequency, MHz	Cable loss, dB	Frequency, MHz	Cable loss, dB
10	-0.02	9500	1.84	21000	2.98
100	0.15	10000	1.86	22000	3.07
500	0.38	10500	1.93	23000	3.13
1000	0.56	11000	1.99	24000	3.21
1500	0.69	11500	2.04	25000	3.26
2000	0.82	12000	2.10	26000	3.48
2500	0.90	12500	2.15	27000	3.44
3000	0.98	13000	2.21	28000	3.53
3500	1.06	13500	2.25	29000	3.59
4000	1.11	14000	2.29	30000	3.66
4500	1.17	14500	2.34	31000	3.70
5000	1.24	15000	2.36	32000	3.79
5500	1.32	15500	2.40	33000	3.88
6000	1.40	16000	2.45	34000	3.94
6500	1.50	16500	2.48	35000	3.91
7000	1.56	17000	2.56	36000	4.05
7500	1.62	17500	2.58	37000	4.22
8000	1.68	18000	2.60	38000	4.25
8500	1.74	19000	2.84	39000	4.27
9000	1.78	20000	2.88	40000	4.33



Cable loss
Test cable, Mini-Circuits, S/N 0748A, 18 GHz, 3.05 m, N/M - N/M
APC-10FT-NMNM+, HL 4277

Frequency, MHz	Cable loss, dB	Frequency, MHz	Cable loss, dB	Frequency, MHz	Cable loss, dB	Frequency, MHz	Cable loss, dB
10	0.12	4400	3.19	9000	4.82	13600	5.97
30	0.21	4500	3.24	9100	4.87	13700	6.01
50	0.28	4600	3.29	9200	4.90	13800	6.04
100	0.40	4700	3.34	9300	4.96	13900	6.09
200	0.59	4800	3.37	9400	4.99	14000	6.12
300	0.73	4900	3.41	9500	5.03	14100	6.16
400	0.86	5000	3.45	9600	5.07	14200	6.20
500	0.97	5100	3.48	9700	5.11	14300	6.22
600	1.07	5200	3.52	9800	5.13	14400	6.26
700	1.15	5300	3.56	9900	5.15	14500	6.29
800	1.23	5400	3.58	10000	5.17	14600	6.33
900	1.31	5500	3.62	10100	5.19	14700	6.33
1000	1.39	5600	3.65	10200	5.19	14800	6.35
1100	1.46	5700	3.69	10300	5.21	14900	6.38
1200	1.54	5800	3.72	10400	5.22	15000	6.38
1300	1.60	5900	3.76	10500	5.22	15100	6.40
1400	1.67	6000	3.80	10600	5.22	15200	6.42
1500	1.74	6100	3.84	10700	5.25	15300	6.46
1600	1.79	6200	3.89	10800	5.25	15400	6.51
1700	1.86	6300	3.92	10900	5.26	15500	6.55
1800	1.92	6400	3.96	11000	5.29	15600	6.56
1900	1.98	6500	4.00	11100	5.30	15700	6.59
2000	2.04	6600	4.04	11200	5.31	15800	6.60
2100	2.09	6700	4.07	11300	5.35	15900	6.64
2200	2.14	6800	4.11	11400	5.36	16000	6.65
2300	2.20	6900	4.14	11500	5.39	16100	6.65
2400	2.25	7000	4.17	11600	5.41	16200	6.67
2500	2.31	7100	4.21	11700	5.45	16300	6.69
2600	2.36	7200	4.23	11800	5.48	16400	6.71
2700	2.42	7300	4.27	11900	5.51	16500	6.72
2800	2.46	7400	4.30	12000	5.53	16600	6.73
2900	2.51	7500	4.34	12100	5.56	16700	6.75
3000	2.56	7600	4.37	12200	5.59	16800	6.80
3100	2.60	7700	4.40	12300	5.61	16900	6.82
3200	2.65	7800	4.44	12400	5.62	17000	6.85
3300	2.70	7900	4.47	12500	5.65	17100	6.90
3400	2.75	8000	4.49	12600	5.68	17200	6.96
3500	2.80	8100	4.53	12700	5.71	17300	7.02
3600	2.85	8200	4.57	12800	5.73	17400	7.07
3700	2.90	8300	4.60	12900	5.76	17500	7.06
3800	2.95	8400	4.63	13000	5.80	17600	7.06
3900	2.98	8500	4.67	13100	5.83	17700	7.08
4000	3.02	8600	4.69	13200	5.86	17800	7.09
4100	3.07	8700	4.73	13300	5.88	17900	7.07
4200	3.10	8800	4.76	13400	5.91	18000	7.08
4300	3.14	8900	4.79	13500	5.94		



Cable loss
RF Cable, Huber-Suhner, 40 GHz, 5.5 m, K type,
SF102EA/11SK/11SK/5500MM, S/N 502493/2EA
HL 5111

Frequency, MHz	Cable loss, dB	Frequency, MHz	Cable loss, dB
100	0.68	20500	10.17
200	0.97	21000	10.30
300	1.18	21500	10.43
500	1.52	22000	10.58
1000	2.14	22500	10.73
1500	2.62	23000	10.85
2000	3.03	23500	10.98
2500	3.39	24000	11.11
3000	3.72	24500	11.20
3500	4.03	25000	11.32
4000	4.32	25500	11.47
4500	4.59	26000	11.59
5000	4.84	26500	11.72
5500	5.09	27000	11.83
6000	5.32	27500	11.94
6500	5.55	28000	12.04
7000	5.77	28500	12.16
7500	5.99	29000	12.28
8000	6.19	29500	12.40
8500	6.40	30000	12.50
9000	6.60	30500	12.59
9500	6.79	31000	12.68
10000	6.98	31500	12.80
10500	7.16	32000	12.94
11000	7.34	32500	13.09
11500	7.51	33000	13.23
12000	7.68	33500	13.32
12500	7.84	34000	13.44
13000	8.00	34500	13.54
13500	8.15	35000	13.68
14000	8.31	35500	13.81
14500	8.46	36000	13.90
15000	8.62	36500	13.99
15500	8.76	37000	14.12
16000	8.91	37500	14.22
16500	9.06	38000	14.33
17000	9.21	38500	14.47
17500	9.35	39000	14.54
18000	9.49	39500	14.62
18500	9.62	40000	14.75
19000	9.76		
19500	9.90		
20000	10.05		



HERMON LABORATORIES

Cable loss
RF Cable, Huber-Suhner, 18 GHz, 6 m, 6,
SF118/11N(x2), S/N 500023/118
HL 5111

3405

Specific Test Report



Frequency Range [GHz]	IL min S21 [dB]	IL min S12 [dB]	RL max S11 [dB]	RL max S22 [dB]
0.040 - 1.836	-1.431	-1.431	-37.037	-37.704
1.836 - 3.632	-2.062	-2.066	-33.573	-32.848
3.632 - 5.428	-2.576	-2.576	-28.548	-29.602
5.428 - 7.224	-3.013	-3.014	-30.738	-32.523
7.224 - 9.020	-3.415	-3.416	-33.728	-32.257
9.020 - 10.816	-3.772	-3.772	-29.302	-30.735
10.816 - 12.612	-4.138	-4.138	-28.768	-26.255
12.612 - 14.408	-4.456	-4.462	-27.109	-26.151
14.408 - 16.204	-4.786	-4.786	-26.056	-27.116
16.204 - 18.000	-5.113	-5.111	-27.762	-28.508

Type: SF118/11N/11N/6000MM
Sales no.: 10497130
Serial no.: 500023 /118
PA no.: 1956306
Ring no.:
Cable length: 6 m
Test length:
Connector 1: SF_11_N-656
Connector 2: SF_11_N-656
Cable: SUCOFLEX_118
Meas. System: N5230C,MY49001834,A.09.42.22

Time: 7:04:21 AM
Date: 6/6/2018
Inspected by: AZ /111

Start Freq.: 0.04000 GHz
Stop Freq.: 18.00000 GHz
Meas Points: 801
Source Power: -5 dBm

14 APPENDIX F Abbreviations and acronyms

A	ampere
AC	alternating current
AM	amplitude modulation
AVRG	average (detector)
cm	centimeter
dB	decibel
dBm	decibel referred to one milliwatt
dB(μ V)	decibel referred to one microvolt
dB(μ V/m)	decibel referred to one microvolt per meter
dB(μ A)	decibel referred to one microampere
DC	direct current
EIRP	equivalent isotropically radiated power
ERP	effective radiated power
EUT	equipment under test
F	frequency
GHz	gigahertz
GND	ground
H	height
HL	Hermon laboratories
Hz	hertz
k	kilo
kHz	kilohertz
LO	local oscillator
m	meter
MHz	megahertz
min	minute
mm	millimeter
ms	millisecond
μ s	microsecond
NA	not applicable
NB	narrow band
OATS	open area test site
Ω	Ohm
PM	pulse modulation
PS	power supply
ppm	part per million (10^{-6})
QP	quasi-peak
RE	radiated emission
RF	radio frequency
rms	root mean square
Rx	receive
s	second
T	temperature
Tx	transmit
V	volt
WB	wideband

END OF DOCUMENT