



# TEST REPORT

**FCC ID: 2AHI3MAGIC**

For

Inomatic (Suzhou) Technology Co., Ltd.

8.2MHz EAS System

Model No. : Magic250/350 UMB200S Mono System, Helio250 UMB200S Mono System

Trade name : N/A

Prepared for : Inomatic (Suzhou) Technology Co., Ltd.

Address : DongFu Road No.45, 3rd F, Building 2, Phase 2, Loufeng Industrial Investment Zone, Suzhou Industrial Park, China 215123

Prepared by : Shenzhen Alpha Product Testing Co., Ltd.

Address : Building B, East Area of Nanchang Second, Industrial Zone, Gushu 2nd Road, Bao'an, Shenzhen, China

Report No. : T1871096 01

Date of Receipt : June 17, 2017

Date of Test : June 17-27, 2017

Date of Report : June 27, 2017

Version Number : REV0

## Contents

<b>1. General Information</b>	<b>4</b>
1.1. Description of Device (EUT)	4
1.2. Accessories of device (EUT)	5
1.3. Test Lab information	5
<b>2. Summary of test</b>	<b>6</b>
2.1. Summary of test result	6
2.2. Assistant equipment used for test	6
2.3. Block Diagram	6
2.4. Test mode	6
2.5. Test Conditions	6
2.6. Measurement Uncertainty (95% confidence levels, k=2)	7
2.7. Test Equipment	8
<b>3. Radiated emissions</b>	<b>9</b>
3.1. Limit(FCC 15.209)	9
3.2. Block Diagram of Test setup	9
3.3. Test Procedure	10
3.4. Test Result	11
<b>4. 6dB bandwidth</b>	<b>18</b>
4.1. Limit	18
4.2. Test Procedure	18
4.3. Test Setup	18
4.4. Test Result	18
<b>5. Power Line Conducted Emissions</b>	<b>20</b>
5.1. Block Diagram of Test Setup	20
5.2. Limit	20
5.3. Test Procedure	20
5.4. Test Result	21
<b>6. Antenna Requirements</b>	<b>25</b>
6.1. Limit	25
6.2. Result	25
<b>7. Test setup photo</b>	<b>26</b>
<b>8. Photos of EUT</b>	<b>28</b>

# DECLARATION

Applicant : Inomatic (Suzhou) Technology Co., Ltd.  
 Manufacturer : Inomatic (Suzhou) Technology Co., Ltd.  
 Product : 8.2MHz EAS System  
 (A) Model No. : Magic250/350 UMB200S Mono System,  
 Helio250 UMB200S Mono System  
 (B) Trade Name : N/A  
 (C) Power supply : DC 24V from adapter with AC 120V/60Hz

Measurement Standard Used:

**FCC Rules and Regulations Part 15 Subpart C Section 15.223: 2016,**  
**ANSI C63.4-2014, ANSI C63.10-2013**

The device described above is tested by Shenzhen Alpha Product Testing Co., Ltd. to determine the maximum emission levels emanating from the device. The maximum emission levels are compared to the FCC Part 15 Subpart B Class B limits both conducted and radiated emissions. The test results are contained in this test report and Shenzhen Alpha Product Testing Co., Ltd. is assumed of full responsibility for the accuracy and completeness of these tests.

After the test, our opinion is that EUT compliance with the requirement of the above standards.

This report applies to above tested sample only. This report shall not be reproduced in parts without written approval of Shenzhen Alpha Product Testing Co., Ltd.

Tested by (name + signature).....: Eric Huang  
 Project Engineer

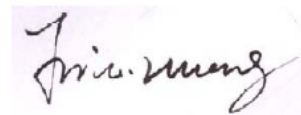

Approved by (name + signature).....: Simple Guan  
 Project Manager



Date of issue.....: June 27, 2017

# 1. General Information

## 1.1. Description of Device (EUT)

EUT	:	8.2MHz EAS System
Model No.	:	Magic250/350 UMB200S Mono System, Helio250 UMB200S Mono System
DIFF	:	Only model name different.
Trade mark	:	N/A
Power supply	:	DC 24V from adapter with AC 120V/60Hz
Adapter	:	Model: WDY-24004000 Input: AC100-240V, 50/60Hz, 2.0A Output: DC 24V/4A
Operation frequency	:	8.2MHz
Antenna Type and Gain	:	Integrated antenna, PK Gain: 0dBi
Applicant	:	Inomatic (Suzhou) Technology Co., Ltd.
Address	:	DongFu Road No.45, 3rd F, Building 2, Phase 2, Loufeng Industrial Investment Zone, Suzhou Industrial Park, China 215123
Manufacturer	:	Inomatic (Suzhou) Technology Co., Ltd.
Address	:	DongFu Road No.45, 3rd F, Building 2, Phase 2, Loufeng Industrial Investment Zone, Suzhou Industrial Park, China 215123

## 1.2. Accessories of device (EUT)

Accessories 1 : Adapter

M/N : WDY-2400-4000

## 1.3. Test Lab information

Shenzhen Alpha Product Testing Co., Ltd.

Building B, East Area of Nanchang Second, Industrial Zone, Gushu 2nd  
Road, Bao'an, Shenzhen, China

March 25, 2015 File on Federal Communication Commission

Registration Number: 203110

July 18, 2014 Certificated by IC

Registration Number: 12135A

## 2. Summary of test

### 2.1. Summary of test result

Description of Test Item	Standard	Results
Radiated Emission (9KHz-1.25MHz)	FCC Part 15: 209 ANSI C63.4 :2014	PASS
6dB Bandwidth	FCC Part 15.223	PASS
Power Line Conducted Emissions (150KHz-30MHz)	FCC Part 15: 15.207 ANSI C63.4 :2014	PASS
Antenna Requirement	FCC Part 15: 15.203	PASS

### 2.2. Assistant equipment used for test

N/A

### 2.3. Block Diagram

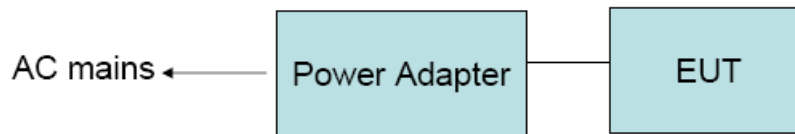

### 2.4. Test mode

Tested mode, channel, and data rate information		
Mode	Channel	Frequency (MHz)
1	CH1	8.2

Note: According exploratory test, EUT will have maximum output power in those data rate. so those data rate were used for all test.

### 2.5. Test Conditions

Temperature range	21-25°C
Humidity range	40-75%
Pressure range	86-106kPa

## 2.6. Measurement Uncertainty (95% confidence levels, k=2)

Item	MU	Remark
Uncertainty for Power point Conducted Emissions Test	2.71dB	
Uncertainty for Radiation Emission test in 3m chamber (below 30MHz)	2.13 dB	Polarize: V
	2.57dB	Polarize: H
Uncertainty for Radiation Emission test in 3m chamber (30MHz to 1GHz)	3.90 dB	Polarize: V
	3.92dB	Polarize: H
Uncertainty for Radiation Emission test in 3m chamber (1GHz to 25GHz)	4.26 dB	Polarize: H
	4.28 dB	Polarize: V
Uncertainty for radio frequency	$1 \times 10^{-9}$	
Uncertainty for DC and low frequency voltages	0.06%	

## 2.7. Test Equipment

Equipment	Manufacture	Model No.	Serial No.	Last cal.	Cal Interval
3m Semi-Anechoic	ETS-LINDGREN	N/A	SEL0017	2016.09.29	1Year
Spectrum analyzer	Agilent	E4407B	MY46185649	2016.09.29	1Year
Receiver	R&S	ESCI	1166.5950K03-1011	2016.09.29	1Year
Receiver	R&S	ESCI	101202	2016.09.29	1Year
Bilog Antenna	Schwarzbeck	VULB 9168	VULB9168-438	2016.09.30	2Year
Horn Antenna	EMCO	3115	640201028-06	2016.09.30	2Year
Active Loop Antenna	Beijing Daze	ZN30900A	SEL0097	2016.09.30	2Year
Cable	Resenberger	N/A	No.1	2016.09.29	1Year
Cable	SCHWARZBECK	N/A	No.2	2016.09.29	1Year
Cable	SCHWARZBECK	N/A	No.3	2016.09.29	1Year
Pre-amplifier	Schwarzbeck	BBV9743	9743-019	2016.09.29	1Year
Pre-amplifier	R&S	AFS33-18002650-30-8P-44	SEL0080	2016.09.29	1Year
Base station	Agilent	E5515C	GB44300243	2016.09.29	1 Year
Temperature controller	Terchy	MHQ	120	2016.09.29	1Year
Power divider	Anritsu	K240C	020346	2016.09.29	1 Year
Signal Generator	HP	83732B	VS3449051	2016.09.29	1 Year
Power Meter	Anritsu	ML2487A	6K00001491	2016.09.29	1Year
Power sensor	Anritsu	ML2491A	32516	2016.09.29	1Year
L.I.S.N.#1	Schwarzbeck	NSLK8126	8126466	2016.09.29	1Year
L.I.S.N.#2	ROHDE&SCHWARZ	ENV216	101043	2016.09.29	1 Year



### 3. Radiated emissions

#### 3.1. Limit(FCC 15.209)

Frequency (MHz)	Field Strength		Field Strength Limit at 3m Measurement Dist	
	uV/m	Distance (m)	uV/m	dBuV/m
0.009 ~ 0.490	2400/F(kHz)	300	10000 * 2400/F(kHz)	$20\log^{(2400/F(kHz))} + 80$
0.490 ~ 1.705	24000/F(kHz)	30	100 * 24000/F(kHz)	$20\log^{(24000/F(kHz))} + 40$
1.705 ~ 30	30	30	100 * 30	$20\log^{(30)} + 40$
30 ~ 88	100	3	100	$20\log^{(100)}$
88 ~ 216	150	3	150	$20\log^{(150)}$
216 ~ 960	200	3	200	$20\log^{(200)}$
Above 960	500	3	500	$20\log^{(500)}$

Note:

- a) The tighter limit applies at the band edges.  
For example: F.S limit at 88MHz is 100uV/m
- b) If measurement is made at 3m distance, then F.S Limit at 3m distance is adjusted by using the formula of  $L_{d1} = L_{d2} * (d2/d1)^2$ .  
For example:  
F.S Limit at 30m(d2) distance is 30uV/m( $L_{d2}$ ), then F.S Limit at 3m(d1) distance is  
 $L_{d1} = 30\text{uV/m} * (30/3)^2 = 100 * 30\text{uV/m} = 69.54 \text{ dBuV/m}$

#### 3.2. Block Diagram of Test setup

In 3m Anechoic Chamber Test Setup Diagram for below 30MHz

#### 4.2. Block diagram of test setup

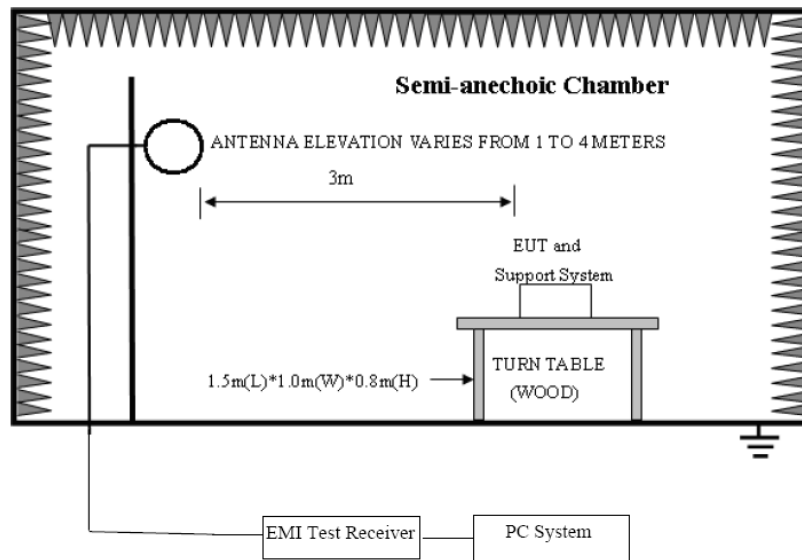

In 3m Anechoic Chamber Test Setup Diagram for frequency 30MHz-1GHz

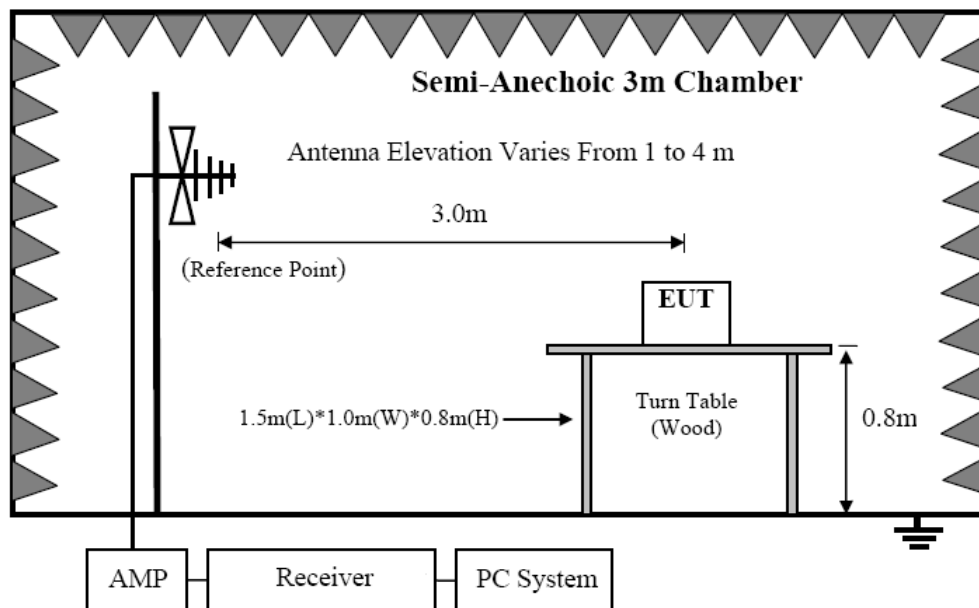

### 3.3. Test Procedure

#### Procedure of Preliminary Test

The EUT and Support equipment, if needed, were put placed on a non-metallic table, 80cm above the ground plane.

Configuration EUT to simulate typical usage as described in clause 2.4 and test equipment as described in clause 4.2 of this report.

All I/O cables were positioned to simulate typical actual usage as per ANSI C63.4:2014.

Mains cables, telephone lines or other connections to auxiliary equipment located outside the test are shall drape to the floor, be fitted with ferrite clamps or ferrite tubes placed on the floor at the point where the cable reaches the floor and then routed to the place where they leave the turntable.

No extension cords shall be used to mains receptacle.

The antenna was placed at 3 meter away from the EUT as stated in ANSI C63.10:2009. The antenna connected to the Spectrum Analyzer via a cable and at times a pre-amplifier would be used.

The Receiver quickly scanned from 9KHz to 30MHz and 30MHz to 1GHz The EUT test program was started. Emissions were scanned and measured rotating the EUT to 360 degrees and positioning the antenna 1 to 4 meters above the ground plane, in both the vertical and the horizontal polarization, to maximize the emission reading level.

The test mode(s) described in clause 2.4 were scanned during the preliminary test:

After the preliminary scan, we found the test mode producing the highest emission level. The EUT and cable configuration, antenna position, polarization and turntable position of the above highest emission level were recorded for the final test.

#### **Procedure of Final Test**

EUT and support equipment were set up on the turntable as per the configuration with highest emission level in the preliminary test.

The Receiver scanned from 9KHz to 30MHz and 30MHz to 1GHz. Emissions were scanned and measured rotating the EUT to 360 degrees, varying cable placement and positioning the antenna 1 to 4 meters above the ground plane, in both the vertical and the horizontal polarization, to maximize the emission reading level.

Recorded at least the six highest emissions. Emission frequency, amplitude, antenna position, polarization and turntable position were recorded into a computer in which correction factors were used to calculate the emission level and compare reading to the applicable limit and only Q.P. reading is presented.

The test data of the worst-case condition(s) was recorded.

The bandwidth of test receiver is set at 200Hz for 9 KHz to 150 KHz measure, 10 KHz for 150 KHz to 30MHz measure and 120 KHz for 30 MHz to 1GHz measure.

### **3.4. Test Result**

**PASS. (See below detailed test result)**

ANT1:

Freq. (MHz)	Ant. Pol H/V	Peak Reading (dBuV)	AV Reading (dBuV)	Ant. / CL CF (dB)	Actual Fs		Peak Limit (dBuV/m)	AV Limit (dBuV/m)	Margin (dB)	Remarks
					Peak (dBuV/m)	AV (dBuV/m)				
0.110	--	22.67	---	24.80	47.47	---	126.77	---	79.30	Peak
1.7050	--	22.45	---	25.06	47.51	---	69.50	---	21.99	Peak
8.200	--	28.57	---	25.03	53.60	---	83.50	63.50	29.90	Peak
8.291	--	20.84	---	25.02	45.86	---	69.50	---	23.64	Peak
8.294	--	21.47	---	25.01	46.48	---	69.50	---	23.02	Peak
8.362	--	22.04	---	25.01	47.05	---	69.50	---	22.45	Peak
10.000	--	22.68	---	25.10	47.78	---	69.50	---	21.72	Peak
16.400	--	22.04	---	25.06	47.10	---	69.50	---	22.40	Peak
24.600	--	27.61	---	25.14	52.75	---	69.50	---	16.75	Peak
N/A										

Note:

8.2MHz Limit: (the bandwidth of the device in kHz)divided by (the center frequency of the device in MHz)=19.21kHz/8.2MHz=2.34 < 15,

So the limits 30m is (20log15 microvolts/meter)+40=63.5dBuV/m

Site: LAB	Polarization: <b>Vertical</b>	Temperature: 26.1
Limit: FCC Class B Radiation	Power:	Humidity: 48 %
EUT: 8.2MHz EAS System	Distance: 3m	
M/N:		
Mode:		
Note:		

**Radiated Emission Measurement**

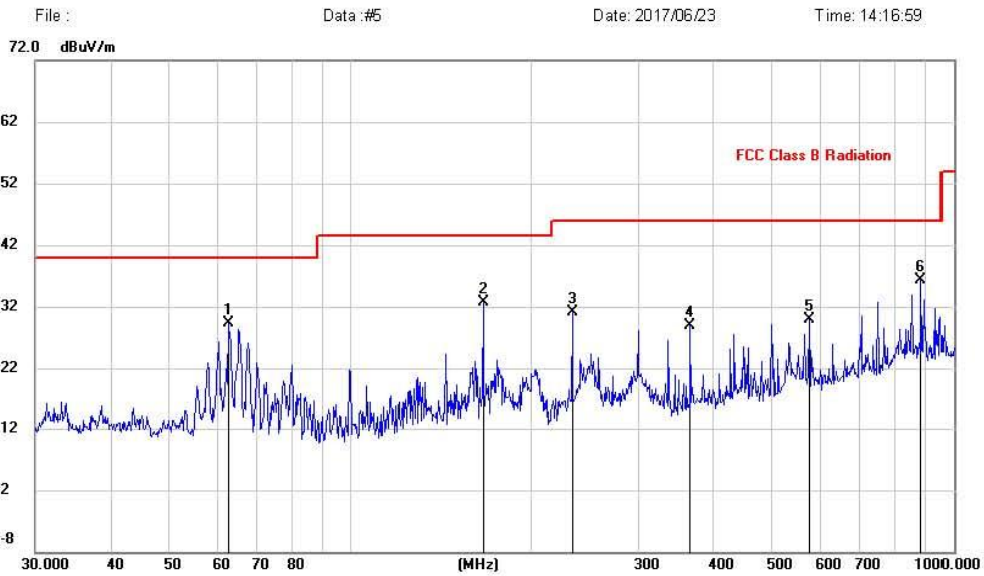

No.	Mk.	Freq.	Reading Level	Correct Factor	Measurement	Limit	Margin	Antenna Height	Table Degree	
		MHz	dBuV	dB	dBuV/m	dBuV/m	dB	cm	degree	Comment
1		62.8707	17.09	12.24	29.33	40.00	-10.67	peak		
2		166.0680	18.63	14.09	32.72	43.50	-10.78	peak		
3		232.5318	19.29	11.84	31.13	46.00	-14.87	peak		
4		365.5391	14.00	14.89	28.89	46.00	-17.11	peak		
5		576.6443	10.84	18.99	29.83	46.00	-16.17	peak		
6	*	887.6098	13.48	22.83	36.31	46.00	-9.69	peak		

Site: LAB	Polarization: <b>Horizontal</b>	Temperature: 26.1
Limit: FCC Class B Radiation	Power:	Humidity: 48 %
EUT: 8.2MHz EAS System	Distance: 3m	
M/N:		
Mode:		
Note:		

**Radiated Emission Measurement**

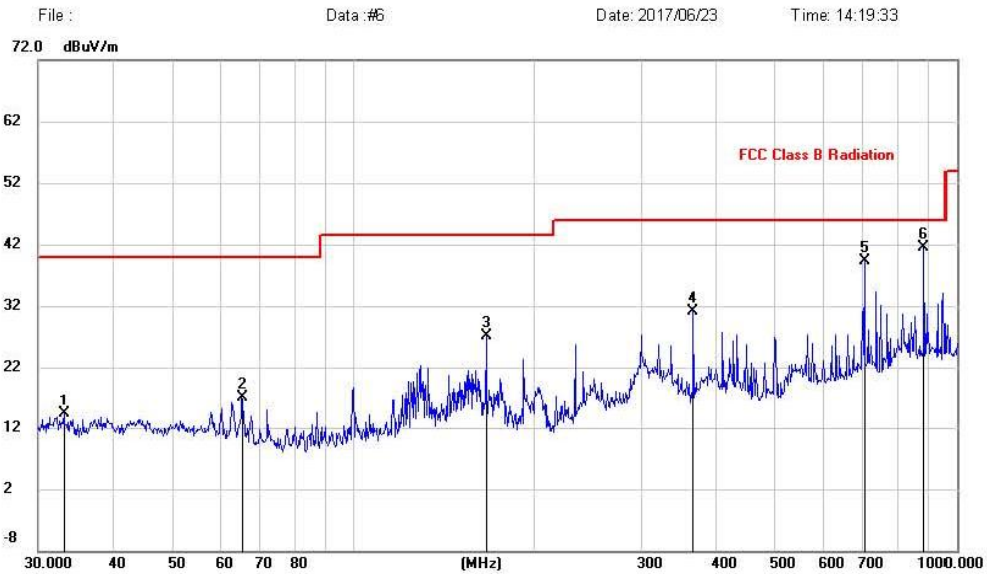

No.	Mk.	Freq.	Reading Level	Correct Factor	Measurement	Limit	Margin	Antenna Height	Table Degree
		MHz	dBuV	dB	dBuV/m	dBuV/m	dB	cm	degree
1		33.0950	0.84	13.44	14.28	40.00	-25.72	peak 100	271
2		65.3432	5.26	11.84	17.10	40.00	-22.90	peak 200	265
3		166.0680	13.00	14.09	27.09	43.50	-16.41	peak 200	80
4		365.5391	16.31	14.89	31.20	46.00	-14.80	peak 100	24
5		704.2261	18.77	20.47	39.24	46.00	-6.76	peak 100	334
6	*	887.6099	18.62	22.83	41.45	46.00	-4.55	peak 200	360

ANT2:

Freq. (MHz)	Ant. Pol H/V	Peak Reading (dBuV)	AV Reading (dBuV)	Ant. / CL CF (dB)	Actual Fs		Peak Limit (dBuV/m)	AV Limit (dBuV/m)	Margin (dB)	Remark
					Peak (dBuV/m)	AV (dBuV/m)				
0.110	--	22.35	---	24.80	47.15	---	126.77	---	79.62	Peak
1.7050	--	22.49	---	25.06	47.55	---	69.50	---	21.95	Peak
8.200	--	29.05	---	25.03	54.08	---	83.50	63.50	29.42	Peak
8.291	--	20.69	---	25.02	45.71	---	69.50	---	23.79	Peak
8.294	--	21.39	---	25.01	46.40	---	69.50	---	23.10	Peak
8.362	--	21.97	---	25.01	46.98	---	69.50	---	22.52	Peak
10.000	--	22.54	---	25.10	47.64	---	69.50	---	21.86	Peak
16.400	--	22.15	---	25.06	47.21	---	69.50	---	22.29	Peak
24.600	--	26.02	---	25.14	51.16	---	69.50	---	18.34	Peak
N/A										

Note:

8.2MHz Limit: (the bandwidth of the device in kHz)divided by (the center frequency of the device in MHz)=18.34kHz/8.2MHz=2.24 < 15,

So the limits is (20log15 microvolts/meter)+40=63.5dBuV/m

Site: LAB	Polarization: <b>Horizontal</b>	Temperature: 26.1
Limit: FCC Class B Radiation	Power:	Humidity: 48 %
EUT: 8.2MHz EAS System	Distance: 3m	
M/N:		
Mode:		
Note:		

**Radiated Emission Measurement**

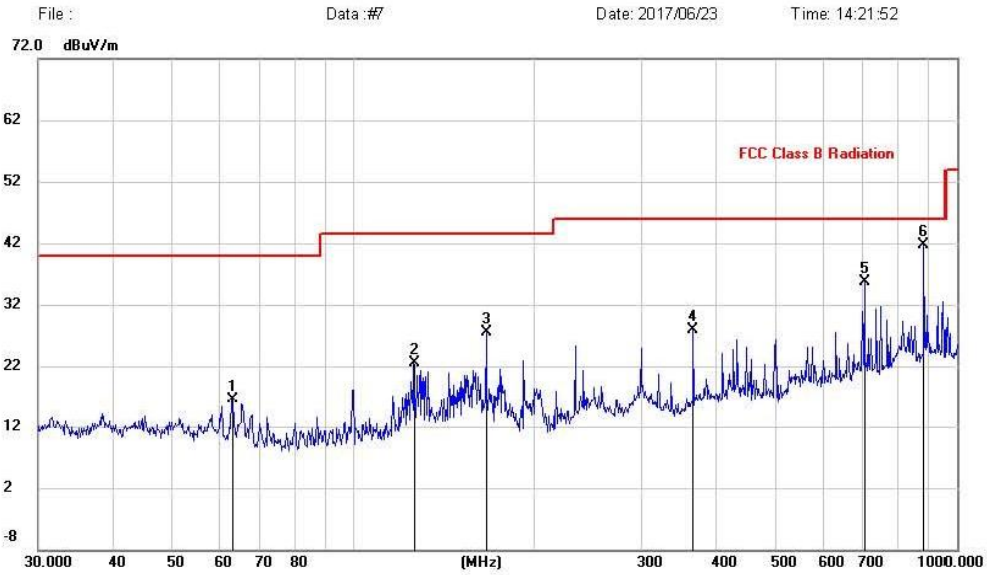

No.	Mk.	Freq.	Reading Level	Correct Factor	Measurement	Limit	Margin	Antenna Height	Table Degree	
		MHz	dBuV	dB	dBuV/m	dBuV/m	dB	cm	degree	Comment
1		62.8708	4.22	12.24	16.46	40.00	-23.54			peak
2		126.3286	9.55	13.00	22.55	43.50	-20.95			peak
3		166.0680	13.48	14.09	27.57	43.50	-15.93			peak
4		365.5391	13.04	14.89	27.93	46.00	-18.07			peak
5		704.2261	15.23	20.47	35.70	46.00	-10.30			peak
6	*	887.6099	18.93	22.83	41.76	46.00	-4.24			peak



Site: LAB	Polarization: <b>Vertical</b>	Temperature: 26.1
Limit: FCC Class B Radiation	Power:	Humidity: 48 %
EUT: 8.2MHz EAS System	Distance: 3m	
M/N:		
Mode:		
Note:		

**Radiated Emission Measurement**

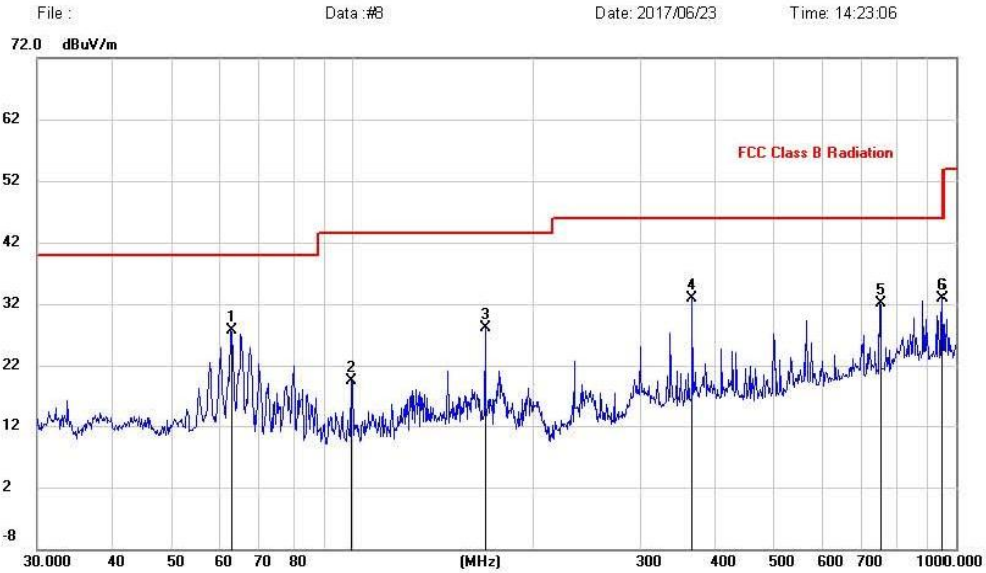

No.	Mk.	Freq.	Reading Level	Correct Factor	Measurement	Limit	Margin	Antenna Height	Table Degree	
		MHz	dBuV	dB	dBuV/m	dBuV/m	dB	cm	degree	Comment
1	*	62.8708	15.56	12.24	27.80	40.00	-12.20			peak
2		99.5281	8.85	10.57	19.42	43.50	-24.08			peak
3		166.0680	13.96	14.09	28.05	43.50	-15.45			peak
4		365.5391	18.01	14.89	32.90	46.00	-13.10			peak
5		752.7432	10.60	21.45	32.05	46.00	-13.95			peak
6		952.0937	9.23	23.58	32.81	46.00	-13.19			peak

## 4. 6dB bandwidth

### 4.1. Limit

Intentional radiators operating under the alternative provisions to the general emission limits, as contained in §§ 15.223, must be designed to ensure that the 6dB bandwidth of the emission, or whatever bandwidth may otherwise be specified in the specific rule section under which the equipment operates, is contained within the frequency band designated in the rule section under which the equipment is operated.

### 4.2. Test Procedure

The transmitter output was coupled to a spectrum analyzer via a antenna. The bandwidth of the fundamental frequency was measured by spectrum analyzer with 3KHz RBW and 10kHz VBW. The 6dB bandwidth is defined as the total spectrum the power of which is higher than peak power minus 6dB.

### 4.3. Test Setup

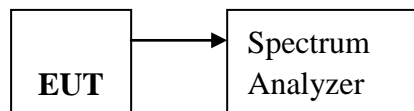

### 4.4. Test Result

EUT:8.2MHz EAS System					
M/N: Magic250/350 UMB200S Mono System					
Test date: 2017-06-27		Test site: RF site		Tested by: Simple	
Mode	Freq (MHz)		6dB Bandwidth (KHz)	Limit (kHz)	Conclusion
Tx Mode	8.2	ANT1	19.21	/	PASS
		ANT2	18.34	/	PASS

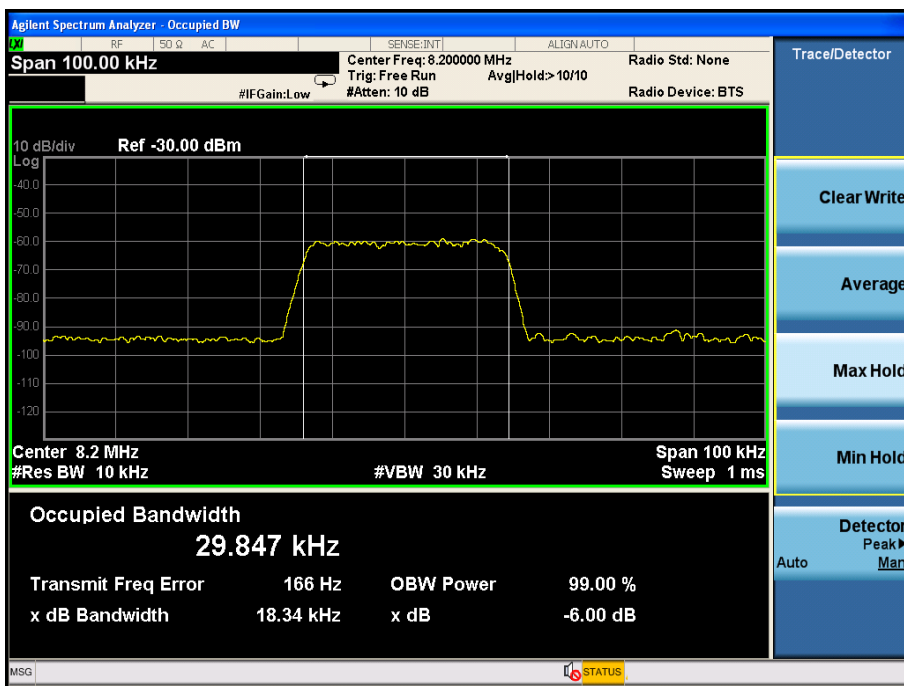
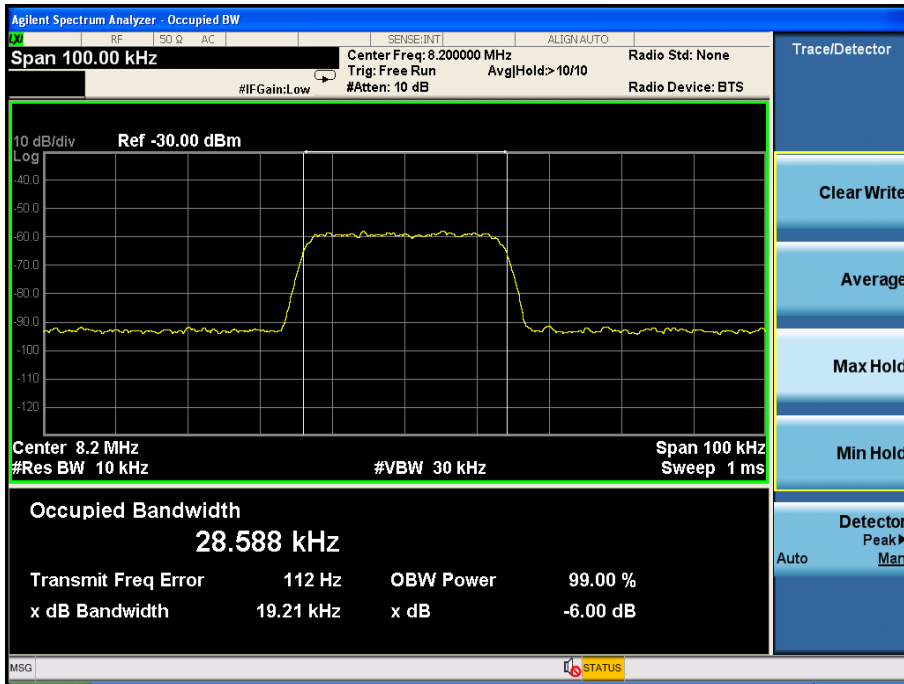

## 5. Power Line Conducted Emissions

### 5.1. Block Diagram of Test Setup

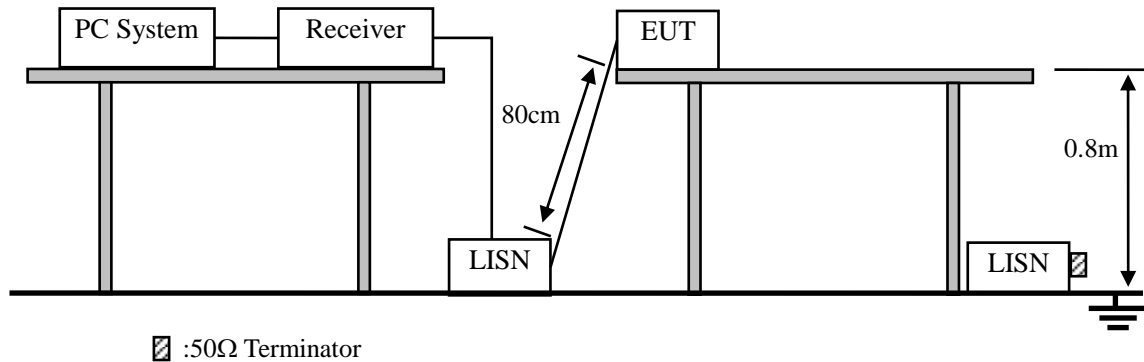

### 5.2. Limit

Frequency	Maximum RF Line Voltage	
	Quasi-Peak Level dB( $\mu$ V)	Average Level dB( $\mu$ V)
150kHz ~ 500kHz	66 ~ 56*	56 ~ 46*
500kHz ~ 5MHz	56	46
5MHz ~ 30MHz	60	50

Notes: 1. \* Decreasing linearly with logarithm of frequency.

2. The lower limit shall apply at the transition frequencies.

### 5.3. Test Procedure

- (1) The EUT was placed on a non-metallic table, 80cm above the ground plane.
- (2) Setup the EUT and simulator as shown in 10.1
- (3) The EUT Power connected to the power mains through a power adapter and a line impedance stabilization network (L.I.S.N1). The other peripheral devices power cord connected to the power mains through a line impedance stabilization network (L.I.S.N1), this provided a 50-ohm coupling impedance for the EUT (Please refer to the block diagram of the test setup and photographs). Both sides of power line were checked for maximum conducted interference. In order to find the maximum emission, the relative positions of equipments and all of the interface cables were changed according to ANSI C63.4:2014 and ANSI C63.10:2013 on conducted Emission test.
- (4) The bandwidth of test receiver is set at 10KHz.
- (5) The frequency range from 150 KHz to 30MHz is checked.

### 5.4. Test Result

**PASS. (See below detailed test data)**

**ANT1:**

Site: LAB	Phase: <b>N</b>	Temperature: 24.2
Limit: FCC Part 15 CLASS B QP	Power:	Humidity: 53 %
EUT: 8.2MHz EAS System		
M/N:		
Mode:		
Note:		

#### Conducted Emission Measurement

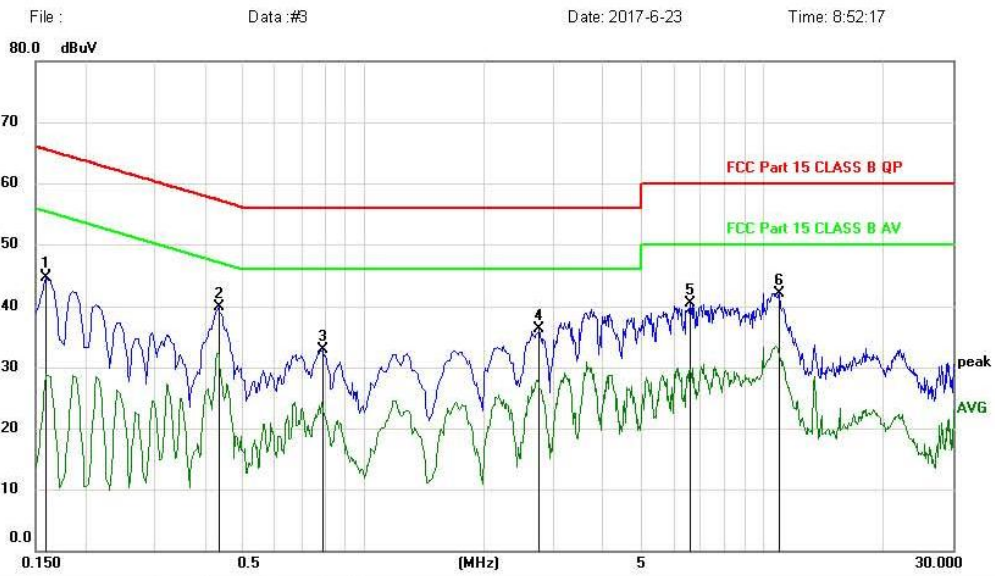

No.	Mk.	Freq. MHz	Reading Level dBuV	Correct Factor dB	Measure- ment dBuV	Limit dBuV	Margin dB	Detector	Comment
1		0.1590	35.07	9.66	44.73	65.52	-20.79	peak	
2	*	0.4334	30.12	9.71	39.83	57.19	-17.36	peak	
3		0.7842	23.14	9.73	32.87	56.00	-23.13	peak	
4		2.7604	26.31	9.97	36.28	56.00	-19.72	peak	
5		6.6204	30.30	10.24	40.54	60.00	-19.46	peak	
6		10.9801	31.84	10.36	42.20	60.00	-17.80	peak	

Site: LAB	Phase: <b>L1</b>	Temperature: 24.2
Limit: FCC Part 15 CLASS B QP	Power:	Humidity: 53 %
EUT: 8.2MHz EAS System		
M/N:		
Mode:		
Note:		

**Conducted Emission Measurement**

File : Data :#4 Date: 2017-6-23 Time: 8:51:04

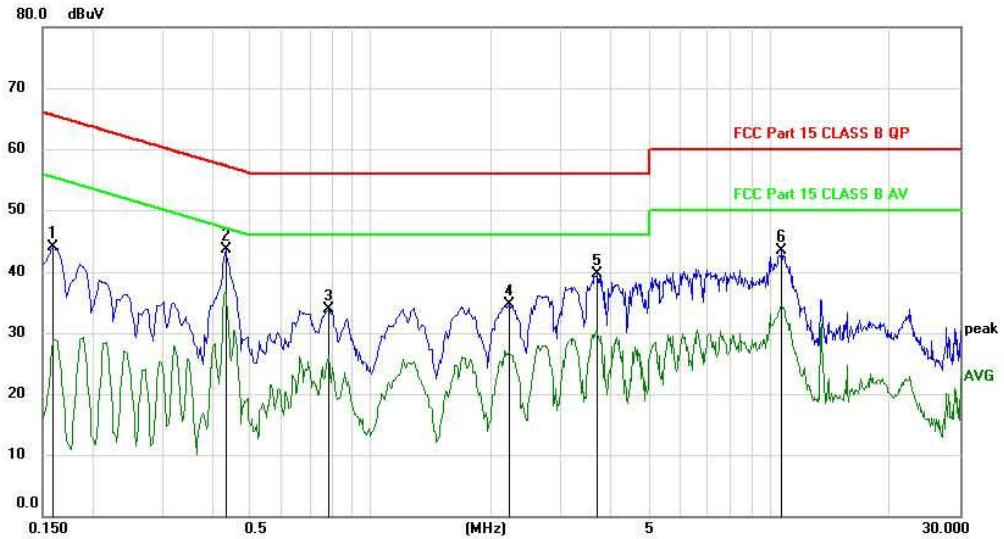

No.	Mk.	Freq. MHz	Reading Level dBuV	Correct Factor dB	Measure- ment dBuV	Limit dBuV	Margin dB	Detector	Comment
1		0.1590	34.52	9.66	44.18	65.52	-21.34	peak	
2	*	0.4334	34.03	9.71	43.74	57.19	-13.45	peak	
3		0.7799	24.16	9.74	33.90	56.00	-22.10	peak	
4		2.2204	24.82	9.91	34.73	56.00	-21.27	peak	
5		3.7004	29.69	10.06	39.75	56.00	-16.25	peak	
6		10.7004	33.07	10.35	43.42	60.00	-16.58	peak	

**ANT2:**

Site: LAB Phase: **N** Temperature: 24.2  
 Limit: FCC Part 15 CLASS B QP Power: Humidity: 53 %  
 EUT: 8.2MHz EAS System  
 M/N:  
 Mode:  
 Note:

**Conducted Emission Measurement**

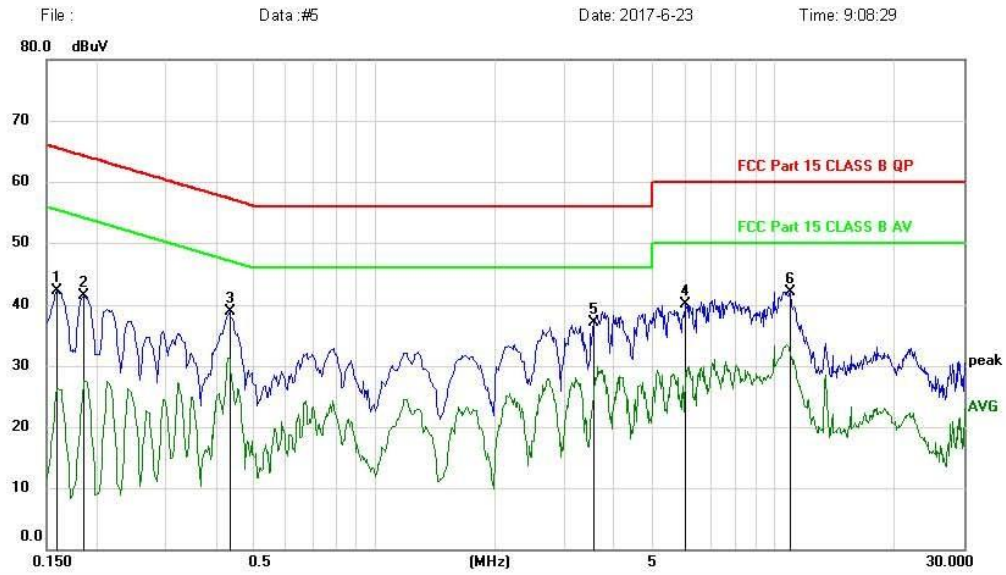

No.	Mk.	Freq. MHz	Reading Level dBuV	Correct Factor dB	Measure- ment dBuV	Limit dBuV	Margin dB	Detector	Comment
1		0.1590	32.57	9.66	42.23	65.52	-23.29	peak	
2		0.1859	31.81	9.67	41.48	64.22	-22.74	peak	
3		0.4334	29.12	9.71	38.83	57.19	-18.36	peak	
4		6.0403	29.80	10.22	40.02	60.00	-19.98	peak	
5		3.5402	27.05	10.04	37.09	56.00	-18.91	peak	
6	*	10.9801	31.84	10.36	42.20	60.00	-17.80	peak	

Site: LAB Phase: **L1** Temperature: 24.2  
 Limit: FCC Part 15 CLASS B QP Power: Humidity: 53 %  
 EUT: 8.2MHz EAS System  
 M/N:  
 Mode:  
 Note:

**Conducted Emission Measurement**

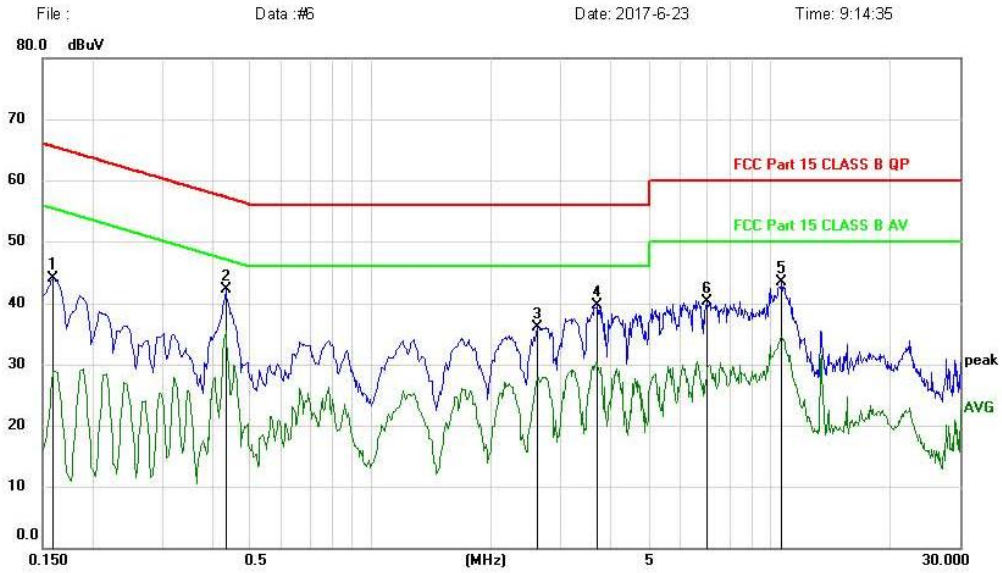

No.	Mk.	Freq. MHz	Reading Level dBuV	Correct Factor dB	Measure- ment dBuV	Limit dBuV	Margin dB	Detector	Comment
1		0.1590	34.52	9.66	44.18	65.52	-21.34	peak	
2	*	0.4334	32.53	9.71	42.24	57.19	-14.95	peak	
3		2.6204	26.18	9.96	36.14	56.00	-19.86	peak	
4		3.7004	29.69	10.06	39.75	56.00	-16.25	peak	
5		10.7004	33.07	10.35	43.42	60.00	-16.58	peak	
6		7.0204	29.99	10.23	40.22	60.00	-19.78	peak	



## **6. Antenna Requirements**

### **6.1. Limit**

For intentional device, according to FCC 47 CFR Section 15.203, an intentional radiator shall be designed to ensure that no antenna other than that furnished by the responsible party shall be used with the device. And according to FCC 47 CFR Section 15.209, if transmitting antennas of directional gain greater than 6dBi are used, the power shall be reduced by the amount in dB that the directional gain of the antenna exceeds 6dBi.

### **6.2. Result**

The antennas used for this product are integral Antenna and that no antenna other than that furnished by the responsible party shall be used with the device, the maximum peak gain of the transmit antenna is only 0dBi.

## 7. Test setup photo

### Photographs-Radiated Emission Test Setup in Chamber

Below 30M

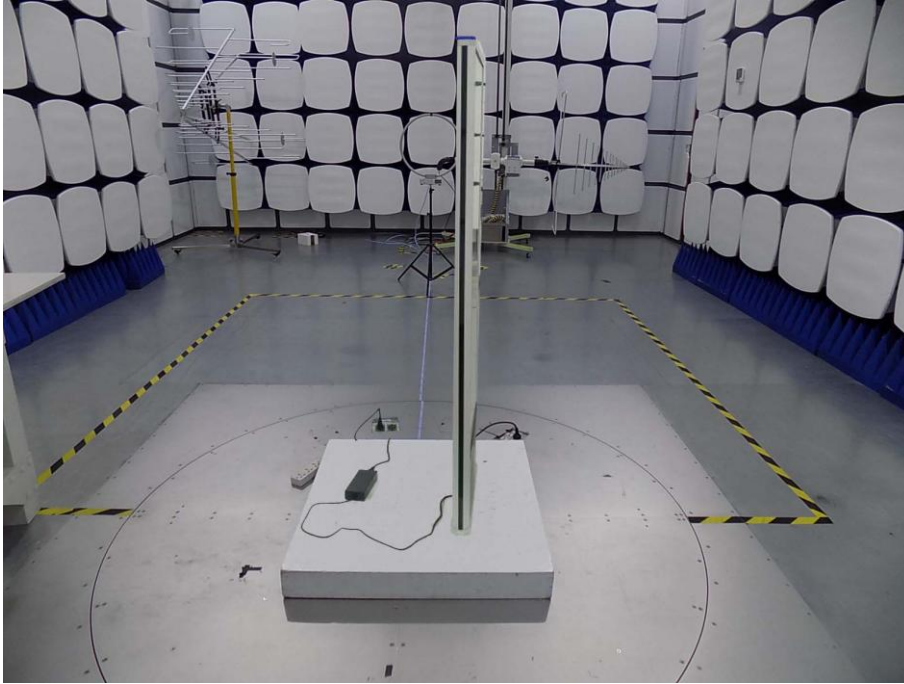

30M-1G

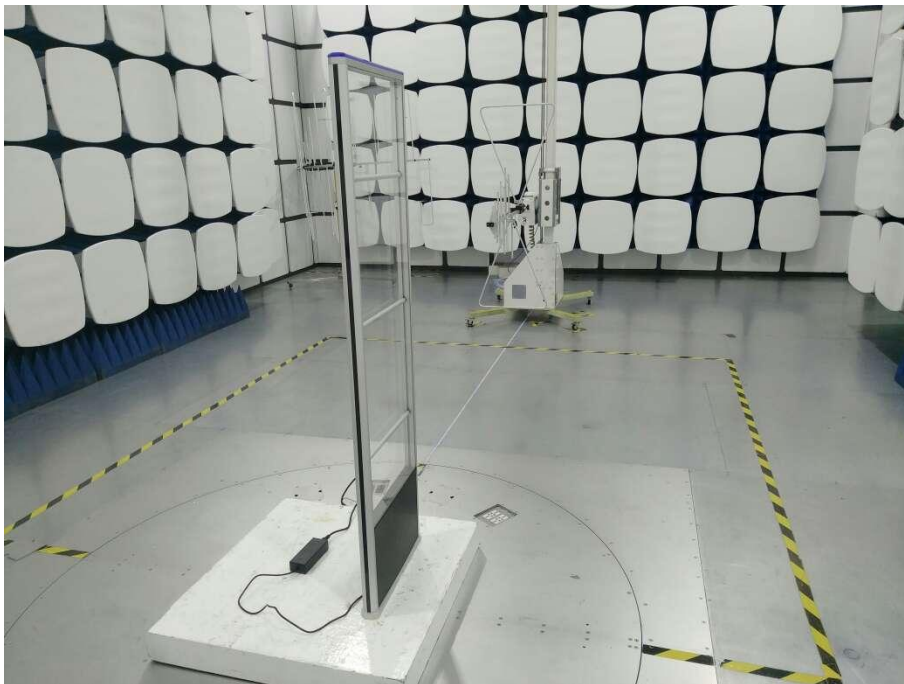

## Photographs-Conducted Emission Test Setup



## 8. Photos of EUT









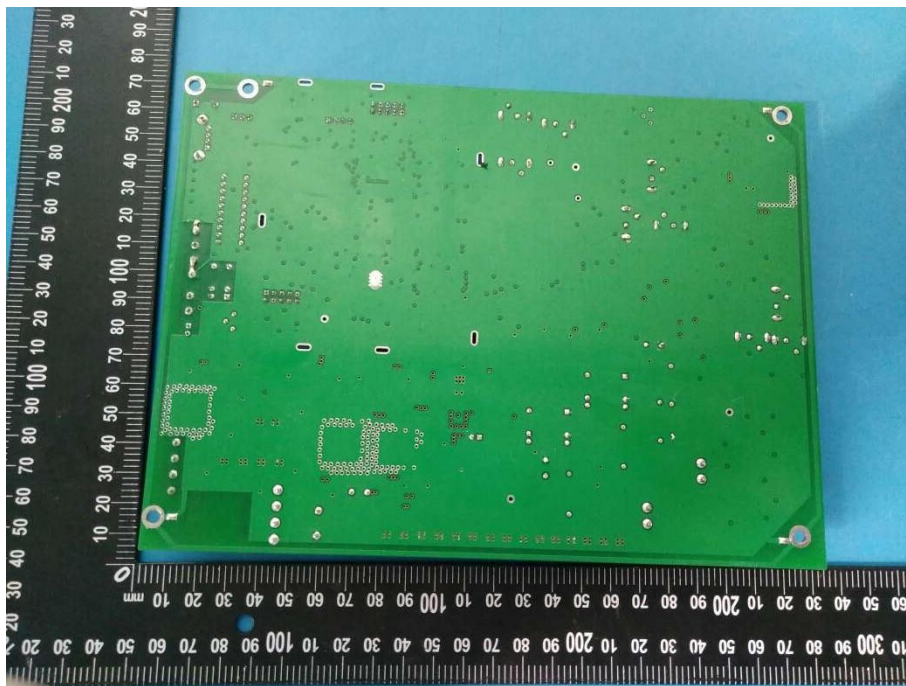
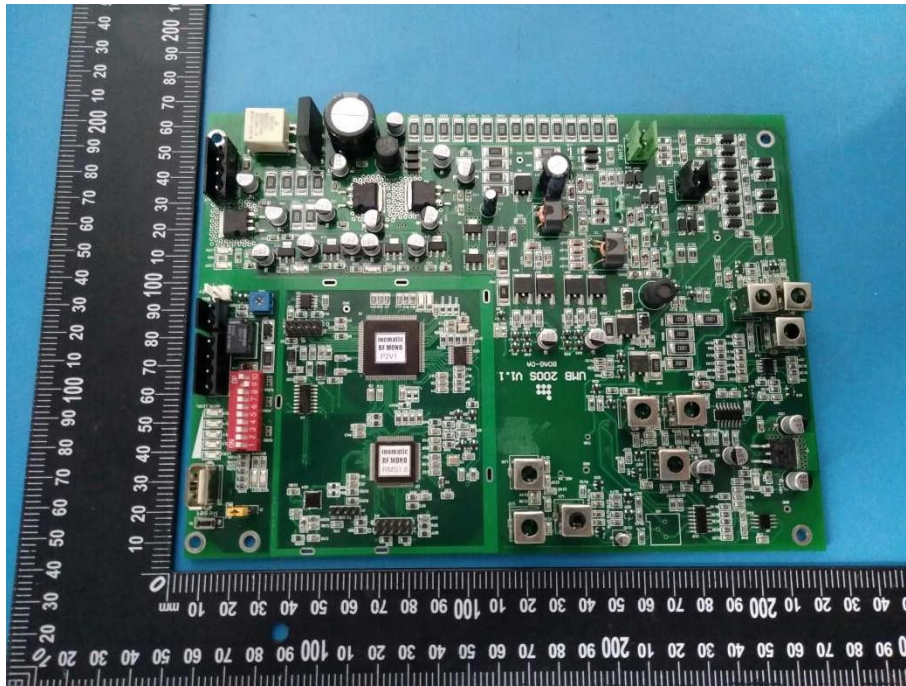

-----END OF THE REPORT-----