

# Dog Training Collar

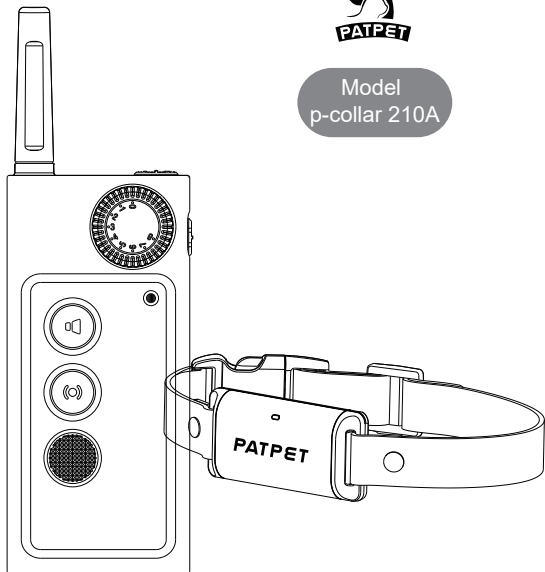

Model  
p-collar 210A



User Manual

0.3.0.02.210XXX-LH-01

# Package Contents

---

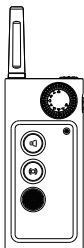

① Hand Remote Control

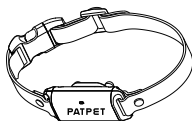

② Receiver Collar

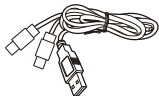

③ Charging Cable



④ Wrist Strap



⑤ User Manual

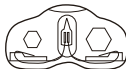

⑥ Test Light Tool



⑦ Contact Points x4



⑧ Silicone Caps x4



⑨ Contact Spring Sheet

# Overview

## Hand Remote Control

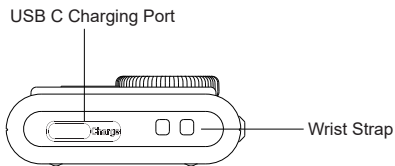
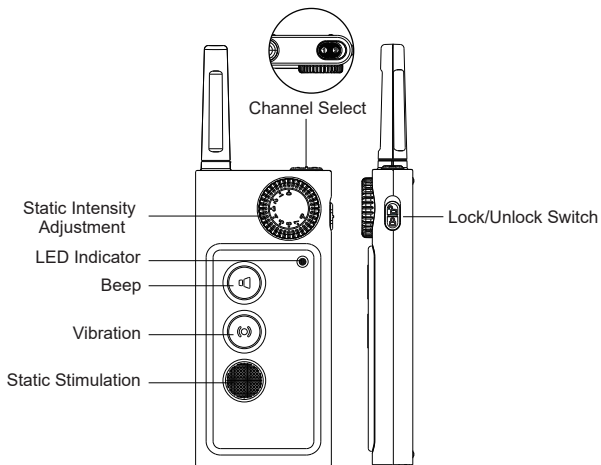

# Overview

---

## Receiver Collar

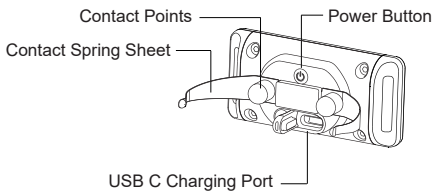
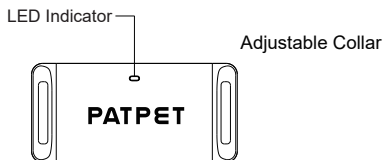

# Important Safety Information

---

This is the safety alert symbol. It is used to alert you to potential injury hazards. Obey all safety messages that follow this symbol to avoid possible injury.

## WARNING

Not for use with aggressive dogs. Do not use this product if your dog is prone to aggressive behavior. Aggressive dogs can cause severe injury to their owners and others. If you are not sure if this product is right for your dog, please check with your veterinarian or a certified trainer.

## CAUTION

### **Safety during on-leash training.**

While learning during on-leash training. Your dog should be on a strong leash, long enough for him to attempt to chase an object, but short enough for him not to reach a road or other unsafe area. You must also be physically strong enough to restrain your dog when he tries to chase.

### **Risk of skin damage.**

A collar worn for too long or made too tight on the pet's neck may cause skin damage ranging from redness to pressure ulcers. This condition is commonly known as bed sores.

- Avoid leaving the collar on the dog for more than 8 hours per day.
- When possible reposition the collar on the pet's neck every 1-2 hours.
- Never connect a lead to the electronic collar, it will cause excessive pressure on the contacts.
- If a rash or sore is found, discontinue use of the collar until the skin has healed.
- If the condition persists beyond 48 hours, see your veterinarian.
- This product is not a toy, please keep away from children.
- This product is only for use with healthy dogs over 6-month old.

## 01 Charge The Remote And Receiver Collar

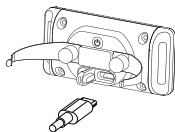

USB Charging Port

When charging is completed, steady green light.

## 02 Turn On The Remote

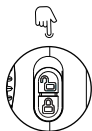

Flick down to lock the remote.



Flick up to unlock the remote.

### 03 Turn On The Receiver Collar

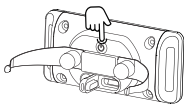

Click the power button to turn on the receiver collar, the receiver collar vibrates 1 time and the green LED flashes 1 time. Press and hold the power button for 2 secs to turn off the receiver collar, the receiver collar vibrates twice and red LED flashes twice.  
**Note:** To extend the battery life, please turn the receiver collar off when it is not in use.

### 04 Assemble the Receiver

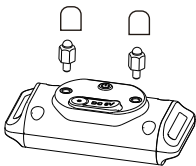

For dog with thin coats

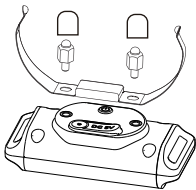

For dog with thicker coats

**Note:** For dog with shorter coats use 2pcs contact points and install the conductive silicone caps onto the contact points to make it softer, it may be better for your dog's skin. For dog with thicker coats, please install contact spring sheet.

## 05 Fit The Receiver Collar



The contact points must have direct contact with the dog's neck skin. Check the tightness of the collar by inserting one finger snugly between the collar and neck.

## 06 Beep

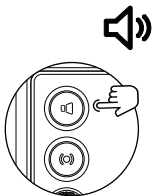
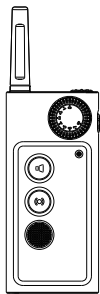

Delivers a beep tone with non-adjustable volume to the receiver collar.



## 07 Vibration

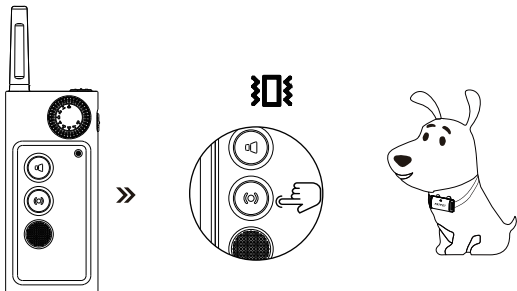

Delivers a vibration with non-adjustable level to the receiver collar.

## 08 Static Stimulation

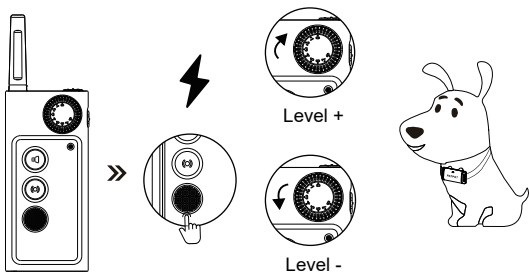

Delivers currently selected level static stimulation to the receiver collar.  
Note: Please use with caution static stimulation, some dogs may not respond to lower levels. See the "How To Find The Best Static Level For Your Dog"(Page 8). "0" means none, "8" means the highest level.

## 09 How To Find The Best Static Level For Your Dog

**Very Important:** Always start at the lowest level and choose the level that is best for your dog.

### **Follow the steps below to find the best Level:**

1. Starting at Level 1, press the static button to see the dog's reaction.
2. Gradually increase the stimulation levels until your pet reliably responds to the stimulation.
3. If your dog continues showing no response at Level 3, check the fit of the receiver collar. If your dog has long or thick hair, install contact spring sheet, or dog's hair will need to be trimmed around the contact points. If the "Contact Points" is no contact with the dog's skin, there will be no static stimulation.

**Note:** If all of these steps have been done and the dog continues showing no reaction, see the "How to Use Test Light Tool"(Page 11).

# Main Features

---



Seep, Vibration and Static training mode



0-8 adjustable static level



Receiver collar is IP67 waterproof (Caution: Remote non-waterproof)



Remote range is 300-1000 feet



Long-life rechargeable lithium polymer battery



Support maximum 2 receiver collars with 1 remote



USB C charging port

# How to Use Test Light Tool

1. Make sure the Remote and Receiver Collar are on paired.
2. Put the test light tool vertically on the 2 contact points, making sure the metal wire has direct contact with the top of the 2 points.
3. Press the static button on the remote. The test light will be lighted.  
The higher the static level is the redder the light will be.

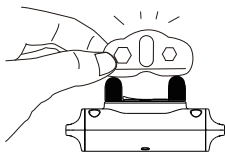

**Note:** For dog with shorter coats use 2pcs contact points and install the conductive silicone caps onto the contact points to make it softer, it may be better for your dog's skin. For dog with thicker coats, please install contact spring sheet.

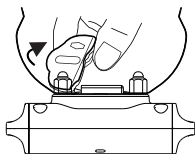
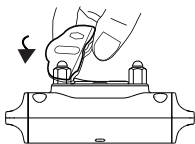
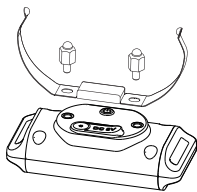
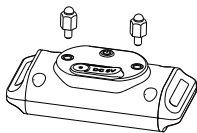

# Training Tips

---

**If you want to correct the dog's bad behavior, for example, barking, please follow these training steps.**

1. Put a separate non-metallic collar on your dog's neck above the receiver collar, and attach an 8-10 feet leash.

Caution: Be sure the extra collar does not put pressure on the contact points.

2. Hold the leash and the remote.

3. Choose your pet's recognition static level.

4. As soon as your pet is barking, press the stimulation button and give the command "No" or "No barking."

5. Release the stimulation button immediately once your dog stops barking and praise it.

6. If your pet ignores the stimulation, increase the Intensity Level by 1 to 3.

7. Practice this training in several different scenes.

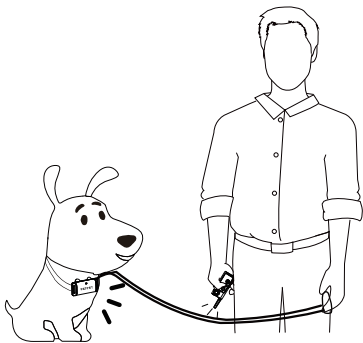

# Pairing

---

Note: You may skip this step because the set is already paired by factory setting.

1. Make sure the receiver collar is turned off, make sure the channel switch of remote is on "Dog 1".
2. Press and hold the power button of receiver collar for 3 secs until the red and green lights flash alternately.

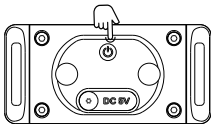

3. Press and hold the Beep and Vibration buttons of remote at the same time to pair the receiver collar.

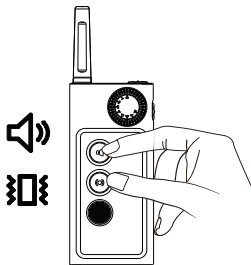

4. Pairing successful, the receiver collar beeps 3 times and the green light flashes 3 times.



# Two Receiver Collars System

---

## Part I : Pairing 2nd Receiver Collar.

**Note:** You need own an additional receiver collar.

1. Make sure the receiver collar is turned off, make sure the channel switch of remote is on "Dog 2".
2. Press and hold the power button of receiver collar for 3 secs until the red and green lights flash alternately.
3. Press and hold the Beep and Vibration buttons of remote at the same time to pair the receiver collar.
4. Pairing successful, the receiver collar beeps 3 times and the green light flashes 3 time.

## Part II : Receiver Switching.

Able to train 2 dogs separately. Regulator channel switch select the dog to train.

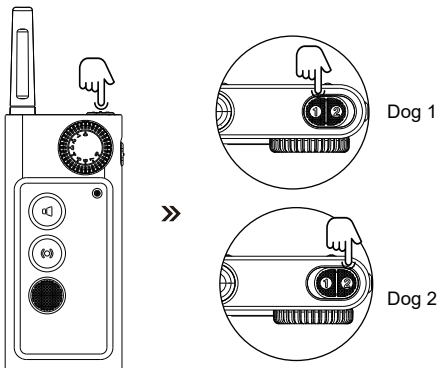

# Question & Answer

---

Q: Is the static safe for my pet?

A: Static electricity may hurt your pet, please select the appropriate static electricity level. Electronic training equipment requires the interaction and training of the owner.

Q: How old does my pet have to be before using the electronic training collar?

A: Your pet should be able to recognize basic obedience commands such as "Sit" or "Stay". Pets should be at least 6 months old before using the training collar.

Q: Once my pet is trained and has been obeying my commands, will he have to continue to wear the receiver collar?

A: It is recommended to wear it until you completely correct the dog's bad behavior.

Q: Is the receiver collar waterproof?

A: Yes, the receiver collar is IP67 waterproof. But the remote is not waterproof. Please keep the remote away from water.

Q: Will I get exactly 1000 feet of range with the electronic training collar?

A: The effective wireless communication range will be affected by terrain, weather, vegetation, and interference from other radio equipment.

Q: How can I get support when I have product problems?

A: Please feel free to contact our official customer service mailbox, any problems about the product will be resolved here ✉ [service@patpet.com](mailto:service@patpet.com).



# Troubleshooting

---

My pet does not respond when i press a button.

1. Make sure the receiver collar has been turned on.
2. Make sure the remote channel 1 or 2 is correct with the receiver collar. If not, please pairing the remote and the receiver collar again. Refer to "Pairing" (Page 12) for more information.
3. Check the battery may be low in either the remote or the receiver collar.
4. Make sure the receiver collar's contact points are placed snugly against your pet's skin. Refer to "Fit The Receiver Collar" (Page 6) for more information.
5. Terrain, weather, vegetation, transmission from other radio devices, and many other factors can impact the amount of range you have with the unit.

# Warranty

---

## 1-Year Warranty

The original purchaser for this unit is provided with a 1-YEAR Warranty. The warranty begins on the date of purchase. For the first year, coverage is provided for both parts and labor on warranty repair services. After the first year, the Limited Lifetime Warranty covers parts only, and does not cover labor fees and Accessories. Accessories such as straps and batteries are covered for the first year only. All shipping fees incurred, the cost of accessories after the first year, and labor fees associated with out of warranty repair work are the customers responsibility.

## Not Covered Under Warranty

We DO NOT offer warranty for products that have been bought secondhand or were resold. Issues of replacement and refunds on units purchased less than 30 days from an authorized dealer must be addressed to the dealer directly. If the products purchased from an authorized dealer are after 30 days from the date of purchase, please send the units to us for service and repair.

We DO NOT cover the cost of repairs and replacements due to misuse by the owner or dog, improper maintenance, and/or lost units. The warranty is void if the unit has been altered or an unauthorized person has damaged the unit while attempting repair work.

## Procedure for Repair Work

### **Safety during on-leash training.**

If the unit is malfunctioning, please refer to the "Troubleshooting" in the manual before sending it back for service. A copy of the sales receipt showing the purchase date may be required before warranty work is initiated. Please include a brief explanation outlining the problem, and include your name, address,city/state/zip code, daytime phone number, evening phone number, and email address.

# Compliance FCC - USA

---

This device complies with part 15 of the FCC rules. Operation is subject to the following two conditions:

1. This device may not cause harmful interference.
2. This device must accept any interference received, including interference that may cause undesired operation.

**CAUTION: Modification or changes to this equipment not expressly approved by the manufacturer may void the user's authority to operate the equipment.**

Note: This equipment has been tested and found to comply with the limits for a Class B digital device, pursuant to part 15 of the FCC Rules. These limits are designed to provide reasonable protection against harmful interference in a residential installation. This equipment generates uses and can radiate radio frequency energy, if not installed and used in accordance with the instructions, may cause harmful interference to radio communications. However, there is no guarantee that interference will not occur in a particular installation. If this equipment does cause harmful interference to radio or television reception, which can be determined by turning the equipment off and on, the user is encouraged to try to correct the interference by one or more of the following measures:

1. Reorient or relocate the receiving antenna.
2. Increase the separation between the equipment and receiver.
3. Connect the equipment into an outlet on a circuit different from that to which the receiver is connected.
4. Consult the dealer or an experienced radio/TV technician for help.



Designed By PATPET



<https://patpet.us>



[service@patpet.com](mailto:service@patpet.com)



@PATPET



1-855-888-9922 (Mon-Fri, EST 9:00-17:00)

Shenzhen Patpet Technology Co., Ltd  
Add: No. 59-63, The 2nd Industrial Park,  
Houting, Shajing Street, Baoan District,  
Shenzhen, China



MADE IN CHINA