



Test Report

FCC ID: 2AHGU-H1

Date of issue: Nov. 06, 2017

Report Number:	CF17111306
Sample Description:	ACIL H1
Model(s):	H1
Applicant:	Fengfan (Suzhou) Audio Technology Co., Ltd
Address:	E1-101, No.88 Dongchang Rd (i-Park), SIP Suzhou, Jiangsu Province, China (PRC)
Date of Test:	Oct. 09, 2017 to Nov. 06, 2017



TEST RESULT CERTIFICATION

TEST RESULT CERTIFICATION	
Applicant's name	Fengfan (Suzhou) Audio Technology Co., Ltd
Address	E1-101, No.88 Dongchang Rd (i-Park), SIP Suzhou, Jiangsu Province, China (PRC)
Manufacture's Name	Jiangxi Lianchuang Hongsheng Electronics Co., Ltd
Address	No.1699 Jingdong Ave.High-Tech Distict, Nanchang City,Jiangxi Province, China
Product name	ACIL H1
Model and/or type reference :	H1
Serial Model.....	N/A
Standards	FCC Part15.247
Test procedure.....	ANSI C63.10:2013

This device described above has been tested by WH Technology Corp. and the test results show that the equipment under test (EUT) is in compliance with the FCC requirements. And it is applicable only to the tested sample identified in the report.

Tested by:

Bell Wei

Nov. 17, 2017

Approved by:

Mike Lee

Nov. 17, 2017



Table of Contents

	Page
1 . SUMMARY OF TEST RESULTS	6
1.1 TEST FACILITY	7
1.2 MEASUREMENT UNCERTAINTY	7
2 . GENERAL INFORMATION	8
2.1 GENERAL DESCRIPTION OF EUT	8
2.2 DESCRIPTION OF TEST MODES	10
2.3 BLOCK DIGRAM SHOWING THE CONFIGURATION OF SYSTEM TESTED	11
2.4 DESCRIPTION OF SUPPORT UNITS(CONDUCTED MODE)	12
2.5 EQUIPMENTS LIST FOR ALL TEST ITEMS	13
3 . EMC EMISSION TEST	14
3.1 CONDUCTED EMISSION MEASUREMENT	14
3.1.1 POWER LINE CONDUCTED EMISSION LIMITS	14
3.1.2 TEST PROCEDURE	15
3.1.3 DEVIATION FROM TEST STANDARD	15
3.1.4 TEST SETUP	15
3.1.5 EUT OPERATING CONDITIONS	15
3.1.6 TEST RESULTS	16
3.2 RADIATED EMISSION MEASUREMENT	18
3.2.1 RADIATED EMISSION LIMITS	18
3.2.2 TEST PROCEDURE	18
3.2.3 DEVIATION FROM TEST STANDARD	19
3.2.4 TEST SETUP	20
3.2.5 EUT OPERATING CONDITIONS	21
3.2.6 TEST RESULTS (BETWEEN 9KHZ – 30 MHZ)	22
3.2.7 TEST RESULTS (BETWEEN 30MHZ – 1GHZ)	23
3.2.8 TEST RESULTS (1G-25GHZ)	25
3.3 BAND EDGE(RADIATED)	27
BAND EDGE(RADIATED)(HOPPING MODE)	28
4 . 20DB OCCUPY BANDWIDTH	29
4.1 APPLIED PROCEDURES / LIMIT	29
4.1.1 TEST PROCEDURE	29
4.1.2 DEVIATION FROM STANDARD	29
4.1.3 TEST SETUP	29



Table of Contents

	Page
4.1.4 EUT OPERATION CONDITIONS	29
4.1.5 TEST RESULTS	30
5 . CARRIER FREQUENCY SEPARATION TEST	36
5.1 APPLIED PROCEDURES / LIMIT	36
5.1.1 TEST PROCEDURE	36
5.1.2 DEVIATION FROM STANDARD	36
5.1.3 TEST SETUP	36
5.1.4 EUT OPERATION CONDITIONS	36
5.1.5 TEST RESULTS	37
6 . NUMBER OF HOPPING CHANNEL	39
6.1 APPLIED PROCEDURES / LIMIT	39
6.1.1 TEST PROCEDURE	39
6.1.2 DEVIATION FROM STANDARD	39
6.1.3 TEST SETUP	39
6.1.4 EUT OPERATION CONDITIONS	39
6.1.5 TEST RESULTS	39
7 . DWELL TIME	42
7.1 APPLIED PROCEDURES / LIMIT	42
7.1.1 TEST PROCEDURE	42
7.1.2 DEVIATION FROM STANDARD	42
7.1.3 TEST SETUP	42
7.1.4 EUT OPERATION CONDITIONS	42
7.1.5 TEST RESULTS	43
8 . PEAK OUTPUT POWER TEST	50
8.1 APPLIED PROCEDURES / LIMIT	50
8.1.1 TEST PROCEDURE	50
8.1.2 DEVIATION FROM STANDARD	50
8.1.3 TEST SETUP	50
8.1.4 EUT OPERATION CONDITIONS	50
8.1.5 TEST RESULTS	51
GFSK 2402MHZ	52
8.1.7 DEVIATION FROM STANDARD	57
8.1.8 TEST SETUP	57
8.1.9 EUT OPERATION CONDITIONS	58
8.1.10 TEST RESULTS	59



Table of Contents

	Page
9 . ANTENNA REQUIREMENT	67
9.1 STANDARD REQUIREMENT	67
9.2 EUT ANTENNA	67



1. SUMMARY OF TEST RESULTS

Test procedures according to the technical standards:

FCC Part15 (15.247) , Subpart C			
Standard Section	Test Item	Judgment	Remark
15.203/15.247(c)	Antenna Requirement	PASS	
15.207	Conducted Emission	PASS	
15.247(b)(1)	Conducted Peak Output Power	PASS	
15.247(a)(1)	20dB Occupied Bandwidth	PASS	
15.247(a)(1)	Carrier Frequencies Separation	PASS	
15.247(a)(1)	Hopping Channel Number	PASS	
15.247(a)(1)	Dwell Time	PASS	
15.205/15.209	Spurious Emission	PASS	
15.247(d)	Band Edge	PASS	

NOTE:

(1) "N/A" denotes test is not applicable in this Test Report



1.1 TEST FACILITY

WH Technology Corp.

Add.: 7F., No.262, Sec. 3, Datong Rd., Xizhi Dist., New Taipei City 221, Taiwan (R.O.C.)

FCC Registration No.: TW1083

1.2 MEASUREMENT UNCERTAINTY

The reported uncertainty of measurement $y \pm U$ where expanded uncertainty U is based on a standard uncertainty multiplied by a coverage factor of $k=2$ providing a level of confidence of approximately **95 %**.

No.	Item	Uncertainty
1	Conducted Emission Test	$\pm 1.38\text{dB}$
2	RF power,conducted	$\pm 0.16\text{dB}$
3	Spurious emissions,conducted	$\pm 0.21\text{dB}$
4	All emissions,radiated(<1G)	$\pm 4.68\text{dB}$
5	All emissions,radiated(>1G)	$\pm 4.89\text{dB}$
6	Temperature	$\pm 0.5^\circ\text{C}$
7	Humidity	$\pm 2\%$



2. GENERAL INFORMATION

2.1 GENERAL DESCRIPTION OF EUT

Equipment	ACIL H1	
Trade Name	ACIL	
Model Name	H1	
Serial Model	N/A	
Model Difference	N/A	
Product Description	The EUT is a ACIL H1	
	Operation Frequency:	2402-2480MHz
	Modulation Type:	GFSK, π/4-DQPSK, 8-DPSK
	Bit Rate of Transmitter	1,2,3Mbps
	Number Of Channel	79 CH
	Antenna Designation:	Please see Note 3.
	Output Power(Conducted):	1.96 dBm
	Antenna Type:	Chip antenna
	Antenna Gain (dBi)	2 dBi
Based on the application, features, or specification exhibited in User's Manual, the EUT is considered as an ITE/Computing Device. More details of EUT technical specification, please refer to the User's Manual.		
Channel List	Please refer to the Note 2.	
Battery	DC 3.7V 137mAh	
Connecting I/O Port(s)	Please refer to the User's Manual	

Note:

- For a more detailed features description, please refer to the manufacturer's specifications or the User's Manual.
- Channel List

Channel	Frequency (MHz)	Channel	Frequency (MHz)	Channel	Frequency (MHz)
00	2402	27	2429	54	2456
01	2403	28	2430	55	2457
02	2404	29	2431	56	2458
03	2405	30	2432	57	2459
04	2406	31	2433	58	2460
05	2407	32	2434	59	2461
06	2408	33	2435	60	2462
07	2409	34	2436	61	2463
08	2410	35	2437	62	2464



09	2411	36	2438	63	2465
10	2412	37	2439	64	2466
11	2413	38	2440	65	2467
12	2414	39	2441	66	2468
13	2415	40	2442	67	2469
14	2416	41	2443	68	2470
15	2417	42	2444	69	2471
16	2418	43	2445	70	2472
17	2419	44	2446	71	2473
18	2420	45	2447	72	2474
19	2421	46	2448	73	2475
20	2422	47	2449	74	2476
21	2423	48	2450	75	2477
22	2424	49	2451	76	2478
23	2425	50	2452	77	2479
24	2426	51	2453	78	2480
25	2427	52	2454		
26	2428	53	2455		
Remark: Channel 0, 39 & 78 selected for GFSK, $\pi/4$ -DQPSK and 8DPSK.					

3. Table for Filed Antenna

Ant	Brand	Model Name	Antenna Type	Connector	Gain (dBi)	NOTE
A	ACIL	H1	Chip antenna	/	2	Chip Antenna



2.2 DESCRIPTION OF TEST MODES

To investigate the maximum EMI emission characteristics generates from EUT, the test system was pre-scanning tested base on the consideration of following EUT operation mode or test configuration mode which possible have effect on EMI emission level. Each of these EUT operation mode(s) or test configuration mode(s) mentioned above was evaluated respectively.

Pretest Mode	Description
Mode 1	GFSK CH1/CH40/CH79
Mode 2	$\pi/4$ -DQPSK CH1/CH40/CH79
Mode 3	8-DPSK CH1/CH40/CH79
Mode 4	Link Mode

For Conducted Emission	
Final Test Mode	Description
Mode 4	Link Mode

For Radiated Emission	
Final Test Mode	Description
Mode 1	GFSK CH1/CH40/CH79
Mode 2	$\pi/4$ -DQPSK CH1/CH40/CH79
Mode 3	8-DPSK CH1/CH40/CH79

Note:

- (1) The measurements are performed at the highest, middle, lowest available channels.
- (2) The measurements are performed at all Bit Rate of Transmitter, the worst data was reported



2.3 BLOCK DIGRAM SHOWING THE CONFIGURATION OF SYSTEM TESTED

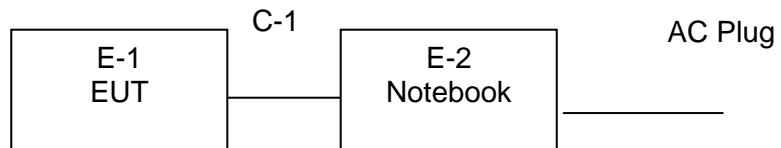



2.4 DESCRIPTION OF SUPPORT UNITS(CONDUCTED MODE)

The EUT has been tested as an independent unit together with other necessary accessories or support units. The following support units or accessories were used to form a representative test configuration during the tests.

Item	Equipment	Brand	Model/Type No.	Series No.	Note
E-1	ACIL H1	ACIL	H1	N/A	EUT
E-2	Notebook	N/A	Notebook	N/A	

Item	Shielded Type	Ferrite Core	Length	Note
C-1	NO	NO	1.0m	

Note:

- (1) The support equipment was authorized by Declaration of Confirmation.
- (2) For detachable type I/O cable should be specified the length in cm in 『Length』 column.



2.5 EQUIPMENTS LIST FOR ALL TEST ITEMS

For RF conducted test:

Equipment	Manufacturer	Model	Serial No.	Calibration Due
Universal Radio Communication Tester	Rohde&schwarz	CMU200	114587	2018/11/4
Spectrum analyzer	Agilent	E4407B	MY41441082	2018/11/4
Dc Power Supply	GW	GPR-6030D	/	2018/11/4
Temperature & Humidity Chamber	GIANT FORCE	GTH-056P	GF-94454-1	2018/11/14
Broadband TRILOG Antenna	Schwarabeck	VULB9163	9163-872	2018/11/14
Horn Antenna	Schwarzbeck	BBHA 9120 D	9120D-1145	2018/11/14
Amplifier	HP	8447D	3113A06150	2018/11/4
Amplifier	Agilent	8449B	3008A02400	2018/7/4
Test Receiver	Schwarabeck	ESPI7	100314	2018/11/4
Spectrum analyzer	Agilent	E4407B	MY41441082	2018/11/4
Signal Generator	R&S	SMT 06	832080/007	2018/11/4
Broadband TRILOG Antenna	Schwarabeck	VULB9163	9163-872	2018/11/14
Horn Antenna	Schwarzbeck	BBHA 9120 D	9120D-1145	2018/11/14
Amplifier	HP	8447D	3113A06150	2018/11/4
Amplifier	Agilent	8449B	3008A02400	2018/7/4
Test Receiver	Schwarabeck	ESPI	100314	2018/11/4
Spectrum analyzer	Agilent	E4407B	MY41441082	2018/11/4
LISN	R&S	ENV216	1001131	2018/9/25
Test Cable	United Microwave	57793	1m	2018/12/05
Test Cable	United Microwave	A30A30-5006	10m	2018/12/05

Note: the calibration interval of the above test instruments is 12 months and the calibrations are traceable to international system unit (SI).



3. EMC EMISSION TEST

3.1 CONDUCTED EMISSION MEASUREMENT

3.1.1 POWER LINE CONDUCTED EMISSION Limits (Frequency Range 150KHz-30MHz)

Frequency (MHz)	Limit	
	Quasi-peak	Average
0.15-0.5	66 to 56	56 to 46
0.5-5	56	46
5-30	60	50

Note:

(1) Decreases with the logarithm of the frequency from 0.15MHz to 0.5MHz.

1.1.1 Test method

1. The EUT was placed 0.8 meters from the horizontal ground plane with EUT being connected to the power mains through a line impedance stabilization network (LISN). All other support equipment powered from additional LISN(s). The LISN provide 50 Ohm/50uH of coupling impedance for the measuring instrument.
2. Interconnecting cables that hang closer than 40 cm to the ground plane shall be folded back and forth in the center forming a bundle 30 to 40 cm long.
3. I/O cables that are not connected to a peripheral shall be bundled in the center. The end of the cable may be terminated, if required, using the correct terminating impedance. The overall length shall not exceed 1 m.
4. LISN is at least 80 cm from nearest part of EUT chassis.
5. The resolution bandwidth of EMI test receiver is set at 9kHz.

1.1.2 Test Result

Not application because of the EUT is power by battery.

The following table is the setting of the receiver

Receiver Parameters	Setting
Attenuation	10 dB
Start Frequency	0.15 MHz
Stop Frequency	30 MHz
IF Bandwidth	9 kHz



3.1.2 TEST PROCEDURE

- a. The EUT was placed 0.8 meters from the horizontal ground plane with EUT being connected to the power mains through a line impedance stabilization network (LISN). All other support equipments powered from additional LISN(s). The LISN provide 50 Ohm/ 50uH of coupling impedance for the measuring instrument.
- b. Interconnecting cables that hang closer than 40 cm to the ground plane shall be folded back and forth in the center forming a bundle 30 to 40 cm long.
- c. I/O cables that are not connected to a peripheral shall be bundled in the center. The end of the cable may be terminated, if required, using the correct terminating impedance. The overall length shall not exceed 1 m.
- d. LISN at least 80 cm from nearest part of EUT chassis.
- e. For the actual test configuration, please refer to the related Item –EUT Test Photos.

3.1.3 DEVIATION FROM TEST STANDARD

No deviation

3.1.4 TEST SETUP

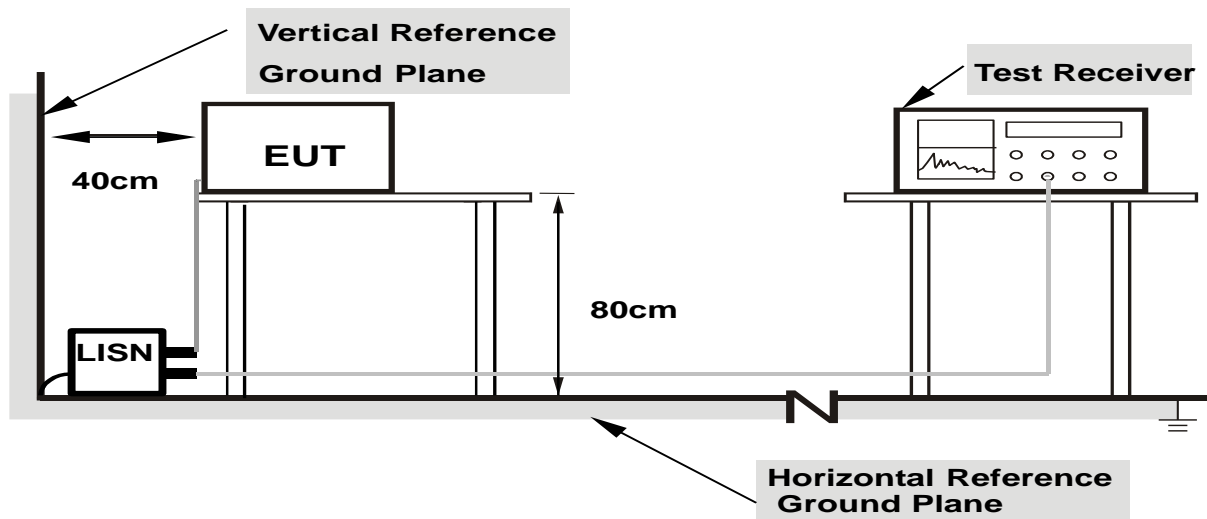

Note: 1.Support units were connected to second LISN.

2.Both of LISNs (AMN) are 80 cm from EUT and at least 80 from other units and other metal planes

3.1.5 EUT OPERATING CONDITIONS

The EUT was configured for testing in a typical fashion (as a customer would normally use it). The EUT has been programmed to continuously transmit during test. This operating condition was tested and used to collect the included data.



3.1.6 TEST RESULTS

EUT :	ACIL H1	Model Name. :	H1
Temperature :	26 °C	Relative Humidity :	54%
Pressure :	1010hPa	Phase :	L
Test Voltage :	DC 5V from USB Port or AC 120V/60Hz	Test Mode :	Mode 4

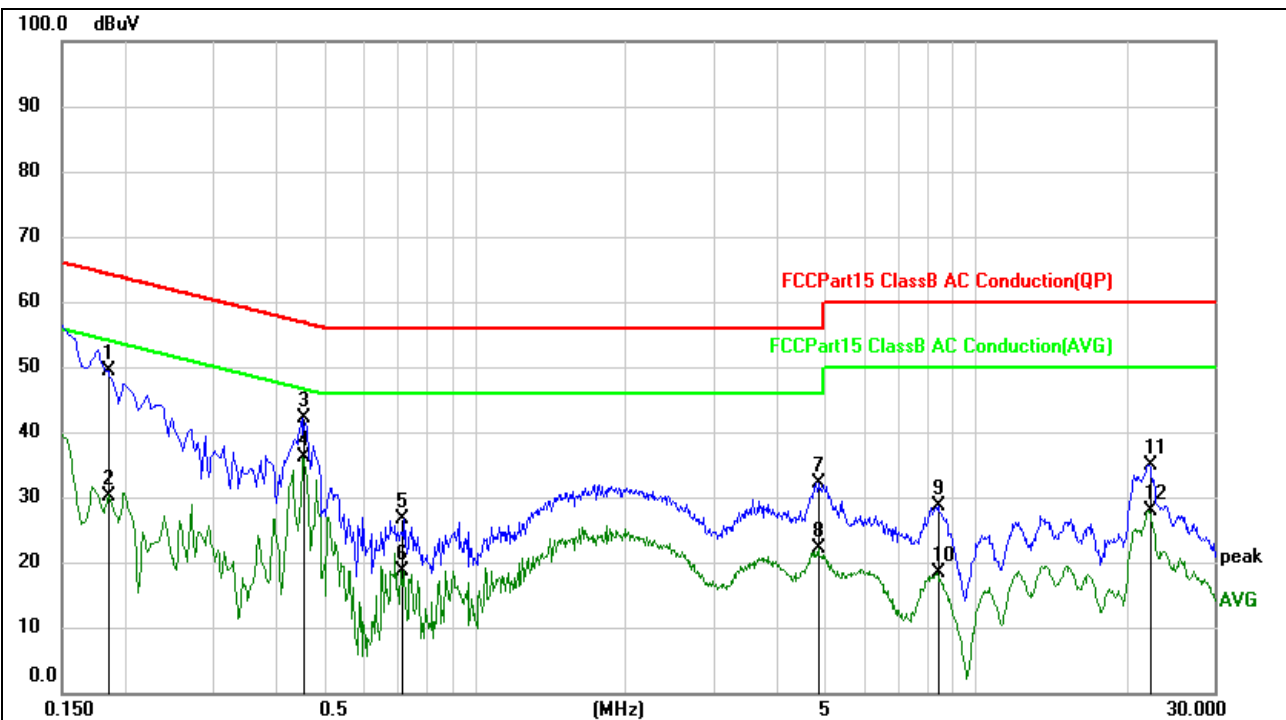

No. Mk.	Freq. MHz	Reading Level dBuV	Correct Factor dB	Measurement dBuV	Limit dBuV	Over dB	Detector	Comment
1	0.1860	49.53	-0.03	49.50	64.21	-14.71	QP	
2	0.1860	30.28	-0.03	30.25	54.21	-23.96	AVG	
3	0.4560	42.27	-0.03	42.24	56.77	-14.53	QP	
4 *	0.4560	36.09	-0.03	36.06	46.77	-10.71	AVG	
5	0.7125	26.67	-0.03	26.64	56.00	-29.36	QP	
6	0.7125	18.59	-0.03	18.56	46.00	-27.44	AVG	
7	4.8705	32.15	-0.06	32.09	56.00	-23.91	QP	
8	4.8705	22.28	-0.06	22.22	46.00	-23.78	AVG	
9	8.3715	28.61	-0.07	28.54	60.00	-31.46	QP	
10	8.3715	18.36	-0.07	18.29	50.00	-31.71	AVG	
11	22.1955	35.20	-0.29	34.91	60.00	-25.09	QP	
12	22.1955	28.19	-0.29	27.90	50.00	-22.10	AVG	



EUT :	ACIL H1	Model Name. :	H1
Temperature :	26 °C	Relative Humidity :	54%
Pressure :	1010hPa	Phase :	N
Test Voltage :	DC 5V from USB Port or AC 120V/60Hz	Test Mode :	Mode 4

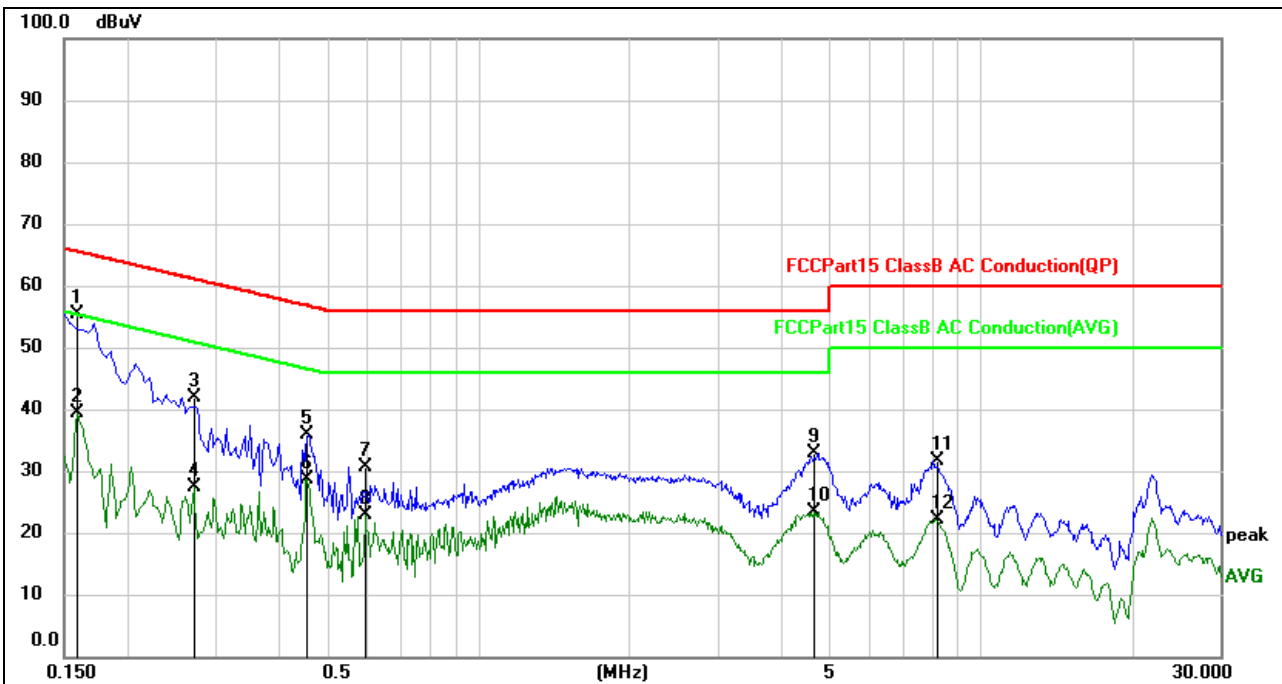

No.	Mk.	Freq. MHz	Reading Level dBuV	Correct Factor dB	Measurement dBuV	Limit dBuV	Over dB	Detector	Comment
1	*	0.1590	55.39	-0.04	55.35	65.52	-10.17	QP	
2		0.1590	39.42	-0.04	39.38	55.52	-16.14	AVG	
3		0.2714	41.85	-0.03	41.82	61.07	-19.25	QP	
4		0.2714	27.44	-0.03	27.41	51.07	-23.66	AVG	
5		0.4560	35.86	-0.03	35.83	56.77	-20.94	QP	
6		0.4560	28.61	-0.03	28.58	46.77	-18.19	AVG	
7		0.5955	30.68	-0.03	30.65	56.00	-25.35	QP	
8		0.5955	22.91	-0.03	22.88	46.00	-23.12	AVG	
9		4.6500	32.86	-0.06	32.80	56.00	-23.20	QP	
10		4.6500	23.33	-0.06	23.27	46.00	-22.73	AVG	
11		8.1735	31.65	-0.07	31.58	60.00	-28.42	QP	
12		8.1735	22.20	-0.07	22.13	50.00	-27.87	AVG	



3.2 RADIATED EMISSION MEASUREMENT

3.2.1 RADIATED EMISSION LIMITS (Frequency Range 9kHz-1000MHz)

20dBc in any 100 kHz bandwidth outside the operating frequency band. In case the emission fall within the restricted band specified on 15.205(a), then the 15.209(a) limit in the table below has to be followed.

Frequencies (MHz)	Field Strength (micorvolts/meter)	Measurement Distance (meters)
0.009~0.490	2400/F(KHz)	300
0.490~1.705	24000/F(KHz)	30
1.705~30.0	30	30
30~88	100	3
88~216	150	3
216~960	200	3
Above 960	500	3

Spectrum Parameter	Setting
Attenuation	Auto
Start Frequency	1000 MHz
Stop Frequency	10th carrier harmonic
RB / VB (emission in restricted band)	1 MHz / 1 MHz for Peak, 1 MHz / 10Hz for Average

Receiver Parameter	Setting
Attenuation	Auto
Start ~ Stop Frequency	9kHz~150kHz / RB 200Hz for QP
Start ~ Stop Frequency	150kHz~30MHz / RB 9kHz for QP
Start ~ Stop Frequency	30MHz~1000MHz / RB 120kHz for QP

3.2.2 TEST PROCEDURE

- The measuring distance of at 3 m shall be used for measurements at frequency up to 1GHz. For frequencies above 1GHz, any suitable measuring distance may be used.
- The EUT was placed on the top of a rotating table 0.8 meters above the ground at a 3 meter open area test site. The table was rotated 360 degrees to determine the position of the highest radiation.
- The height of the equipment or of the substitution antenna shall be 0.8 m; the height of the test antenna shall vary between 1 m to 4 m. Both horizontal and vertical polarizations of the antenna are set to make the measurement.



- d. The initial step in collecting conducted emission data is a spectrum analyzer peak detector mode pre-scanning the measurement frequency range. Significant peaks are then marked and then Quasi Peak detector mode re-measured.
- e. If the Peak Mode measured value compliance with and lower than Quasi Peak Mode Limit, the EUT shall be deemed to meet QP Limits and then no additional QP Mode measurement performed.
- f. For the actual test configuration, please refer to the related Item –EUT Test Photos.

Note:

Both horizontal and vertical antenna polarities were tested and performed pretest to three orthogonal axis. The worst case emissions were reported

3.2.3 DEVIATION FROM TEST STANDARD

No deviation



3.2.4 TEST SETUP

(A) Radiated Emission Test-Up Frequency Below 30MHz

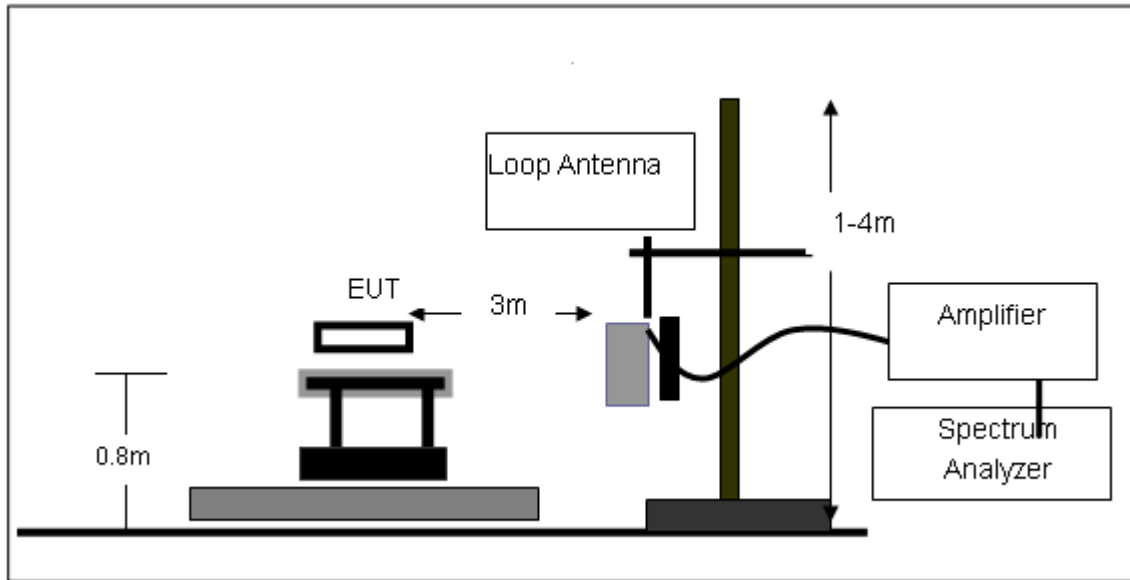

(B) Radiated Emission Test-Up Frequency 30MHz~1GHz

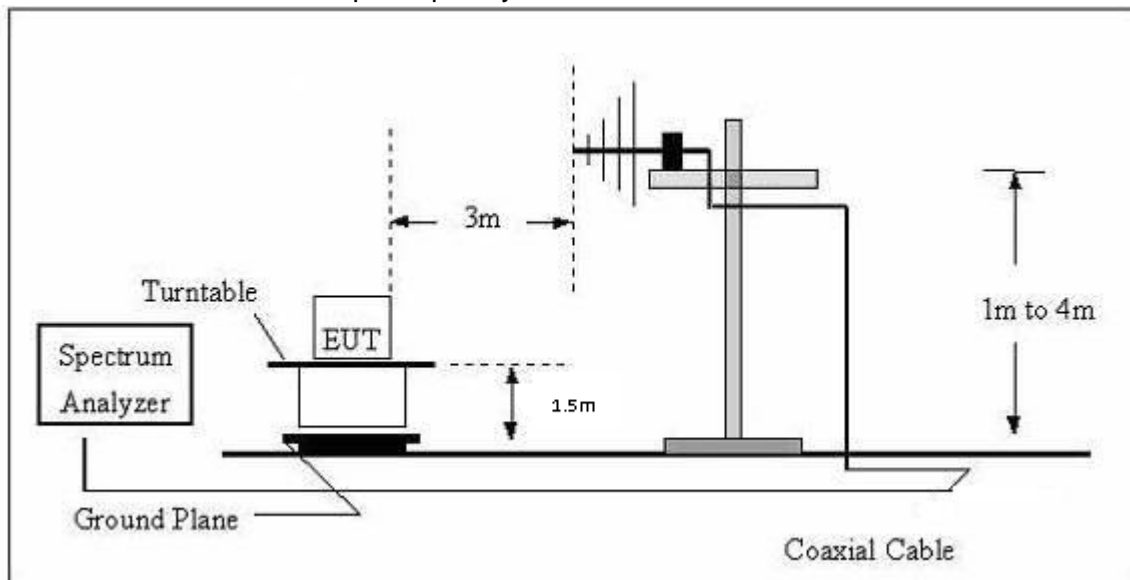



(C) Radiated Emission Test-Up Frequency Above 1GHz

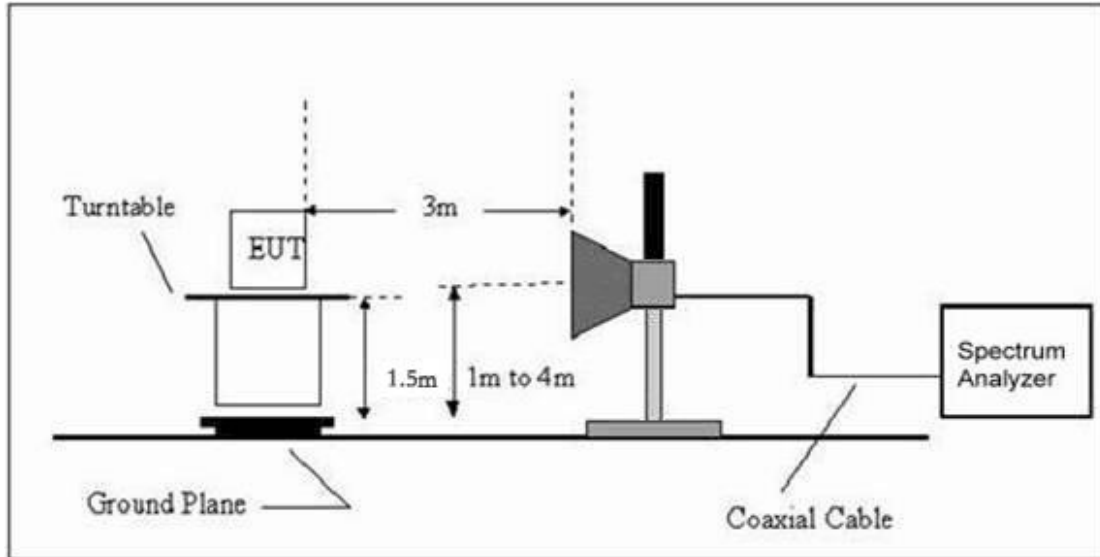

3.2.5 EUT OPERATING CONDITIONS

The EUT tested system was configured as the statements of 2.4 Unless otherwise a special operating condition is specified in the follows during the testing.



3.2.6 TEST RESULTS (BETWEEN 9KHZ – 30 MHZ)

EUT:	ACIL H1	Model Name. :	H1
Temperature:	20 °C	Relative Humidity:	48%
Pressure:	1010 hPa	Test Voltage :	DC 5V from USB Port or AC 120V/60Hz
Test Mode :	TX	Polarization :	--

Freq. (MHz)	Reading (dBuV/m)	Limit (dBuV/m)	Margin (dB)	State P/F
--	--	--	--	PASS
--	--	--	--	PASS

NOTE:

The amplitude of spurious emissions which are attenuated by more than 20dB below the permissible value has no need to be reported.

Distance extrapolation factor = $40 \log(\text{specific distance}/\text{test distance})$ (dB);

Limit line = specific limits(dBuv) + distance extrapolation factor.



3.2.7 TEST RESULTS (BETWEEN 30MHZ – 1GHZ)

EUT :	ACIL H1	Model Name :	H1
Temperature :	20 °C	Relative Humidity :	48%
Pressure:	1010 hPa	Test Voltage :	DC 5V from USB Port
Test Mode :	TX		

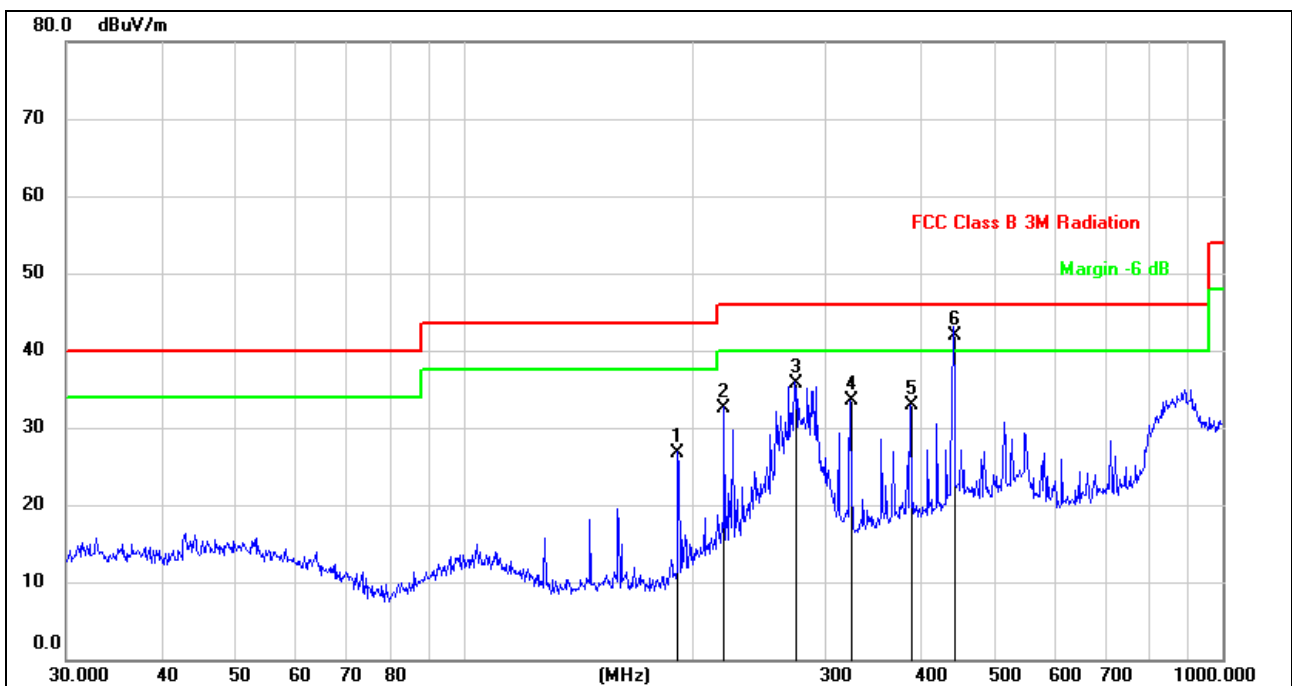

No. Mk.	Freq. MHz	Reading Level dBuV	Correct Factor dBuV/m	Measure- ment dBuV/m	Limit dBuV/m	Over dB	Antenna Height cm	Table Degree degree	Comment
1	191.7450	39.79	-12.99	26.80	43.50	-16.70	QP		
2	220.6171	43.62	-11.02	32.60	46.00	-13.40	QP		
3	273.2341	45.18	-9.38	35.80	46.00	-10.20	QP		
4	323.3204	41.64	-8.14	33.50	46.00	-12.50	QP		
5	387.9920	39.69	-6.79	32.90	46.00	-13.10	QP		
6	* 441.7426	47.94	-5.94	42.00	46.00	-4.00	QP		



EUT :	ACIL H1	Model Name :	H1
Temperature :	20 °C	Relative Humidity :	48%
Pressure:	1010 hPa	Test Voltage :	DC 5V from USB Port
Test Mode :	RX		

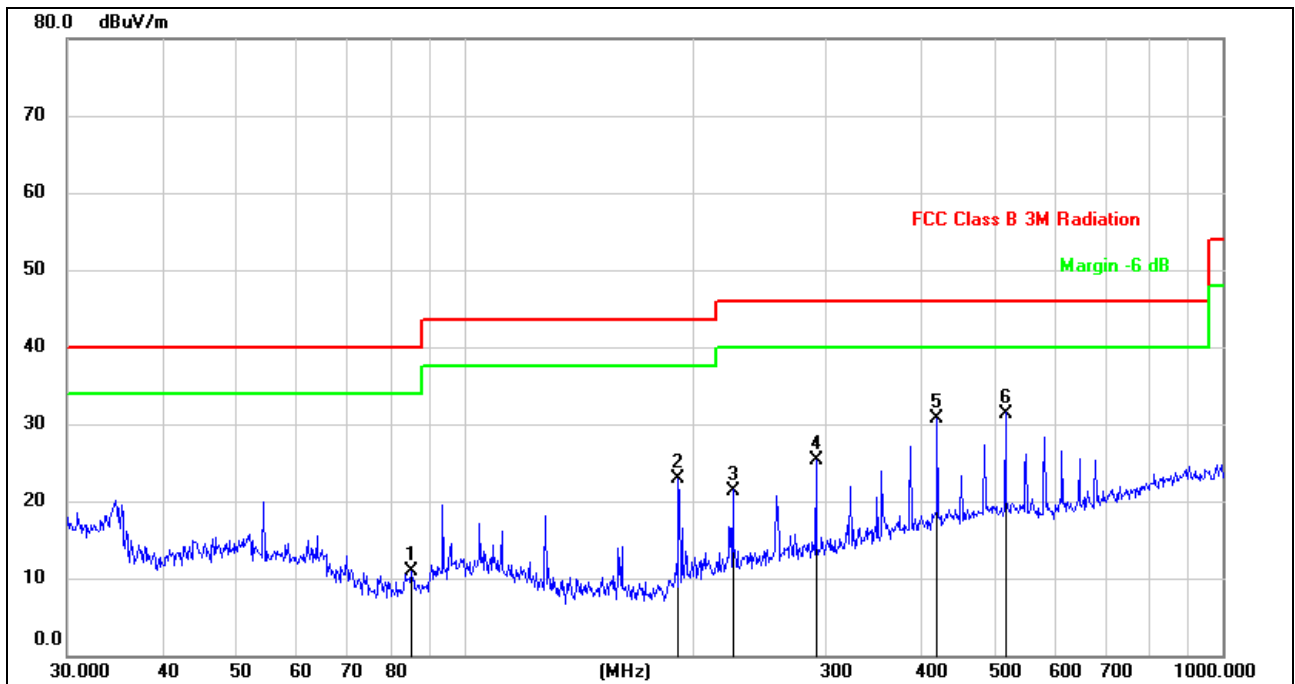

No.	Mk.	Freq.	Reading Level	Correct Factor	Measurement	Limit	Over	Antenna Height	Table Degree	
		MHz	dBuV	dBuV/m	dBuV/m	dBuV/m	dB	cm	degree	Comment
1		85.2980	25.14	-14.24	10.90	40.00	-29.10	QP		
2		191.7450	33.47	-10.57	22.90	43.50	-20.60	QP		
3		226.0994	31.85	-10.45	21.40	46.00	-24.60	QP		
4		291.0360	33.18	-7.88	25.30	46.00	-20.70	QP		
5		420.5803	36.94	-6.24	30.70	46.00	-15.30	QP		
6	*	517.2480	37.18	-5.78	31.40	46.00	-14.60	QP		



3.2.8 TEST RESULTS (1G-25GHZ)

GFSK,
Normal Voltage

Polar (H/V)	Frequency	Meter Reading	Factor	Emission Level	Limits	Margin	Detector Type
	(MHz)	(dBuV)	(dB)	(dBuV/m)	(dBuV/m)	(dB)	
Low Channel (2402 MHz)							
Vertical	2491.777	59.75	-11.65	48.1	74	25.90	Pk
Horizontal	2498.247	56.65	-12.73	43.92	74	30.08	Pk
Vertical	4804.156	66.75	-13.60	53.15	74	20.85	Pk
Horizontal	4804.156	56.75	-9.23	47.52	74	26.48	Pk
Vertical	1485.838	60.45	-17.1	43.35	74	30.65	Pk
Vertical	1636.784	60.14	-16.06	44.08	74	29.92	Pk
Vertical	2095.928	58.95	-11.88	47.07	74	26.93	Pk
Horizontal	1074.301	60.68	-19.69	40.99	74	33.01	Pk
Horizontal	1483.178	59.67	-17.09	42.58	74	31.42	Pk
Horizontal	1895.832	56.69	-14.25	42.44	74	31.56	Pk
Mid Channel (2441 MHz)							
Vertical	2474.777	56.37	-11.65	44.72	74	29.28	Pk
Horizontal	2474.144	57.06	-9.37	47.69	74	26.31	Pk
Vertical	4882.539	56.44	-6.15	50.29	74	23.71	Pk
Horizontal	4882.539	56.44	-6.83	49.61	74	24.39	Pk
Vertical	1433.535	63.43	-17.12	46.31	74	27.69	Pk
Vertical	1636.784	60.76	-16.06	44.7	74	29.3	Pk
Vertical	2284.166	54.5	-12.83	41.67	74	32.33	Pk
Horizontal	1280.515	60.16	-17.82	42.34	74	31.66	Pk
Horizontal	1636.784	58.99	-16.06	42.93	74	31.07	Pk
Horizontal	1892.438	59.11	-14.28	44.83	74	29.17	Pk
High Channel (2480 MHz)							
Vertical	2453.883	57.03	-12.91	44.12	74	29.88	Pk
Horizontal	2453.839	57.03	-11.59	45.44	74	28.56	Pk
Vertical	4960.256	53.54	-9.22	44.32	74	29.68	Pk
Horizontal	4960.478	63.54	-13.64	49.9	74	24.1	Pk
Vertical	1187.688	58.06	-18.27	39.79	74	34.21	Pk
Vertical	1636.784	56.87	-16.06	40.81	74	33.19	Pk
Vertical	2084.693	54.46	-11.99	42.47	74	31.53	Pk
Horizontal	1534.540	57.12	-16.94	40.18	74	33.82	Pk
Horizontal	1786.985	56.83	-15.04	41.79	74	32.21	Pk
Horizontal	1892.438	56.71	-14.28	42.43	74	31.57	Pk



π/4-DQPSK

Normal Voltage

Polar (H/V)	Frequency	Meter Reading	Factor	Emission Level	Limits	Margin	Detector Type
	(MHz)	(dBuV)	(dB)	(dBuV/m)	(dBuV/m)	(dB)	
operation frequency:2402							
V	4804.60	55.34	-13.64	58.98	74	-15.02	Pk
V	4804.60	43.27	-13.64	46.91	54	-7.09	AV
H	4804.36	50.84	-13.64	54.48	74	-19.52	Pk
H	4804.36	41.37	-13.64	45.01	54	-8.99	AV
operation frequency:2441							
V	4882.85	57.72	-13.68	61.40	74	-12.60	Pk
V	4882.85	43.77	-13.68	47.45	54	-6.55	AV
H	4882.69	54.13	-13.68	57.81	74	-16.19	Pk
H	4882.69	42.96	-13.68	46.64	54	-7.36	AV
operation frequency:2480							
V	4960.34	57.47	-13.59	61.06	74	-12.94	pk
V	4960.34	43.05	-13.59	46.64	54	-7.36	AV
H	4960.99	54.81	-13.59	58.40	74	-15.60	pk
H	4960.99	40.38	-13.59	43.97	54	-10.03	pk
Remark:							
Absolute Level= Reading Level+ Factor, Margin= Absolute Level - Limit							

8-DPSK

Normal Voltage

Polar (H/V)	Frequency	Meter Reading	Factor	Emission Level	Limits	Margin	Detector Type
	(MHz)	(dBuV)	(dB)	(dBuV/m)	(dBuV/m)	(dB)	
operation frequency:2402							
V	4804.92	54.60	-13.64	58.24	74	-15.76	Pk
H	4804.03	54.13	-13.64	57.77	74	-16.23	Pk
operation frequency:2441							
V	4882.54	56.46	-13.68	60.14	74	-13.86	Pk
H	4882.28	52.69	-13.68	56.37	74	-17.63	Pk
operation frequency:2480							
V	4882.38	53.13	-13.59	57.06	74	-16.94	pk
H	4882.50	54.12	-13.59	58.58	74	-15.42	pk
Remark:							
Absolute Level= Reading Level+ Factor, Margin= Absolute Level - Limit							

Note: The PK value is less than the AV value, AV value is not required
Factor added by measurement software automatically.



3.3 BAND EDGE(RADIATED)

Frequency (MHz)	Meter Reading (dB μ V)	Factor (dB)	Emission Level (dB μ V/m)	Limits (dB μ V/m)	Margin (dB)	Detector Type	Comment
GFSK							
2390	52.42	-12.78	39.64	74	-34.36	peak	Vertical
2390	51.35	-12.78	38.57	74	-35.43	peak	Horizontal
2483.5	52.64	-13.78	38.86	74	-35.14	peak	Vertical
2483.5	54.49	-13.78	40.71	74	-33.29	peak	Horizontal
$\pi/4$-DQPSK							
2390	50.95	-13.06	37.89	74	-36.11	peak	Vertical
2390	52.83	-13.06	39.77	74	-34.23	peak	Horizontal
2483.5	51.22	-12.78	38.44	74	-35.56	peak	Vertical
2483.5	52.19	-12.78	39.41	74	-34.59	peak	Horizontal
8-DPSK							
2390	53.11	-13.06	40.05	74	-33.95	peak	Vertical
2390	54.24	-13.06	41.18	74	-32.82	peak	Horizontal
2483.5	52.56	-12.78	39.78	74	-34.22	peak	Vertical
2483.5	52.58	-12.78	39.80	74	-34.20	peak	Horizontal

NOTE: The PK value is less than the AV value, AV value is not required.



BAND EDGE(RADIATED)(HOPPING MODE)

Frequency (MHz)	Meter Reading (dBμV)	Factor (dB)	Emission Level (dBμV/m)	Limits (dBμV/m)	Margin (dB)	Detector Type	Comment
GFSK							
2390	54.06	-12.78	41.28	74	-32.72	peak	Vertical
2390	51.73	-12.78	38.95	74	-35.05	peak	Horizontal
2483.5	51.93	-15.78	39.15	74	-34.85	peak	Vertical
2483.5	51.43	-15.78	38.65	74	-35.35	peak	Horizontal
π/4-DQPSK							
2390	51.50	-13.06	38.44	74	-35.56	peak	Vertical
2390	51.44	-13.06	38.38	74	-35.62	peak	Horizontal
2483.5	50.10	-12.78	37.32	74	-36.68	peak	Vertical
2483.5	54.33	-12.78	41.55	74	-32.45	peak	Horizontal
8-DPSK							
2390	52.43	-13.06	39.37	74	-34.63	peak	Vertical
2390	54.45	-13.06	41.39	74	-32.61	peak	Horizontal
2483.5	51.63	-12.78	38.85	74	-35.15	peak	Vertical
2483.5	50.82	-12.78	38.04	74	-35.96	peak	Horizontal

NOTE: The PK value is less than the AV value, AV value is not required.



4. 20DB OCCUPY BANDWIDTH

4.1 APPLIED PROCEDURES / LIMIT

FCC Part15 (15.247) , Subpart C				
Section	Test Item	Limit	Frequency Range (MHz)	Result
15.247a(1)	20dB bandwidth	/	2400-2483.5	PASS

4.1.1 TEST PROCEDURE

- (1) The EUT was directly connected to the spectrum analyzer and antenna output port as show in the block diagram above.
- (2) Spectrum Setting:
Bandwidth: RBW=10 kHz, VBW=30 kHz, detector= Peak

4.1.2 DEVIATION FROM STANDARD

No deviation.

4.1.3 TEST SETUP



4.1.4 EUT OPERATION CONDITIONS

The EUT tested system was configured as the statements of 2.1 Unless otherwise a special operating condition is specified in the follows during the testing.



4.1.5 TEST RESULTS

EUT :	ACIL H1	Model Name :	H1
Temperature :	25 °C	Relative Humidity :	60%
Pressure :	1015 hPa	Test Voltage :	DC 5V from USB Port
Test Mode :	GFSK Mode /CH00, CH39, CH78		

Frequency	20dB Bandwidth (MHz)	Limit	Result
2402 MHz	1.096	/	PASS
2441 MHz	1.100	/	PASS
2480 MHz	1.093	/	PASS

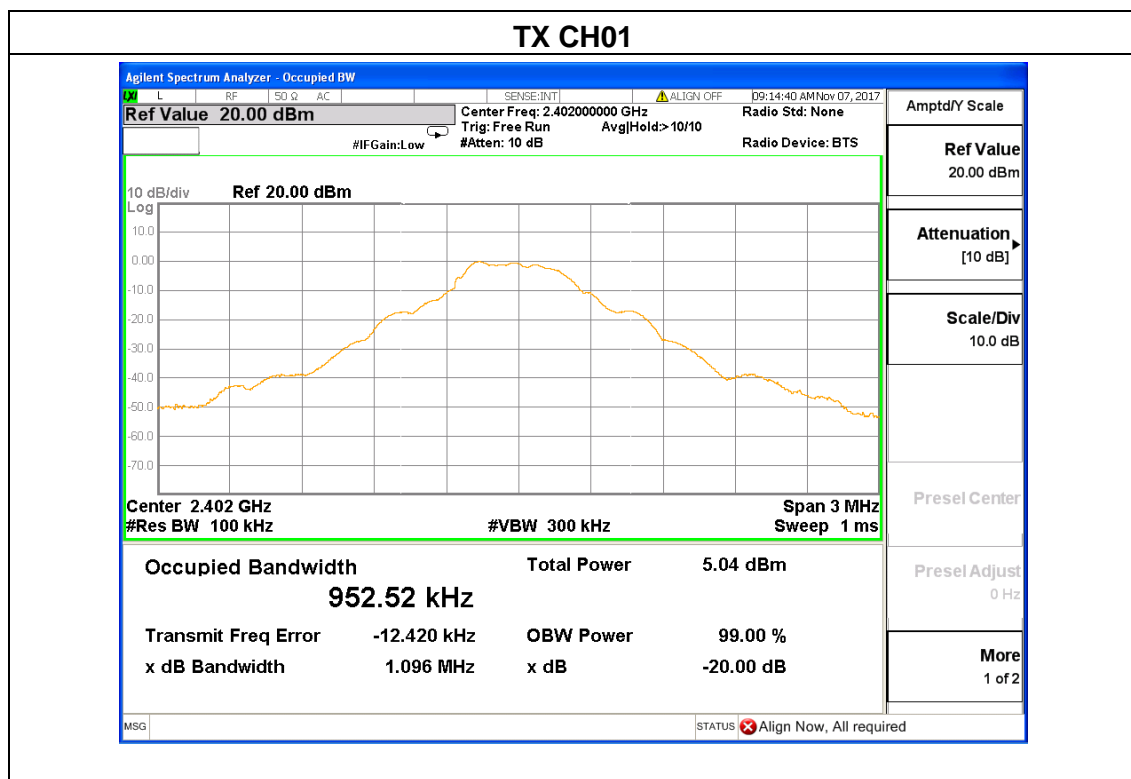

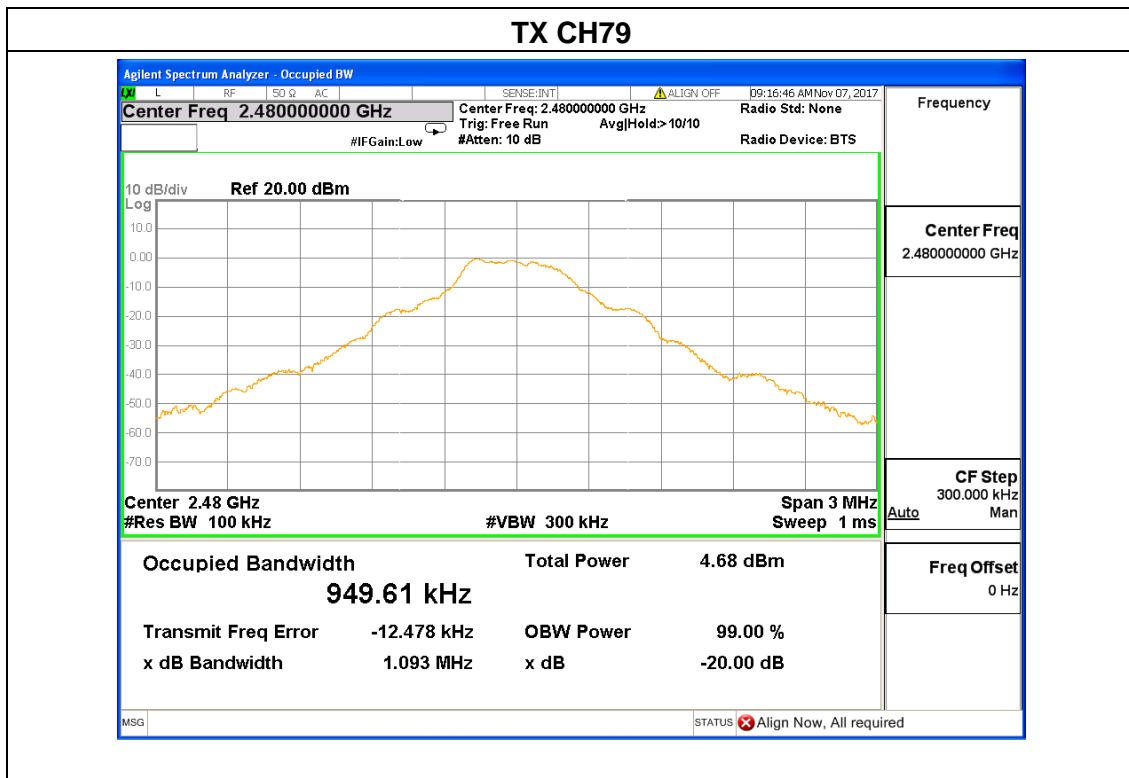
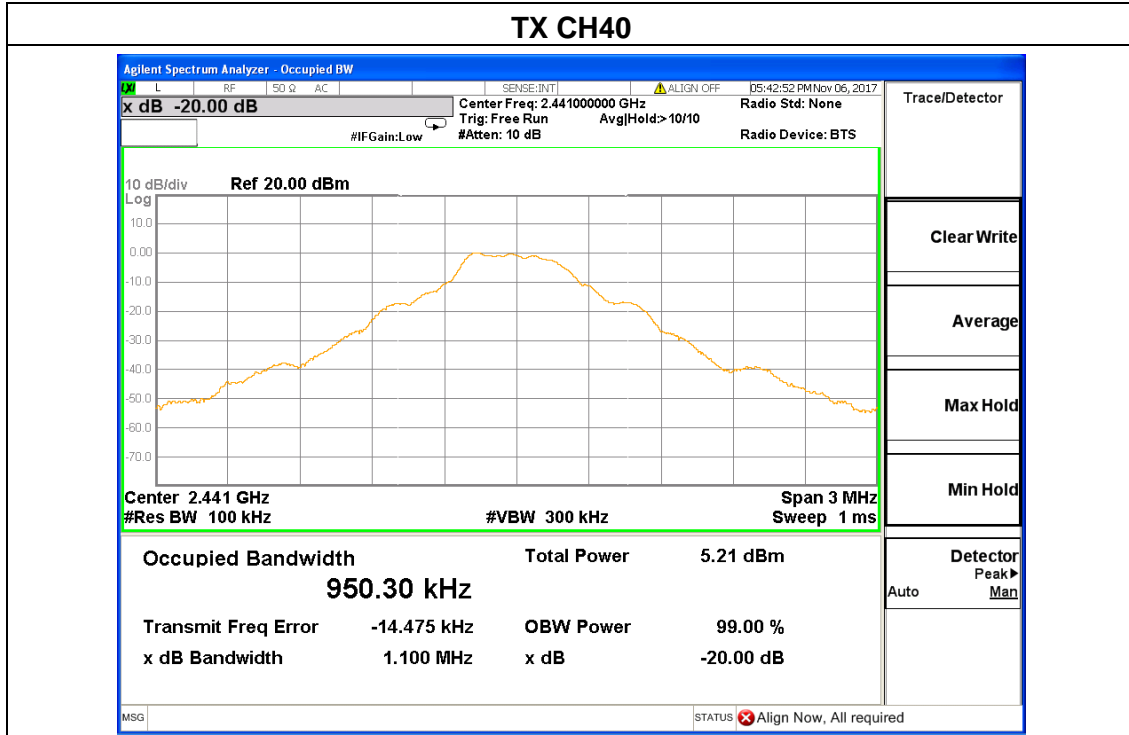



EUT :	ACIL H1	Model Name :	H1
Temperature :	25 °C	Relative Humidity :	60%
Pressure :	1015 hPa	Test Voltage :	DC 5V from USB Port
Test Mode :	π/4-DQPSK, Mode /CH00, CH39, CH78		

Frequency	20dB Bandwidth (MHz)	Limit	Result
2402 MHz	1.276	/	PASS
2441 MHz	1.301	/	PASS
2480 MHz	1.286	/	PASS

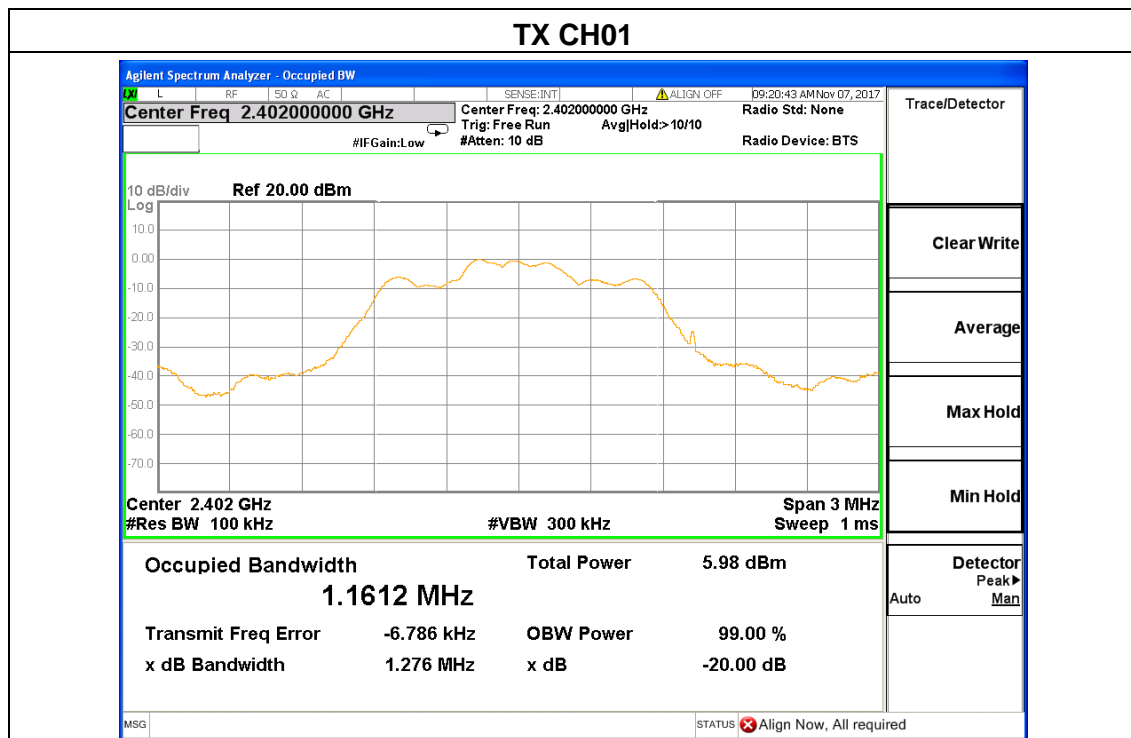

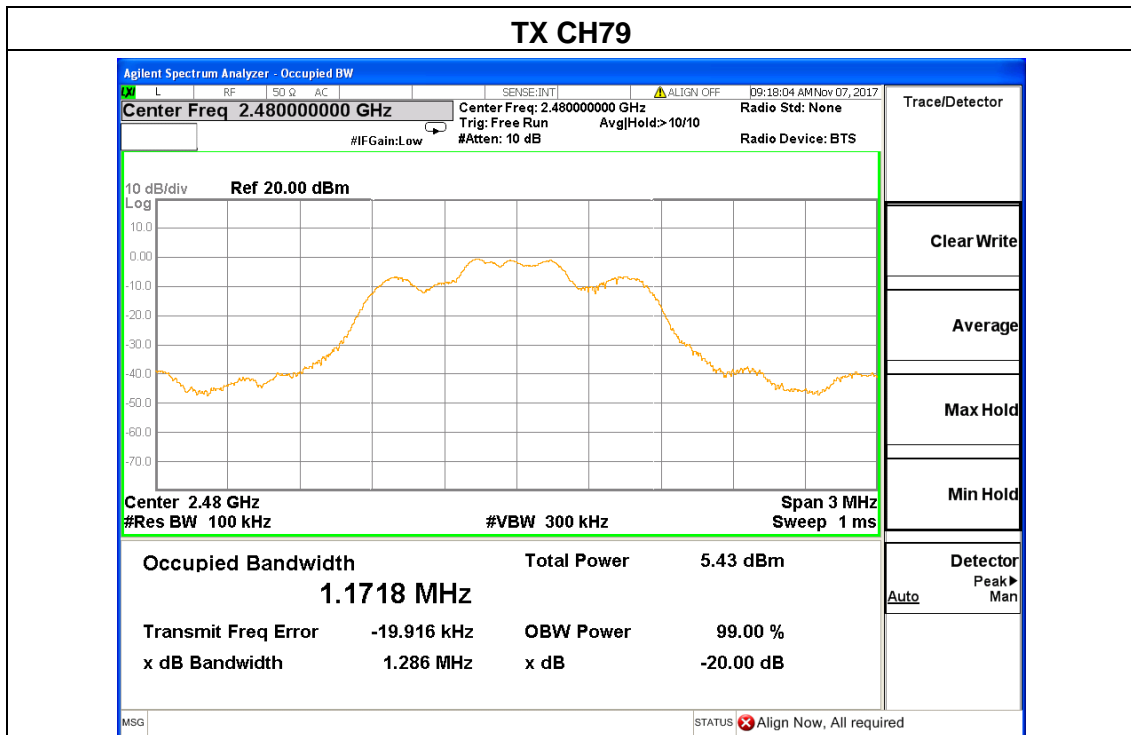
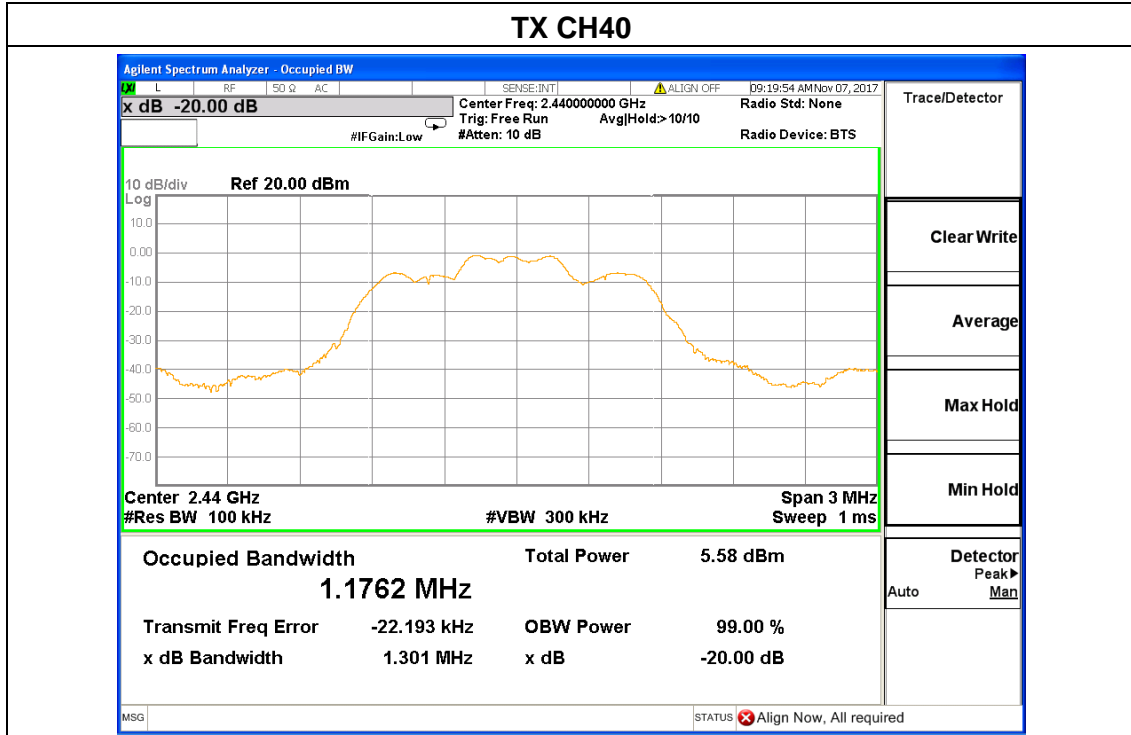



EUT :	ACIL H1	Model Name :	H1
Temperature :	25 °C	Relative Humidity :	60%
Pressure :	1015 hPa	Test Voltage :	DC 5V from USB Port
Test Mode :	8-DPSK Mode /CH00, CH39, CH78		

Frequency	20dB Bandwidth (MHz)	Limit	Result
2402 MHz	1.319	/	PASS
2441 MHz	1.272	/	PASS
2480 MHz	1.273	/	PASS

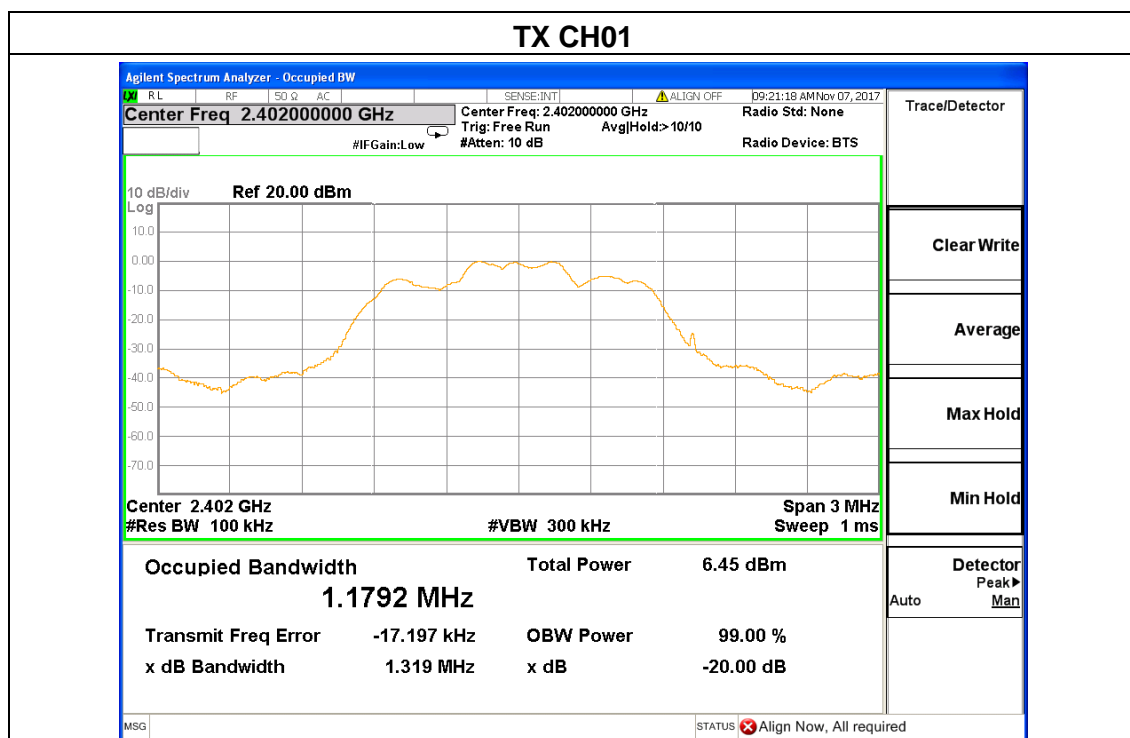

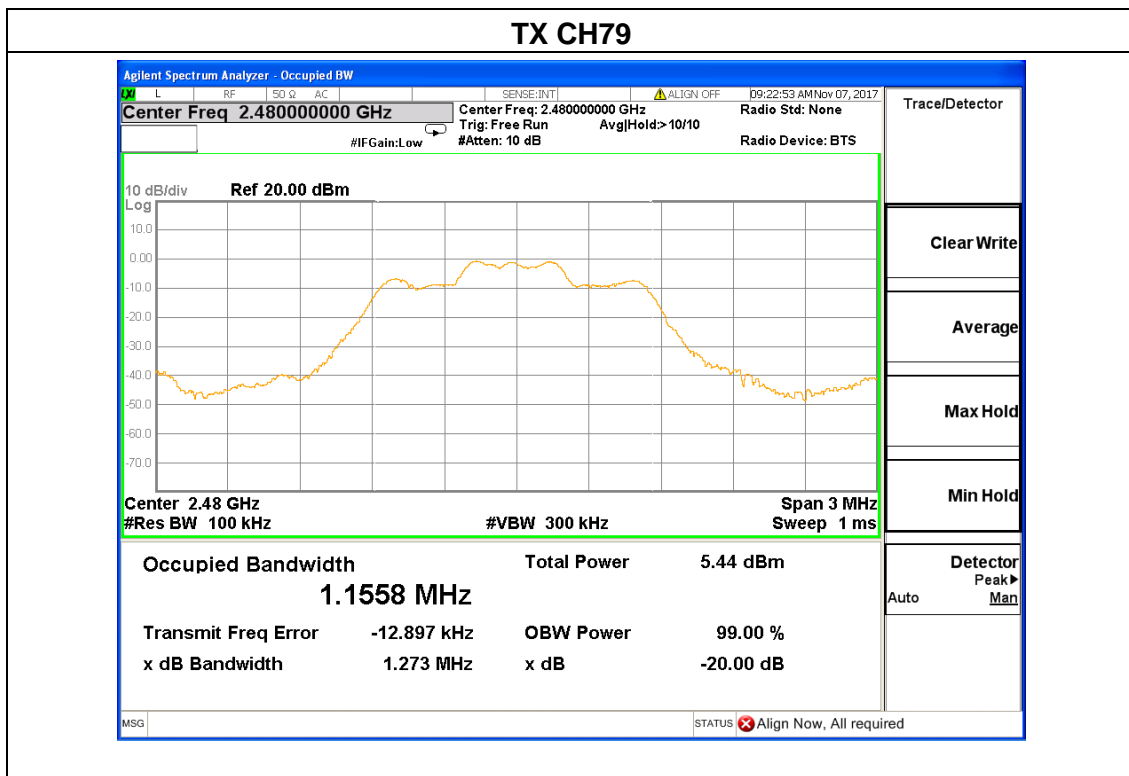
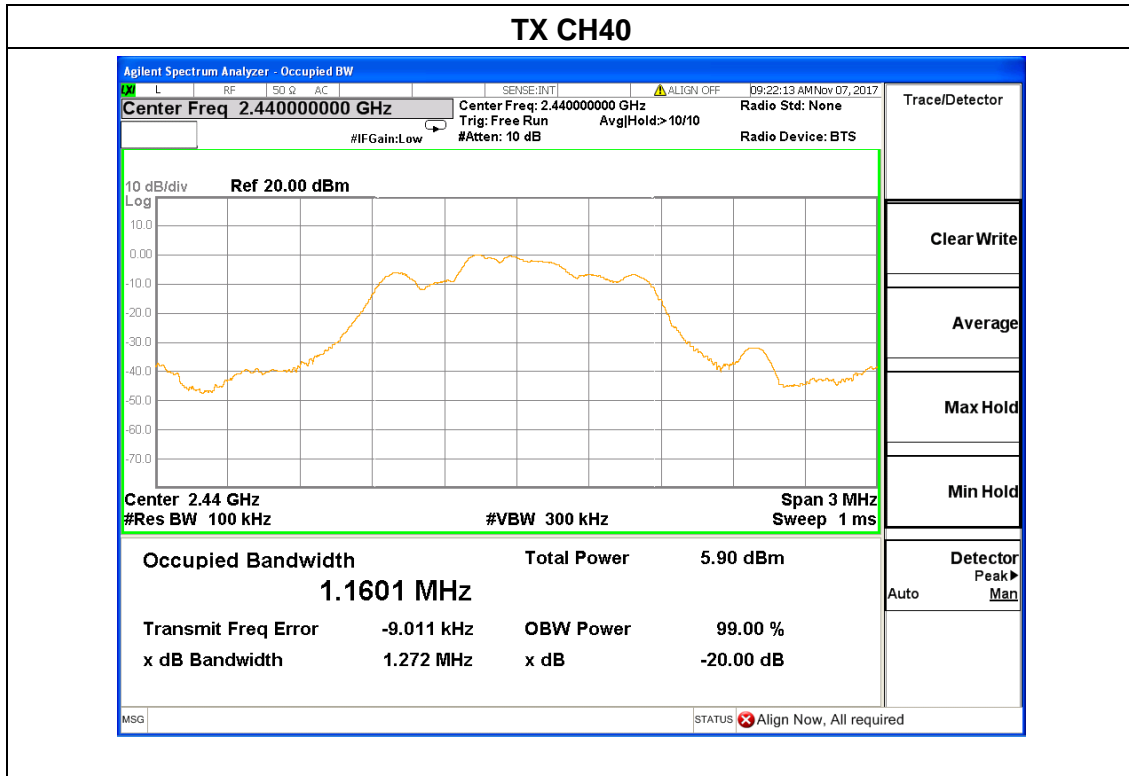



5. CARRIER FREQUENCY SEPARATION TEST

5.1 APPLIED PROCEDURES / LIMIT

FCC Part15 (15.247) , Subpart C				
Section	Test Item	Limit	Frequency Range (MHz)	Result
15.247(a)(1)	Channel Separation	>25KHz or >two-thirds of the 20 dB bandwidth (Which is greater)	2400-2483.5	PASS

5.1.1 TEST PROCEDURE

- (1) The EUT was directly connected to the spectrum analyzer and antenna output port as show in the block diagram above.
- (2) Spectrum Setting:
RBW=100 kHz, VBW=300 kHz, detector= Peak, Sweep Time =auto.
- (3) The EUT was set to the Hopping Mode for Channel Separation Test and continuously transmitting for the Test.

5.1.2 DEVIATION FROM STANDARD

No deviation.

5.1.3 TEST SETUP

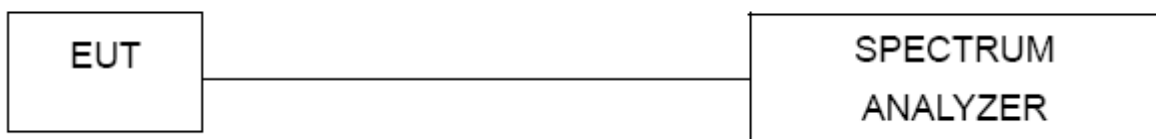

5.1.4 EUT OPERATION CONDITIONS

The EUT tested system was configured as the statements of 2.4 Unless otherwise a special operating condition is specified in the follows during the testing.



5.1.5 TEST RESULTS

EUT :	ACIL H1	Model Name :	H1
Temperature :	25 °C	Relative Humidity :	60%
Pressure :	1012 hPa	Test Voltage :	DC 5V from USB Port
Test Mode :	GFSK Mode /CH00, CH39, CH78		

Mode	Channel	Frequency (MHz)	Test Result (KHz)	Limit (kHz)	Result
GFSK	Middle	2441	996	731	Pass
$\pi/4$ -DQPSK	Middle	2441	1008	733	Pass
8DPSK	Middle	2441	1002	728	Pass

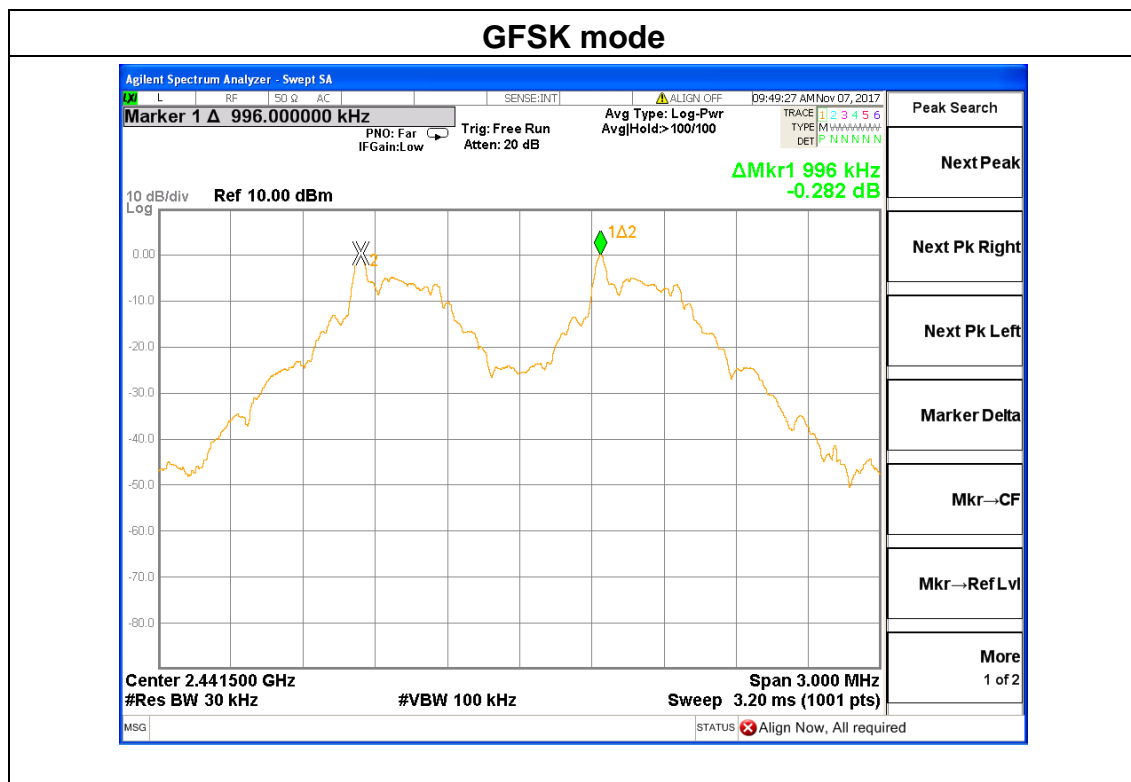

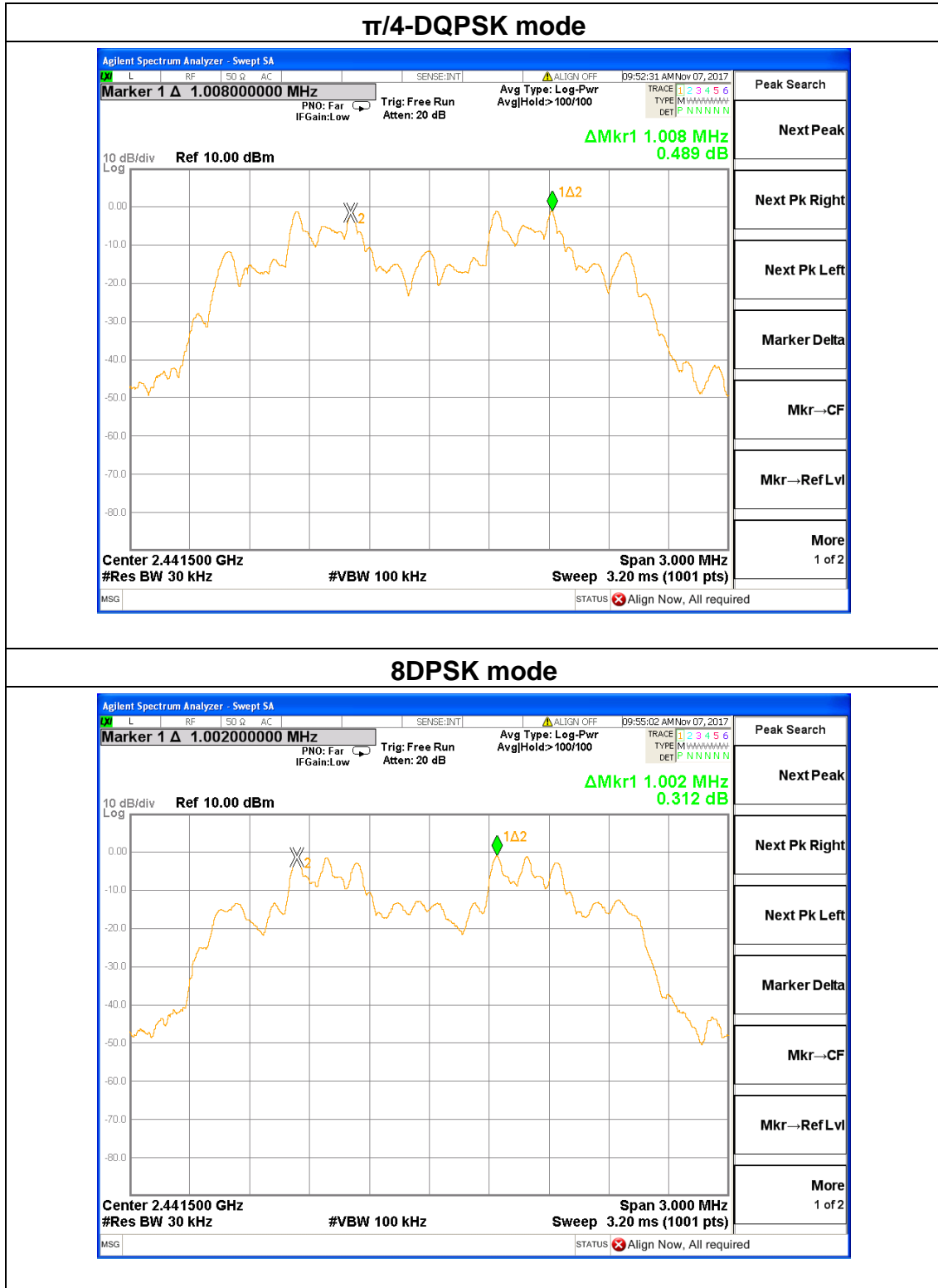



6. NUMBER OF HOPPING CHANNEL

6.1 APPLIED PROCEDURES / LIMIT

FCC Part15 (15.247) , Subpart C				
Section	Test Item	Limit	Frequency Range (MHz)	Result
15.247(a)(a)	Number of Hopping Channel	>15 channels	2400-2483.5	PASS

6.1.1 TEST PROCEDURE

- (1) The EUT was directly connected to the spectrum analyzer and antenna output port as show in the block diagram above.
- (2) Spectrum Setting: RBW=100 kHz, VBW=300 kHz, Detector=Peak, Sweep time= Auto.
- (3) The EUT was set to the Hopping Mode for Channel Separation Test and continuously transmitting for the Test.

6.1.2 DEVIATION FROM STANDARD

No deviation.

6.1.3 TEST SETUP

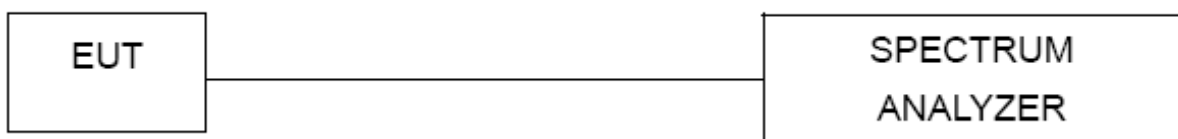

6.1.4 EUT OPERATION CONDITIONS

The EUT tested system was configured as the statements of 2.4 Unless otherwise a special operating condition is specified in the follows during the testing.

6.1.5 TEST RESULTS

EUT :	ACIL H1	Model Name :	H1
Temperature :	25 °C	Relative Humidity :	60%
Pressure :	1012 hPa	Test Voltage :	DC 5V from USB Port
Test Mode :	GFSK, π/4-DQPSK, 8-DPSK Mode / CH00, CH39, CH78		



III

Mode	Quantity of Hopping Channel	Limit	Judgment
GFSK, $\pi/4$ -DQPSK, 8DPSK	79	>15	PASS

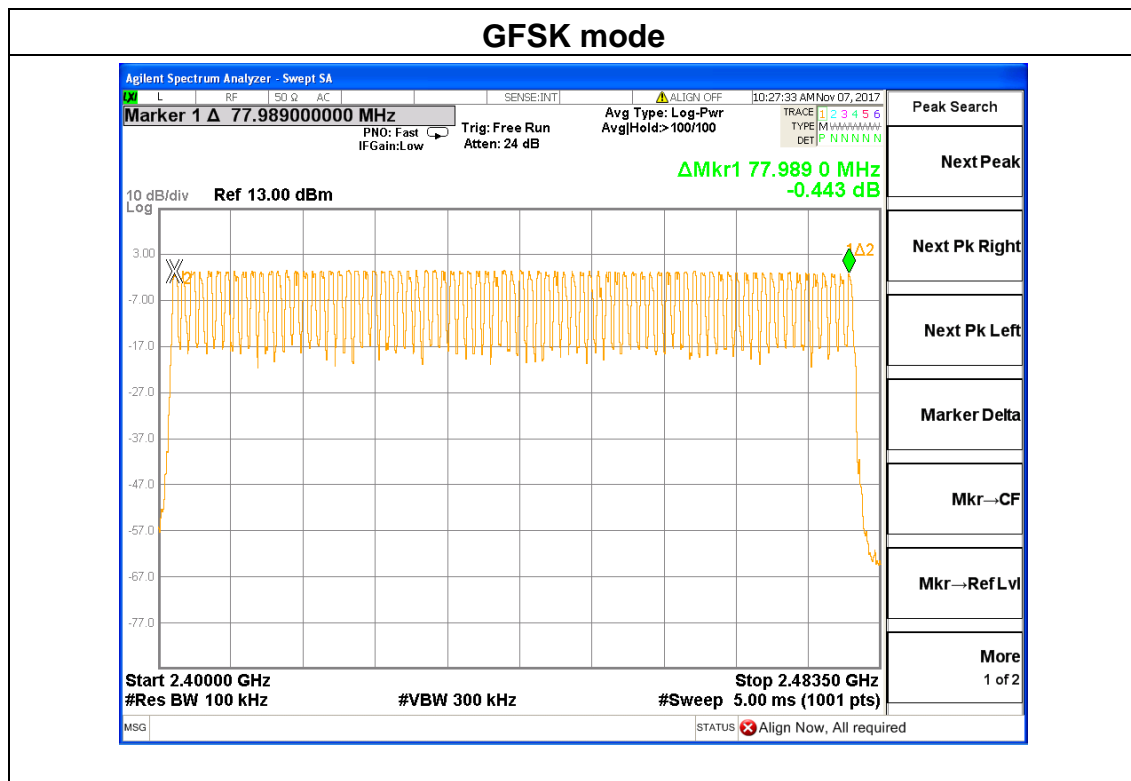



$\pi/4$ -DQPSK mode

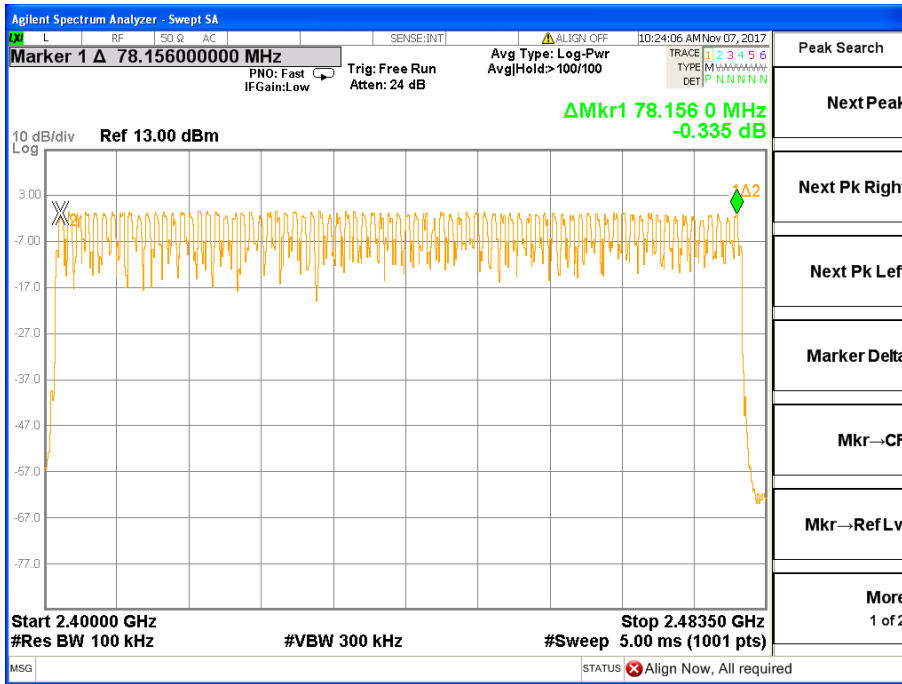

8DPSK mode

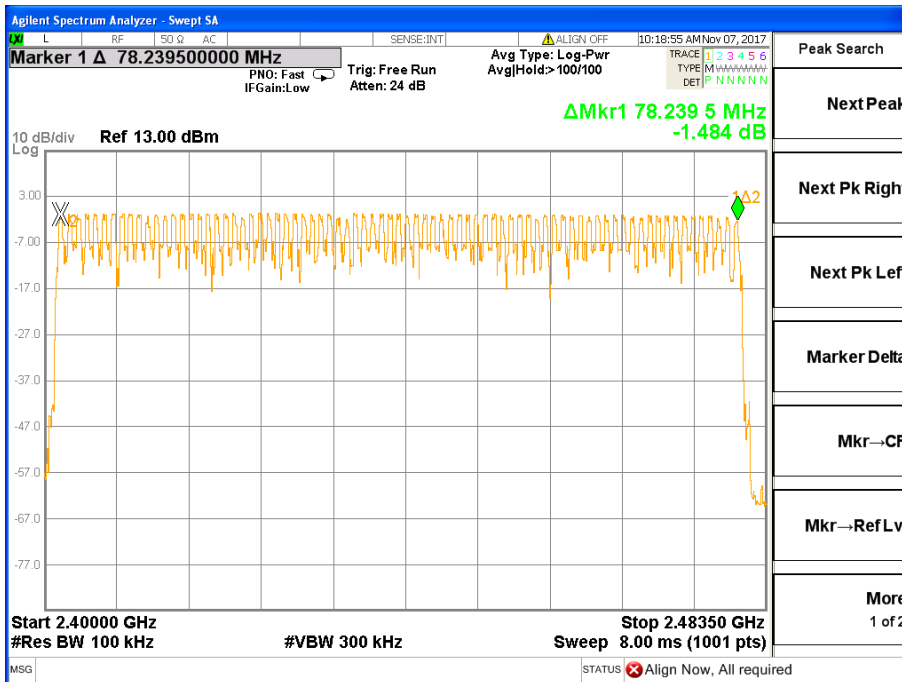



7. DWELL TIME

7.1 APPLIED PROCEDURES / LIMIT

FCC Part15 (15.247) , Subpart C				
Section	Test Item	Limit	Frequency Range (MHz)	Result
15.247(a)(a)	Dwell time	0.4 sec	2400-2483.5	PASS

7.1.1 TEST PROCEDURE

- (1) The EUT was directly connected to the spectrum analyzer and antenna output port as show in the block diagram above.
- (2) Spectrum Setting: RBW=1MHz, VBW=1MHz, Span=0Hz, Detector=Peak
- (3) Use video trigger with the trigger level set to enable triggering only on full pulses.
- (4) Sweep Time is more than once pulse time.
- (5) Set the center frequency on any frequency would be measure and set the frequency span to zero span.
- (6) Measure the maximum time duration of one single pulse.
- (7) Set the EUT for packet transmitting.
- (8) Measure the maximum time duration of one single pulse.
- (9) The EUT was set to the Hopping Mode for Dwell Time Test

7.1.2 DEVIATION FROM STANDARD

No deviation.

7.1.3 TEST SETUP



7.1.4 EUT OPERATION CONDITIONS

The EUT tested system was configured as the statements of 2.4 Unless otherwise a special operating condition is specified in the follows during the testing.



7.1.5 TEST RESULTS

EUT :	ACIL H1	Model Name :	H1
Temperature :	25 °C	Relative Humidity :	60%
Pressure :	1012 hPa	Test Voltage :	DC 5V from USB Port
Test Mode :	GFSK, π/4-DQPSK, 8-DPSK Mode / CH00, CH39, CH78		

For GFSK, π/4-DQPSK and 8DPSK:

The test period: T= 0.4 Second/Channel x 79 Channel = 31.6 s

Mode	Data Packet	Frequency (MHz)	Pulse Duration (ms)	Dwell Time (ms)	Limit (s)	Conclusion
GFSK	DH1	2441	0.369	118.08	<0.4	PASS
	DH3	2441	1.612	257.92	<0.4	PASS
	DH5	2441	2.856	304.64	<0.4	PASS
π/4 DQPSK	2DH1	2441	0.376	120.32	<0.4	PASS
	2DH3	2441	1.616	258.56	<0.4	PASS
	2DH5	2441	2.864	305.49	<0.4	PASS
8- DQPSK	3DH1	2441	0.373	119.36	<0.4	PASS
	3DH3	2441	1.612	257.92	<0.4	PASS
	3DH5	2441	2.876	306.77	<0.4	PASS
Note: 1 A period time = 0.4 (s) * 79 = 31.6(s) 2 DH1 time slot = Pulse Duration * (1600/(2*79)) * A period time DH3 time slot = Pulse Duration * (1600/(4*79)) * A period time DH5 time slot = Pulse Duration * (1600/(6*79)) * A period time						

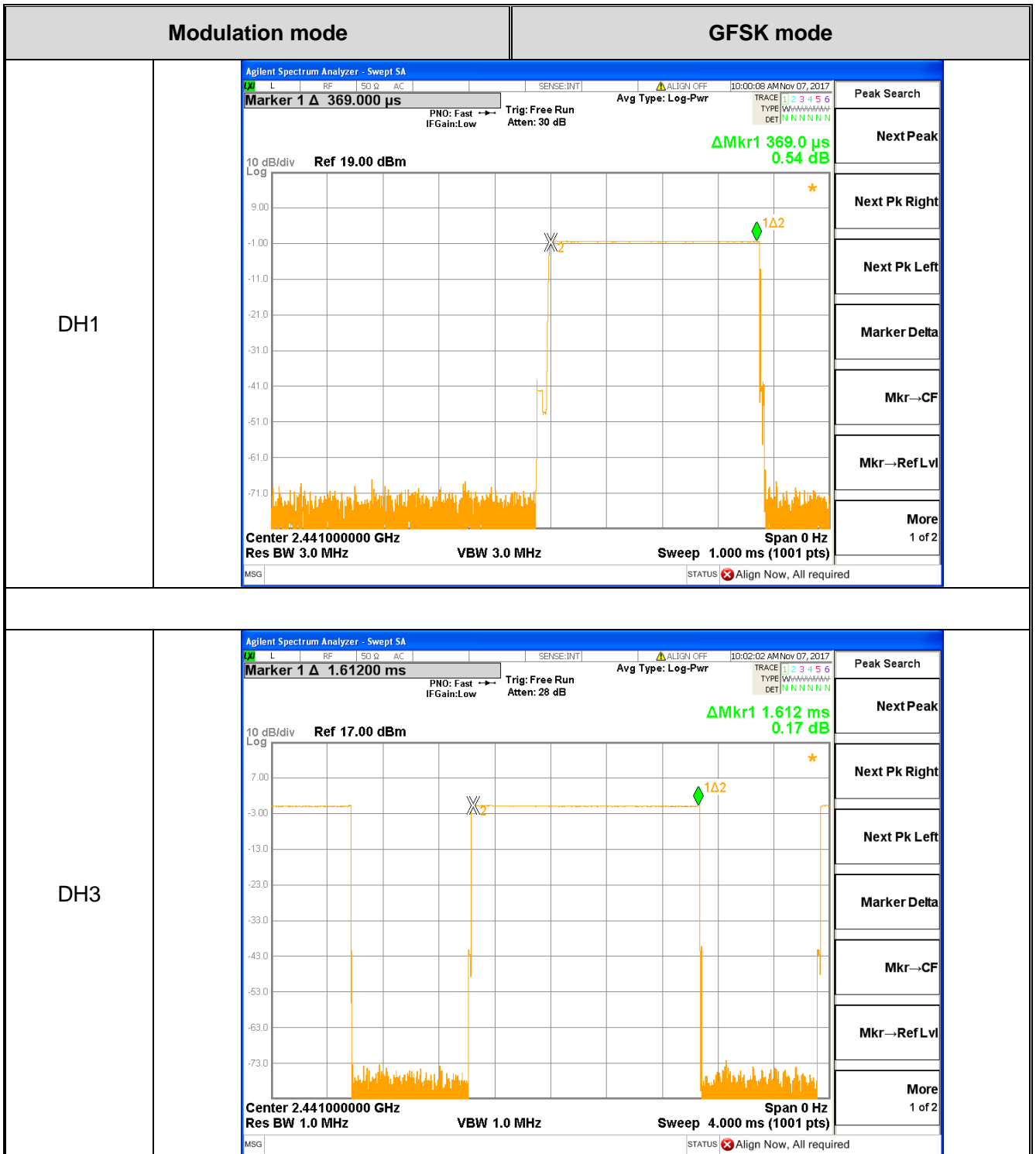

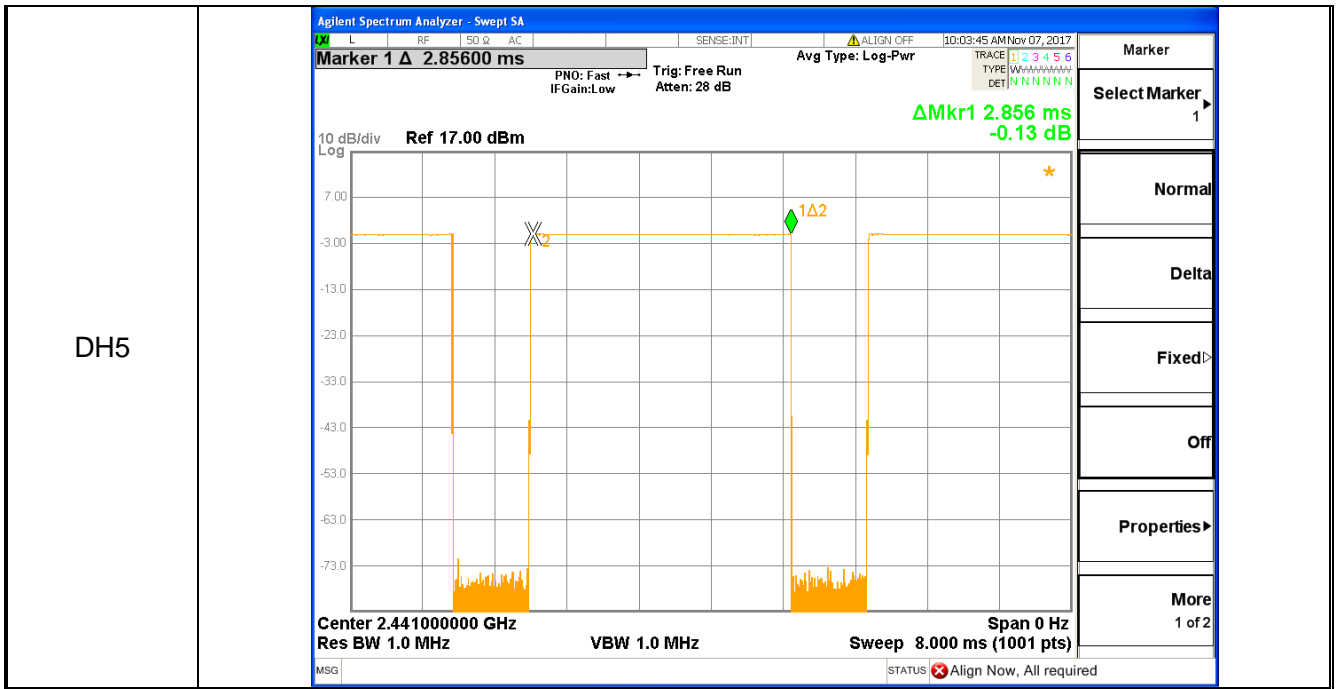



Modulation mode		$\pi/4$ -DQPSK	
2-DH1			<p>Agilent Spectrum Analyzer - Swept SA</p> <p>Marker 1 Δ 376.000 μs</p> <p>Ref 13.00 dBm</p> <p>Center 2.441000000 GHz</p> <p>Res BW 1.0 MHz</p> <p>VBW 1.0 MHz</p> <p>Sweep 2.000 ms (1001 pts)</p> <p>STATUS <input checked="" type="checkbox"/> Align Now, All required</p>
	<p>Peak Search</p> <p>Next Peak</p> <p>Next Pk Right</p> <p>Next Pk Left</p> <p>Marker Delta</p> <p>Mkr \rightarrow CF</p> <p>Mkr \rightarrow Ref Lvl</p> <p>More 1 of 2</p>		
2-DH3			<p>Agilent Spectrum Analyzer - Swept SA</p> <p>Marker 1 Δ 1.61600 ms</p> <p>Ref 18.00 dBm</p> <p>Center 2.441000000 GHz</p> <p>Res BW 3.0 MHz</p> <p>VBW 3.0 MHz</p> <p>Sweep 4.000 ms (1001 pts)</p> <p>STATUS <input checked="" type="checkbox"/> Align Now, All required</p>
	<p>Marker</p> <p>Select Marker 1</p> <p>Normal</p> <p>Delta</p> <p>Fixed \triangleright</p> <p>Off</p> <p>Properties \triangleright</p> <p>More 1 of 2</p>		

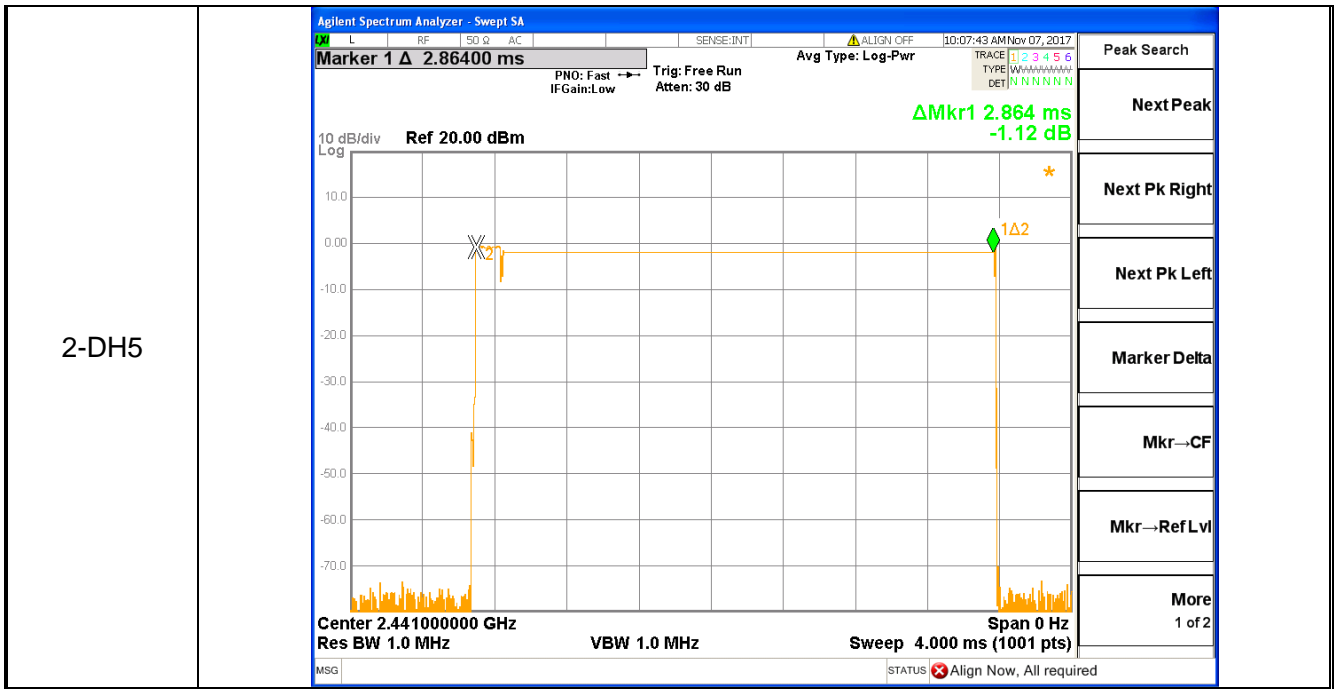

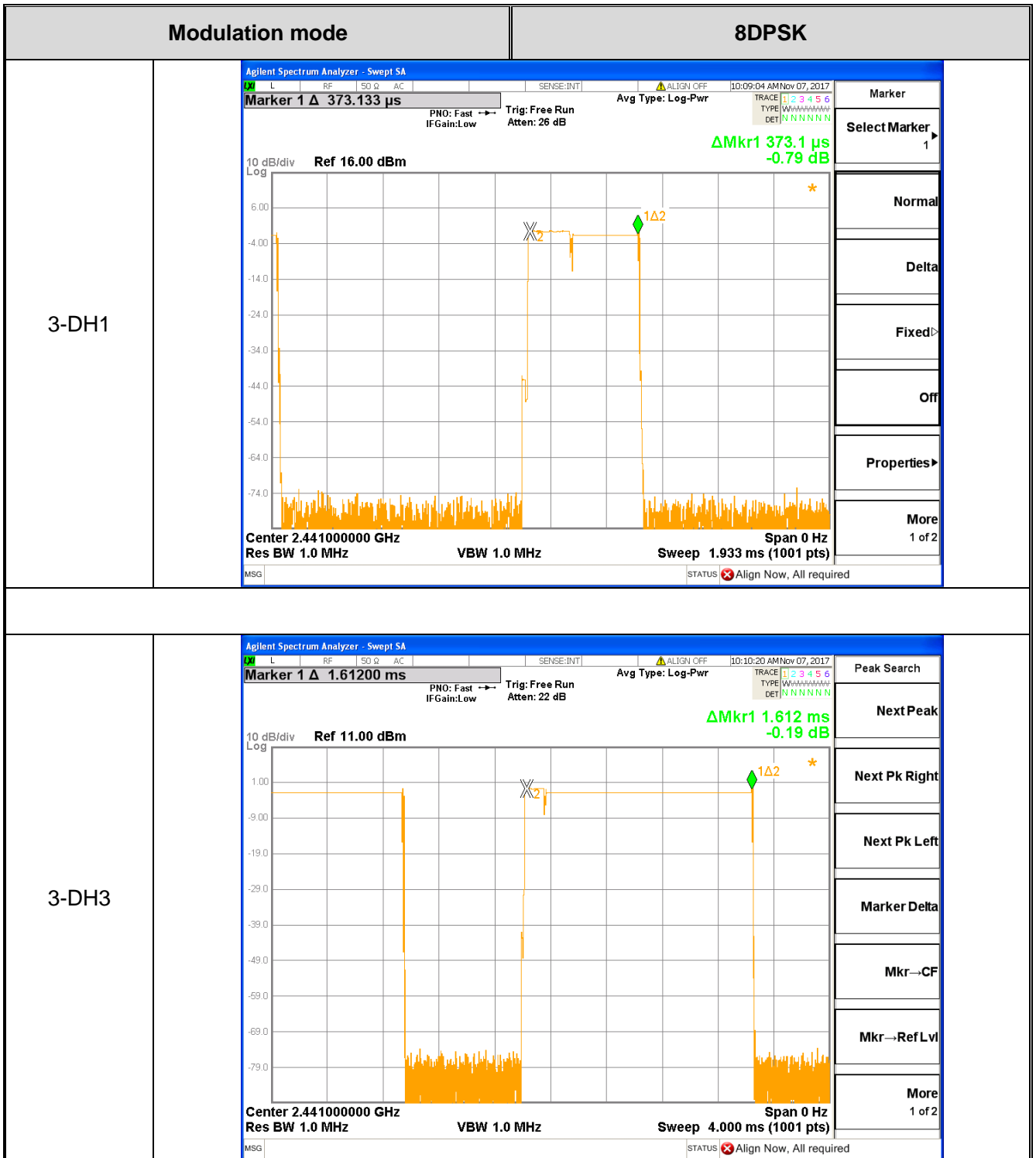

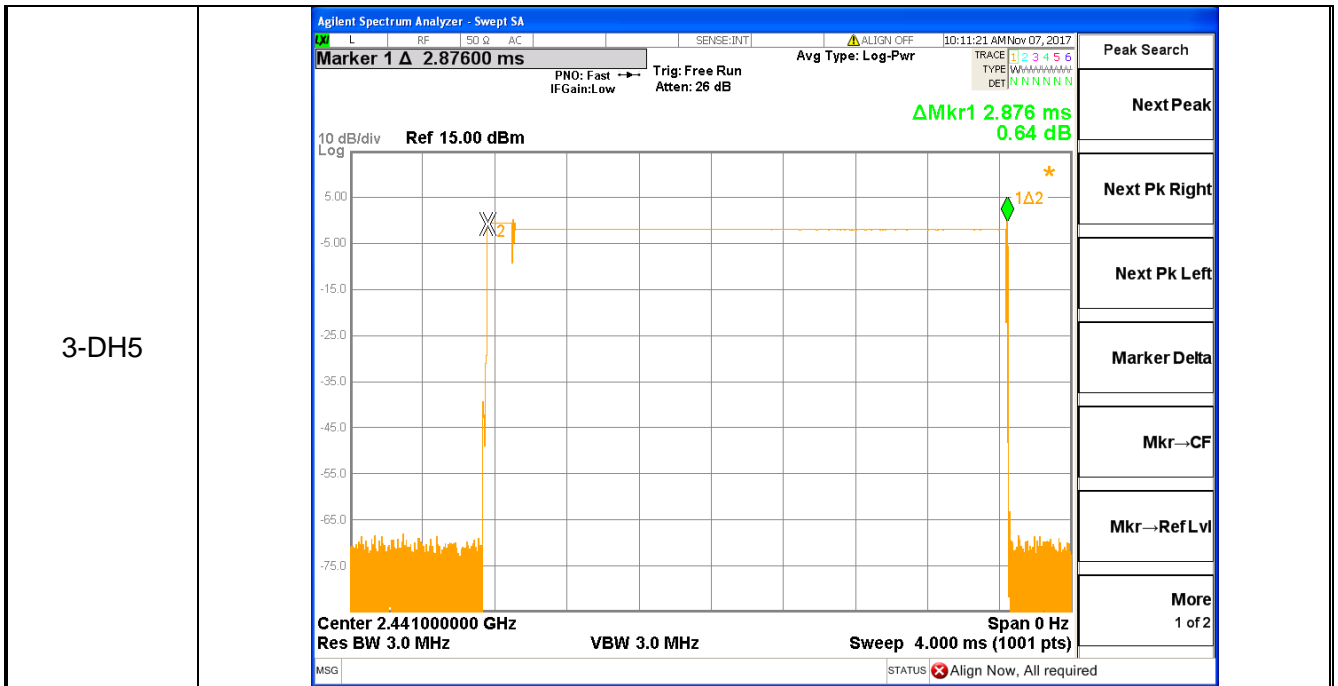



8. PEAK OUTPUT POWER TEST

8.1 APPLIED PROCEDURES / LIMIT

FCC Part15 (15.247) , Subpart C				
Section	Test Item	Limit	Frequency Range (MHz)	Result
15.247(b)(3)	Peak Output Power	Hopping Channels>75 Power<1W(30dBm) Other <125 mW(21dBm)	2400-2483.5	PASS

8.1.1 TEST PROCEDURE

- (1) The EUT was directly connected to the spectrum analyzer and antenna output port as show in the block diagram above.
- (2) Spectrum Setting:
RBW=1MHz, VBW=3MHz, Detector=Peak (If 20dB BW ≤ 1 MHz)
RBW=3MHz, VBW=10MHz, Detector=Peak (If 20dB BW > 1 MHz)
- (3) The EUT was set to continuously transmitting in the max power during the test.

8.1.2 DEVIATION FROM STANDARD

No deviation.

8.1.3 TEST SETUP



8.1.4 EUT OPERATION CONDITIONS

The EUT tested system was configured as the statements of 2.4 Unless otherwise a special operating condition is specified in the follows during the testing.



8.1.5 TEST RESULTS

EUT :	ACIL H1	Model Name :	H1
Temperature :	25 °C	Relative Humidity :	60%
Pressure :	1012 hPa	Test Voltage :	DC 5V from USB Port
Test Mode :	GFSK, $\pi/4$ -DQPSK, 8-DPSK Mode / CH00, CH39, CH78		

TX GFSK Mode			
Test Channel	Frequency	Maximum Conducted Output Power(PK)	LIMIT
	(MHz)	(dBm)	dBm
CH01	2402	1.321	30
CH40	2441	1.247	30
CH79	2480	1.157	30
TX $\pi/4$-DQPSK Mode			
CH01	2402	2.107	30
CH40	2441	2.010	30
CH79	2480	1.560	30
TX 8-DPSK Mode			
CH01	2402	2.096	30
CH40	2441	2.026	30
CH79	2480	1.586	30

///



GFSK 2402MHZ

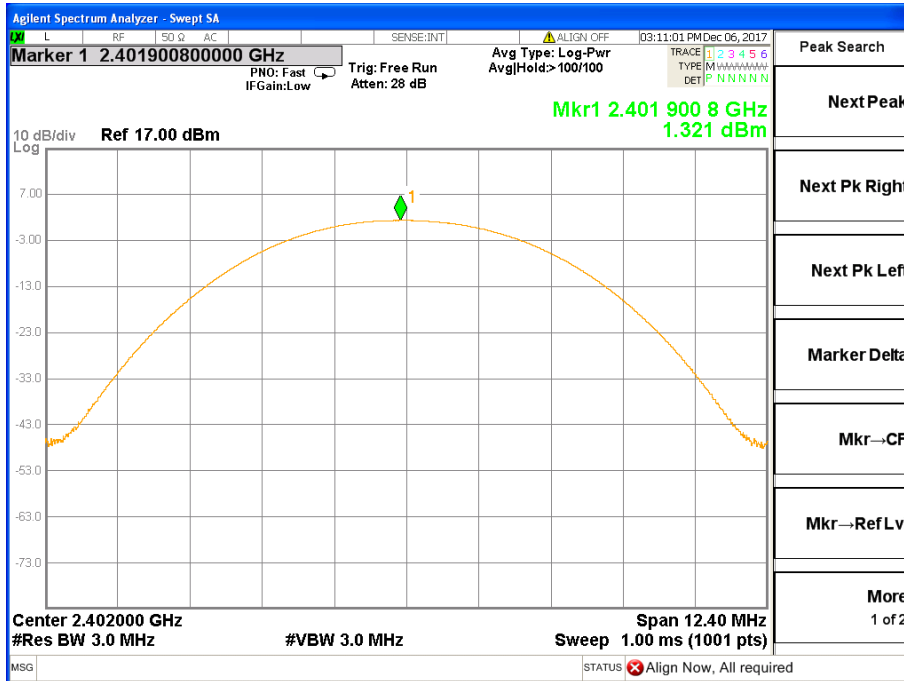



GFSK 2441MHz

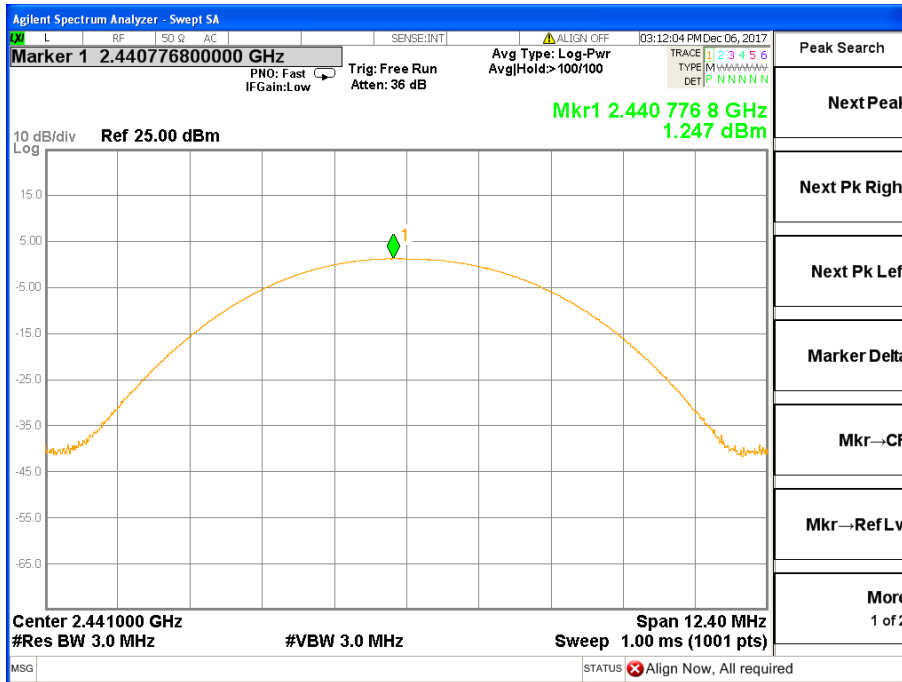

GFSK 2480MHz

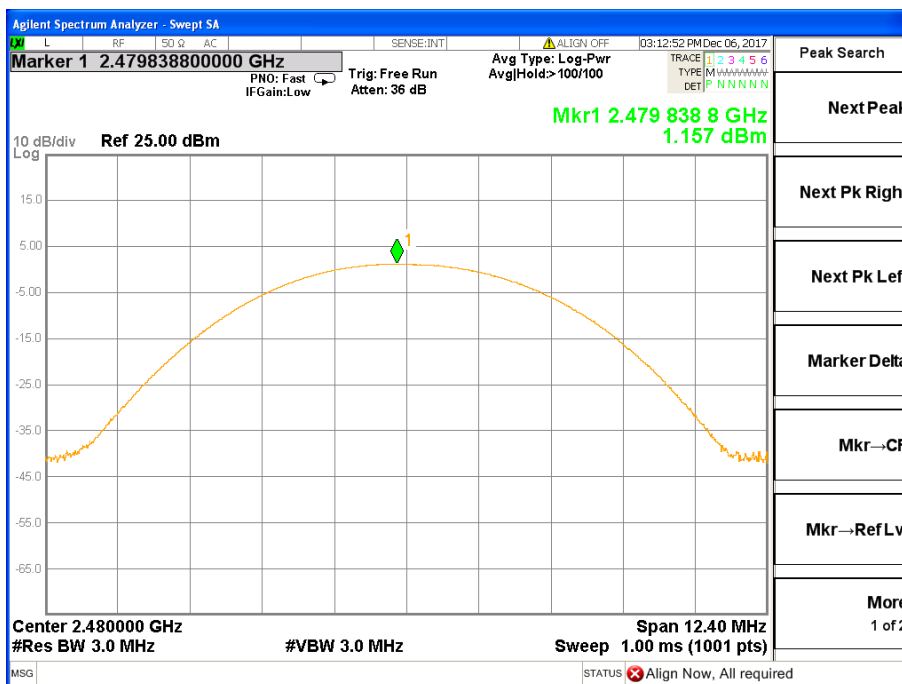



$\pi/4$ -DQPSK 2402

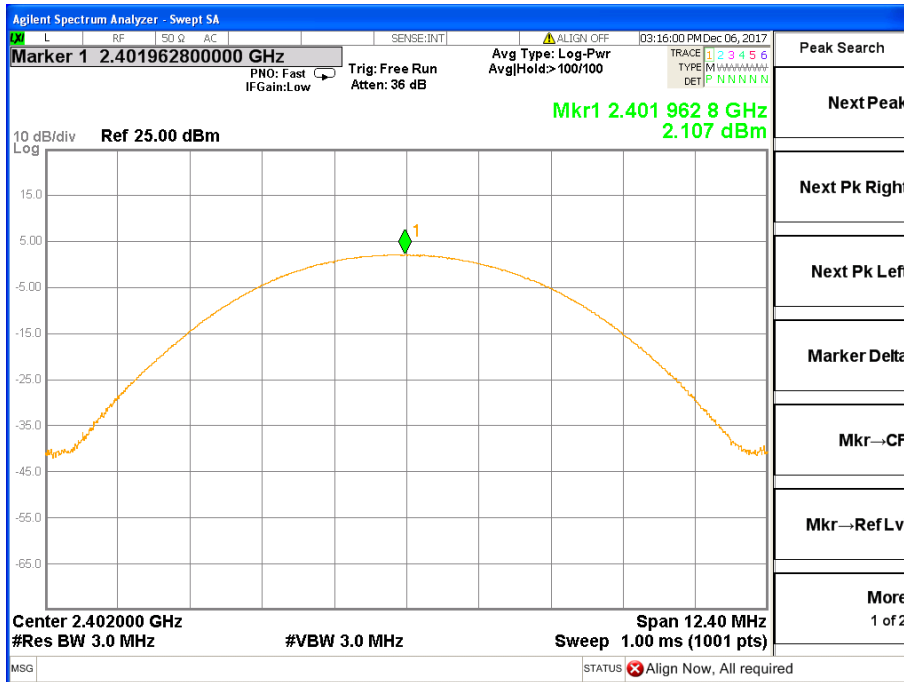

$\pi/4$ -DQPSK 2441

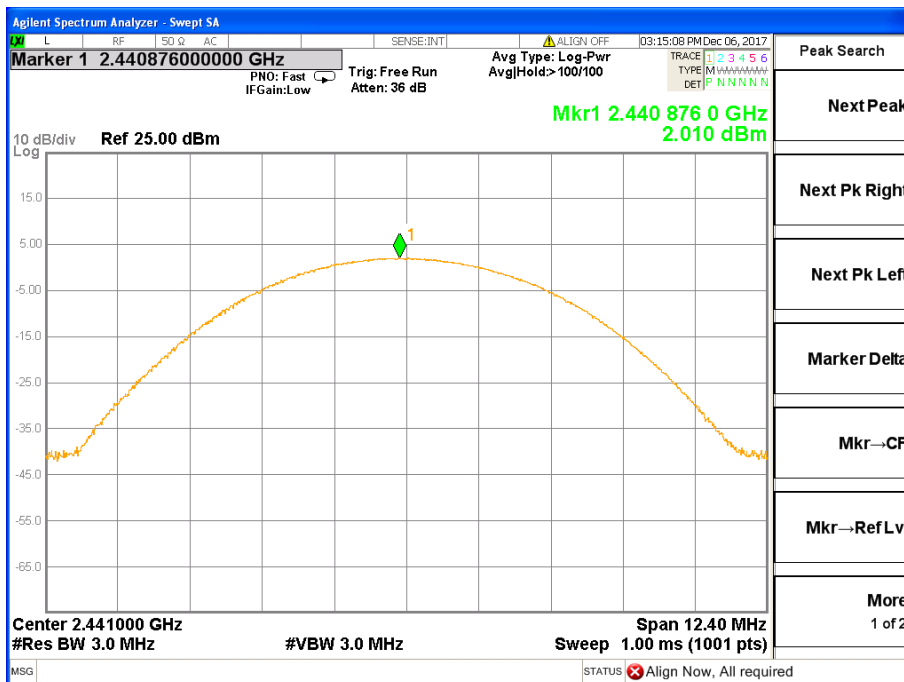



$\pi/4$ -DQPSK 2480

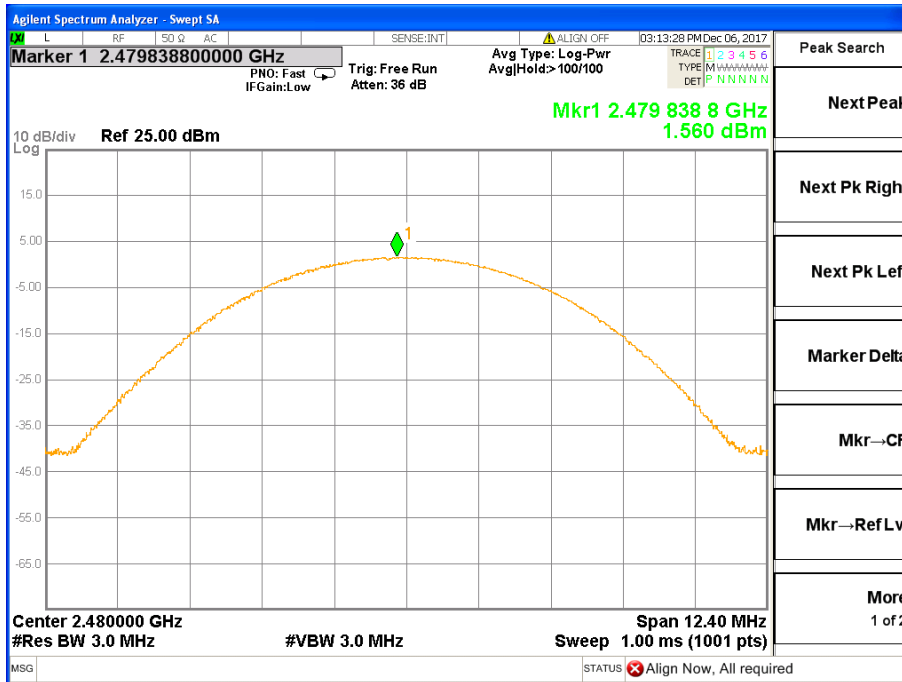

8-DPSK 2402MHz

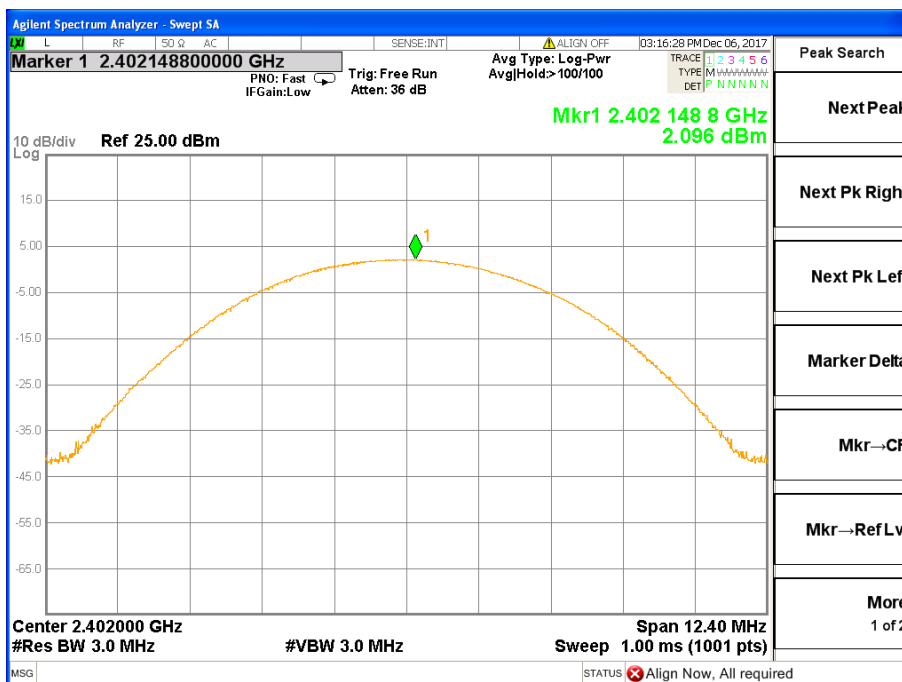



8-DPSK 2441MHz

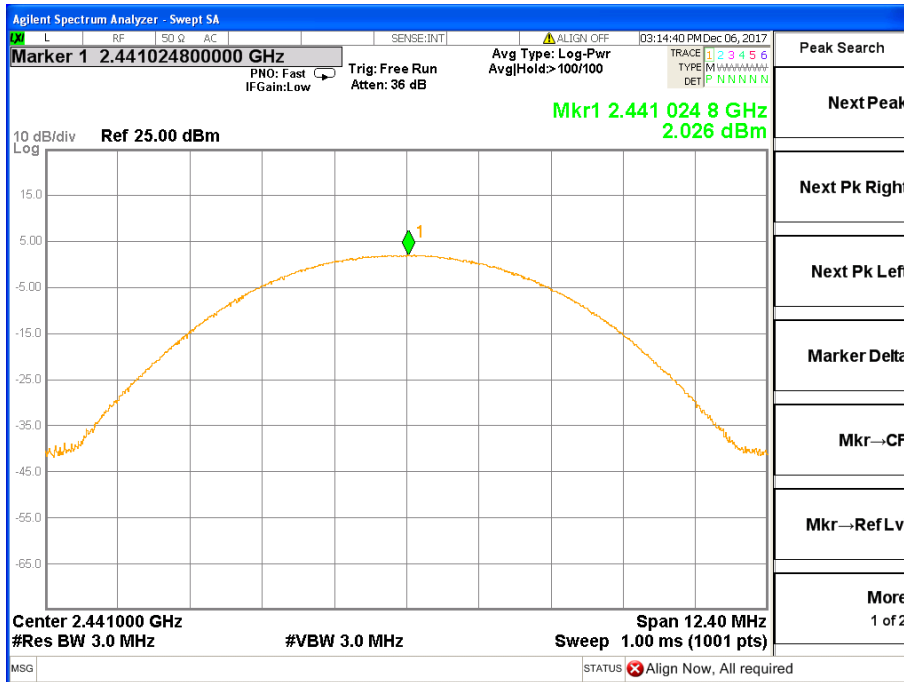

8-DPSK 2480MHz

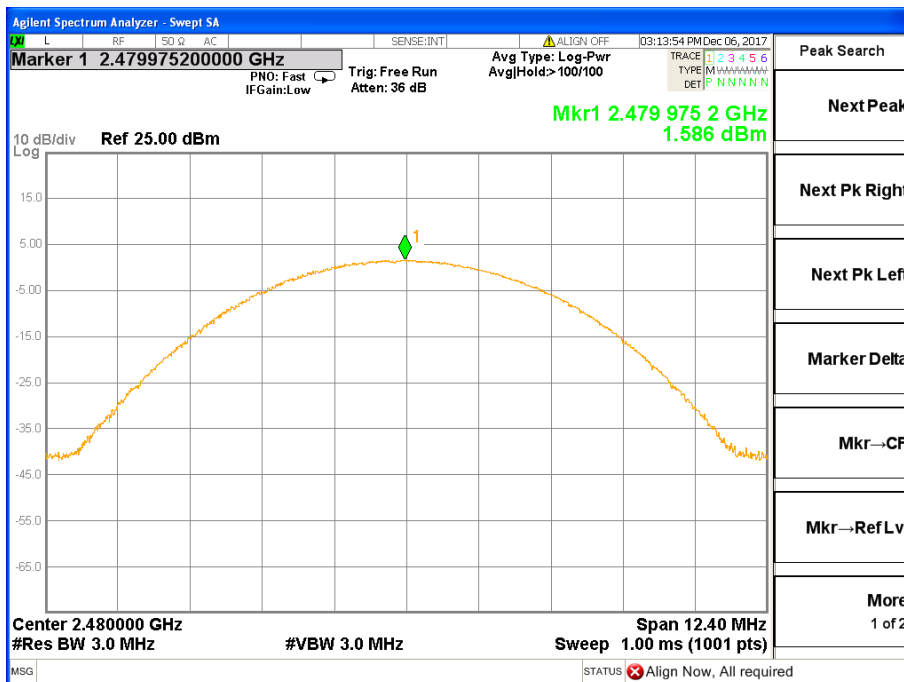



8.1.6. 100 kHz BANDWIDTH OF FREQUENCY BAND EDGE

APPLICABLE STANDARD

In any 100 kHz bandwidth outside the frequency band in which the spread spectrum or digitally modulated intentional radiator is operating, the radio frequency power that is produced by the intentional radiator shall be at least 20 dB below that in the 100 kHz bandwidth within the band that contains the highest level of the desired power, based on either an RF conducted or a radiated measurement, provided the transmitter demonstrates compliance with the peak conducted power limits. If the transmitter complies with the conducted power limits based on the use of RMS averaging over a time interval, as permitted under paragraph (b)(3) of this section, the attenuation required under this paragraph shall be 30 dB instead of 20 dB. Attenuation below the general limits specified in §15.209(a) is not required. In addition, radiated emissions which fall in the restricted bands, as defined in §15.205(a), must also comply with the radiated emission limits specified in §15.209(a) (see §15.205(c)).

TEST PROCEDURE

- a) Check the calibration of the measuring instrument using either an internal calibrator or a known signal from an external generator.
- b) Position the EUT without connection to measurement instrument. Turn on the EUT and connect its antenna terminal to measurement instrument via a low loss cable. Then set it to any one measured frequency within its operating range, and make sure the instrument is operated in its linear range.
- c) Set RBW to 100 kHz and VBW of spectrum analyzer to 300 kHz with a convenient frequency span including 100 kHz bandwidth from band edge.
- d) Measure the highest amplitude appearing on spectral display and set it as a reference level. Plot the graph with marking the highest point and edge frequency.
- e) Repeat above procedures until all measured frequencies were complete.

8.1.7 DEVIATION FROM STANDARD

No deviation.

8.1.8 TEST SETUP





8.1.9 EUT OPERATION CONDITIONS

The EUT tested system was configured as the statements of 2.4 Unless otherwise a special operating condition is specified in the follows during the testing.



8.1.10 TEST RESULTS

EUT :	ACIL H1	Model Name :	H1
Temperature :	25 °C	Relative Humidity :	60%
Pressure :	1012 hPa	Test Voltage :	DC 5V from USB Port

Frequency Band	Delta Peak to band emission (dBc)	> Limit (dBc)	Result
GFSK mode			
Left-band	52.841	20	Pass
Right-band	65.528	20	Pass
$\pi/4$ -DQPSK mode			
Left-band	56.512	20	Pass
Right-band	51.158	20	Pass
8-DPSK mode			
Left-band	56.512	20	Pass
Right-band	51.158	20	Pass



GFSK: Band Edge, Left Side

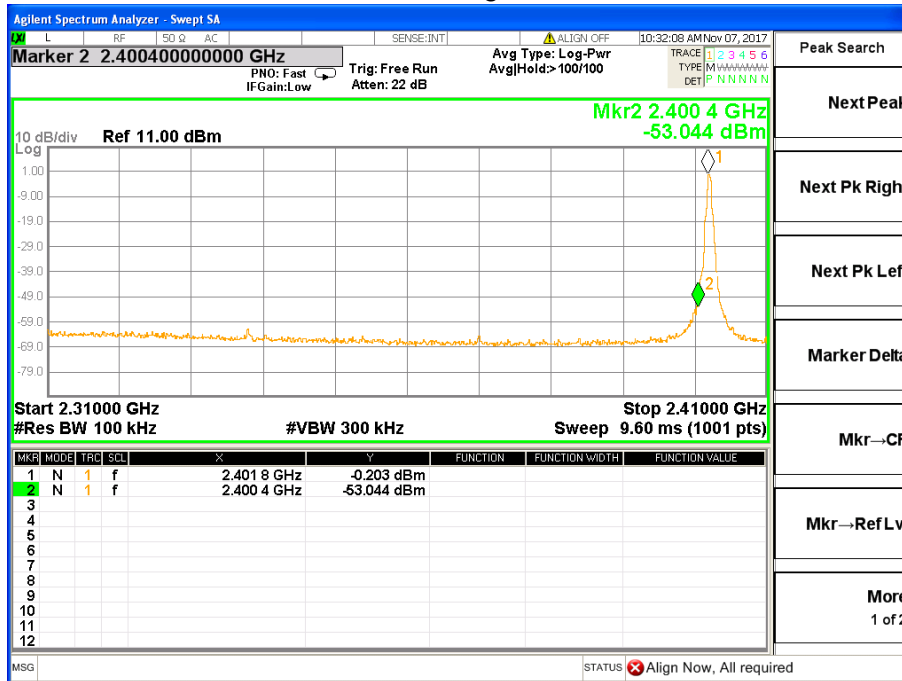

GFSK: Band Edge, Right Side

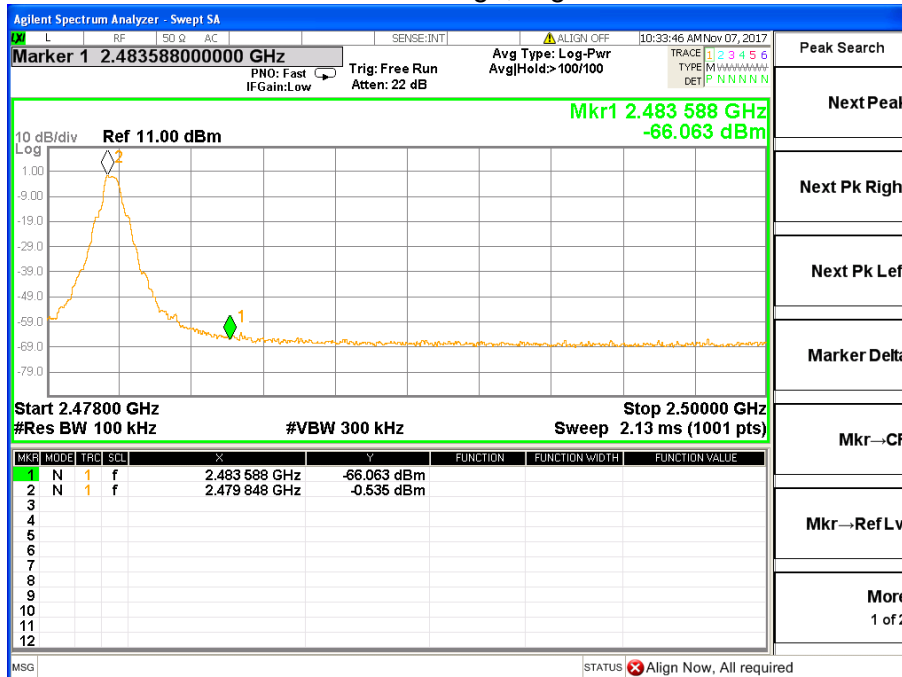



$\pi/4$ -DQPSK: Band Edge, Left Side

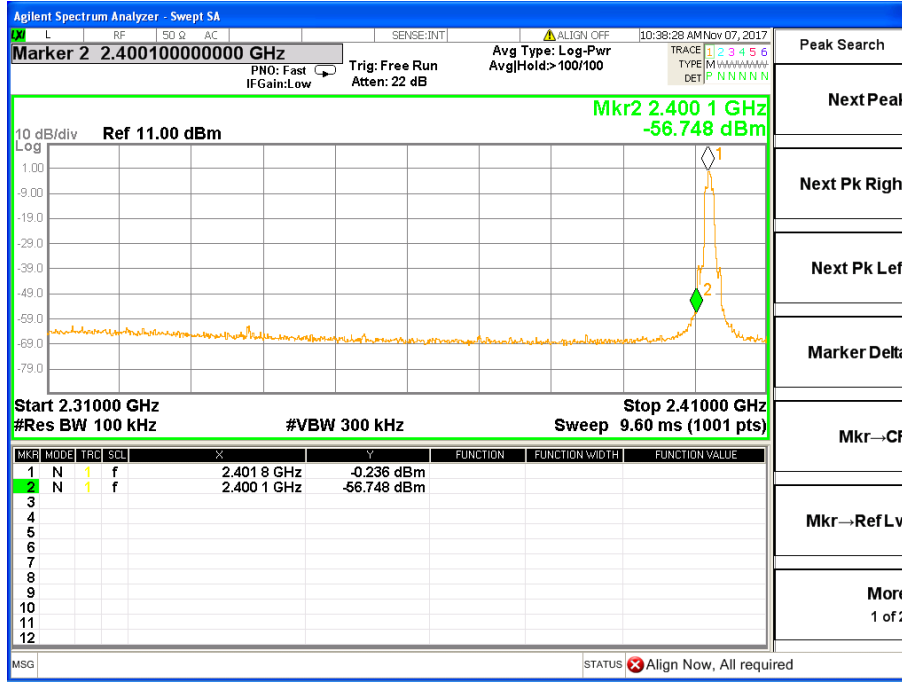

$\pi/4$ -DQPSK: Band Edge, Right Side

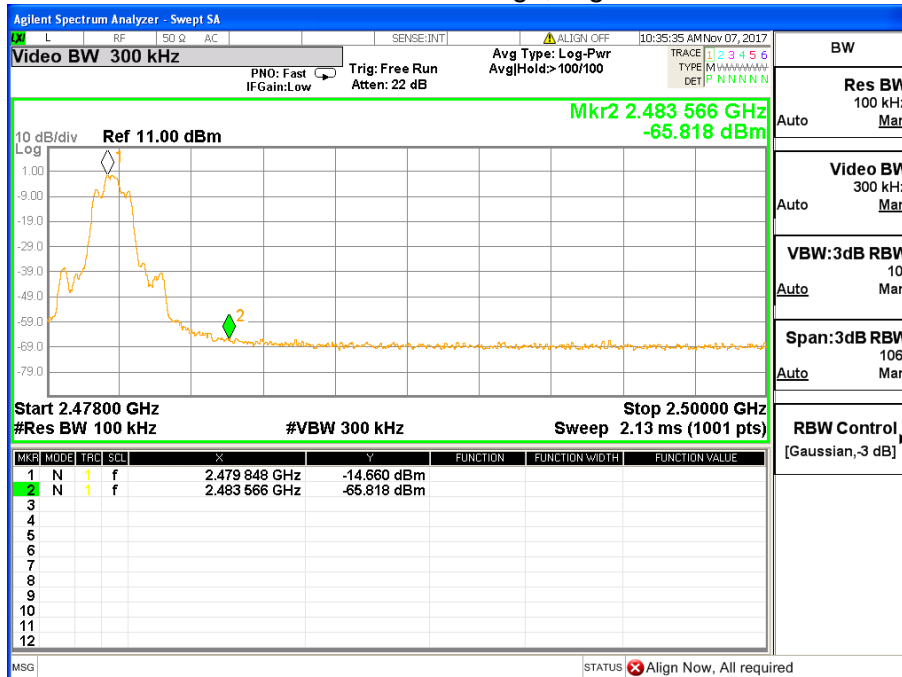



8-DPSK: Band Edge, Left Side

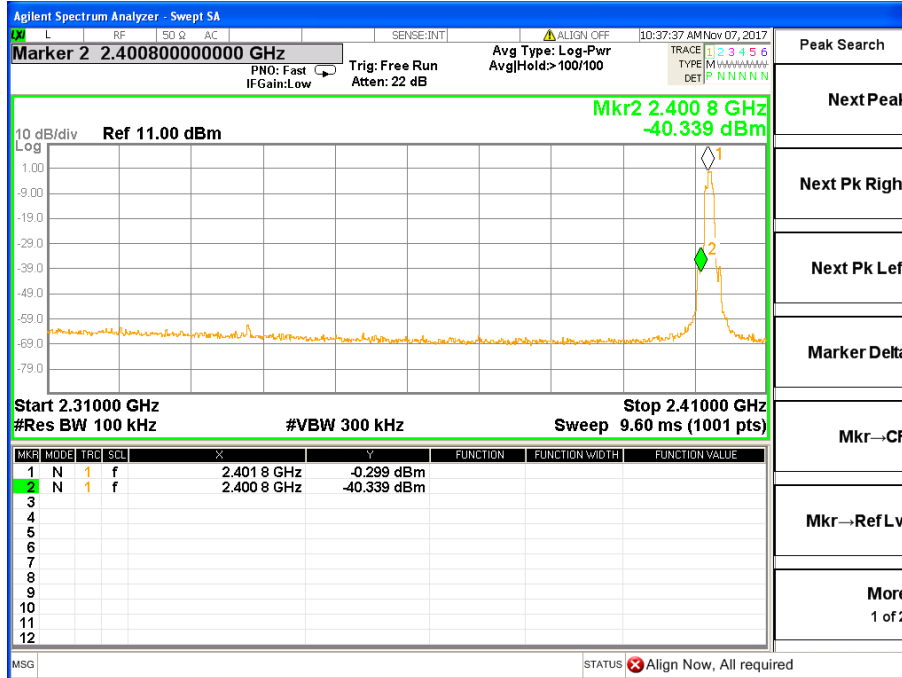

8-DPSK: Band Edge, Right Side

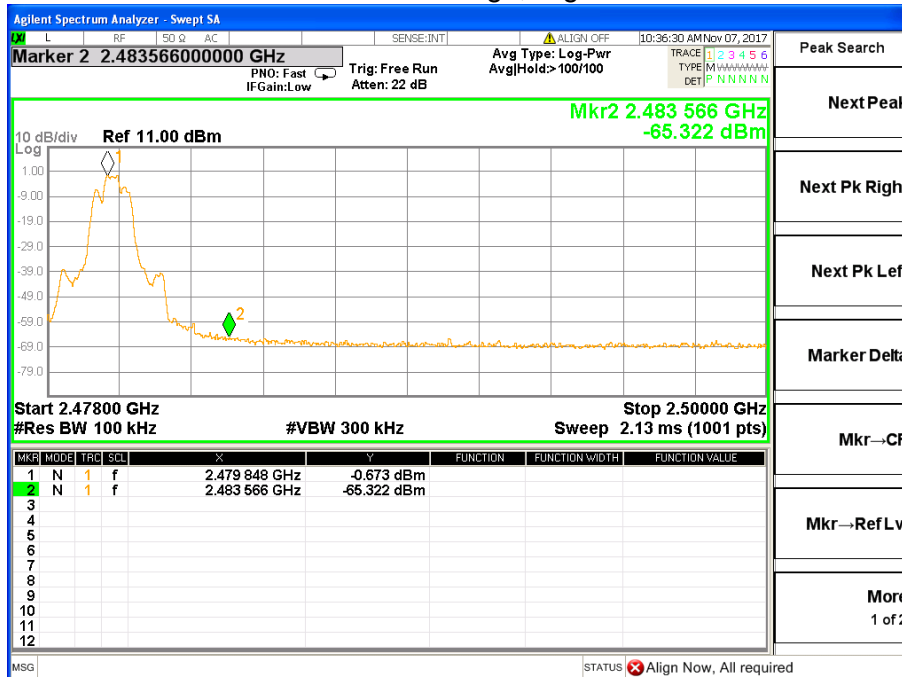



Hopping Mode

Frequency Band	Delta Peak to band emission (dBc)	> Limit (dBc)	Result
GFSK mode			
Left-band	58.233	20	Pass
Right-band	63.217	20	Pass
$\pi/4$ -DQPSK mode			
Left-band	50.88	20	Pass
Right-band	62.032	20	Pass
8-DPSK mode			
Left-band	49.637	20	Pass
Right-band	63.68	20	Pass



GFSK: Band Edge, Left Side

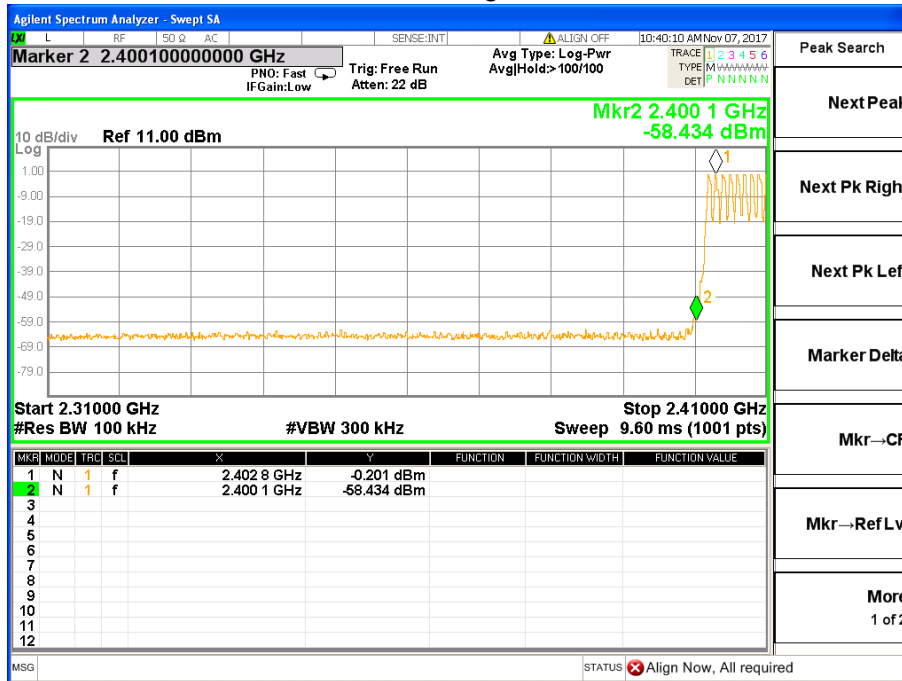

GFSK: Band Edge, Right Side

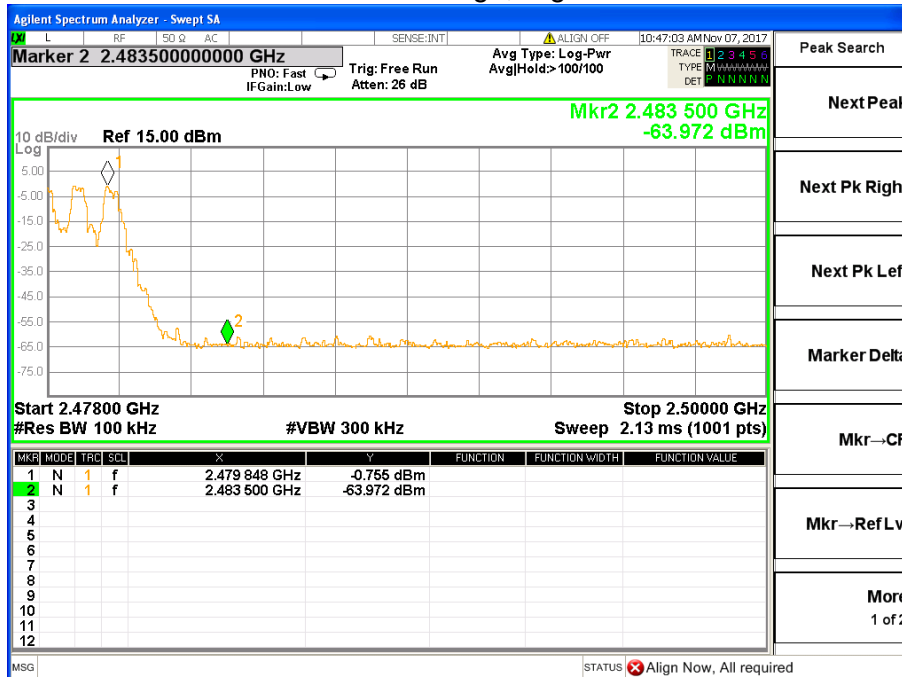



$\pi/4$ -DQPSK: Band Edge, Left Side

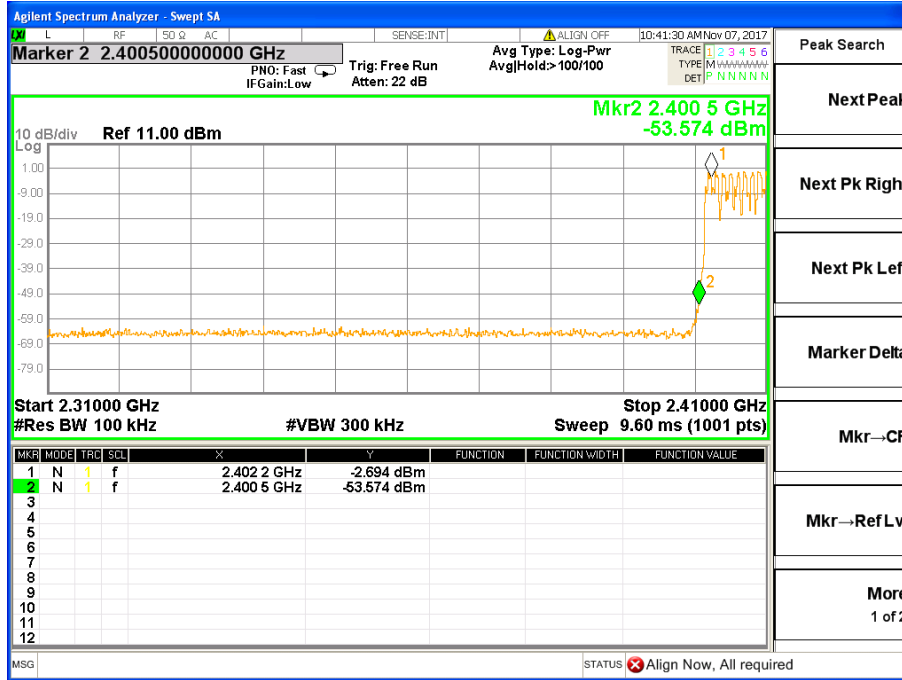

$\pi/4$ -DQPSK: Band Edge, Right Side

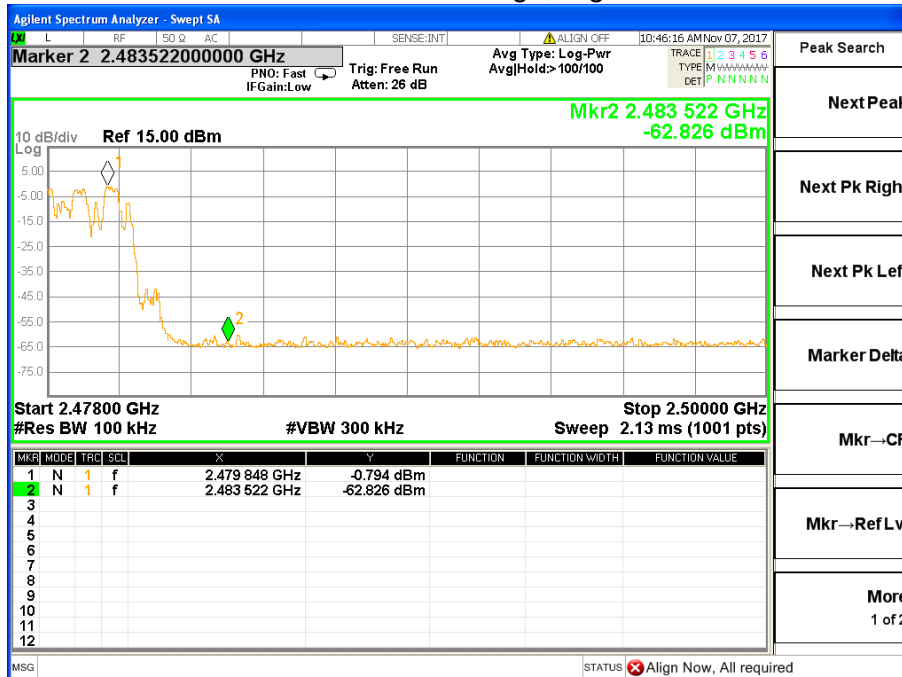



8-DPSK: Band Edge, Left Side

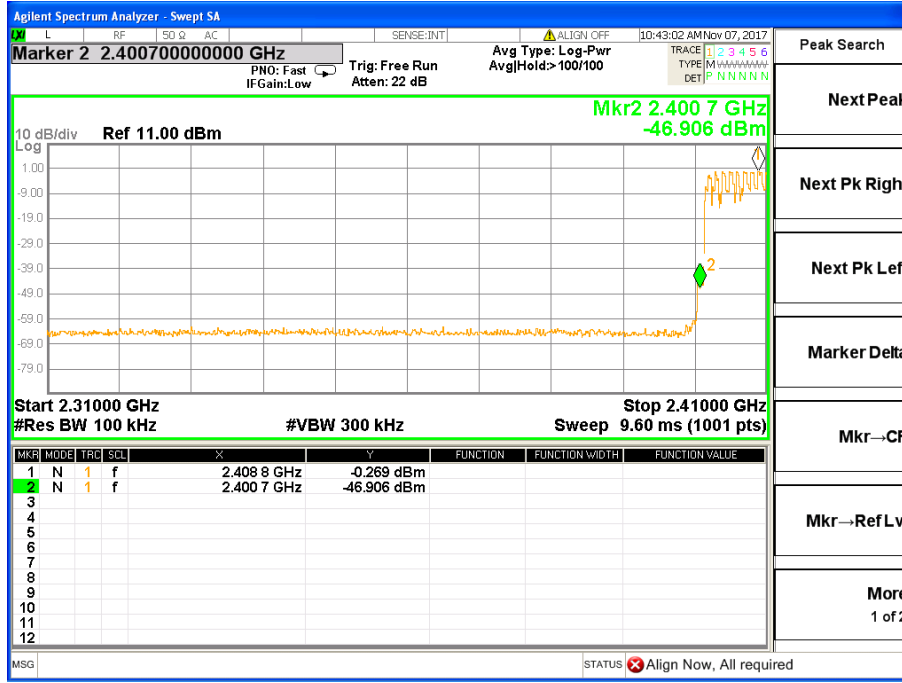

8-DPSK: Band Edge, Right Side

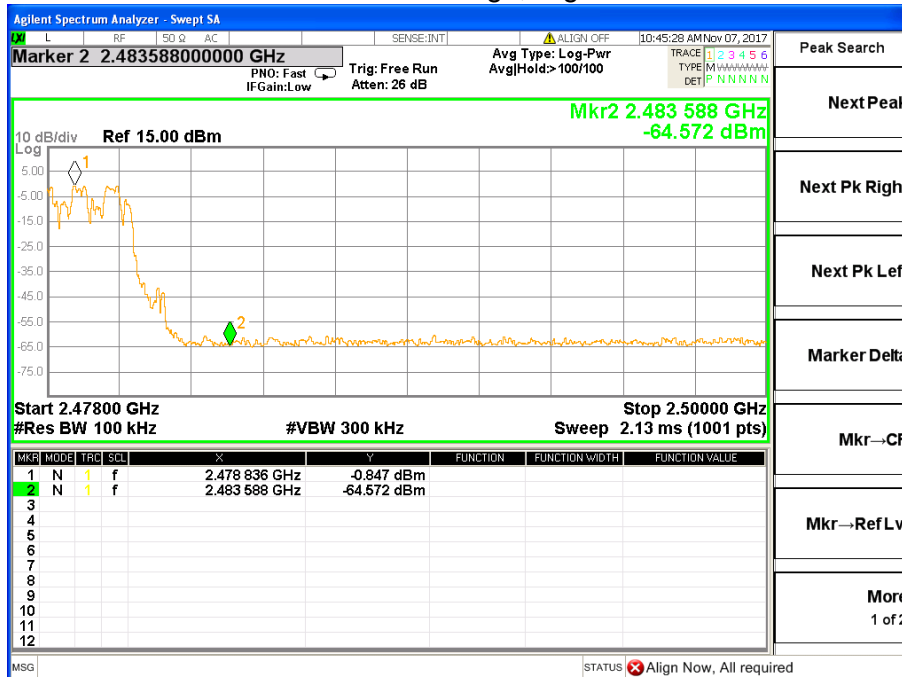



9. ANTENNA REQUIREMENT

9.1 STANDARD REQUIREMENT

15.203 requirement: For intentional device, according to 15.203: an intentional radiator shall be designed to ensure that no antenna other than that furnished by the responsible party shall be used with the device.

9.2 EUT ANTENNA

The EUT antenna is Chip antenna. It comply with the standard requirement. In case of replacement of broken antenna the same antenna type must be used.

----END OF REPORT----