

**ELECTROMAGNETIC EMISSIONS COMPLIANCE REPORT
INTENTIONAL RADIATOR CERTIFICATION TO
FCC PART 15 SUBPART B & C REQUIREMENT**

OF

LED Floodlight

MODEL No.: YDSP130601UL-20W-MW

FCC ID: 2AHGM-20W-MW

REPORT NO: ES160218008E

ISSUE DATE: February 23, 2016

Prepared for
NINGBO YUSING LIGHTING CO.,LTD.
No.1199,MINGGUANG RD.JIANGSHAN TOWN,NINGBO,CHINA

Prepared by
EMTEK (SHENZHEN) CO., LTD.
Building 69, Majialong Industry Zone, Nanshan District, Shenzhen, Guangdong, China
Tel: +86-755-26954280
Fax: +86-755-26954282

VERIFICATION OF COMPLIANCE

Applicant:	NINGBO YUSING LIGHTING CO.,LTD No.1199,MINGGUANG RD.JIANGSHAN TOWN,NINGBO,CHINA
Product Description:	LED Floodlight
Model Number:	YDSP130601UL-20W-MW
File Number:	ES160218008E
Date of Test:	February 18, 2016 to February 22, 2016

We hereby certify that:

The above equipment was tested by EMTEK (SHENZHEN) CO., LTD. The test data, data evaluation, test procedures, and equipment configurations shown in this report were made in accordance with the procedures given in ANSI C63.10 (2013) and the energy emitted by the sample EUT tested as described in this report is in compliance with conducted and radiated emission limits of FCC Rules Part 15.249(2015).

The test results of this report relate only to the tested sample identified in this report.

Date of Test : February 18, 2016 to February 22, 2016

Prepared by : 
Jack Li/Editor

Reviewer : 
Joe Xia/Supervisor

Approve & Authorized Signer : 
Lisa Wang/Manager

TABLE OF CONTENTS

1. GENERAL INFORMATION.....	4
1.1. Product Description.....	4
1.2. Related Submittal(s) / Grant (s)	4
1.3. Test Methodology	4
1.4. Special Accessories	4
1.5. Equipment Modifications.....	4
1.6. Test Facility.....	5
1.7. Measurement Uncertainty	5
2. SYSTEM TEST CONFIGURATION	6
2.1. EUT Configuration	6
2.2. EUT Exercise	6
2.3. Requirement for Compliance	6
2.4. Configuration of Tested System.....	8
2.5. Description of support units.....	8
3. SUMMARY OF TEST RESULTS	9
4. DESCRIPTION OF TEST MODES.....	9
5. CONDUCTED EMISSIONS TEST	10
5.1. Measurement Procedure.....	10
5.2. Measurement Equipment Used:.....	10
5.3. Measurement Equipment Used	10
5.4. Measurement Equipment Used	10
6. RADIATED EMISSION TEST	15
6.1. Measurement Procedure.....	15
6.2. Measurement Equipment Used:	15
6.3. Test SET-UP.....	16
6.4. Radiated Measurement Result	16
7. BAND EDGES MEASUREMENT.....	22
7.1. Standard Applicable	22
7.2. Measurement Procedure.....	22
7.3. Measurement Equipment	22
7.4. Test Setup.....	22
7.5. Test Results	22
8. ANTENNA APPLICATION.....	27
8.1. Standard Applicable	27
8.2. Antenna Construction	27

1. GENERAL INFORMATION

1.1. Product Description

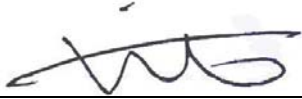
The EUT is a short range, lower power, Details of technical specification, refers to the description in follows:

- a. Operating frequency: 5752.57MHz
- b. Number of Channel: 1
- c. Antenna Designation: PCB antenna
- d. Modulation: FSK
- e. Antenna Gain: 0dbi
- f. Power Supply: 100-240V/AC, 50/60Hz

1.2. Related Submittal(s) / Grant (s)

This submittal(s) (test report) is intended for FCC ID: 2AHGM-20W-MW filing to comply with Section 15.249 of the FCC Part 15 Subpart C Rules.

1.3. Test Methodology

Both conducted and radiated testing were performed according to the procedures in ANSI C63.10 -2013. Radiated testing was performed at an antenna to EUT distance 3 meters.

1.4. Special Accessories

Not available for this EUT intended for grant.

1.5. Equipment Modifications

Not available for this EUT intended for grant.

1.6. Test Facility

Site Description	
EMC Lab.	<p>: Accredited by CNAS, 2013.10.29 The certificate is valid until 2016.10.29 The Laboratory has been assessed and proved to be in compliance with CNAS-CL01:2006(identical to ISO/IEC17025:2005) The Certificate Registration Number is L2291.</p> <p>Accredited by TUV Rheinland Shenzhen 2010.5.25 The Laboratory has been assessed according to the requirements ISO/IEC 17025.</p> <p>Accredited by FCC, April 17, 2013 The Certificate Registration Number is 406365.</p> <p>Accredited by Industry Canada, November 29, 2012 The Certificate Registration Number is 46405-4480.</p>
Name of Firm	: EMTEK (SHENZHEN) CO., LTD
Site Location	: Bldg 69, Majialong Industry Zone, Nanshan District, Shenzhen, Guangdong, China

1.7. Measurement Uncertainty

Conducted Emission Uncertainty	: 2.96dB(9k~150kHz Conduction 1#) 2.74dB(150k-30MHz Conduction 1#)
Radiated Emission Uncertainty (3m Chamber)	: 3.78dB (30M~1GHz Polarize: H) 4.27dB (30M~1GHz Polarize: V) 4.46dB (1~6GHz) 4.96dB (6~40GHz)

2. SYSTEM TEST CONFIGURATION

2.1.EUT Configuration

The EUT configuration for testing is installed on RF field strength measurement to meet the Commissions requirement and operating in a manner which intends to maximize its emission characteristics in a continuous normal application.

2.2.EUT Exercise

The EUT (LED Floodlight) has been tested under Normal Operating and standby condition. No software used to control the EUT for staying in continuous transmitting and receiving mode for testing.

2.3.Requirement for Compliance

2.3.1.Conducted Emissions (Not apply in the report)

According to §15.207, For intentional radiator device is designed to be connected to the public utility (AC) power line, the radio frequency voltage that is conducted back onto the AC power line on any frequency or frequencies within the band 150 kHz to 30 MHz shall not exceed the limits in the following table, as measured using a 50 μ H/50 ohms line impedance stabilization network (LISN). Compliance with the provisions of this paragraph shall be based on the measurement of the radio frequency voltage between each power line and ground at the power terminal.

Frequency(MHz)	Quasi-peak	Average
0.15-0.5	66-56	56-46
0.5-5.0	56	46
5.0-30.0	60	50

Note: 1. The lower limit shall apply at the transition frequencies
 2. The limit decreases in line with the logarithm of the frequency in the range of 0.15 to 0.50MHz.

2.3.2. Radiated Emissions

(a) FCC Part 15, Subpart C Section 15.209 limit of radiated emission for frequency below 1000GHz. The emissions from an intentional radiator shall not exceed the field strength level specified in the following table:

Frequency (MHz)	Field strength $\mu\text{V/m}$	Distance(m)	Field strength at 3m $\text{dB}\mu\text{V/m}$
30-88	100	3	40.0
88-216	150	3	43.5
216-960	200	3	46.0
Above 960	500	3	54.0

Remark:
 1. Emission level in $\text{dB}\mu\text{V/m}=20 \log (\mu\text{V/m})$
 2. Measurement was performed at an antenna to the closed point of EUT distance of meters.

(b) FCC Part 15, Section 15.35(b) limit of radiated emission for frequency above 1000MHz

Frequency(MHz)	$\text{dB}\mu\text{V/m(at 3m)}$	
	PEAK	AVERAGE
Above 1000	74.0	54.0

(c) FCC Part 15, Subpart C Section 15.249(a). The field strength of emissions from intentional radiators operated within these frequency bands shall comply with the following:

Frequency(MHz)	Filed Strength of Fundamental(at 3m)		Filed Strength of Harmonics (at 3m)	
	PEAK	AVERAGE	PEAK	AVERAGE
902-928	114.0	94.0	74.0	54.0
2400-2483.5	114.0	94.0	74.0	54.0
5725-5875	114.0	94.0	74.0	54.0
24000-24250	128.0	108.0	88.0	68.0

(d) Band edge

Emission radiated outside of the specified frequency bands, except for harmonics, shall be attenuated by at least 50dB below the level of the fundamental or to the general radiated emission limits in section 15.209, whichever is the lesser attenuation.

Frequency Range(MHz)	Limit($\text{dB}\mu\text{V/m}$)	
	Peak	AV
902-928	74.0	54.0
2400-2483.5		
5725-5850		
24000-24250		

2.3.3. Antenna Requirement

For intentional device, according to §15.203, an intentional radiator shall be designed to ensure that no antenna other than that furnished by the responsible party shall be used with the device.

2.4.Configuration of Tested System

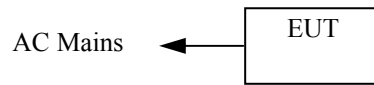

2.5.Description of support units

The EUT has been tested as an independent unit together with other necessary accessories or support units. The following support units or accessories were used to form a representative test configuration during the tests.

Item	Equipment	Mfr/Brand	Model/Type No.	FCC ID	Series No.	Note
1.	LED Floodlight	N/A	YDSP130601UL-20W-MW	2AHGM-20W-MW	N/A	EUT
Note: Unless otherwise denoted as EUT in 『Remark』 column , device(s) used in tested system is a support equipment.						

3. SUMMARY OF TEST RESULTS

FCC Rules	Description Of Test	Result
§ 15.249(a), § 15.249(d) § 15.249(e), § 15.209	Radiated Emission	Compliant
§15.207	Conducted Emission	Compliant
§15.249	Band Edge	Compliant
§15.203	Antenna Requirement	Compliant

4. DESCRIPTION OF TEST MODES

Continuously operating mode

Test Mode	Frequency(MHz)
TX	5752.57
\	\

5. CONDUCTED EMISSIONS TEST

5.1.Measurement Procedure

- The EUT was placed on a table which is 0.8m above ground plane.
- Maximum procedure was performed on the three highest emissions to ensure EUT compliance.
- Repeat above procedures until all frequency measured were complete.

5.2.Measurement Equipment Used:

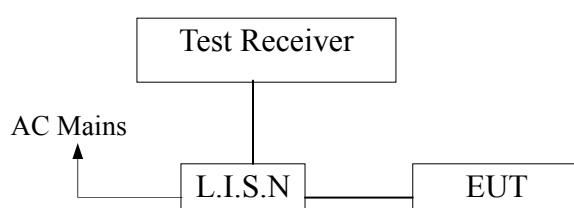

5.3.Measurement Equipment Used

EQUIPMENT TYPE	MFR	MODEL NUMBER	SERIAL NUMBER	Last Cal.	Cal. Interval
Test Receiver	Rohde & Schwarz	ESCS30	828985/018	05/16/2015	1 Year
L.I.S.N.	Rohde & Schwarz	ENV216	101161	05/16/2015	1 Year
50Ω Coaxial Switch	Anritsu	MP59B	M20531	05/16/2015	1 Year
Pulse Limiter	Rohde & Schwarz	ESH3-Z2	100006	05/16/2015	1 Year

5.4.Measurement Equipment Used

Pass.

Please refer to the following data.

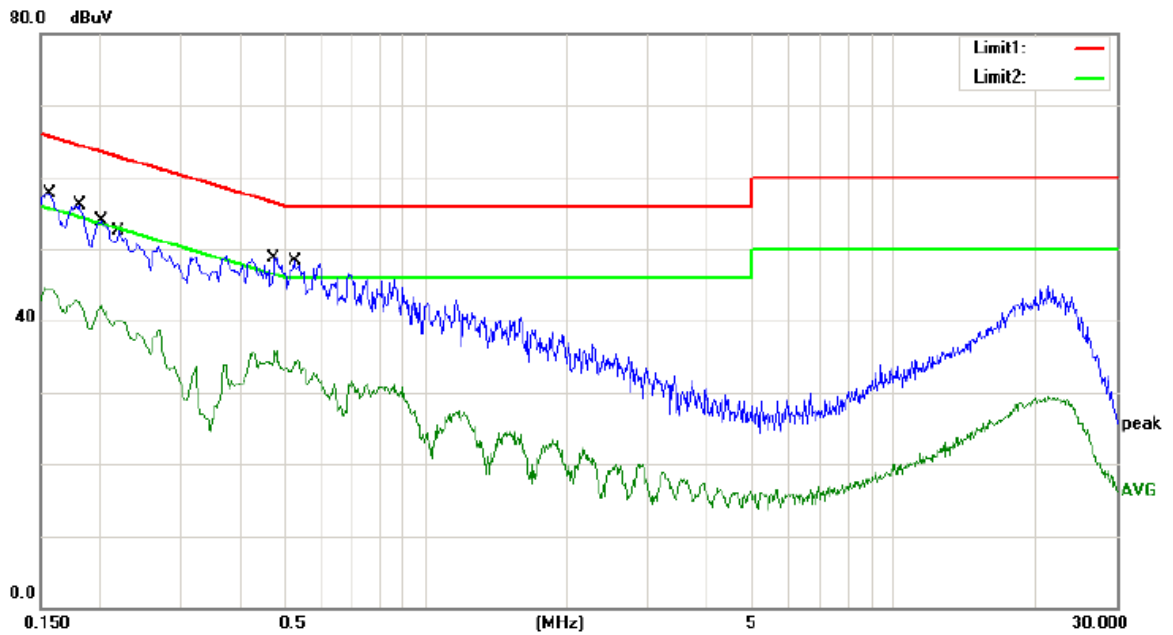

Site site #1

Phase: **N**

Temperature: 22

Limit: (CE)FCC PART 15 class B_QP

Power: AC 120V/60Hz

Humidity: 50 %

Mode: ON

Note:

No.	Mk.	Freq. MHz	Reading Level dBuV	Correct Factor dB	Measure- ment dBuV	Limit dBuV	Over dB	Detector	Comment
1		0.1580	46.60	11.00	57.60	65.57	-7.97	QP	
2		0.1580	33.40	11.00	44.40	55.57	-11.17	AVG	
3		0.1820	45.10	11.00	56.10	64.39	-8.29	QP	
4		0.1820	31.40	11.00	42.40	54.39	-11.99	AVG	
5		0.2020	42.90	11.00	53.90	63.53	-9.63	QP	
6		0.2020	30.80	11.00	41.80	53.53	-11.73	AVG	
7		0.2220	41.40	11.00	52.40	62.74	-10.34	QP	
8		0.2220	29.10	11.00	40.10	52.74	-12.64	AVG	
9		0.4740	37.60	11.00	48.60	56.44	-7.84	QP	
10		0.4740	24.90	11.00	35.90	46.44	-10.54	AVG	
11	*	0.5260	37.20	11.00	48.20	56.00	-7.80	QP	
12		0.5260	22.80	11.00	33.80	46.00	-12.20	AVG	

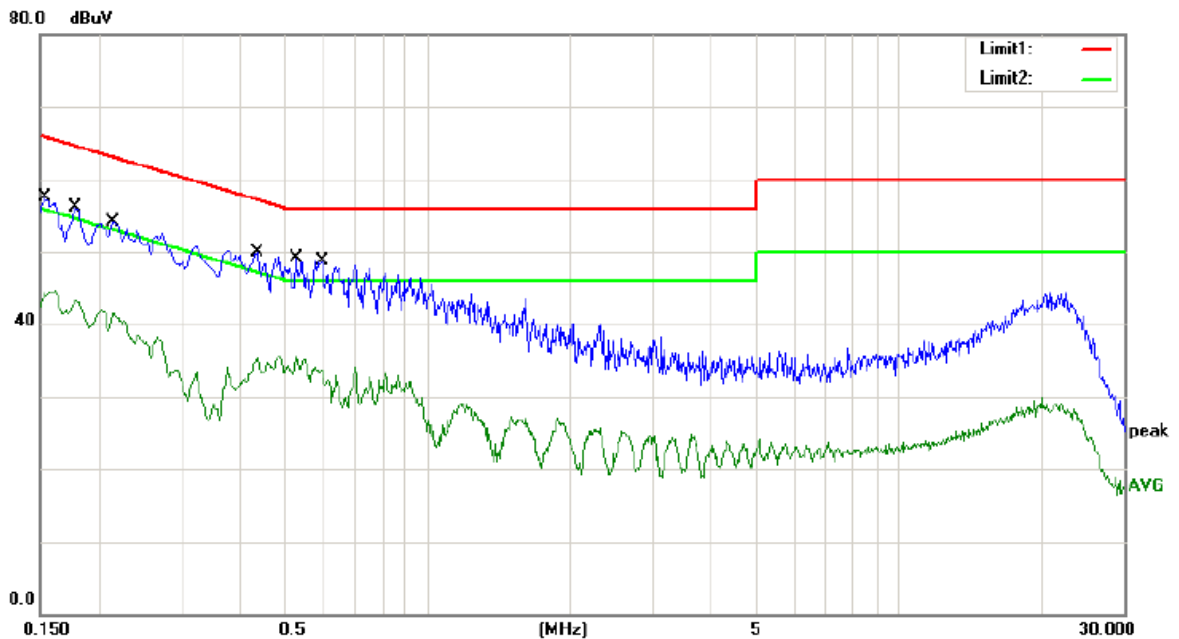

Site site #1 Phase: **L1** Temperature: 22
 Limit: (CE)FCC PART 15 class B_QP Power: AC 120V/60Hz Humidity: 50 %
 Mode: ON
 Note:

No.	Mk.	Freq.	Reading Level	Correct Factor	Measurement	Limit	Over	Detector	Comment
		MHz	dBuV	dB	dBuV	dBuV	dB		
1		0.1540	46.50	11.00	57.50	65.78	-8.28	QP	
2		0.1540	33.30	11.00	44.30	55.78	-11.48	AVG	
3		0.1780	45.10	11.00	56.10	64.58	-8.48	QP	
4		0.1780	32.30	11.00	43.30	54.58	-11.28	AVG	
5		0.2140	43.00	11.00	54.00	63.05	-9.05	QP	
6		0.2140	30.50	11.00	41.50	53.05	-11.55	AVG	
7		0.4340	38.80	11.00	49.80	57.18	-7.38	QP	
8		0.4350	24.00	11.00	35.00	47.16	-12.16	AVG	
9	*	0.5260	38.10	11.00	49.10	56.00	-6.90	QP	
10		0.5260	24.30	11.00	35.30	46.00	-10.70	AVG	
11		0.5980	37.70	11.00	48.70	56.00	-7.30	QP	
12		0.5980	22.20	11.00	33.20	46.00	-12.80	AVG	

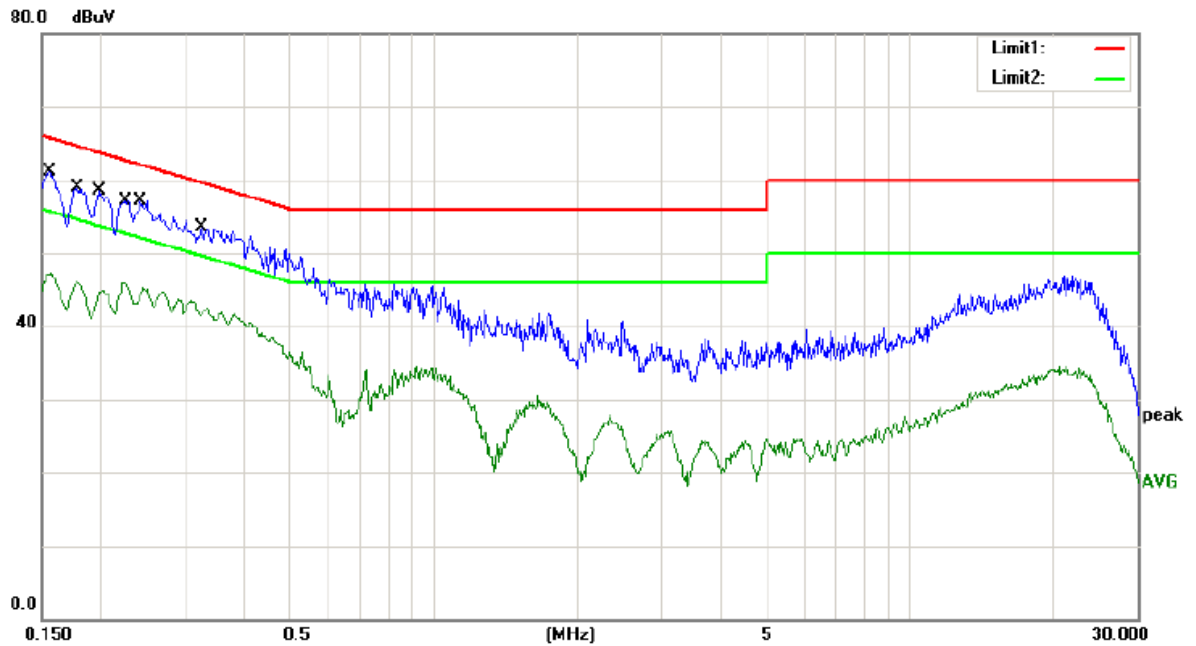

Site site #1 Phase: **L1** Temperature: 22
 Limit: (CE)FCC PART 15 class B_QP Power: AC 240V/60Hz Humidity: 50 %
 Mode: ON
 Note:

No.	Mk.	Freq. MHz	Reading Level dBuV	Correct Factor dB	Measure- ment dBuV	Limit dBuV	Over dB	Detector	Comment
1	*	0.1554	50.00	11.00	61.00	65.71	-4.71	QP	
2		0.1554	36.10	11.00	47.10	55.71	-8.61	AVG	
3		0.1780	47.90	11.00	58.90	64.58	-5.68	QP	
4		0.1780	35.00	11.00	46.00	54.58	-8.58	AVG	
5		0.1980	47.40	11.00	58.40	63.69	-5.29	QP	
6		0.1980	33.60	11.00	44.60	53.69	-9.09	AVG	
7		0.2260	46.10	11.00	57.10	62.60	-5.50	QP	
8		0.2260	34.90	11.00	45.90	52.60	-6.70	AVG	
9		0.2420	46.10	11.00	57.10	62.03	-4.93	QP	
10		0.2420	33.30	11.00	44.30	52.03	-7.73	AVG	
11		0.3260	42.40	11.00	53.40	59.55	-6.15	QP	
12		0.3260	30.70	11.00	41.70	49.55	-7.85	AVG	

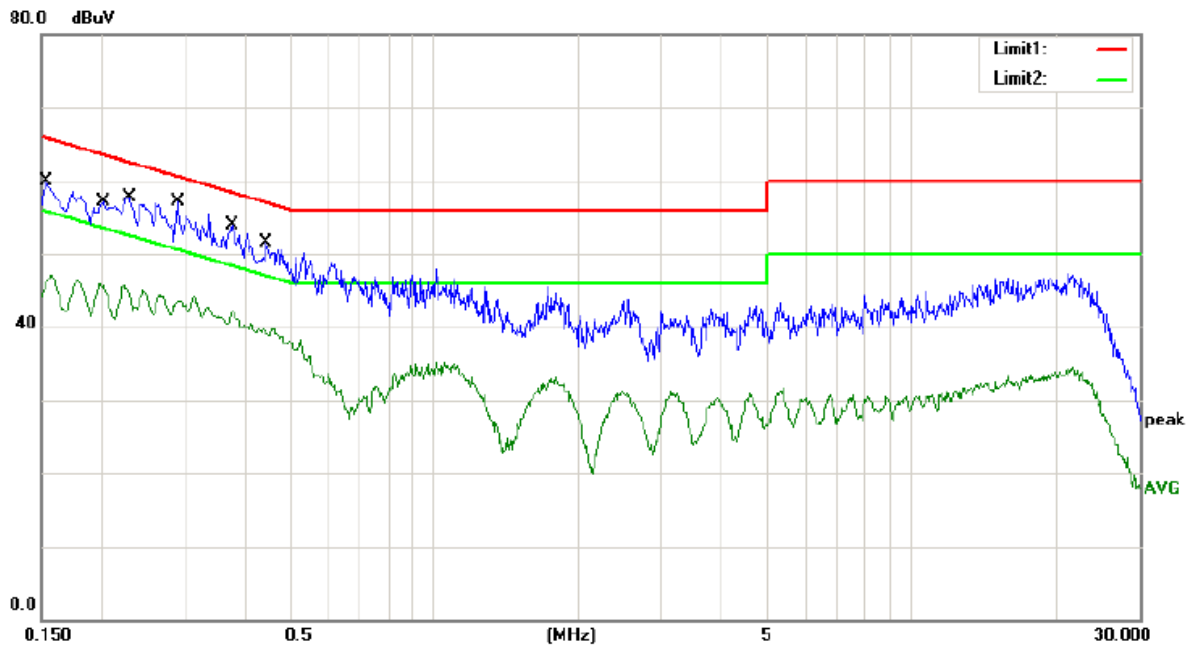

Site site #1 Phase: **N** Temperature: 22
 Limit: (CE)FCC PART 15 class B_QP Power: AC 240V/60Hz Humidity: 50 %
 Mode: ON
 Note:

No.	Mk.	Freq. MHz	Reading Level dBuV	Correct Factor dB	Measure- ment dBuV	Limit dBuV	Over dB	Detector	Comment
1		0.1540	48.80	11.00	59.80	65.78	-5.98	QP	
2		0.1540	35.10	11.00	46.10	55.78	-9.68	AVG	
3		0.2020	46.00	11.00	57.00	63.53	-6.53	QP	
4		0.2020	34.40	11.00	45.40	53.53	-8.13	AVG	
5		0.2300	46.70	11.00	57.70	62.45	-4.75	QP	
6		0.2300	33.40	11.00	44.40	52.45	-8.05	AVG	
7		0.2900	43.00	11.00	54.00	60.52	-6.52	QP	
8		0.2900	32.50	11.00	43.50	50.52	-7.02	AVG	
9	*	0.3780	42.80	11.00	53.80	58.32	-4.52	QP	
10		0.3780	31.00	11.00	42.00	48.32	-6.32	AVG	
11		0.4460	40.50	11.00	51.50	56.95	-5.45	QP	
12		0.4460	28.10	11.00	39.10	46.95	-7.85	AVG	

6. RADIATED EMISSION TEST

6.1.Measurement Procedure

- d. All measurements were made at 3 meters.
- e. The EUT was placed on the top of a rotating table 0.8 meters above the ground at a 3m meter open area test site. The table was rotated 360 degrees to determine the position of the highest radiation.
- f. The height of the equipment or of the substitution antenna shall be 0.8 m; the height of the test antenna shall vary between 1 m to 4 m. Both horizontal and vertical polarizations of the antenna are set to make the measurement.

The frequency range from 30MHz to 1000MHz was pre-scanned with a peak detector (RBW=100kHz, VBW=300kHz) and all final readings of measurement from Test Receiver are Quasi-Peak values(Quasi Peak detector used with a bandwidth of 120 kHz).

The frequency range above 1GHz the measuring instrument use RBW=1 MHz and VBW=3 MHz with Peak Detector for Peak Values, and use RBW=1 MHz and VBW=10 Hz with Peak Detector for Average Values.

6.2.Measurement Equipment Used:

EQUIPMENT TYPE	MFR	MODEL NUMBER	SERIAL NUMBER	Last Cal.	Cal. Interval
EMI Test Receiver	Rohde & Schwarz	ESCI	101414	May 16, 2015	1 Year
EMI Test Receiver	Rohde & Schwarz	FSV40	132.1-3008K39-10 0967-AP	May 16, 2015	1 Year
Loop Antenna	Schwarzbeck	FMZB 1519	1519-012	May 16, 2015	1 Year
Bilog Antenna	Schwarzbeck	VULB9163	660	May 16, 2015	1 Year
Horn Antenna	Schwarzbeck	BBHA 9120	1178	May 16, 2015	1 Year
Horn Antenna	Schwarzbeck	BBHA 9170	RS1307229170547	May 16, 2015	1 Year
Horn Antenna	AHS/USA	SAS-573	184	May 16, 2015	1 Year
Pre-Amplifier	LUNAR-EM	LNA30M3G-25	J10100000071	May 16, 2015	1 Year
Pre-Amplifier	Lunar EM	LNA1G18-48	J1011131010001	May 16, 2015	1 Year
Pre-Amplifier	Lunar EM	LNA18G26-40	J1012131010001	May 16, 2015	1 Year
Pre-Amplifier	Lunar EM	LNA26G40-40	J1013131028001	May 16, 2015	1 Year
Cable	H+B	NmSm-2-C15201	\	May 16, 2015	1 Year
Cable	H+B	NmNm-7-C15702	\	May 16, 2015	1 Year
Cable	H+B	NmSm-05-C15052	\	May 16, 2015	1 Year
Cable	H+B	SUCOFLEX104	MY14871/4	May 16, 2015	1 Year
Cable	H+B	BLU18A-NmSm-6500	D8501	May 16, 2015	1 Year
Cable	A.H	SAC-40G-1	414	May 16, 2015	1 Year
Cable	A.H	SAC-40G-1	413	May 16, 2015	1 Year

6.3. Test SET-UP

(a) Radiated Emission Test Set-Up, Frequency Below 30MHz

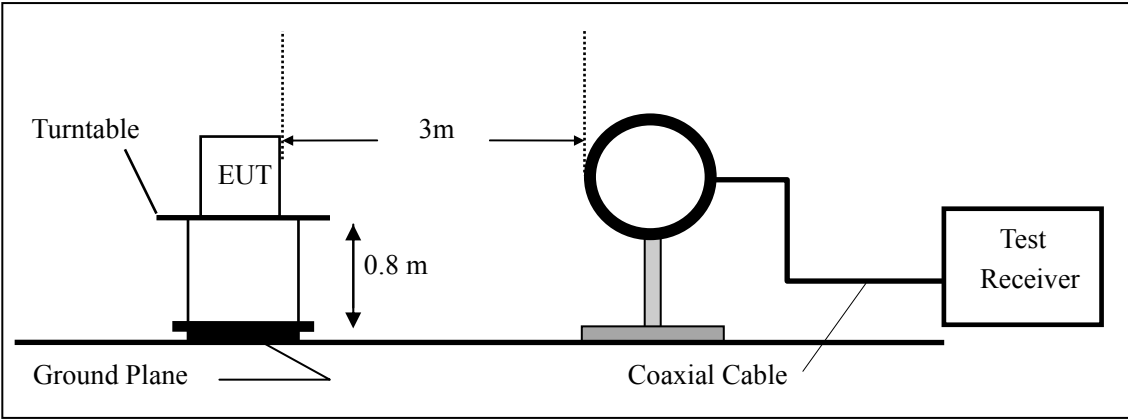

(b) Radiated Emission Test Set-Up, Frequency Below 1000MHz

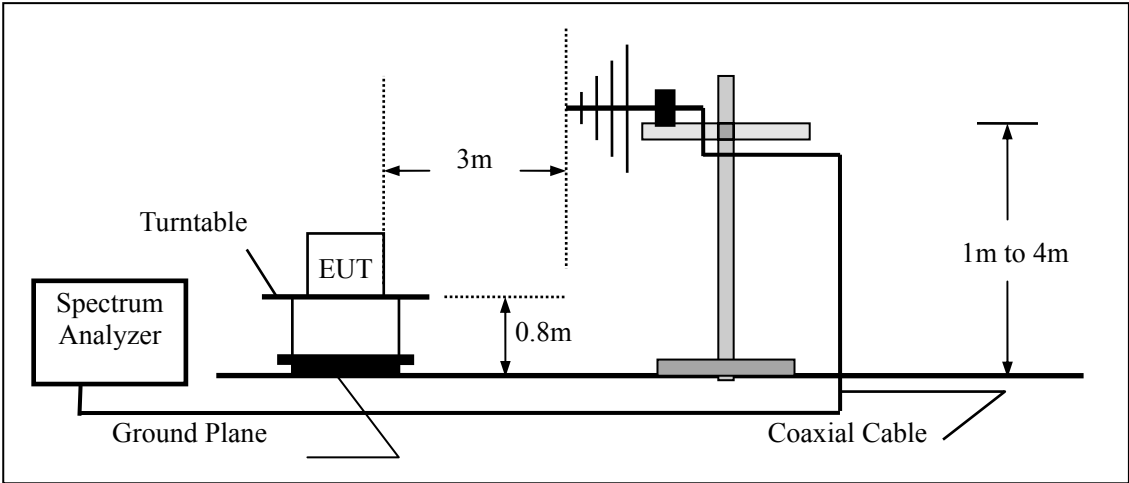

(c) Radiated Emission Test Set-Up, Frequency Above 1000MHz

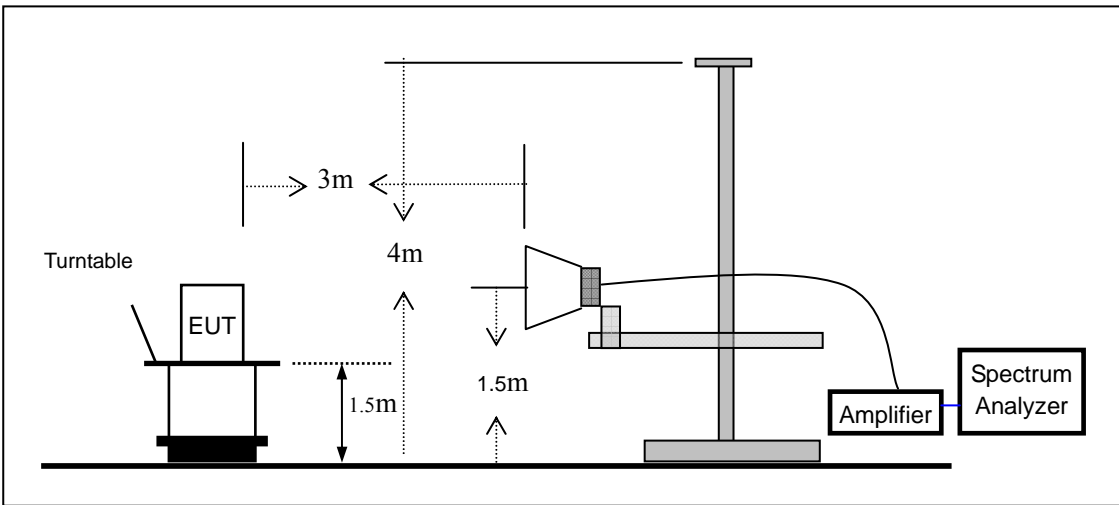

6.4. Radiated Measurement Result

30MHz-1GHz:

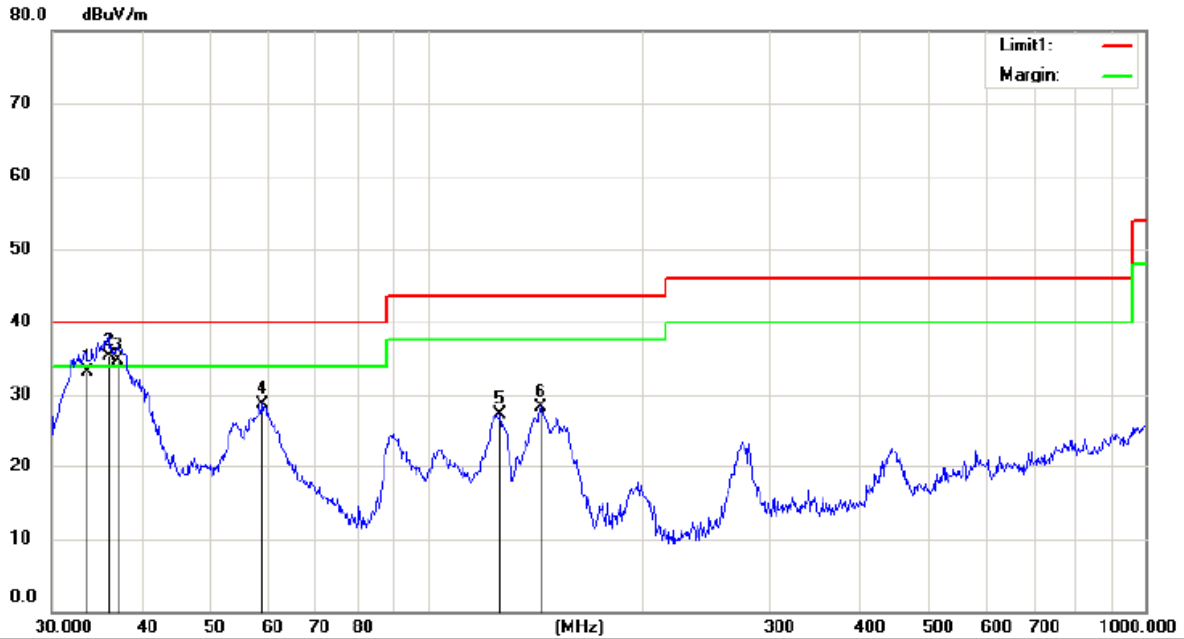

Site site #1 Polarization: **Vertical** Temperature: 20 C
 Limit: FCC Part15 Class B 3M Radiation Power: AC 240V/60Hz Humidity: 52 %
 Mode:ON
 Note:

No.	Mk.	Freq. MHz	Reading Level dBuV	Correct Factor dB	Measure- ment dBuV/m	Limit dBuV/m	Over dB	Detector	Antenna Height cm	Table Degree degree	Comment
1		33.5623	55.75	-22.55	33.20	40.00	-6.80	QP			
2	*	36.0007	57.92	-22.62	35.30	40.00	-4.70	QP			
3	!	37.0250	56.64	-21.94	34.70	40.00	-5.30	QP			
4		59.0251	50.43	-21.63	28.80	40.00	-11.20	QP			
5		126.3285	51.59	-24.29	27.30	43.50	-16.20	QP			
6		143.8293	54.51	-26.11	28.40	43.50	-15.10	QP			

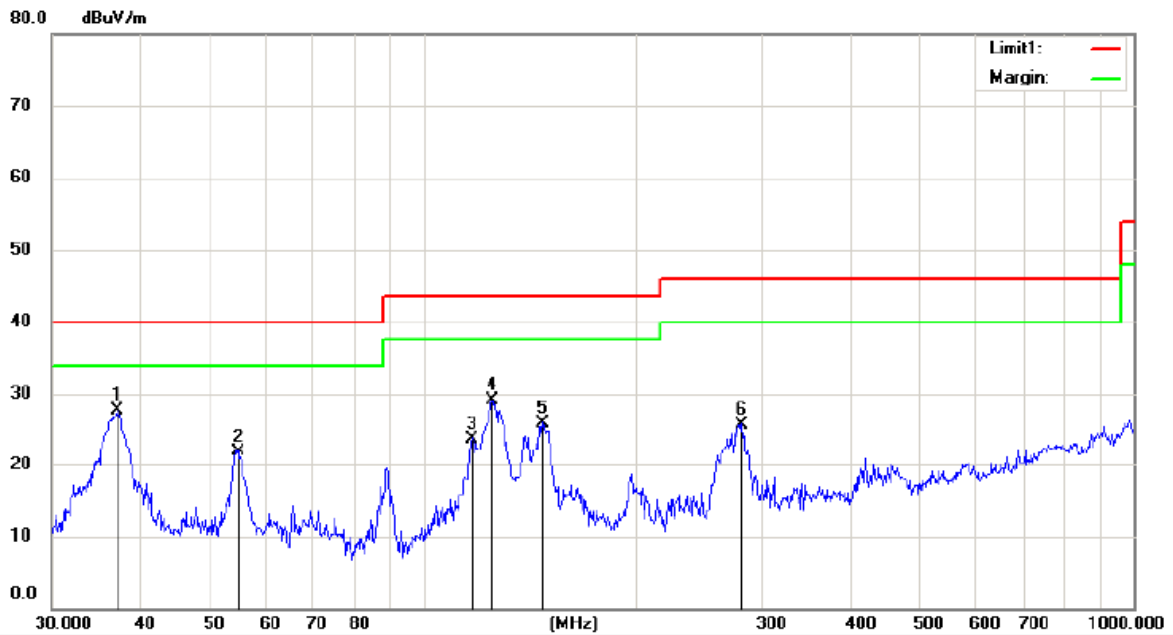

Site site #1 Polarization: *Horizontal* Temperature: 20 C

Limit: FCC Part15 Class B 3M Radiation
Mode:ON

Power: AC 240V/60Hz

Humidity: 52 %

Note:

No.	Mk.	Freq. MHz	Reading Level dBuV	Correct Factor dB	Measure- ment dBuV/m	Limit dBuV/m	Over dB	Antenna Height cm	Table Degree degree	Comment
1	*	37.0250	49.64	-21.94	27.70	40.00	-12.30	QP		
2		54.8348	41.76	-19.76	22.00	40.00	-18.00	QP		
3		117.3602	46.88	-23.08	23.80	43.50	-19.70	QP		
4		125.0065	53.07	-23.97	29.10	43.50	-14.40	QP		
5		147.4036	51.46	-25.46	26.00	43.50	-17.50	QP		
6		281.0074	45.17	-19.37	25.80	46.00	-20.20	QP		

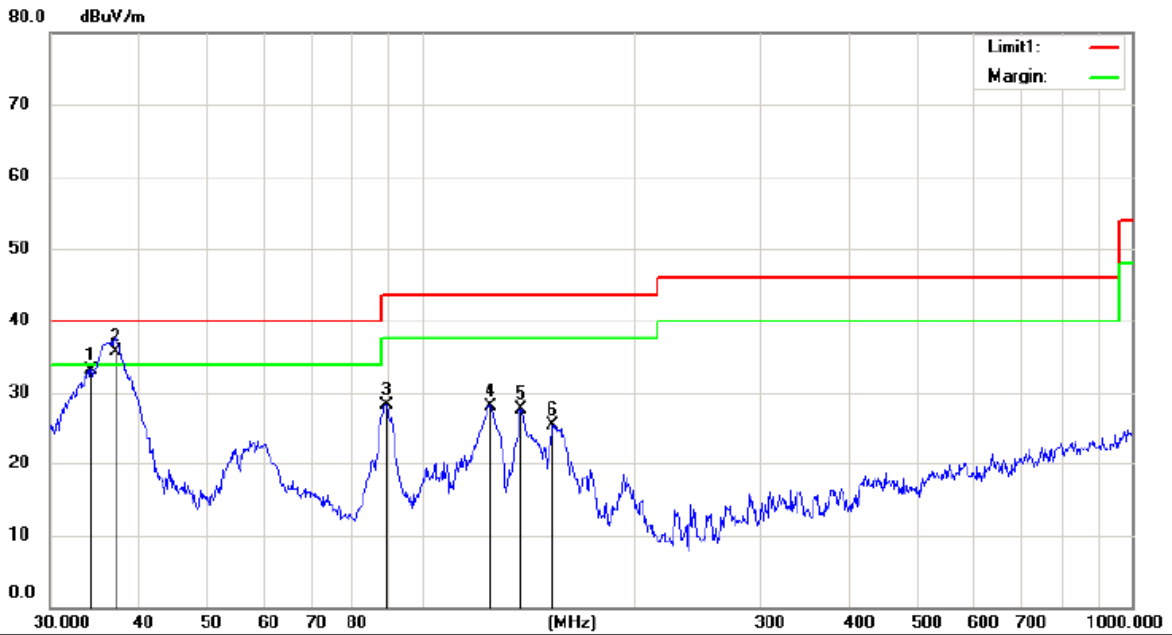

Site site #1 Polarization: *Vertical* Temperature: 20 C
 Limit: FCC Part15 Class B 3M Radiation Power: AC 120V/60Hz Humidity: 52 %
 Mode:ON
 Note:

No.	Mk.	Freq.	Reading Level	Correct Factor	Measurement	Limit	Over	Antenna Height	Table Degree	
		MHz	dBuV	dB	dBuV/m	dBuV/m	dB	cm	degree	Comment
1		34.2760	55.58	-22.38	33.20	40.00	-6.80	QP		
2	*	37.0250	57.64	-21.94	35.70	40.00	-4.30	QP		
3		89.2762	51.95	-23.55	28.40	43.50	-15.10	QP		
4		125.0065	52.17	-23.97	28.20	43.50	-15.30	QP		
5		137.9030	53.71	-26.01	27.70	43.50	-15.80	QP		
6		153.2002	50.77	-25.27	25.50	43.50	-18.00	QP		

Above 1GHz:

Operation Mode:	TX	Test Date :	Feb 22, 2016
Frequency Range:	1000-40000MHz	Temperature :	21 °C
Test Result:	PASS	Humidity :	55 %
Measured Distance:	3m	Test By:	YH

Freq. (MHz)	Ant.Pol	Emission Level (dBuV)		Limit 3m (dBuV/m)		Margin(dB)	
		H/V	PK	AV	PK	AV	PK
7563.000	V	47.61	32.12	74.00	54.00	-26.39	-21.88
11505.14	V	58.68	45.48	74.00	54.00	-15.32	-8.52
12166.00	V	53.21	37.83	74.00	54.00	-20.79	-16.17
14207.00	V	52.84	39.32	74.00	54.00	-21.16	-14.68
14940.00	V	54.61	43.15	74.00	54.00	-19.39	-10.85
16879.00	V	55.12	39.95	74.00	54.00	-18.88	-14.05
--	--	--	--	--	--	--	--
7393.000	H	49.14	32.25	74.00	54.00	-24.86	-21.75
8974.000	H	50.13	34.59	74.00	54.00	-23.87	-19.41
11505.14	H	61.17	46.22	74.00	54.00	-12.83	-7.78
12949.00	H	53.38	38.48	74.00	54.00	-20.62	-15.52
14328.00	H	53.38	38.62	74.00	54.00	-20.62	-15.38
15995.00	H	50.22	37.95	74.00	54.00	-23.78	-16.05
--	--	--	--	--	--	--	--

- Note:** (1) All Readings are Peak Value and AV.
(2) Emission Level= Reading Level+Probe Factor +Cable Loss
(3) The average measurement was not performed when the peak measured data under the limit of average detection.
(4)Data of measurement within this frequency range shown "--" in the table above means the reading of emissions are attenuated more than 20dB below the permissible limits or the field strength is too small to be measured

7. BAND EDGES MEASUREMENT

7.1. Standard Applicable

According to 15.249(d), out band emission except for harmonics shall be comply with §15.209 or at least attenuated by 50 dB below the level of the fundamental.

7.2. Measurement Procedure

Same as 6.1 Radiated Emission Measurement.

7.3. Measurement Equipment

Same as 6.2 Radiated Emission Measurement.

7.4. Test Setup

Same as 6.3 Radiated Emission Measurement.

7.5. Test Results

Pass

The test plots as following:

Lower band edge

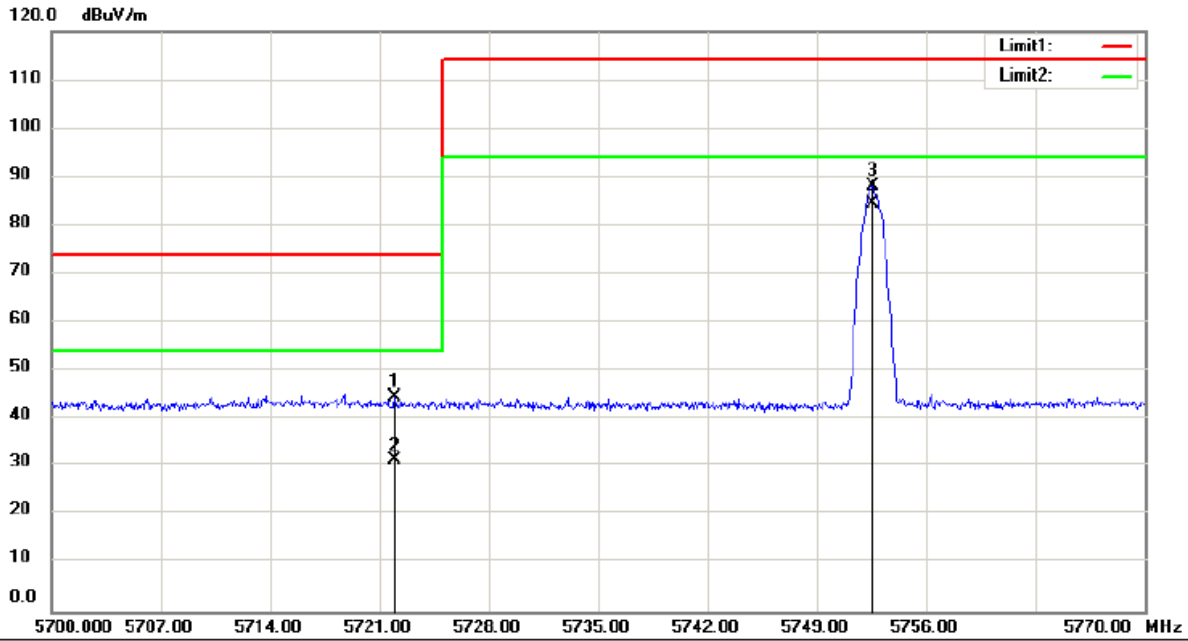

Site site #1 Polarization: *Vertical* Temperature: 24 C
 Limit: (RE)FCC PART 5G(Band edge) Power: AC 120V/60Hz Humidity: 53 %
 Mode:ON
 Note:

No.	Mk.	Freq. MHz	Reading Level dBuV	Correct Factor dB	Measure- ment dBuV/m	Limit dBuV/m	Over dB	Detector	Antenna Height cm	Table Degree	Comment
1		5721.980	58.35	-13.67	44.68	74.00	-29.32	peak			
2		5721.980	45.07	-13.67	31.40	54.00	-22.60	AVG			
3		5752.570	101.61	-13.63	87.98	114.00	-26.02	peak			
4	*	5752.570	98.23	-13.63	84.60	94.00	-9.40	AVG			

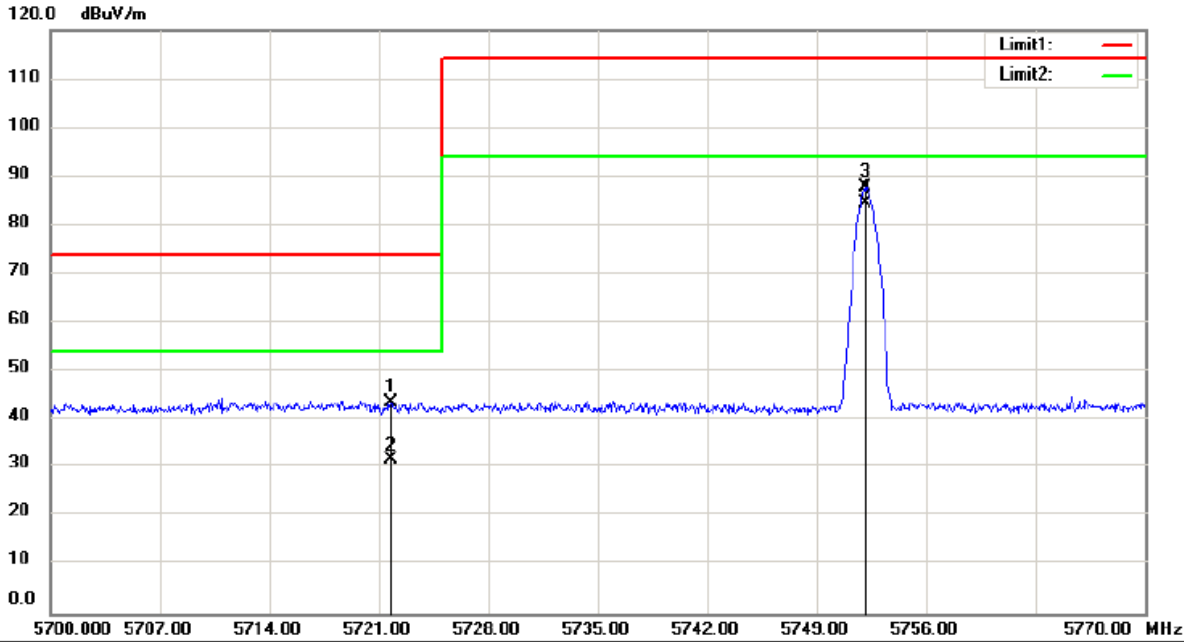

Site site #1 Polarization: **Horizontal** Temperature: 24 C
 Limit: (RE)FCC PART 5G(Band edge) Power: AC 120V/60Hz Humidity: 53 %
 Mode:ON
 Note:

No.	Mk.	Freq.	Reading Level	Correct Factor	Measurement	Limit	Over	Antenna Height	Table Degree	
		MHz	dBuV	dB	dBuV/m	dBuV/m	dB	cm	degree	Comment
1		5721.770	57.26	-13.67	43.59	74.00	-30.41			peak
2		5721.770	45.27	-13.67	31.60	54.00	-22.40			AVG
3		5752.570	101.35	-13.63	87.72	114.00	-26.28			peak
4	*	5752.570	98.13	-13.63	84.50	94.00	-9.50			AVG

Upper band edge

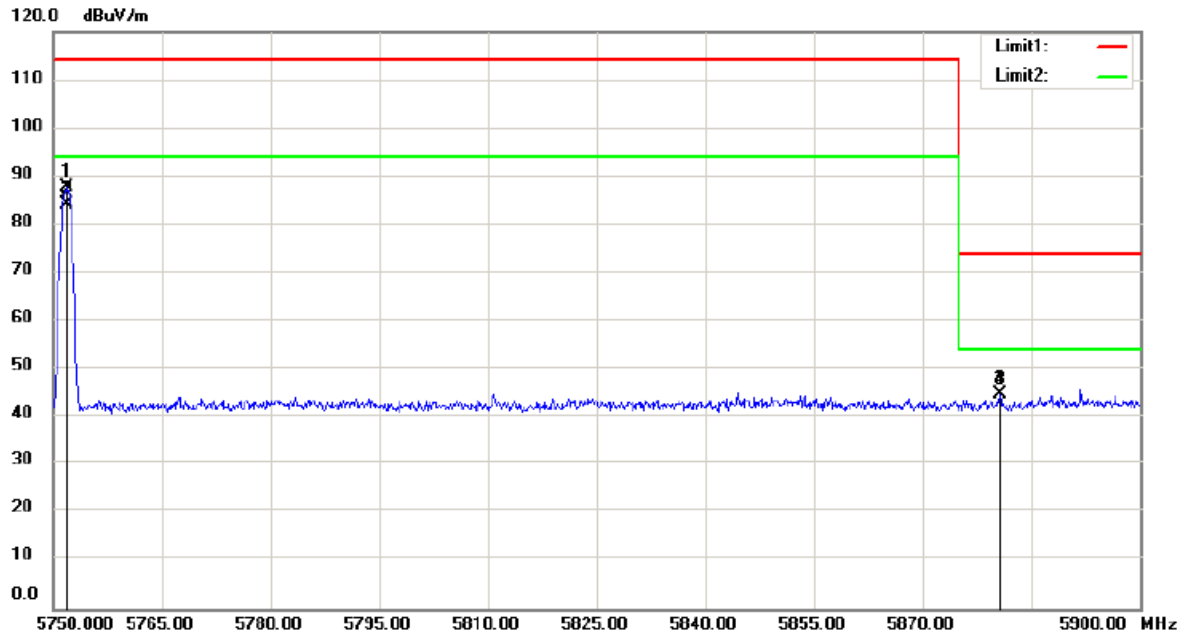

Site site #1 Polarization: **Horizontal** Temperature: 24 C
 Limit: (RE)FCC PART 5G(Band edge) Power: AC 120V/60Hz Humidity: 53 %
 Mode:ON
 Note:

No.	Mk.	Freq.	Reading Level	Correct Factor	Measurement	Limit	Over	Antenna Height	Table Degree	
		MHz	dBuV	dB	dBuV/m	dBuV/m	dB	cm	degree	Comment
1		5752.570	101.24	-13.63	87.61	114.00	-26.39			peak
2		5752.570	97.93	-13.63	84.30	94.00	-9.70			AVG
3		5880.650	58.13	-13.40	44.73	74.00	-29.27			peak
4	*	5880.650	58.13	-13.40	44.73	54.00	-9.27			AVG

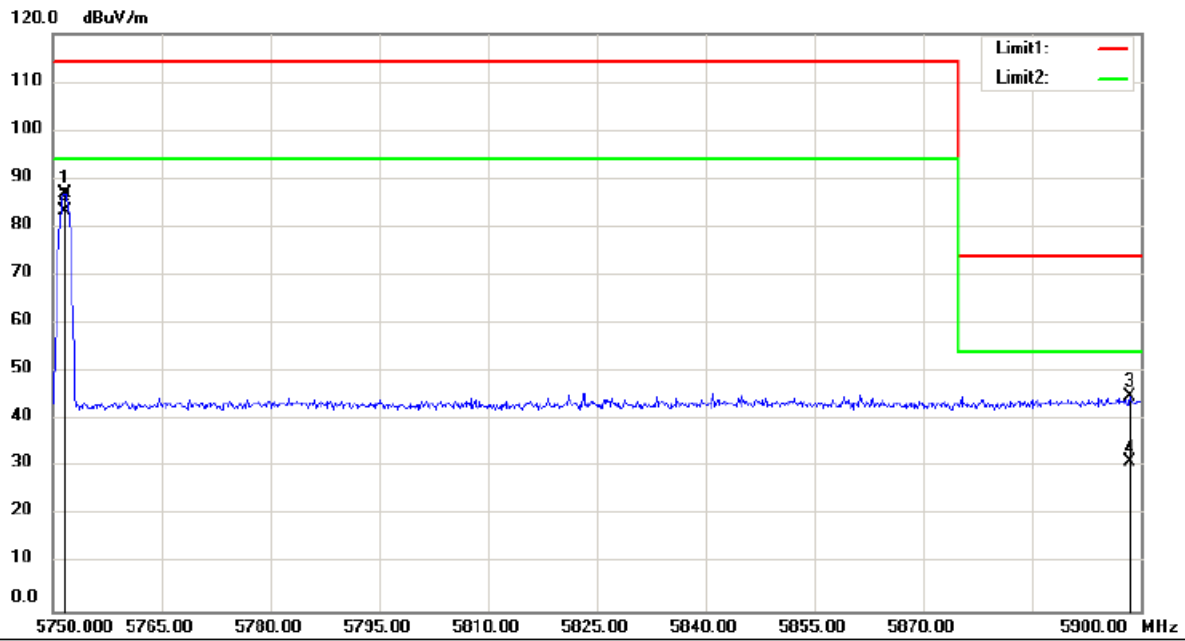

Site site #1 Polarization: **Vertical** Temperature: 24 C
 Limit: (RE)FCC PART 5G(Band edge) Power: AC 120V/60Hz Humidity: 53 %
 Mode:ON
 Note:

No.	Mk.	Freq.	Reading Level	Correct Factor	Measurement	Limit	Over	Antenna Height	Table Degree	
		MHz	dBuV	dB	dBuV/m	dBuV/m	dB	cm	degree	Comment
1		5752.570	100.43	-13.63	86.80	114.00	-27.20			peak
2	*	5752.570	96.83	-13.63	83.20	94.00	-10.80			AVG
3		5898.500	58.16	-13.36	44.80	74.00	-29.20			peak
4		5898.500	44.56	-13.36	31.20	54.00	-22.80			AVG

8. ANTENNA APPLICATION

8.1. Standard Applicable

According to §15.203, an intentional radiator shall be designed to ensure that no antenna other than that furnished by the responsible party shall be used with the device.

8.2. Antenna Construction

The EUT'S antenna is permanently integrated on the main EUT, no consideration of replacement.

---The End--