

2268T

2016*08*06

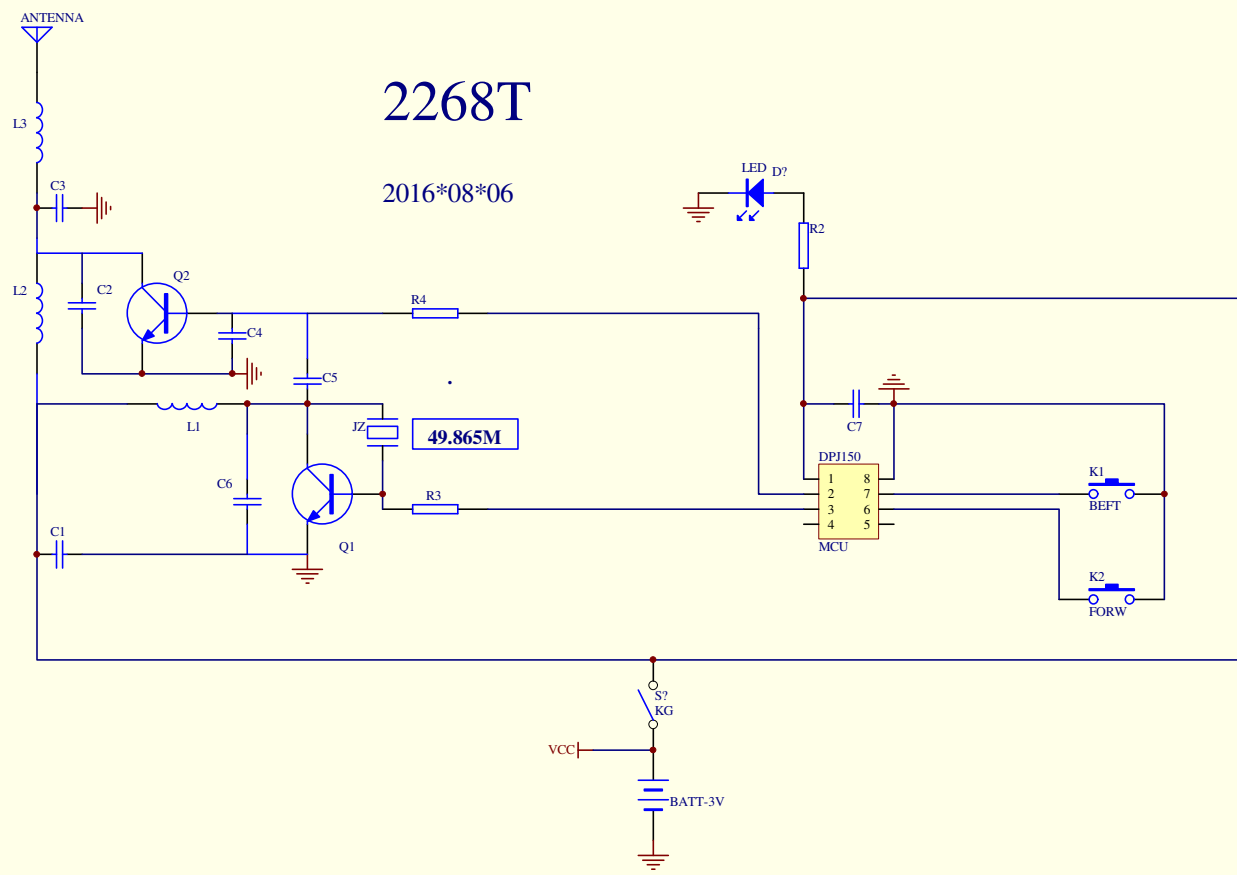

Robot launch board 49M

	Material name	Model specification	position	consumption
Patch	resistance	R-0603-10K-T	R4	1
		R-0603-300K-T	R3	1
		R-0603-1K-T	R2	1
	capacitance	C-0603-471P±5%-T	C4	1
		C-0603-15P±5%-T	C5	1
		C-0603-10P±5%-T	C3	1
		C-0603-104+80%-20%-T	C1, C6	2
	inductance	L-0805-2R2±10%-T	L1	1
		L-0805-5R6±10%-T	L2	1
	triode	Q-8050-SOT-23A (J3Y)-T	Q1	1
		Q-945-SOT-23A (L6)-T	Q2	1
	IC	【150】SOP8-T	MCU	1
plug-in unit	inductance	L-0410-3.3UH±10%	L3	1
	Crystal oscillator	49.865M	JZ	1
	Jumper	0.5*5MM	K1. K2	2
	LED	Red 3 red	LED	1
	Crystal oscillator	RT49.865M 【20PP】	JZ	1
	ANT	12-0.1-60MM 【white】	ANT	1
	Switch line	7-0.1-60MM 【blue】	K3. K4	2
	Power cathode	12-0.1-80MM 【gules】	VCC	1
	Power negative wire	12-0.1-80MM 【black】	GND	1
	Lamp holder	8MM		1
switch	SS12F47G9Switch gear (red handle)	SW	1	