

EMC

TEST REPORT

Report No. : 160800174TWN-001
Model No. : PFW18IMX6
Issued Date : Aug. 16, 2016

Applicant: Pulse Fitness Ltd.
Randor Park, Greenfield Road, Congleton, Cheshire,
ENGLAND, CW12 4TW

Test Method/ Standard: 47 CFR FCC Part 15.225

Test By: Intertek Testing Services Taiwan Ltd.,
Hsinchu Laboratory
No. 11, Lane 275, Ko-Nan 1 Street, Chia-Tung Li,
Shiang-Shan District, Hsinchu City, Taiwan

It may be duplicated completely for legal use with the allowance of the applicant. It shall not be reproduced except in full, without the written approval of Intertek Laboratory. The test result(s) in this report only applies to the tested sample(s).

The test report was prepared by:



Candy Liu/ Assistant

These measurements were taken by:

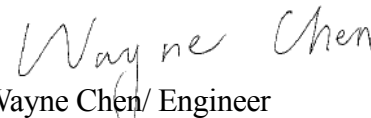

Wayne Chen/ Engineer

The test report was reviewed by:



Name Jimmy Yang

Title Senior Engineer



Revision History

Report No.	Issue Date	Revision Summary
160800174TWN-001	Apr. 16, 2016	Original report

Table of Contents

1. Summary of Test Data.....	4
2. General Information.....	5
3. Fundamental emission	7
4. 20 dB Bandwidth	9
5. Frequency Satiability	11
6. In band Radiated Emissions.....	19
7. Out of band Radiated Emissions.....	22
8. AC Power Line Conducted Emission	28
9. Antenna Requirement.....	32
Appendix A: Test equipment list.....	33
Appendix B: Measurement Uncertainty	35

1. Summary of Test Data

Test Requirement	Applicable Rule (Section 15.225)	Result
Fundamental emission	15.225 (a)	Pass
20 dB Bandwidth	15.215	Pass
Frequency Satiability	15.225 (e)	Pass
In band Radiated Emissions	15.225(b),15.225(c)	Pass
Out of band Radiated Emissions	15.225(d)	Pass
AC Power Line Conducted Emission	15.207	Pass
Antenna Requirement	15.203	Pass

2. General Information

2.1 Identification of the EUT

Product: Console for Exercise Machine
Model No: PFW18IMX6
FCC ID: 2AHD8PFW18IMX6
Operating Frequency: 13.56 MHz
Access scheme: ASK
Rated Power: DC 12 V from adapter
Power Cord: N/A
Sample Received: Jun. 02, 2016
Sample condition: Workable
Test Date(s): Jul. 15, 2016 ~ Jul. 20, 2016

Note 1: This report is for the exclusive use of Intertek's Client and is provided pursuant to the agreement between Intertek and its Client. Intertek's responsibility and liability are limited to the terms and conditions of the agreement. Intertek assumes no liability to any party, other than to the Client in accordance with the agreement, for any loss, expense or damage occasioned by the use of this report. Only the Client is authorized to permit copying or distribution of this report and then only in its entirety. Any use of the Intertek name or one of its marks for the sale or advertisement of the tested material, product or service must first be approved in writing by Intertek. The observations and test results in this report are relevant only to the sample tested. This report by itself does not imply that the material, product, or service is or has ever been under an Intertek certification program.

Note 2: When determining the test conclusion, the Measurement Uncertainty of test has been considered.

2.2 Description of EUT

The EUT transmit 13.56 MHz signal continuously while we power on the EUT.

Product OS version :	A1-R174
Product HW version :	MB:V1.02
Radio SW version :	version 5.90.195.89
Radio HW version :	WM-BAN-BM-04
Test Version :	A1-R175-WiFi-MFG-1606211502

For more detail features, please refer to user's Manual.

For more detail features, please refer to User's manual as file name "Installation guide.pdf"

2.3 Antenna description

The EUT uses a permanently connected antenna.

Antenna Type	: Loop Antenna
Connector Type	: Fixed

2.4 Operation mode

The EUT is supplied with DC 12 V from adapter (Test voltage: 120Vac, 60Hz).
The EUT transmit 13.56MHz continuously while we power on the EUT.

3. Fundamental emission

3.1 Operating environment

Temperature:	25	°C
Relative Humidity:	50	%
Atmospheric Pressure	1008	hPa
Requirement & Test method	15.225 (a)	

3.2 Limit for Fundamental emission

The field strength of any emissions within the band 13.553-13.567 MHz shall not exceed 15,848 uV/m(83.99 dBuV/m) at 30 meters.

3.3 Measuring instrument setting

Spectrum analyzer settings	
Spectrum Analyzer function	Setting
Detector	QP
RBW	10 kHz
Sweep	Auto couple
Trace	Max hold
Span	900 kHz
Attenuation	Auto

3.4 Test procedure

1. Configure the EUT according to ANSI C63.10. The EUT was placed on the top of the turntable 0.8 meter above ground. The center of the receiving antenna mounted on the top of a height-variable antenna tower was placed 3 meters far away from the turntable.
2. Power on the EUT and all the companion devices. The turntable was rotated by 360 degree to find the position of the maximum emission level.
3. The height of the receiving antenna was one meter above ground to find the maximum emission field strength of the both plane and coaxial polarity
4. Set the test-receiver system to peak or CISPR quasi-peak detector with specified bandwidth under maximum hold mode.

3.5 Test diagram

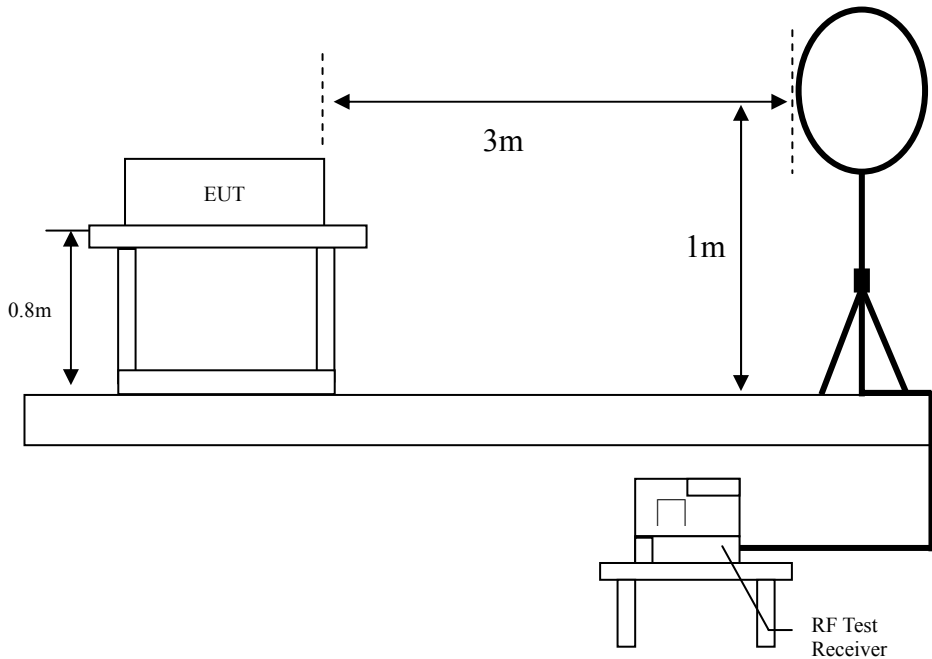

3.6 Test result

Polarity (circle)	Frequency (MHz)	Detection value	Factor (dB/m)	Reading (dBμV)	Value (dBμV/m)	Limit @ 3m (dBμV/m)	Tolerance (dB)
Plane	13.56	QP	22.27	36.26	58.53	124.00	-65.47
13.56MHz , Limit= 84dBuV +40 dB (decade) = 124 dB							

4. 20 dB Bandwidth

4.1 Operating environment

Temperature:	25	°C
Relative Humidity:	50	%
Atmospheric Pressure	1008	hPa
Requirement & Test method	15.215	

4.2 Limit for 20 dB bandwidth

None

4.3 Measuring instrument setting

Spectrum analyzer settings	
Spectrum Analyzer function	Setting
Detector	Peak
RBW	9kHz
VBW	$\geq 3 \times \text{RBW}$
Sweep	Auto couple
Trace	Allow the trace to stabilize.
Span	≥ 1.2 times the 20 dB bandwidth
Attenuation	Auto

4.4 Test procedure

The 20 dB bandwidth was measured by spectrum analyzer connected to a receive antenna placed near the test sample while it is transmitting.

4.5 Test results

Bandwidth	Frequency (MHz)	Bandwidth (kHz)
20dB	13.56	34.0

20dB Bandwidth

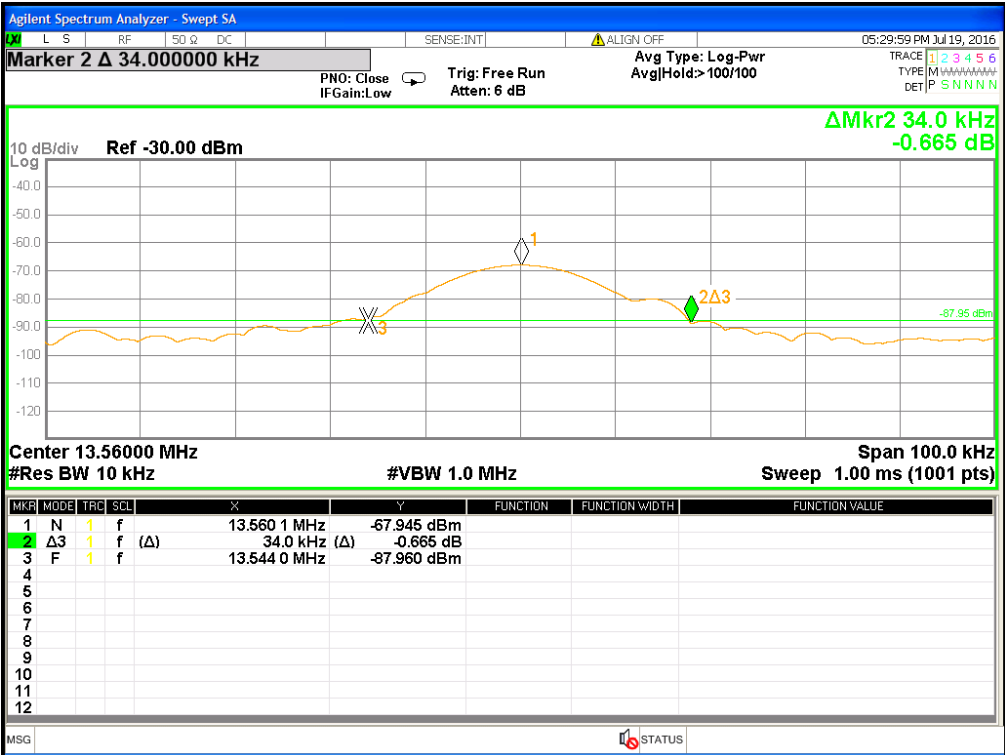

5. Frequency Satiability

5.1 Operating environment

Temperature:	25	°C
Relative Humidity:	55	%
Atmospheric Pressure	1008	hPa
Requirement & Test method	15.225(e)	

5.2 Limit for Frequency Satiability

The frequency tolerance of the carrier signal shall be maintained within $\pm 0.01\%$ of the operating frequency over a temperature variation of -20 degrees to $+50$ degrees C at normal supply voltage, and for a variation in the primary supply voltage from 85% to 115% of the rated supply voltage at a temperature of 20 degrees C.

5.3 Measuring instrument setting

Spectrum analyzer settings	
Spectrum Analyzer function	Setting
Detector	Peak
RBW	9kHz
VBW	$\geq 3 \times \text{RBW}$
Sweep	Auto couple
Trace	Allow the trace to stabilize.
Span	Sufficient to see the complete emission BW
Attenuation	Auto

5.4 Test procedure

Turn the EUT on, and couple its output to a frequency counter or other frequency-measuring device of sufficient accuracy, considering the frequency tolerance with which the EUT shall comply.

5.5 Test result

Temperature	Measuring frequency (MHz)	Voltage	Comparison frequency	Difference (MHz)	Difference (%)	Limit (%)	Result
-20	13.56	12Vdc	13.56	0.000100	0.000737%	±0.01	Pass
-10	13.56	12Vdc	13.56	0.000100	0.000737%	±0.01	Pass
0	13.56	12Vdc	13.56	0.000100	0.000737%	±0.01	Pass
10	13.56	12Vdc	13.56	0.000000	0.000000%	±0.01	Pass
20	13.56	12Vdc	13.56	0.000300	0.002212%	±0.01	Pass
30	13.56	12Vdc	13.56	0.000200	0.001475%	±0.01	Pass
40	13.56	12Vdc	13.56	0.000100	0.000737%	±0.01	Pass
50	13.56	12Vdc	13.56	0.000200	0.001475%	±0.01	Pass

Temperature	Measuring frequency (MHz)	Voltage	Comparison frequency	Difference (MHz)	Difference (%)	Limit (%)	Result
20	13.56	10.2Vdc	13.56	0.000200	0.001475%	±0.01	Pass
	13.56	12Vdc	13.56	0.000300	0.002212%	±0.01	Pass
	13.56	13.8Vdc	13.56	0.000200	0.001475%	±0.01	Pass

Frequency Satiability -20°C 12Vdc

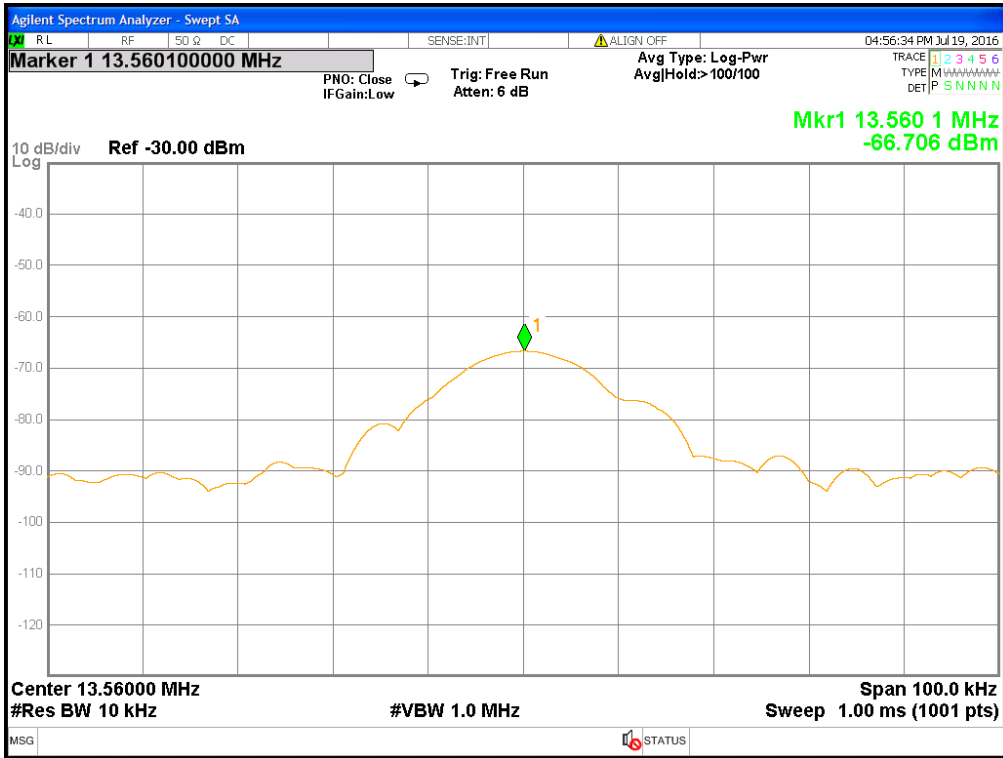

Frequency Satiability -10°C 12Vdc

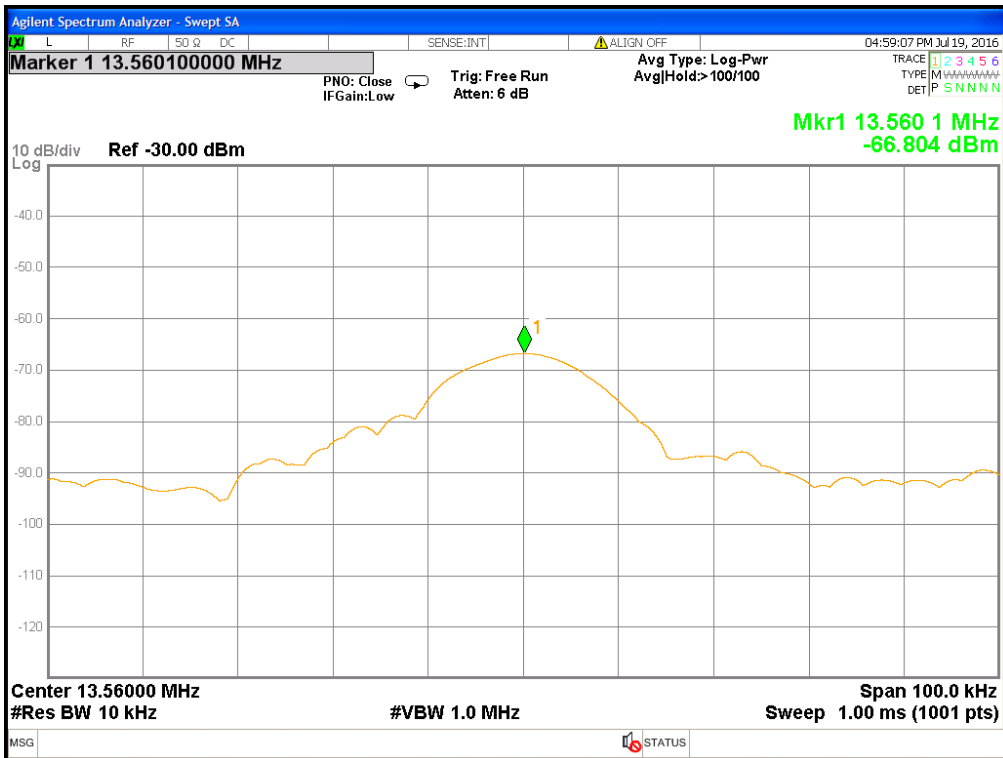

Frequency Satiability 0°C 12Vdc

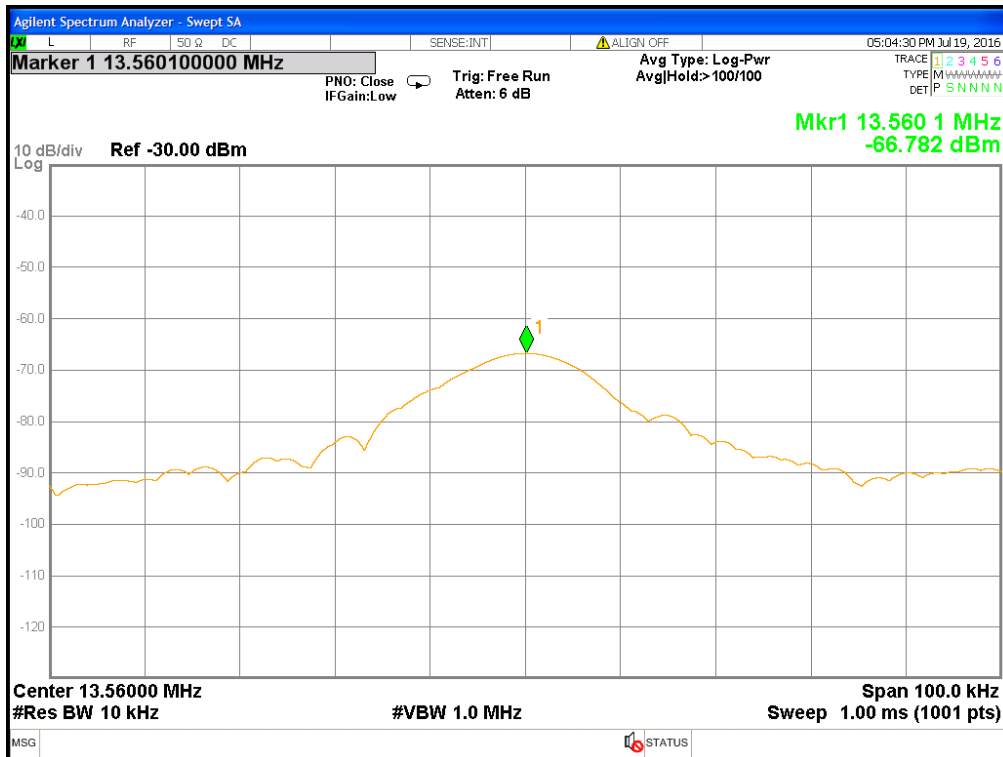

Frequency Satiability 10°C 12Vdc

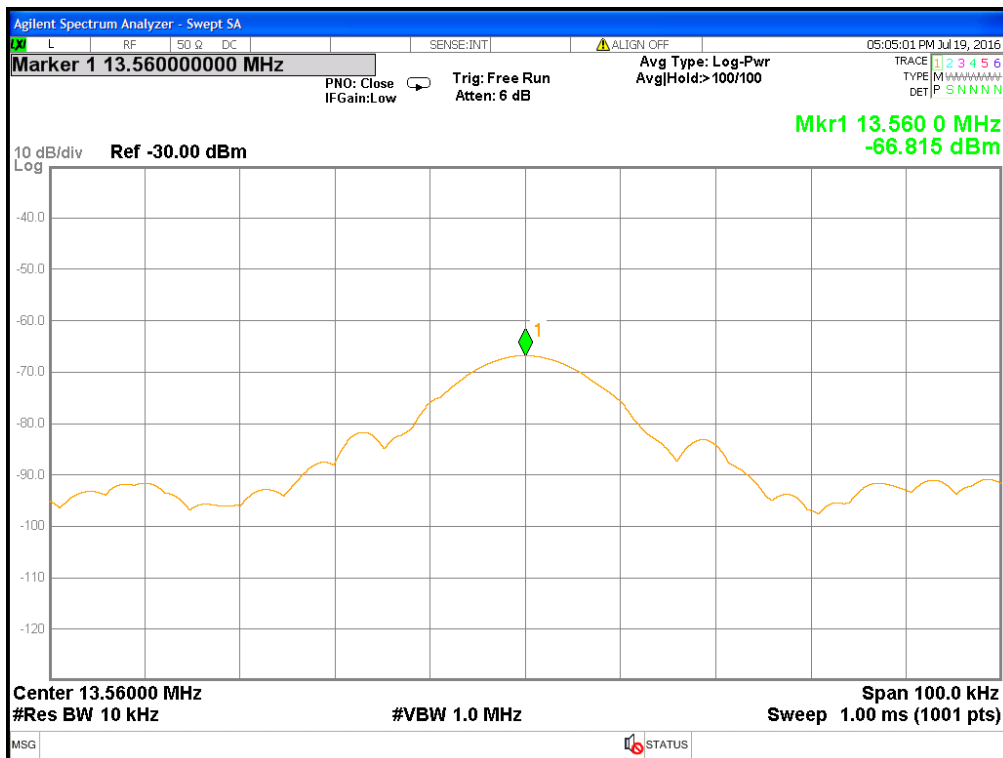

Frequency Satiability 20°C 12Vdc

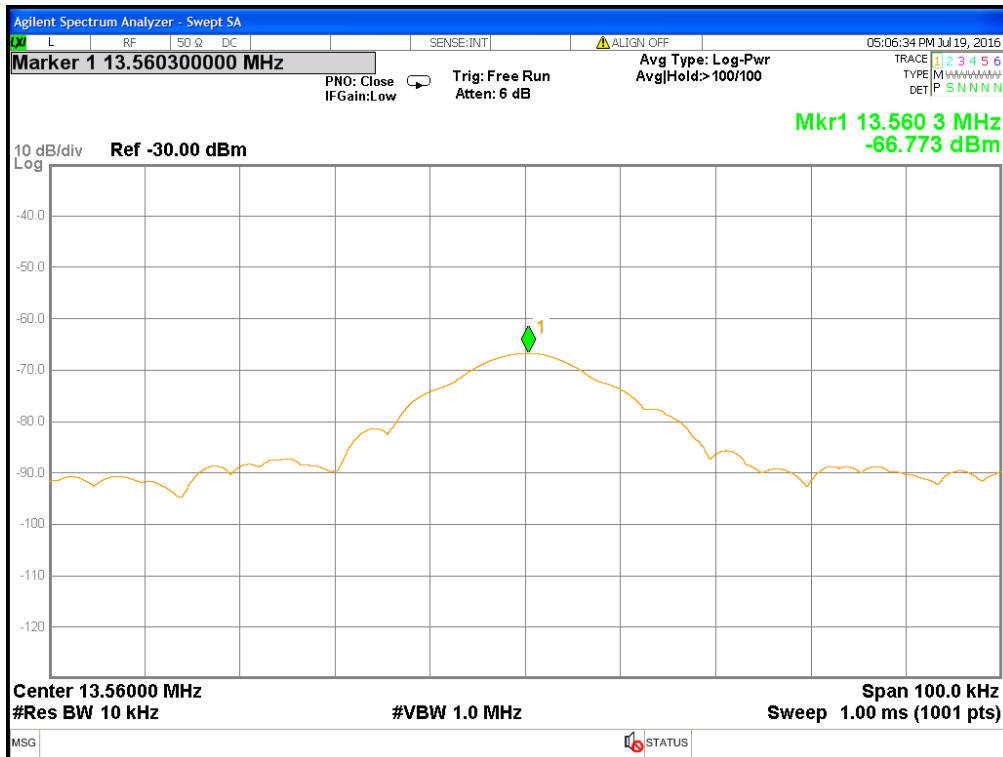

Frequency Satiability 30°C 12Vdc

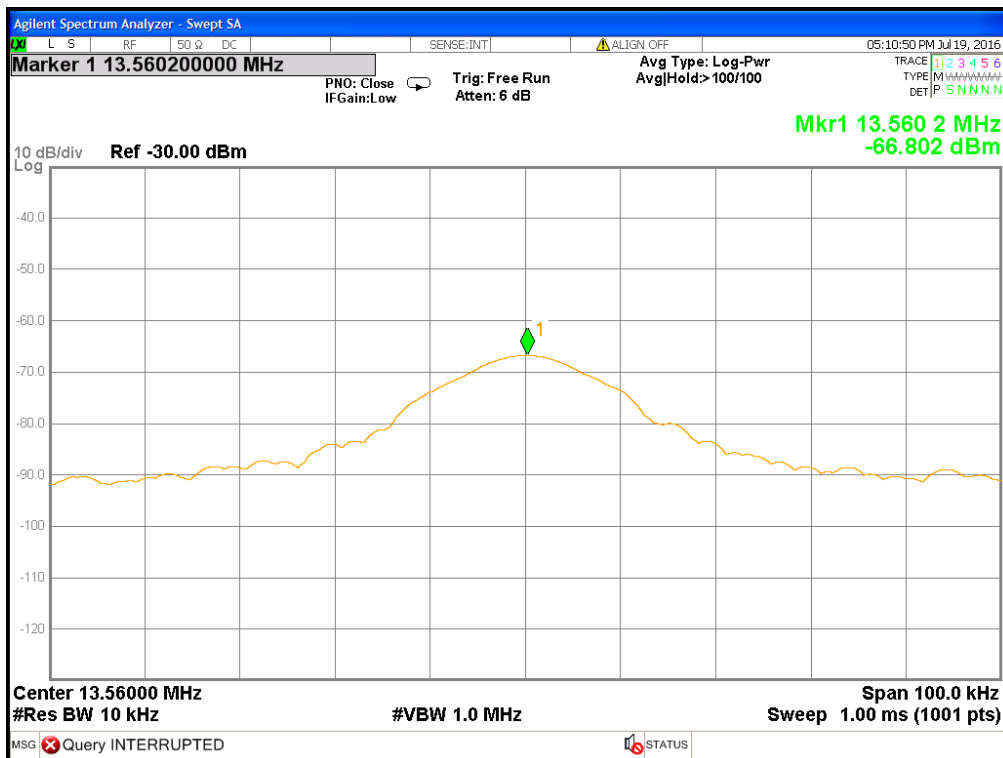

Frequency Satiability 20°C 12Vdc

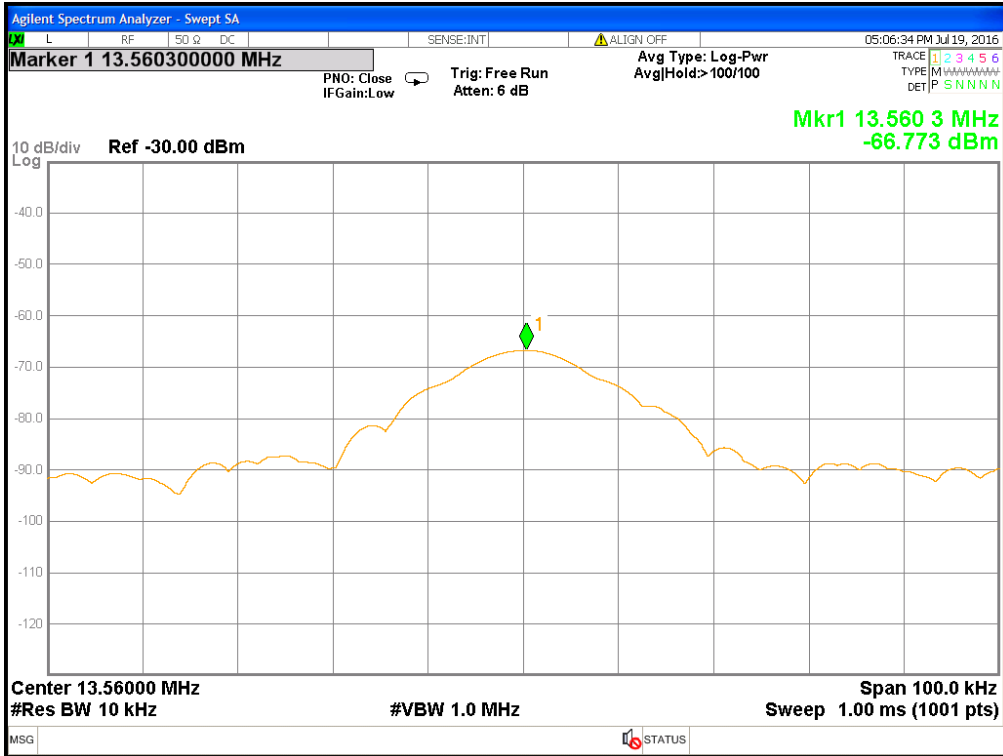

Frequency Satiability 20°C 10.2Vdc

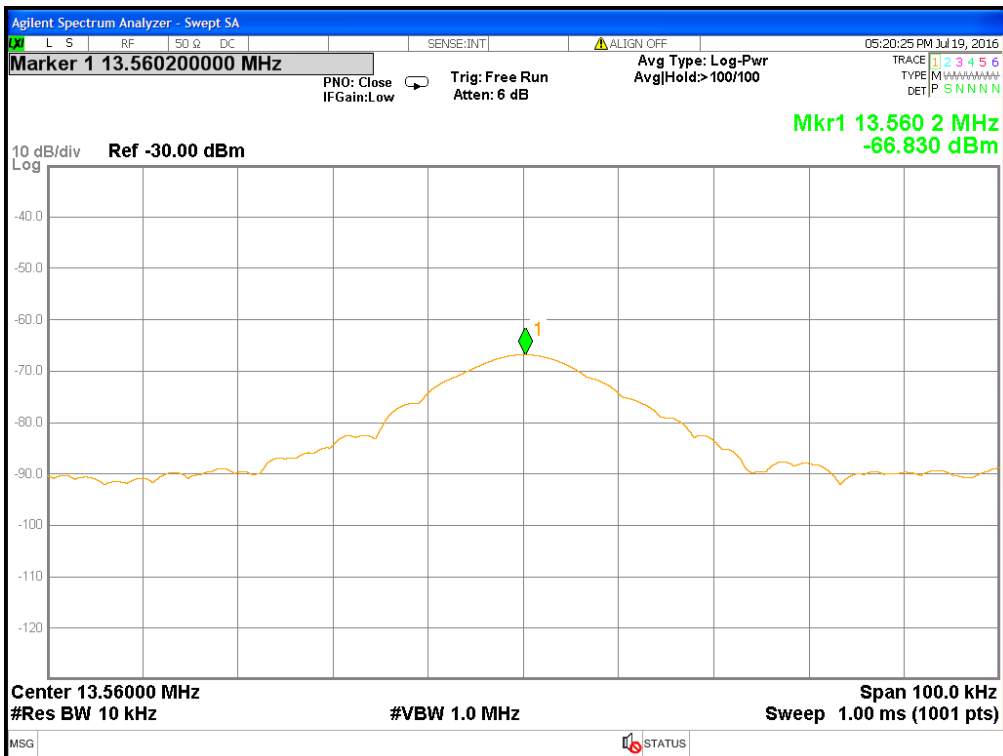

Frequency Satiability 20°C 13.8Vdc

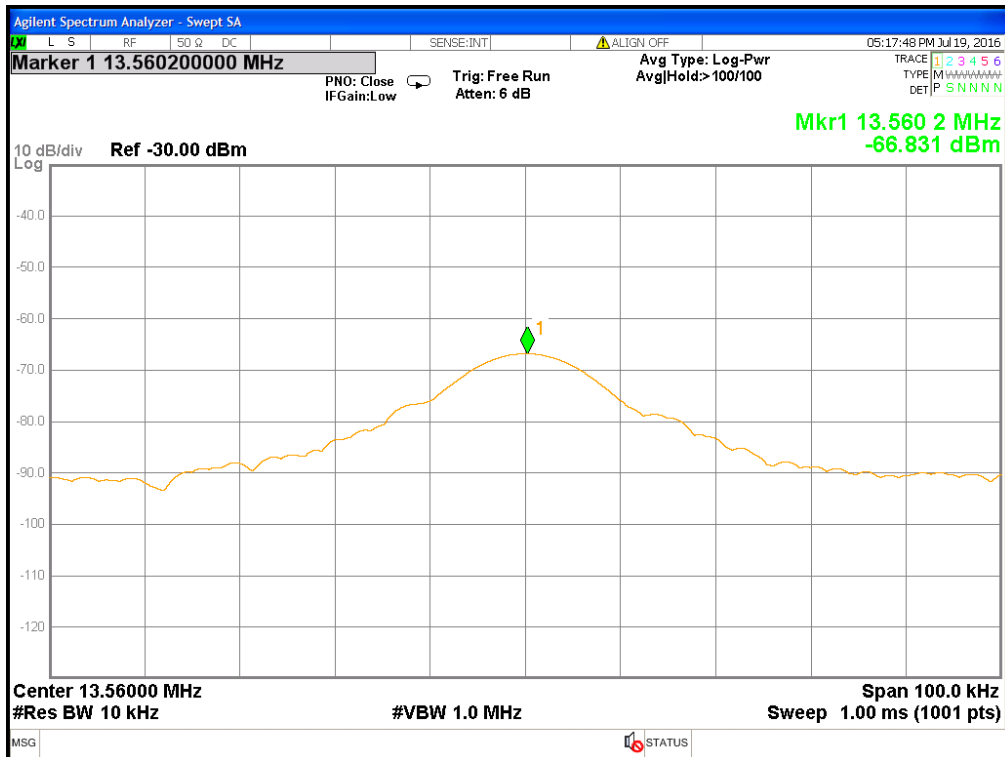

6. In band Radiated Emissions

6.1 Operating environment

Temperature:	25	°C
Relative Humidity:	50	%
Atmospheric Pressure	1008	hPa
Requirement	15.225(b),15.225(c)	

6.2 Limit for emissions in non-restricted frequency bands

Within the bands 13.410-13.553 MHz and 13.567-13.710 MHz, the field strength of any emissions shall not exceed 334 microvolts/meter at 30 meters.

Within the bands 13.110-13.410 MHz and 13.710-14.010 MHz the field strength of any emissions shall not exceed 106 microvolts/meter at 30 meters.

6.3 Measuring instruments setting

Spectrum analyzer settings	
Spectrum Analyzer function	Setting
Detector	QP
RBW	10 kHz
Sweep	Auto couple
Trace	Max hold
Span	900 kHz
Attenuation	Auto

6.4 Test procedure

1. Configure the EUT according to ANSI C63.10. The EUT was placed on the top of the turntable 0.8 meter above ground. The center of the receiving antenna mounted on the top of a height-variable antenna tower was placed 3 meters far away from the turntable.
2. Power on the EUT and all the companion devices. The turntable was rotated by 360 degree to find the position of the maximum emission level.
3. The height of the receiving antenna is one meter above ground to find the maximum emission field strength of the both plane and coaxial polarity
4. Set the test-receiver system to peak or CISPR quasi-peak detector with specified bandwidth under maximum hold mode.

6.5 Test diagram

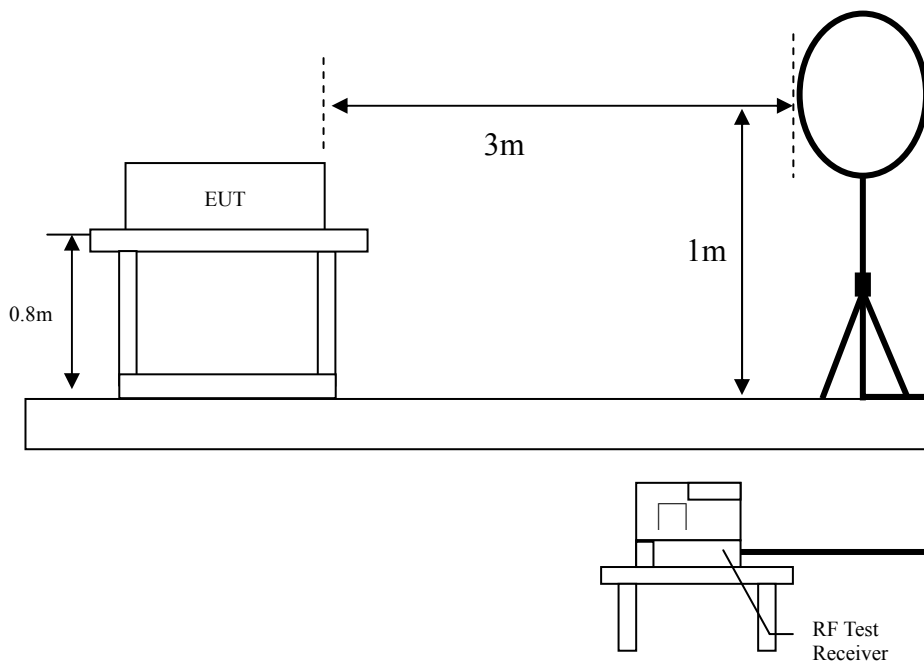

6.6 Test results

Worst case: Planar Polarity

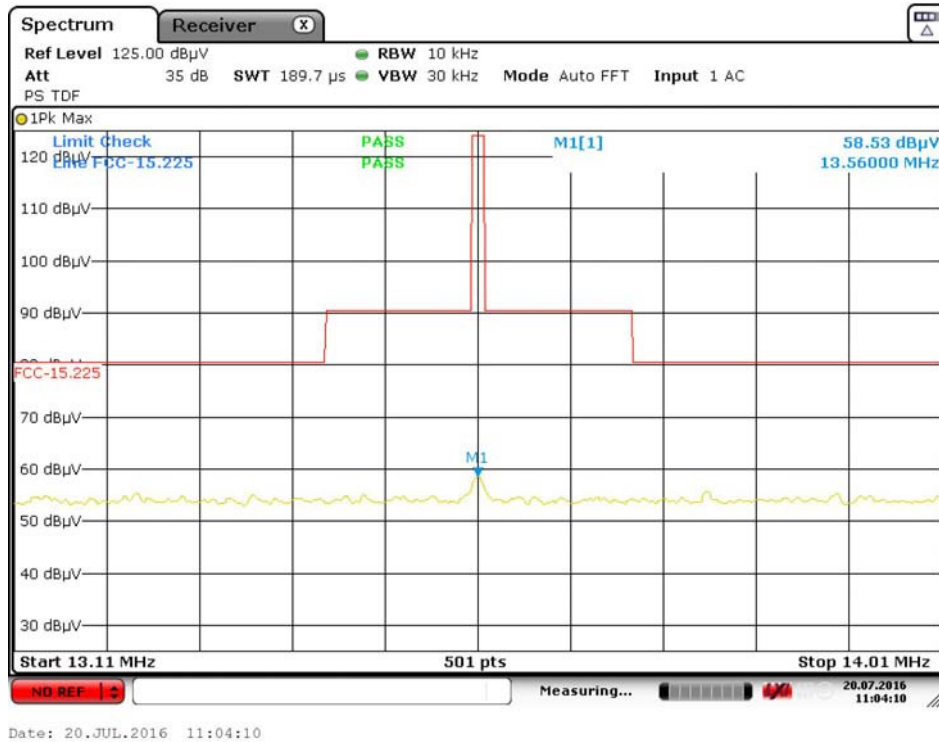

7. Out of band Radiated Emissions

7.1 Operating environment

Temperature:	25	°C
Relative Humidity:	55	%
Atmospheric Pressure	1008	hPa
Requirement	15.225(d), 15.205, 15.209	

7.2 Limit for emission in restricted frequency bands (Radiated emission measurement)

Frequency (MHz)	Field Strength (microvolts/meter)	Measurement distance (meters)
0.009~0.490	2400/F(kHz)	300
0.490~1.705	2400/F(kHz)	30
1.705~30	30	30
30-88	100	3
88-216	150	3
216-960	200	3
Above 960	500	3

Remark:

1. In the above table, the tighter limit applies at the band edges.
2. Distance refers to the distance in meters between the measuring instrument antenna and the closed point of any part of the device or system

7.3 Measuring instrument setting

Receiver settings	
Receiver function	Setting
Detector	QP
RBW	9-150 kHz ; 200-300 Hz 0.15-30 MHz; 9-10 kHz 30-1000 MHz; 100-120 kHz
VBW	$\geq 3 \times \text{RBW}$
Sweep	Auto couple
Attenuation	Auto

7.4 Test procedure

1. Configure the EUT according to ANSI C63.10. The EUT was placed on the top of the turntable 0.8 meter above ground. The center of the receiving antenna mounted on the top of a height-variable antenna tower was placed 3 meters far away from the turntable.
2. Power on the EUT and all the companion devices. The turntable was rotated by 360 degree to find the position of the maximum emission level.
3. The height of the receiving antenna was varied between one meter and four meters above ground to find the maximum emission field strength of the both horizontal and vertical polarization
4. If find the frequencies above the limit or below within 3dB, the antenna tower was scan (from 1m to 4m) and then the turntable was rotated to find the maximum reading.
5. Set the test-receiver system to peak or CISPR quasi-peak detector with specified bandwidth under maximum hold mode.
6. If the emissions level of the EUT in peak mode was 3dB lower than the average limit specified then testing will be stopped and peak values of the EUT will be reported. Otherwise, the emissions which do not have 3dB margin will be measured using the quasi-peak method for below 1GHz.
7. In case the emission is lower than 30MHz, loop antenna has to be used for measurement and the recorded data should be quasi-peak measured by receiver.

7.5 Test configuration

7.5.1 Radiated emission from 9kHz to 30MHz uses Loop Antenna:

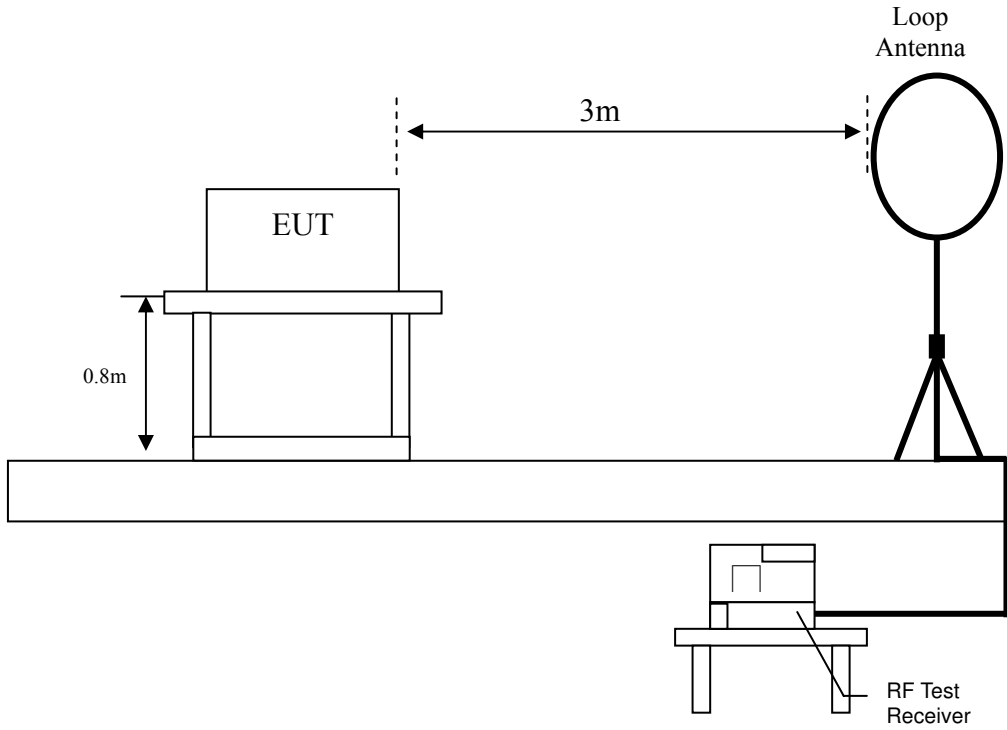

7.5.2 Radiated emission below 1GHz using Bilog Antenna

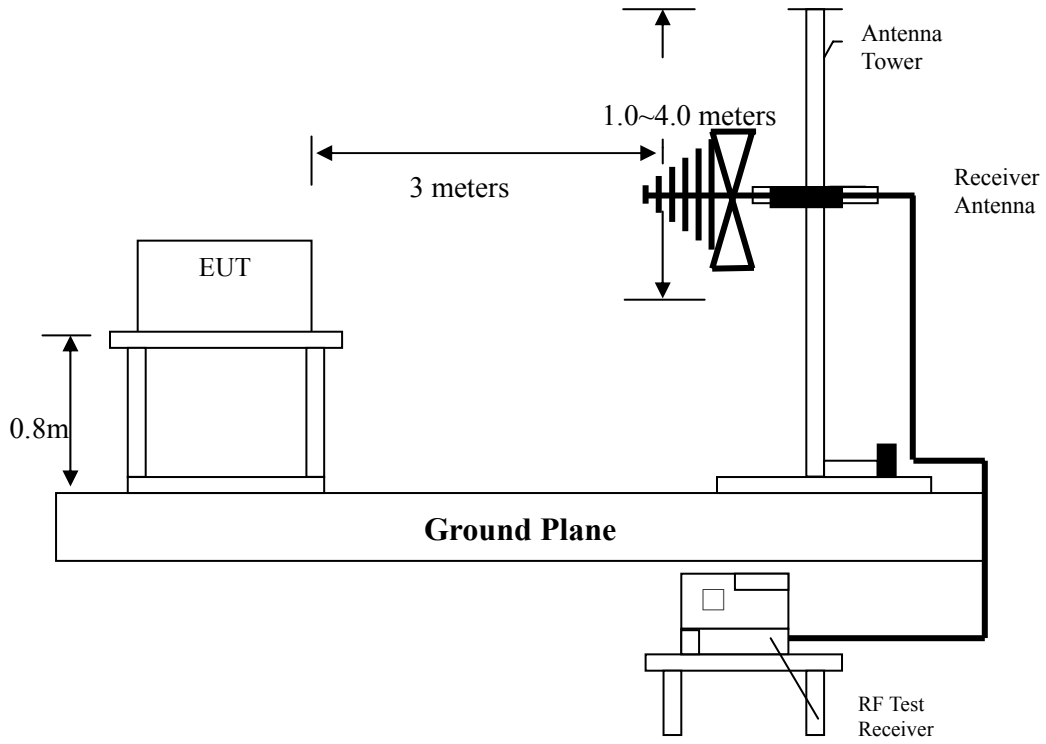

7.6 Test result

7.6.1 Measurement results: frequencies 9 kHz- 30 MHz

The test was performed on EUT under continuously transmitting mode.

EUT : PFW18IMX6

Polarity (circle)	Freq. (MHz)	Detection value	factor (dB/m)	Reading (dBμV)	value (dBμV/m)	Limit @ 3m (dBμV/m)	Tolerance (dB)
Plane	0.02	QP	20.92	33.58	54.49	121.58	-67.09
Plane	0.03	QP	20.86	40.98	61.84	118.06	-56.22
Plane	0.04	QP	20.85	29.66	50.50	115.56	-65.06
Plane	0.06	QP	20.82	31.23	52.05	112.04	-59.99
Plane	0.15	QP	20.77	29.52	50.29	104.08	-53.79

Remark: 1. Corr. Factor = Antenna Factor + Cable Loss

2. Corrected Level = Reading + Corr. Factor

3. Limit@3m = Limit@300m + 80dB, Limit@3m = Limit@30m + 40dB

Note: The amplitude of spurious emissions that are attenuated by more than 20dB below the permissible value has no need to be reported.

7.6.2 Measurement results: frequencies 30 MHz- 1 GHz

The test was performed on EUT under continuously transmitting mode.

EUT : PFW18IMX6

Antenna Polariz. (V/H)	Freq. (MHz)	Detection value	factor (dB/m)	Reading (dBµV)	value (dBµV/m)	Limit @ 3m (dBµV/m)	Tolerance (dB)
V	35.94	QP	15.89	19.10	34.99	40.00	-5.01
V	39.72	QP	16.30	15.87	32.17	40.00	-7.83
V	47.82	QP	16.99	12.00	28.99	40.00	-11.01
V	71.58	QP	14.03	13.38	27.41	40.00	-12.59
V	84.00	QP	11.63	18.00	29.63	40.00	-10.37
V	135.60	QP	15.53	8.73	24.26	43.50	-19.24
H	68.88	QP	14.55	14.10	28.65	40.00	-11.35
H	84.00	QP	11.63	19.82	31.45	40.00	-8.55
H	95.88	QP	11.04	15.54	26.58	43.50	-16.92
H	107.76	QP	12.71	12.85	25.56	43.50	-17.94
H	135.60	QP	15.53	6.42	21.95	43.50	-21.55
H	214.68	QP	14.64	17.23	31.87	43.50	-11.63

Remark: 1. Corr. Factor = Antenna Factor + Cable Loss

2. Corrected Level = Reading + Corr. Factor

Note: The amplitude of spurious emissions that are attenuated by more than 20dB below the permissible value has no need to be reported.

8. AC Power Line Conducted Emission

8.1 Operating environment

Temperature:	27	°C
Relative Humidity:	52	%
Atmospheric Pressure	1009	hPa
Requirement	15.207	

8.2 Limit for AC power line conducted emission

Freq. (MHz)	Conducted Limit (dBuV)	
	Q.P.	Ave.
0.15~0.50	66 – 56*	56 – 46*
0.50~5.00	56	46
5.00~30.0	60	50

8.3 Measuring instrument setting

Receiver settings	
Receiver function	Setting
Detector	QP
Start frequency	0.15MHz
Stop frequency	30MHz
IF bandwidth	9 kHz
Attenuation	10dB

8.4 Test procedure

1. Configure the EUT according to ANSI C63.10. The EUT or host of EHT has to be placed 0.4 meter far from the conducting wall of the shielding room and at least 80 centimeters from any other grounded conducting surface.
2. Connect EUT or host of EUT to the power mains through a line impedance stabilization network.
3. All the companion devices are connected to the other LISN. The LISN should provide 50U_h/50ohms coupling impedance.
4. The frequency range from 150 kHz to 30MHz was searched
5. Set the test-receiver system to peak detector and specified bandwidth with maximum hold mode.
6. The measurement has to be done between each power line and ground at the power terminal.

8.5 Test diagram

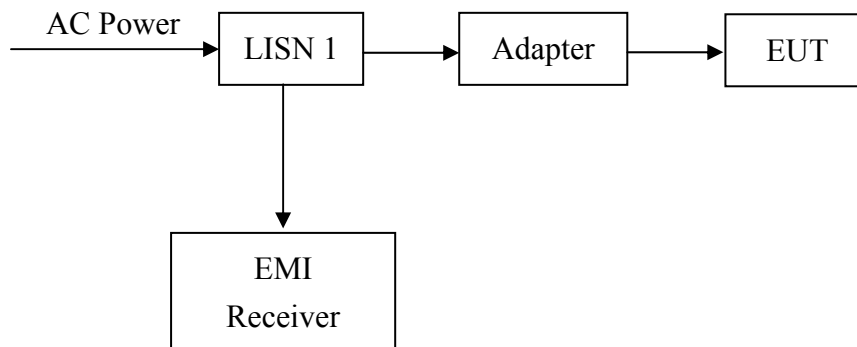

8.6 Test results

Phase : Live Line
 EUT : PFW18IMX6
 Test Condition : Normal communication

Frequency (MHz)	Corr. Factor (dB)	Level Qp (dBuV)	Limit Qp (dBuV)	Level Av (dBuV)	Limit Av (dBuV)	Margin (dB)	
						Qp	Av
0.158	9.74	56.09	65.56	42.76	55.56	-9.47	-12.80
0.212	9.74	47.15	63.14	30.64	53.14	-15.99	-22.50
0.502	9.78	41.18	56.00	25.34	46.00	-14.82	-20.66
0.862	9.80	41.56	56.00	29.28	46.00	-14.44	-16.72
7.175	9.96	39.22	60.00	32.27	50.00	-20.78	-17.73
21.600	10.03	37.45	60.00	28.95	50.00	-22.55	-21.05

Remark:

1. Corr. Factor (dB) = LISN Factor (dB) + Cable Loss (dB)
2. Margin (dB) = Level (dBuV) – Limit (dBuV)

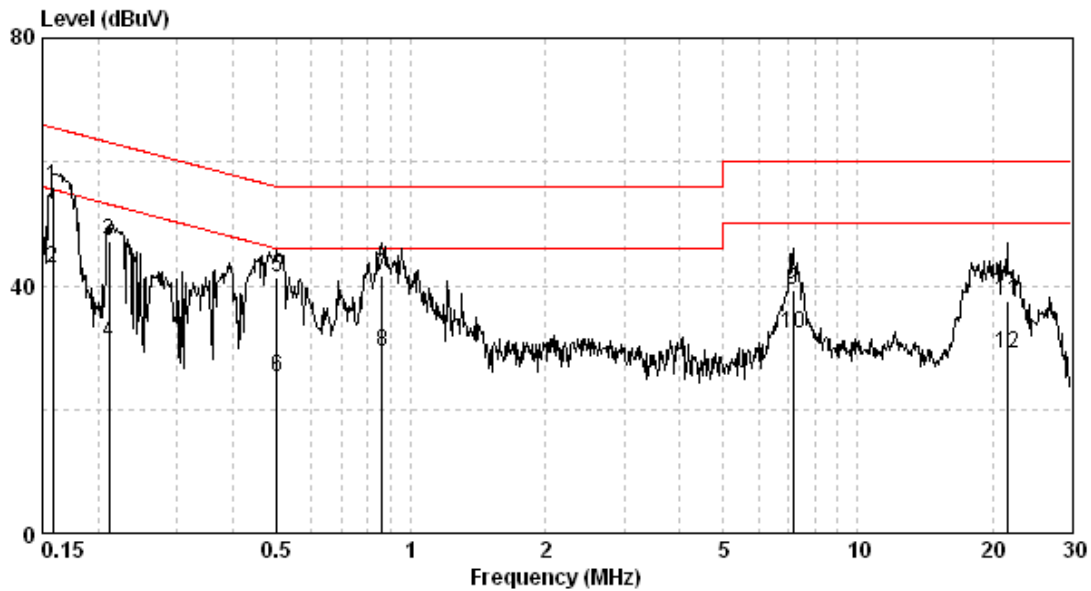

Phase : Neutral Line
EUT : PFW18IMX6
Test Condition : Normal communication

Frequency (MHz)	Corr. Factor (dB)	Level Qp (dBuV)	Limit Qp (dBuV)	Level Av (dBuV)	Limit Av (dBuV)	Margin (dB)	
						Qp	Av
0.161	9.74	55.62	65.43	30.39	55.43	-9.81	-25.04
0.214	9.74	35.57	63.05	33.71	53.05	-27.48	-19.34
0.835	9.83	35.90	56.00	25.11	46.00	-20.10	-20.89
0.880	9.84	37.65	56.00	30.14	46.00	-18.35	-15.86
7.252	9.98	38.79	60.00	31.61	50.00	-21.21	-18.39
22.063	10.10	37.98	60.00	26.33	50.00	-22.02	-23.67

Remark:

1. Corr. Factor (dB) = LISN Factor (dB) + Cable Loss (dB)
2. Margin (dB) = Level (dBuV) – Limit (dBuV)

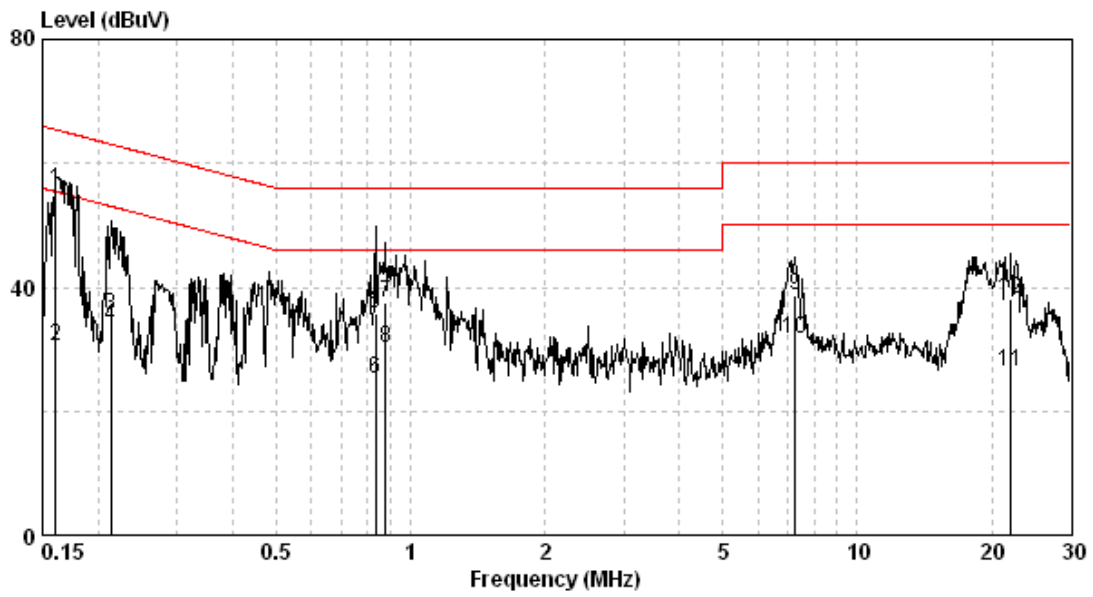

9. Antenna Requirement

9.1 Limit for Antenna Requirement

An intentional radiator shall be designed to ensure that no antenna other than that furnished by the responsible party shall be used with the device. The use of a permanently attached antenna or of an antenna that uses a unique coupling to the intentional radiator shall be considered sufficient to comply with the provisions of this section. The manufacturer may design the unit so that a broken antenna can be replaced by the user, but the use of a standard antenna jack or electrical connector is prohibited. This requirement does not apply to carrier current devices or to devices operated under the provisions of §15.211, §15.213, §15.217, §15.219, or §15.221. Further, this requirement does not apply to intentional radiators that must be professionally installed, such as perimeter protection systems and some field disturbance sensors, or to other intentional radiators which, in accordance with §15.31(d), must be measured at the installation site. However, the installer shall be responsible for ensuring that the proper antenna is employed so that the limits in this part are not exceeded.

9.2 Test results

The sample tested met the antenna requirement. The antenna was a Loop Antenna attached to the circuit board by a Specific cable.

Appendix A: Test equipment list

Equipment	Brand	Model No.	Serial No.	Calibration Date	Next Calibration Date
ESCI EMI Test Receiver	Rohde & Schwarz	ESCI	100018	2015/12/02	2016/11/30
Spectrum Analyzer	Rohde & Schwarz	FSP30	100137	2015/08/18	2016/08/16
Broadband Antenna	SHWARZBECK	VULB 9168	9168-172	2013/08/08	2016/08/06
Signal Analyzer	Agilent	N9030A	MY51380492	2015/09/21	2016/09/19
966-2(A) Cable 9kHz~26.5GHz	SUHNER	SMA / EX 100	N/A	2016/05/05	2017/05/04
966-2(B) Cable 9kHz~26.5GHz	SUHNER	SUCOFLEX 104P	CB0005	2016/05/04	2017/05/03
RF Cable 9kHz~26.5GHz	SUHNER	SUCOFLEX 102	CB0006	2016/05/05	2017/05/04
966-2_3m Semi-Anechoic Chamber	966_2	CEM-966_2	N/A	2016/02/24	2017/02/22
Active Loop Antenna	SCHWARZBECK MESS-ELEKTRO NIC	FMZB1519	1519-067	2016/03/03	2017/03/02
Attenuator	PASTERNAK	N/A	PA7001-20	2016/05/06	2017/05/05
Attenuator	EMCI	N/A	AT-N0619	2016/05/06	2017/05/05

Equipment	Brand	Model No.	Serial No.	Calibration Date	Next Calibration Date
EMI Test Receiver	Rohde & Schwarz	ESR-7	101232	2015/12/02	2016/11/30
Test software	ADT	Radiated test system	7.5.14	NCR	NCR
EMI Receiver	R&S	ESCI	100059	2015/11/03	2016/11/01
Two-Line V-Network	R&S	ENV216	101159	2016/06/02	2017/06/01
LISN	SCHAFFNER	MN2050D	1586	2016/05/25	2017/05/24
CON-1 Shielded Room	N/A	N/A	N/A	NCR	NCR
CON-1 Cable	SUHNER	BNC / RG-58	1521946	2016/05/07	2017/05/06
Test software	Audix	e3	4.2004-1-12k	NCR	NCR

Note: No Calibration Required (NCR).

Appendix B: Measurement Uncertainty

This uncertainty represents an expanded uncertainty expressed at approximately the 95 % confidence level using a coverage factor of $k=2$.

Item	Uncertainty
Vertically polarized radiated disturbances from 30MHz~1GHz in a semi-anechoic chamber at a distance of 3m	5.14 dB
Horizontally polarized radiated disturbances from 30MHz~1GHz in a semi-anechoic chamber at a distance of 3m	5.22 dB
Vertically polarized Radiated disturbances from 1GHz~18GHz in a semi-anechoic chamber at a distance of 3m	3.64 dB
Horizontally polarized Radiated disturbances from 1GHz~18GHz in a semi-anechoic chamber at a distance of 3m	3.64 dB
Vertically polarized Radiated disturbances from 18GHz~40GHz in a semi-anechoic chamber at a distance of 3m	2.7 dB
Horizontally polarized Radiated disturbances from 18GHz~40GHz in a semi-anechoic chamber at a distance of 3m	2.7 dB
Conducted Output power	0.42 dB
Radiated electromagnetic disturbances in the frequency range from 9kHz to 30MHz	3.53 dB
Conducted disturbance measurements at a mains port from 9 kHz to 30 MHz using a 50 Ω /50 μ H +5 Ω artificial mains network (AMN)	2.47 dB