

FCC PART 15.247

TEST REPORT

For

ZEROTECH (Beijing) Intelligence Technology Co., Ltd.

Floor 2-203 Building No.9, Zhongguancun Software Park, Haidian District, Beijing, China 100193

FCC ID: 2AHCT105404202000

| | |
|---|----------------------------------|
| Report Type: Original Report | Product Type: ZEROTIME |
| Test Engineer: Allen Qiao | <i>Allen Qiao</i> |
| Report Number: RBJ160118052-00B | |
| Report Date: 2016-03-04 | |
| Reviewed By: Sula Huang RF Leader | <i>Sula Huang</i> |
| Test Laboratory: Bay Area Compliance Laboratories Corp. (Dongguan) No.69 Pulongcun, Puxinhu Industrial Zone, Tangxia, Dongguan, Guangdong, China Tel: +86-769-86858888 Fax: +86-769-86858891 www.baclcorp.com.cn | |

Note: This test report is prepared for the customer shown above and for the device described herein. It may not be duplicated or used in part without prior written consent from Bay Area Compliance Laboratories Corp. (Dongguan).

TABLE OF CONTENTS

| | |
|---|-----------|
| GENERAL INFORMATION..... | 4 |
| PRODUCT DESCRIPTION FOR EQUIPMENT UNDER TEST (EUT) | 4 |
| OBJECTIVE | 4 |
| RELATED SUBMITTAL(S)/GRANT(S)..... | 4 |
| TEST METHODOLOGY | 4 |
| TEST FACILITY | 4 |
| SYSTEM TEST CONFIGURATION..... | 5 |
| DESCRIPTION OF TEST CONFIGURATION | 5 |
| EUT EXERCISE SOFTWARE | 5 |
| EQUIPMENT MODIFICATIONS | 5 |
| BLOCK DIAGRAM OF TEST SETUP | 5 |
| SUMMARY OF TEST RESULTS | 6 |
| FCC §15.247 (i) & §1.1307 & §2.1091- MAXIMUM PERMISSIBLE EXPOSURE (MPE)..... | 7 |
| APPLICABLE STANDARD | 7 |
| FCC §15.203 - ANTENNA REQUIREMENT..... | 8 |
| APPLICABLE STANDARD | 8 |
| ANTENNA CONNECTOR CONSTRUCTION | 8 |
| FCC §15.207 (a) – AC LINE CONDUCTED EMISSIONS | 9 |
| APPLICABLE STANDARD | 9 |
| MEASUREMENT UNCERTAINTY..... | 9 |
| EUT SETUP | 9 |
| EMI TEST RECEIVER SETUP..... | 10 |
| TEST PROCEDURE | 10 |
| CORRECTED AMPLITUDE & MARGIN CALCULATION | 10 |
| TEST EQUIPMENT LIST AND DETAILS..... | 11 |
| TEST RESULTS SUMMARY | 11 |
| TEST DATA | 11 |
| FCC §15.209, §15.205 & §15.247(d) - SPURIOUS EMISSIONS..... | 14 |
| APPLICABLE STANDARD | 14 |
| MEASUREMENT UNCERTAINTY | 14 |
| EUT SETUP | 14 |
| EMI TEST RECEIVER & SPECTRUM ANALYZER SETUP | 15 |
| TEST PROCEDURE | 15 |
| CORRECTED AMPLITUDE & MARGIN CALCULATION | 15 |
| TEST EQUIPMENT LIST AND DETAILS..... | 16 |
| TEST RESULTS SUMMARY | 16 |
| TEST DATA | 16 |
| FCC §15.247(a) (2) – 6dB BANDWIDTH..... | 21 |
| APPLICABLE STANDARD | 21 |
| TEST PROCEDURE | 21 |
| TEST EQUIPMENT LIST AND DETAILS..... | 21 |
| TEST DATA | 21 |
| FCC §15.247(b) (3) - MAXIMUM PEAK CONDUCTED OUTPUT POWER..... | 26 |

APPLICABLE STANDARD26
TEST PROCEDURE26
TEST EQUIPMENT LIST AND DETAILS.....26
TEST DATA26

FCC §15.247(d) – 100 kHz BANDWIDTH OF FREQUENCY BAND EDGE.....28

APPLICABLE STANDARD28
TEST PROCEDURE28
TEST EQUIPMENT LIST AND DETAILS.....28
TEST DATA28

FCC §15.247(e) - POWER SPECTRAL DENSITY31

APPLICABLE STANDARD31
TEST PROCEDURE31
TEST EQUIPMENT LIST AND DETAILS.....31
TEST DATA31



GENERAL INFORMATION

Product Description for Equipment under Test (EUT)

The *ZEROTECH (Beijing) Intelligence Technology Co., Ltd.*'s product, model number: *ZT3024G (FCC ID: 2AHCT105404202000)* (the "EUT") in this report is named *ZEROTIME*, which was measured approximately: 8.6 cm (L) x 5.6 cm (W) x 2.3 cm (H), rated input voltage: DC 8-12 V.

** All measurement and test data in this report was gathered from production sample serial number: 160118052. (Assigned by BACL.Dongguan). The EUT was received on 2016-01-20.*

Objective

This report is prepared on behalf of *ZEROTECH (Beijing) Intelligence Technology Co., Ltd.* in accordance with Part 2, Subpart J, Part 15, Subparts A, B and C of the Federal Communications Commission's rules.

The tests were performed in order to determine the compliance of the EUT with FCC Part 15-Subpart C, section 15.203, 15.205, 15.207, 15.209 and 15.247 rules.

Related Submittal(s)/Grant(s)

Submitted with the part of a system with FCC ID: 2AHCT105404201000.

Test Methodology

All measurements contained in this report were conducted with ANSI C63.10-2013, American National Standard of Procedures for Compliance Testing of Unlicensed Wireless Devices.

All emissions measurement was performed and Bay Area Compliance Laboratories Corp. (Dongguan).

Test Facility

The Test site used by Bay Area Compliance Laboratories Corp. (Dongguan) to collect test data is located on the No.69 Pulongcun, Puxinhu Industrial Zone, Tangxia, Dongguan, Guangdong, China

Test site at Bay Area Compliance Laboratories Corp. (Dongguan) has been fully described in reports submitted to the Federal Communications Commission (FCC). The details of these reports have been found to be in compliance with the requirements of Section 2.948 of the FCC Rules on February 06, 2015.

The Federal Communications Commission has the reports on file and is listed under FCC Registration No.: 273710. The test site has been approved by the FCC for public use and is listed in the FCC Public Access Link (PAL) database.

SYSTEM TEST CONFIGURATION

Description of Test Configuration

The system was configured for testing in Engineering Mode, which was provided by the manufacturer.

For 2.4G band, 8 channels are provided to testing:

| Channel | Frequency (MHz) | Channel | Frequency (MHz) |
|---------|-----------------|---------|-----------------|
| 0 | 2406 | 4 | 2446 |
| 1 | 2416 | 5 | 2456 |
| 2 | 2426 | 6 | 2466 |
| 3 | 2436 | 7 | 2476 |

3 channels were tested: 2406MHz, 2436MHz and 2476MHz.

The device support MIMO mode only, SISO mode can't support by this device.

EUT Exercise Software

The software "Xsheel.exe" was used for testing, which was provided by manufacturer. The maximum power with duty cycle 100% was configured by system default setting.

Equipment Modifications

No modification was made to the EUT.

Block Diagram of Test Setup

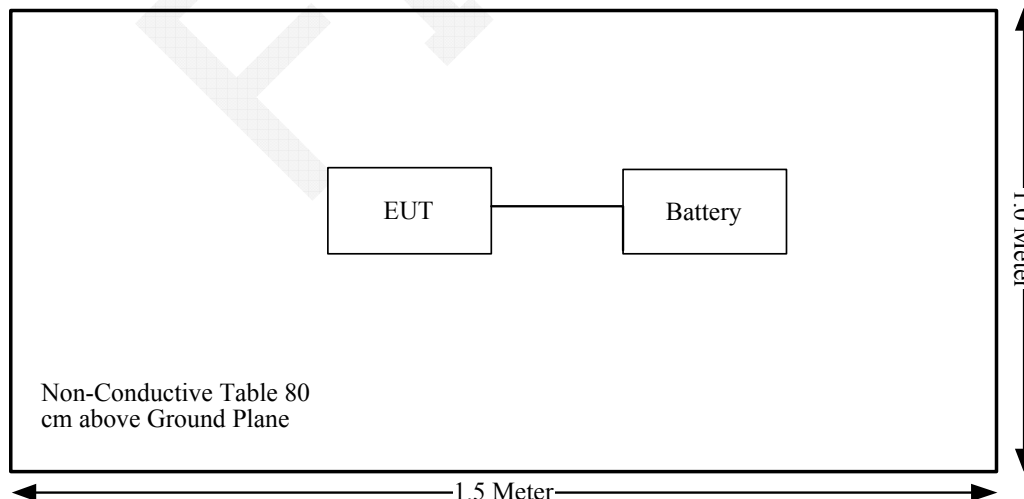

SUMMARY OF TEST RESULTS

| FCC Rules | Description of Test | Result |
|--------------------------------|--|---------------|
| §15.247 (i), §1.1307 & §2.1091 | Maximum Permissible Exposure (MPE) | Compliance |
| §15.203 | Antenna Requirement | Compliance |
| §15.207 (a) | AC Line Conducted Emissions | Compliance |
| §15.247(d) | Spurious Emissions at Antenna Port | Compliance |
| §15.205, §15.209, §15.247(d) | Spurious Emissions | Compliance |
| §15.247 (a)(2) | 6 dB Bandwidth | Compliance |
| §15.247(b)(3) | Maximum Peak Conducted Output Power | Compliance |
| §15.247(d) | 100 kHz Bandwidth of Frequency Band Edge | Compliance |
| §15.247(e) | Power Spectral Density | Compliance |

FCC §15.247 (i) & §1.1307 & §2.1091- MAXIMUM PERMISSIBLE EXPOSURE (MPE)

Applicable Standard

According to subpart 15.247(i) and subpart §1.1307, systems operating under the provisions of this section shall be operated in a manner that ensures that the public is not exposed to radio frequency energy level in excess of the Commission’s guidelines.

Limits for Maximum Permissible Exposure (MPE) (§1.1310, §2.1091)

| (B) Limits for General Population/Uncontrolled Exposure | | | | |
|---|-------------------------------|-------------------------------|-------------------------------------|--------------------------|
| Frequency Range (MHz) | Electric Field Strength (V/m) | Magnetic Field Strength (A/m) | Power Density (mW/cm ²) | Averaging Time (minutes) |
| 0.3–1.34 | 614 | 1.63 | *(100) | 30 |
| 1.34–30 | 824/f | 2.19/f | *(180/f ²) | 30 |
| 30–300 | 27.5 | 0.073 | 0.2 | 30 |
| 300–1500 | / | / | f/1500 | 30 |
| 1500–100,000 | / | / | 1.0 | 30 |

f = frequency in MHz; * = Plane-wave equivalent power density;

According to §1.1310 and §2.1091 RF exposure is calculated.

Calculated Formulary:

Predication of MPE limit at a given distance

$S = PG/4\pi R^2$ = power density (in appropriate units, e.g. mW/cm²);

P = power input to the antenna (in appropriate units, e.g., mW);

G = power gain of the antenna in the direction of interest relative to an isotropic radiator, the power gain factor, is normally numeric gain;

R = distance to the center of radiation of the antenna (appropriate units, e.g., cm);

Calculated Data:

| Frequency (MHz) | Antenna Gain | | Maximum Power | | Evaluation Distance (cm) | Power Density (mW/cm ²) | MPE Limit (mW/cm ²) |
|-----------------|--------------|-----------|---------------|--------|--------------------------|-------------------------------------|---------------------------------|
| | (dBi) | (numeric) | (dBm) | (mW) | | | |
| 2406-2476 | 5.7 | 3.72 | 21 | 125.89 | 20 | 0.093 | 1 |

Note: The tune-up power is 20dBm+/-1dB, that was declared by manufacturer.

Result: The device meet FCC MPE at 20 cm distance

FCC §15.203 - ANTENNA REQUIREMENT

Applicable Standard

According to § 15.203, an intentional radiator shall be designed to ensure that no antenna other than that furnished by the responsible party shall be used with the device. The use of a permanently attached antenna or of an antenna that uses a unique coupling to the intentional radiator shall be considered sufficient to comply with the provisions of this section. The manufacturer may design the unit so that a broken antenna can be replaced by the user, but the user of a standard antenna jack or electrical connector is prohibited. The structure and application of the EUT were analyzed to determine compliance with section §15.203 of the rules. §15.203 state that the subject device must meet the following criteria:

- a. Antenna must be permanently attached to the unit.
- b. Antenna must use a unique type of connector to attach to the EUT.
- c. Unit must be professionally installed, and installer shall be responsible for verifying that the correct antenna is employed with the unit.

Antenna Connector Construction

The EUT has 2 antennas arrangement use a unique type of connector to attach to the EUT, and the antenna gain is 5.7dBi, fulfill the requirement of the item. Please refer to the internal photos.

Result: Compliance.

FCC §15.207 (a) – AC LINE CONDUCTED EMISSIONS

Applicable Standard

FCC§15.207

Measurement Uncertainty

Compliance or non-compliance with a disturbance limit shall be determined in the following manner

FEMVA

The setup of EUT is according with per ANSI C63.10-2013 measurement procedure. The specification used was with the FCC Part 15.207 limits.

The spacing between the peripherals was 10 cm.

The adapter was connected to a 120 VAC/60 Hz power source

EMI Test Receiver Setup

The EMI test receiver was set to investigate the spectrum from 150 kHz to 30 MHz.

During the conducted emission test, the EMI test receiver was set with the following configurations:

| Frequency Range | IF B/W |
|------------------|--------|
| 150 kHz – 30 MHz | 9 kHz |

Test Procedure

During the conducted emission test, the adapter was connected to the first LISN.

Maximizing procedure was performed on the six (6) highest emissions of the EUT.

All data was recorded in the Quasi-peak and average detection mode.

Corrected Amplitude & Margin Calculation

The basic equation is as follows:

$$V_C = V_R + A_C + VDF$$

$$C_f = A_C + VDF$$

Herein,

V_C (cord. Reading): corrected voltage amplitude

V_R : reading voltage amplitude

A_C : attenuation caused by cable loss

VDF: voltage division factor of AMN

C_f : Correction Factor

The “**Margin**” column of the following data tables indicates the degree of compliance within the applicable limit. For example, a margin of 7dB means the emission is 7dB below the maximum limit. The equation for margin calculation is as follows:

$$\text{Margin} = \text{Limit} - \text{Corrected Amplitude}$$

Test Equipment List and Details

| Manufacturer | Description | Model | Serial Number | Calibration Date | Calibration Due Date |
|--------------|--------------------|---------|---------------|------------------|----------------------|
| R&S | EMI Test Receiver | ESCS 30 | 830245/006 | 2015-12-10 | 2016-12-09 |
| R&S | L.I.S.N | ESH2-Z5 | 892107/021 | 2015-07-16 | 2016-07-15 |
| R&S | Two-line V-network | ENV 216 | 3560.6550.12 | 2015-11-26 | 2016-11-25 |
| N/A | Coaxial Cable | 1.8m | N/A | 2015-05-06 | 2016-05-06 |
| R&S | Test Software | EMC32 | Version8.53.0 | N/A | N/A |

* **Statement of Traceability:** Bay Area Compliance Laboratories Corp. (Dongguan) attests that all calibrations have been performed, traceable to National Primary Standards and International System of Units (SI).

Test Results Summary

According to the recorded data in following table, the EUT complied with the FCC Part 15.207, with the worst margin reading of:

7.9 dB at 0.703777 MHz in the Neutral conducted mode .

Test Data

Environmental Conditions

| | |
|---------------------------|-----------|
| Temperature: | 22.8 °C |
| Relative Humidity: | 42% |
| ATM Pressure: | 101.6 kPa |

The testing was performed by Allen Qiao on 2016-03-03.

Test Mode: Transmitting

AC120 V, 60 Hz, Line:

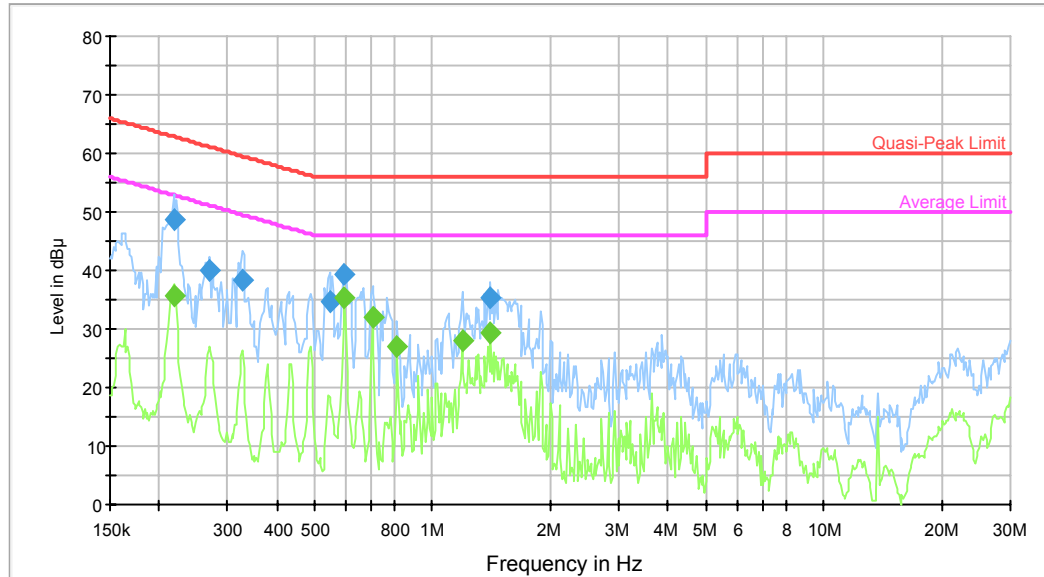

| Frequency (MHz) | QuasiPeak (dBμV) | Bandwidth (kHz) | Line | Corr. (dB) | Margin (dB) | Limit (dBμV) | Comment |
|-----------------|------------------|-----------------|------|------------|-------------|--------------|------------|
| 0.218141 | 48.7 | 9.000 | L1 | 9.7 | 14.2 | 62.9 | Compliance |
| 0.270502 | 40.1 | 9.000 | L1 | 9.7 | 21.0 | 61.1 | Compliance |
| 0.327509 | 38.3 | 9.000 | L1 | 9.7 | 21.2 | 59.5 | Compliance |
| 0.545378 | 34.8 | 9.000 | L1 | 9.8 | 21.2 | 56.0 | Compliance |
| 0.595338 | 39.3 | 9.000 | L1 | 9.8 | 16.7 | 56.0 | Compliance |
| 1.407671 | 35.3 | 9.000 | L1 | 9.8 | 20.7 | 56.0 | Compliance |

| Frequency (MHz) | Average (dBμV) | Bandwidth (kHz) | Line | Corr. (dB) | Margin (dB) | Limit (dBμV) | Comment |
|-----------------|----------------|-----------------|------|------------|-------------|--------------|------------|
| 0.218141 | 35.8 | 9.000 | L1 | 9.7 | 17.1 | 52.9 | Compliance |
| 0.595338 | 35.4 | 9.000 | L1 | 9.8 | 10.6 | 46.0 | Compliance |
| 0.703777 | 32.0 | 9.000 | L1 | 9.8 | 14.0 | 46.0 | Compliance |
| 0.812315 | 26.8 | 9.000 | L1 | 9.8 | 19.2 | 46.0 | Compliance |
| 1.190776 | 28.1 | 9.000 | L1 | 9.8 | 17.9 | 46.0 | Compliance |
| 1.407671 | 29.3 | 9.000 | L1 | 9.8 | 16.7 | 46.0 | Compliance |

AC120 V, 60 Hz, Neutral:

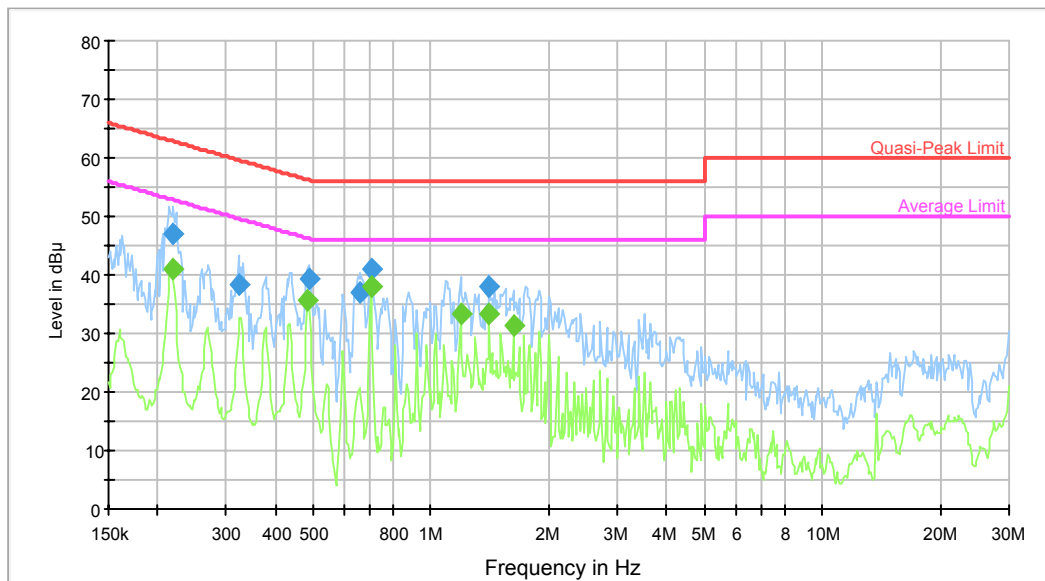

| Frequency (MHz) | QuasiPeak (dB μ V) | Bandwidth (kHz) | Line | Corr. (dB) | Margin (dB) | Limit (dB μ V) | Comment |
|-----------------|------------------------|-----------------|------|------------|-------------|--------------------|------------|
| 0.219886 | 47.0 | 9.000 | N | 9.7 | 15.8 | 62.8 | Compliance |
| 0.322331 | 38.1 | 9.000 | N | 9.7 | 21.5 | 59.6 | Compliance |
| 0.487810 | 39.2 | 9.000 | N | 9.7 | 17.0 | 56.2 | Compliance |
| 0.660314 | 37.0 | 9.000 | N | 9.7 | 19.0 | 56.0 | Compliance |
| 0.703777 | 41.0 | 9.000 | N | 9.7 | 15.0 | 56.0 | Compliance |
| 1.407671 | 37.9 | 9.000 | N | 9.8 | 18.1 | 56.0 | Compliance |

| Frequency (MHz) | Average (dB μ V) | Bandwidth (kHz) | Line | Corr. (dB) | Margin (dB) | Limit (dB μ V) | Comment |
|-----------------|----------------------|-----------------|------|------------|-------------|--------------------|------------|
| 0.218141 | 40.8 | 9.000 | N | 9.7 | 12.1 | 52.9 | Compliance |
| 0.483938 | 35.7 | 9.000 | N | 9.7 | 10.6 | 46.3 | Compliance |
| 0.703777 | 38.1 | 9.000 | N | 9.7 | 7.9 | 46.0 | Compliance |
| 1.190776 | 33.3 | 9.000 | N | 9.8 | 12.7 | 46.0 | Compliance |
| 1.407671 | 33.5 | 9.000 | N | 9.8 | 12.5 | 46.0 | Compliance |
| 1.624765 | 31.2 | 9.000 | N | 9.8 | 14.8 | 46.0 | Compliance |

FCC §15.209, §15.205 & §15.247(d) - SPURIOUS EMISSIONS

Applicable Standard

FCC §15.247 (d); §15.209; §15.205;

Measurement Uncertainty

Compliance or non-compliance with a disturbance limit shall be determined in the following manner

FEMVA

Above 1GHz:

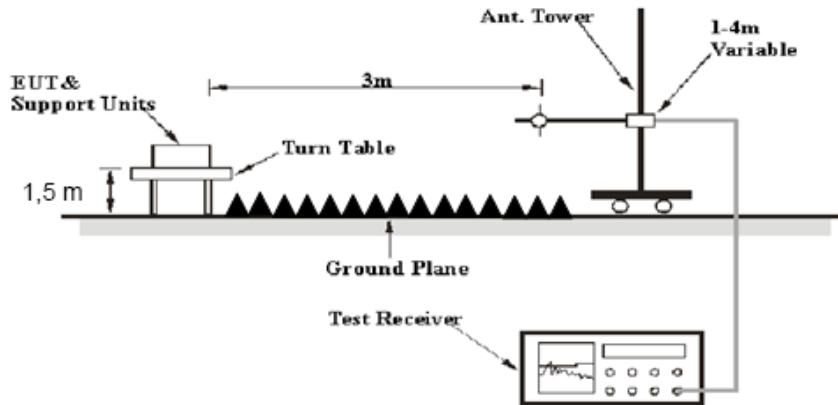

The radiated emission tests were performed in the 3 meters chamber test site, using the setup accordance with the ANSI C63.10-2013. The specification used was the FCC 15.209, and FCC 15.247 limits.

The spacing between the peripherals was 10 cm.

EMI Test Receiver & Spectrum Analyzer Setup

The system was investigated from 30 MHz to 25 GHz.

During the radiated emission test, the EMI test receiver & Spectrum Analyzer Setup were set with the following configurations:

| Frequency Range | RBW | Video B/W | IF B/W | Detector |
|------------------|---------|-----------|--------|----------|
| 30MHz – 1000 MHz | 120 kHz | 300 kHz | 120kHz | QP |
| Above 1 GHz | 1MHz | 3 MHz | / | PK |
| | 1MHz | 10 Hz | / | Ave. |

Test Procedure

Maximizing procedure was performed on the highest emissions to ensure that the EUT complied with all installation combinations.

Data was recorded in Quasi-peak detection mode for frequency range of 30 MHz-1 GHz, peak and Average detection modes for frequencies above 1 GHz.

Corrected Amplitude & Margin Calculation

The Corrected Amplitude is calculated by adding the Antenna Loss and Cable Loss, and subtracting the Amplifier Gain from the Meter Reading. The basic equation is as follows:

$$\text{Corrected Amplitude} = \text{Meter Reading} + \text{Antenna Loss} + \text{Cable Loss} - \text{Amplifier Gain}$$

The “**Margin**” column of the following data tables indicates the degree of compliance with the applicable limit. For example, a margin of 7dB means the emission is 7dB below the limit. The equation for margin calculation is as follows:

$$\text{Margin} = \text{Limit} - \text{Corrected Amplitude}$$

Test Equipment List and Details

| Manufacturer | Description | Model | Serial Number | Calibration Date | Calibration Due Date |
|-----------------------|-------------------|---------------------|--------------------|------------------|----------------------|
| R&S | EMI Test Receiver | ESCI | 100224 | 2015-08-03 | 2016-08-02 |
| Sunol Sciences | Antenna | JB3 | A060611-3 | 2014-11-06 | 2017-11-05 |
| HP | Amplifier | 8447E | 2434A02181 | 2015-09-01 | 2016-09-01 |
| Agilent | Spectrum Analyzer | E4440A | SG43360054 | 2015-11-23 | 2016-11-22 |
| ETS-Lindgren | Horn Antenna | 3115 | 9808-5557 | 2015-09-06 | 2018-09-06 |
| Mini-Circuit | Amplifier | ZVA-213-S+ | 054201245 | 2016-02-19 | 2017-02-19 |
| R&S | Spectrum Analyzer | FSP 38 | 100478 | 2015-11-23 | 2016-11-22 |
| Ducommun Technologies | Horn Antenna | ARH-4223-02 | 1007726-01 1304 | 2014-06-16 | 2017-06-15 |
| Quinstar | Amplifier | QLW- 18405536-JO | 15964001001 | 2015-09-06 | 2016-09-06 |
| N/A | Coaxial Cable | 14m | N/A | 2015-05-06 | 2016-05-06 |
| N/A | Coaxial Cable | 8m | N/A | 2015-05-06 | 2016-05-06 |
| N/A | Coaxial Cable | 0.1m | N/A | 2015-05-06 | 2016-05-06 |
| E-Microwave | DC Blocking | EMDCB-00036 | 0E01201047 | 2015-05-06 | 2016-05-06 |

* **Statement of Traceability:** Bay Area Compliance Laboratories Corp. (Dongguan) attests that all calibrations have been performed, traceable to National Primary Standards and International System of Units (SI).

Test Results Summary

According to the recorded data in following table, the EUT complied with the FCC Title 47, Part 15, Section 15.205, 15.209 and 15.247, with the worst margin reading of:

1.05 dB at 2483.5 MHz in the Vertical polarization

Test Data

Environmental Conditions

| | |
|---------------------------|-----------|
| Temperature: | 21.5°C |
| Relative Humidity: | 50 % |
| ATM Pressure: | 101.4 kPa |

The testing was performed by Allen Qiao on 206-01-28.

Refer to the following data;

Mode: Transmitting

| Frequency (MHz) | Receiver | | Rx Antenna | | Cable loss (dB) | Amplifier Gain (dB) | Corrected Amplitude (dBµV/m) | FCC 15.247 | |
|--------------------------|----------------|---------------------|-------------|---------------|-----------------|---------------------|------------------------------|----------------|-------------|
| | Reading (dBµV) | Detector (PK/QP/AV) | Polar (H/V) | Factor (dB/m) | | | | Limit (dBµV/m) | Margin (dB) |
| Low Channel: 2406 MHz | | | | | | | | | |
| 2406 | 76.19 | PK | H | 24.83 | 3.67 | 0.00 | 104.69 | N/A | N/A |
| 2406 | 65.48 | AV | H | 24.83 | 3.67 | 0.00 | 93.98 | N/A | N/A |
| 2406 | 86.49 | PK | V | 24.83 | 3.67 | 0.00 | 114.99 | N/A | N/A |
| 2406 | 75.91 | AV | V | 24.83 | 3.67 | 0.00 | 104.41 | N/A | N/A |
| 2390 | 35.01 | PK | V | 24.80 | 3.63 | 0.00 | 63.44 | 74.00 | 10.56 |
| 2390 | 17.51 | AV | V | 24.80 | 3.63 | 0.00 | 45.94 | 54.00 | 8.06 |
| 4812 | 38.17 | PK | V | 29.72 | 5.05 | 27.41 | 45.53 | 74.00 | 28.47 |
| 4812 | 25.67 | AV | V | 29.72 | 5.05 | 27.41 | 33.03 | 54.00 | 20.97 |
| 7218 | 43.89 | PK | V | 33.95 | 6.63 | 25.91 | 58.56 | 74.00 | 15.44 |
| 7218 | 30.48 | AV | V | 33.95 | 6.63 | 25.91 | 45.15 | 54.00 | 8.85 |
| 9624 | 31.58 | PK | V | 36.37 | 8.54 | 27.52 | 48.97 | 74.00 | 25.03 |
| 9624 | 19.09 | AV | V | 36.37 | 8.54 | 27.52 | 36.48 | 54.00 | 17.52 |
| 3205 | 40.58 | PK | V | 26.32 | 6.10 | 27.37 | 45.63 | 74.00 | 28.37 |
| 3205 | 27.84 | AV | V | 26.32 | 6.10 | 27.37 | 32.89 | 54.00 | 21.11 |
| 351.6 | 41.37 | QP | V | 15.26 | 2.26 | 21.65 | 37.24 | 46.00 | 8.76 |
| Middle Channel: 2436 MHz | | | | | | | | | |
| 2436 | 75.06 | PK | H | 24.88 | 3.75 | 0.00 | 103.69 | N/A | N/A |
| 2436 | 65.24 | AV | H | 24.88 | 3.75 | 0.00 | 93.87 | N/A | N/A |
| 2436 | 85.39 | PK | V | 24.88 | 3.75 | 0.00 | 114.02 | N/A | N/A |
| 2436 | 74.32 | AV | V | 24.88 | 3.75 | 0.00 | 102.95 | N/A | N/A |
| 4872 | 37.71 | PK | V | 29.84 | 5.13 | 27.42 | 45.26 | 74.00 | 28.74 |
| 4872 | 25.53 | AV | V | 29.84 | 5.13 | 27.42 | 33.08 | 54.00 | 20.92 |
| 7308 | 43.67 | PK | V | 34.09 | 6.73 | 25.88 | 58.61 | 74.00 | 15.39 |
| 7308 | 30.22 | AV | V | 34.09 | 6.73 | 25.88 | 45.16 | 54.00 | 8.84 |
| 9744 | 31.31 | PK | V | 36.45 | 8.61 | 27.25 | 49.12 | 74.00 | 24.88 |
| 9744 | 18.87 | AV | V | 36.45 | 8.61 | 27.25 | 36.68 | 54.00 | 17.32 |
| 3205 | 40.34 | PK | V | 26.32 | 6.10 | 27.37 | 45.39 | 74.00 | 28.61 |
| 3205 | 27.62 | AV | V | 26.32 | 6.10 | 27.37 | 32.67 | 54.00 | 21.33 |
| 4420 | 35.6 | PK | V | 28.96 | 4.98 | 26.93 | 42.61 | 74.00 | 31.39 |
| 4420 | 22.94 | AV | V | 28.96 | 4.98 | 26.93 | 29.95 | 54.00 | 24.05 |
| 351.6 | 40.53 | QP | V | 15.26 | 2.26 | 21.65 | 36.40 | 46.00 | 9.60 |
| High Channel: 2476 MHz | | | | | | | | | |
| 2476 | 68.92 | PK | H | 24.96 | 3.70 | 0.00 | 97.58 | N/A | N/A |
| 2476 | 58.03 | AV | H | 24.96 | 3.70 | 0.00 | 86.69 | N/A | N/A |
| 2476 | 79.91 | PK | V | 24.96 | 3.70 | 0.00 | 108.57 | N/A | N/A |
| 2476 | 69.26 | AV | V | 24.96 | 3.70 | 0.00 | 97.92 | N/A | N/A |
| 2483.5 | 40.71 | PK | V | 24.97 | 3.67 | 0.00 | 69.35 | 74.00 | 4.65 |
| 2483.5 | 24.31 | AV | V | 24.97 | 3.67 | 0.00 | 52.95 | 54.00 | 1.05 |
| 4952 | 37.5 | PK | V | 30.00 | 5.36 | 27.43 | 45.43 | 74.00 | 28.57 |
| 4952 | 25.14 | AV | V | 30.00 | 5.36 | 27.43 | 33.07 | 54.00 | 20.93 |
| 7428 | 43.35 | PK | V | 34.28 | 6.88 | 25.94 | 58.57 | 74.00 | 15.43 |
| 7428 | 29.73 | AV | V | 34.28 | 6.88 | 25.94 | 44.95 | 54.00 | 9.05 |
| 9904 | 30.92 | PK | V | 36.54 | 8.70 | 26.72 | 49.44 | 74.00 | 24.56 |
| 9904 | 18.54 | AV | V | 36.54 | 8.70 | 26.72 | 37.06 | 54.00 | 16.94 |
| 3205 | 39.88 | PK | V | 26.32 | 6.10 | 27.37 | 44.93 | 74.00 | 29.07 |
| 3205 | 27.22 | AV | V | 26.32 | 6.10 | 27.37 | 32.27 | 54.00 | 21.73 |
| 351.6 | 40.18 | QP | V | 15.26 | 2.26 | 21.65 | 36.05 | 46.00 | 9.95 |

Conducted Spurious Emissions at Antenna Port

Antenna 1 Low Channel

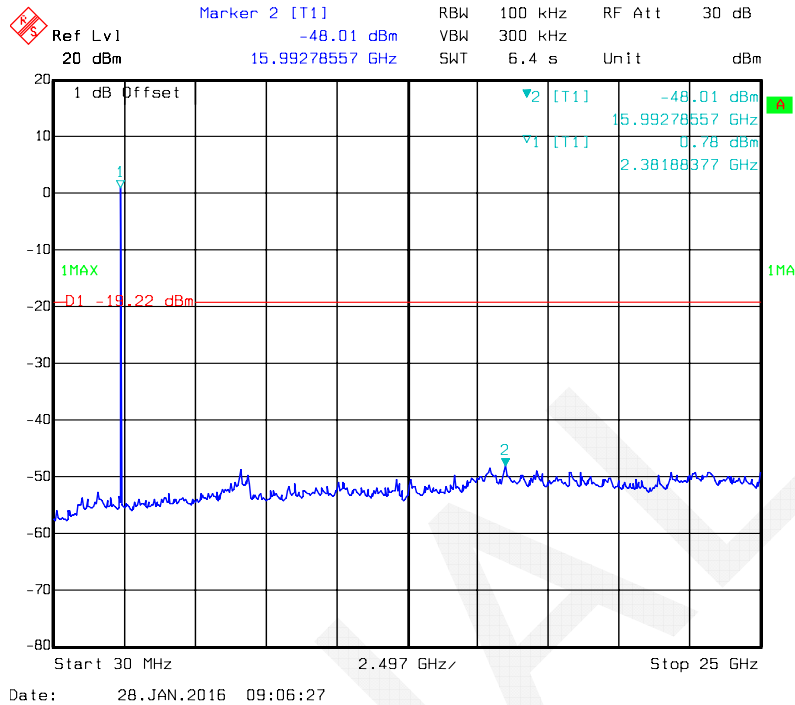

Antenna 1 Middle Channel

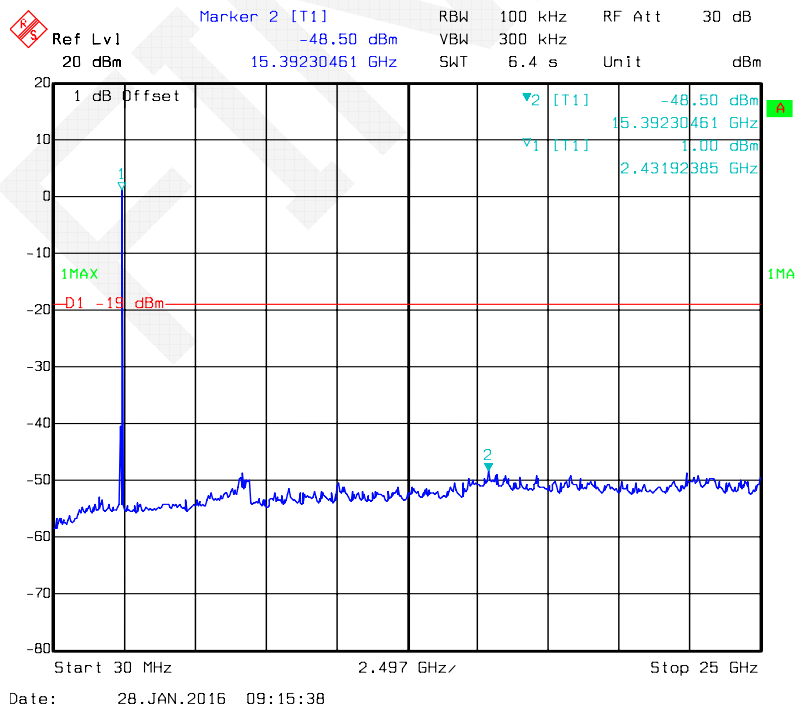

Antenna 1 High Channel

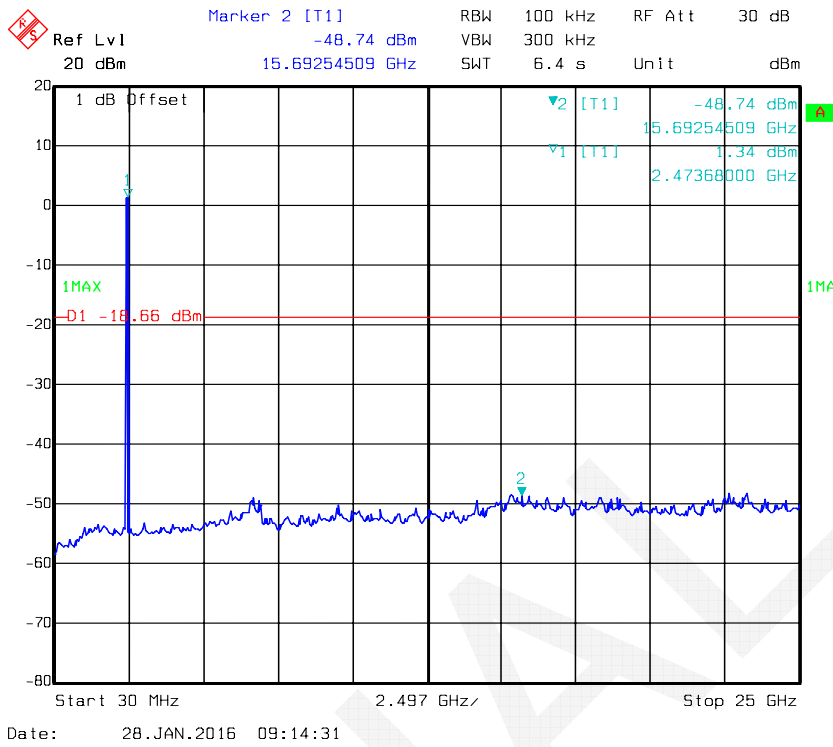

Antenna 2 Low Channel

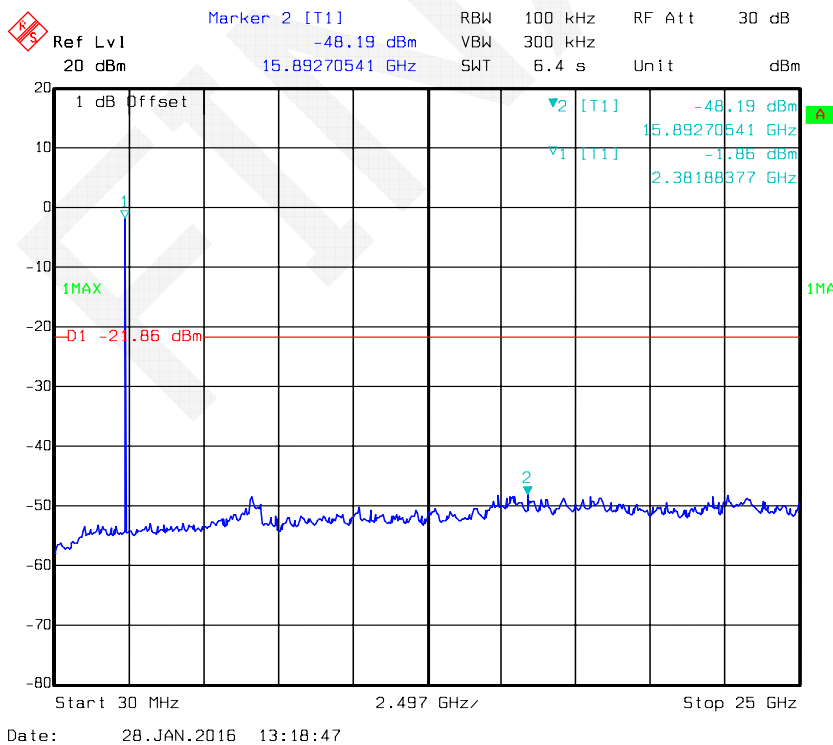

Antenna 2 Middle Channel

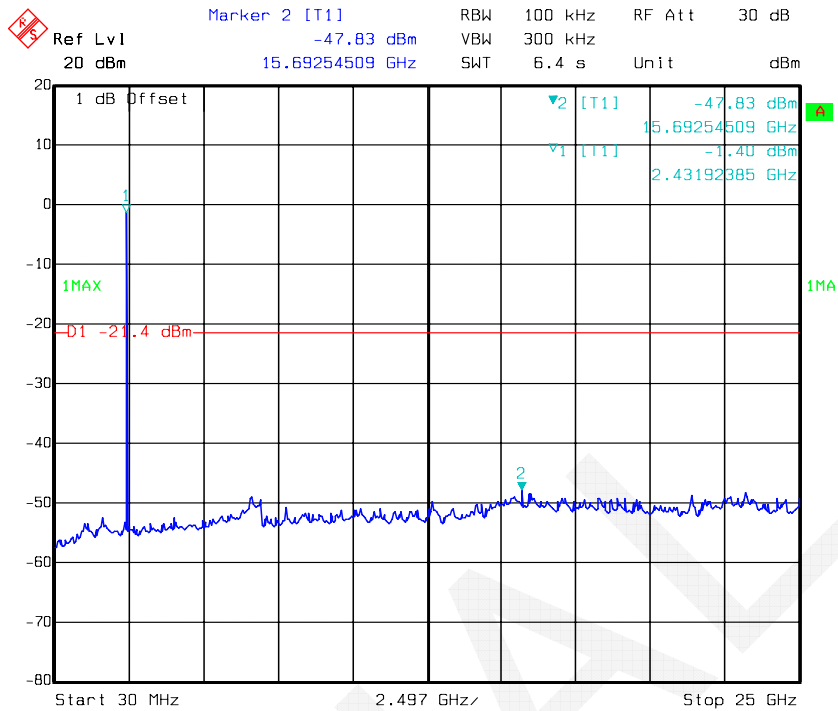

Antenna 2 High Channel

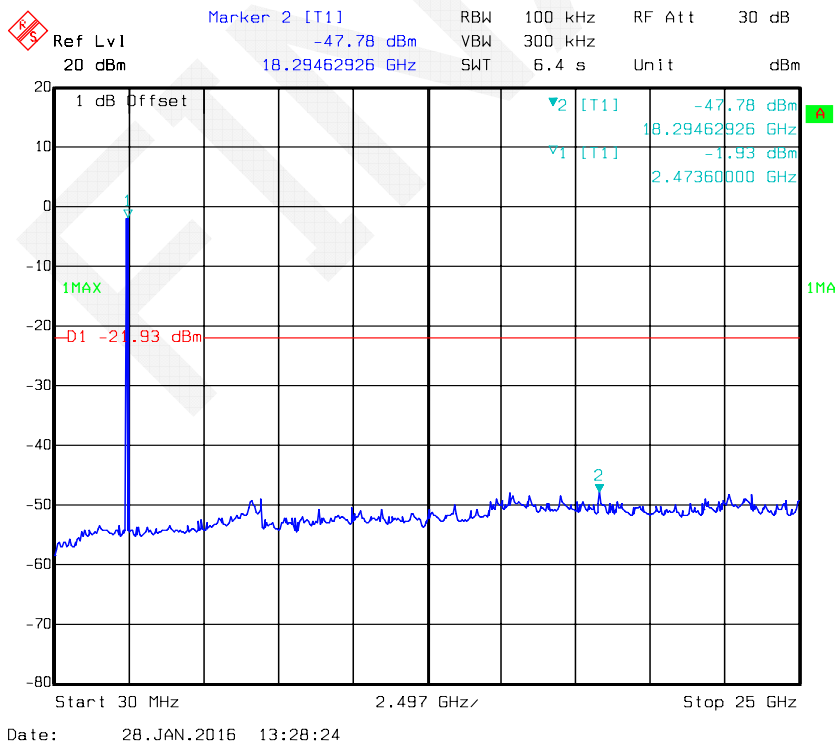

FCC §15.247(a) (2) – 6dB BANDWIDTH

Applicable Standard

Systems using digital modulation techniques may operate in the 902–928 MHz, 2400–2483.5 MHz, and 5725–5850 MHz bands. The minimum 6 dB bandwidth shall be at least 500 kHz.

Test Procedure

1. Check the calibration of the measuring instrument using either an internal calibrator or a known signal from an external generator.
2. Position the EUT without connection to measurement instrument. Turn on the EUT and connect it to measurement instrument. Then set it to any one convenient frequency within its operating range. Set a reference level on the measuring instrument equal to the highest peak value.
3. Measure the frequency difference of two frequencies that were attenuated 6 dB from the reference level. Record the frequency difference as the emission bandwidth.
4. Repeat above procedures until all frequencies measured were complete.

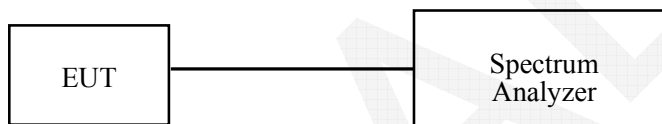

Test Equipment List and Details

| Manufacturer | Description | Model | Serial Number | Calibration Date | Calibration Due Date |
|--------------|-------------------|-------------|---------------|------------------|----------------------|
| R&S | Spectrum Analyzer | FSP 38 | 100478 | 2015-11-23 | 2016-11-22 |
| N/A | Coaxial Cable | 0.1m | N/A | 2015-05-06 | 2016-05-06 |
| E-Microwave | DC Blocking | EMDCB-00036 | 0E01201047 | 2015-05-06 | 2016-05-06 |

* **Statement of Traceability:** Bay Area Compliance Laboratories Corp. (Dongguan) attests that all calibrations have been performed, traceable to National Primary Standards and International System of Units (SI).

Test Data

Environmental Conditions

| | |
|--------------------|-----------|
| Temperature: | 20.5°C |
| Relative Humidity: | 40 % |
| ATM Pressure: | 101.8 kPa |

The testing was performed by Allen Qiao on 2016-01-27.

Test Result: Compliance.

Please refer to the following tables and plots.

Test Mode: Transmitting

| Test Mode | Channel | Frequency | 6 dB Bandwidth | Limit | Result |
|-----------|---------|-----------|----------------|-------|------------|
| | | (MHz) | (MHz) | (MHz) | |
| Antenna 1 | Low | 2406 | 10.24 | 0.5 | Compliance |
| | Middle | 2436 | 10.20 | 0.5 | Compliance |
| | High | 2476 | 10.24 | 0.5 | Compliance |
| Antenna 2 | Low | 2406 | 10.24 | 0.5 | Compliance |
| | Middle | 2436 | 10.20 | 0.5 | Compliance |
| | High | 2476 | 10.24 | 0.5 | Compliance |

FEMVA

Antenna 1 Low Channel

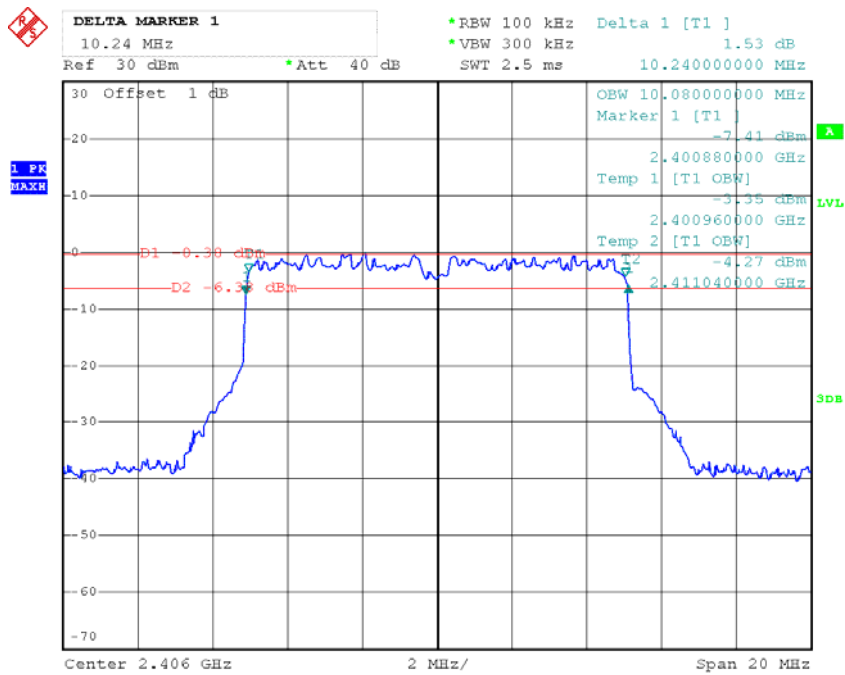

Date: 27.JAN.2016 10:38:24

Antenna 1 Middle Channel

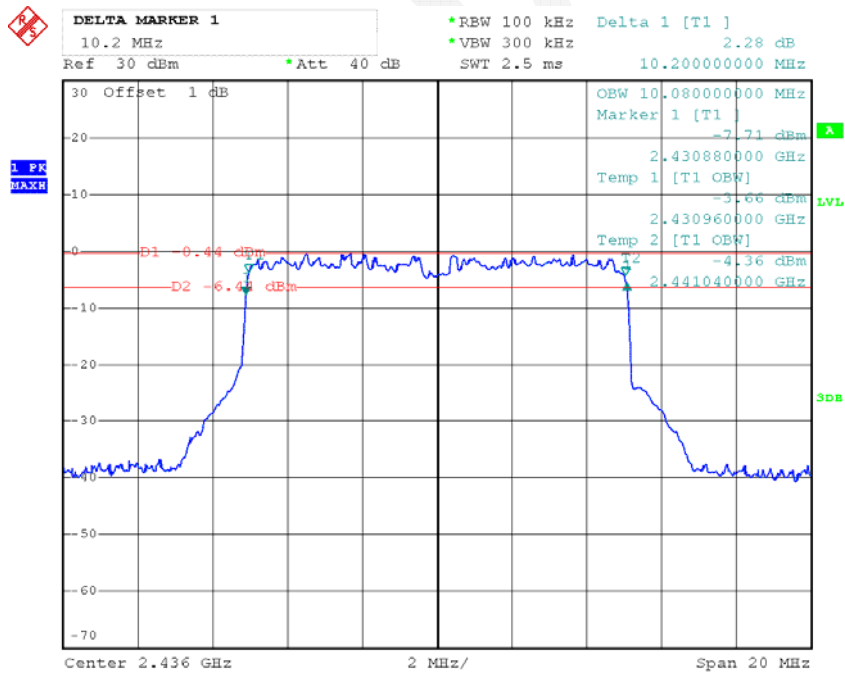

Date: 27.JAN.2016 10:37:25

Antenna 1 High Channel

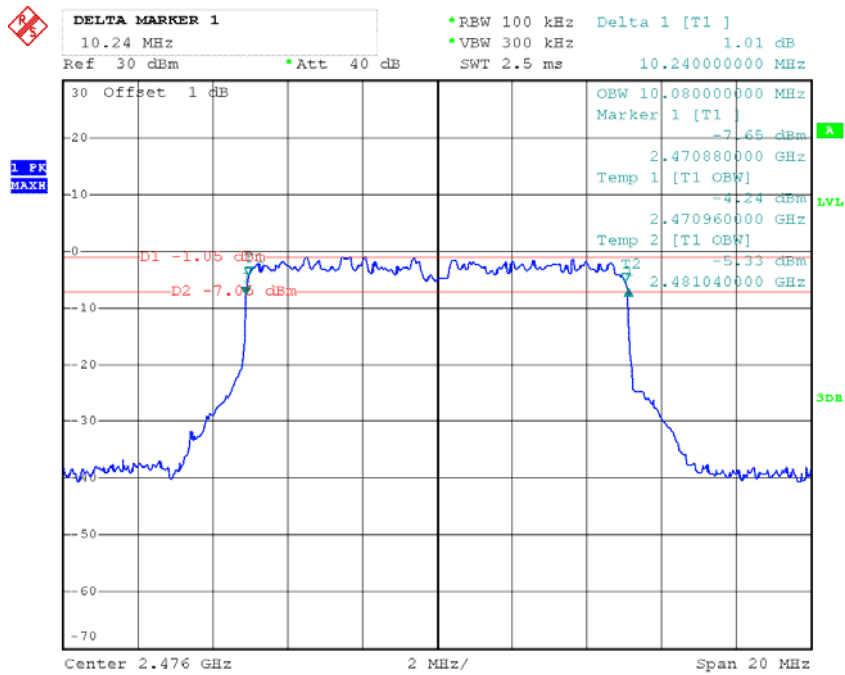

Date: 27.JAN.2016 10:36:34

Antenna 2 Low Channel

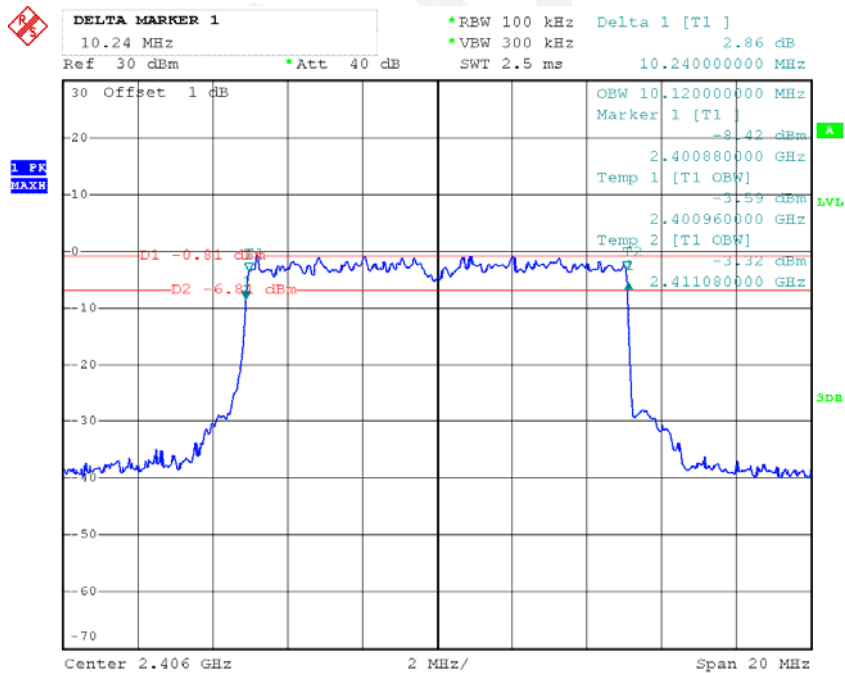

Date: 27.JAN.2016 10:32:59

Antenna 2 Middle Channel

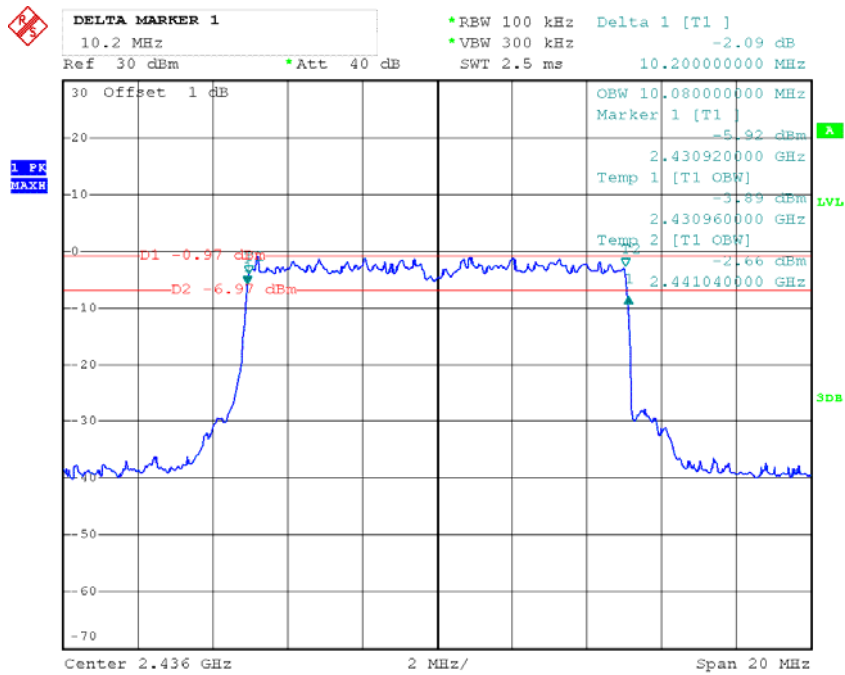

Date: 27.JAN.2016 10:34:01

Antenna 2 High Channel

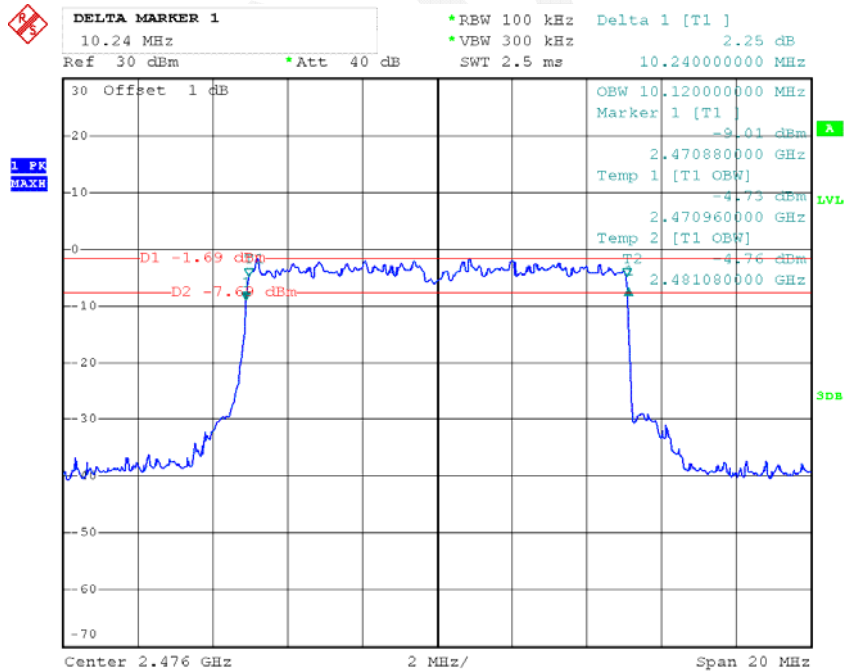

Date: 27.JAN.2016 10:34:58

FCC §15.247(b) (3) - MAXIMUM PEAK CONDUCTED OUTPUT POWER

Applicable Standard

According to FCC §15.247(b) (3), for systems using digital modulation in the 902-928 MHz, 2400-2483.5 MHz, and 5725-5850 MHz bands: 1 Watt. As an alternative to a peak power measurement, compliance with the one Watt limit can be based on a measurement of the maximum conducted output power. Maximum Conducted Output Power is defined as the total transmit power delivered to all antennas and antenna elements averaged across all symbols in the signaling alphabet when the transmitter is operating at its maximum power control level. Power must be summed across all antennas and antenna elements. The average must not include any time intervals during which the transmitter is off or is transmitting at a reduced power level. If multiple modes of operation are possible (e.g., alternative modulation methods), the maximum conducted output power is the highest total transmit power occurring in any mode.

Test Procedure

1. Place the EUT on a bench and set it in transmitting mode.
2. Remove the antenna from the EUT and then connect a low loss RF cable from the antenna port to a Test Equipment.



Test Equipment List and Details

| Manufacturer | Description | Model | Serial Number | Calibration Date | Calibration Due Date |
|--------------|-----------------------|-------------|---------------|------------------|----------------------|
| Agilent | Wideband Power Sensor | N1921A | MY54210016 | 2015-11-03 | 2016-11-03 |
| Agilent | Wideband Power Sensor | N1921A | MY54170013 | 2015-11-03 | 2016-11-03 |
| Agilent | P-Series Power Meter | N1912A | MY5000448 | 2015-11-03 | 2016-11-03 |
| N/A | Coaxial Cable | 0.1m | N/A | 2015-05-06 | 2016-05-06 |
| E-Microwave | DC Blocking | EMDCB-00036 | 0E01201047 | 2015-05-06 | 2016-05-06 |

* **Statement of Traceability:** Bay Area Compliance Laboratories Corp. (Dongguan) attests that all calibrations have been performed, traceable to National Primary Standards and International System of Units (SI).

Test Data

Environmental Conditions

| | |
|--------------------|-----------|
| Temperature: | 21.5°C |
| Relative Humidity: | 50 % |
| ATM Pressure: | 101.4 kPa |

The testing was performed by Allen Qiao on 2016-01-28.

Test Mode: Transmitting

| Channel | Frequency | Peak Conducted Output Power (dBm) | | | Limit | Result |
|---------|-----------|-----------------------------------|--------|-------|-------|------------|
| | MHz | Ant. 1 | Ant. 2 | Total | dBm | |
| Low | 2406 | 17.73 | 17.40 | 20.58 | 27.3 | Compliance |
| Middle | 2436 | 17.58 | 17.24 | 20.42 | 27.3 | Compliance |
| High | 2476 | 16.94 | 16.48 | 19.73 | 27.3 | Compliance |

Note: the two antenna gain is 5.7dBi, the directional gain is 8.7 dBi, so the power limit should reduce 2.7 dBi.



FCC §15.247(d) – 100 kHz BANDWIDTH OF FREQUENCY BAND EDGE

Applicable Standard

In any 100 kHz bandwidth outside the frequency band in which the spread spectrum or digitally modulated intentional radiator is operating, the radio frequency power that is produced by the intentional radiator shall be at least 20 dB below that in the 100 kHz bandwidth within the band that contains the highest level of the desired power, based on either an RF conducted or a radiated measurement, provided the transmitter demonstrates compliance with the peak conducted power limits. If the transmitter complies with the conducted power limits based on the use of RMS averaging over a time interval, as permitted under paragraph (b)(3) of this section, the attenuation required under this paragraph shall be 30 dB instead of 20 dB. Attenuation below the general limits specified in §15.209(a) is not required. In addition, radiated emissions which fall in the restricted bands, as defined in §15.205(a), must also comply with the radiated emission limits specified in §15.209(a) (see §15.205(c)).

Test Procedure

1. Check the calibration of the measuring instrument using either an internal calibrator or a known signal from an external generator.
2. Position the EUT without connection to measurement instrument. Turn on the EUT and connect its antenna terminal to measurement instrument via a low loss cable. Then set it to any one measured frequency within its operating range, and make sure the instrument is operated in its linear range.
3. Set RBW to 100 kHz and VBW of spectrum analyzer to 300 kHz with a convenient frequency span including 100 kHz bandwidth from band edge.
4. Measure the highest amplitude appearing on spectral display and set it as a reference level. Plot the graph with marking the highest point and edge frequency.
5. Repeat above procedures until all measured frequencies were complete.

Test Equipment List and Details

| Manufacturer | Description | Model | Serial Number | Calibration Date | Calibration Due Date |
|--------------|-------------------|-------------|---------------|------------------|----------------------|
| R&S | Spectrum Analyzer | FSP 38 | 100478 | 2015-11-23 | 2016-11-22 |
| N/A | Coaxial Cable | 0.1m | N/A | 2015-05-06 | 2016-05-06 |
| E-Microwave | DC Blocking | EMDCB-00036 | 0E01201047 | 2015-05-06 | 2016-05-06 |

* **Statement of Traceability:** Bay Area Compliance Laboratories Corp. (Dongguan) attests that all calibrations have been performed, traceable to National Primary Standards and International System of Units (SI).

Test Data

Environmental Conditions

| | |
|---------------------------|-----------|
| Temperature: | 20.5°C |
| Relative Humidity: | 40 % |
| ATM Pressure: | 101.8 kPa |

The testing was performed by Allen Qiao on 2016-01-27.

Test Result: *Compliance*

Please refer to following plots.

Antenna 1: Band Edge, Left Side

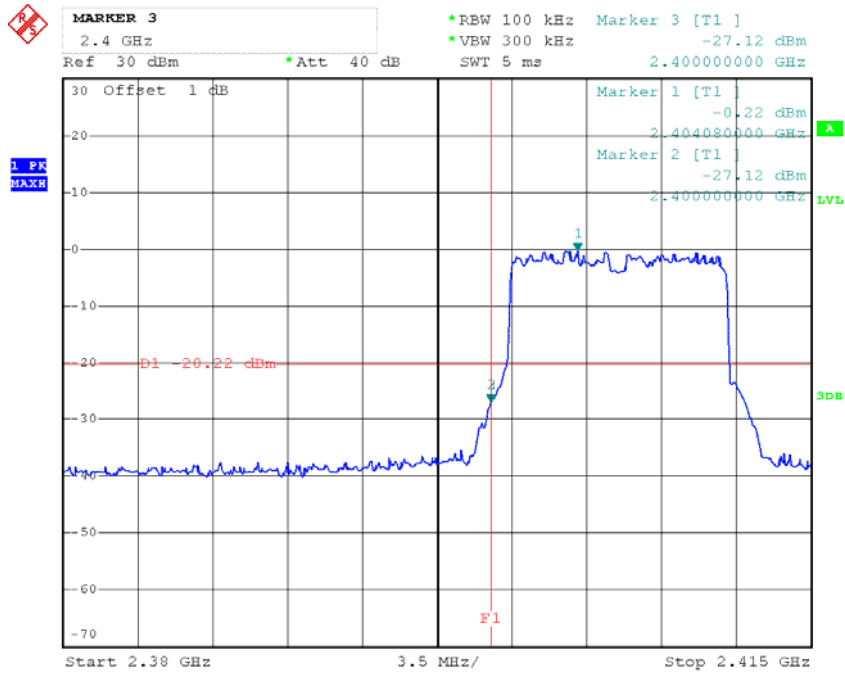

Date: 27.JAN.2016 10:48:48

Antenna 1: Band Edge, Right Side

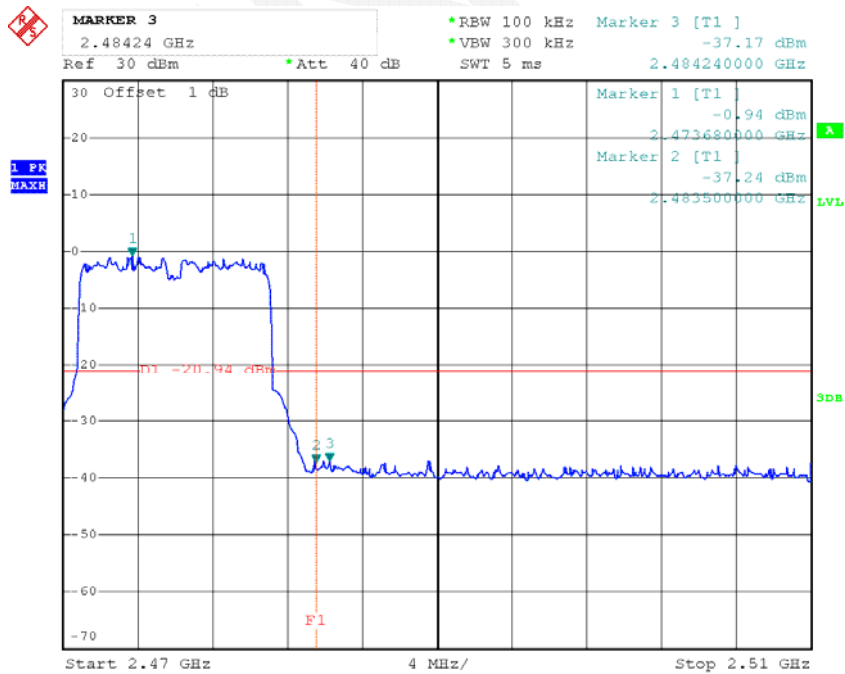

Date: 27.JAN.2016 10:52:13

Antenna 2: Band Edge, Left Side

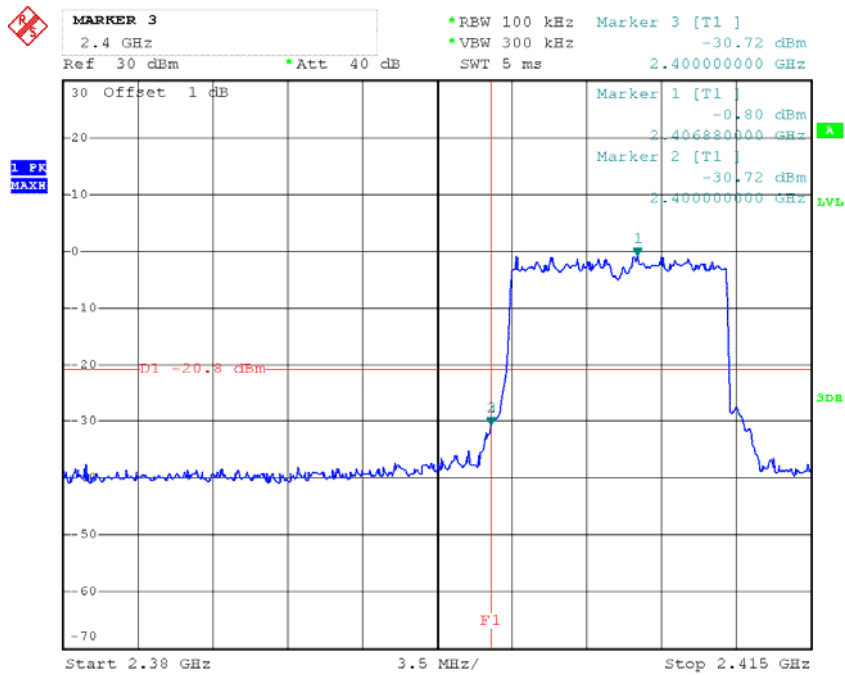

Date: 27.JAN.2016 10:49:37

Antenna 2: Band Edge, Right Side

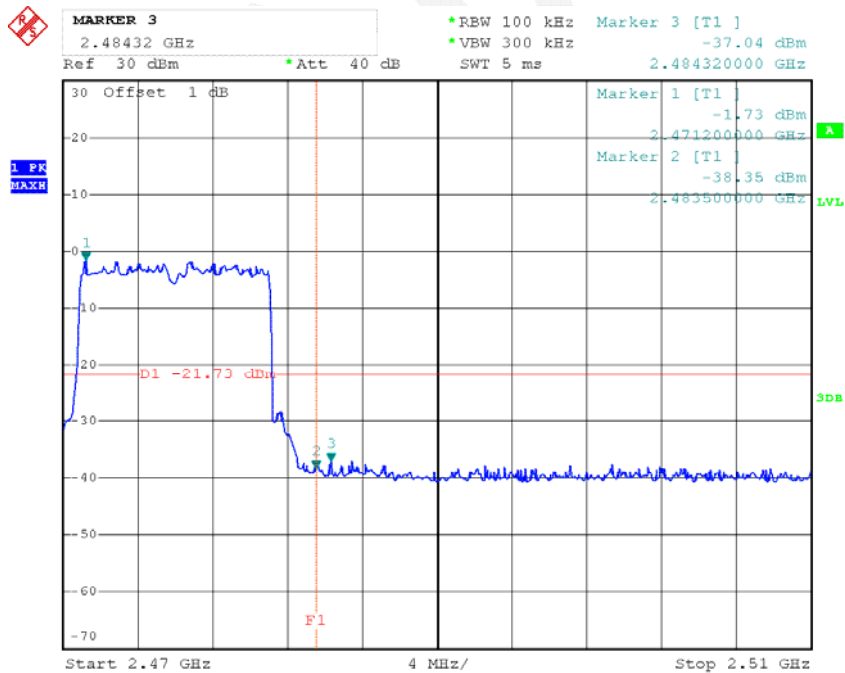

Date: 27.JAN.2016 10:53:18

FCC §15.247(e) - POWER SPECTRAL DENSITY

Applicable Standard

For digitally modulated systems, the power spectral density conducted from the intentional radiator to the antenna shall not be greater than 8 dBm in any 3 kHz band during any time interval of continuous transmission. This power spectral density shall be determined in accordance with the provisions of paragraph (b) of this section. The same method of determining the conducted output power shall be used to determine the power spectral density.

Test Procedure

1. Check the calibration of the measuring instrument using either an internal calibrator or a known signal from an external generator.
2. Position the EUT was set without connection to measurement instrument. Turn on the EUT and connect its antenna terminal to measurement instrument via a low loss cable. Then set it to any one measured frequency within its operating range, and make sure the instrument is operated in its linear range.
3. Set the RBW = 3 kHz, VBW = 10 kHz, Set the span to 1.5 times the DTS bandwidth.
4. Use the peak marker function to determine the maximum amplitude level.

Test Equipment List and Details

| Manufacturer | Description | Model | Serial Number | Calibration Date | Calibration Due Date |
|--------------|-------------------|-------------|---------------|------------------|----------------------|
| R&S | Spectrum Analyzer | FSP 38 | 100478 | 2015-11-23 | 2016-11-22 |
| N/A | Coaxial Cable | 0.1m | N/A | 2015-05-06 | 2016-05-06 |
| E-Microwave | DC Blocking | EMDCB-00036 | 0E01201047 | 2015-05-06 | 2016-05-06 |

* **Statement of Traceability:** Bay Area Compliance Laboratories Corp. (Dongguan) attests that all calibrations have been performed, traceable to National Primary Standards and International System of Units (SI).

Test Data

Environmental Conditions

| | |
|--------------------|-----------|
| Temperature: | 20.5°C |
| Relative Humidity: | 40 % |
| ATM Pressure: | 101.8 kPa |

The testing was performed by Allen Qiao on 2016-01-27.

Test Mode: Transmitting

Test Result: Compliance*Test Mode: Transmitting*

| Channel | Frequency | Power Spectral Density (dBm/3kHz) | | | Limits |
|---------|-----------|--------------------------------------|--------|--------|----------|
| | MHz | Ant. 1 | Ant. 2 | Total | dBm/3kHz |
| Low | 2406 | -16.51 | -17.29 | -13.87 | 5.3 |
| Middle | 2436 | -16.59 | -17.47 | -14.00 | 5.3 |
| High | 2476 | -17.32 | -18.22 | -14.74 | 5.3 |

Note: the two antenna gain is 5.7dBi, the directional gain is 8.7 dBi, so the limit should reduce 2.7 dBi.

Please refer to the following plots

FEMVA

Power Spectral Density, Antenna 1 Low Channel

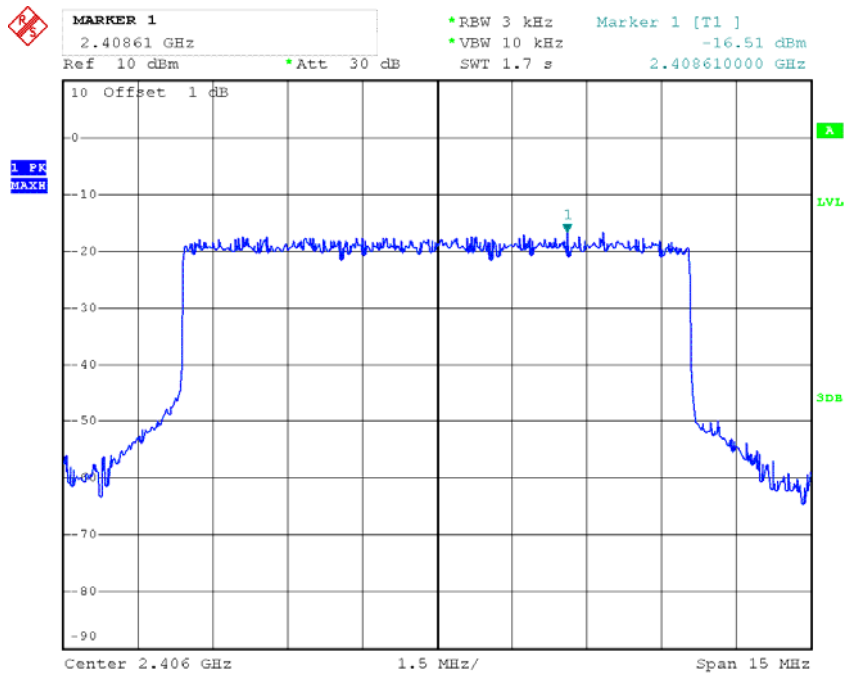

Date: 27.JAN.2016 10:58:05

Power Spectral Density, Antenna 1 Middle Channel

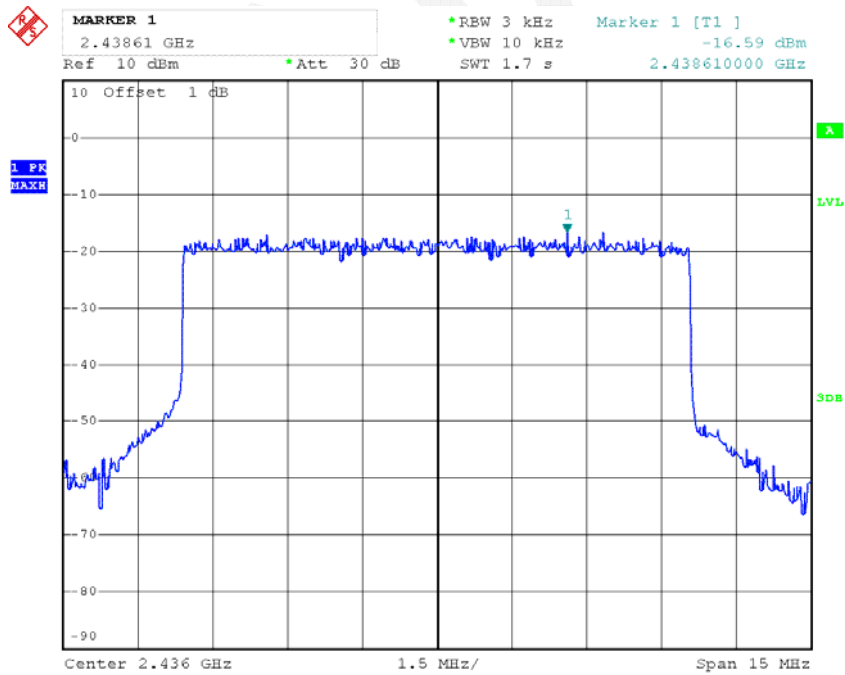

Date: 27.JAN.2016 10:58:39

Power Spectral Density, Antenna 1 High Channel

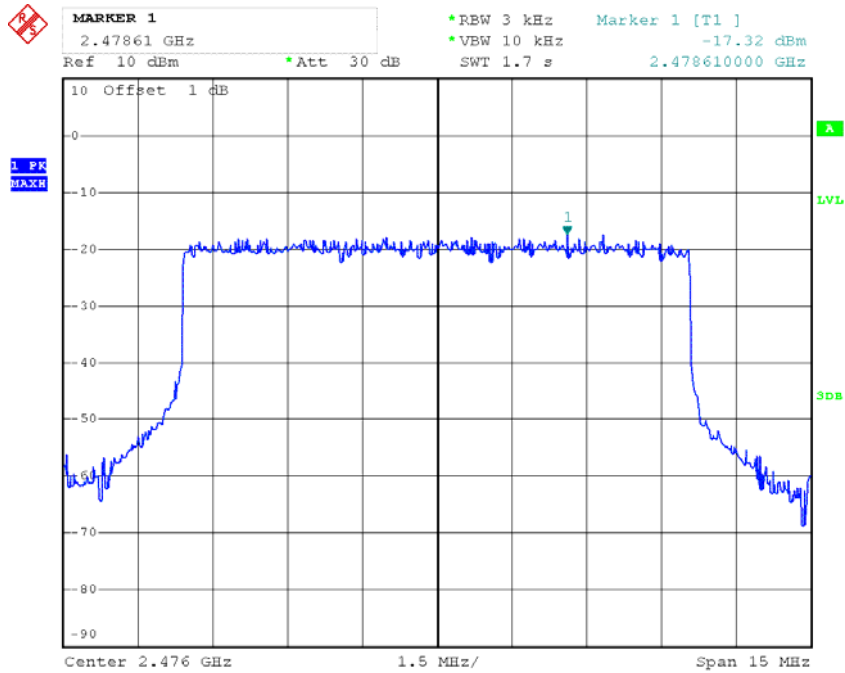

Date: 27.JAN.2016 10:59:07

Power Spectral Density, Antenna 2 Low Channel

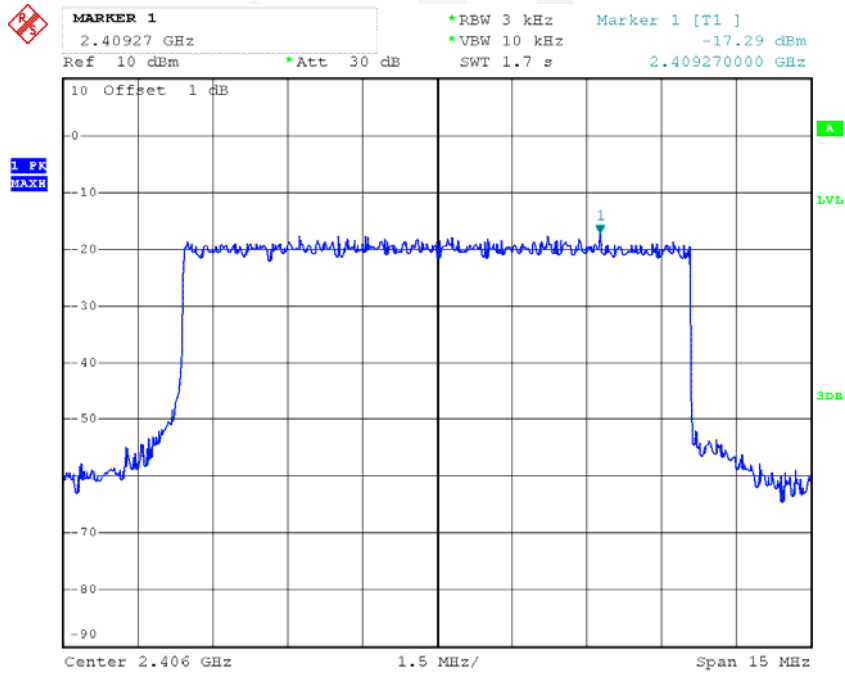

Date: 27.JAN.2016 11:00:51

Power Spectral Density, Antenna 2 Middle Channel

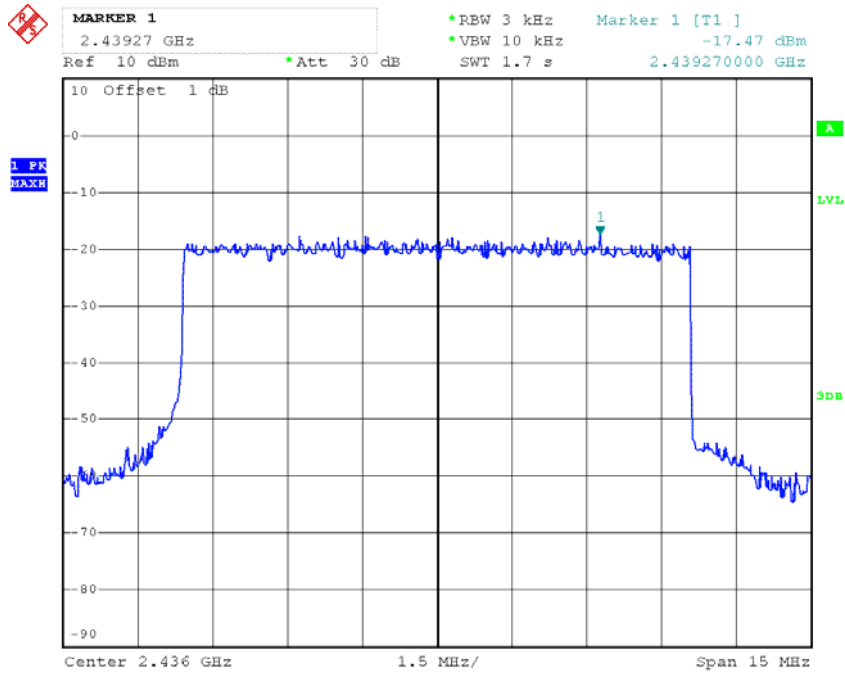

Date: 27.JAN.2016 11:00:24

Power Spectral Density, Antenna 2 High Channel

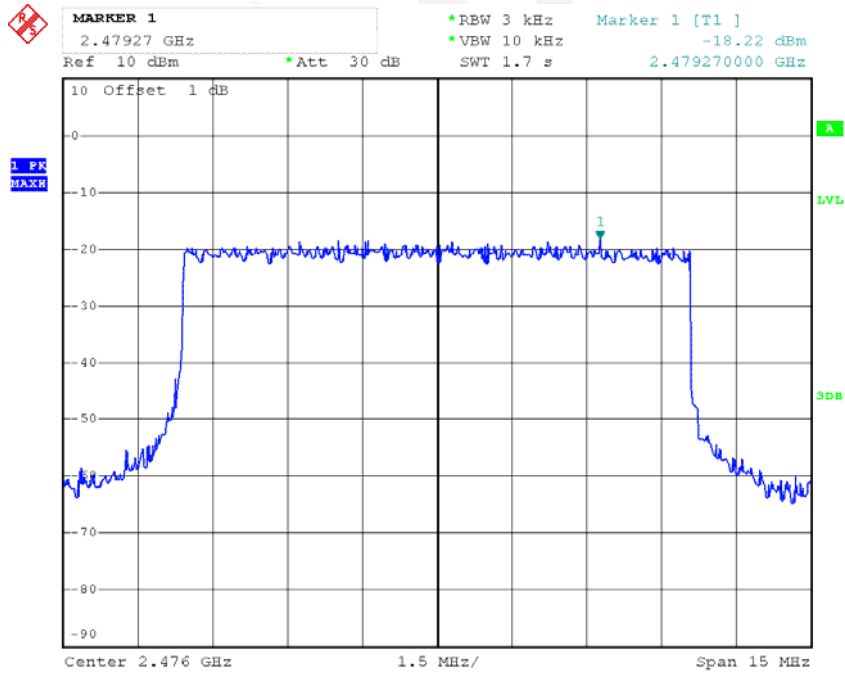

Date: 27.JAN.2016 10:59:44

*****END OF REPORT*****