

Akubela User Guide

For HyPanel Lux



Contents

Introduction.....	1
Before You Start.....	2
What the home center device is.....	3
Log in to user web portal.....	4
Get started.....	6
Your HyPanel Lux	6
Wake and Unlock HyPanel Lux.....	7
Wake the panel.....	7
Unlock the Screen.....	8
Interact with HyPanel Lux.....	8
Touch screen.....	9
Outer rim.....	9
Physical buttons.....	9
Check the server status.....	10
Personalize Your System.....	13
Connect to the Internet.....	13
Change your Wi-Fi network.....	14
Configure LAN network.....	14
Change system language.....	15
Change the date and time.....	16

<i>Change the Home screen style</i>	17
<i>Put HyPanel Lux in standby mode</i>	19
<i>Change the screen saver settings</i>	20
<i>Adjust the screen brightness</i>	21
<i>Adjust brightness manually</i>	21
<i>Adjust brightness automatically when lighting changes</i>	22
<i>Set sounds and ringtones</i>	22
<i>Change sounds and ringtones</i>	23
<i>Set up Do Not Disturb</i>	24
<i>Quickly turn DND on or off</i>	24
<i>Schedule the DND to turn on automatically</i>	25
<i>Protect your HyPanel Lux</i>	26
<i>Set up screen lock</i>	27
<i>Set up settings screen lock</i>	27
<i>Use HyPanel Lux without Cloud connectivity</i>	28
<i>Manage Devices</i>	30
<i>Add Zigbee Devices</i>	30
<i>Put Devices in pairing mode</i>	31
<i>Pair devices with HyPanel Lux</i>	32
<i>Add third-party smart home devices</i>	34
<i>See device information</i>	35
<i>Check if the device is connected</i>	35

<i>See where the device is located</i>	36
<i>Filter devices by locations</i>	36
<i>Add devices to Favorites</i>	37
<i>Customize the All Devices screen</i>	39
<i>Rearrange the devices</i>	39
<i>Reorder the room list</i>	39
<i>Control devices</i>	40
<i>Control relays</i>	40
<i>Control sockets</i>	42
<i>Control door locks</i>	42
<i>Home Automation</i>	43
<i>Activate your scene</i>	43
<i>Automation scene types</i>	43
<i>Run a scene with manual activation conditions</i>	44
<i>Run a scene with time or action conditions</i>	45
<i>Customize the Scenes screen</i>	46
<i>Add Scenes to Favorites</i>	46
<i>Security</i>	48
<i>Arm your home</i>	48
<i>Disarm your system</i>	50
<i>Disable alarm siren and alarm push</i>	52
<i>See the alarm logs</i>	53

<i>Lighting</i>	54
<i>Turn a light on or off</i>	54
<i>Make the light brighter or dimmer</i>	54
<i>Change the light color</i>	55
<i>Make the light color warmer or cooler</i>	55
<i>Environment</i>	56
<i>Comfort</i>	56
<i>Change Ecobee mode</i>	57
<i>Timer and alarm clock</i>	57
<i>Set an alarm clock</i>	59
<i>Energy</i>	62
<i>Use the intercom</i>	65
<i>Unlock the door remotely</i>	65
<i>Unlock the door before answering a call</i>	65
<i>Unlock the door during a call</i>	66
<i>Communication in Family</i>	67
<i>Family Accounts</i>	68
<i>Make one-to-one voice calls</i>	68
<i>Send audio messages</i>	70
<i>See text messages</i>	71
<i>Update, Restart, and Reset</i>	72
<i>Update the system</i>	72

<i>Restart your HyPanel Lux</i>	73
<i>Restore HyPanel Lux to installer settings</i>	74
<i>Privacy Policy</i>	75
<i>Get Help</i>	76

Introduction

This guide provides an overview of the features and functions of Akubela HyPanel Lux (version 61.1.20.130). Topics covered by this guide include but not limited to:

- *Overview of Akubela Home Center.*
- *Personalizing the system your way.*
- *Managing and controlling add-on Zigbee and third-party devices.*
- *Creating and using Scene function to automate your home.*
- *Communicating with devices and family members using HyPanel Lux.*

For more information about products and operations, see the appropriate guides at <https://knowledge.akuvox.com/>.

Before You Start

Akubela allows you to configure and control your home devices on panels, and via the user web portal and BelaHome app. Their features and capabilities vary.

This section gives you an insight into what the home center device is, what you can do on the user web portal and how to log in to it.

What the home center device is

The Akubela device that is selected to be the only superior controlling hub within a family, is called home center. Each home center has an online user web portal for advanced settings. With the Home Center and the web portal, you are empowered to:

- *Manage all family members accounts.*
- *Change the system's running modes.*
- *Add devices and manage all devices within the family.*
- *Create and personalize home automation scenes.*
- *Configure the default security modes and create custom modes.*

A family has only one Home Center. The following are the devices that can be the Home Center:

- *SmartPanel*
- *SmartPanel Pro*
- *HyPanel Lux*
- *HyPanel*

Log in to user web portal

To log in to the user web portal, do one of the following based on the connection mode:

1. In the Cloud mode. Log in to the family's administrator account at <https://my.akubela.com>.

2. In the Off-Cloud mode.

- Make sure your computer and the devices are on the same local network.
- Type in the home center device's IP address into the browser.

`192.168.1.103/auth/authorize?response_type=code&redirect_uri=http%3A%2F%2F192.168.1.103%2F%3Fauth_callback%3D1&client_id=http%3A%2F%2F192.168.1.103%2F&state=eyJ0YXNzZV`

- Log in with the family's administrator account.

To know what the Off-Cloud mode is? See [here](#).

3. In the Trial mode.

- Make sure your computer and the devices are on the same local network.
- Type in the device's IP address into the browser.
- Log in with the username, *Admin888*, and the password, *Admin888*.

How to get the family administrator account?

Contact your service provider, and provide a valid email address and other required information. Once the installation of your Akubela devices completed, the administrator will receive a Welcome to Akubela email with login credentials.

You can see [Appendix](#) to learn more about what you can do on the user web portal.

Get started

Your HyPanel Lux

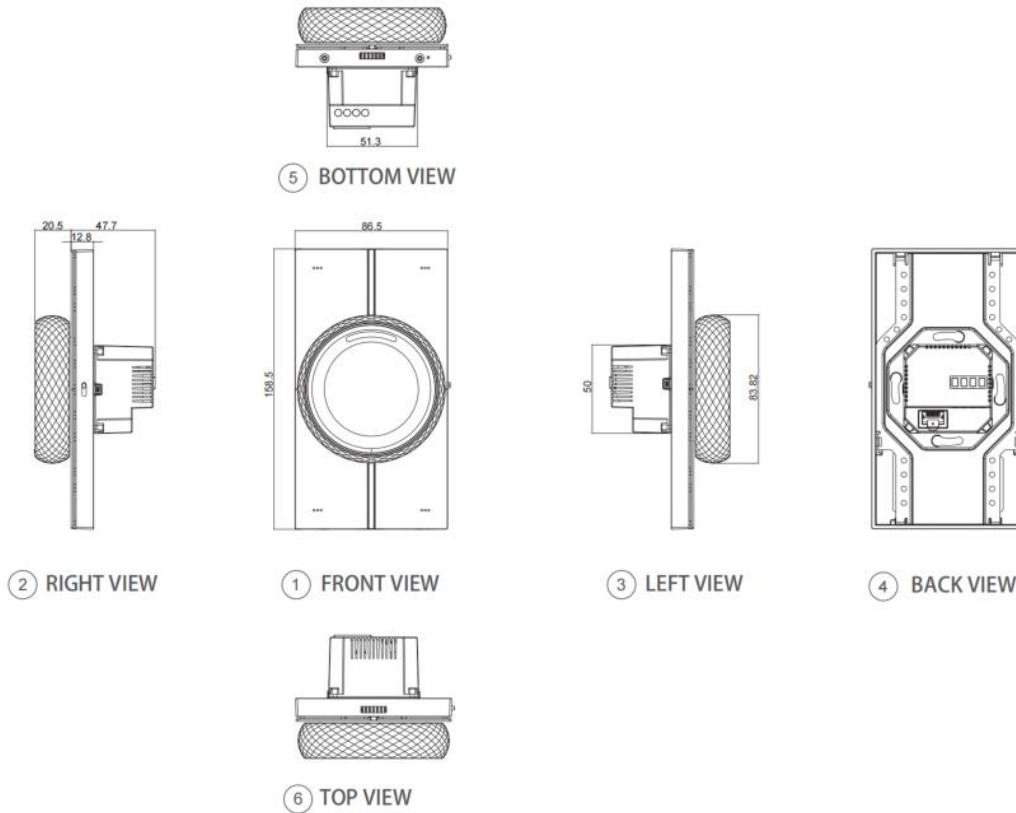

Wake and Unlock HyPanel Lux

You can quickly wake up your HyPanel Lux from the standby mode when you want to use it again.

Wake the panel

To wake your HyPanel Lux, do one of the following:

- Tap anywhere of the screen.
- Approach HyPanel Lux to have it wake up automatically.

To change the presence settings, go to **Settings**  > **Motion**, and turn off **Proximity Sensor** to disable the approach to wake up function, or adjust **Proximity Detection Distance**.

NOTE:

There are two options for Proximity Detection Distance: Long distance and Short distance. The long distance is 60cm(ca. 24 inches), and the short one is 30cm (12 inches).



Unlock the Screen

If you've set up the screen lock, you need to unlock the screen by drawing a pattern before you can access the device.

- 1. Wake the HyPanel Lux.*
- 2. Draw the preset pattern.*

If you did not set up the screen lock, see [Set up screen lock](#) section in this guide.

Interact with HyPanel Lux

There are three methods to interact with or control HyPanel Lux: Tap on the touch screen, rotate the outer rim, and press the physical buttons.

Touch screen

To turn pages or move among options, slide on the touch screen.

To select, just tap what you need.

Outer rim

You can also rotate the outer rim to turn pages or choose among options. To select, rotate to the desired option and wait 2 seconds to enter the detail screen.

Please note that the interaction methods may vary by the home screen style. For more information, see the section [Change the Home screen style](#).

HyPanel Lux gives you two rotating sensation: One is stepless and smooth, the other is stepped and clicking. To change or experience the different rotating feedback, just toggle the physical switch on the long side edge of the device.



Physical buttons

To turn on/off the 2 connected relays, you can press the four physical buttons

directly.

No matter whether your HyPanel Lux is installed horizontally or vertically, the upper 2 physical buttons are always to control relay 1 and the rest for relay 2.

Check the server status

If some features of your HyPanel Lux do not work, you should firstly access the *Connect Info* to check if it disconnects with the cloud server.

1. On Home screen, select *Settings* by tapping the icon .

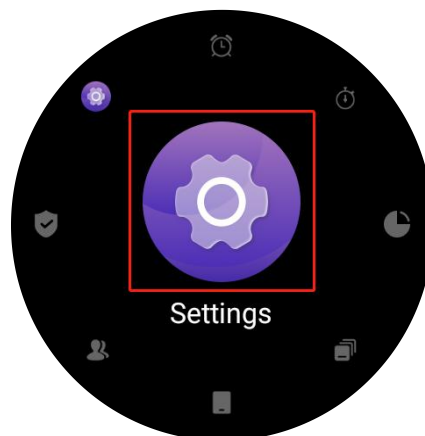

2. Select *Connect Info*.

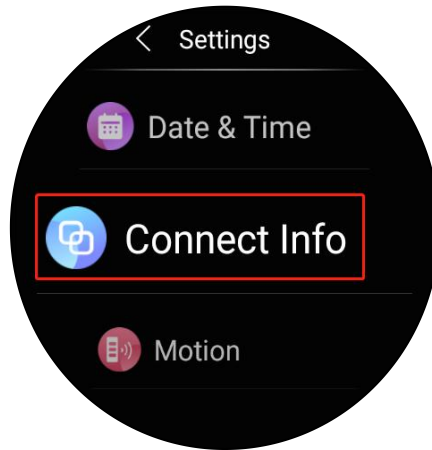

- *Your device's connection status is normal if you see the screen below.*

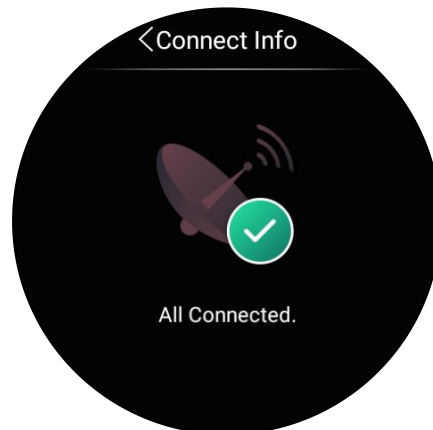

- *Contact your service provider or Akubela technical team for help if you see Connection Error.*

< Connect Info



Connection Error

Check Status Code

Personalize Your System

Connect to the Internet

The network is usually configured by your service provider during the installation.

You may be asked to connect to a network if you restored your HyPanel Lux. You can change the Wi-Fi network or connect the device to a local area network (LAN) anytime during the use.

Change your Wi-Fi network

1. On the Home screen, select **Settings** by tapping the icon .



2. Choose the desired network from the available network list.
3. Enter the password if required, and tap **Join**.

Configure LAN network

You can configure a LAN network if needed.

1. On the Home screen, select **Settings** by tapping the icon .
2. Select **Network**, and do any of the following:
 - Toggle on **DHCP** feature, and the device will be assigned IP address automatically.



- Toggle off DHCP feature, then enter IP Address, Sub-net Mask, Gateway, Preferred DNS Server, and Alternate DNS Server manually.

Change system language

You can change the language to your preferred one.

To set a language, go to Settings  > Language.

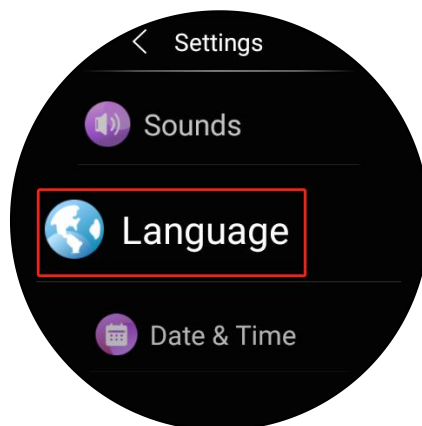

NOTE:

HyPanel Lux devices supports only English now.

You can also set up all devices' system language on user web portal.

Change the date and time

You can change the time zone, the date and time if you want.

1. Go to Settings  > Date & Time.



2. Do any of the following:

- Toggle on Set Automatically. The device gets the time over the NTP server and update to the time zone you're in.
- Toggle on 24-hour time. The device uses the numbers 00:00 to 23:59 to tell the time.
- Select the time zone.

To change the time and date, toggle off *Set Automatically*, then set the time and date.

Change the Home screen style

You can change your home screen styles to your preference.

1. Go to *Settings*  > *Display* > *Homepage style*.

2. Select any of the following:

- *Style 1*



- *To reorder the features, hold and drag any of them to the desired location.*
- *To go to the specific feature screen, tap its icon, or center its icon on the Home screen, and rotate the outer rim clockwise.*

- **Style 2**

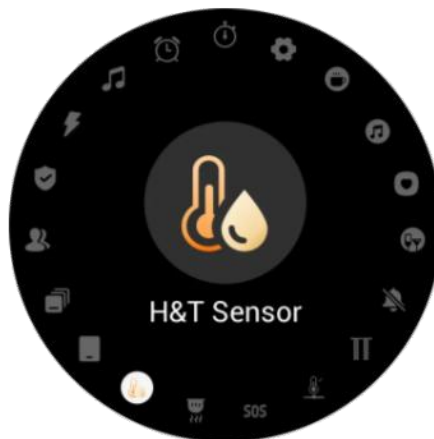

- *To go to the specific feature screen, tap its icon, or rotate the outer rim to it and wait 2 seconds.*

Put HyPanel Lux in standby mode

The Standby mode helps to keep your HyPanel Lux secure and save battery power.

You can customize how long the device takes to enter the standby mode by going to

Settings  > Display > Put in Standby. For example, if you set it as 1 min, then HyPanel Lux will enter standby mode in 1 minute of inactivity.



To put the HyPanel Lux in the standby mode at once, swipe down from the top edge of any screen, then tap .

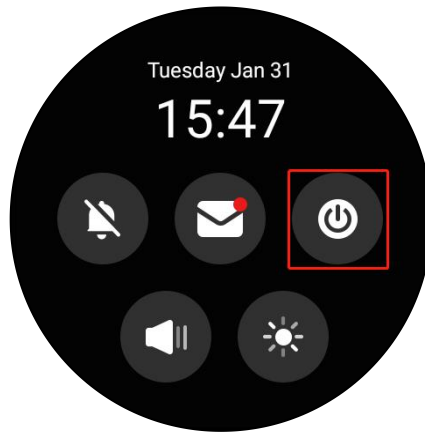

Change the screen saver settings

In Display settings, you can turn the screen saver on or off, and choose the screen saver style.

1. Go to Settings  > Display.
2. Do any of the following:
 - Turn on or off the screensaver feature by moving the toggle next to Screensaver On.

If it is on, HyPanel Lux in standby mode will play preset images. You can upload your favorite photos from the BelaHome app, so they can be displayed on the selected device.

- Choose a Screensaver Style. Note that the preset images can only be played

in these two modes (see the pictures below).

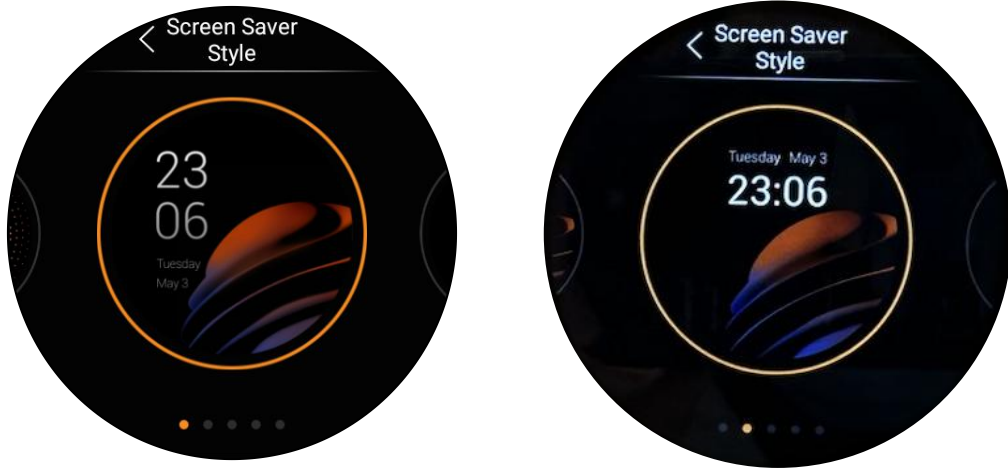

- Schedule the screensaver to turn on automatically by setting Screensaver Times.

Adjust the screen brightness

You can manually adjust the screen brightness level, or let our HyPanel Lux automatically adjust brightness based on the current lighting conditions.

Adjust brightness manually

1. Swipe down from the top edge of any screen, and tap .
2. Do any of the following to adjust the brightness:
 - Drag the slider on the touch screen.
 - Rotate the outer rim.

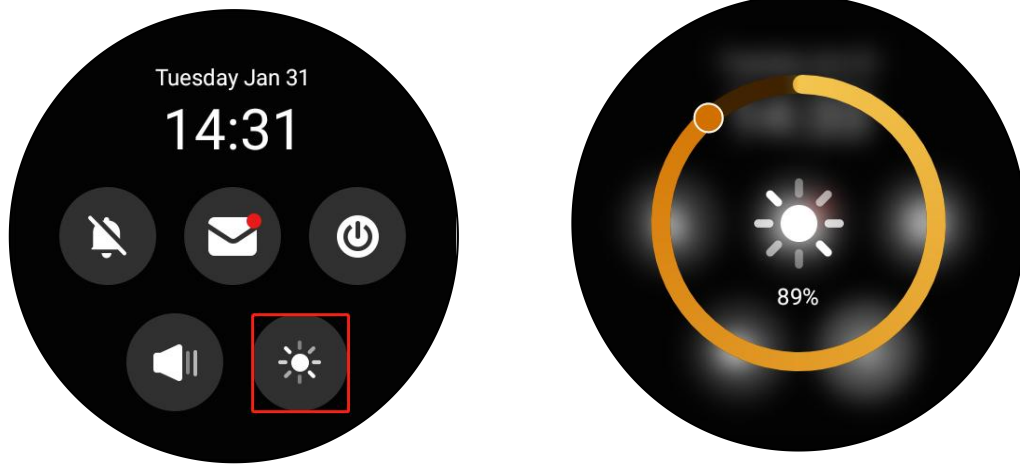

Adjust brightness automatically when lighting changes

Go to *Settings*  > *Display*, then toggle on *Automatic Brightness Control*.



Set sounds and ringtones

You can change incoming ringtones and information sounds, and adjust the volumes of calls, alerts, clock alarms, touch tone, and notifications.

Change sounds and ringtones

1. Go to Settings  > Sounds.
2. On the Sounds screen, do any of the following:
 - Turn the touch tone on or off.
 - Set an incoming call ringtone.
 - Set an information sound.



Adjust system volume

1. Swipe down from the top edge of any screen, and tap . Or go to Settings

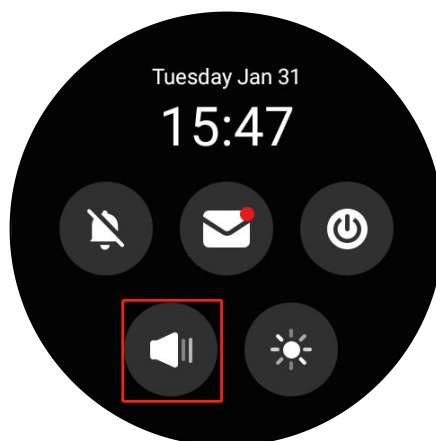

 > Sounds > Systems.

2. Do any of the following to adjust the volume:

- Drag the slider on the touch screen.
- Rotate the outer rim.





If you want to mute all calls and notifications, see [Set up Do Not Disturb](#) chapter in this guide.

Set up Do Not Disturb

If you do not want to be disturbed by calls or notifications, you can turn on the Do Not Disturb (DND) feature. In this case, except for the alarm clock and alerts, you will not hear any call or notification sound.

Quickly turn DND on or off

You can manually turn the DND feature on by swiping down from the top edge of any screen, and tapping . The icon will turn to  when the DND is on. Tap the icon again to turn the DND off.

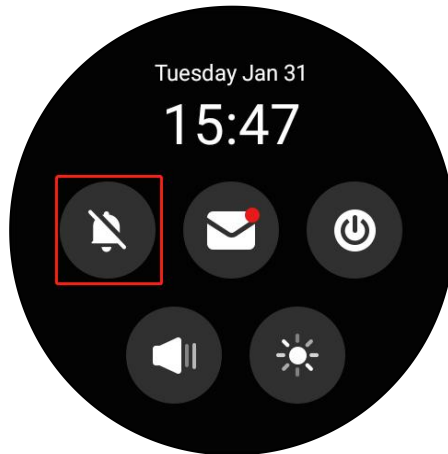

Schedule the DND to turn on automatically

To schedule a DND to turn on automatically at certain times, do as the following:

1. Go to **Settings**  > **DND**.
2. Move the toggle next to **Specific Time** to on.



3. Set the DND start time and end time.

Once you set the times, all the calls and notifications will be silenced in this period.



Protect your HyPanel Lux

For better security, use screen lock or settings lock to prevent unintended access to your device or the settings screen.

Set up screen lock

1. Go to Settings  > System Lock > Screen Lock.
2. Toggle on Screen Lock, and follow the onscreen instructions to set up a pattern

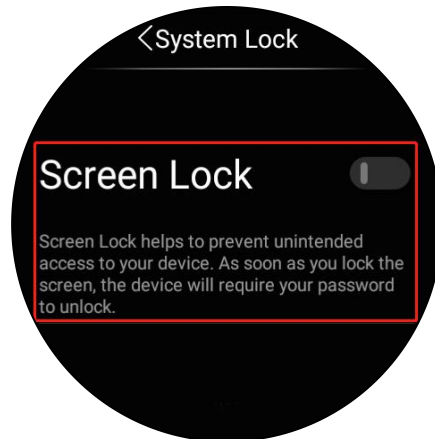

password.

The device will require your password to unlock before you can operate.

Set up settings screen lock

Use the settings lock to prevent unwanted access to the Settings screen .

1. Go to Settings  > System Lock > Settings Lock.
2. Toggle on Settings Lock, and follow the onscreen instructions to set up a pattern



password.

NOTE:

The Screen Lock and the Settings Lock share a same pattern password. When both of the locks are enabled, you only need to unlock the screen so you can access both the device and the Settings screen.

If you forget the password, on the password required screen, tap *Forgot Password* at the bottom, or go to **Settings > System Lock > Set Screen Lock Password > Forgot Password**, and follow the onscreen instructions.

Use HyPanel Lux without Cloud connectivity

You can use the devices without connecting to Akubela Cloud by switching the connection mode to the Off-Cloud mode. In the Off-Cloud mode, all data is saved to the devices instead of the cloud backup, helping to better protect your privacy and enhance your data security.

You should also note that in the Off-Cloud mode, all devices within your family can not receive updates pushed by the cloud server. And your BelaHome app must connect to the local network to use the smart home functions.

To turn on the Off-Cloud mode on user web portal, see [here](#).

Manage Devices

You can manage and control devices directly on the HyPanel Lux.

NOTE:

If your HyPanel Lux is the home center, you can see and control all devices within the family on it. Otherwise, you can only see and control the devices added to the HyPanel Lux.

Add Zigbee Devices

HyPanel Lux can connect to many Zigbee devices, such as sensors, emergency button, and more. For example, you can add and fit a CO sensor in your kitchen to identify carbon monoxide leaks.





NOTE:



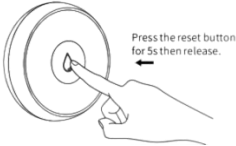

The transmission distances of Zigbee signal may vary by environmental characteristics and more. We recommend using Zigbee sensors, buttons, and switches, which send their commands to HyPanel Lux, mainly in the same room HyPanel Lux is in.

Put Devices in pairing mode

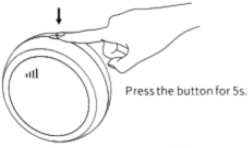
Before pairing the Zigbee devices with the HyPanel Lux, you should know how to put them in the pairing mode.

To put devices not listed below in pairing mode, you can refer to their manuals.

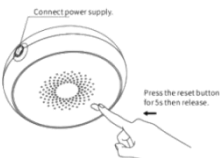
Zigbee device	How to put it to the pairing mode	
<p>Smart</p>  <p>Emergency Button</p>	<p>Insert a pin into the reset hole at its back cover for 5 - 10s until the green light flashes quickly.</p>	
<p>Smart Flood Sensor</p> 	<p>Press and hold the reset button on the front for 5 - 10s until the green light flashes quickly.</p>	
<p>Smart Temperature and Humidity sensor</p> 	<p>Press and hold the reset button on the side for 5 - 10s until the signal icon flashes quickly.</p>	

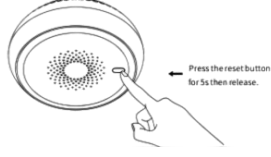
<p>Smart Motion Sensor</p> 	<p>1. Rotate the battery cover anticlockwise to open.</p> <p>2. Press and hold the reset button for at least 5s until the green light flashes quickly.</p>	
<p>Smart Gas Sensor</p> 	<p>Press and hold the reset button on the front for at least 5s until the green light flashes quickly.</p>	
<p>Smart Smoke Sensor</p> 	<p>Press and hold the reset button on the front for at least 5s until the green light flashes quickly.</p>	

Pair devices with HyPanel Lux

1. Go to Settings  > Add device. HyPanel Lux will search for the nearby devices.



2. Put the Zigbee device you want to add in pairing mode.

3. The screen displays the searched device. Tap it to go to the next step.

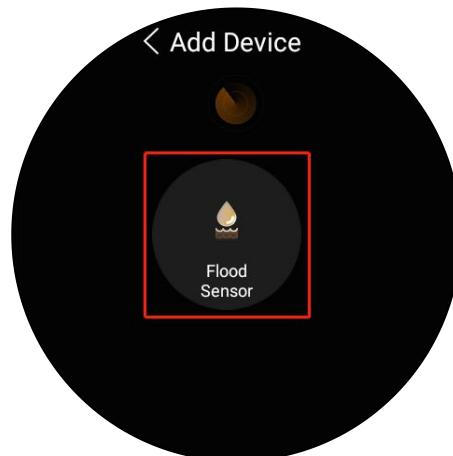

4. Name the device and choose its location, tap OK > OK.

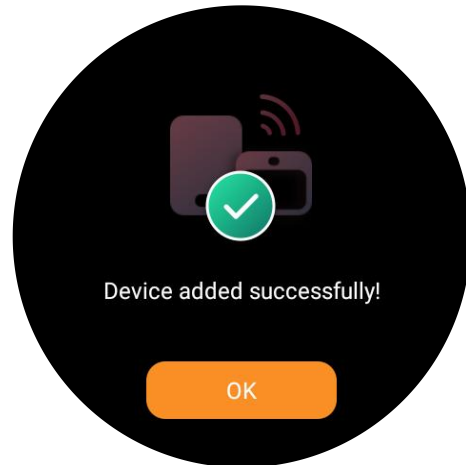

5. The newly added device will be showed on All Devices screen.



You can also see [here](#) to learn more about how to add Zigbee devices from user web portal.

Add third-party smart home devices



Third-party smart home devices, such as Philips Hue, Ring Video Doorbell, Ecobee thermostat, Lutron Caseta, TP-Link kasa, Sonos, and more, can be added from user web portal, or via BelaHome App.

See [here](#) to learn how to add popular smart home devices on user web portal.

See device information

HyPanel Lux allows you to see all the added devices and check their information, including their connection status and locations.

Check if the device is connected

1. Go to Devices , and find the desired device.
2. Check the status icon next to the device name. The online devices have a green icon  next to their names. When the icon is orange , it means the device is offline and can not function.



When a device goes online or offline, your HyPanel Lux will receive a notification. To

see this kind of notification, swipe down from the top edge of any screen, and tap



See where the device is located

Go to **Devices** , and find the desired device. The location where a device is installed is showed at the screen's bottom.



Filter devices by locations

You can see the device list in each room easily by using the filter.

1. Go to **Devices** , and tap the room name at the bottom of the screen.



2. Select the desired location from the room list.



Add devices to Favorites

The Favorites feature enables you to quickly find and control your frequently-used devices. Follow the steps below to access, view, or modify your

Favorites for devices:

1. Go to Devices .



2. Find the desired device, and tap the heart icon next to its name to light it up.

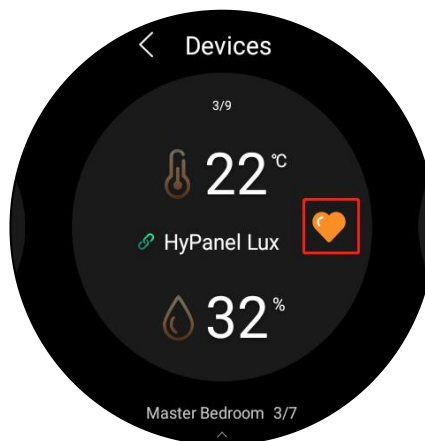

3. The device will appear on the Home screen. Tap it then you can go to its details screen directly.

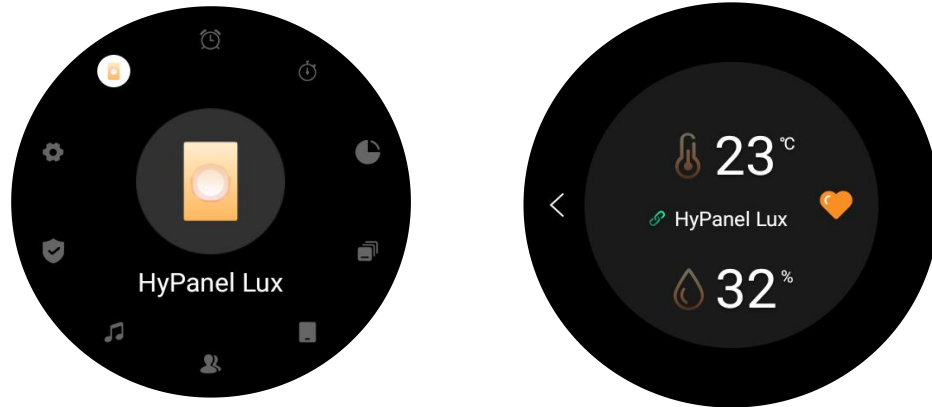

To remove it from the Home screen, just tap the heart icon again.

Customize the All Devices screen

Rearrange the devices

You can rearrange your devices to have them display in the order you want.

1. Go to Devices .
2. Touch and hold the desired device until it becomes smaller and begin to jiggle.

Drag the device to the place you want.

Reorder the room list

If you prefer your rooms in alphabetical order, or in the order you choose them as a routine, do as the following to rearrange them.

1. Go to Devices , and tap the room name at the bottom of the screen.



2. On the followed screen, hold, drag, and drop the rooms in the order you want them to.

Control devices

Control relays

HyPanel Lux supports for directly wiring 2 devices, e.g., 2 lights, to its flush mounted module. These two devices are displayed as Relays on the All Devices screen.

- *Turn relays on or off with a tap*

You can control the relays from Devices screen or by the physical buttons.

To open a relay, go t the the Devices screen and tap it. Its background turns to be highlighted, indicating that the relay is opened.



To close the relay, tap it again, and its background dims.

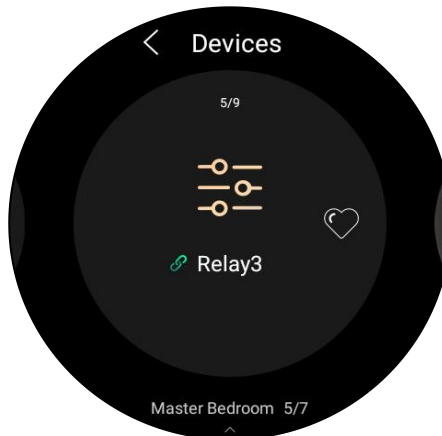

- ***Control relays by physical buttons***

You can press the four physical buttons to control the added relays directly.

No matter whether your HyPanel Lux is installed horizontally or vertically, the two

buttons on the top are to control Relay 1, and the rest two at the bottom are for Relay 2.

Control sockets

To turn on your smart socket, on Devices screen, tap the socket. Its background becomes highlighted, indicating that it has the power.

To cut the socket's power, tap it again, and its background dims.



Control door locks

You can control any connected smart door locks, such as the Yale lock.

On Devices screen, tap the desired smart lock. The lock will be highlighted to indicate



that the lock is open. Tap it again and the image will be back to dimmed, indicating that the lock is closed.

Home Automation

Scenes lets you control your smart devices based on an action, an event, a schedule, or with a simple tap. For example, automatically turn off the light when you leave, and play the music when you're back home.

NOTE:



Before you can automate your home devices using Scenes feature, you need to create scenes on the user web portal. You can also edit and delete scenes, and see related logs on this online website. For a detailed instruction, see [Create and manage automation scenes](#).

Activate your scene

Automation scene types

The Scenes screen displays all scenes within the family.

The following are three types of automation scene and their symbols:

- A scene with auto condition(s) : it can be activated based on a schedule or an event.
 - If the icon is orange , it means the scene will auto-run when its

preset conditions are met.

- *If the icon is white , it means the scene cannot auto-run even if the conditions are met. You can tap the icon to enable its auto-run feature.*

- *A scene with the manual condition: is a scene set to be activated based on a tap or click on the scene image. This type of scene has no additional symbol.*

- *A scene with both auto and manual conditions: a scene based on a schedule, an event, and a tap or click. When any of the conditions is met, the scene will be activated. This type of scene also has an icon  at the bottom.*

Run a scene with manual activation conditions

On the Scenes screen, to activate a scene with manual conditions, just tap it. Its background will be highlighted and then back to be dimmed to show that the scene is activated.

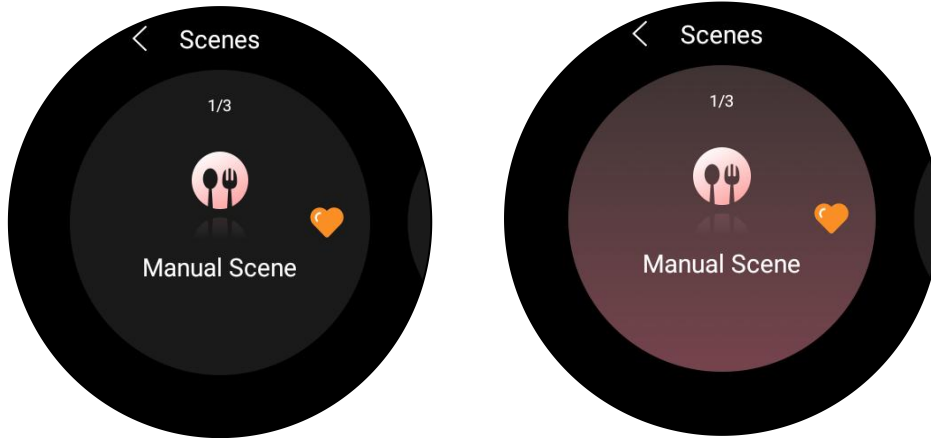

Run a scene with time or action conditions

You do not have to do anything to run an auto scene. Once the preset conditions are met, the scene is activated automatically.

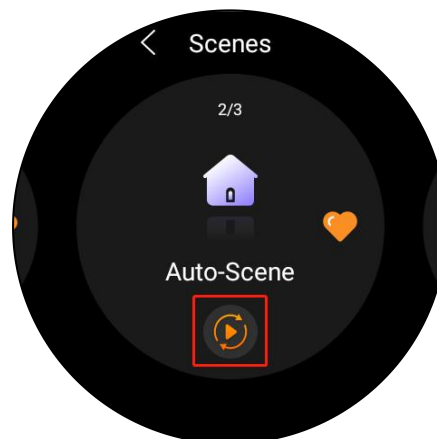

Customize the Scenes screen

You can rearrange your scenes to have them display in the order you want.

1. *Go to Scenes* .
2. *Touch and hold the desired scene until it becomes smaller and begin to jiggle.*

Drag and drop the device to the place you want.

Add Scenes to Favorites

You are enabled to add your frequently-used scenes to Favorites, so you can quickly find and run them.

To favorite a scene, do as the following:

1. *Go to Scenes* .
2. *Find the desired scene, and tap the heart icon next to its name to light it up.*



3. The device will display on the Home screen. Tap it then you can go to its details



screen directly.



To remove it from the Home screen, just tap the heart icon again.

Security

Security modes are used to safeguard your home. You can easily arm, disarm, and control your system using security modes. When you're away, you can put your system in Away mode to safeguard your home. And when you are at home, change the mode to Home mode.

NOTE:

You need to configure three default security modes, or create custom modes on the user web portal before the feature can function properly. You can also modify and delete them on the online website. For detailed instructions, see [Create and manage security modes](#) in the Appendix.

Arm your home

You need to set up default security modes or create your own modes on the user web portal so that you can arm your system.

To arm your home, do as the following:

1. On the Home screen, select Security , then tap the mode you want.

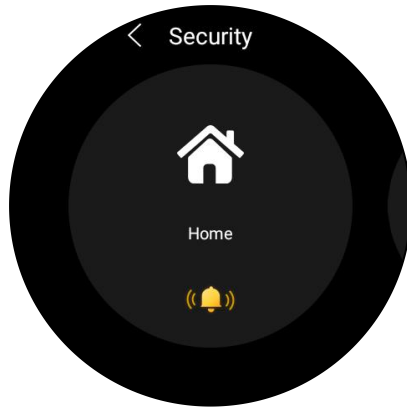

2. Enter the arming code (by default is 0000).

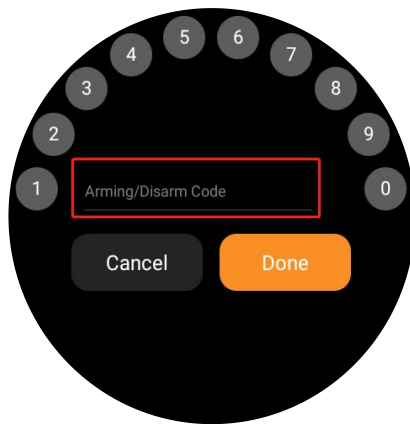

3. Wait for the arming count down to the end. Or tap *Skip* to arm your system right away.

NOTE:

The arming delay time can be modified on the user web portal.

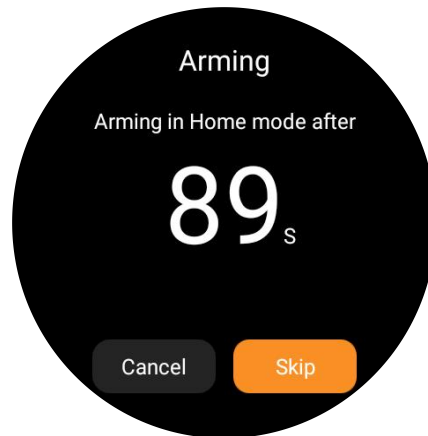

4. Once the system is armed, the selected security mode is highlighted.



Disarm your system

To disarm your system, tap the highlighted mode again, and enter the disarm code which is 0000 by default. You'll know the system is disarmed when the mode turns back to be black.

Deal with an alarm push

When your system is armed in a security mode and any included sensor triggered, the system will push an alarm to the panel and BelaHome app.

To stop the alarm once you make sure your home and family are safe, tap **Disarm** and enter the code (By default is 0000). Your system is still armed in the security mode after the alarm is dealt with.



Disable alarm siren and alarm push

By default, your HyPanel Lux sounds the siren and push the alarm when a sensor in the mode is triggered. You can silence the siren and ban the alert push on the panel.

To make the alert silent, do as the following:

1. Find the desired security mode, and tap .



2. Enter the code which by default is 0000.

3. The siren feature is disabled when you see the icon turns to .



To enable the siren, tap , and enter the preset code.

See the alarm logs

To see the alarm logs, swipe down from the top edge of any screen, tap , and swipe left to the alarm log screen. All security modes' activating logs and alarming logs generated by sensors display here.

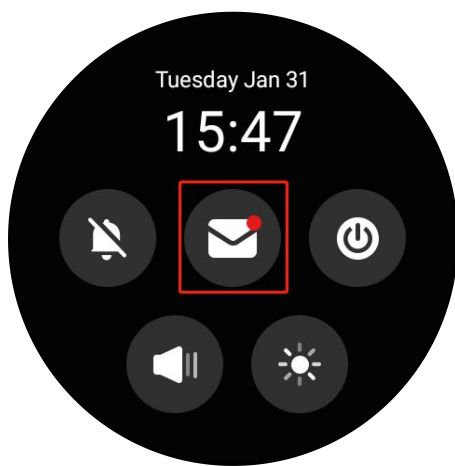

Lighting

Turn a light on or off

On the All Devices screen, select the light you want to control. Tap  to turn the light on. To turn it off, tap this icon again.





Make the light brighter or dimmer

1. On Devices screen, select the light you want to control.
2. Tap , then drag the slider directly or rotating the outer rim to adjust the brightness.



Change the light color

- 1. On Devices screen, select the desired light.*
- 2. Tap , pick the color you like from the palette, then tap .*





Make the light color warmer or cooler

You can adjust your light color temperature. Color temperature refers to how warm

or cool the light is.

1. On Devices screen, select the desired light.

2. Tap , adjust the slider, then tap .



Environment

Comfort

Change Ecobee mode



Use HyPanel Lux to switch Ecobee modes. On the Devices screen, tap your Ecobee device once to switch the current mode to the next.



Timer and alarm clock

Set the timer

Use the countdown timer as a reminder.

1. On the Home screen, select **Timer** . The Timer screen opens.
2. Set the duration of time, then tap **Start** .

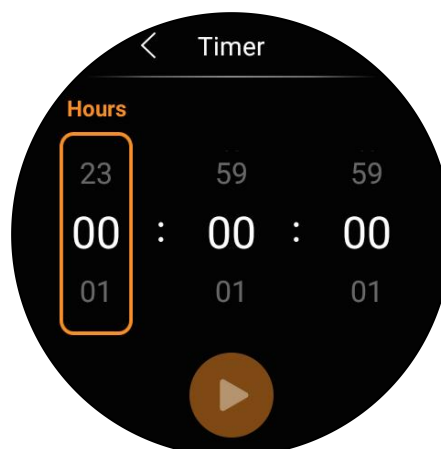

3. To stop the running timer, on the countdown screen:

- Tap  to pause the timer.
- Tap  to cancel the timer.



When a timer finishes, tap  to go back to the previous screen. To restart it, tap



Set an alarm clock

You can set a alarm clock to wake you up, or to remind you to do something. The alarm cannot be silenced in the DND period.

Set an alarm

1. On the Home screen, select Alarm Clock .



2. Tap  at the bottom.

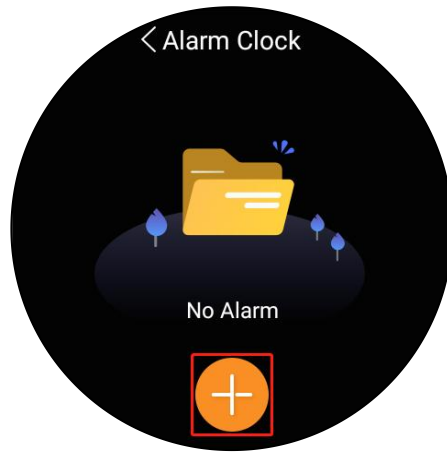

3. Rotate the outer rim to set the time, and tap .

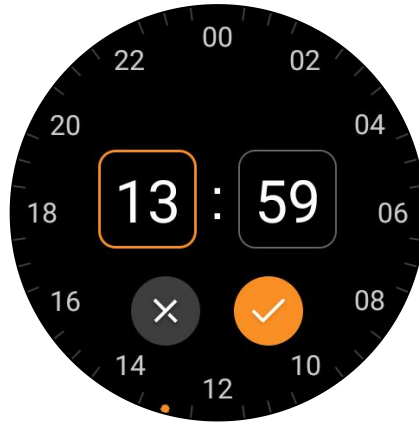

4. Choose any of the following options, and tap  at the bottom to save it.

- Repeat: Choose the days of the week.
- Sound: Choose a ringtone.
- Snooze: To delay the alarm for a few minutes.



To cancel an alarm, on Alarm screen, move the toggle next to the alarm time.

Change or remove an alarm clock

1. Go to Alarm Clock , and tap the alarm you want to edit.



2. On the Edit Alarm screen, do any of the following:

- Change the preset time.
- Change the repeat option.
- Change the sound.
- Turn the snooze on or off.
- Delete the alarm clock.

Snooze or stop an alarm

When your alarm rings, do one of the following:

- Tap **Snooze for 10 minutes** to delay the alarm for 10 minutes.
- Slide to turn off the alarm.

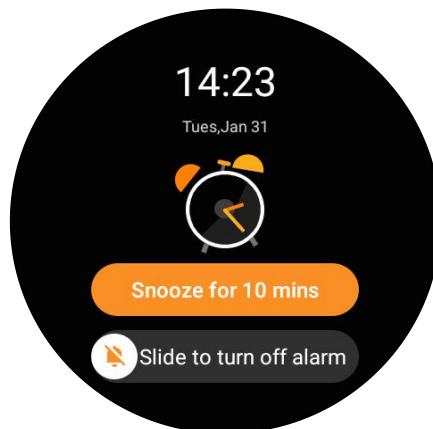

Energy

Use the Energy feature to track the power consumption of your devices, rooms, and whole home.

NOTE:

The Energy feature only applies to smart devices that support energy data collection.

1. On the Home screen, select Energy .
2. The Energy screen by default displays yesterday's data:
 - The whole home power usage data is in the center of the circle.
 - Top 3 power consumers.
 - The rest of rooms' total energy consumption.

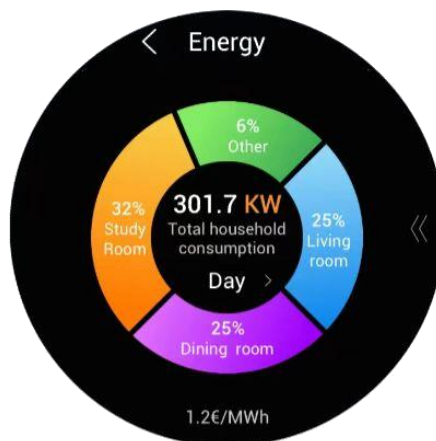

3. To see energy consumption of last week, or last month, tap  next to Day.



4. To track each room's power usage, swipe up from the bottom of the screen. The details screen opens.



5. To track each device's power usage in a room, tap the specific room.



Use the intercom

Unlock the door remotely

When someone you are waiting for rings the door, you can unlock the door directly on HyPanel Lux without having to rush to the intercom.

1. Go to **Devices** , and find the desired door phone.
2. Tap the door phone to open the door.



Unlock the door before answering a call

When receiving a call from the door phone, you will see its monitoring stream if it has a camera.

On the preview screen, tap  to open the door.



Unlock the door during a call

When answering a call from the door phone, you can unlock the door during the call.

On the talking screen, tap  to release the door.



You are also able to call the door phone to see and hear who the visitor is. To do so, see the section [Make one-to-one voice calls](#) in this guide.

Communication in Family

You and your family members can make calls with each other, and send and receive messages anytime through HyPanel Lux.



Family Accounts

If you are the administrator in the family, you are allowed to log in to the user web portal to manage family member accounts and more. To create and manage family accounts from user web portal, see [Family accounts management](#).

You can also create and manage family accounts via BelaHome app.

Make one-to-one voice calls

You can call with or receive calls from any devices including the door phones or family member's through HyPanel Lux. To make calls, do as the following:

1. Tap  on the lock screen, or tap  on the Home screen to go to Contacts screen.
2. Select the desired family member or device.

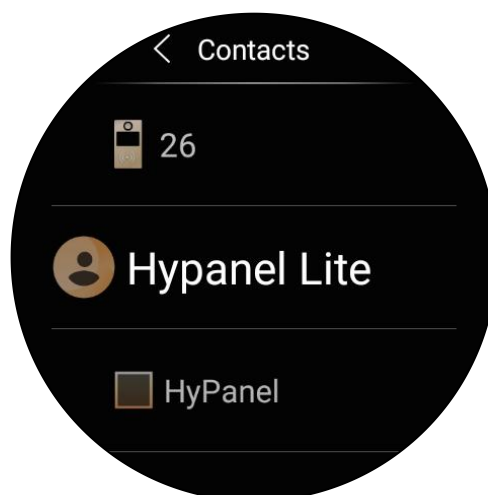



3. On the conversation screen, tap .



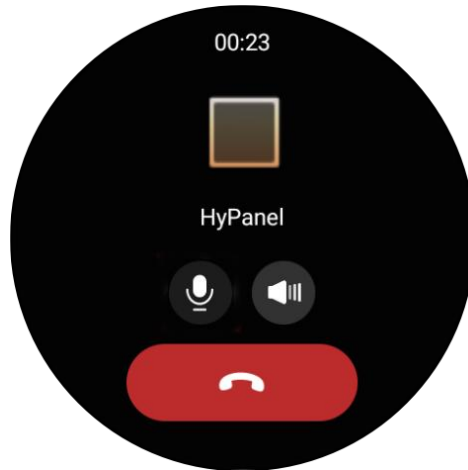

What else you can do on the voice call screen:



- Tap  to silence your microphone, so the called will not hear your voice.
- Tap  to adjust the volume.
- Tap  to hang up the call.

Send audio messages

HyPanel Lux allows you to send and receive voice messages.

1. Tap  on the lock screen, or tap  on the Home screen to go to Contacts screen
2. Select the desired member or device.
3. In the conversation, tap and hold  at the bottom right to record an audio message. Each message should be within 30 seconds.

To cancel before sending, slide your finger to the left while you are recording.

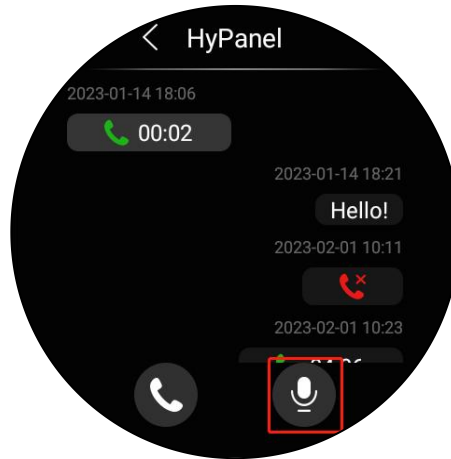

4. Lift your finger to send the message.

See text messages

HyPanel Lux allows you to see text messages sent from BelaHome App or SmartPanels. However, you cannot send text messages through HyPanel Lux.

To see received text message, go to Contacts screen, and select the contact. In the conversation screen, you can see all the messages list there.

Update, Restart, and Reset

Update the system

To update HyPanel Lux to the latest version, go to **Settings**  > **Update**. On the Update screen, do any of the following:

- Toggle on **Auto Update** to update the firmware automatically. If an update is available, HyPanel Lux downloads and installs it automatically.

NOTE:

When Auto Update is off, the system will push the available update to the device. The device installs the update only when you agree to.

- Tap **Update** to manually update the system when the latest version is available.

NOTE:

If your system already installs the latest version, the screen shows no Update button.



Restart your HyPanel Lux

To restart the device's system, do any of the following:

- Poke the reset hole at the short side edge (as shown in the picture) with a paperclip or needle for about 3 seconds until the display turns off.



- Go to **Settings**  > **Reboot&Reset** > **Reboot**.

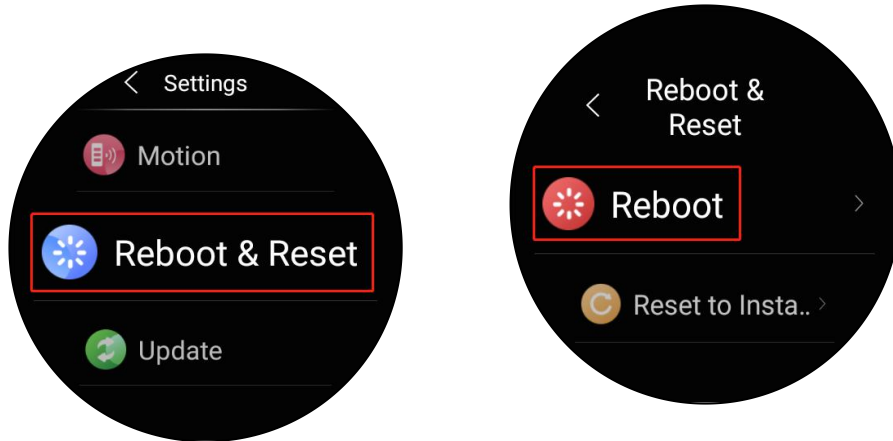

Restore HyPanel Lux to installer settings

You can restore HyPanel Lux to the settings that are configured by your installer.

Once restored, all the user data generated after the installation, such as the data stored on the device, the sub-devices you added to the panel, and more, is cleared.

- 1. On the Home screen, select Settings by tapping the icon .*
- 2. Go to Reboot&Reset > Reset to Installer Setting.*

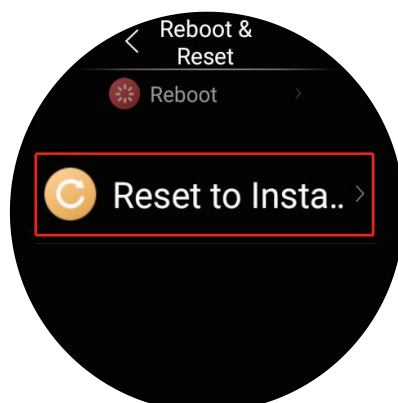

Privacy Policy

As you use our services, you're trusting us with your information. We keep working hard to protect your data. The Privacy Policy is meant to help you be clear about what information we collect, why we collect it, and how you can protect your privacy.

To read the Privacy Policy, do as the following:

- 3. On the Home screen, select Settings by tapping the icon .*
- 4. Go to About > Privacy Agreement.*

Get Help

For videos and other manuals, visit <https://knowledge.akuvox.com>.

For help, contact us at <https://ticket.akuvox.com>

Important Notices

Wireless Communication Function

5 GHz band (W52, W53): Indoor use only

FCC Caution:

Any Changes or modifications not expressly approved by the party responsible for compliance could void the user's authority to operate the equipment.

This device complies with part 15 of the FCC Rules. Operation is subject to the following two conditions: (1) This device may not cause harmful interference, and (2) this device must accept any interference received, including interference that may cause undesired operation.

FCC Radiation Exposure Statement:

This equipment complies with FCC radiation exposure limits set forth for an uncontrolled environment. This equipment should be installed and operated with minimum distance 20cm between the radiator& your body.

This transmitter must not be co-located or operating in conjunction with any other antenna or transmitter.

Note: This equipment has been tested and found to comply with the limits for a Class B digital device, pursuant to part 15 of the FCC Rules. These limits are designed to provide reasonable protection against harmful interference in a residential installation. This equipment generates uses and can radiate radio frequency energy and, if not installed and used in accordance with the instructions, may cause harmful interference to radio communications. However, there is no guarantee that interference will not occur in a particular installation. If this equipment does cause harmful interference to radio or television reception, which can be determined by turning the equipment off and on, the user is encouraged to try to correct the interference by one or more of the following measures:

- Reorient or relocate the receiving antenna.
- Increase the separation between the equipment and receiver.
- Connect the equipment into an outlet on a circuit different from that to which the receiver is connected.