



# FCC Part 15C Test Report

## FCC ID: 2AHCNLOCK100

Product Name:	<b>Wireless Router</b>
Trademark:	<b>Tosibox</b>
Model Name :	<b>Lock 100</b>
Prepared For :	<b>Tosibox Oy</b>
Address :	<b>Elektroniikkatie 10,90590 OULU,FINLAND</b>
Prepared By :	<b>Shenzhen BCTC Technology Co., Ltd.</b>
Address :	No.101,Yousong Road,Longhua New District, Shenzhen,China
Test Date:	<b>Dec. 24- Dec. 31, 2015</b>
Date of Report :	<b>Dec. 31, 2015</b>
Report No.:	<b>BCTC-151114336</b>



### TEST RESULT CERTIFICATION

**Applicant's name**..... : Tosibox Oy

Address..... : Elektriikkatie 10,90590 OULU,FINLAND

**Manufacture's Name**..... : **Shenzhen Century Xinyang Tech Co., Ltd**

Address..... : B402 Room B402, Zhongdi Building China University of Geosciences Base, No. 8 Yuexing 3rd Road, South of High-Tech Industrial Park, Nanshan Distric, Shenzhen Guangdong,518057, CN

**Product description**

Product name..... : Wireless Router

Model and/or type reference : Lock 100

Serial Model..... : Tosibox

**Standards**..... : FCC Part15.247

Test procedure..... ANSI C63.10-2013

This device described above has been tested by BCTC, and the test results show that the equipment under test (EUT) is in compliance with the FCC requirements. And it is applicable only to the tested sample identified in the report.

This report shall not be reproduced except in full, without the written approval of BCTC, this document may be altered or revised by BCTC, personal only, and shall be noted in the revision of the document.

Testing Engineer : Eric Yang  
(Eric Yang)

Technical Manager : Sophie Lu  
(Sophia Lee)

Authorized Signatory : Carson Zhang  
(Carson. Zhang)



**Table of Contents**

	<b>Page</b>
<b>1 . SUMMARY OF TEST RESULTS</b>	<b>5</b>
1.1 TEST FACILITY	6
1.2 MEASUREMENT UNCERTAINTY	6
<b>2 . GENERAL INFORMATION</b>	<b>7</b>
2.1 GENERAL DESCRIPTION OF EUT	7
2.2 DESCRIPTION OF TEST MODES	9
2.3 BLOCK DIGRAM SHOWING THE CONFIGURATION OF SYSTEM TESTED	10
2.4 DESCRIPTION OF SUPPORT UNITS(CONDUCTED MODE)	11
2.5 EQUIPMENTS LIST FOR ALL TEST ITEMS	12
<b>3 . EMC EMISSION TEST</b>	<b>13</b>
3.1 CONDUCTED EMISSION MEASUREMENT	13
3.1.1 POWER LINE CONDUCTED EMISSION LIMITS	13
3.1.2 TEST PROCEDURE	14
3.1.3 DEVIATION FROM TEST STANDARD	14
3.1.4 TEST SETUP	14
3.1.5 EUT OPERATING CONDITIONS	14
3.1.6 TEST RESULTS	15
3.2 RADIATED EMISSION MEASUREMENT	17
3.2.1 RADIATED EMISSION LIMITS	17
3.2.2 TEST PROCEDURE	18
3.2.3 DEVIATION FROM TEST STANDARD	18
3.2.4 TEST SETUP	19
3.2.5 EUT OPERATING CONDITIONS	20
3.2.6 TEST RESULTS (BETWEEN 9KHZ – 30 MHZ)	21
3.2.7 TEST RESULTS (BETWEEN 30MHZ – 1GHZ)	22
3.2.8 TEST RESULTS (ABOVE 1000 MHZ)	24
<b>4 . POWER SPECTRAL DENSITY TEST</b>	<b>46</b>
4.1 APPLIED PROCEDURES / LIMIT	46
4.1.1 TEST PROCEDURE	46
4.1.2 DEVIATION FROM STANDARD	46
4.1.3 TEST SETUP	46
4.1.4 EUT OPERATION CONDITIONS	46
4.1.5 TEST RESULTS	47



<b>Table of Contents</b>	<b>Page</b>
<b>5 . BANDWIDTH TEST</b>	<b>55</b>
<b>5.1 APPLIED PROCEDURES / LIMIT</b>	<b>55</b>
5.1.1 TEST PROCEDURE	55
5.1.2 DEVIATION FROM STANDARD	55
5.1.3 TEST SETUP	55
5.1.4 EUT OPERATION CONDITIONS	55
5.1.5 TEST RESULTS	56
<b>6 . PEAK OUTPUT POWER TEST</b>	<b>64</b>
<b>6.1 APPLIED PROCEDURES / LIMIT</b>	<b>64</b>
6.1.1 TEST PROCEDURE	64
6.1.2 DEVIATION FROM STANDARD	64
6.1.3 TEST SETUP	64
6.1.4 EUT OPERATION CONDITIONS	64
6.1.5 TEST RESULTS	65
<b>7 . 100 KHZ BANDWIDTH OF FREQUENCY BAND EDGE</b>	<b>66</b>
7.1 DEVIATION FROM STANDARD	66
7.2 TEST SETUP	67
7.3 EUT OPERATION CONDITIONS	67
7.4 TEST RESULTS	68
<b>8 . DUTY CYCLE OF TEST SIGNAL</b>	<b>73</b>
8.1 STANDARD REQUIREMENT	73
8.2 FORMULA:	73
<b>9 . ANTENNA REQUIREMENT</b>	<b>74</b>
9.1 STANDARD REQUIREMENT	74
9.2 EUT ANTENNA	74
<b>10 . EUT TEST PHOTO</b>	<b>75</b>
<b>11 . EUT PHOTO</b>	<b>77</b>
<b>APPENDIX-PHOTOGRAPHS OF EUT CONSTRUCTIONAL DETAILS</b>	



## 1. SUMMARY OF TEST RESULTS

Test procedures according to the technical standards:

<b>FCC Part15 (15.247) , Subpart C</b>			
Standard Section	Test Item	Judgment	Remark
15.207	Conducted Emission	PASS	
15.247 (a)(2)	6dB Bandwidth	PASS	
15.247 (b)	Peak Output Power	PASS	
15.247 (c)	Radiated Spurious Emission	PASS	
15.247 (d)	Power Spectral Density	PASS	
15.205	Band Edge Emission	PASS	
15.203	Antenna Requirement	PASS	

**NOTE:**

(1) "N/A" denotes test is not applicable in this Test Report



## 1.1 TEST FACILITY

Shenzhen BCTC Technology Co., Ltd.

Add. : No.101, Yousong Road, Longhua New District, Shenzhen, China

FCC Registered No.: 187086

## 1.2 MEASUREMENT UNCERTAINTY

The reported uncertainty of measurement  $y \pm U$ , where expanded uncertainty  $U$  is based on a standard uncertainty multiplied by a coverage factor of  $k=2$ , providing a level of confidence of approximately **95 %**.

No.	Item	Uncertainty
1	Conducted Emission Test	$\pm 1.38\text{dB}$
2	RF power, conducted	$\pm 0.16\text{dB}$
3	Spurious emissions, conducted	$\pm 0.21\text{dB}$
4	All emissions, radiated (<1G)	$\pm 4.68\text{dB}$
5	All emissions, radiated (>1G)	$\pm 4.89\text{dB}$
6	Temperature	$\pm 0.5^\circ\text{C}$
7	Humidity	$\pm 2\%$



## 2. GENERAL INFORMATION

### 2.1 GENERAL DESCRIPTION OF EUT

Equipment	Wireless Router	
Trade Name	Tosibox	
Model Name	Lock 100	
Serial Model	N/A	
Model Difference	N/A	
Product Description	The EUT is a Wireless Router	
	Operation Frequency:	802.11b/g/n20MHz:2412~2462 MHz 802.11n40MHz:2422~2452 MHz
	Modulation Type:	802.11b: DSSS (CCK, DQPSK, DBPSK) 802.11g/n(20/40): DSSS (CCK, DQPSK,DBPSK)+OFDM (QPSK, BPSK, 16-QAM, 64-QAM)
	Bit Rate of Transmitter	802.11b: 11/5.5/2/1Mbps 802.11g: 6Mbps, 9Mbps, 12Mbps, 18Mbps, 24Mbps, 36Mbps, 48Mbps,54Mbps 802.11n: Up to 150Mbps
	Number Of Channel	802.11b/g/n20MHz:11CH 802.11n40MHz:7CH
	Antenna Designation:	Please see Note 3.
	Output Power(Conducted,AV):	802.11b: 13.55dBm (Max.) 802.11g: 12.65 dBm (Max.) 802.11n(20M) : 10.67dBm (Max.) 802.11n(40M) : 9.44Bm (Max.)
	Based on the application, features, or specification exhibited in User's Manual, the EUT is considered as an ITE/Computing Device. More details of EUT technical specification, please refer to the User's Manual.	
Channel List	Please refer to the Note 2.	
Adapter	Model:CS-1201000 AC Power Input: 100-240V~ 0.5A 50/60Hz Output: 12V--- 1A	
Connecting I/O Port(s)	Please refer to the User's Manual	

Note:

1. For a more detailed features description, please refer to the manufacturer's specifications or the User's Manual.



2.

Channel List for 802.11b/g/n(20)							
Channel	Frequency (MHz)	Channel	Frequency (MHz)	Channel	Frequency (MHz)	Channel	Frequency (MHz)
01	2412	04	2427	07	2442	10	2457
02	2417	05	2432	08	2447	11	2462
03	2422	06	2437	09	2452		

Channel List for 802.11n(40MHz)							
Channel	Frequency (MHz)	Channel	Frequency (MHz)	Channel	Frequency (MHz)	Channel	Frequency (MHz)
03	2422	06	2437	09	2452		
04	2427	07	2442				
05	2432	08	2447				

3.

Table for Filed Antenna

Ant.	Brand	Model Name	Antenna Type	Connector	Gain (dBi)	NOTE
A	N/A	N/A	Reverse SMA-type antenna	SMA Male	2.0	Wifi Antenna 1
B	N/A	N/A	Reverse SMA-type antenna	SMA Male	2.0	Wifi Antenna 2





## 2.2 DESCRIPTION OF TEST MODES

To investigate the maximum EMI emission characteristics generates from EUT, the test system was pre-scanning tested base on the consideration of following EUT operation mode or test configuration mode which possible have effect on EMI emission level. Each of these EUT operation mode(s) or test configuration mode(s) mentioned above was evaluated respectively.

Pretest Mode	Description
Mode 1	802.11b CH1/ CH6/ CH11
Mode 2	802.11g CH1/ CH6/ CH11
Mode 3	802.11n CH1/ CH6/ CH11
Mode 4	Link Mode

For Conducted Emission	
Final Test Mode	Description
Mode 4	Link Mode

For Radiated Emission	
Final Test Mode	Description
Mode 1	802.11b CH1/ CH6/ CH11
Mode 2	802.11g CH1/ CH6/ CH11
Mode 3	802.11n(20)CH1/ CH6/ CH11
Mode 4	802.11n(40)CH3/ CH6/ CH9

Note:

- (1) The measurements are performed at the highest, middle, lowest available channels.
- (2)The measurements are performed at all Bit Rate of Transmitter, the worst data was reported



### 2.3 BLOCK DIGRAM SHOWING THE CONFIGURATION OF SYSTEM TESTED

#### Conducted Emission Test

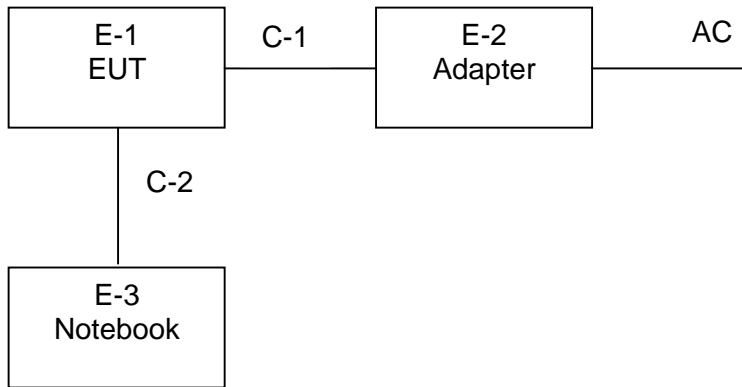

#### Radiated Spurious Emission Test

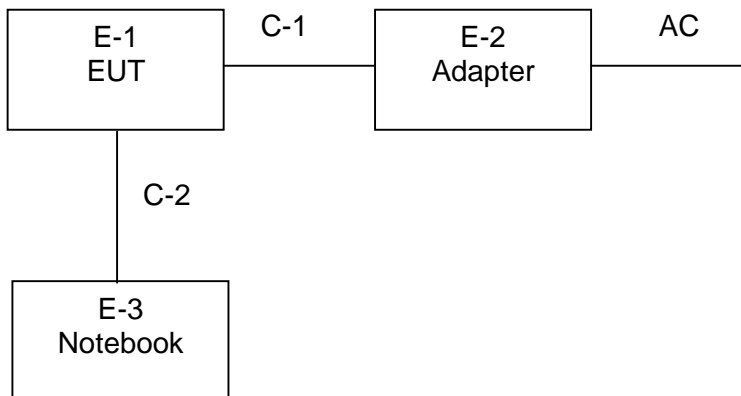



## 2.4 DESCRIPTION OF SUPPORT UNITS(CONDUCTED MODE)

The EUT has been tested as an independent unit together with other necessary accessories or support units. The following support units or accessories were used to form a representative test configuration during the tests.

Item	Equipment	Mfr/Brand	Model/Type No.	Series No.	Note
E-1	Wireless Router	Tosibox	Lock 100	N/A	EUT
E-2	Adapter	N/A	CS-1201000	N/A	AC Input: 100-240V~ 0.5A 50/60Hz Output: 12V $\overline{\text{---}}$ 1A
E-3	Notebook	N/A	X550C	N/A	

Item	Shielded Type	Ferrite Core	Length	Note
C-1	NO	NO	1.0M	DC cable unshielded
C-2	NO	NO	1.2M	Ethernet cable unshielded

Note:

- (1) The support equipment was authorized by Declaration of Confirmation.
- (2) For detachable type I/O cable should be specified the length in cm in 『Length』 column.



## 2.5 EQUIPMENTS LIST FOR ALL TEST ITEMS

### Radiation Test equipment

Item	Kind of Equipment	Manufacturer	Type No.	Serial No.	Last calibration	Calibrated until	Calibration period
1	Spectrum Analyzer	Agilent	E4407B	MY4510957 2	2015.08.25	2016.08.24	1 year
2	Test Receiver	R&S	ESPI	101396	2015.08.25	2016.08.24	1 year
3	Bilog Antenna	SCHWARZBECK	VULB9160	VULB9160- 3369	2015.08.25	2016.08.24	1 year
4	50Ω Coaxial Switch	Anritsu	MP59B	620026441 6	2015.06.07	2016.06.06	1 year
5	Spectrum Analyzer	ADVANTEST	R3132	150900201	2015.06.07	2016.06.06	1 year
6	Horn Antenna	SCHWARZBECK	9120D	9120D-1275	2015.08.25	2016.08.24	1 year
7	Horn Ant	Schwarzbeck	BBHA 9170	9170-181	2015.07.06	2016.07.05	1 year
8	Amplifier	SCHWARZBECK	BBV9718	9718-270	2015.08.25	2016.08.24	1 year
9	Amplifier	SCHWARZBECK	BBV9743	9743-119	2015.08.25	2016.08.24	1 year
10	Loop Antenna	ARA	PLA-1030/B	1029	2015.06.08	2016.06.07	1 year
11	Power Meter	R&S	NRVS	100696	2015.07.06	2016.07.05	1 year
12	Power Sensor	R&S	NRV-Z55	161905	2015.07.06	2016.07.05	1 year
13	RF cables	R&S	N/A	N/A	2015.07.06	2016.07.05	1 year

### Conduction Test equipment

Item	Kind of Equipment	Manufacturer	Type No.	Serial No.	Last calibration	Calibrated until	Calibration period
1	Test Receiver	R&S	ESCI	101421	2015.08.25	2016.08.24	1 year
2	LISN	SCHWARZBECK	NSLK8127	812779	2015.08.25	2016.08.24	1 year
3	LISN	EMCO	Feb-16	42990	2015.08.24	2016.08.23	1 year
4	50Ω Coaxial Switch	Anritsu	MP59B	620026441 7	2015.06.07	2016.06.06	1 year
5	Passive Voltage Probe	R&S	ESH2-Z3	100196	2015.06.07	2016.06.06	1 year



### 3. EMC EMISSION TEST

#### 3.1 CONDUCTED EMISSION MEASUREMENT

##### 3.1.1 POWER LINE CONDUCTED EMISSION Limits (Frequency Range 150KHz-30MHz)

FREQUENCY (MHz)	Class A (dBuV)		Class B (dBuV)		Standard
	Quasi-peak	Average	Quasi-peak	Average	
0.15 -0.5	79.00	66.00	66 - 56 *	56 - 46 *	CISPR
0.50 -5.0	73.00	60.00	56.00	46.00	CISPR
5.0 -30.0	73.00	60.00	60.00	50.00	CISPR

0.15 -0.5	79.00	66.00	66 - 56 *	56 - 46 *	FCC
0.50 -5.0	73.00	60.00	56.00	46.00	FCC
5.0 -30.0	73.00	60.00	60.00	50.00	FCC

Note:

- (1) The tighter limit applies at the band edges.
- (2) The limit of " \* " marked band means the limitation decreases linearly with the logarithm of the frequency in the range.

The following table is the setting of the receiver

Receiver Parameters	Setting
Attenuation	10 dB
Start Frequency	0.15 MHz
Stop Frequency	30 MHz
IF Bandwidth	9 kHz

### 3.1.2 TEST PROCEDURE

- The EUT was placed 0.8 meters from the horizontal ground plane with EUT being connected to the power mains through a line impedance stabilization network (LISN). All other support equipments powered from additional LISN(s). The LISN provide 50 Ohm/ 50uH of coupling impedance for the measuring instrument.
- Interconnecting cables that hang closer than 40 cm to the ground plane shall be folded back and forth in the center forming a bundle 30 to 40 cm long.
- I/O cables that are not connected to a peripheral shall be bundled in the center. The end of the cable may be terminated, if required, using the correct terminating impedance. The overall length shall not exceed 1 m.
- LISN at least 80 cm from nearest part of EUT chassis.
- For the actual test configuration, please refer to the related Item –EUT Test Photos.

### 3.1.3 DEVIATION FROM TEST STANDARD

No deviation

### 3.1.4 TEST SETUP

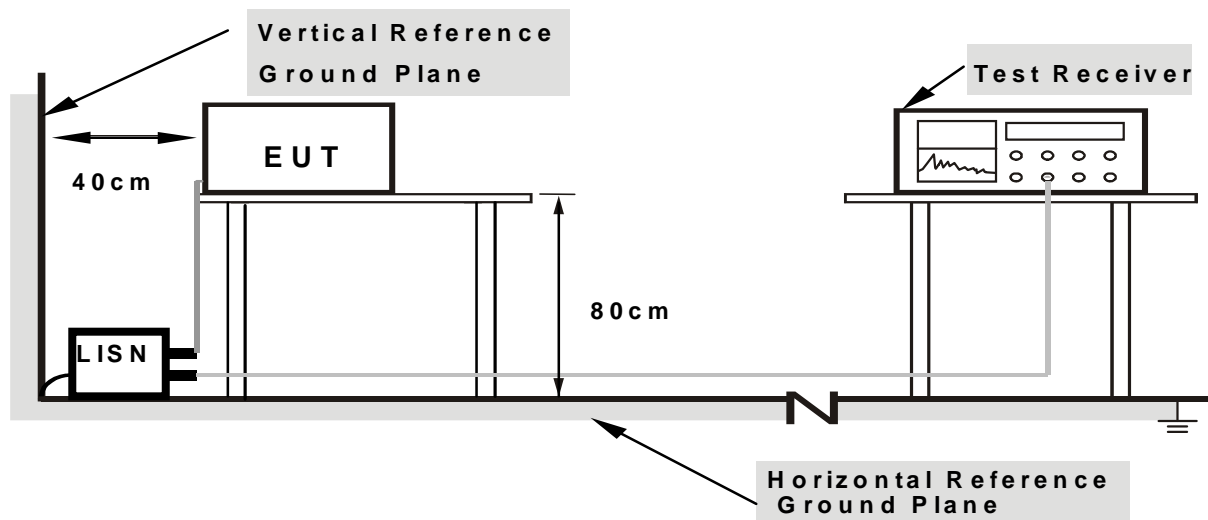

**Note: 1.Support units were connected to second LISN.**

**2.Both of LISNs (AMN) are 80 cm from EUT and at least 80 from other units and other metal planes**

### 3.1.5 EUT OPERATING CONDITIONS

The EUT was configured for testing in a typical fashion (as a customer would normally use it). The EUT has been programmed to continuously transmit during test. This operating condition was tested and used to collect the included data.

We pretest AC 120V and AC 240V, the worst voltage was AC 120V and the data recording in the report.



### 3.1.6 TEST RESULTS

EUT :	Wireless Router	Model Name. :	Lock 100
Temperature :	25°C	Relative Humidity :	54%
Pressure :	1010hPa	Phase :	L
Test Voltage :	AC120V/60Hz	Test Mode :	Link Mode

Frequency (MHz)	Meter Reading (dBμV)	Factor (dB)	Emission Level (dBμV)	Limits (dBμV)	Margin (dB)	Detector Type
0.1740	47.74	10.06	57.80	64.76	-6.96	QP
0.1740	31.33	10.06	41.39	54.76	-13.37	AVG
0.2300	41.32	10.07	51.39	62.45	-11.06	QP
0.2300	24.95	10.07	35.02	52.45	-17.43	AVG
0.4540	37.09	10.11	47.20	56.80	-9.60	QP
0.4540	25.65	10.11	35.76	46.80	-11.04	AVG
0.6419	33.07	10.13	43.20	56.00	-12.80	QP
0.6419	12.63	10.13	22.76	46.00	-23.24	AVG
5.7980	34.00	10.10	44.10	60.00	-15.90	QP
5.7980	15.46	10.10	25.56	50.00	-24.44	AVG
16.9220	39.89	10.16	50.05	60.00	-9.95	QP
16.9220	26.31	10.16	36.47	50.00	-13.53	AVG

Remark:

1. All readings are Quasi-Peak and Average values.
2. Factor = Insertion Loss + Cable Loss.

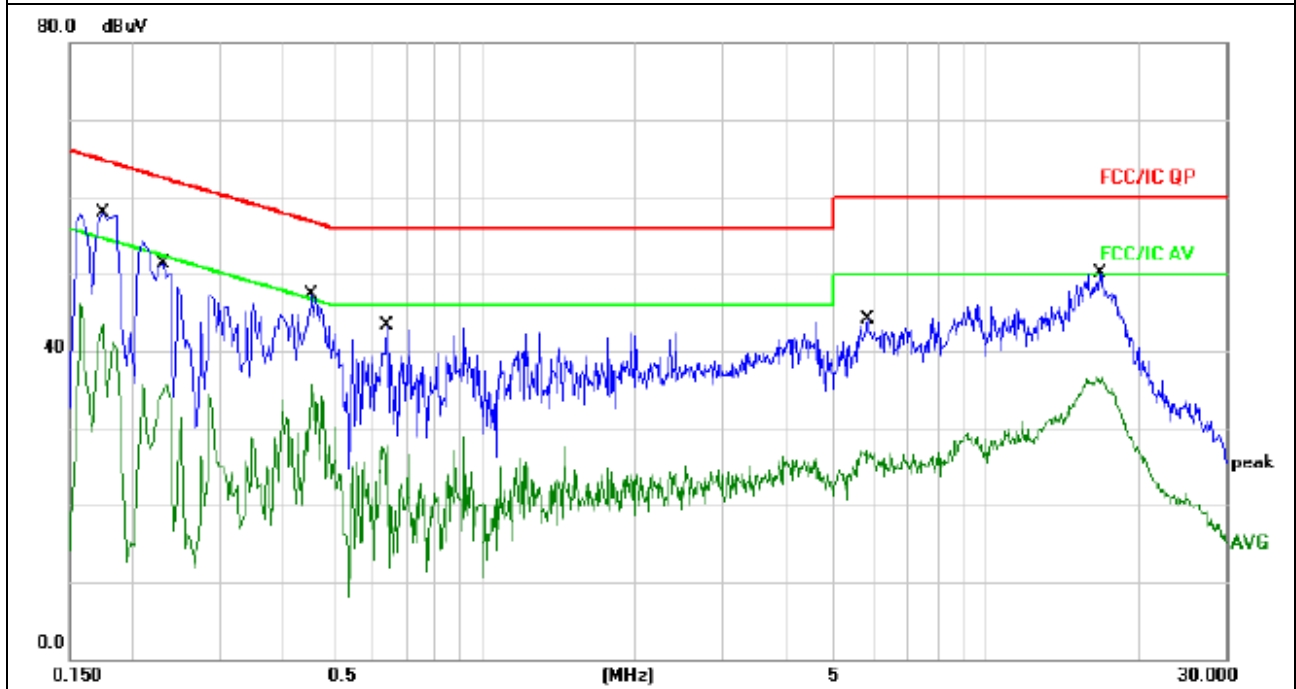



EUT :	Wireless Router	Model Name. :	Lock 100
Temperature :	25°C	Relative Humidity :	54%
Pressure :	1010hPa	Phase :	N
Test Voltage :	AC120V/60Hz	Test Mode :	Link Mode

Frequency (MHz)	Meter Reading (dBμV)	Factor (dB)	Emission Level (dBμV)	Limits (dBμV)	Margin (dB)	Detector Type
0.1580	49.93	10.05	59.98	65.56	-5.58	QP
0.1580	32.45	10.05	42.50	55.56	-13.06	AVG
0.2060	45.74	10.07	55.81	63.36	-7.55	QP
0.2060	30.00	10.07	40.07	53.36	-13.29	AVG
0.4420	38.07	10.11	48.18	57.02	-8.84	QP
0.4420	28.11	10.11	38.22	47.02	-8.80	AVG
0.9540	31.68	10.16	41.84	56.00	-14.16	QP
0.9540	16.79	10.16	26.95	46.00	-19.05	AVG
9.2220	30.98	10.12	41.10	60.00	-18.90	QP
9.2220	19.31	10.12	29.43	50.00	-20.57	AVG
16.8500	39.33	10.16	49.49	60.00	-10.51	QP
16.8500	26.55	10.16	36.71	50.00	-13.29	AVG

Remark:

1. All readings are Quasi-Peak and Average values.
2. Factor = Insertion Loss + Cable Loss.

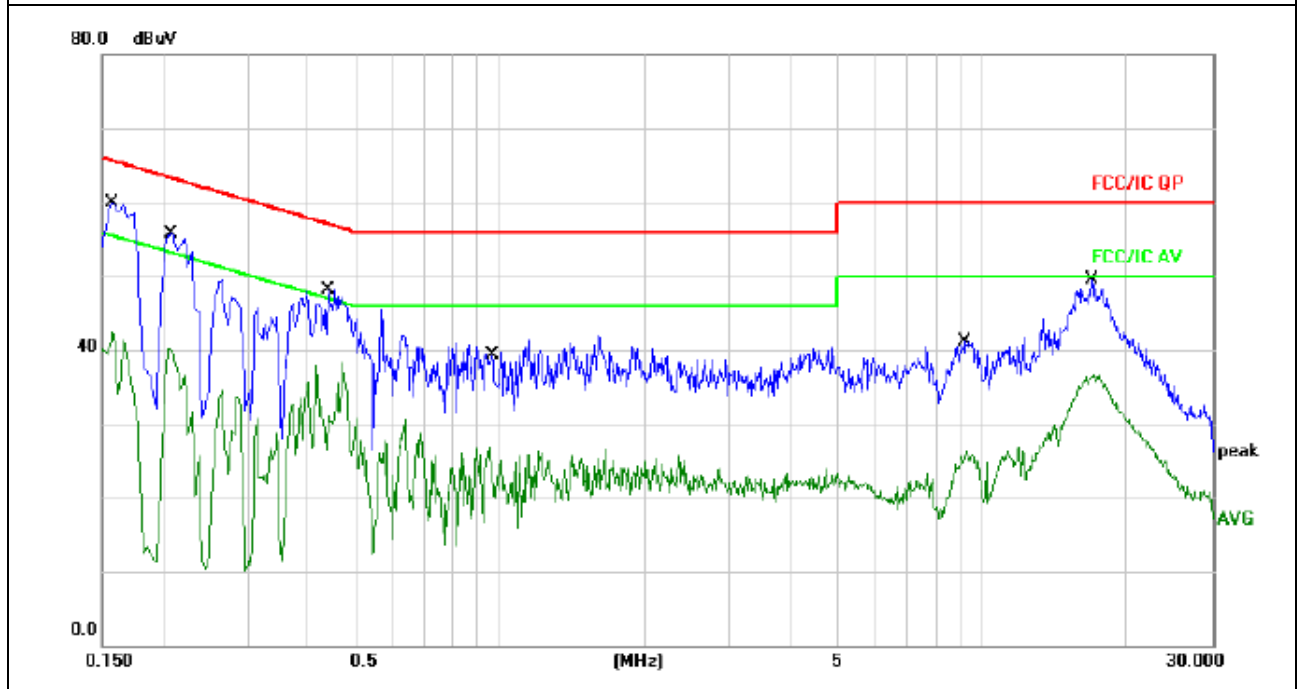





### 3.2 RADIATED EMISSION MEASUREMENT

#### 3.2.1 RADIATED EMISSION LIMITS (Frequency Range 9kHz-1000MHz)

20dBc in any 100 kHz bandwidth outside the operating frequency band. In case the emission fall within the restricted band specified on 15.205(a), then the 15.209(a) limit in the table below has to be followed.

Frequencies (MHz)	Field Strength (microrvolts/meter)	Measurement Distance (meters)
0.009~0.490	2400/F(KHz)	300
0.490~1.705	24000/F(KHz)	30
1.705~30.0	30	30
30~88	100	3
88~216	150	3
216~960	200	3
Above 960	500	3

#### LIMITS OF RADIATED EMISSION MEASUREMENT (Above 1000MHz)

FREQUENCY (MHz)	Class B (dBuV/m) (at 3M)	
	PEAK	AVERAGE
Above 1000	74	54

Notes:

- (1) The limit for radiated test was performed according to FCC PART 15C.
- (2) The tighter limit applies at the band edges.
- (3) Emission level (dBuV/m)=20log Emission level (uV/m).

Spectrum Parameter	Setting
Attenuation	Auto
Start Frequency	1000 MHz
Stop Frequency	10th carrier harmonic
RB / VB (emission in restricted band)	1 MHz / 1 MHz for Peak, 1 MHz / 10Hz for Average

Receiver Parameter	Setting
Attenuation	Auto
Start ~ Stop Frequency	9kHz~150kHz / RB 200Hz for QP
Start ~ Stop Frequency	150kHz~30MHz / RB 9kHz for QP
Start ~ Stop Frequency	30MHz~1000MHz / RB 120kHz for QP



### 3.2.2 TEST PROCEDURE

- a. The measuring distance of at 3 m shall be used for measurements at frequency up to 25GHz. For frequencies above 1GHz, any suitable measuring distance may be used.
- b. The EUT was placed on the top of a rotating table 0.8 and 1.5 meters above the ground at a 3 meter semi-chamber test. The table was rotated 360 degrees to determine the position of the highest radiation.
- c. The height of the equipment or of the substitution antenna shall be 0.8 m; above 1GHz, the height was 1.5m, the height of the test antenna shall vary between 1 m to 4 m. Both horizontal and vertical polarizations of the antenna are set to make the measurement.
- d. The initial step in collecting conducted emission data is a spectrum analyzer peak detector mode pre-scanning the measurement frequency range. Significant peaks are then marked and then Quasi Peak detector mode re-measured.
- e. If the Peak Mode measured value compliance with and lower than Quasi Peak Mode Limit, the EUT shall be deemed to meet QP Limits and then no additional QP Mode measurement performed.
- f. For the actual test configuration, please refer to the related Item –EUT Test Photos.

Note:

Both horizontal and vertical antenna polarities were tested and performed pretest to three orthogonal axis. The worst case emissions were reported

### 3.2.3 DEVIATION FROM TEST STANDARD

No deviation

### 3.2.4 TEST SETUP

#### (A) Radiated Emission Test-Up Frequency Below 30MHz

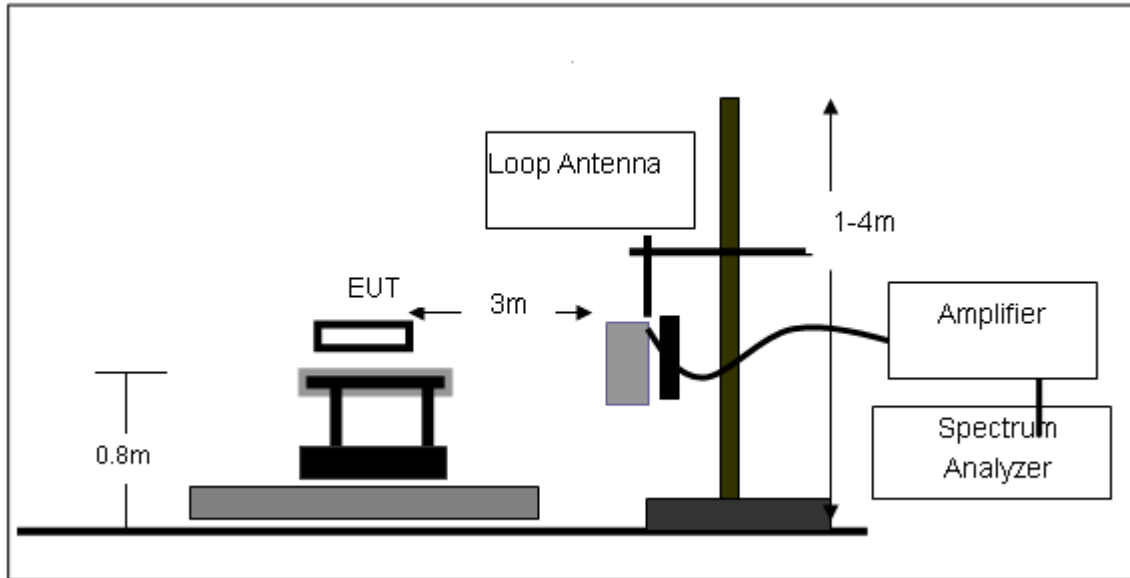

#### (B) Radiated Emission Test-Up Frequency 30MHz~1GHz

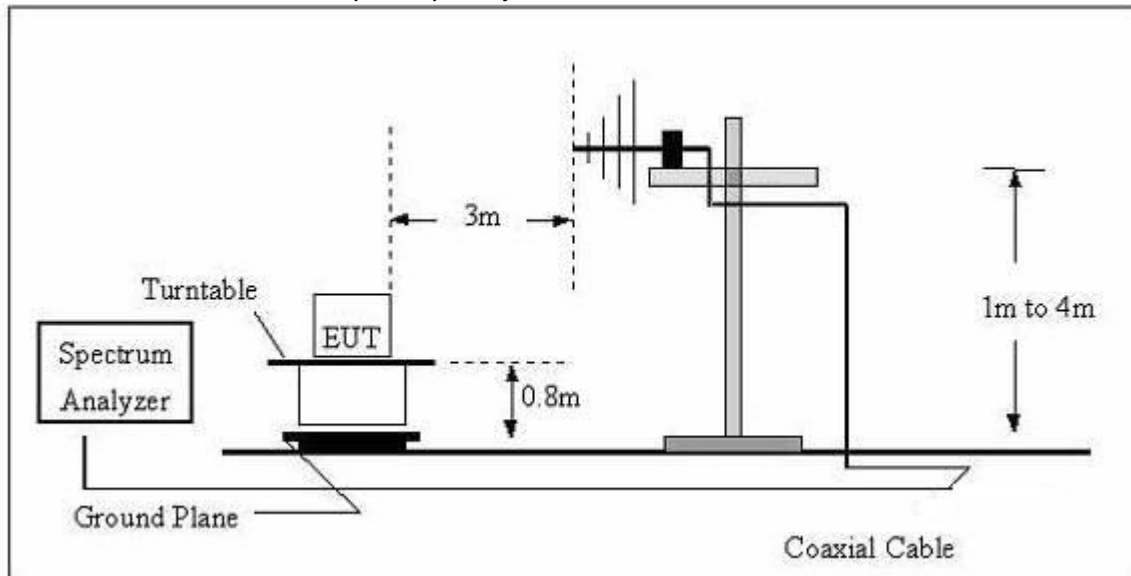

(C) Radiated Emission Test-Up Frequency Above 1GHz

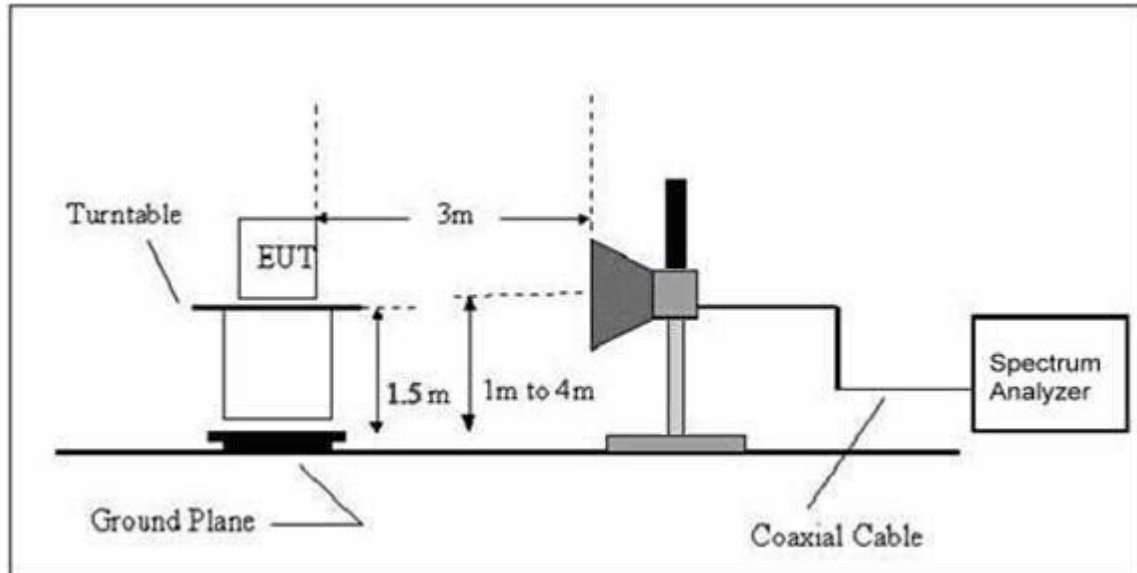

### 3.2.5 EUT OPERATING CONDITIONS

The EUT tested system was configured as the statements of 2.4 Unless otherwise a special operating condition is specified in the follows during the testing.

**3.2.6 TEST RESULTS (BETWEEN 9KHZ – 30 MHZ)**

EUT:	Wireless Router	Model Name. :	Lock 100
Temperature:	25°C	Relative Humidity:	54%
Pressure:	1010 hPa	Test Voltage :	AC120V/60Hz
Test Mode :	TX	Polarization :	--

Freq. (MHz)	Reading (dBuV/m)	Limit (dBuV/m)	Margin (dB)	State P/F
--	--	--	--	PASS
--	--	--	--	PASS

**NOTE:**

The amplitude of spurious emissions which are attenuated by more than 20dB below the permissible value has no need to be reported.

Distance extrapolation factor =  $40 \log(\text{specific distance}/\text{test distance})$ (dB);

Limit line = specific limits(dBuv) + distance extrapolation factor.



### 3.2.7 TEST RESULTS (BETWEEN 30MHZ – 1GHZ)

EUT :	Wireless Router	Model Name :	Lock 100
Temperature :	25°C	Relative Humidity :	55%
Pressure :	1010 hPa	Polarization :	Horizontal
Test Voltage :	DC 12V From Adapter		
Test Mode :	Link Mode		

Frequency (MHz)	Meter Reading (dBμV)	Factor (dB)	Emission Level (dBμV/m)	Limits (dBμV/m)	Margin (dB)	Detector Type
83.8156	45.61	-18.13	27.48	40.00	-12.52	QP
119.8556	48.05	-14.72	33.33	43.50	-10.17	QP
239.9874	49.18	-14.49	34.69	46.00	-11.31	QP
300.3672	46.29	-12.57	33.72	46.00	-12.28	QP
801.7863	42.11	-2.49	39.62	46.00	-6.38	QP
962.1623	42.49	-0.42	42.07	54.00	-11.93	QP

Remark:  
 Factor = Antenna Factor + Cable Loss – Pre-amplifier.  
 All interfaces was connected, and BT TX mode was link.

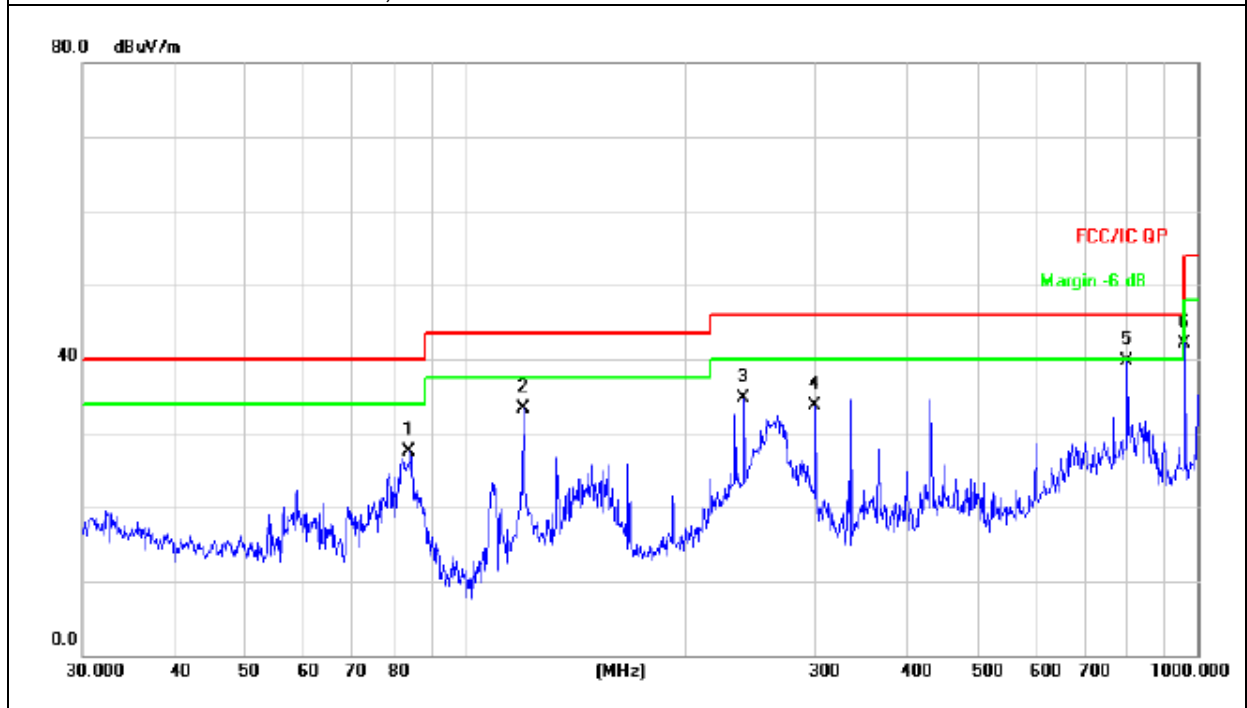



EUT :	Wireless Router	Model Name :	Lock 100
Temperature :	25°C	Relative Humidity :	55%
Pressure :	1010 hPa	Polarization :	Vertical
Test Voltage :	DC 12V From Adapter		
Test Mode :	Link Mode		

Frequency (MHz)	Meter Reading (dBµV)	Factor (dB)	Emission Level (dBµV/m)	Limits (dBµV/m)	Margin (dB)	Detector Type
33.0950	45.64	-8.39	37.25	40.00	-2.75	QP
42.8998	44.31	-9.21	35.10	40.00	-4.90	QP
82.9385	54.08	-18.12	35.96	40.00	-4.04	QP
119.8556	50.80	-14.72	36.08	43.50	-7.42	QP
336.0352	47.52	-11.66	35.86	46.00	-10.14	QP
601.4265	43.66	-5.66	38.00	46.00	-8.00	QP

Remark:  
 Factor = Antenna Factor + Cable Loss – Pre-amplifier.  
 All interfaces was connected, and BT TX mode was link.

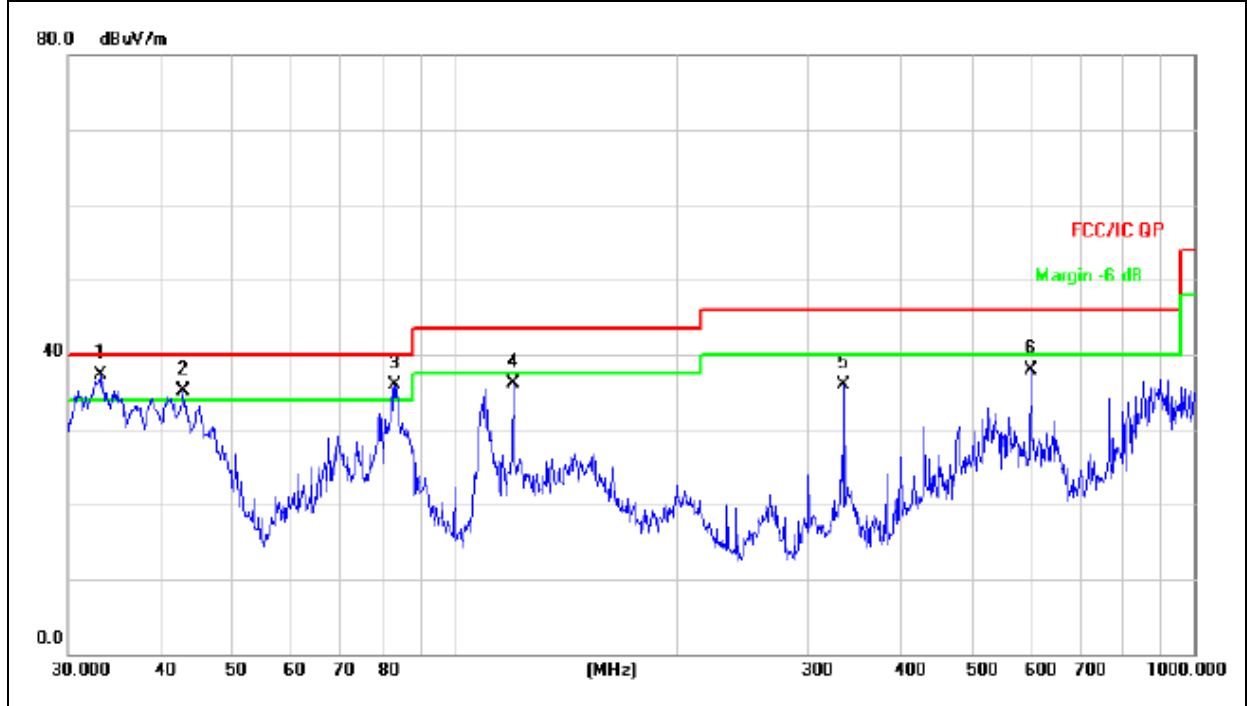



**3.2.8 TEST RESULTS (ABOVE 1000 MHZ)**

**802.11b**

Normal Voltage

Polar (H/V)	Frequency	Meter Reading	Factor	Emission Level	Limits	Margin	Detector Type
	(MHz)	(dBuV)	(dB)	(dBuV/m)	(dBuV/m)	(dB)	
<b>operation frequency:2412</b>							
V	4824.00	45.65	19.36	65.01	74	-8.99	Pk
V	4824.00	26.58	19.36	45.94	54	-8.06	AV
V	7236.00	46.23	17.17	63.4	74	-10.60	Pk
V	7236.00	27.35	17.17	44.52	54	-9.48	AV
H	4824.00	46.23	19.36	65.59	74	-8.41	Pk
H	4824.00	26.87	19.36	46.23	54	-7.77	AV
H	7236.00	47.73	17.17	64.9	74	-9.10	Pk
H	7236.00	27.44	17.17	44.61	54	-9.39	AV
<b>Remark:</b>							
Absolute Level= ReadingLevel+ Factor							
Margin= Limit- Absolute Level							
The radiated emissions from 8GHz to 25GHz are at least 20dB below the official limit and no need to report.							

**802.11b**

Normal Voltage

Polar (H/V)	Frequency	Meter Reading	Factor	Emission Level	Limits	Margin	Detector Type
	(MHz)	(dBuV)	(dB)	(dBuV/m)	(dBuV/m)	(dB)	
<b>operation frequency:2437</b>							
V	4874.00	46.36	19.42	65.78	74	-8.22	Pk
V	4874.00	27.78	19.42	47.2	54	-6.8	AV
V	7311.00	47.65	17.19	64.84	74	-9.16	Pk
V	7311.00	27.82	17.19	45.01	54	-8.99	AV
H	4874.00	46.53	19.42	65.95	74	-8.05	Pk
H	4874.00	26.47	19.42	45.89	54	-8.11	AV
H	7311.00	47.62	17.19	64.81	74	-9.19	Pk
H	7311.00	27.65	17.19	44.84	54	-9.16	AV
<b>Remark:</b>							
Absolute Level= ReadingLevel+ Factor							
Margin= Limit- Absolute Level							
The radiated emissions from 8GHz to 25GHz are at least 20dB below the official limit and no need to report.							





**802.11b**

Normal Voltage

Polar (H/V)	Frequency	Meter Reading	Factor	Emission Level	Limits	Margin	Detector Type
	(MHz)	(dBuV)	(dB)	(dBuV/m)	(dBuV/m)	(dB)	
<b>operation frequency:2462</b>							
V	4924.00	47.37	19.47	66.84	74	-7.16	Pk
V	4924.00	26.51	19.47	45.98	54	-8.02	AV
V	7386.00	47.64	17.22	64.86	74	-9.14	Pk
V	7376.00	26.27	17.22	43.49	54	-10.51	AV
H	4924.00	45.86	19.47	65.33	74	-8.67	Pk
H	4924.00	26.65	19.47	46.12	54	-7.88	AV
H	7386.00	46.85	17.22	64.07	74	-9.93	Pk
H	7376.00	27.15	17.22	44.37	54	-9.63	AV
<b>Remark:</b>							
Absolute Level= ReadingLevel+ Factor							
Margin= Limit- Absolute Level							
The radiated emissions from 8GHz to 25GHz are at least 20dB below the official limit and no need to report.							



**802.11g**

Normal Voltage

Polar (H/V)	Frequency	Meter Reading	Factor	Emission Level	Limits	Margin	Detector Type
	(MHz)	(dBuV)	(dB)	(dBuV/m)	(dBuV/m)	(dB)	
<b>operation frequency:2412</b>							
V	4824.00	45.65	19.36	65.01	74	-8.99	Pk
V	4824.00	26.51	19.36	45.87	54	-8.13	AV
V	7236.00	46.43	17.17	63.6	74	-10.40	Pk
V	7236.00	27.35	17.17	44.52	54	-9.48	AV
H	4824.00	46.23	19.36	65.59	74	-8.41	Pk
H	4824.00	26.85	19.36	46.21	54	-7.79	AV
H	7236.00	47.53	17.17	64.7	74	-9.30	Pk
H	7236.00	27.46	17.17	44.63	54	-9.37	AV
<b>Remark:</b>							
Absolute Level= ReadingLevel+ Factor							
Margin= Limit- Absolute Level							
The radiated emissions from 8GHz to 25GHz are at least 20dB below the official limit and no need to report.							

**802.11g**

Normal Voltage

Polar (H/V)	Frequency	Meter Reading	Factor	Emission Level	Limits	Margin	Detector Type
	(MHz)	(dBuV)	(dB)	(dBuV/m)	(dBuV/m)	(dB)	
<b>operation frequency:2437</b>							
V	4874.00	45.36	19.42	64.78	74	-9.22	Pk
V	4874.00	26.78	19.42	46.2	54	-7.80	AV
V	7311.00	46.65	17.19	63.84	74	-10.16	Pk
V	7311.00	27.85	17.19	45.04	54	-8.96	AV
H	4874.00	46.55	19.42	65.97	74	-8.03	Pk
H	4874.00	26.46	19.42	45.88	54	-8.12	AV
H	7311.00	47.45	17.19	64.64	74	-9.36	Pk
H	7311.00	27.62	17.19	44.81	54	-9.19	AV
<b>Remark:</b>							
Absolute Level= ReadingLevel+ Factor							
Margin= Limit- Absolute Level							
The radiated emissions from 8GHz to 25GHz are at least 20dB below the official limit and no need to report.							



**802.11g**

Normal Voltage

Polar (H/V)	Frequency	Meter Reading	Factor	Emission Level	Limits	Margin	Detector Type
	(MHz)	(dBuV)	(dB)	(dBuV/m)	(dBuV/m)	(dB)	
<b>operation frequency:2462</b>							
V	4924.00	46.37	19.47	65.84	74	-8.16	Pk
V	4924.00	26.57	19.47	46.04	54	-7.96	AV
V	7386.00	47.63	17.22	64.85	74	-9.15	Pk
V	7386.00	26.25	17.22	43.47	54	-10.53	AV
H	4924.00	45.81	19.47	65.28	74	-8.72	Pk
H	4924.00	26.62	19.47	46.09	54	-7.91	AV
H	7386.00	46.83	17.22	64.05	74	-9.95	Pk
H	7386.00	27.35	17.22	44.57	54	-9.43	AV
<b>Remark:</b>							
Absolute Level= ReadingLevel+ Factor							
Margin= Limit- Absolute Level							
The radiated emissions from 8GHz to 25GHz are at least 20dB below the official limit and no need to report.							



**802.11 n(20)**

Normal Voltage

Polar (H/V)	Frequency	Meter Reading	Factor	Emission Level	Limits	Margin	Detector Type
	(MHz)	(dBuV)	(dB)	(dBuV/m)	(dBuV/m)	(dB)	
<b>operation frequency:2412</b>							
V	4824.00	47.62	19.36	66.98	74	-7.02	Pk
V	4824.00	26.23	19.36	45.59	54	-8.41	AV
V	7236.00	47.12	17.17	64.29	74	-9.71	Pk
V	7236.00	27.35	17.17	44.52	54	-9.48	AV
H	4824.00	46.65	19.36	66.01	74	-7.99	Pk
H	4824.00	26.87	19.36	46.23	54	-7.77	AV
H	7236.00	47.74	17.17	64.91	74	-9.09	Pk
H	7236.00	27.43	17.17	44.6	54	-9.40	AV
<b>Remark:</b>							
Absolute Level= ReadingLevel+ Factor							
Margin= Limit- Absolute Level							
The radiated emissions from 8GHz to 25GHz are at least 20dB below the official limit and no need to report.							

**802.11n(20)**

Normal Voltage

Polar (H/V)	Frequency	Meter Reading	Factor	Emission Level	Limits	Margin	Detector Type
	(MHz)	(dBuV)	(dB)	(dBuV/m)	(dBuV/m)	(dB)	
<b>operation frequency:2437</b>							
V	4874.00	46.56	19.42	65.98	74	-8.02	Pk
V	4874.00	27.83	19.42	47.25	54	-6.75	AV
V	7311.00	47.69	17.19	64.88	74	-9.12	Pk
V	7311.00	27.55	17.19	44.74	54	-9.26	AV
H	4874.00	46.32	19.42	65.74	74	-8.26	Pk
H	4874.00	26.35	19.42	45.77	54	-8.23	AV
H	7311.00	47.86	17.19	65.05	74	-8.95	Pk
H	7311.00	27.18	17.19	44.37	54	-9.63	AV
<b>Remark:</b>							
Absolute Level= ReadingLevel+ Factor							
Margin= Limit- Absolute Level							
The radiated emissions from 8GHz to 25GHz are at least 20dB below the official limit and no need to report.							



**802.11 n(20)**

Normal Voltage

Polar (H/V)	Frequency	Meter Reading	Factor	Emission Level	Limits	Margin	Detector Type
	(MHz)	(dBuV)	(dB)	(dBuV/m)	(dBuV/m)	(dB)	
<b>operation frequency:2462</b>							
V	4924.00	45.85	19.47	65.32	74	-8.68	Pk
V	4924.00	25.56	19.47	45.03	54	-8.97	AV
V	7386.00	47.47	17.22	64.69	74	-9.31	Pk
V	7376.00	26.65	17.22	43.87	54	-10.13	AV
H	4924.00	45.79	19.47	65.26	74	-8.74	Pk
H	4924.00	26.23	19.47	45.7	54	-8.30	AV
H	7386.00	46.45	17.22	63.67	74	-10.33	Pk
H	7376.00	26.67	17.22	43.89	54	-10.11	AV
<b>Remark:</b>							
Absolute Level= ReadingLevel+ Factor							
Margin= Limit- Absolute Level							
The radiated emissions from 8GHz to 25GHz are at least 20dB below the official limit and no need to report.							

**802.11n(40MHz)**

Normal Voltage

Polar (H/V)	Frequency	Meter Reading	Factor	Emission Level	Limits	Margin	Detector Type
	(MHz)	(dBuV)	(dB)	(dBuV/m)	(dBuV/m)	(dB)	
<b>operation frequency:2422</b>							
V	4844.00	46.56	19.38	65.94	74	-8.06	Pk
V	4844.00	25.83	19.38	45.21	54	-8.79	AV
V	7266.00	47.64	17.18	64.82	74	-9.18	Pk
V	7266.00	26.55	17.18	43.73	54	-10.27	AV
H	4844.00	46.22	19.38	65.6	74	-8.40	Pk
H	4844.00	26.37	19.38	45.75	54	-8.25	AV
H	7266.00	47.52	17.18	64.7	74	-9.30	Pk
H	7266.00	27.05	17.18	44.23	54	-9.77	AV
<b>Remark:</b>							
Absolute Level= ReadingLevel+ Factor							
Margin= Limit- Absolute Level							
The radiated emissions from 8GHz to 25GHz are at least 20dB below the official limit and no need to report.							

**802.11n(40MHz)**

Normal Voltage

Polar (H/V)	Frequency	Meter Reading	Factor	Emission Level	Limits	Margin	Detector Type
	(MHz)	(dBuV)	(dB)	(dBuV/m)	(dBuV/m)	(dB)	
<b>operation frequency:2437</b>							
V	4874.00	46.35	19.42	65.77	74	-8.23	Pk
V	4874.00	26.64	19.42	46.06	54	-7.94	AV
V	7311.00	47.33	17.19	64.52	74	-9.48	Pk
V	7311.00	27.12	17.19	44.31	54	-9.69	AV
H	4874.00	46.37	19.42	65.79	74	-8.21	Pk
H	4874.00	26.44	19.42	45.86	54	-8.14	AV
H	7311.00	47.61	17.19	64.8	74	-9.20	Pk
H	7311.00	27.02	17.19	44.21	54	-9.79	AV
<b>Remark:</b>							
Absolute Level= ReadingLevel+ Factor							
Margin= Limit- Absolute Level							
The radiated emissions from 8GHz to 25GHz are at least 20dB below the official limit and no need to report.							



**802.11n(40MHz)**

Normal Voltage

Polar (H/V)	Frequency	Meter Reading	Factor	Emission Level	Limits	Margin	Detector Type
	(MHz)	(dBuV)	(dB)	(dBuV/m)	(dBuV/m)	(dB)	
<b>operation frequency:2452</b>							
V	4904.00	46.65	19.45	66.1	74	-7.90	Pk
V	4904.00	26.37	19.45	45.82	54	-8.18	AV
V	7356.00	47.39	17.21	64.6	74	-9.40	Pk
V	7356.00	27.22	7.21	34.43	54	-19.57	AV
H	4904.00	46.63	19.45	66.08	74	-7.92	Pk
H	4904.00	26.49	19.45	45.94	54	-8.06	AV
H	7356.00	47.62	17.21	64.83	74	-9.17	Pk
H	7356.00	27.34	17.21	44.55	54	-9.45	AV
<b>Remark:</b>							
Absolute Level= ReadingLevel+ Factor							
Margin= Limit- Absolute Level							
The radiated emissions from 8GHz to 25GHz are at least 20dB below the official limit and no need to report.							

Note: the data of ANT1 only show the worst result.



Conducted Test

802.11b

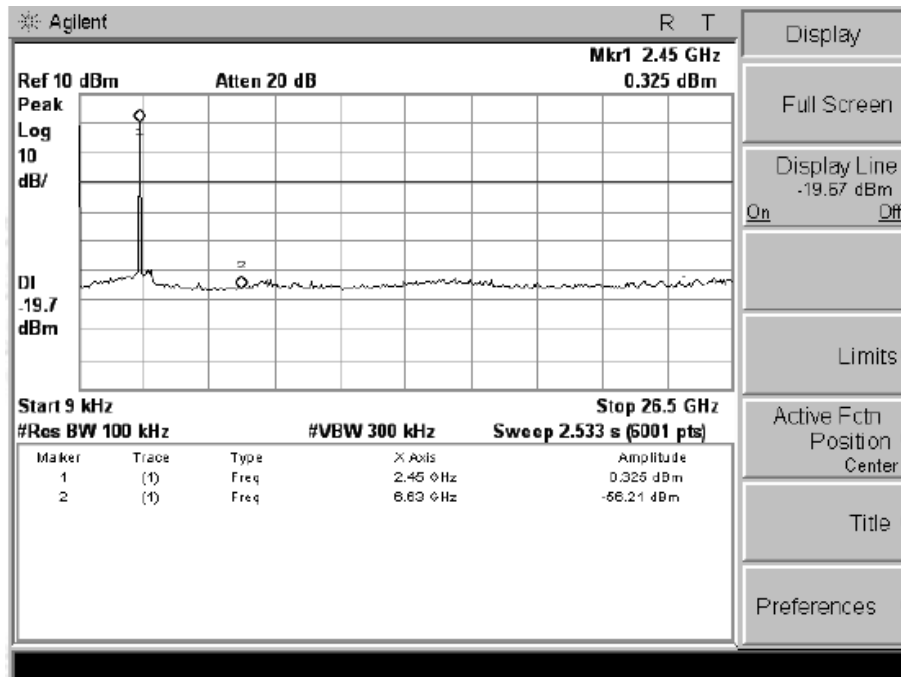
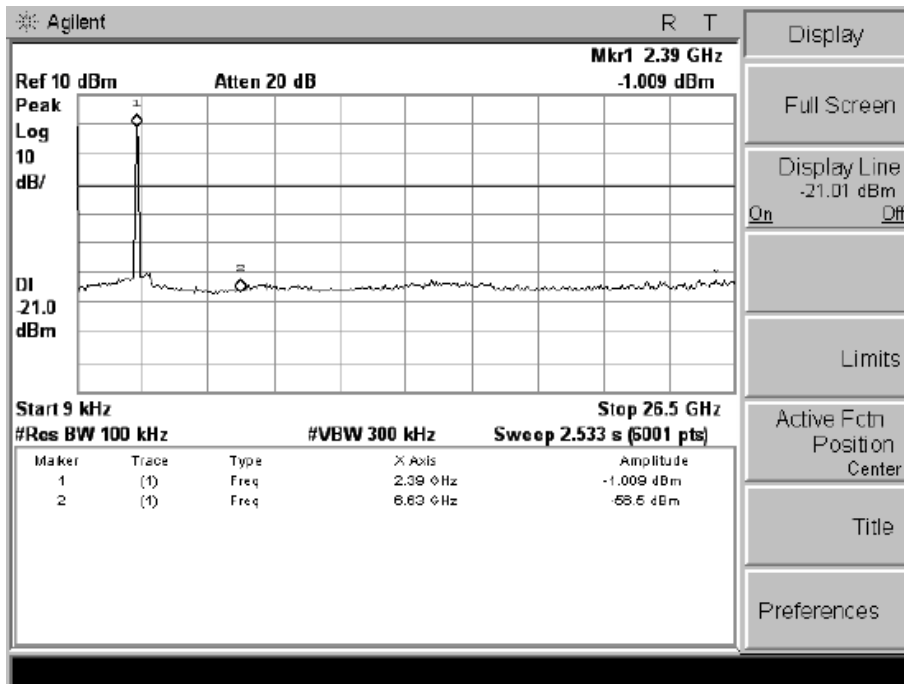



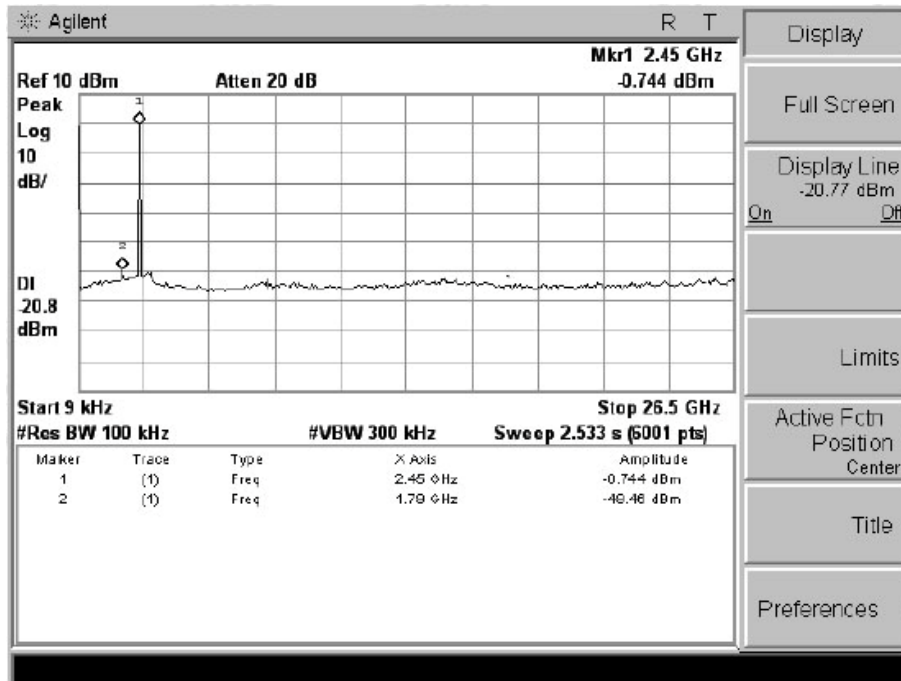

### 802.11g

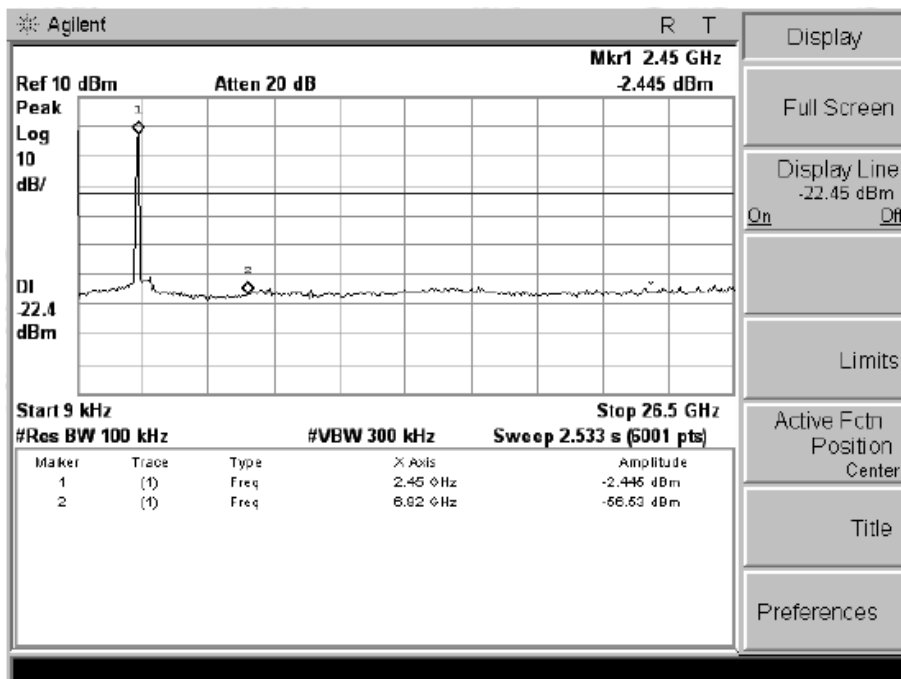

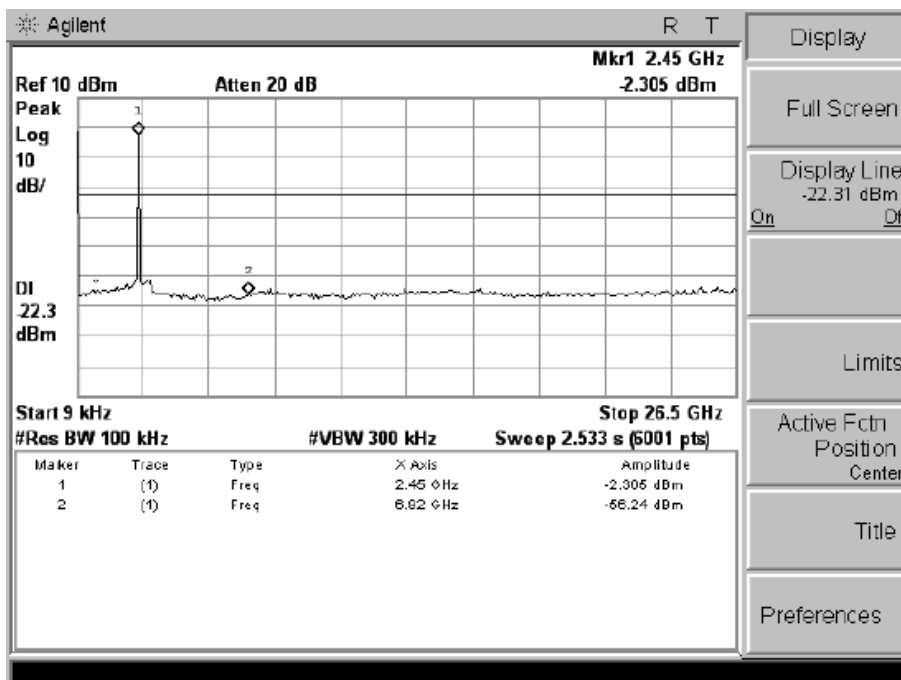
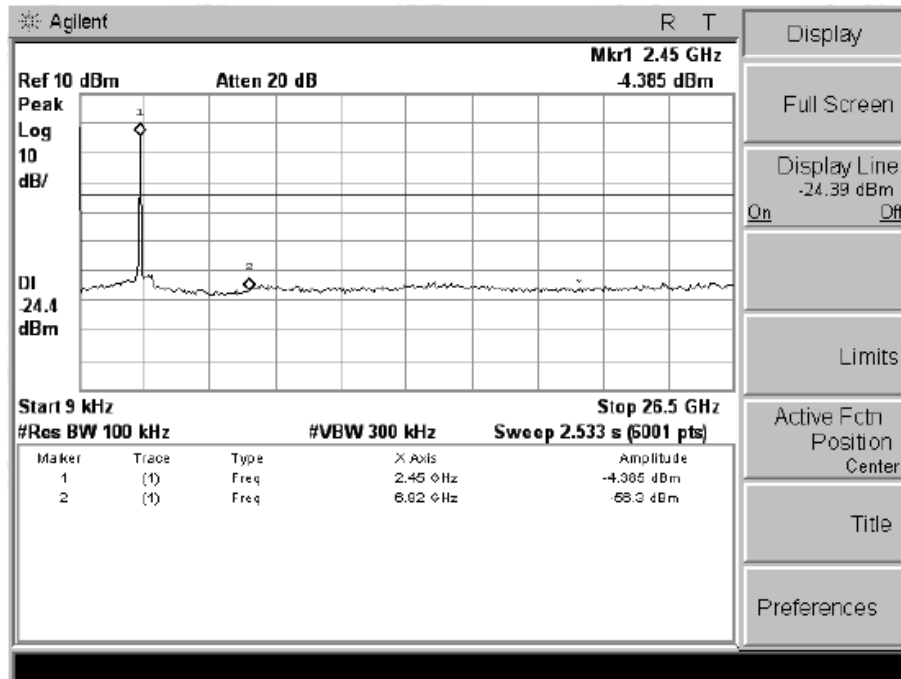



802.11n(20)

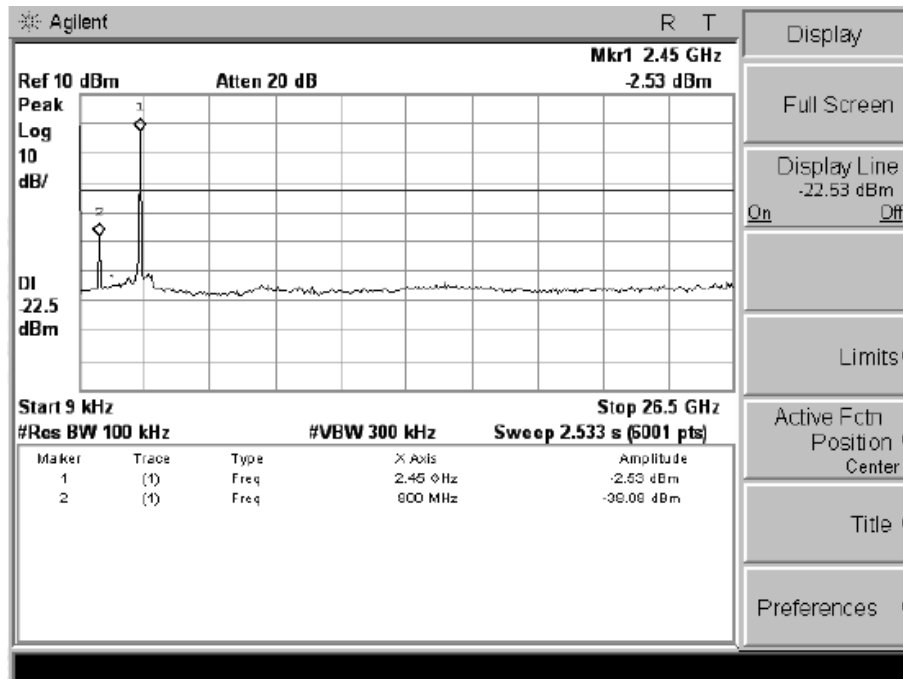
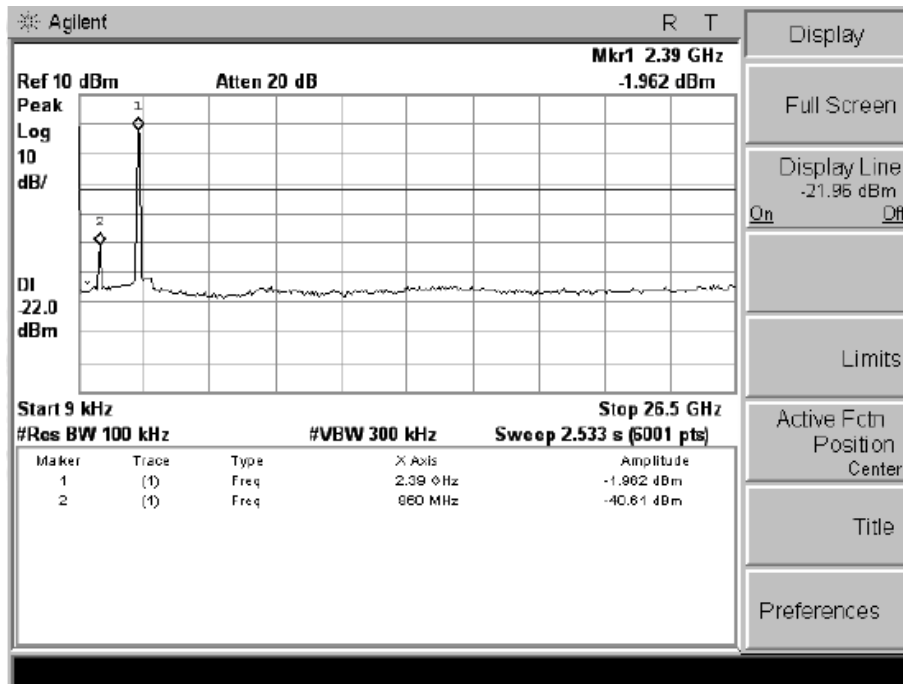

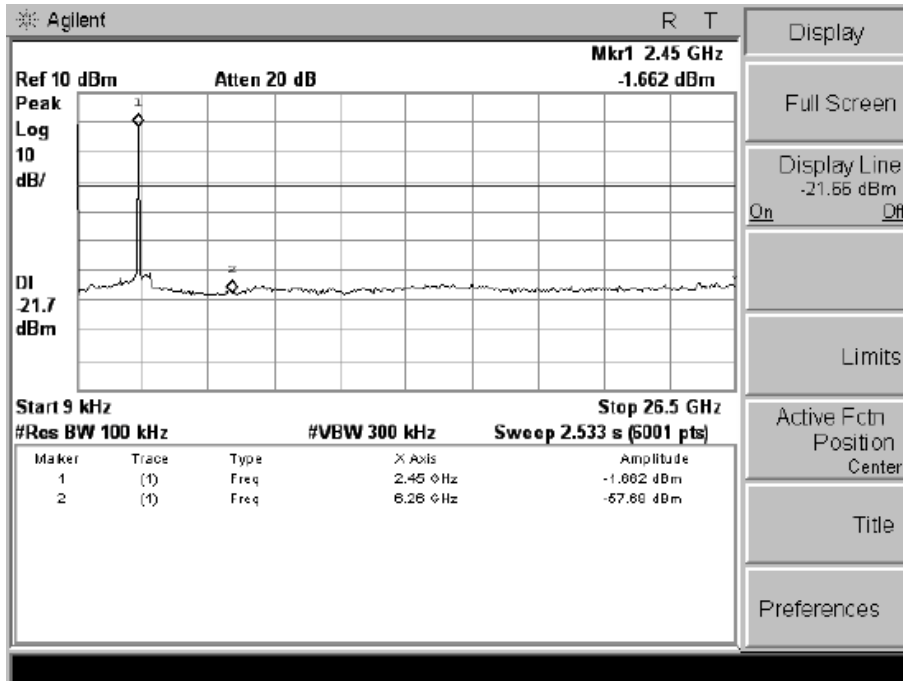

802.11n(40)

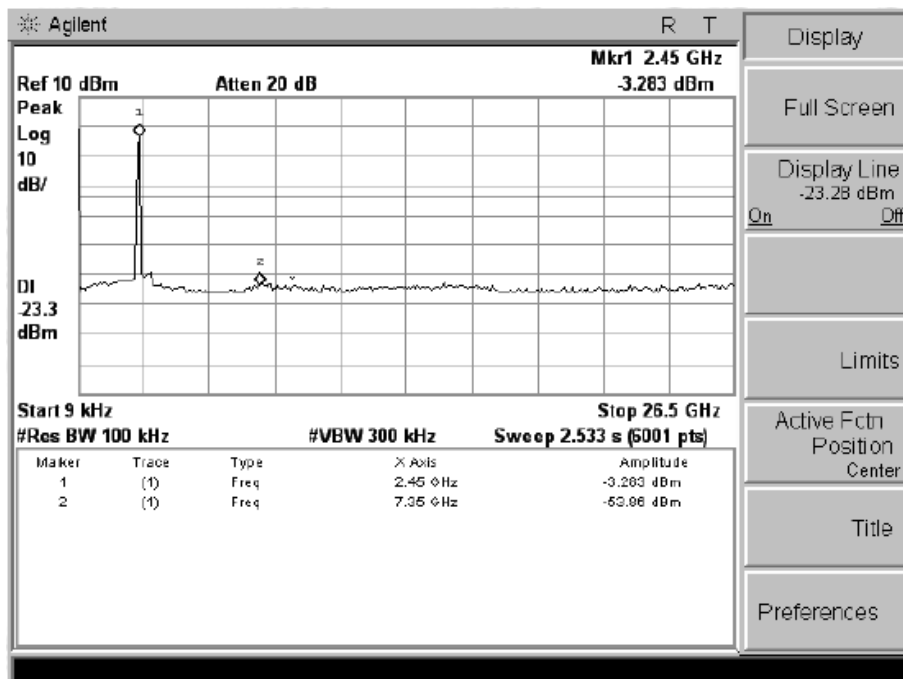

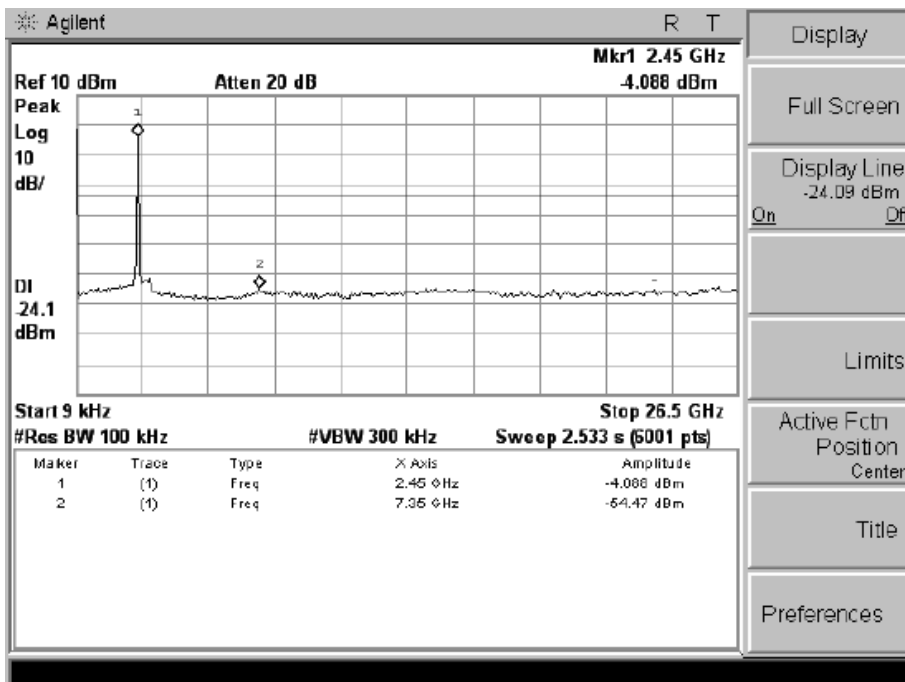
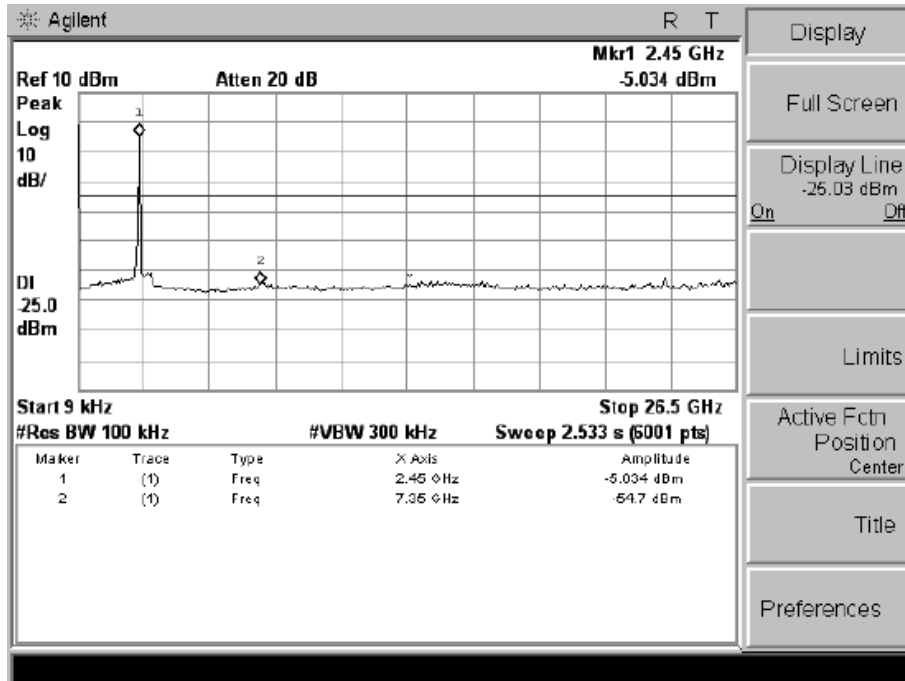

Note: the data of ANT1 only show the worst result.



Band Radiated

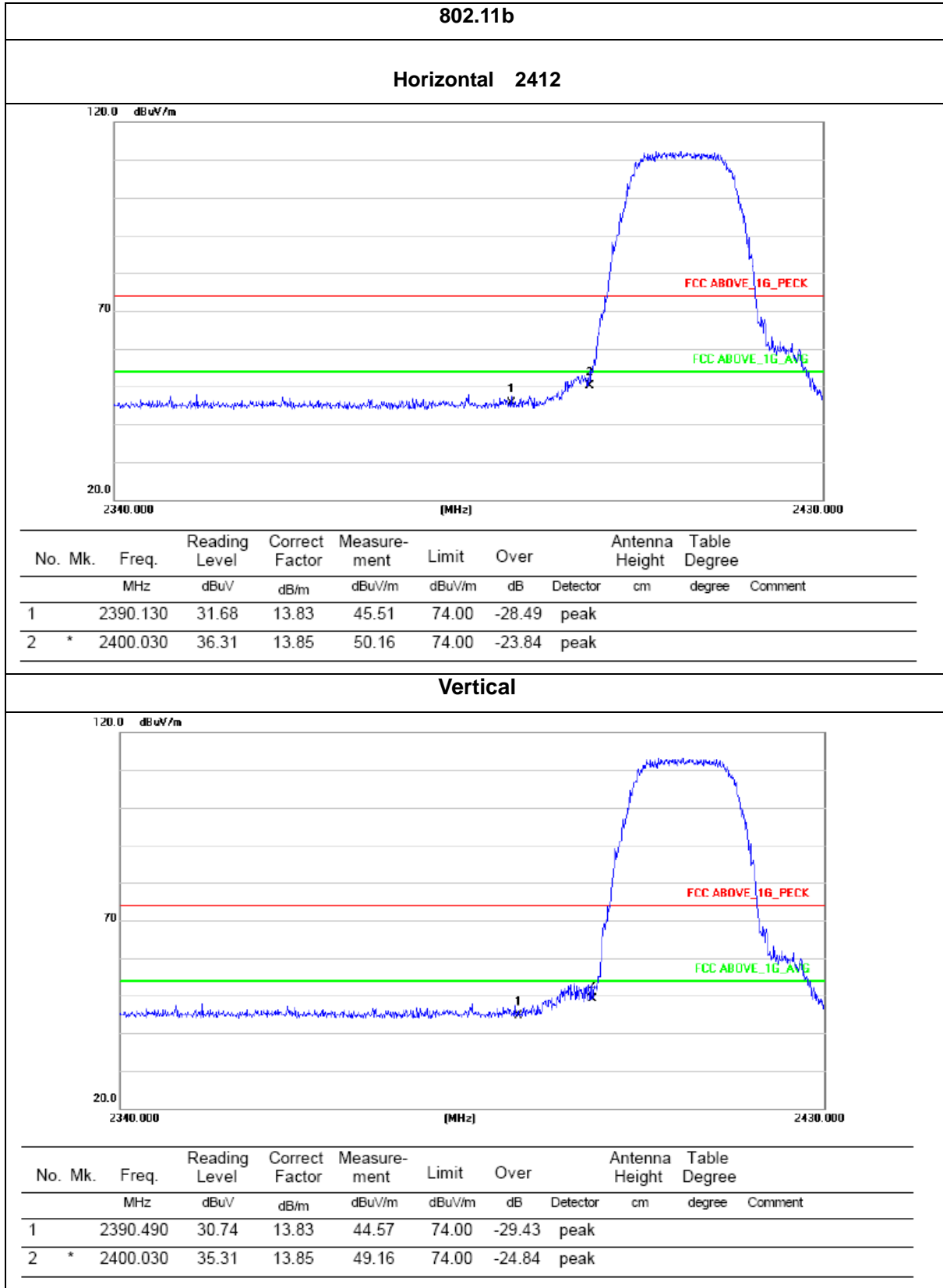



**Horizontal 2462**

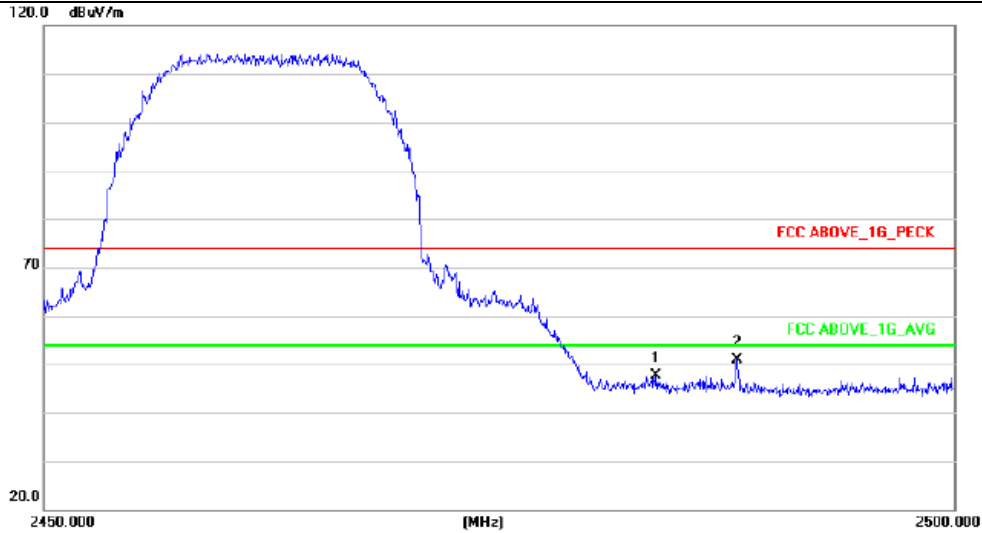

No.	Mk.	Freq.	Reading Level	Correct Factor	Measurement	Limit	Over	Antenna Height	Table Degree
		MHz	dBuV	dB/m	dBuV/m	dBuV/m	dB	cm	degree
1		2483.550	33.71	14.02	47.73	74.00	-26.27	peak	
2	*	2488.050	36.76	14.04	50.80	74.00	-23.20	peak	

**Vertical**

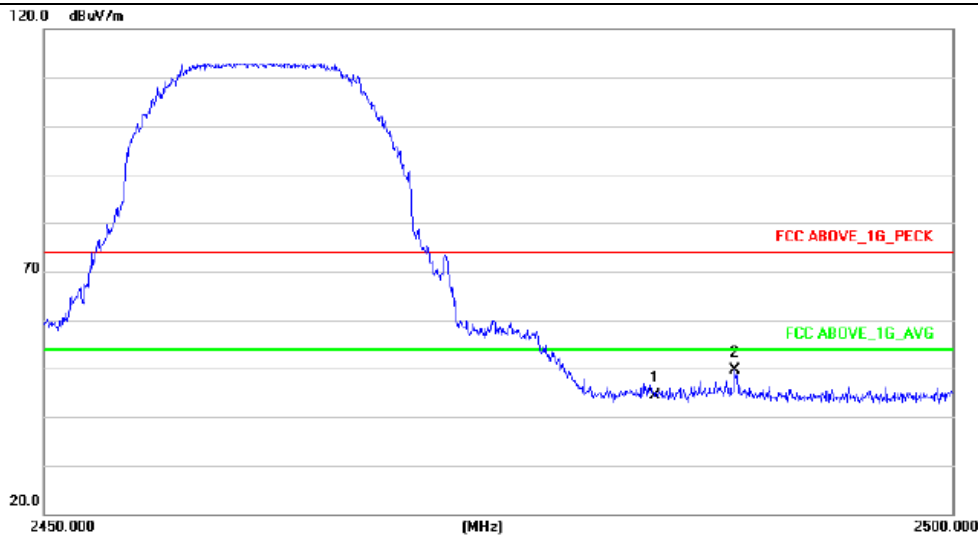

No.	Mk.	Freq.	Reading Level	Correct Factor	Measurement	Limit	Over	Antenna Height	Table Degree
		MHz	dBuV	dB/m	dBuV/m	dBuV/m	dB	cm	degree
1		2483.550	30.35	14.02	44.37	74.00	-29.63	peak	
2	*	2488.000	35.49	14.04	49.53	74.00	-24.47	peak	



802.11g

Horizontal 2412

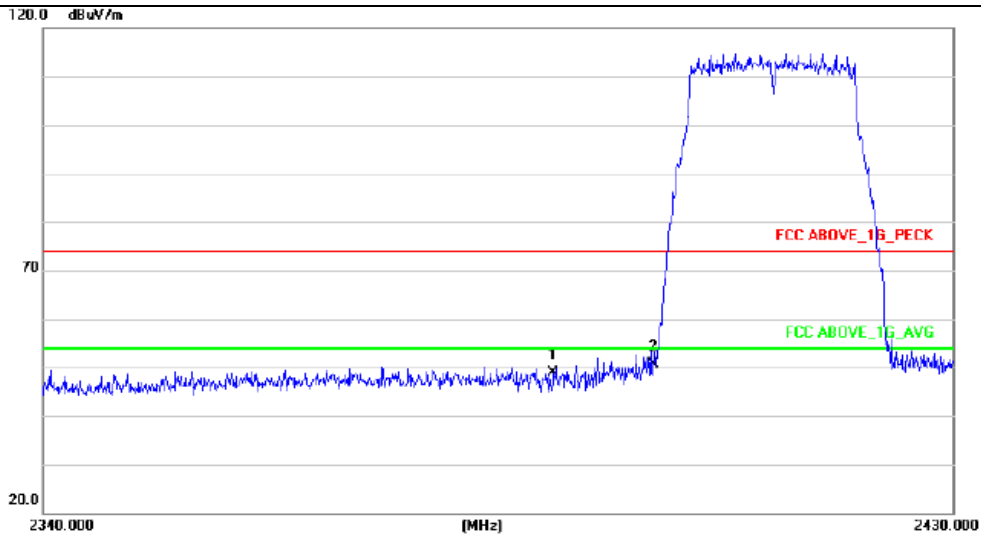

No.	Mk.	Freq.	Reading Level	Correct Factor	Measurement	Limit	Over	Antenna Height	Table Degree	
		MHz	dBuV	dB/m	dBuV/m	dBuV/m	dB	cm	degree	Comment
1		2390.130	35.11	13.83	48.94	74.00	-25.06			peak
2	*	2400.030	36.69	13.85	50.54	74.00	-23.46			peak

Vertical

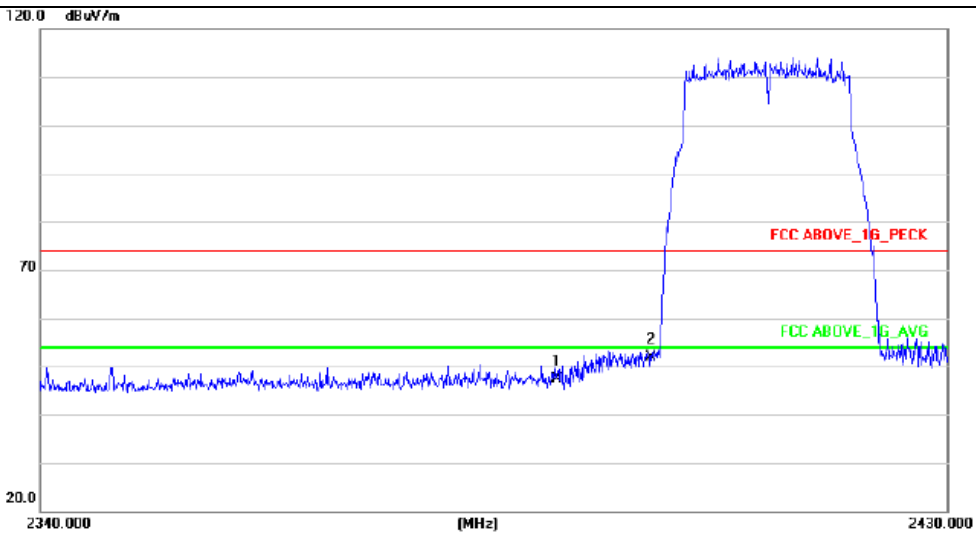

No.	Mk.	Freq.	Reading Level	Correct Factor	Measurement	Limit	Over	Antenna Height	Table Degree	
		MHz	dBuV	dB/m	dBuV/m	dBuV/m	dB	cm	degree	Comment
1		2390.850	33.64	13.83	47.47	74.00	-26.53			peak
2	*	2400.300	37.93	13.85	51.78	74.00	-22.22			peak





**Horizontal 2462**

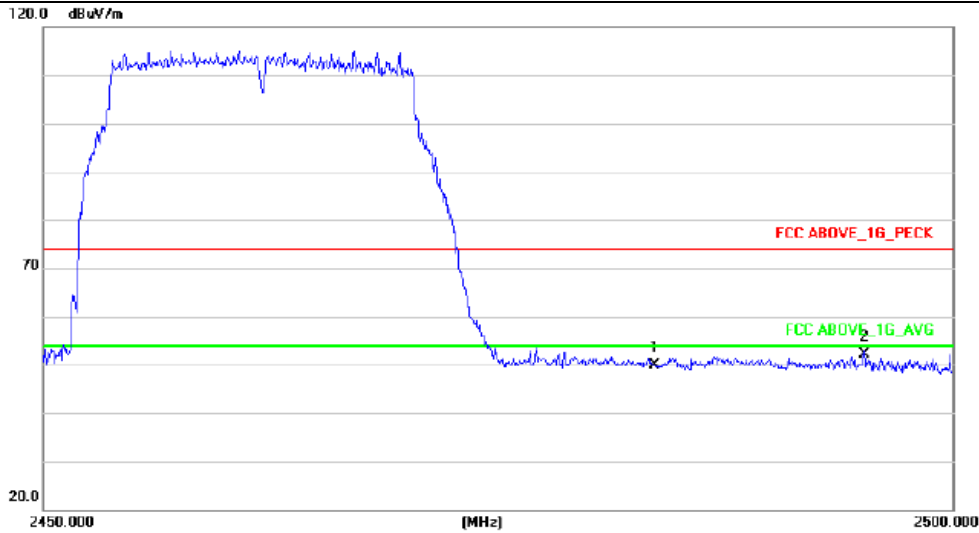

No.	Mk.	Freq.	Reading Level	Correct Factor	Measurement	Limit	Over	Antenna Height	Table Degree	
		MHz	dBuV	dB/m	dBuV/m	dBuV/m	dB	cm	degree	Comment
1		2483.550	35.76	14.02	49.78	74.00	-24.22			peak
2	*	2495.100	38.07	14.04	52.11	74.00	-21.89			peak

**Vertical**

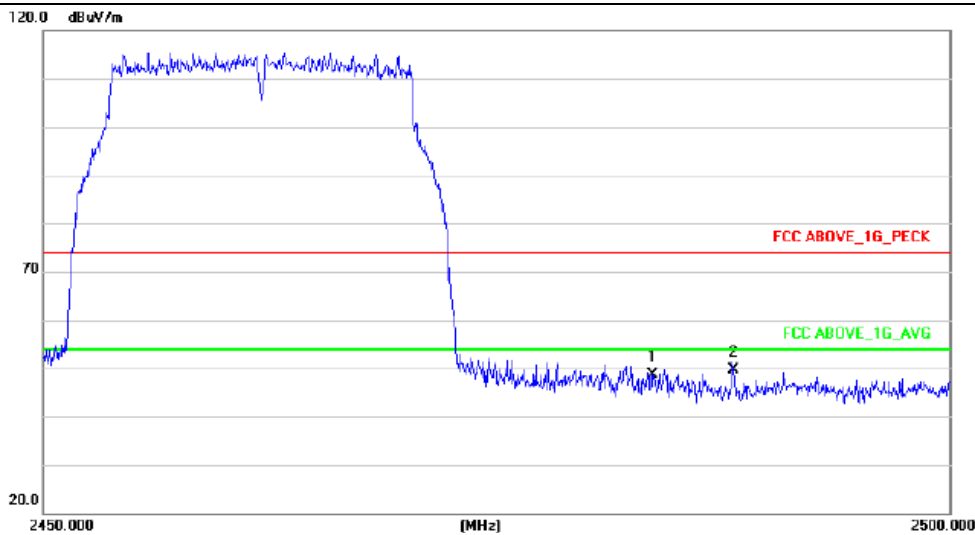

No.	Mk.	Freq.	Reading Level	Correct Factor	Measurement	Limit	Over	Antenna Height	Table Degree	
		MHz	dBuV	dB/m	dBuV/m	dBuV/m	dB	cm	degree	Comment
1		2483.500	34.50	14.02	48.52	74.00	-25.48			peak
2	*	2488.050	35.69	14.04	49.73	74.00	-24.27			peak



802.11n(20)

Horizontal 2412

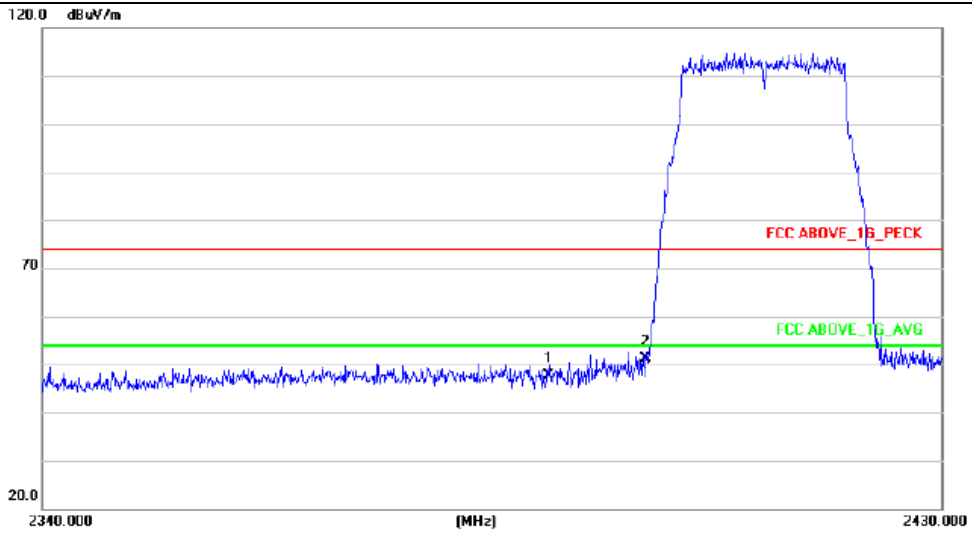

No.	Mk.	Freq.	Reading Level	Correct Factor	Measurement	Limit	Over	Antenna Height	Table Degree	
		MHz	dBuV	dB/m	dBuV/m	dBuV/m	dB	cm	degree	Comment
1		2390.220	33.89	13.83	47.72	74.00	-26.28			peak
2	*	2400.030	37.19	13.85	51.04	74.00	-22.96			peak

Vertical

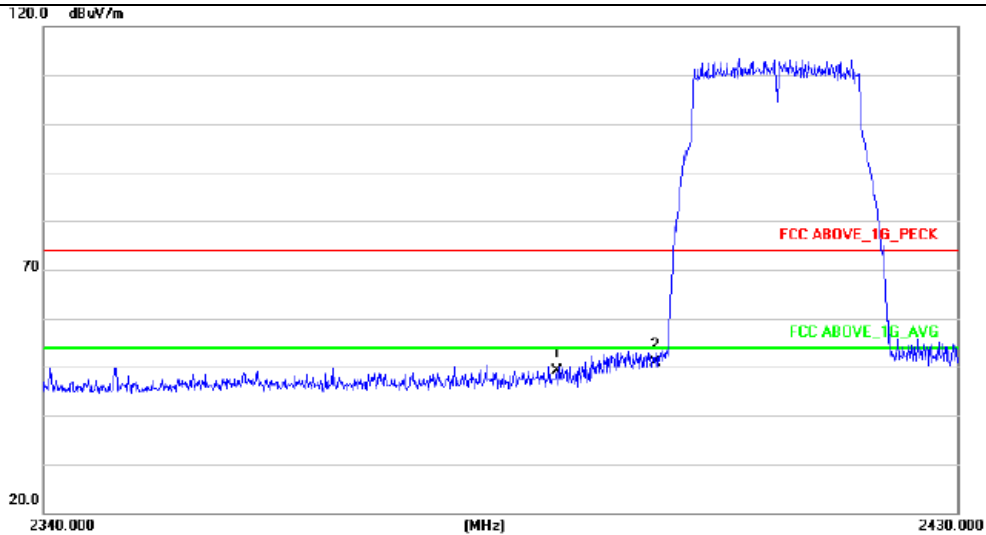

No.	Mk.	Freq.	Reading Level	Correct Factor	Measurement	Limit	Over	Antenna Height	Table Degree	
		MHz	dBuV	dB/m	dBuV/m	dBuV/m	dB	cm	degree	Comment
1		2390.220	35.18	13.83	49.01	74.00	-24.99			peak
2	*	2400.000	37.12	13.85	50.97	74.00	-23.03			peak



**Horizontal 2462**

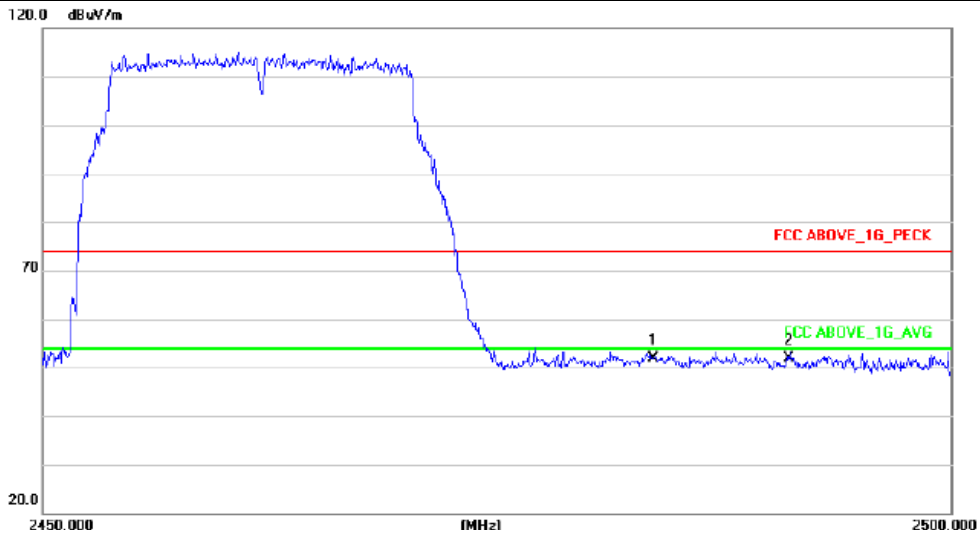

No.	Mk.	Freq.	Reading Level	Correct Factor	Measurement	Limit	Over	Antenna Height	Table Degree	
		MHz	dBuV	dB/m	dBuV/m	dBuV/m	dB	cm	degree	Comment
1		2483.550	37.76	14.02	51.78	74.00	-22.22	peak		
2	*	2491.050	37.90	14.04	51.94	74.00	-22.06	peak		

**Vertical**

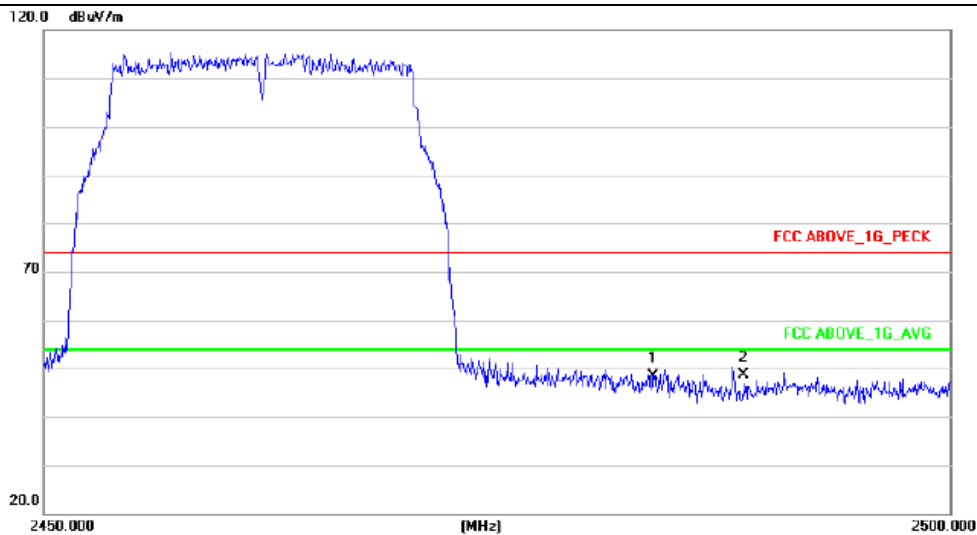

No.	Mk.	Freq.	Reading Level	Correct Factor	Measurement	Limit	Over	Antenna Height	Table Degree	
		MHz	dBuV	dB/m	dBuV/m	dBuV/m	dB	cm	degree	Comment
1		2483.550	34.48	14.02	48.50	74.00	-25.50	peak		
2	*	2488.550	34.69	14.04	48.73	74.00	-25.27	peak		



802.11n(40)

Horizontal 2422

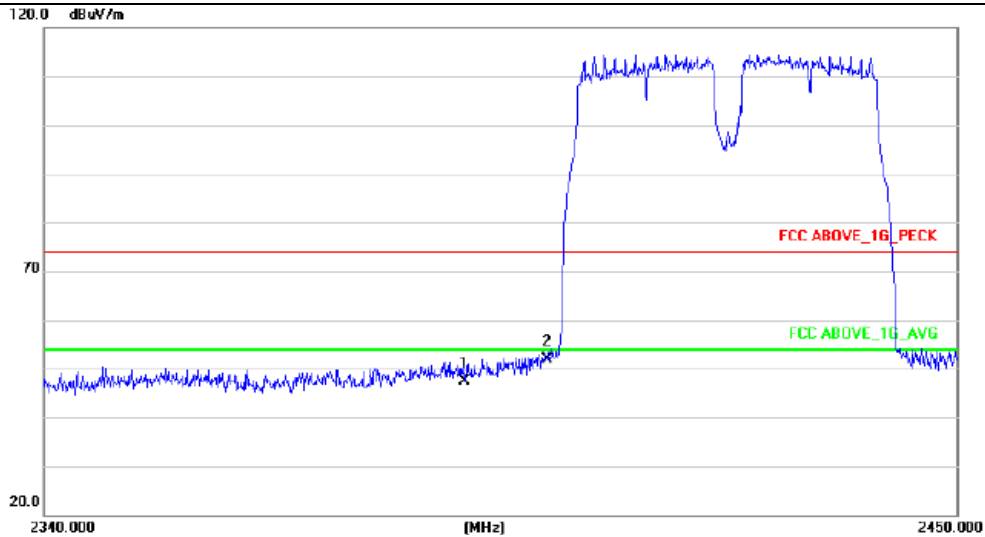

No.	Mk.	Freq.	Reading Level	Correct Factor	Measurement	Limit	Over	Antenna Height	Table Degree
		MHz	dBuV	dB/m	dBuV/m	dBuV/m	dB	cm	degree
1		2390.000	33.52	13.83	47.35	74.00	-26.65	peak	
2	*	2400.000	38.02	13.85	51.87	74.00	-22.13	peak	

Vertical

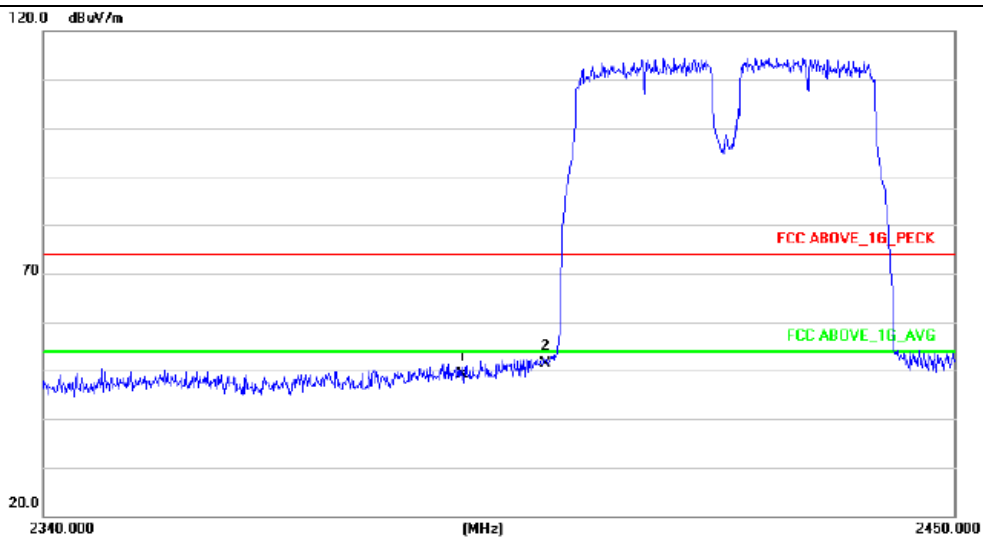

No.	Mk.	Freq.	Reading Level	Correct Factor	Measurement	Limit	Over	Antenna Height	Table Degree
		MHz	dBuV	dB/m	dBuV/m	dBuV/m	dB	cm	degree
1		2390.020	35.28	13.83	49.11	74.00	-24.89	peak	
2	*	2400.050	37.52	13.85	51.37	74.00	-22.63	peak	



**Horizontal 2462**

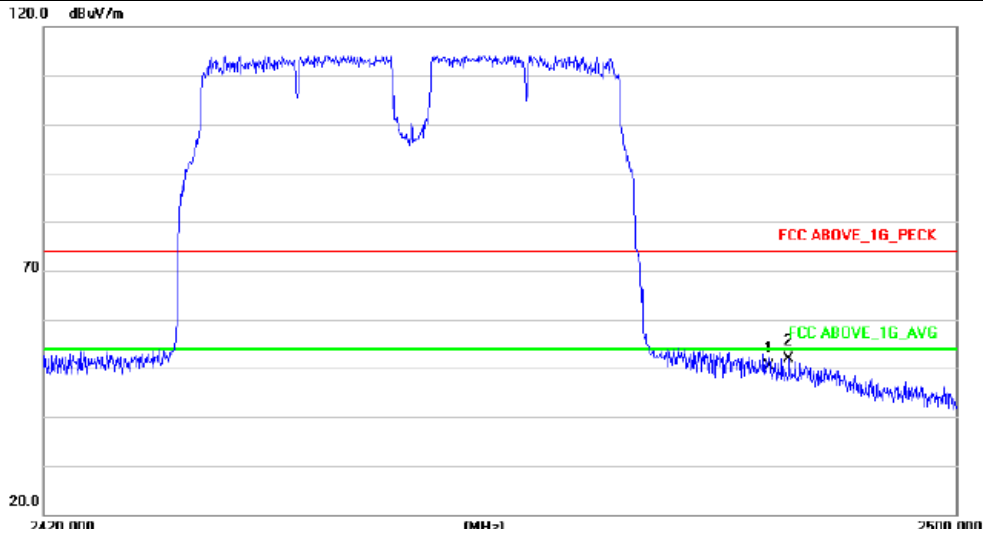

No.	Mk.	Freq.	Reading Level	Correct Factor	Measurement	Limit	Over	Antenna Height	Table Degree	
		MHz	dBuV	dB/m	dBuV/m	dBuV/m	dB	cm	degree	Comment
1		2483.500	36.33	14.02	50.35	74.00	-23.65	peak		
2	*	2485.200	37.94	14.02	51.96	74.00	-22.04	peak		

**Vertical**

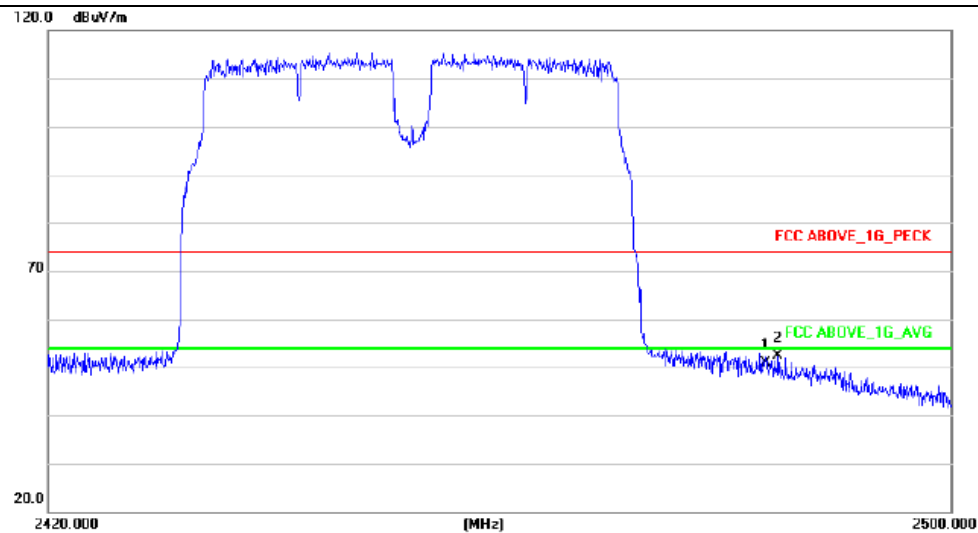

No.	Mk.	Freq.	Reading Level	Correct Factor	Measurement	Limit	Over	Antenna Height	Table Degree	
		MHz	dBuV	dB/m	dBuV/m	dBuV/m	dB	cm	degree	Comment
1		2483.500	36.83	14.02	50.85	74.00	-23.15	peak		
2	*	2484.560	38.47	14.02	52.49	74.00	-21.51	peak		

If the PK measured levels comply with average limit, then the average level were deemed to comply with average limit.

Note: the data of ANT1 only show the worst result.



## 4. POWER SPECTRAL DENSITY TEST

### 4.1 APPLIED PROCEDURES / LIMIT

FCC Part15 (15.247) , Subpart C				
Section	Test Item	Limit	Frequency Range (MHz)	Result
15.247	Power Spectral Density	8 dBm (in any 3KHz)	2400-2483.5	PASS

#### 4.1.1 TEST PROCEDURE

1. Set analyzer center frequency to DTS channel center frequency.
2. Set the span to 1.5 times the DTS bandwidth.
3. Set the RBW to:  $3 \text{ kHz} \leq \text{RBW} \leq 100 \text{ kHz}$ .
4. Set the VBW  $\geq 3 \times \text{RBW}$ .
5. Detector = peak.
6. Sweep time = auto couple.
7. Trace mode = max hold.
8. Allow trace to fully stabilize.
9. Use the peak marker function to determine the maximum amplitude level within the RBW.
10. If measured value exceeds limit, reduce RBW (no less than 3 kHz) and repeat.

#### 4.1.2 DEVIATION FROM STANDARD

No deviation.

#### 4.1.3 TEST SETUP



#### 4.1.4 EUT OPERATION CONDITIONS

The EUT tested system was configured as the statements of 2.1 Unless otherwise a special operating condition is specified in the follows during the testing.



### 4.1.5 TEST RESULTS

EUT :	Wireless Router	Model Name :	Lock 100
Temperature :	25°C	Relative Humidity :	55%
Pressure :	1015 hPa	Test Voltage :	DC 12V From Adapter
Test Mode :	TX b Mode /CH01, CH06, CH11		

Frequency	Power Density (dBm)		Limit (dBm)	Result
	ANT1	ANT2		
2412 MHz	-11.20	-11.65	8	PASS
2437 MHz	-10.97	-11.43	8	PASS
2462 MHz	-11.57	-12.05	8	PASS

Note: the data only show the worst mode.

#### ANT1

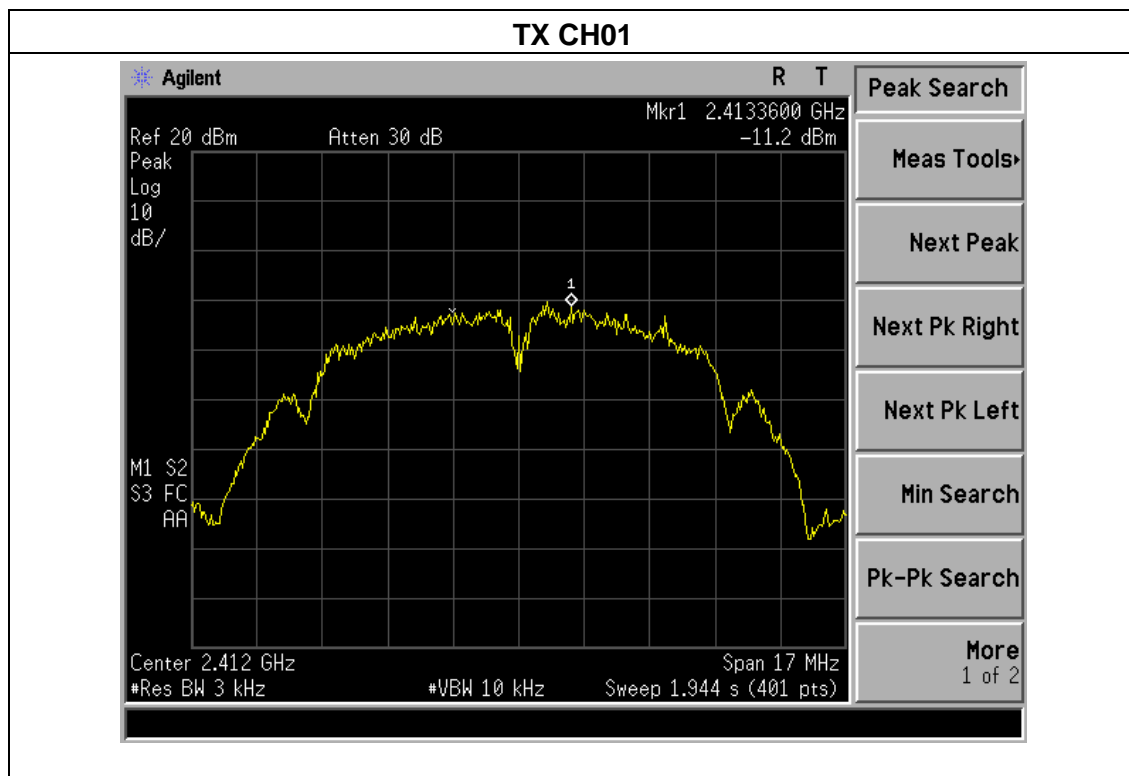

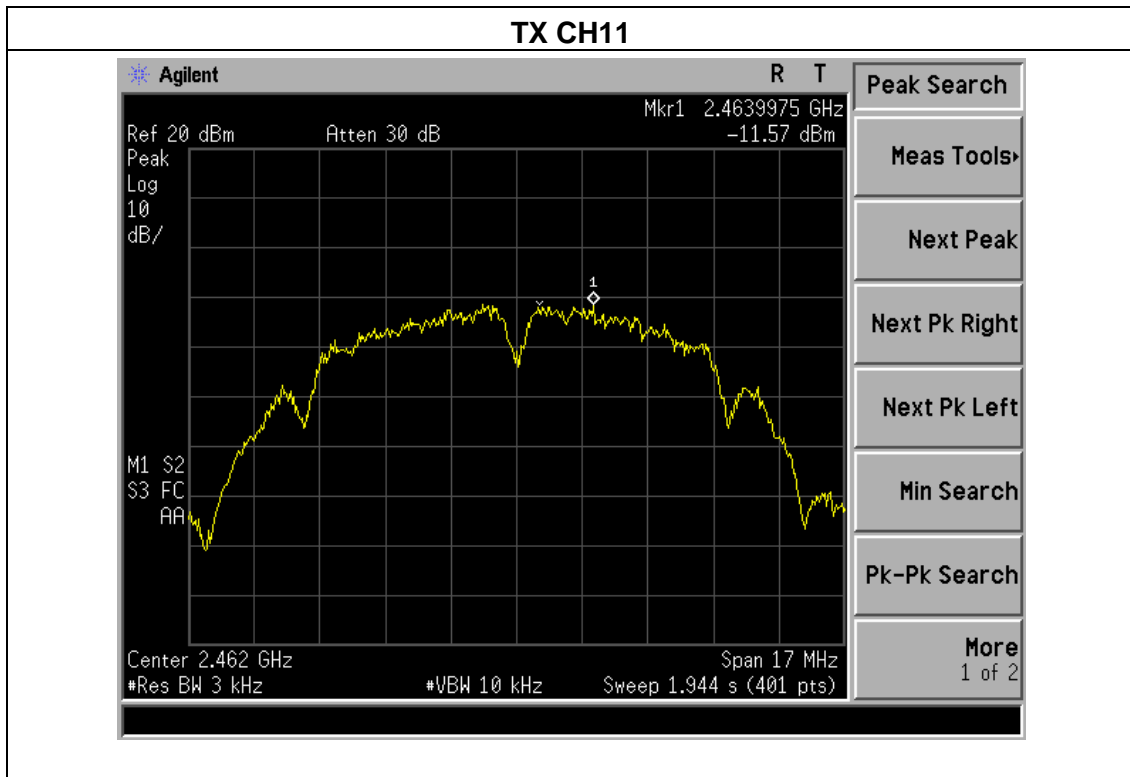
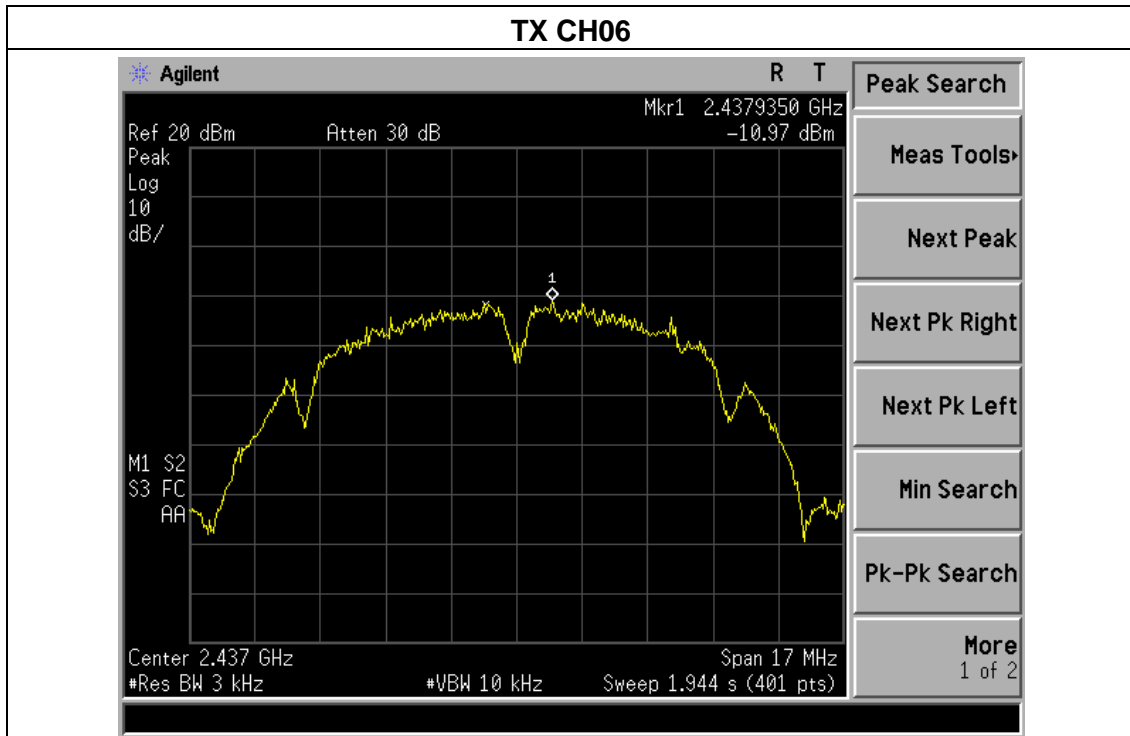





EUT :	Wireless Router	Model Name :	Lock 100
Temperature :	25°C	Relative Humidity :	55%
Pressure :	1015 hPa	Test Voltage :	DC 12V From Adapter
Test Mode :	TX g Mode /CH01, CH06, CH11		

Frequency	Power Density (dBm)		Limit (dBm)	Result
	ANT1	ANT2		
2412 MHz	-13.48	-14.15	8	PASS
2437 MHz	-14.24	-14.52	8	PASS
2462 MHz	-17.47	-17.66	8	PASS

Note: the data only show the worst mode.

**ANT1**

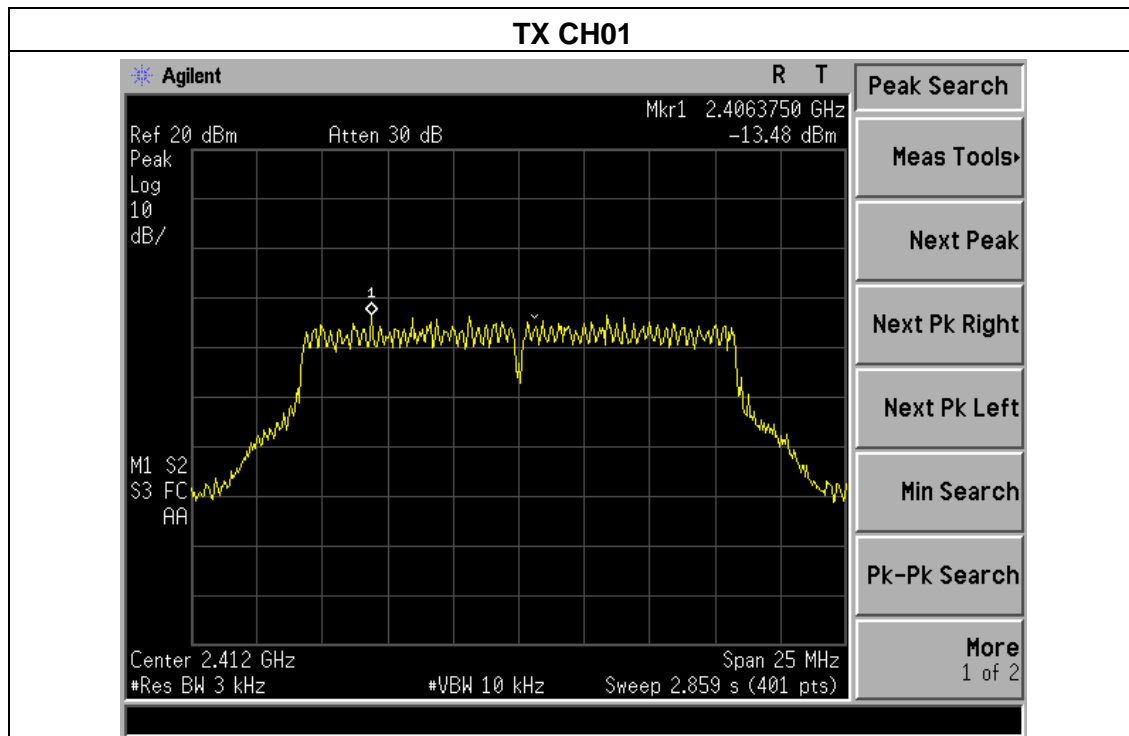

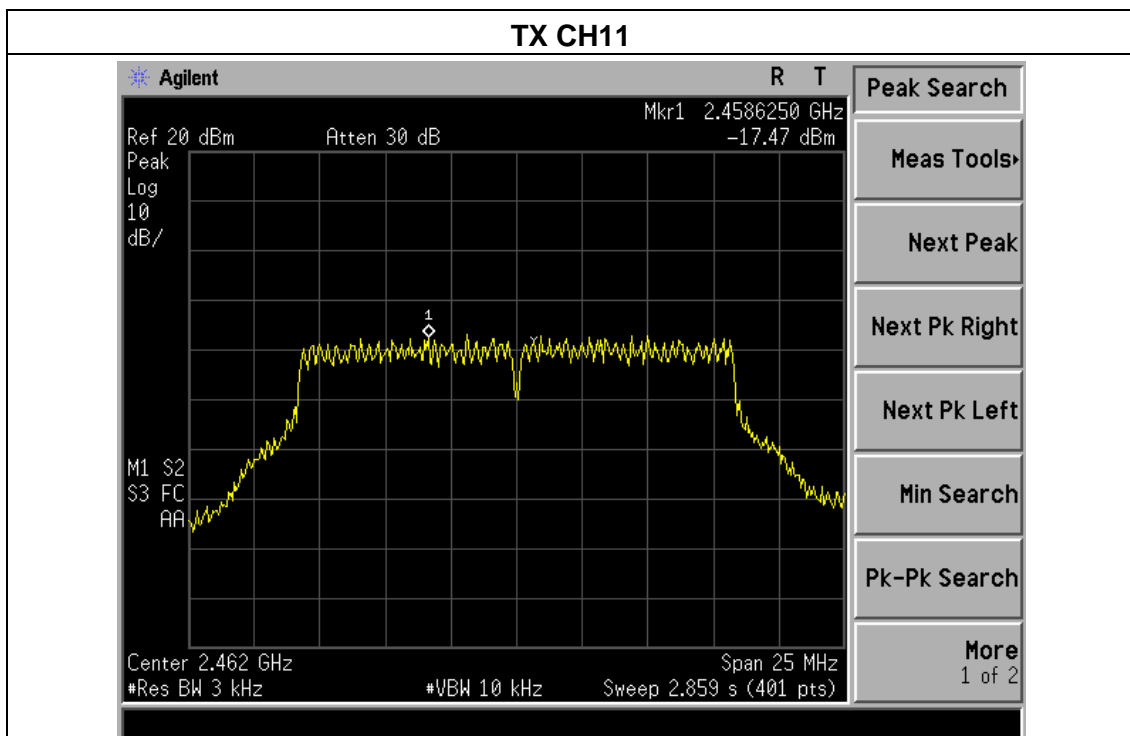
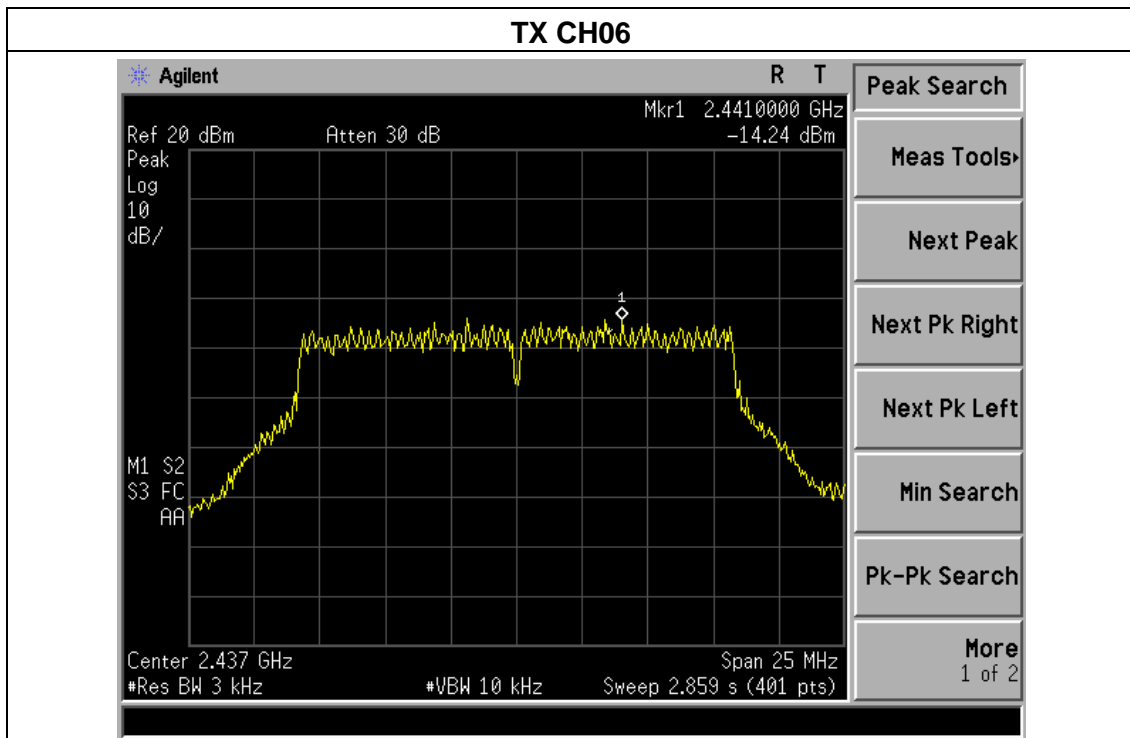



EUT :	Wireless Router	Model Name :	Lock 100
Temperature :	25°C	Relative Humidity :	55%
Pressure :	1015 hPa	Test Voltage :	DC 12V From Adapter
Test Mode :	TX n Mode(20M) /CH01, CH06, CH11		

Frequency	Power Density (dBm)		Limit (dBm)	Result
	Ant1	Ant2		
2412 MHz	-15.10	-16.25	8	PASS
2437 MHz	-15.66	-16.33	8	PASS
2462 MHz	-15.49	-16.45	8	PASS

Note: the data only show the worst mode.

ANT1

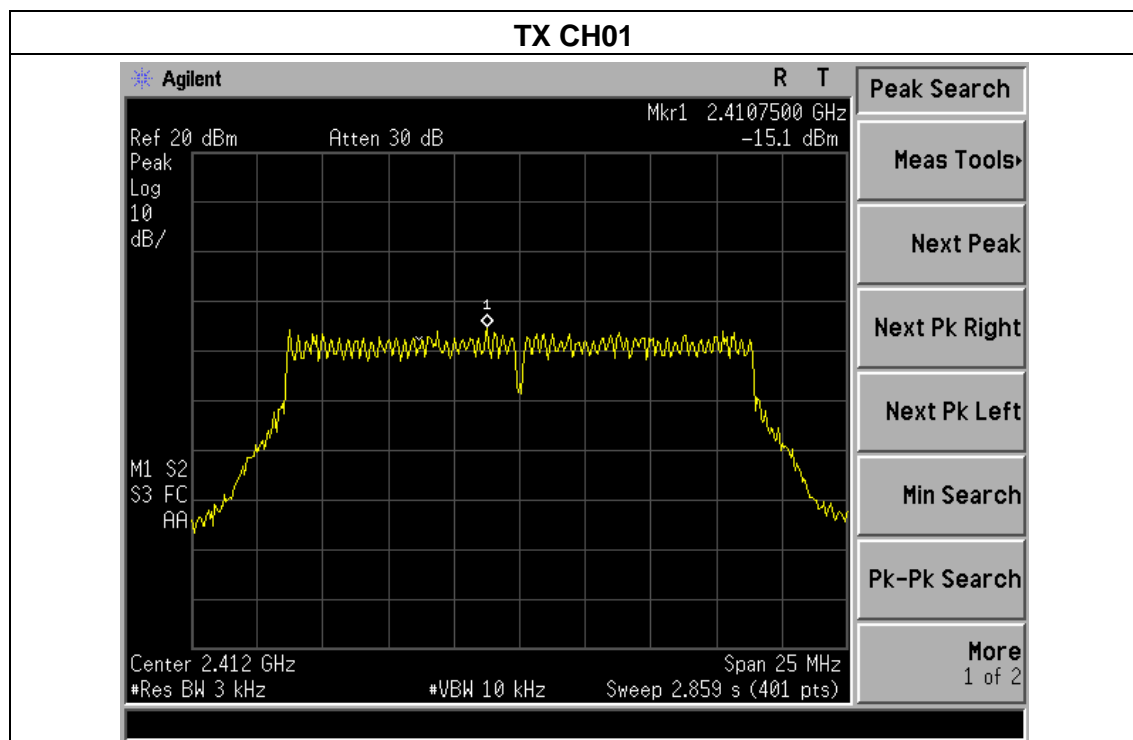

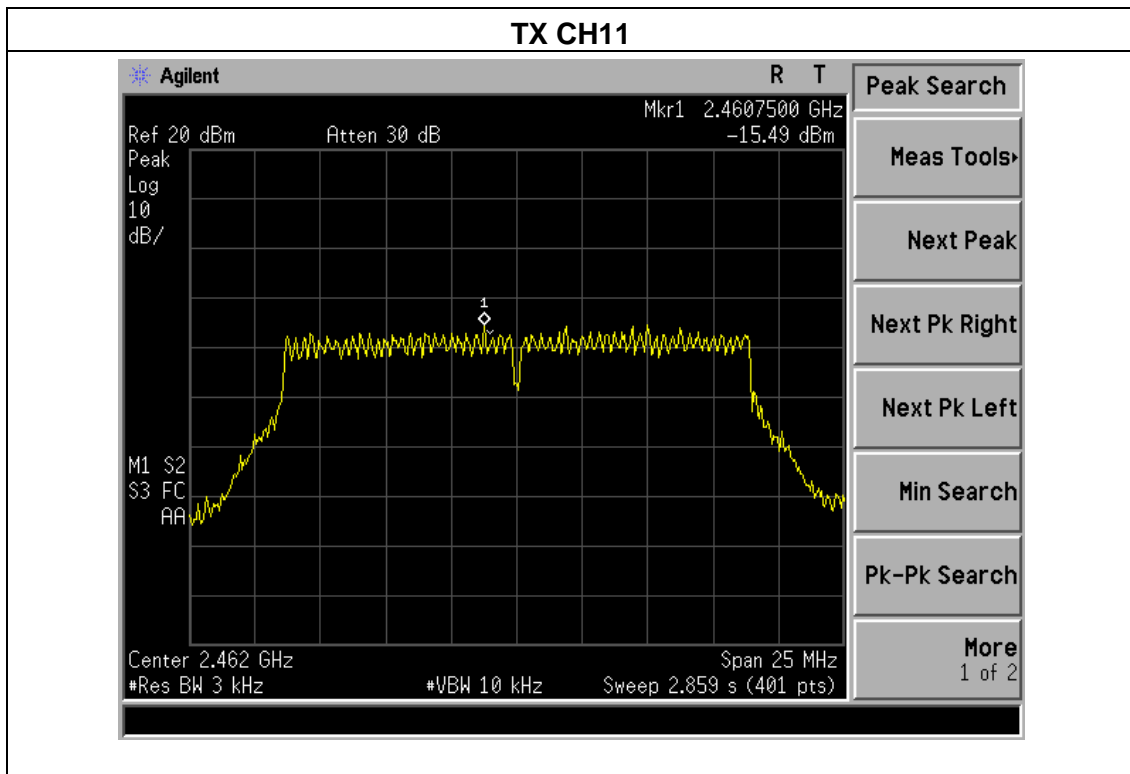
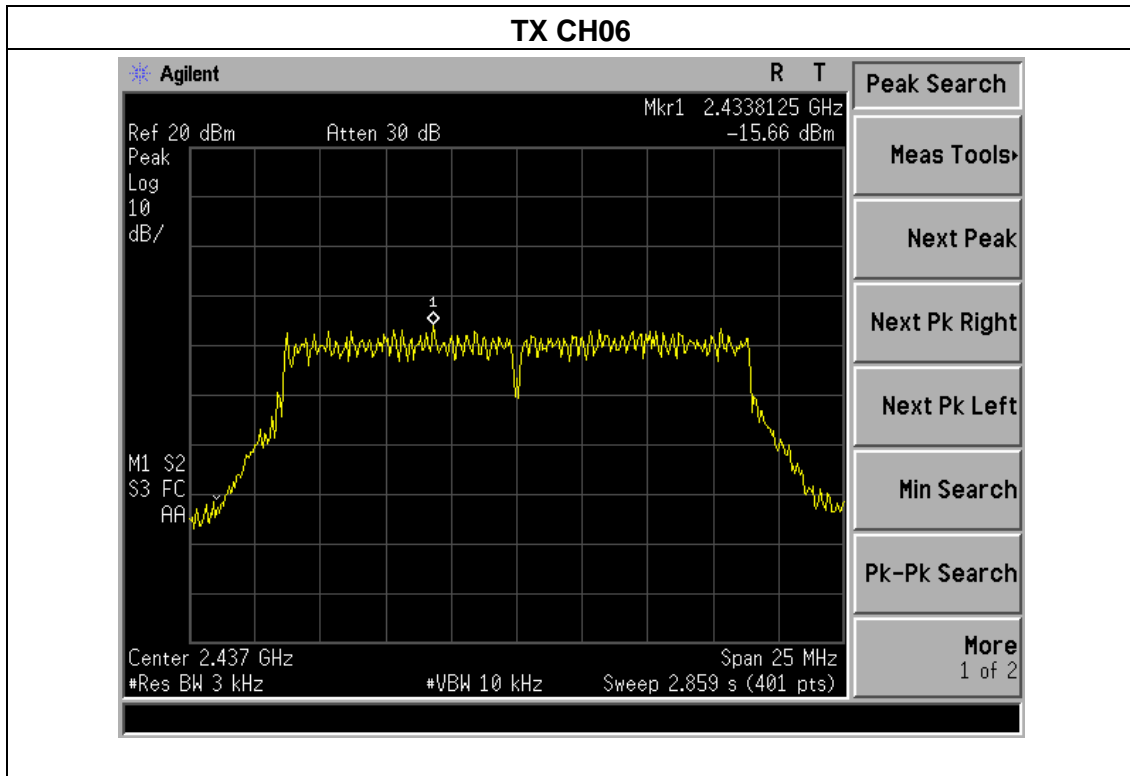



EUT :	Wireless Router	Model Name :	Lock 100
Temperature :	25°C	Relative Humidity :	55%
Pressure :	1015 hPa	Test Voltage :	DC 12V From Adapter
Test Mode :	TX n Mode(40M) /CH03, CH06, CH09		

Frequency	Power Density (dBm)		Limit (dBm)	Result
	Ant1	Ant2		
2422 MHz	-32.15	-33.55	8	PASS
2437 MHz	-30.30	-32.86	8	PASS
2452 MHz	-33.65	-33.77	8	PASS

Note: the data only show the worst mode.

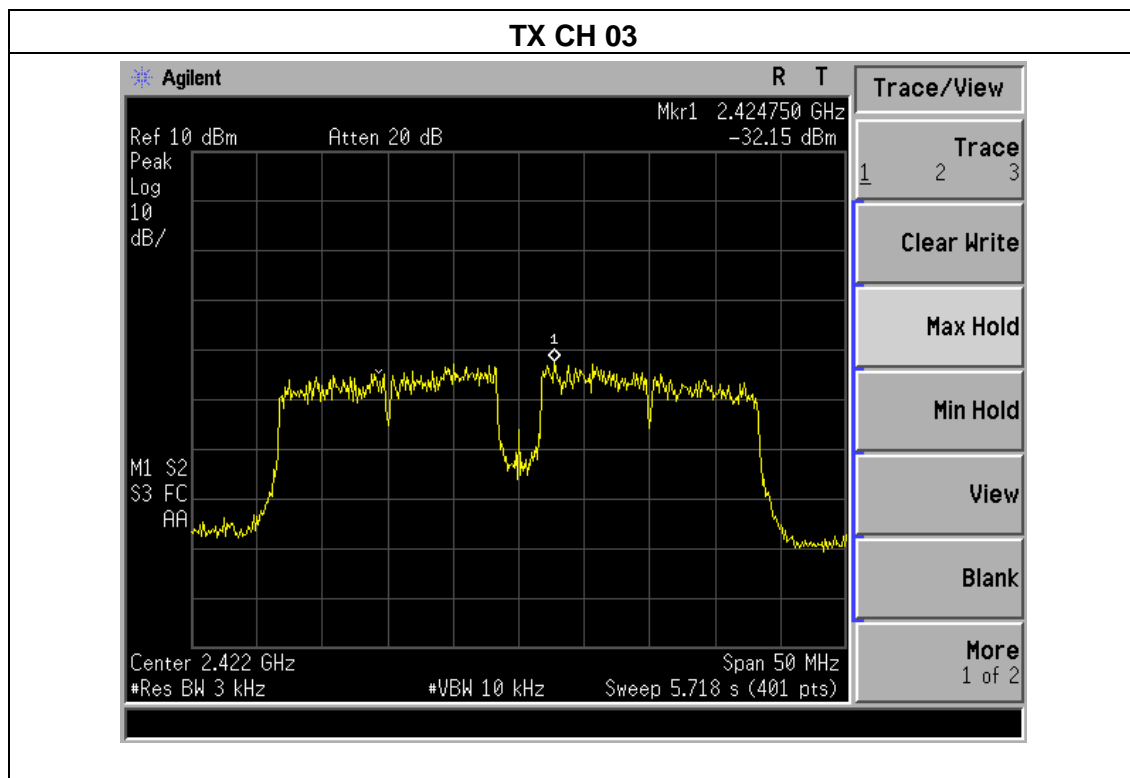



### TX CH 06

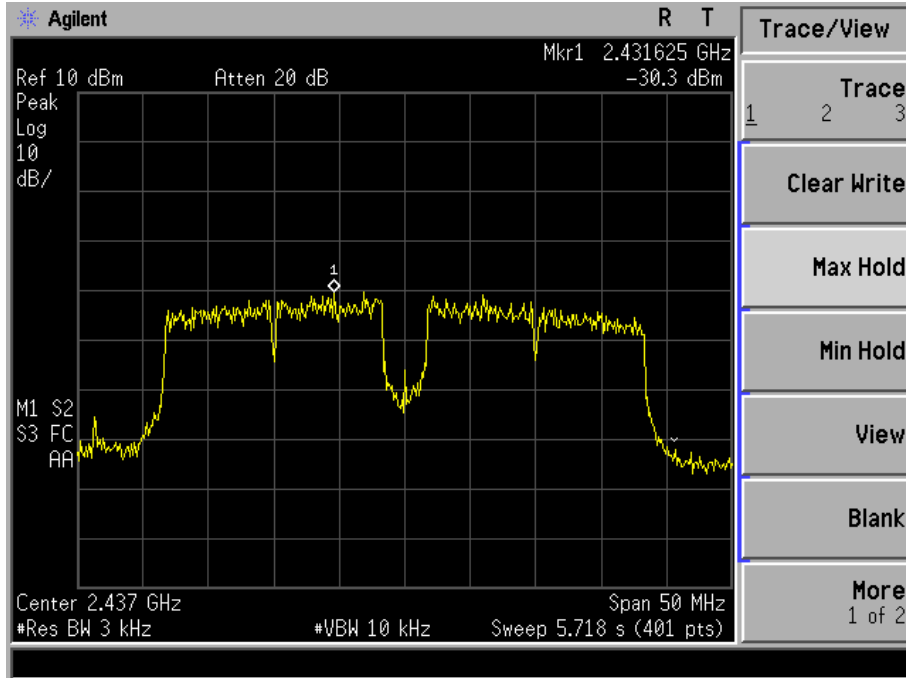

### TX CH 09

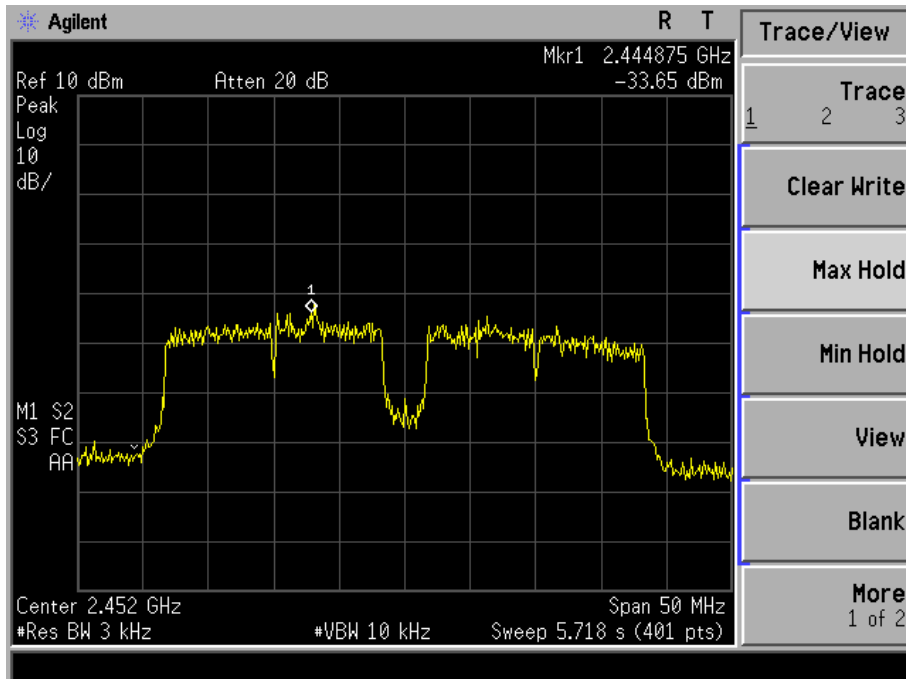



## 5. BANDWIDTH TEST

### 5.1 APPLIED PROCEDURES / LIMIT

FCC Part15 (15.247) , Subpart C				
Section	Test Item	Limit	Frequency Range (MHz)	Result
15.247(a)(2)	Bandwidth	$\geq 500\text{KHz}$ (6dB bandwidth)	2400-2483.5	PASS

#### 5.1.1 TEST PROCEDURE

1. Set RBW = 100 kHz.
2. Set the video bandwidth (VBW)  $\geq 3 \times$  RBW.
3. Detector = Peak.
4. Trace mode = max hold.
5. Sweep = auto couple.
6. Allow the trace to stabilize.
7. Measure the maximum width of the emission that is constrained by the frequencies associated with the two outermost amplitude points (upper and lower frequencies) that are attenuated by 6 dB relative to the maximum level measured in the fundamental emission.

#### 5.1.2 DEVIATION FROM STANDARD

No deviation.

#### 5.1.3 TEST SETUP



#### 5.1.4 EUT OPERATION CONDITIONS

The EUT tested system was configured as the statements of 2.4 Unless otherwise a special operating condition is specified in the follows during the testing.



5.1.5 TEST RESULTS

EUT :	Wireless Router	Model Name :	Lock 100
Temperature :	25°C	Relative Humidity :	55%
Pressure :	1012 hPa	Test Voltage :	DC 12V From Adapter
Test Mode :	TX b Mode /CH01, CH06, CH11		

Channel	Frequency (MHz)	6dB bandwidth (MHz)		Limit (kHz)	Result
		ANT1	ANT2		
Low	2412	8.083	8.032	500	Pass
Middle	2437	8.076	8.051	500	Pass
High	2462	8.117	8.112	500	Pass

Note: the data only show the worst mode.

ANT1

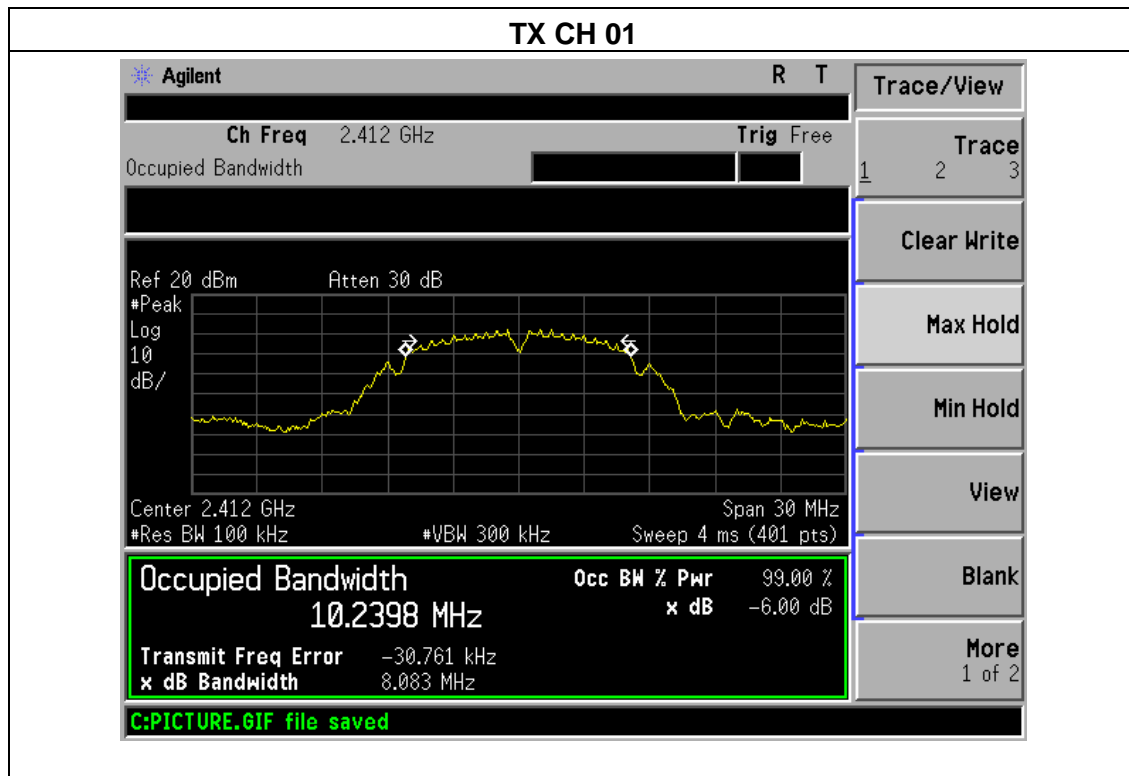



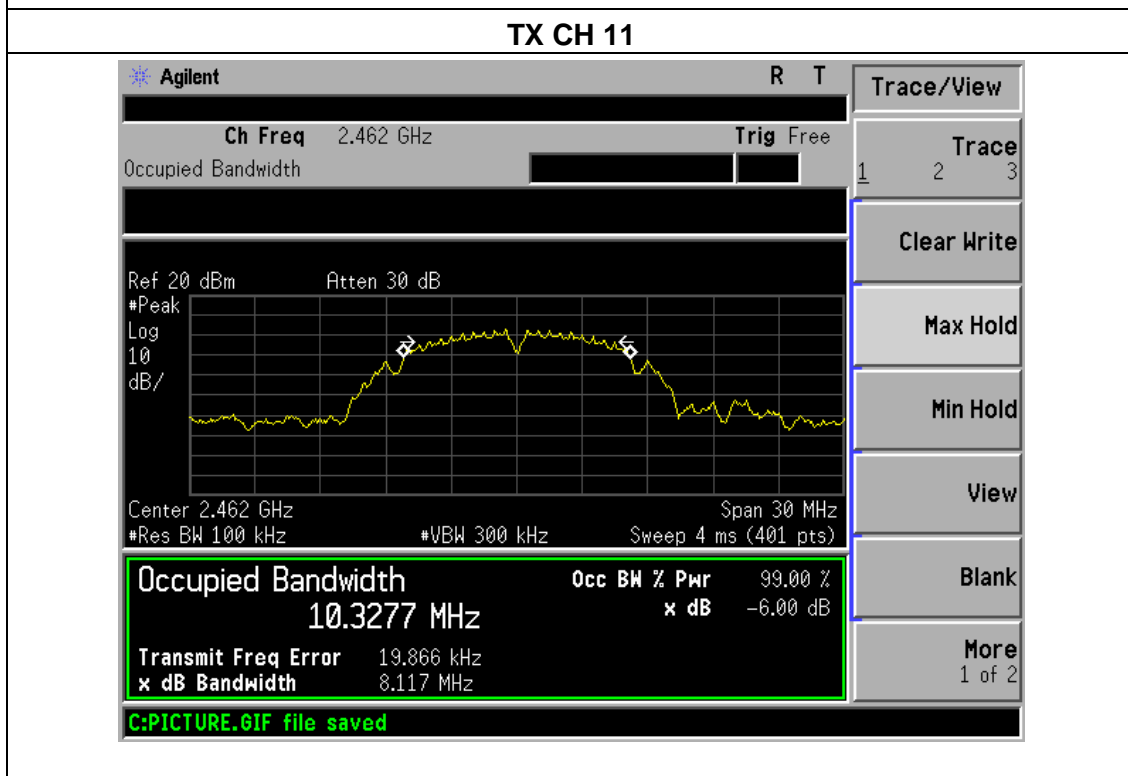
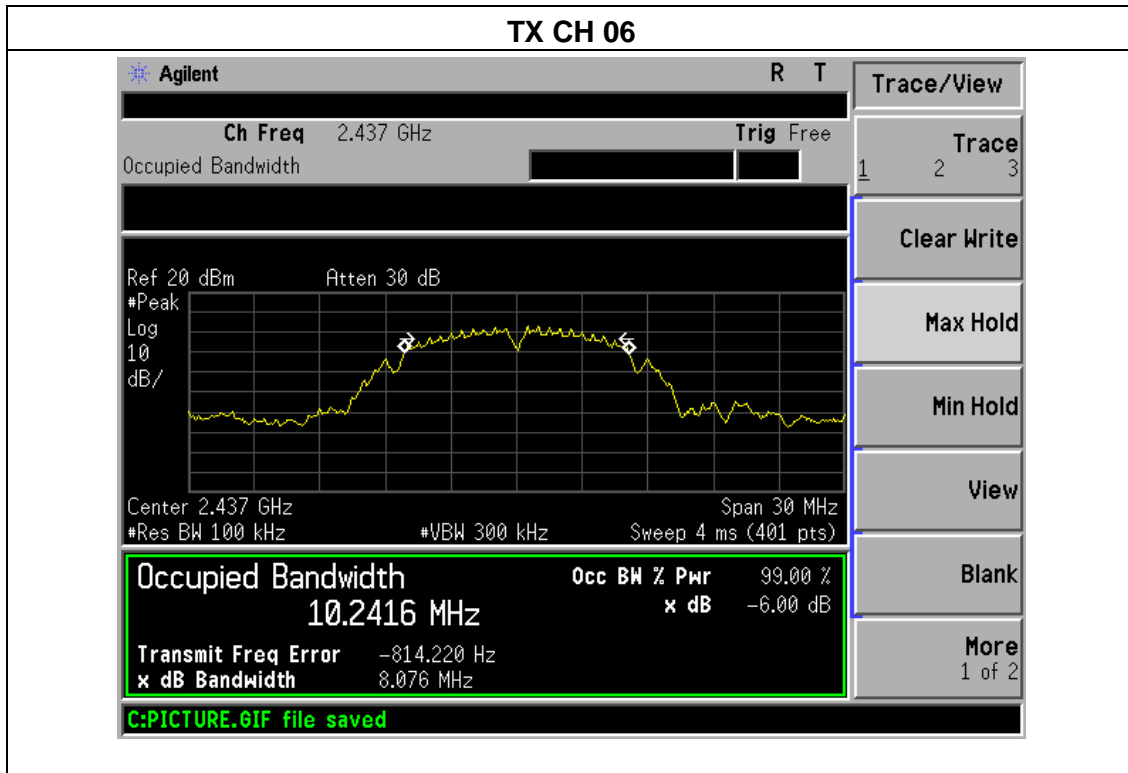



EUT :	Wireless Router	Model Name :	Lock 100
Temperature :	25°C	Relative Humidity :	55%
Pressure :	1012 hPa	Test Voltage :	DC 12V From Adapter
Test Mode :	TX g Mode /CH01, CH06, CH11		

Channel	Frequency (MHz)	6dB bandwidth (MHz)		Limit (kHz)	Result
		ANT1	ANT2		
Low	2412	16.450	16.415	500	Pass
Middle	2437	16.436	16.421	500	Pass
High	2462	16.413	15.956	500	Pass

Note: the data only show the worst mode.

**ANT1**

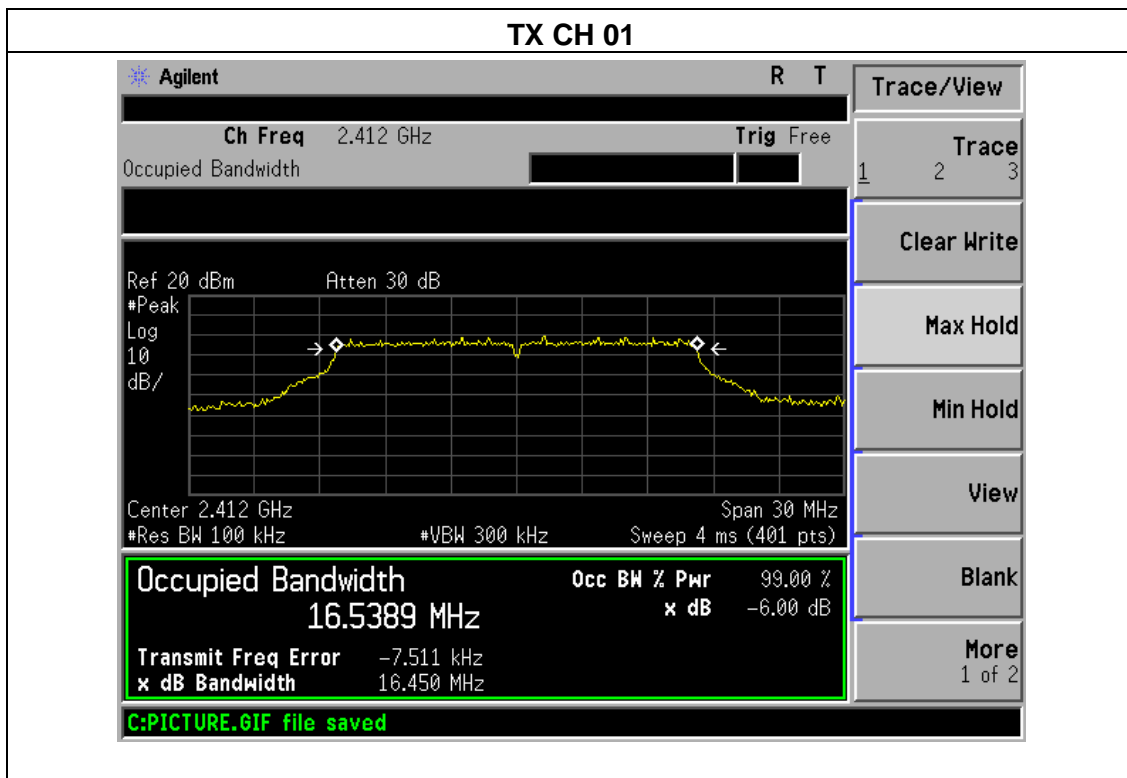

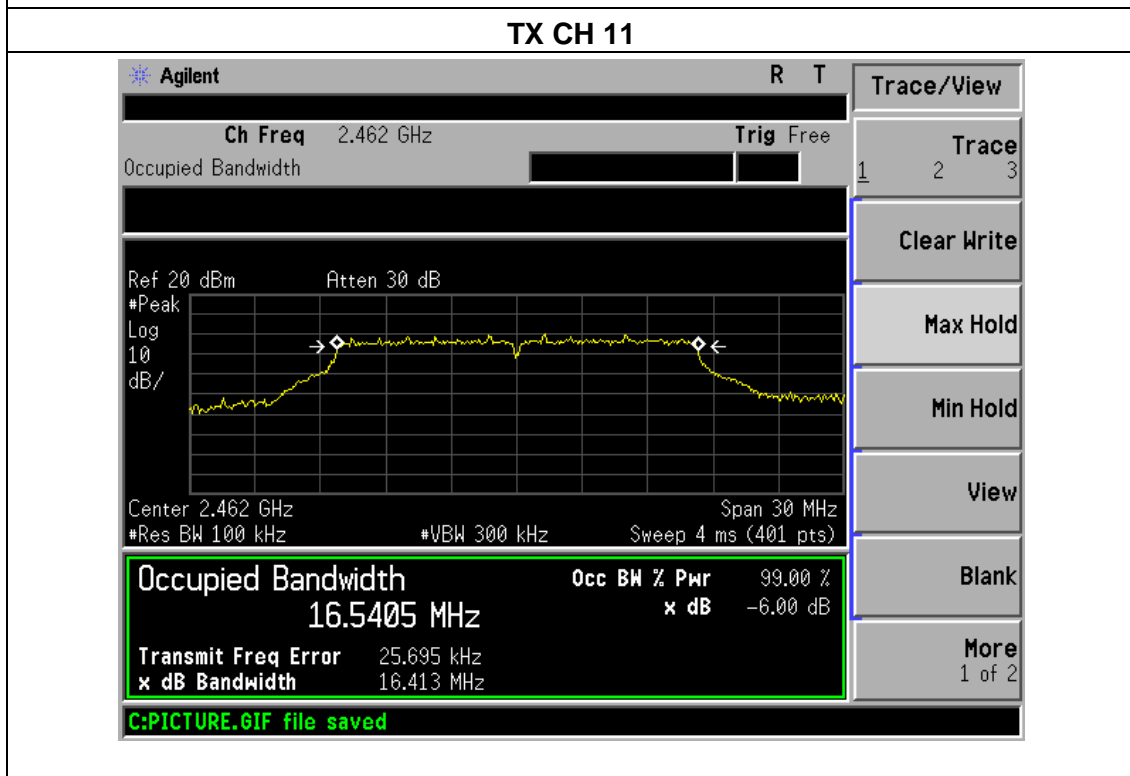
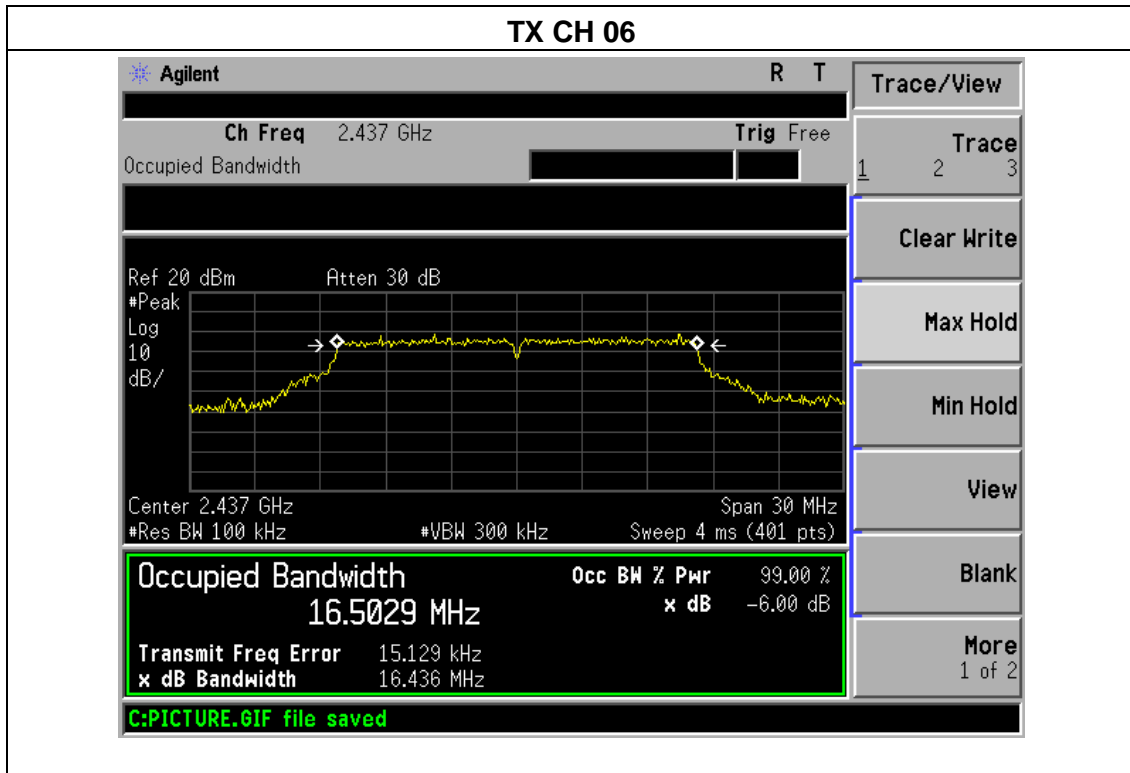



EUT :	Wireless Router	Model Name :	Lock 100
Temperature :	25°C	Relative Humidity :	55%
Pressure :	1012 hPa	Test Voltage :	DC 12V From Adapter
Test Mode :	TX n Mode(20M) /CH01, CH06, CH11		

Channel	Frequency (MHz)	6dB bandwidth (MHz)		Limit (kHz)	Result
		ANT1	ANT2		
Low	2412	17.602	17.335	500	Pass
Middle	2437	17.632	17.328	500	Pass
High	2462	17.624	17.453	500	Pass

Note: the data only show the worst mode.

**ANT1**

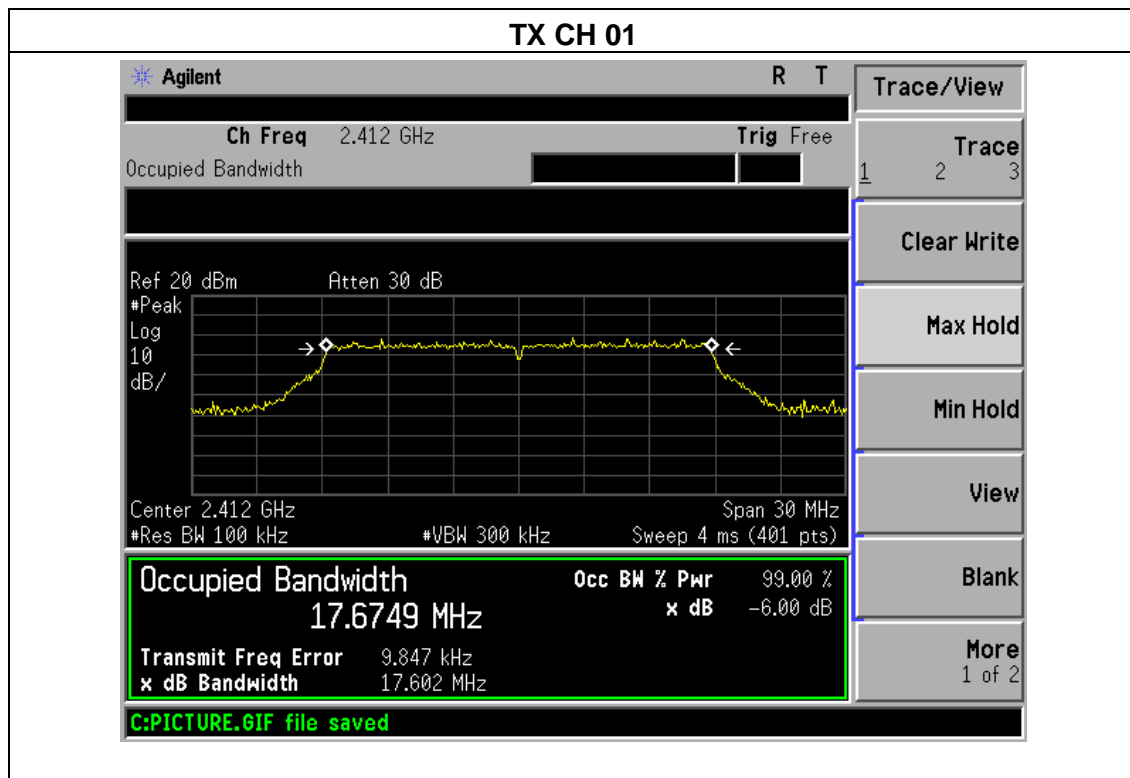

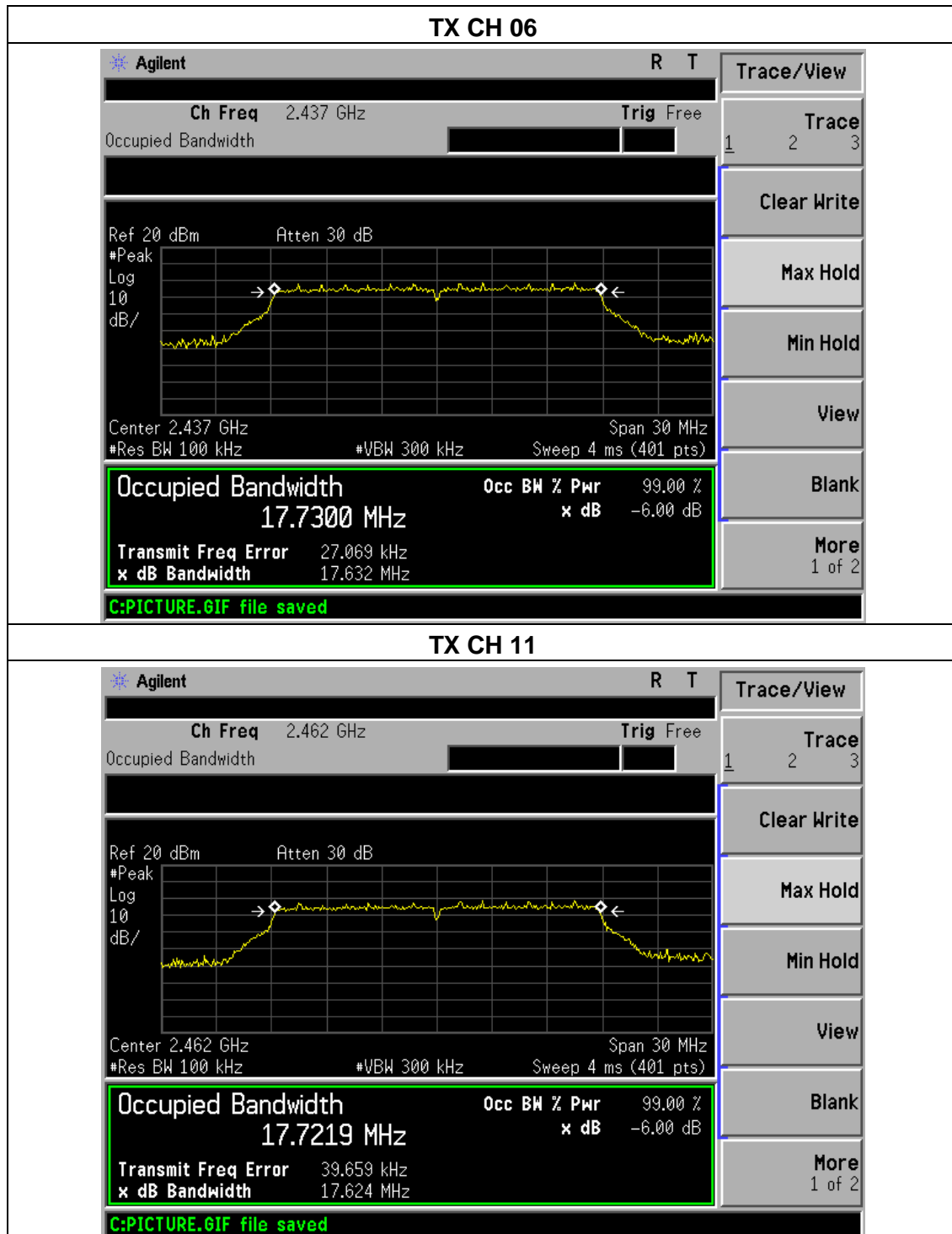



EUT :	Wireless Router	Model Name :	Lock 100
Temperature :	25°C	Relative Humidity :	55%
Pressure :	1012 hPa	Test Voltage :	DC 12V From Adapter
Test Mode :	TX n Mode(40M) /CH03, CH06, CH09		

Channel	Frequency (MHz)	6dB bandwidth (MHz)		Limit (kHz)	Result
		ANT1	ANT2		
Low	2422	34.204	34.117	500	Pass
Middle	2437	35.156	34.865	500	Pass
High	2452	35.100	35.055	500	Pass

Note: the data only show the worst mode.

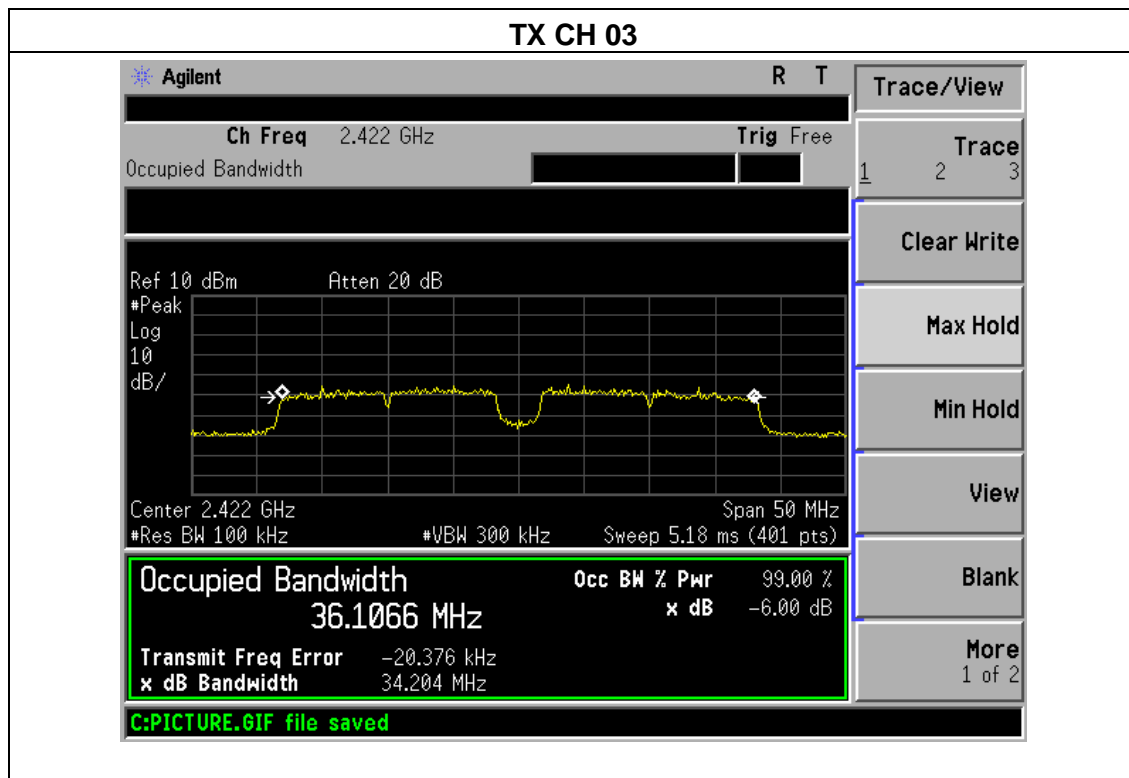

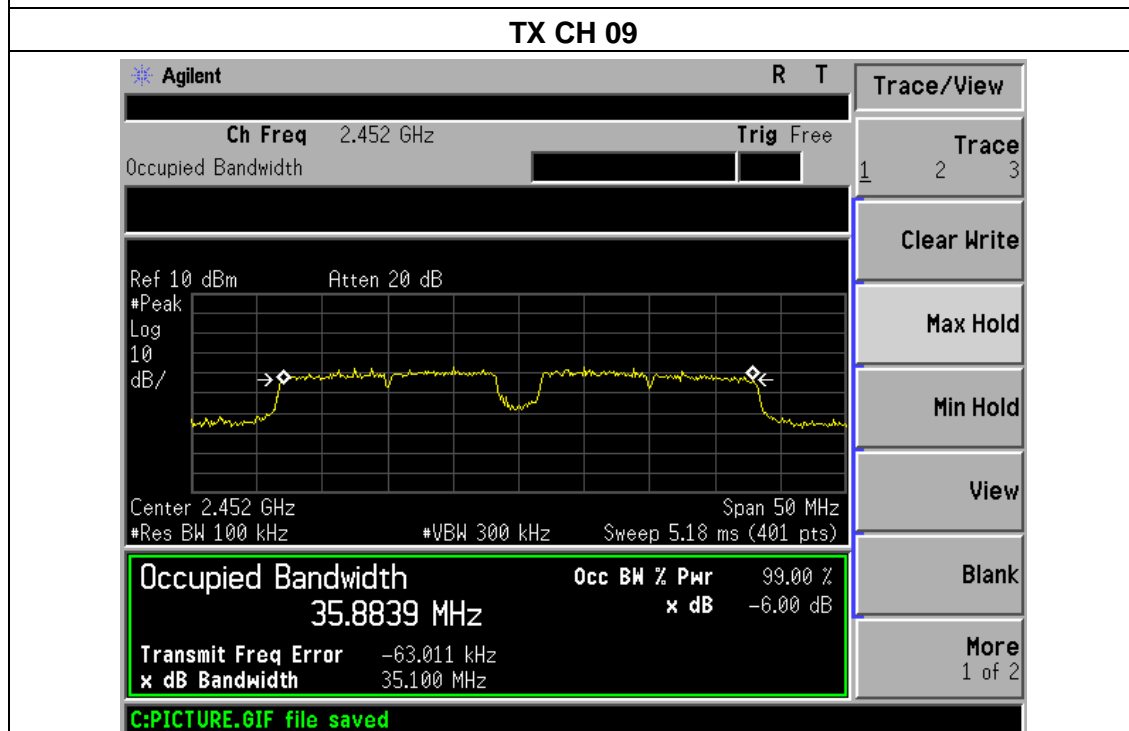
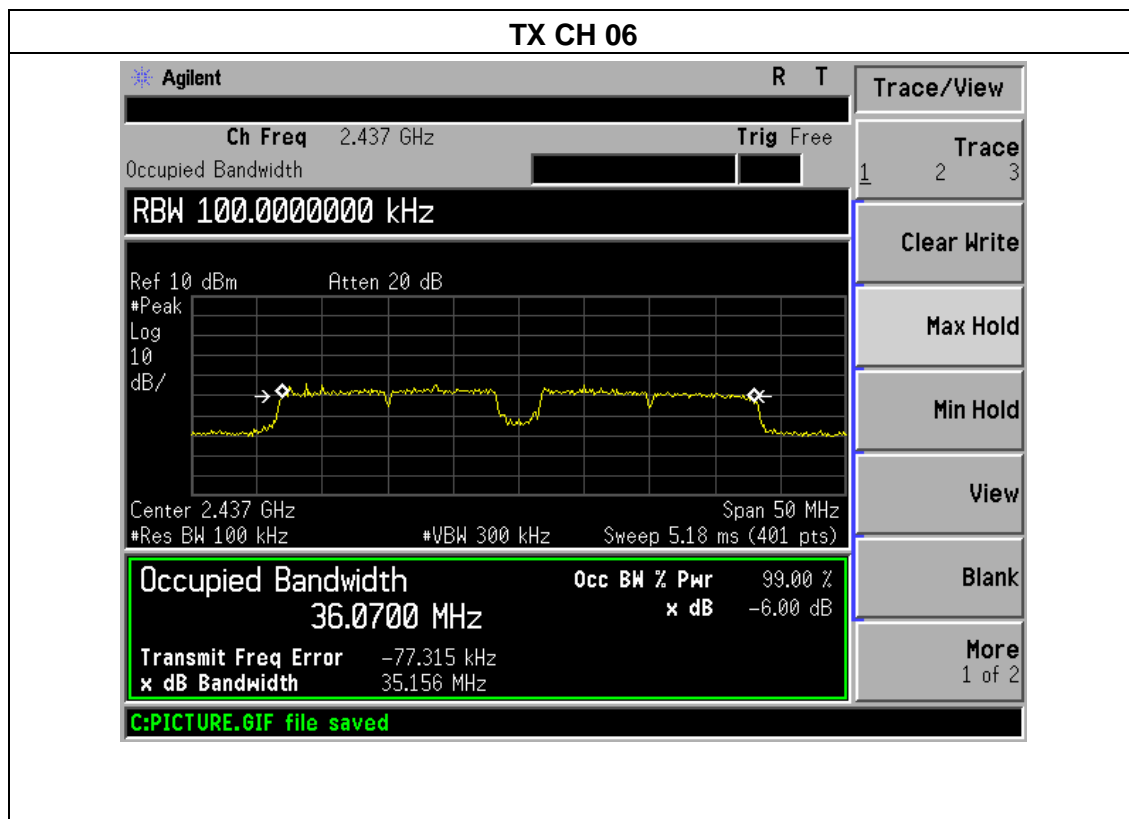



## 6. PEAK OUTPUT POWER TEST

### 6.1 APPLIED PROCEDURES / LIMIT

FCC Part15 (15.247) , Subpart C				
Section	Test Item	Limit	Frequency Range (MHz)	Result
15.247(b)(3)	Peak Output Power	1 watt or 30dBm	2400-2483.5	PASS

#### 6.1.1 TEST PROCEDURE

- a. The EUT was directly connected to the Power meter

#### 6.1.2 DEVIATION FROM STANDARD

No deviation.

#### 6.1.3 TEST SETUP



#### 6.1.4 EUT OPERATION CONDITIONS

The EUT tested system was configured as the statements of 2.4 Unless otherwise a special operating condition is specified in the follows during the testing.





**6.1.5 TEST RESULTS**

EUT :	Wireless Router	Model Name :	Lock 100
Temperature :	25°C	Relative Humidity :	55%
Pressure :	1012 hPa	Test Voltage :	DC 12V From Adapter
Test Mode :	TX b/g/n(20M, 40M)		

<b>TX 802.11b Mode</b>				
Test Channe	Frequency (MHz)	Maximum Conducted Output Power(PK)		LIMIT
		(dBm)		
		ANT1	ANT2	dBm
CH01	2412	15.85	13.55	30
CH06	2437	15.67	13.43	30
CH11	2462	15.59	13.25	30
<b>TX 802.11g Mode</b>				
CH01	2412	14.76	12.65	30
CH06	2437	14.55	12.45	30
CH11	2462	14.48	12.52	30
<b>TX 802.11n-HT20 Mode</b>				
CH01	2412	12.83	10.67	30
CH06	2437	12.74	10.50	30
CH11	2462	12.52	10.34	30
<b>TX 802.11n-HT40 Mode</b>				
CH03	2422	11.59	9.44	30
CH06	2437	11.45	9.33	30
CH09	2452	11.32	9.21	30



## 7. 100 KHZ BANDWIDTH OF FREQUENCY BAND EDGE

### APPLICABLE STANDARD

In any 100 kHz bandwidth outside the frequency band in which the spread spectrum or digitally modulated intentional radiator is operating, the radio frequency power that is produced by the intentional radiator shall be at least 20 dB below that in the 100 kHz bandwidth within the band that contains the highest level of the desired power, based on either an RF conducted or a radiated measurement, provided the transmitter demonstrates compliance with the peak conducted power limits. If the transmitter complies with the conducted power limits based on the use of RMS averaging over a time interval, as permitted under paragraph (b)(3) of this section, the attenuation required under this paragraph shall be 30 dB instead of 20 dB. Attenuation below the general limits specified in §15.209(a) is not required. In addition, radiated emissions which fall in the restricted bands, as defined in §15.205(a), must also comply with the radiated emission limits specified in §15.209(a) (see §15.205(c)).

### TEST PROCEDURE

- a) Check the calibration of the measuring instrument using either an internal calibrator or a known signal from an external generator.
- b) Position the EUT without connection to measurement instrument. Turn on the EUT and connect its antenna terminal to measurement instrument via a low loss cable. Then set it to any one measured frequency within its operating range, and make sure the instrument is operated in its linear range.
- c) Set RBW to 100 kHz and VBW of spectrum analyzer to 300 kHz with a convenient frequency span including 100 kHz bandwidth from band edge.
- d) Measure the highest amplitude appearing on spectral display and set it as a reference level. Plot the graph with marking the highest point and edge frequency.
- e) Repeat above procedures until all measured frequencies were complete.

### 7.1 DEVIATION FROM STANDARD

No deviation.



## 7.2 TEST SETUP



## 7.3 EUT OPERATION CONDITIONS

The EUT tested system was configured as the statements of 2.4 Unless otherwise a special operating condition is specified in the follows during the testing.



## 7.4 TEST RESULTS

EUT :	Wireless Router	Model Name :	Lock 100
Temperature :	25°C	Relative Humidity :	55%
Pressure :	1012 hPa	Test Voltage :	DC 12V From Adapter

Frequency Band	Delta Peak to band emission (dBc)		> Limit (dBc)	Result
	ANT1	ANT2		
802.11b mode				
Left-band	43.31	42.62	20	Pass
Right-band	48.71	47.58	20	Pass
802.11g mode				
Left-band	28.74	27.86	20	Pass
Right-band	32.99	31.57	20	Pass
802.11n-HT20 mode				
Left-band	33.09	30.85	20	Pass
Right-band	35.56	34.89	20	Pass
802.11n-HT40 mode				
Left-band	25.71	24.64	20	Pass
Right-band	30.46	29.82	20	Pass

Note: the data only show the worst mode.



ANT1

802.11b: Band Edge, Left Side

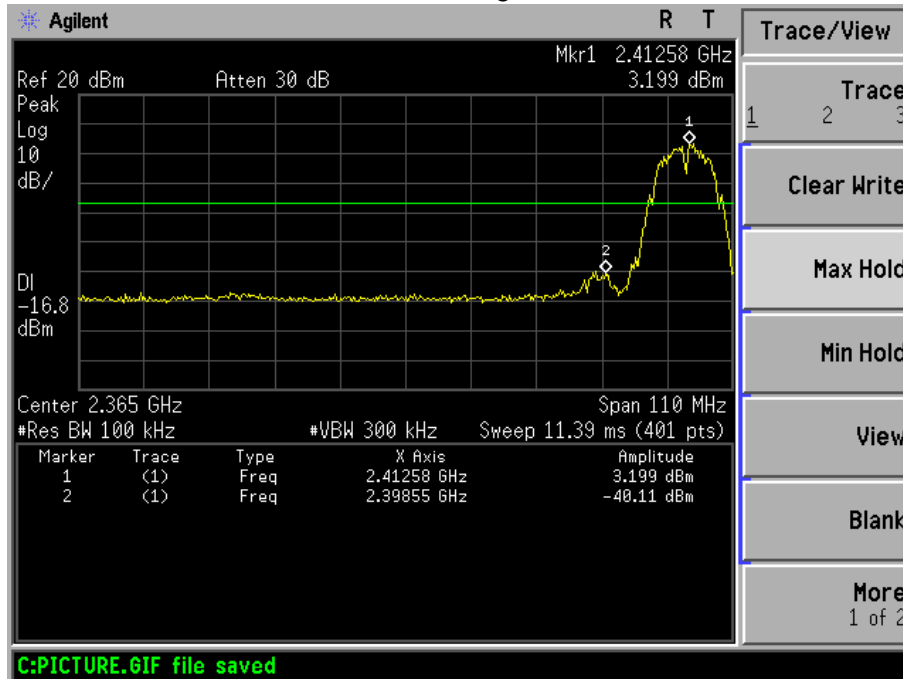

802.11b: Band Edge, Right Side

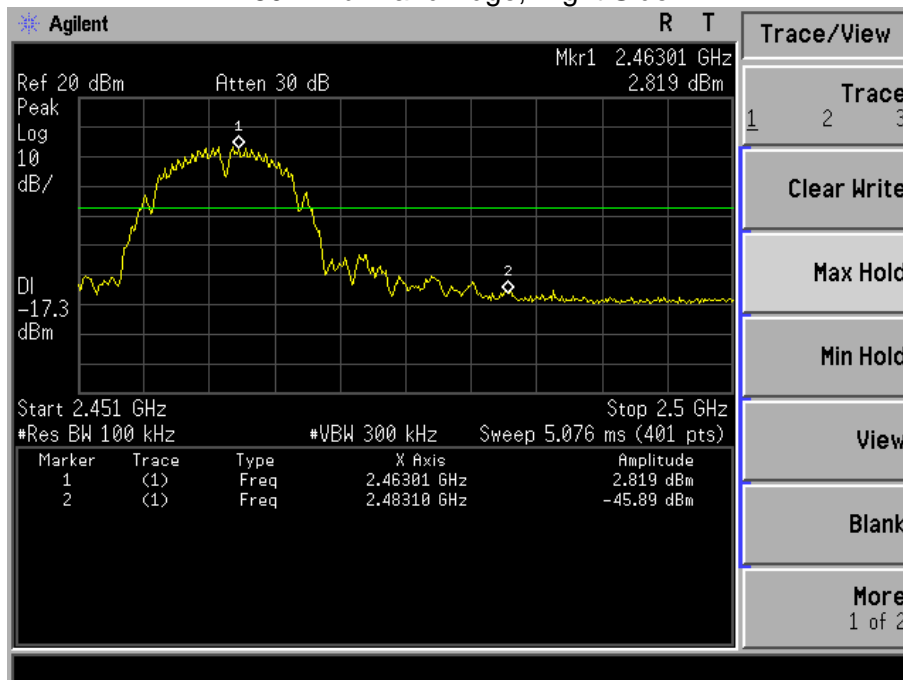



### 802.11g: Band Edge, Left Side

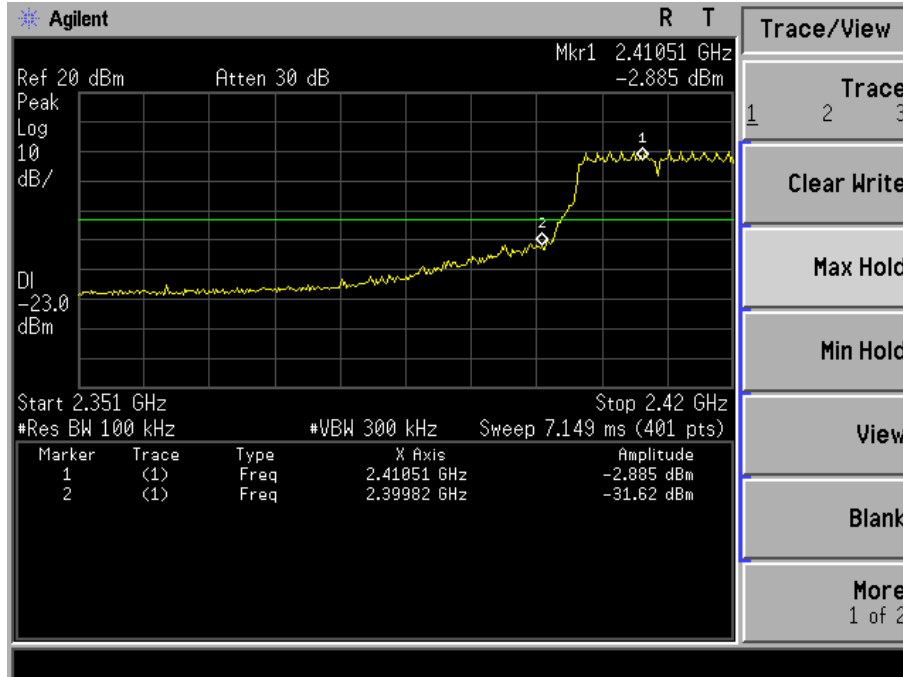

### 802.11g: Band Edge, Right Side

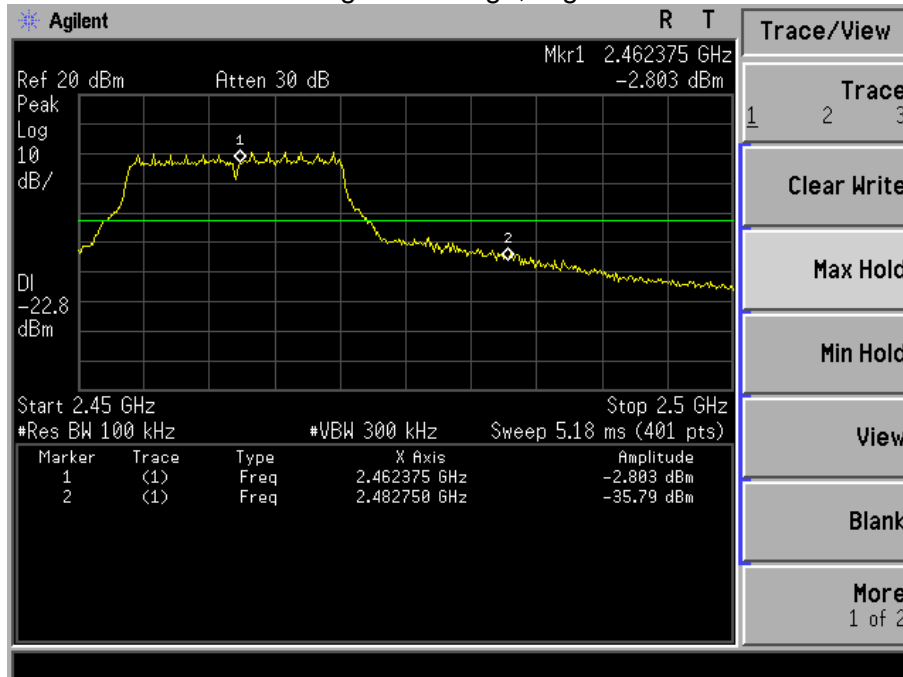



### 802.11n-HT20: Band Edge, Left Side

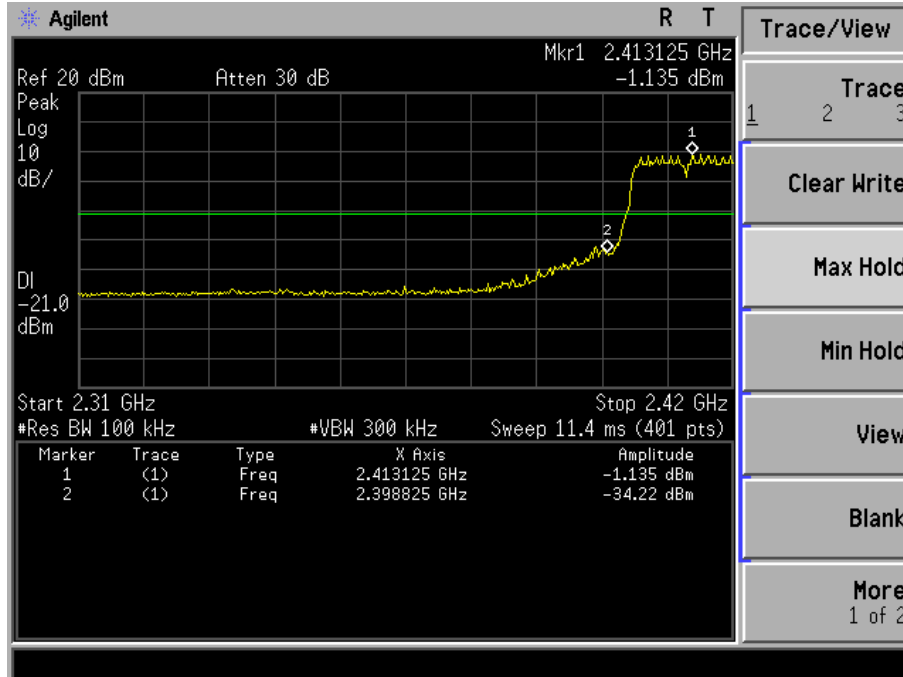

### 802.11n-HT20: Band Edge, Right Side

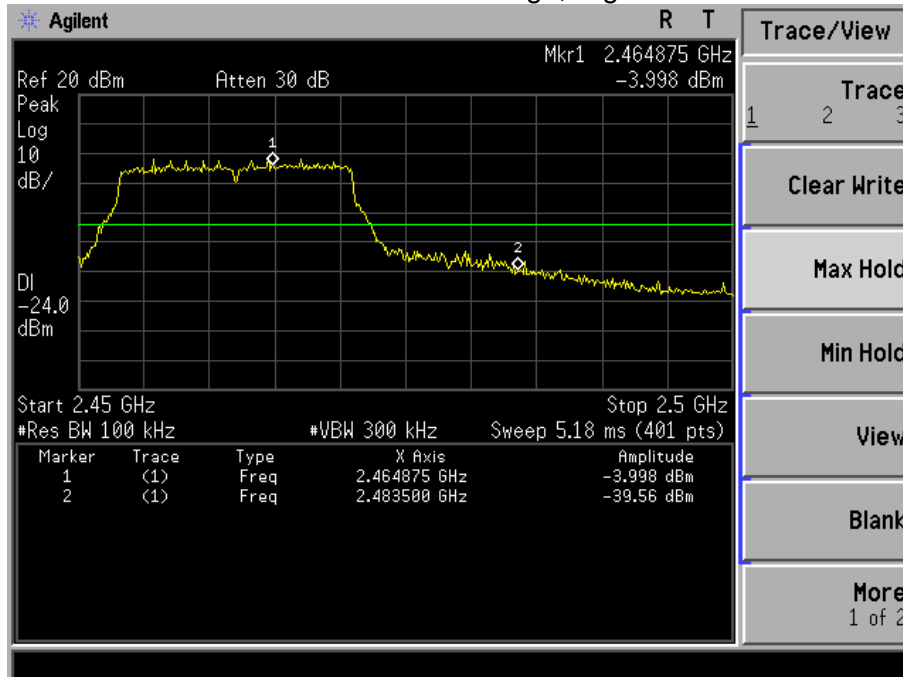



802.11n-HT40

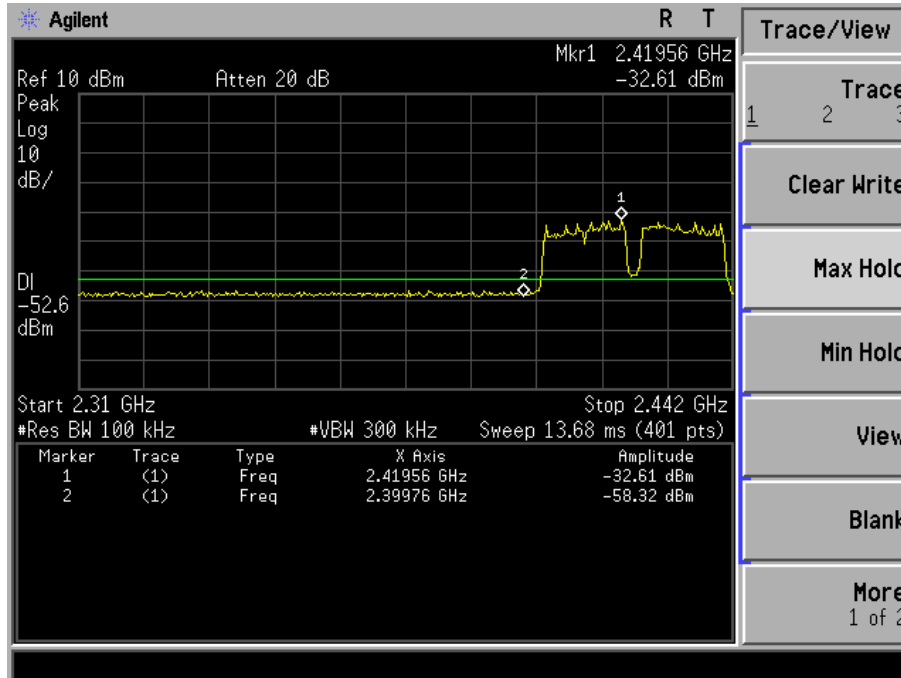

802.11n-HT40

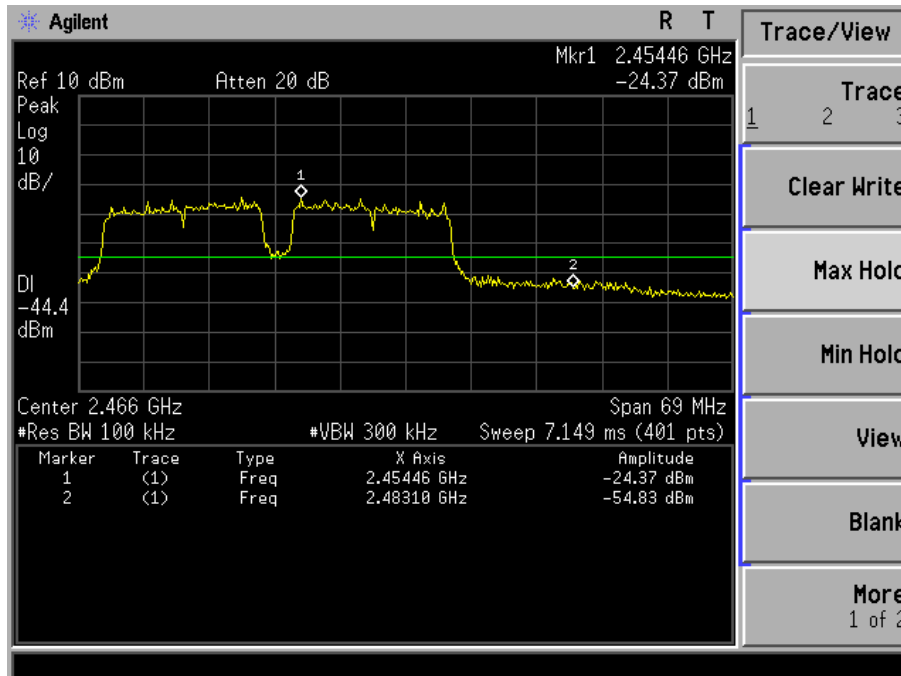





## 8. DUTY CYCLE OF TEST SIGNAL

### 8.1 STANDARD REQUIREMENT

Pre-analysis Check: While conducting average power measurement, duty cycle of each mode shall be checked to ensure its duty cycle in order to compensate for the loss due to insufficient ratio of duty cycle.

All duty cycle is pre-scanned, and result as obtained below shows only the most representative ones where duty cycle is conducted as the given transmission with given virtual operation that expresses the percentage.

### 8.2 FORMULA:

Duty Cycle =  $T_{on} / (T_{on} + T_{off})$

### Measurement Procedure:

1. Set span = Zero
2. RBW = 8MHz
3. VBW = 8MHz,
4. Detector = Peak

### Duty Cycle:

	Duty Cycle	Duty Fator (dB)
802.11b	1	0
802.11g	1	0
802.11N20	1	0
802.11N40	1	0



## **9. ANTENNA REQUIREMENT**

### **9.1 STANDARD REQUIREMENT**

15.203 requirement: For intentional device, according to 15.203: an intentional radiator shall be designed to ensure that no antenna other than that furnished by the responsible party shall be used with the device.

### **9.2 EUT ANTENNA**

The EUT antenna is Reverse SMA-type antenna, It comply with the standard requirement.



## 10. EUT TEST PHOTO

### Conducted Measurement Photos





### Radiated Measurement Photos



### Radiated Measurement Photos

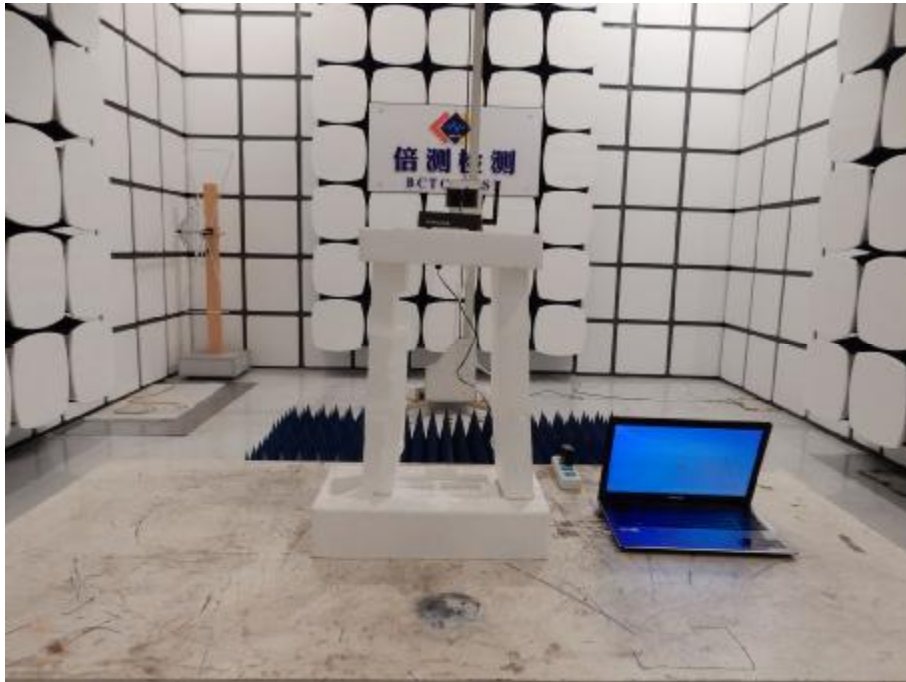

11. EUT PHOTO



\*\*\*\*\* END OF REPORT \*\*\*\*\*