

CHANNEL	TX Channel 138	DETECTOR FUNCTION	Peak (PK)
FREQUENCY RANGE	1GHz ~ 40GHz		Average (AV)

ANTENNA POLARITY & TEST DISTANCE: HORIZONTAL AT 3 M

NO.	FREQ. (MHz)	EMISSION LEVEL (dBuV/m)	LIMIT (dBuV/m)	MARGIN (dB)	ANTENNA HEIGHT (m)	TABLE ANGLE (Degree)	RAW VALUE (dBuV)	CORRECTION FACTOR (dB/m)
1	#5470.00	48.4 PK	74.0	-25.6	1.45 H	96	44.4	4.0
2	#5470.00	36.8 AV	54.0	-17.2	1.45 H	96	32.8	4.0
3	*5690.00	100.5 PK			1.45 H	96	96.3	4.2
4	*5690.00	90.6 AV			1.45 H	96	86.4	4.2
5	#5850.00	60.0 PK	74.0	-14.0	1.45 H	96	55.4	4.6
6	#5850.00	45.5 AV	54.0	-8.5	1.45 H	96	40.9	4.6
7	11380.00	47.8 PK	74.0	-26.2	1.66 H	189	34.1	13.7
8	11380.00	36.0 AV	54.0	-18.0	1.66 H	189	22.3	13.7
9	#17070.00	46.7 PK	74.0	-27.3	1.58 H	212	30.1	16.6
10	#17070.00	35.4 AV	54.0	-18.6	1.58 H	212	18.8	16.6

ANTENNA POLARITY & TEST DISTANCE: VERTICAL AT 3 M

NO.	FREQ. (MHz)	EMISSION LEVEL (dBuV/m)	LIMIT (dBuV/m)	MARGIN (dB)	ANTENNA HEIGHT (m)	TABLE ANGLE (Degree)	RAW VALUE (dBuV)	CORRECTION FACTOR (dB/m)
1	#5470.00	69.8 PK	74.0	-4.2	1.58 V	346	65.8	4.0
2	#5470.00	50.6 AV	54.0	-3.4	1.58 V	346	46.6	4.0
3	*5690.00	105.6 PK			1.58 V	346	101.4	4.2
4	*5690.00	96.9 AV			1.58 V	346	92.7	4.2
5	#5850.00	53.6 PK	74.0	-20.4	1.58 V	346	49.0	4.6
6	#5850.00	41.0 AV	54.0	-13.0	1.58 V	346	36.4	4.6
7	11380.00	48.6 PK	74.0	-25.4	1.53 V	169	34.9	13.7
8	11380.00	37.3 AV	54.0	-16.7	1.53 V	169	23.6	13.7
9	#17070.00	47.3 PK	74.0	-26.7	1.65 V	190	30.7	16.6
10	#17070.00	36.6 AV	54.0	-17.4	1.65 V	190	20.0	16.6

REMARKS:

1. Emission Level(dBuV/m) = Raw Value(dBuV) + Correction Factor(dB/m)
2. Correction Factor(dB/m) = Antenna Factor(dB/m) + Cable Factor(dB) – Pre-Amplifier Factor(dB)
3. The other emission levels were very low against the limit.
4. Margin value = Emission Level – Limit value
5. " * ": Fundamental frequency.
6. " # ": The radiated frequency is out of the restricted band.

Below 1GHz Data:

802.11ac (VHT20)

CHANNEL	TX Channel 140	DETECTOR FUNCTION	Quasi-Peak (QP)
FREQUENCY RANGE	9kHz ~ 1GHz		

ANTENNA POLARITY & TEST DISTANCE: HORIZONTAL AT 3 M

NO.	FREQ. (MHz)	EMISSION LEVEL (dBuV/m)	LIMIT (dBuV/m)	MARGIN (dB)	ANTENNA HEIGHT (m)	TABLE ANGLE (Degree)	RAW VALUE (dBuV)	CORRECTION FACTOR (dB/m)
1	88.39	33.5 QP	43.5	-10.0	1.00 H	360	47.7	-14.2
2	113.86	31.8 QP	43.5	-11.7	3.00 H	263	42.6	-10.8
3	223.98	31.8 QP	46.0	-14.2	1.00 H	57	42.9	-11.1
4	348.94	34.9 QP	46.0	-11.1	1.00 H	295	41.4	-6.5
5	398.26	37.1 QP	46.0	-8.9	3.00 H	175	42.5	-5.4
6	469.00	34.0 QP	46.0	-12.0	3.00 H	127	37.6	-3.6

ANTENNA POLARITY & TEST DISTANCE: VERTICAL AT 3 M

NO.	FREQ. (MHz)	EMISSION LEVEL (dBuV/m)	LIMIT (dBuV/m)	MARGIN (dB)	ANTENNA HEIGHT (m)	TABLE ANGLE (Degree)	RAW VALUE (dBuV)	CORRECTION FACTOR (dB/m)
1	37.93	35.2 QP	40.0	-4.8	1.00 V	100	43.9	-8.7
2	114.73	33.6 QP	43.5	-9.9	1.00 V	33	44.3	-10.7
3	224.34	29.7 QP	46.0	-16.3	1.00 V	212	40.7	-11.0
4	343.65	40.3 QP	46.0	-5.7	2.00 V	360	46.8	-6.5
5	384.92	39.8 QP	46.0	-6.2	1.00 V	95	45.5	-5.7
6	479.35	35.9 QP	46.0	-10.1	1.00 V	57	39.4	-3.5

REMARKS:

1. Emission Level(dBuV/m) = Raw Value(dBuV) + Correction Factor(dB/m)
2. Correction Factor(dB/m) = Antenna Factor(dB/m) + Cable Factor(dB) – Pre-Amplifier Factor(dB)
3. The other emission levels were very low against the limit.
4. Margin value = Emission Level – Limit value

4.1.10 Test Results (Mode 4)

PIFA Antenna
Above 1GHz Data:
802.11a

CHANNEL	TX Channel 52	DETECTOR FUNCTION	Peak (PK)
FREQUENCY RANGE	1GHz ~ 40GHz		Average (AV)

ANTENNA POLARITY & TEST DISTANCE: HORIZONTAL AT 3 M

NO.	FREQ. (MHz)	EMISSION LEVEL (dBuV/m)	LIMIT (dBuV/m)	MARGIN (dB)	ANTENNA HEIGHT (m)	TABLE ANGLE (Degree)	RAW VALUE (dBuV)	CORRECTION FACTOR (dB/m)
1	5150.00	52.7 PK	74.0	-21.3	1.87 H	311	49.0	3.7
2	5150.00	40.7 AV	54.0	-13.3	1.87 H	311	37.0	3.7
3	*5260.00	114.3 PK			1.87 H	311	110.3	4.0
4	*5260.00	104.3 AV			1.87 H	311	100.3	4.0
5	#10520.00	46.3 PK	74.0	-27.7	1.58 H	141	33.1	13.2
6	#10520.00	34.0 AV	54.0	-20.0	1.58 H	141	20.8	13.2
7	15780.00	56.2 PK	74.0	-17.8	3.09 H	308	42.6	13.6
8	15780.00	43.8 AV	54.0	-10.2	3.09 H	308	30.2	13.6

ANTENNA POLARITY & TEST DISTANCE: VERTICAL AT 3 M

NO.	FREQ. (MHz)	EMISSION LEVEL (dBuV/m)	LIMIT (dBuV/m)	MARGIN (dB)	ANTENNA HEIGHT (m)	TABLE ANGLE (Degree)	RAW VALUE (dBuV)	CORRECTION FACTOR (dB/m)
1	5150.00	52.9 PK	74.0	-21.1	1.34 V	350	49.2	3.7
2	5150.00	41.5 AV	54.0	-12.5	1.34 V	350	37.8	3.7
3	*5260.00	116.2 PK			1.34 V	350	112.2	4.0
4	*5260.00	105.9 AV			1.34 V	350	101.9	4.0
5	#10520.00	48.6 PK	74.0	-25.4	1.99 V	25	35.4	13.2
6	#10520.00	35.8 AV	54.0	-18.2	1.99 V	25	22.6	13.2
7	15780.00	56.3 PK	74.0	-17.7	2.27 V	330	42.7	13.6
8	15780.00	44.0 AV	54.0	-10.0	2.27 V	330	30.4	13.6

REMARKS:

1. Emission Level(dBuV/m) = Raw Value(dBuV) + Correction Factor(dB/m)
2. Correction Factor(dB/m) = Antenna Factor(dB/m) + Cable Factor(dB) – Pre-Amplifier Factor(dB)
3. The other emission levels were very low against the limit.
4. Margin value = Emission Level – Limit value
5. " * ": Fundamental frequency.
6. " # ": The radiated frequency is out of the restricted band.

CHANNEL	TX Channel 60	DETECTOR FUNCTION	Peak (PK)
FREQUENCY RANGE	1GHz ~ 40GHz		Average (AV)

ANTENNA POLARITY & TEST DISTANCE: HORIZONTAL AT 3 M

NO.	FREQ. (MHz)	EMISSION LEVEL (dBuV/m)	LIMIT (dBuV/m)	MARGIN (dB)	ANTENNA HEIGHT (m)	TABLE ANGLE (Degree)	RAW VALUE (dBuV)	CORRECTION FACTOR (dB/m)
1	*5300.00	114.1 PK			1.85 H	310	110.0	4.1
2	*5300.00	104.0 AV			1.85 H	310	99.9	4.1
3	10600.00	46.3 PK	74.0	-27.7	1.62 H	148	32.8	13.5
4	10600.00	34.2 AV	54.0	-19.8	1.62 H	148	20.7	13.5
5	15900.00	56.6 PK	74.0	-17.4	3.06 H	293	43.7	12.9
6	15900.00	44.0 AV	54.0	-10.0	3.06 H	293	31.1	12.9

ANTENNA POLARITY & TEST DISTANCE: VERTICAL AT 3 M

NO.	FREQ. (MHz)	EMISSION LEVEL (dBuV/m)	LIMIT (dBuV/m)	MARGIN (dB)	ANTENNA HEIGHT (m)	TABLE ANGLE (Degree)	RAW VALUE (dBuV)	CORRECTION FACTOR (dB/m)
1	*5300.00	115.8 PK			1.45 V	349	111.7	4.1
2	*5300.00	106.1 AV			1.45 V	349	102.0	4.1
3	10600.00	48.5 PK	74.0	-25.5	1.97 V	27	35.0	13.5
4	10600.00	35.9 AV	54.0	-18.1	1.97 V	27	22.4	13.5
5	15900.00	56.7 PK	74.0	-17.3	2.31 V	337	43.8	12.9
6	15900.00	44.4 AV	54.0	-9.6	2.31 V	337	31.5	12.9

REMARKS:

1. Emission Level(dBuV/m) = Raw Value(dBuV) + Correction Factor(dB/m)
2. Correction Factor(dB/m) = Antenna Factor(dB/m) + Cable Factor(dB) – Pre-Amplifier Factor(dB)
3. The other emission levels were very low against the limit.
4. Margin value = Emission Level – Limit value
5. " * ": Fundamental frequency.

CHANNEL	TX Channel 64	DETECTOR FUNCTION	Peak (PK)
FREQUENCY RANGE	1GHz ~ 40GHz		Average (AV)

ANTENNA POLARITY & TEST DISTANCE: HORIZONTAL AT 3 M

NO.	FREQ. (MHz)	EMISSION LEVEL (dBuV/m)	LIMIT (dBuV/m)	MARGIN (dB)	ANTENNA HEIGHT (m)	TABLE ANGLE (Degree)	RAW VALUE (dBuV)	CORRECTION FACTOR (dB/m)
1	*5320.00	111.4 PK			1.86 H	315	107.3	4.1
2	*5320.00	101.5 AV			1.86 H	315	97.4	4.1
3	5350.00	68.4 PK	74.0	-5.6	1.86 H	315	64.3	4.1
4	5350.00	53.0 AV	54.0	-1.0	1.86 H	315	48.9	4.1
5	10640.00	46.0 PK	74.0	-28.0	1.62 H	157	32.5	13.5
6	10640.00	33.9 AV	54.0	-20.1	1.62 H	157	20.4	13.5
7	15960.00	55.8 PK	74.0	-18.2	3.09 H	319	42.9	12.9
8	15960.00	43.3 AV	54.0	-10.7	3.09 H	319	30.4	12.9

ANTENNA POLARITY & TEST DISTANCE: VERTICAL AT 3 M

NO.	FREQ. (MHz)	EMISSION LEVEL (dBuV/m)	LIMIT (dBuV/m)	MARGIN (dB)	ANTENNA HEIGHT (m)	TABLE ANGLE (Degree)	RAW VALUE (dBuV)	CORRECTION FACTOR (dB/m)
1	*5320.00	113.3 PK			1.45 V	334	109.2	4.1
2	*5320.00	103.1 AV			1.45 V	334	99.0	4.1
3	5350.00	68.6 PK	74.0	-5.4	1.45 V	334	64.5	4.1
4	5350.00	53.8 AV	54.0	-0.2	1.45 V	334	49.7	4.1
5	10640.00	48.2 PK	74.0	-25.8	1.97 V	17	34.7	13.5
6	10640.00	35.7 AV	54.0	-18.3	1.97 V	17	22.2	13.5
7	15960.00	56.7 PK	74.0	-17.3	2.26 V	326	43.8	12.9
8	15960.00	44.4 AV	54.0	-9.6	2.26 V	326	31.5	12.9

REMARKS:

1. Emission Level(dBuV/m) = Raw Value(dBuV) + Correction Factor(dB/m)
2. Correction Factor(dB/m) = Antenna Factor(dB/m) + Cable Factor(dB) – Pre-Amplifier Factor(dB)
3. The other emission levels were very low against the limit.
4. Margin value = Emission Level – Limit value
5. " * ": Fundamental frequency.

CHANNEL	TX Channel 100	DETECTOR FUNCTION	Peak (PK)
FREQUENCY RANGE	1GHz ~ 40GHz		Average (AV)

ANTENNA POLARITY & TEST DISTANCE: HORIZONTAL AT 3 M

NO.	FREQ. (MHz)	EMISSION LEVEL (dBuV/m)	LIMIT (dBuV/m)	MARGIN (dB)	ANTENNA HEIGHT (m)	TABLE ANGLE (Degree)	RAW VALUE (dBuV)	CORRECTION FACTOR (dB/m)
1	#5470.00	72.8 PK	74.0	-1.2	1.85 H	360	68.6	4.2
2	#5470.00	53.9 AV	54.0	-0.1	1.85 H	360	49.7	4.2
3	*5500.00	112.6 PK			1.85 H	360	108.4	4.2
4	*5500.00	101.6 AV			1.85 H	360	97.4	4.2
5	11000.00	48.1 PK	74.0	-25.9	1.98 H	22	34.0	14.1
6	11000.00	35.3 AV	54.0	-18.7	1.98 H	22	21.2	14.1
7	#16500.00	56.8 PK	74.0	-17.2	2.26 H	338	42.3	14.5
8	#16500.00	44.3 AV	54.0	-9.7	2.26 H	338	29.8	14.5

ANTENNA POLARITY & TEST DISTANCE: VERTICAL AT 3 M

NO.	FREQ. (MHz)	EMISSION LEVEL (dBuV/m)	LIMIT (dBuV/m)	MARGIN (dB)	ANTENNA HEIGHT (m)	TABLE ANGLE (Degree)	RAW VALUE (dBuV)	CORRECTION FACTOR (dB/m)
1	#5470.00	69.0 PK	74.0	-5.0	3.55 V	309	64.8	4.2
2	#5470.00	52.2 AV	54.0	-1.8	3.55 V	309	48.0	4.2
3	*5500.00	111.2 PK			3.55 V	309	107.0	4.2
4	*5500.00	99.8 AV			3.55 V	309	95.6	4.2
5	11000.00	46.3 PK	74.0	-27.7	1.69 V	136	32.2	14.1
6	11000.00	33.9 AV	54.0	-20.1	1.69 V	136	19.8	14.1
7	#16500.00	56.0 PK	74.0	-18.0	3.13 V	312	41.5	14.5
8	#16500.00	43.5 AV	54.0	-10.5	3.13 V	312	29.0	14.5

REMARKS:

1. Emission Level(dBuV/m) = Raw Value(dBuV) + Correction Factor(dB/m)
2. Correction Factor(dB/m) = Antenna Factor(dB/m) + Cable Factor(dB) – Pre-Amplifier Factor(dB)
3. The other emission levels were very low against the limit.
4. Margin value = Emission Level – Limit value
5. " * ": Fundamental frequency.
6. " # ": The radiated frequency is out of the restricted band.

CHANNEL	TX Channel 116	DETECTOR FUNCTION	Peak (PK)
FREQUENCY RANGE	1GHz ~ 40GHz		Average (AV)

ANTENNA POLARITY & TEST DISTANCE: HORIZONTAL AT 3 M

NO.	FREQ. (MHz)	EMISSION LEVEL (dBuV/m)	LIMIT (dBuV/m)	MARGIN (dB)	ANTENNA HEIGHT (m)	TABLE ANGLE (Degree)	RAW VALUE (dBuV)	CORRECTION FACTOR (dB/m)
1	*5580.00	113.3 PK			1.85 H	360	109.1	4.2
2	*5580.00	103.8 AV			1.85 H	360	99.6	4.2
3	11160.00	48.7 PK	74.0	-25.3	1.94 H	35	35.0	13.7
4	11160.00	35.6 AV	54.0	-18.4	1.94 H	35	21.9	13.7
5	#16740.00	56.4 PK	74.0	-17.6	2.31 H	353	40.7	15.7
6	#16740.00	44.1 AV	54.0	-9.9	2.31 H	353	28.4	15.7

ANTENNA POLARITY & TEST DISTANCE: VERTICAL AT 3 M

NO.	FREQ. (MHz)	EMISSION LEVEL (dBuV/m)	LIMIT (dBuV/m)	MARGIN (dB)	ANTENNA HEIGHT (m)	TABLE ANGLE (Degree)	RAW VALUE (dBuV)	CORRECTION FACTOR (dB/m)
1	*5580.00	111.9 PK			3.52 V	321	107.7	4.2
2	*5580.00	102.0 AV			3.52 V	321	97.8	4.2
3	11160.00	45.8 PK	74.0	-28.2	1.63 V	130	32.1	13.7
4	11160.00	33.6 AV	54.0	-20.4	1.63 V	130	19.9	13.7
5	#16740.00	56.4 PK	74.0	-17.6	3.08 V	321	40.7	15.7
6	#16740.00	43.7 AV	54.0	-10.3	3.08 V	321	28.0	15.7

REMARKS:

1. Emission Level(dBuV/m) = Raw Value(dBuV) + Correction Factor(dB/m)
2. Correction Factor(dB/m) = Antenna Factor(dB/m) + Cable Factor(dB) – Pre-Amplifier Factor(dB)
3. The other emission levels were very low against the limit.
4. Margin value = Emission Level – Limit value
5. " * ": Fundamental frequency.
6. " # ": The radiated frequency is out of the restricted band.

CHANNEL	TX Channel 140	DETECTOR FUNCTION	Peak (PK)
FREQUENCY RANGE	1GHz ~ 40GHz		Average (AV)

ANTENNA POLARITY & TEST DISTANCE: HORIZONTAL AT 3 M

NO.	FREQ. (MHz)	EMISSION LEVEL (dBuV/m)	LIMIT (dBuV/m)	MARGIN (dB)	ANTENNA HEIGHT (m)	TABLE ANGLE (Degree)	RAW VALUE (dBuV)	CORRECTION FACTOR (dB/m)
1	*5700.00	110.9 PK			1.82 H	360	106.4	4.5
2	*5700.00	100.2 AV			1.82 H	360	95.7	4.5
3	#5725.00	68.3 PK	74.0	-5.7	1.82 H	360	63.9	4.4
4	#5725.00	53.8 AV	54.0	-0.2	1.82 H	360	49.4	4.4
5	11400.00	49.0 PK	74.0	-25.0	1.98 H	48	35.4	13.6
6	11400.00	36.0 AV	54.0	-18.0	1.98 H	48	22.4	13.6
7	#17100.00	56.1 PK	74.0	-17.9	2.32 H	347	38.7	17.4
8	#17100.00	44.0 AV	54.0	-10.0	2.32 H	347	26.6	17.4

ANTENNA POLARITY & TEST DISTANCE: VERTICAL AT 3 M

NO.	FREQ. (MHz)	EMISSION LEVEL (dBuV/m)	LIMIT (dBuV/m)	MARGIN (dB)	ANTENNA HEIGHT (m)	TABLE ANGLE (Degree)	RAW VALUE (dBuV)	CORRECTION FACTOR (dB/m)
1	*5700.00	109.5 PK			3.55 V	315	105.0	4.5
2	*5700.00	98.4 AV			3.55 V	315	93.9	4.5
3	#5725.00	64.5 PK	74.0	-9.5	3.55 V	315	60.1	4.4
4	#5725.00	52.1 AV	54.0	-1.9	3.55 V	315	47.7	4.4
5	11400.00	46.6 PK	74.0	-27.4	1.72 V	150	33.0	13.6
6	11400.00	34.0 AV	54.0	-20.0	1.72 V	150	20.4	13.6
7	#17100.00	55.5 PK	74.0	-18.5	3.13 V	299	38.1	17.4
8	#17100.00	43.2 AV	54.0	-10.8	3.13 V	299	25.8	17.4

REMARKS:

1. Emission Level(dBuV/m) = Raw Value(dBuV) + Correction Factor(dB/m)
2. Correction Factor(dB/m) = Antenna Factor(dB/m) + Cable Factor(dB) – Pre-Amplifier Factor(dB)
3. The other emission levels were very low against the limit.
4. Margin value = Emission Level – Limit value
5. " * ": Fundamental frequency.
6. " # ": The radiated frequency is out of the restricted band.

CHANNEL	TX Channel 144	DETECTOR FUNCTION	Peak (PK)
FREQUENCY RANGE	1GHz ~ 40GHz		Average (AV)

ANTENNA POLARITY & TEST DISTANCE: HORIZONTAL AT 3 M

NO.	FREQ. (MHz)	EMISSION LEVEL (dBuV/m)	LIMIT (dBuV/m)	MARGIN (dB)	ANTENNA HEIGHT (m)	TABLE ANGLE (Degree)	RAW VALUE (dBuV)	CORRECTION FACTOR (dB/m)
1	#5470.00	57.5 PK	74.0	-16.5	1.78 H	360	53.5	4.0
2	#5470.00	48.3 AV	54.0	-5.7	1.78 H	360	44.3	4.0
3	*5720.00	110.8 PK			1.78 H	360	106.6	4.2
4	*5720.00	100.2 AV			1.78 H	360	96.0	4.2
5	#5850.00	68.5 PK	74.0	-5.5	1.78 H	360	63.9	4.6
6	#5850.00	53.7 AV	54.0	-0.3	1.78 H	360	49.1	4.6
7	11440.00	49.6 PK	74.0	-24.4	1.97 H	64	35.8	13.8
8	11440.00	36.4 AV	54.0	-17.6	1.97 H	64	22.6	13.8
9	#17160.00	55.4 PK	74.0	-18.6	2.37 H	356	39.0	16.4
10	#17160.00	43.6 AV	54.0	-10.4	2.37 H	356	27.2	16.4

ANTENNA POLARITY & TEST DISTANCE: VERTICAL AT 3 M

NO.	FREQ. (MHz)	EMISSION LEVEL (dBuV/m)	LIMIT (dBuV/m)	MARGIN (dB)	ANTENNA HEIGHT (m)	TABLE ANGLE (Degree)	RAW VALUE (dBuV)	CORRECTION FACTOR (dB/m)
1	#5470.00	53.9 PK	74.0	-20.1	3.61 V	311	49.9	4.0
2	#5470.00	47.2 AV	54.0	-6.8	3.61 V	311	43.2	4.0
3	*5720.00	109.1 PK			3.61 V	311	104.9	4.2
4	*5720.00	98.0 AV			3.61 V	311	93.8	4.2
5	#5850.00	64.0 PK	74.0	-10.0	3.61 V	311	59.4	4.6
6	#5850.00	51.7 AV	54.0	-2.3	3.61 V	311	47.1	4.6
7	11440.00	46.1 PK	74.0	-27.9	1.77 V	137	32.3	13.8
8	11440.00	33.8 AV	54.0	-20.2	1.77 V	137	20.0	13.8
9	#17160.00	55.3 PK	74.0	-18.7	3.10 V	308	38.9	16.4
10	#17160.00	42.8 AV	54.0	-11.2	3.10 V	308	26.4	16.4

REMARKS:

1. Emission Level(dBuV/m) = Raw Value(dBuV) + Correction Factor(dB/m)
2. Correction Factor(dB/m) = Antenna Factor(dB/m) + Cable Factor(dB) – Pre-Amplifier Factor(dB)
3. The other emission levels were very low against the limit.
4. Margin value = Emission Level – Limit value
5. " * ": Fundamental frequency.
6. " # ": The radiated frequency is out of the restricted band.

802.11ac (VHT20)

CHANNEL	TX Channel 52	DETECTOR FUNCTION	Peak (PK)
FREQUENCY RANGE	1GHz ~ 40GHz		Average (AV)

ANTENNA POLARITY & TEST DISTANCE: HORIZONTAL AT 3 M

NO.	FREQ. (MHz)	EMISSION LEVEL (dBuV/m)	LIMIT (dBuV/m)	MARGIN (dB)	ANTENNA HEIGHT (m)	TABLE ANGLE (Degree)	RAW VALUE (dBuV)	CORRECTION FACTOR (dB/m)
1	5150.00	52.9 PK	74.0	-21.1	1.80 H	314	49.2	3.7
2	5150.00	40.8 AV	54.0	-13.2	1.80 H	314	37.1	3.7
3	*5260.00	114.7 PK			1.80 H	314	110.7	4.0
4	*5260.00	104.7 AV			1.80 H	314	100.7	4.0
5	#10520.00	46.1 PK	74.0	-27.9	1.54 H	129	32.9	13.2
6	#10520.00	33.9 AV	54.0	-20.1	1.54 H	129	20.7	13.2
7	15780.00	56.2 PK	74.0	-17.8	3.12 H	322	42.6	13.6
8	15780.00	43.6 AV	54.0	-10.4	3.12 H	322	30.0	13.6

ANTENNA POLARITY & TEST DISTANCE: VERTICAL AT 3 M

NO.	FREQ. (MHz)	EMISSION LEVEL (dBuV/m)	LIMIT (dBuV/m)	MARGIN (dB)	ANTENNA HEIGHT (m)	TABLE ANGLE (Degree)	RAW VALUE (dBuV)	CORRECTION FACTOR (dB/m)
1	5150.00	53.4 PK	74.0	-20.6	1.42 V	352	49.7	3.7
2	5150.00	42.1 AV	54.0	-11.9	1.42 V	352	38.4	3.7
3	*5260.00	115.9 PK			1.42 V	352	111.9	4.0
4	*5260.00	105.7 AV			1.42 V	352	101.7	4.0
5	#10520.00	48.5 PK	74.0	-25.5	2.02 V	41	35.3	13.2
6	#10520.00	35.6 AV	54.0	-18.4	2.02 V	41	22.4	13.2
7	15780.00	56.3 PK	74.0	-17.7	2.24 V	316	42.7	13.6
8	15780.00	44.0 AV	54.0	-10.0	2.24 V	316	30.4	13.6

REMARKS:

- Emission Level(dBuV/m) = Raw Value(dBuV) + Correction Factor(dB/m)
- Correction Factor(dB/m) = Antenna Factor(dB/m) + Cable Factor(dB) – Pre-Amplifier Factor(dB)
- The other emission levels were very low against the limit.
- Margin value = Emission Level – Limit value
- " * ": Fundamental frequency.
- " # ": The radiated frequency is out of the restricted band.

CHANNEL	TX Channel 60	DETECTOR FUNCTION	Peak (PK)
FREQUENCY RANGE	1GHz ~ 40GHz		Average (AV)

ANTENNA POLARITY & TEST DISTANCE: HORIZONTAL AT 3 M

NO.	FREQ. (MHz)	EMISSION LEVEL (dBuV/m)	LIMIT (dBuV/m)	MARGIN (dB)	ANTENNA HEIGHT (m)	TABLE ANGLE (Degree)	RAW VALUE (dBuV)	CORRECTION FACTOR (dB/m)
1	*5300.00	114.8 PK			1.78 H	305	110.7	4.1
2	*5300.00	104.8 AV			1.78 H	305	100.7	4.1
3	10600.00	46.0 PK	74.0	-28.0	1.53 H	154	32.5	13.5
4	10600.00	34.0 AV	54.0	-20.0	1.53 H	154	20.5	13.5
5	15900.00	56.5 PK	74.0	-17.5	3.11 H	318	43.6	12.9
6	15900.00	44.0 AV	54.0	-10.0	3.11 H	318	31.1	12.9

ANTENNA POLARITY & TEST DISTANCE: VERTICAL AT 3 M

NO.	FREQ. (MHz)	EMISSION LEVEL (dBuV/m)	LIMIT (dBuV/m)	MARGIN (dB)	ANTENNA HEIGHT (m)	TABLE ANGLE (Degree)	RAW VALUE (dBuV)	CORRECTION FACTOR (dB/m)
1	*5300.00	116.1 PK			1.31 V	336	112.0	4.1
2	*5300.00	105.7 AV			1.31 V	336	101.6	4.1
3	10600.00	48.8 PK	74.0	-25.2	1.96 V	38	35.3	13.5
4	10600.00	36.1 AV	54.0	-17.9	1.96 V	38	22.6	13.5
5	15900.00	56.5 PK	74.0	-17.5	2.28 V	336	43.6	12.9
6	15900.00	44.1 AV	54.0	-9.9	2.28 V	336	31.2	12.9

REMARKS:

1. Emission Level(dBuV/m) = Raw Value(dBuV) + Correction Factor(dB/m)
2. Correction Factor(dB/m) = Antenna Factor(dB/m) + Cable Factor(dB) – Pre-Amplifier Factor(dB)
3. The other emission levels were very low against the limit.
4. Margin value = Emission Level – Limit value
5. " * ": Fundamental frequency.

CHANNEL	TX Channel 64	DETECTOR FUNCTION	Peak (PK)
FREQUENCY RANGE	1GHz ~ 40GHz		Average (AV)

ANTENNA POLARITY & TEST DISTANCE: HORIZONTAL AT 3 M

NO.	FREQ. (MHz)	EMISSION LEVEL (dBuV/m)	LIMIT (dBuV/m)	MARGIN (dB)	ANTENNA HEIGHT (m)	TABLE ANGLE (Degree)	RAW VALUE (dBuV)	CORRECTION FACTOR (dB/m)
1	*5320.00	111.6 PK			1.79 H	307	107.5	4.1
2	*5320.00	101.2 AV			1.79 H	307	97.1	4.1
3	5350.00	71.7 PK	74.0	-2.3	1.79 H	307	67.6	4.1
4	5350.00	52.5 AV	54.0	-1.5	1.79 H	307	48.4	4.1
5	10640.00	46.4 PK	74.0	-27.6	1.59 H	136	32.9	13.5
6	10640.00	33.8 AV	54.0	-20.2	1.59 H	136	20.3	13.5
7	15960.00	56.1 PK	74.0	-17.9	3.13 H	305	43.2	12.9
8	15960.00	43.7 AV	54.0	-10.3	3.13 H	305	30.8	12.9

ANTENNA POLARITY & TEST DISTANCE: VERTICAL AT 3 M

NO.	FREQ. (MHz)	EMISSION LEVEL (dBuV/m)	LIMIT (dBuV/m)	MARGIN (dB)	ANTENNA HEIGHT (m)	TABLE ANGLE (Degree)	RAW VALUE (dBuV)	CORRECTION FACTOR (dB/m)
1	*5320.00	112.8 PK			1.43 V	333	108.7	4.1
2	*5320.00	102.2 AV			1.43 V	333	98.1	4.1
3	5350.00	72.2 PK	74.0	-1.8	1.43 V	333	68.1	4.1
4	5350.00	53.7 AV	54.0	-0.3	1.43 V	333	49.6	4.1
5	10640.00	48.5 PK	74.0	-25.5	1.96 V	35	35.0	13.5
6	10640.00	35.9 AV	54.0	-18.1	1.96 V	35	22.4	13.5
7	15960.00	56.6 PK	74.0	-17.4	2.24 V	320	43.7	12.9
8	15960.00	44.3 AV	54.0	-9.7	2.24 V	320	31.4	12.9

REMARKS:

1. Emission Level(dBuV/m) = Raw Value(dBuV) + Correction Factor(dB/m)
2. Correction Factor(dB/m) = Antenna Factor(dB/m) + Cable Factor(dB) – Pre-Amplifier Factor(dB)
3. The other emission levels were very low against the limit.
4. Margin value = Emission Level – Limit value
5. " * ": Fundamental frequency.

CHANNEL	TX Channel 100	DETECTOR FUNCTION	Peak (PK)
FREQUENCY RANGE	1GHz ~ 40GHz		Average (AV)

ANTENNA POLARITY & TEST DISTANCE: HORIZONTAL AT 3 M

NO.	FREQ. (MHz)	EMISSION LEVEL (dBuV/m)	LIMIT (dBuV/m)	MARGIN (dB)	ANTENNA HEIGHT (m)	TABLE ANGLE (Degree)	RAW VALUE (dBuV)	CORRECTION FACTOR (dB/m)
1	#5470.00	71.3 PK	74.0	-2.7	1.83 H	360	67.1	4.2
2	#5470.00	53.9 AV	54.0	-0.1	1.83 H	360	49.7	4.2
3	*5500.00	112.8 PK			1.83 H	360	108.6	4.2
4	*5500.00	102.0 AV			1.83 H	360	97.8	4.2
5	11000.00	48.8 PK	74.0	-25.2	1.92 H	26	34.7	14.1
6	11000.00	35.7 AV	54.0	-18.3	1.92 H	26	21.6	14.1
7	#16500.00	55.6 PK	74.0	-18.4	2.31 H	344	41.1	14.5
8	#16500.00	43.6 AV	54.0	-10.4	2.31 H	344	29.1	14.5

ANTENNA POLARITY & TEST DISTANCE: VERTICAL AT 3 M

NO.	FREQ. (MHz)	EMISSION LEVEL (dBuV/m)	LIMIT (dBuV/m)	MARGIN (dB)	ANTENNA HEIGHT (m)	TABLE ANGLE (Degree)	RAW VALUE (dBuV)	CORRECTION FACTOR (dB/m)
1	#5470.00	67.5 PK	74.0	-6.5	3.50 V	308	63.3	4.2
2	#5470.00	52.1 AV	54.0	-1.9	3.50 V	308	47.9	4.2
3	*5500.00	111.4 PK			3.50 V	308	107.2	4.2
4	*5500.00	100.2 AV			3.50 V	308	96.0	4.2
5	11000.00	45.9 PK	74.0	-28.1	1.72 V	133	31.8	14.1
6	11000.00	33.7 AV	54.0	-20.3	1.72 V	133	19.6	14.1
7	#16500.00	55.9 PK	74.0	-18.1	3.11 V	313	41.4	14.5
8	#16500.00	43.6 AV	54.0	-10.4	3.11 V	313	29.1	14.5

REMARKS:

1. Emission Level(dBuV/m) = Raw Value(dBuV) + Correction Factor(dB/m)
2. Correction Factor(dB/m) = Antenna Factor(dB/m) + Cable Factor(dB) – Pre-Amplifier Factor(dB)
3. The other emission levels were very low against the limit.
4. Margin value = Emission Level – Limit value
5. " * ": Fundamental frequency.
6. " # ": The radiated frequency is out of the restricted band.

CHANNEL	TX Channel 116	DETECTOR FUNCTION	Peak (PK)
FREQUENCY RANGE	1GHz ~ 40GHz		Average (AV)

ANTENNA POLARITY & TEST DISTANCE: HORIZONTAL AT 3 M

NO.	FREQ. (MHz)	EMISSION LEVEL (dBuV/m)	LIMIT (dBuV/m)	MARGIN (dB)	ANTENNA HEIGHT (m)	TABLE ANGLE (Degree)	RAW VALUE (dBuV)	CORRECTION FACTOR (dB/m)
1	*5580.00	115.9 PK			1.84 H	360	111.7	4.2
2	*5580.00	105.3 AV			1.84 H	360	101.1	4.2
3	#5820.00	57.7 PK	74.0	-16.3	1.84 H	360	53.3	4.4
4	#5820.00	48.6 AV	54.0	-5.4	1.84 H	360	44.2	4.4
5	11160.00	48.7 PK	74.0	-25.3	1.93 H	22	35.0	13.7
6	11160.00	35.7 AV	54.0	-18.3	1.93 H	22	22.0	13.7
7	#16740.00	56.4 PK	74.0	-17.6	2.34 H	357	40.7	15.7
8	#16740.00	44.1 AV	54.0	-9.9	2.34 H	357	28.4	15.7

ANTENNA POLARITY & TEST DISTANCE: VERTICAL AT 3 M

NO.	FREQ. (MHz)	EMISSION LEVEL (dBuV/m)	LIMIT (dBuV/m)	MARGIN (dB)	ANTENNA HEIGHT (m)	TABLE ANGLE (Degree)	RAW VALUE (dBuV)	CORRECTION FACTOR (dB/m)
1	*5580.00	114.5 PK			3.56 V	314	110.3	4.2
2	*5580.00	103.5 AV			3.56 V	314	99.3	4.2
3	#5820.00	53.9 PK	74.0	-20.1	3.56 V	314	49.5	4.4
4	#5820.00	46.9 AV	54.0	-7.1	3.56 V	314	42.5	4.4
5	11160.00	46.5 PK	74.0	-27.5	1.69 V	122	32.8	13.7
6	11160.00	34.2 AV	54.0	-19.8	1.69 V	122	20.5	13.7
7	#16740.00	55.7 PK	74.0	-18.3	3.07 V	297	40.0	15.7
8	#16740.00	43.4 AV	54.0	-10.6	3.07 V	297	27.7	15.7

REMARKS:

1. Emission Level(dBuV/m) = Raw Value(dBuV) + Correction Factor(dB/m)
2. Correction Factor(dB/m) = Antenna Factor(dB/m) + Cable Factor(dB) – Pre-Amplifier Factor(dB)
3. The other emission levels were very low against the limit.
4. Margin value = Emission Level – Limit value
5. " * ": Fundamental frequency.
6. " # ": The radiated frequency is out of the restricted band.

CHANNEL	TX Channel 140	DETECTOR FUNCTION	Peak (PK)
FREQUENCY RANGE	1GHz ~ 40GHz		Average (AV)

ANTENNA POLARITY & TEST DISTANCE: HORIZONTAL AT 3 M

NO.	FREQ. (MHz)	EMISSION LEVEL (dBuV/m)	LIMIT (dBuV/m)	MARGIN (dB)	ANTENNA HEIGHT (m)	TABLE ANGLE (Degree)	RAW VALUE (dBuV)	CORRECTION FACTOR (dB/m)
1	*5700.00	111.1 PK			1.71 H	352	106.6	4.5
2	*5700.00	100.2 AV			1.71 H	352	95.7	4.5
3	#5725.00	68.5 PK	74.0	-5.5	1.71 H	352	64.1	4.4
4	#5725.00	53.9 AV	54.0	-0.1	1.71 H	352	49.5	4.4
5	11400.00	48.3 PK	74.0	-25.7	1.89 H	34	34.7	13.6
6	11400.00	35.3 AV	54.0	-18.7	1.89 H	34	21.7	13.6
7	#17100.00	56.8 PK	74.0	-17.2	2.35 H	341	39.4	17.4
8	#17100.00	44.3 AV	54.0	-9.7	2.35 H	341	26.9	17.4

ANTENNA POLARITY & TEST DISTANCE: VERTICAL AT 3 M

NO.	FREQ. (MHz)	EMISSION LEVEL (dBuV/m)	LIMIT (dBuV/m)	MARGIN (dB)	ANTENNA HEIGHT (m)	TABLE ANGLE (Degree)	RAW VALUE (dBuV)	CORRECTION FACTOR (dB/m)
1	*5700.00	109.7 PK			3.50 V	330	105.2	4.5
2	*5700.00	98.4 AV			3.50 V	330	93.9	4.5
3	#5725.00	64.7 PK	74.0	-9.3	3.50 V	330	60.3	4.4
4	#5725.00	52.2 AV	54.0	-1.8	3.50 V	330	47.8	4.4
5	11400.00	46.2 PK	74.0	-27.8	1.67 V	121	32.6	13.6
6	11400.00	33.7 AV	54.0	-20.3	1.67 V	121	20.1	13.6
7	#17100.00	56.1 PK	74.0	-17.9	3.09 V	317	38.7	17.4
8	#17100.00	43.8 AV	54.0	-10.2	3.09 V	317	26.4	17.4

REMARKS:

1. Emission Level(dBuV/m) = Raw Value(dBuV) + Correction Factor(dB/m)
2. Correction Factor(dB/m) = Antenna Factor(dB/m) + Cable Factor(dB) – Pre-Amplifier Factor(dB)
3. The other emission levels were very low against the limit.
4. Margin value = Emission Level – Limit value
5. " * ": Fundamental frequency.
6. " # ": The radiated frequency is out of the restricted band.

CHANNEL	TX Channel 144	DETECTOR FUNCTION	Peak (PK)
FREQUENCY RANGE	1GHz ~ 40GHz		Average (AV)

ANTENNA POLARITY & TEST DISTANCE: HORIZONTAL AT 3 M

NO.	FREQ. (MHz)	EMISSION LEVEL (dBuV/m)	LIMIT (dBuV/m)	MARGIN (dB)	ANTENNA HEIGHT (m)	TABLE ANGLE (Degree)	RAW VALUE (dBuV)	CORRECTION FACTOR (dB/m)
1	#5470.00	51.4 PK	74.0	-22.6	1.67 H	346	47.4	4.0
2	#5470.00	40.4 AV	54.0	-13.6	1.67 H	346	36.4	4.0
3	*5720.00	111.6 PK			1.67 H	346	107.4	4.2
4	*5720.00	100.5 AV			1.67 H	346	96.3	4.2
5	#5850.00	68.8 PK	74.0	-5.2	1.67 H	346	64.2	4.6
6	#5850.00	53.8 AV	54.0	-0.2	1.67 H	346	49.2	4.6
7	11440.00	48.1 PK	74.0	-25.9	1.93 H	29	34.3	13.8
8	11440.00	35.0 AV	54.0	-19.0	1.93 H	29	21.2	13.8
9	#17160.00	57.3 PK	74.0	-16.7	2.37 H	349	40.9	16.4
10	#17160.00	44.6 AV	54.0	-9.4	2.37 H	349	28.2	16.4

ANTENNA POLARITY & TEST DISTANCE: VERTICAL AT 3 M

NO.	FREQ. (MHz)	EMISSION LEVEL (dBuV/m)	LIMIT (dBuV/m)	MARGIN (dB)	ANTENNA HEIGHT (m)	TABLE ANGLE (Degree)	RAW VALUE (dBuV)	CORRECTION FACTOR (dB/m)
1	#5470.00	47.5 PK	74.0	-26.5	3.53 V	345	43.5	4.0
2	#5470.00	38.5 AV	54.0	-15.5	3.53 V	345	34.5	4.0
3	*5720.00	109.8 PK			3.53 V	345	105.6	4.2
4	*5720.00	98.6 AV			3.53 V	345	94.4	4.2
5	#5850.00	64.9 PK	74.0	-9.1	3.53 V	345	60.3	4.6
6	#5850.00	52.3 AV	54.0	-1.7	3.53 V	345	47.7	4.6
7	11440.00	46.1 PK	74.0	-27.9	1.67 V	132	32.3	13.8
8	11440.00	33.5 AV	54.0	-20.5	1.67 V	132	19.7	13.8
9	#17160.00	55.9 PK	74.0	-18.1	3.09 V	309	39.5	16.4
10	#17160.00	43.5 AV	54.0	-10.5	3.09 V	309	27.1	16.4

REMARKS:

- Emission Level(dBuV/m) = Raw Value(dBuV) + Correction Factor(dB/m)
- Correction Factor(dB/m) = Antenna Factor(dB/m) + Cable Factor(dB) – Pre-Amplifier Factor(dB)
- The other emission levels were very low against the limit.
- Margin value = Emission Level – Limit value
- " * ": Fundamental frequency.
- " # ": The radiated frequency is out of the restricted band.

802.11ac (VHT40)

CHANNEL	TX Channel 54	DETECTOR FUNCTION	Peak (PK)
FREQUENCY RANGE	1GHz ~ 40GHz		Average (AV)

ANTENNA POLARITY & TEST DISTANCE: HORIZONTAL AT 3 M								
NO.	FREQ. (MHz)	EMISSION LEVEL (dBuV/m)	LIMIT (dBuV/m)	MARGIN (dB)	ANTENNA HEIGHT (m)	TABLE ANGLE (Degree)	RAW VALUE (dBuV)	CORRECTION FACTOR (dB/m)
1	5150.00	59.2 PK	74.0	-14.8	1.98 H	316	55.5	3.7
2	5150.00	43.9 AV	54.0	-10.1	1.98 H	316	40.2	3.7
3	*5270.00	111.6 PK			1.98 H	316	107.6	4.0
4	*5270.00	101.5 AV			1.98 H	316	97.5	4.0
5	#10540.00	46.3 PK	74.0	-27.7	1.63 H	133	33.0	13.3
6	#10540.00	34.3 AV	54.0	-19.7	1.63 H	133	21.0	13.3
7	15810.00	56.6 PK	74.0	-17.4	3.04 H	322	43.2	13.4
8	15810.00	44.0 AV	54.0	-10.0	3.04 H	322	30.6	13.4

ANTENNA POLARITY & TEST DISTANCE: VERTICAL AT 3 M								
NO.	FREQ. (MHz)	EMISSION LEVEL (dBuV/m)	LIMIT (dBuV/m)	MARGIN (dB)	ANTENNA HEIGHT (m)	TABLE ANGLE (Degree)	RAW VALUE (dBuV)	CORRECTION FACTOR (dB/m)
1	5150.00	61.9 PK	74.0	-12.1	1.40 V	335	58.2	3.7
2	5150.00	44.9 AV	54.0	-9.1	1.40 V	335	41.2	3.7
3	*5270.00	113.1 PK			1.40 V	335	109.1	4.0
4	*5270.00	102.3 AV			1.40 V	335	98.3	4.0
5	#10540.00	48.1 PK	74.0	-25.9	2.00 V	10	34.8	13.3
6	#10540.00	35.4 AV	54.0	-18.6	2.00 V	10	22.1	13.3
7	15810.00	56.6 PK	74.0	-17.4	2.31 V	329	43.2	13.4
8	15810.00	44.1 AV	54.0	-9.9	2.31 V	329	30.7	13.4

REMARKS:

1. Emission Level(dBuV/m) = Raw Value(dBuV) + Correction Factor(dB/m)
2. Correction Factor(dB/m) = Antenna Factor(dB/m) + Cable Factor(dB) – Pre-Amplifier Factor(dB)
3. The other emission levels were very low against the limit.
4. Margin value = Emission Level – Limit value
5. " * ": Fundamental frequency.
6. " # ": The radiated frequency is out of the restricted band.

CHANNEL	TX Channel 62	DETECTOR FUNCTION	Peak (PK)
FREQUENCY RANGE	1GHz ~ 40GHz		Average (AV)

ANTENNA POLARITY & TEST DISTANCE: HORIZONTAL AT 3 M

NO.	FREQ. (MHz)	EMISSION LEVEL (dBuV/m)	LIMIT (dBuV/m)	MARGIN (dB)	ANTENNA HEIGHT (m)	TABLE ANGLE (Degree)	RAW VALUE (dBuV)	CORRECTION FACTOR (dB/m)
1	*5310.00	105.6 PK			1.97 H	322	101.5	4.1
2	*5310.00	95.4 AV			1.97 H	322	91.3	4.1
3	5350.00	64.9 PK	74.0	-9.1	1.97 H	322	60.8	4.1
4	5350.00	52.9 AV	54.0	-1.1	1.97 H	322	48.8	4.1
5	10620.00	45.7 PK	74.0	-28.3	1.62 H	134	32.2	13.5
6	10620.00	33.5 AV	54.0	-20.5	1.62 H	134	20.0	13.5
7	15930.00	55.9 PK	74.0	-18.1	3.06 H	310	43.1	12.8
8	15930.00	43.4 AV	54.0	-10.6	3.06 H	310	30.6	12.8

ANTENNA POLARITY & TEST DISTANCE: VERTICAL AT 3 M

NO.	FREQ. (MHz)	EMISSION LEVEL (dBuV/m)	LIMIT (dBuV/m)	MARGIN (dB)	ANTENNA HEIGHT (m)	TABLE ANGLE (Degree)	RAW VALUE (dBuV)	CORRECTION FACTOR (dB/m)
1	*5310.00	107.1 PK			1.39 V	336	103.0	4.1
2	*5310.00	96.2 AV			1.39 V	336	92.1	4.1
3	5350.00	67.6 PK	74.0	-6.4	1.39 V	336	63.5	4.1
4	5350.00	53.9 AV	54.0	-0.1	1.39 V	336	49.8	4.1
5	10620.00	48.5 PK	74.0	-25.5	2.01 V	29	35.0	13.5
6	10620.00	35.5 AV	54.0	-18.5	2.01 V	29	22.0	13.5
7	15930.00	56.4 PK	74.0	-17.6	2.29 V	325	43.6	12.8
8	15930.00	44.1 AV	54.0	-9.9	2.29 V	325	31.3	12.8

REMARKS:

1. Emission Level(dBuV/m) = Raw Value(dBuV) + Correction Factor(dB/m)
2. Correction Factor(dB/m) = Antenna Factor(dB/m) + Cable Factor(dB) – Pre-Amplifier Factor(dB)
3. The other emission levels were very low against the limit.
4. Margin value = Emission Level – Limit value
5. " * ": Fundamental frequency.

CHANNEL	TX Channel 102	DETECTOR FUNCTION	Peak (PK)
FREQUENCY RANGE	1GHz ~ 40GHz		Average (AV)

ANTENNA POLARITY & TEST DISTANCE: HORIZONTAL AT 3 M

NO.	FREQ. (MHz)	EMISSION LEVEL (dBuV/m)	LIMIT (dBuV/m)	MARGIN (dB)	ANTENNA HEIGHT (m)	TABLE ANGLE (Degree)	RAW VALUE (dBuV)	CORRECTION FACTOR (dB/m)
1	#5470.00	72.9 PK	74.0	-1.1	1.80 H	350	68.7	4.2
2	#5470.00	53.8 AV	54.0	-0.2	1.80 H	350	49.6	4.2
3	*5510.00	106.7 PK			1.80 H	350	102.5	4.2
4	*5510.00	97.5 AV			1.80 H	350	93.3	4.2
5	11020.00	49.0 PK	74.0	-25.0	1.92 H	45	35.0	14.0
6	11020.00	35.9 AV	54.0	-18.1	1.92 H	45	21.9	14.0
7	#16530.00	56.6 PK	74.0	-17.4	2.32 H	360	41.7	14.9
8	#16530.00	44.5 AV	54.0	-9.5	2.32 H	360	29.6	14.9

ANTENNA POLARITY & TEST DISTANCE: VERTICAL AT 3 M

NO.	FREQ. (MHz)	EMISSION LEVEL (dBuV/m)	LIMIT (dBuV/m)	MARGIN (dB)	ANTENNA HEIGHT (m)	TABLE ANGLE (Degree)	RAW VALUE (dBuV)	CORRECTION FACTOR (dB/m)
1	#5470.00	69.1 PK	74.0	-4.9	3.48 V	320	64.9	4.2
2	#5470.00	52.1 AV	54.0	-1.9	3.48 V	320	47.9	4.2
3	*5510.00	105.3 PK			3.48 V	320	101.1	4.2
4	*5510.00	95.7 AV			3.48 V	320	91.5	4.2
5	11020.00	46.4 PK	74.0	-27.6	1.74 V	146	32.4	14.0
6	11020.00	33.8 AV	54.0	-20.2	1.74 V	146	19.8	14.0
7	#16530.00	56.0 PK	74.0	-18.0	3.09 V	312	41.1	14.9
8	#16530.00	43.5 AV	54.0	-10.5	3.09 V	312	28.6	14.9

REMARKS:

1. Emission Level(dBuV/m) = Raw Value(dBuV) + Correction Factor(dB/m)
2. Correction Factor(dB/m) = Antenna Factor(dB/m) + Cable Factor(dB) – Pre-Amplifier Factor(dB)
3. The other emission levels were very low against the limit.
4. Margin value = Emission Level – Limit value
5. " * ": Fundamental frequency.
6. " # ": The radiated frequency is out of the restricted band.

CHANNEL	TX Channel 110	DETECTOR FUNCTION	Peak (PK)
FREQUENCY RANGE	1GHz ~ 40GHz		Average (AV)

ANTENNA POLARITY & TEST DISTANCE: HORIZONTAL AT 3 M

NO.	FREQ. (MHz)	EMISSION LEVEL (dBuV/m)	LIMIT (dBuV/m)	MARGIN (dB)	ANTENNA HEIGHT (m)	TABLE ANGLE (Degree)	RAW VALUE (dBuV)	CORRECTION FACTOR (dB/m)
1	#5470.00	69.3 PK	74.0	-4.7	1.79 H	348	65.1	4.2
2	#5470.00	53.9 AV	54.0	-0.1	1.79 H	348	49.7	4.2
3	*5550.00	112.3 PK			1.79 H	348	108.1	4.2
4	*5550.00	102.9 AV			1.79 H	348	98.7	4.2
5	11100.00	48.6 PK	74.0	-25.4	1.96 H	48	34.8	13.8
6	11100.00	35.6 AV	54.0	-18.4	1.96 H	48	21.8	13.8
7	#16650.00	56.5 PK	74.0	-17.5	2.28 H	360	40.9	15.6
8	#16650.00	44.3 AV	54.0	-9.7	2.28 H	360	28.7	15.6

ANTENNA POLARITY & TEST DISTANCE: VERTICAL AT 3 M

NO.	FREQ. (MHz)	EMISSION LEVEL (dBuV/m)	LIMIT (dBuV/m)	MARGIN (dB)	ANTENNA HEIGHT (m)	TABLE ANGLE (Degree)	RAW VALUE (dBuV)	CORRECTION FACTOR (dB/m)
1	#5470.00	65.5 PK	74.0	-8.5	3.47 V	327	61.3	4.2
2	#5470.00	52.2 AV	54.0	-1.8	3.47 V	327	48.0	4.2
3	*5550.00	110.9 PK			3.47 V	327	106.7	4.2
4	*5550.00	101.1 AV			3.47 V	327	96.9	4.2
5	11100.00	46.1 PK	74.0	-27.9	1.74 V	129	32.3	13.8
6	11100.00	33.4 AV	54.0	-20.6	1.74 V	129	19.6	13.8
7	#16650.00	55.9 PK	74.0	-18.1	3.11 V	299	40.3	15.6
8	#16650.00	43.5 AV	54.0	-10.5	3.11 V	299	27.9	15.6

REMARKS:

1. Emission Level(dBuV/m) = Raw Value(dBuV) + Correction Factor(dB/m)
2. Correction Factor(dB/m) = Antenna Factor(dB/m) + Cable Factor(dB) – Pre-Amplifier Factor(dB)
3. The other emission levels were very low against the limit.
4. Margin value = Emission Level – Limit value
5. " * ": Fundamental frequency.
6. " # ": The radiated frequency is out of the restricted band.

CHANNEL	TX Channel 134	DETECTOR FUNCTION	Peak (PK)
FREQUENCY RANGE	1GHz ~ 40GHz		Average (AV)

ANTENNA POLARITY & TEST DISTANCE: HORIZONTAL AT 3 M

NO.	FREQ. (MHz)	EMISSION LEVEL (dBuV/m)	LIMIT (dBuV/m)	MARGIN (dB)	ANTENNA HEIGHT (m)	TABLE ANGLE (Degree)	RAW VALUE (dBuV)	CORRECTION FACTOR (dB/m)
1	*5670.00	108.7 PK			1.83 H	351	104.4	4.3
2	*5670.00	99.0 AV			1.83 H	351	94.7	4.3
3	#5725.00	67.9 PK	74.0	-6.1	1.83 H	351	63.5	4.4
4	#5725.00	53.7 AV	54.0	-0.3	1.83 H	351	49.3	4.4
5	11340.00	49.0 PK	74.0	-25.0	1.99 H	20	35.4	13.6
6	11340.00	35.7 AV	54.0	-18.3	1.99 H	20	22.1	13.6
7	#17010.00	56.2 PK	74.0	-17.8	2.30 H	341	39.1	17.1
8	#17010.00	43.9 AV	54.0	-10.1	2.30 H	341	26.8	17.1

ANTENNA POLARITY & TEST DISTANCE: VERTICAL AT 3 M

NO.	FREQ. (MHz)	EMISSION LEVEL (dBuV/m)	LIMIT (dBuV/m)	MARGIN (dB)	ANTENNA HEIGHT (m)	TABLE ANGLE (Degree)	RAW VALUE (dBuV)	CORRECTION FACTOR (dB/m)
1	*5670.00	107.3 PK			3.55 V	319	103.0	4.3
2	*5670.00	97.2 AV			3.55 V	319	92.9	4.3
3	#5725.00	64.1 PK	74.0	-9.9	3.55 V	319	59.7	4.4
4	#5725.00	51.8 AV	54.0	-2.2	3.55 V	319	47.4	4.4
5	11340.00	46.3 PK	74.0	-27.7	1.63 V	139	32.7	13.6
6	11340.00	34.2 AV	54.0	-19.8	1.63 V	139	20.6	13.6
7	#17010.00	56.0 PK	74.0	-18.0	3.08 V	319	38.9	17.1
8	#17010.00	43.6 AV	54.0	-10.4	3.08 V	319	26.5	17.1

REMARKS:

1. Emission Level(dBuV/m) = Raw Value(dBuV) + Correction Factor(dB/m)
2. Correction Factor(dB/m) = Antenna Factor(dB/m) + Cable Factor(dB) – Pre-Amplifier Factor(dB)
3. The other emission levels were very low against the limit.
4. Margin value = Emission Level – Limit value
5. " * ": Fundamental frequency.
6. " # ": The radiated frequency is out of the restricted band.

CHANNEL	TX Channel 142	DETECTOR FUNCTION	Peak (PK)
FREQUENCY RANGE	1GHz ~ 40GHz		Average (AV)

ANTENNA POLARITY & TEST DISTANCE: HORIZONTAL AT 3 M

NO.	FREQ. (MHz)	EMISSION LEVEL (dBuV/m)	LIMIT (dBuV/m)	MARGIN (dB)	ANTENNA HEIGHT (m)	TABLE ANGLE (Degree)	RAW VALUE (dBuV)	CORRECTION FACTOR (dB/m)
1	#5470.00	51.3 PK	74.0	-22.7	1.84 H	335	47.3	4.0
2	#5470.00	40.3 AV	54.0	-13.7	1.84 H	335	36.3	4.0
3	*5710.00	109.1 PK			1.84 H	335	104.8	4.3
4	*5710.00	99.2 AV			1.84 H	335	94.9	4.3
5	#5850.00	67.5 PK	74.0	-6.5	1.84 H	335	62.9	4.6
6	#5850.00	53.6 AV	54.0	-0.4	1.84 H	335	49.0	4.6
7	11420.00	48.3 PK	74.0	-25.7	1.93 H	7	34.5	13.8
8	11420.00	35.3 AV	54.0	-18.7	1.93 H	7	21.5	13.8
9	#17130.00	55.6 PK	74.0	-18.4	2.32 H	352	39.1	16.5
10	#17130.00	43.5 AV	54.0	-10.5	2.32 H	352	27.0	16.5

ANTENNA POLARITY & TEST DISTANCE: VERTICAL AT 3 M

NO.	FREQ. (MHz)	EMISSION LEVEL (dBuV/m)	LIMIT (dBuV/m)	MARGIN (dB)	ANTENNA HEIGHT (m)	TABLE ANGLE (Degree)	RAW VALUE (dBuV)	CORRECTION FACTOR (dB/m)
1	#5470.00	47.8 PK	74.0	-26.2	3.58 V	316	43.8	4.0
2	#5470.00	38.6 AV	54.0	-15.4	3.58 V	316	34.6	4.0
3	*5710.00	107.4 PK			3.58 V	316	103.1	4.3
4	*5710.00	97.4 AV			3.58 V	316	93.1	4.3
5	#5850.00	63.4 PK	74.0	-10.6	3.58 V	316	58.8	4.6
6	#5850.00	51.4 AV	54.0	-2.6	3.58 V	316	46.8	4.6
7	11420.00	46.3 PK	74.0	-27.7	1.66 V	125	32.5	13.8
8	11420.00	34.4 AV	54.0	-19.6	1.66 V	125	20.6	13.8
9	#17130.00	55.9 PK	74.0	-18.1	3.05 V	330	39.4	16.5
10	#17130.00	43.5 AV	54.0	-10.5	3.05 V	330	27.0	16.5

REMARKS:

1. Emission Level(dBuV/m) = Raw Value(dBuV) + Correction Factor(dB/m)
2. Correction Factor(dB/m) = Antenna Factor(dB/m) + Cable Factor(dB) – Pre-Amplifier Factor(dB)
3. The other emission levels were very low against the limit.
4. Margin value = Emission Level – Limit value
5. " * ": Fundamental frequency.
6. " # ": The radiated frequency is out of the restricted band.

802.11ac (VHT80)

CHANNEL	TX Channel 58	DETECTOR FUNCTION	Peak (PK)
FREQUENCY RANGE	1GHz ~ 40GHz		Average (AV)

ANTENNA POLARITY & TEST DISTANCE: HORIZONTAL AT 3 M

NO.	FREQ. (MHz)	EMISSION LEVEL (dBuV/m)	LIMIT (dBuV/m)	MARGIN (dB)	ANTENNA HEIGHT (m)	TABLE ANGLE (Degree)	RAW VALUE (dBuV)	CORRECTION FACTOR (dB/m)
1	5150.00	48.8 PK	74.0	-25.2	1.86 H	318	45.1	3.7
2	5150.00	39.6 AV	54.0	-14.4	1.86 H	318	35.9	3.7
3	*5290.00	98.6 PK			1.86 H	318	94.5	4.1
4	*5290.00	90.3 AV			1.86 H	318	86.2	4.1
5	5350.00	64.6 PK	74.0	-9.4	1.86 H	318	60.5	4.1
6	5350.00	53.3 AV	54.0	-0.7	1.86 H	318	49.2	4.1
7	#10580.00	46.4 PK	74.0	-27.6	1.55 H	142	33.0	13.4
8	#10580.00	34.0 AV	54.0	-20.0	1.55 H	142	20.6	13.4
9	15870.00	55.6 PK	74.0	-18.4	3.07 H	304	42.6	13.0
10	15870.00	43.5 AV	54.0	-10.5	3.07 H	304	30.5	13.0

ANTENNA POLARITY & TEST DISTANCE: VERTICAL AT 3 M

NO.	FREQ. (MHz)	EMISSION LEVEL (dBuV/m)	LIMIT (dBuV/m)	MARGIN (dB)	ANTENNA HEIGHT (m)	TABLE ANGLE (Degree)	RAW VALUE (dBuV)	CORRECTION FACTOR (dB/m)
1	5150.00	51.3 PK	74.0	-22.7	1.39 V	335	47.6	3.7
2	5150.00	40.9 AV	54.0	-13.1	1.39 V	335	37.2	3.7
3	*5290.00	101.6 PK			1.39 V	335	97.5	4.1
4	*5290.00	92.3 AV			1.39 V	335	88.2	4.1
5	5350.00	66.5 PK	74.0	-7.5	1.39 V	335	62.4	4.1
6	5350.00	53.9 AV	54.0	-0.1	1.39 V	335	49.8	4.1
7	#10580.00	48.6 PK	74.0	-25.4	1.95 V	25	35.2	13.4
8	#10580.00	35.5 AV	54.0	-18.5	1.95 V	25	22.1	13.4
9	15870.00	56.7 PK	74.0	-17.3	2.26 V	338	43.7	13.0
10	15870.00	44.3 AV	54.0	-9.7	2.26 V	338	31.3	13.0

REMARKS:

1. Emission Level(dBuV/m) = Raw Value(dBuV) + Correction Factor(dB/m)
2. Correction Factor(dB/m) = Antenna Factor(dB/m) + Cable Factor(dB) – Pre-Amplifier Factor(dB)
3. The other emission levels were very low against the limit.
4. Margin value = Emission Level – Limit value
5. " * ": Fundamental frequency.
6. " # ": The radiated frequency is out of the restricted band.

CHANNEL	TX Channel 106	DETECTOR FUNCTION	Peak (PK)
FREQUENCY RANGE	1GHz ~ 40GHz		Average (AV)

ANTENNA POLARITY & TEST DISTANCE: HORIZONTAL AT 3 M

NO.	FREQ. (MHz)	EMISSION LEVEL (dBuV/m)	LIMIT (dBuV/m)	MARGIN (dB)	ANTENNA HEIGHT (m)	TABLE ANGLE (Degree)	RAW VALUE (dBuV)	CORRECTION FACTOR (dB/m)
1	#5470.00	72.6 PK	74.0	-1.4	1.95 H	348	68.4	4.2
2	#5470.00	53.9 AV	54.0	-0.1	1.95 H	348	49.7	4.2
3	*5530.00	103.8 PK			1.95 H	348	99.6	4.2
4	*5530.00	94.6 AV			1.95 H	348	90.4	4.2
5	#5725.00	51.2 PK	74.0	-22.8	1.95 H	348	46.8	4.4
6	#5725.00	40.3 AV	54.0	-13.7	1.95 H	348	35.9	4.4
7	11060.00	48.3 PK	74.0	-25.7	1.93 H	29	34.4	13.9
8	11060.00	35.2 AV	54.0	-18.8	1.93 H	29	21.3	13.9
9	#16590.00	57.0 PK	74.0	-17.0	2.33 H	338	41.4	15.6
10	#16590.00	44.6 AV	54.0	-9.4	2.33 H	338	29.0	15.6

ANTENNA POLARITY & TEST DISTANCE: VERTICAL AT 3 M

NO.	FREQ. (MHz)	EMISSION LEVEL (dBuV/m)	LIMIT (dBuV/m)	MARGIN (dB)	ANTENNA HEIGHT (m)	TABLE ANGLE (Degree)	RAW VALUE (dBuV)	CORRECTION FACTOR (dB/m)
1	#5470.00	68.8 PK	74.0	-5.2	3.48 V	331	64.6	4.2
2	#5470.00	52.0 AV	54.0	-2.0	3.48 V	331	47.8	4.2
3	*5530.00	101.4 PK			3.48 V	331	97.2	4.2
4	*5530.00	92.8 AV			3.48 V	331	88.6	4.2
5	#5725.00	47.4 PK	74.0	-26.6	3.48 V	331	43.0	4.4
6	#5725.00	38.4 AV	54.0	-15.6	3.48 V	331	34.0	4.4
7	11060.00	46.1 PK	74.0	-27.9	1.74 V	151	32.2	13.9
8	11060.00	33.6 AV	54.0	-20.4	1.74 V	151	19.7	13.9
9	#16590.00	56.1 PK	74.0	-17.9	3.19 V	304	40.5	15.6
10	#16590.00	43.4 AV	54.0	-10.6	3.19 V	304	27.8	15.6

REMARKS:

1. Emission Level(dBuV/m) = Raw Value(dBuV) + Correction Factor(dB/m)
2. Correction Factor(dB/m) = Antenna Factor(dB/m) + Cable Factor(dB) – Pre-Amplifier Factor(dB)
3. The other emission levels were very low against the limit.
4. Margin value = Emission Level – Limit value
5. " * ": Fundamental frequency.
6. " # ": The radiated frequency is out of the restricted band.

CHANNEL	TX Channel 122	DETECTOR FUNCTION	Peak (PK)
FREQUENCY RANGE	1GHz ~ 40GHz		Average (AV)

ANTENNA POLARITY & TEST DISTANCE: HORIZONTAL AT 3 M

NO.	FREQ. (MHz)	EMISSION LEVEL (dBuV/m)	LIMIT (dBuV/m)	MARGIN (dB)	ANTENNA HEIGHT (m)	TABLE ANGLE (Degree)	RAW VALUE (dBuV)	CORRECTION FACTOR (dB/m)
1	*5610.00	105.1 PK			1.94 H	350	100.7	4.4
2	*5610.00	95.8 AV			1.94 H	350	91.4	4.4
3	#5725.00	66.5 PK	74.0	-7.5	1.94 H	350	62.1	4.4
4	#5725.00	53.7 AV	54.0	-0.3	1.94 H	350	49.3	4.4
5	11220.00	48.7 PK	74.0	-25.3	1.97 H	28	35.0	13.7
6	11220.00	35.8 AV	54.0	-18.2	1.97 H	28	22.1	13.7
7	#16830.00	56.0 PK	74.0	-18.0	2.36 H	357	40.1	15.9
8	#16830.00	43.9 AV	54.0	-10.1	2.36 H	357	28.0	15.9

ANTENNA POLARITY & TEST DISTANCE: VERTICAL AT 3 M

NO.	FREQ. (MHz)	EMISSION LEVEL (dBuV/m)	LIMIT (dBuV/m)	MARGIN (dB)	ANTENNA HEIGHT (m)	TABLE ANGLE (Degree)	RAW VALUE (dBuV)	CORRECTION FACTOR (dB/m)
1	*5610.00	102.7 PK			3.52 V	316	98.3	4.4
2	*5610.00	94.0 AV			3.52 V	316	89.6	4.4
3	#5725.00	62.7 PK	74.0	-11.3	3.52 V	316	58.3	4.4
4	#5725.00	51.8 AV	54.0	-2.2	3.52 V	316	47.4	4.4
5	11220.00	45.7 PK	74.0	-28.3	1.67 V	132	32.0	13.7
6	11220.00	33.4 AV	54.0	-20.6	1.67 V	132	19.7	13.7
7	#16830.00	55.7 PK	74.0	-18.3	3.09 V	321	39.8	15.9
8	#16830.00	43.4 AV	54.0	-10.6	3.09 V	321	27.5	15.9

REMARKS:

1. Emission Level(dBuV/m) = Raw Value(dBuV) + Correction Factor(dB/m)
2. Correction Factor(dB/m) = Antenna Factor(dB/m) + Cable Factor(dB) – Pre-Amplifier Factor(dB)
3. The other emission levels were very low against the limit.
4. Margin value = Emission Level – Limit value
5. " * ": Fundamental frequency.
6. " # ": The radiated frequency is out of the restricted band.

CHANNEL	TX Channel 138	DETECTOR FUNCTION	Peak (PK)
FREQUENCY RANGE	1GHz ~ 40GHz		Average (AV)

ANTENNA POLARITY & TEST DISTANCE: HORIZONTAL AT 3 M

NO.	FREQ. (MHz)	EMISSION LEVEL (dBuV/m)	LIMIT (dBuV/m)	MARGIN (dB)	ANTENNA HEIGHT (m)	TABLE ANGLE (Degree)	RAW VALUE (dBuV)	CORRECTION FACTOR (dB/m)
1	#5470.00	51.1 PK	74.0	-22.9	1.98 H	354	47.1	4.0
2	#5470.00	40.5 AV	54.0	-13.5	1.98 H	354	36.5	4.0
3	*5690.00	104.8 PK			1.98 H	354	100.6	4.2
4	*5690.00	95.5 AV			1.98 H	354	91.3	4.2
5	#5850.00	66.7 PK	74.0	-7.3	1.98 H	354	62.1	4.6
6	#5850.00	53.8 AV	54.0	-0.2	1.98 H	354	49.2	4.6
7	11380.00	49.4 PK	74.0	-24.6	2.01 H	35	35.7	13.7
8	11380.00	36.2 AV	54.0	-17.8	2.01 H	35	22.5	13.7
9	#17070.00	56.3 PK	74.0	-17.7	2.33 H	360	39.7	16.6
10	#17070.00	44.0 AV	54.0	-10.0	2.33 H	360	27.4	16.6

ANTENNA POLARITY & TEST DISTANCE: VERTICAL AT 3 M

NO.	FREQ. (MHz)	EMISSION LEVEL (dBuV/m)	LIMIT (dBuV/m)	MARGIN (dB)	ANTENNA HEIGHT (m)	TABLE ANGLE (Degree)	RAW VALUE (dBuV)	CORRECTION FACTOR (dB/m)
1	#5470.00	47.9 PK	74.0	-26.1	3.57 V	321	43.9	4.0
2	#5470.00	38.7 AV	54.0	-15.3	3.57 V	321	34.7	4.0
3	*5690.00	102.3 PK			3.57 V	321	98.1	4.2
4	*5690.00	93.9 AV			3.57 V	321	89.7	4.2
5	#5850.00	62.8 PK	74.0	-11.2	3.57 V	321	58.2	4.6
6	#5850.00	51.9 AV	54.0	-2.1	3.57 V	321	47.3	4.6
7	11380.00	45.8 PK	74.0	-28.2	1.71 V	119	32.1	13.7
8	11380.00	33.6 AV	54.0	-20.4	1.71 V	119	19.9	13.7
9	#17070.00	55.9 PK	74.0	-18.1	3.08 V	323	39.3	16.6
10	#17070.00	43.4 AV	54.0	-10.6	3.08 V	323	26.8	16.6

REMARKS:

1. Emission Level(dBuV/m) = Raw Value(dBuV) + Correction Factor(dB/m)
2. Correction Factor(dB/m) = Antenna Factor(dB/m) + Cable Factor(dB) – Pre-Amplifier Factor(dB)
3. The other emission levels were very low against the limit.
4. Margin value = Emission Level – Limit value
5. " * ": Fundamental frequency.
6. " # ": The radiated frequency is out of the restricted band.

Below 1GHz Data:

802.11ac (VHT20)

CHANNEL	TX Channel 140	DETECTOR FUNCTION	Quasi-Peak (QP)
FREQUENCY RANGE	9kHz ~ 1GHz		

ANTENNA POLARITY & TEST DISTANCE: HORIZONTAL AT 3 M

NO.	FREQ. (MHz)	EMISSION LEVEL (dBuV/m)	LIMIT (dBuV/m)	MARGIN (dB)	ANTENNA HEIGHT (m)	TABLE ANGLE (Degree)	RAW VALUE (dBuV)	CORRECTION FACTOR (dB/m)
1	88.30	32.8 QP	43.5	-10.7	2.00 H	0	47.0	-14.2
2	114.46	32.3 QP	43.5	-11.2	3.00 H	251	43.0	-10.7
3	222.38	31.1 QP	46.0	-14.9	2.00 H	310	42.2	-11.1
4	347.24	34.9 QP	46.0	-11.1	1.00 H	298	41.4	-6.5
5	389.94	36.9 QP	46.0	-9.1	1.00 H	306	42.5	-5.6
6	477.10	34.7 QP	46.0	-11.3	3.00 H	127	38.2	-3.5

ANTENNA POLARITY & TEST DISTANCE: VERTICAL AT 3 M

NO.	FREQ. (MHz)	EMISSION LEVEL (dBuV/m)	LIMIT (dBuV/m)	MARGIN (dB)	ANTENNA HEIGHT (m)	TABLE ANGLE (Degree)	RAW VALUE (dBuV)	CORRECTION FACTOR (dB/m)
1	34.90	36.6 QP	40.0	-3.4	1.00 V	329	45.7	-9.1
2	111.53	31.7 QP	43.5	-11.8	1.00 V	27	42.6	-10.9
3	224.10	29.0 QP	46.0	-17.0	2.00 V	2	40.0	-11.0
4	351.31	40.7 QP	46.0	-5.3	2.00 V	360	47.2	-6.5
5	387.28	41.0 QP	46.0	-5.0	1.00 V	84	46.7	-5.7
6	478.92	36.5 QP	46.0	-9.5	2.00 V	360	40.0	-3.5

REMARKS:

1. Emission Level(dBuV/m) = Raw Value(dBuV) + Correction Factor(dB/m)
2. Correction Factor(dB/m) = Antenna Factor(dB/m) + Cable Factor(dB) – Pre-Amplifier Factor(dB)
3. The other emission levels were very low against the limit.
4. Margin value = Emission Level – Limit value

Sector Antenna

Above 1GHz Data:

802.11a

CHANNEL	TX Channel 52	DETECTOR FUNCTION	Peak (PK)
FREQUENCY RANGE	1GHz ~ 40GHz		Average (AV)

ANTENNA POLARITY & TEST DISTANCE: HORIZONTAL AT 3 M

NO.	FREQ. (MHz)	EMISSION LEVEL (dBuV/m)	LIMIT (dBuV/m)	MARGIN (dB)	ANTENNA HEIGHT (m)	TABLE ANGLE (Degree)	RAW VALUE (dBuV)	CORRECTION FACTOR (dB/m)
1	5150.00	51.1 PK	74.0	-22.9	1.53 H	350	47.4	3.7
2	5150.00	38.6 AV	54.0	-15.4	1.53 H	350	34.9	3.7
3	*5260.00	112.4 PK			1.53 H	350	108.4	4.0
4	*5260.00	101.8 AV			1.53 H	350	97.8	4.0
5	#10520.00	57.8 PK	74.0	-16.2	1.43 H	127	44.6	13.2
6	#10520.00	44.3 AV	54.0	-9.7	1.43 H	127	31.1	13.2
7	15780.00	55.0 PK	74.0	-19.0	3.05 H	297	41.4	13.6
8	15780.00	43.0 AV	54.0	-11.0	3.05 H	297	29.4	13.6

ANTENNA POLARITY & TEST DISTANCE: VERTICAL AT 3 M

NO.	FREQ. (MHz)	EMISSION LEVEL (dBuV/m)	LIMIT (dBuV/m)	MARGIN (dB)	ANTENNA HEIGHT (m)	TABLE ANGLE (Degree)	RAW VALUE (dBuV)	CORRECTION FACTOR (dB/m)
1	5150.00	52.7 PK	74.0	-21.3	2.74 V	360	49.0	3.7
2	5150.00	39.9 AV	54.0	-14.1	2.74 V	360	36.2	3.7
3	*5260.00	112.9 PK			2.74 V	360	108.9	4.0
4	*5260.00	103.0 AV			2.74 V	360	99.0	4.0
5	#10520.00	59.6 PK	74.0	-14.4	1.86 V	41	46.4	13.2
6	#10520.00	46.5 AV	54.0	-7.5	1.86 V	41	33.3	13.2
7	15780.00	55.3 PK	74.0	-18.7	2.42 V	360	41.7	13.6
8	15780.00	44.5 AV	54.0	-9.5	2.42 V	360	30.9	13.6

REMARKS:

- Emission Level(dBuV/m) = Raw Value(dBuV) + Correction Factor(dB/m)
- Correction Factor(dB/m) = Antenna Factor(dB/m) + Cable Factor(dB) – Pre-Amplifier Factor(dB)
- The other emission levels were very low against the limit.
- Margin value = Emission Level – Limit value
- " * ": Fundamental frequency.
- " # ": The radiated frequency is out of the restricted band.

CHANNEL	TX Channel 60	DETECTOR FUNCTION	Peak (PK)
FREQUENCY RANGE	1GHz ~ 40GHz		Average (AV)

ANTENNA POLARITY & TEST DISTANCE: HORIZONTAL AT 3 M

NO.	FREQ. (MHz)	EMISSION LEVEL (dBuV/m)	LIMIT (dBuV/m)	MARGIN (dB)	ANTENNA HEIGHT (m)	TABLE ANGLE (Degree)	RAW VALUE (dBuV)	CORRECTION FACTOR (dB/m)
1	5150.00	49.3 PK	74.0	-24.7	1.51 H	348	45.6	3.7
2	5150.00	36.6 AV	54.0	-17.4	1.51 H	348	32.9	3.7
3	*5300.00	112.4 PK			1.51 H	348	108.3	4.1
4	*5300.00	101.7 AV			1.51 H	348	97.6	4.1
5	5350.00	61.5 PK	74.0	-12.5	1.51 H	348	57.4	4.1
6	5350.00	41.7 AV	54.0	-12.3	1.51 H	348	37.6	4.1
7	10600.00	58.2 PK	74.0	-15.8	1.48 H	122	44.7	13.5
8	10600.00	44.7 AV	54.0	-9.3	1.48 H	122	31.2	13.5
9	15900.00	55.2 PK	74.0	-18.8	3.05 H	316	42.3	12.9
10	15900.00	43.2 AV	54.0	-10.8	3.05 H	316	30.3	12.9

ANTENNA POLARITY & TEST DISTANCE: VERTICAL AT 3 M

NO.	FREQ. (MHz)	EMISSION LEVEL (dBuV/m)	LIMIT (dBuV/m)	MARGIN (dB)	ANTENNA HEIGHT (m)	TABLE ANGLE (Degree)	RAW VALUE (dBuV)	CORRECTION FACTOR (dB/m)
1	5150.00	50.9 PK	74.0	-23.1	2.75 V	354	47.2	3.7
2	5150.00	37.9 AV	54.0	-16.1	2.75 V	354	34.2	3.7
3	*5300.00	112.9 PK			2.75 V	354	108.8	4.1
4	*5300.00	102.9 AV			2.75 V	354	98.8	4.1
5	5350.00	63.1 PK	74.0	-10.9	2.75 V	354	59.0	4.1
6	5350.00	43.0 AV	54.0	-11.0	2.75 V	354	38.9	4.1
7	10600.00	59.0 PK	74.0	-15.0	1.84 V	53	45.5	13.5
8	10600.00	46.1 AV	54.0	-7.9	1.84 V	53	32.6	13.5
9	15900.00	54.8 PK	74.0	-19.2	2.47 V	360	41.9	12.9
10	15900.00	44.1 AV	54.0	-9.9	2.47 V	360	31.2	12.9

REMARKS:

1. Emission Level(dBuV/m) = Raw Value(dBuV) + Correction Factor(dB/m)
2. Correction Factor(dB/m) = Antenna Factor(dB/m) + Cable Factor(dB) – Pre-Amplifier Factor(dB)
3. The other emission levels were very low against the limit.
4. Margin value = Emission Level – Limit value
5. " * ": Fundamental frequency.

CHANNEL	TX Channel 64	DETECTOR FUNCTION	Peak (PK)
FREQUENCY RANGE	1GHz ~ 40GHz		Average (AV)

ANTENNA POLARITY & TEST DISTANCE: HORIZONTAL AT 3 M

NO.	FREQ. (MHz)	EMISSION LEVEL (dBuV/m)	LIMIT (dBuV/m)	MARGIN (dB)	ANTENNA HEIGHT (m)	TABLE ANGLE (Degree)	RAW VALUE (dBuV)	CORRECTION FACTOR (dB/m)
1	*5320.00	109.3 PK			1.57 H	344	105.2	4.1
2	*5320.00	98.7 AV			1.57 H	344	94.6	4.1
3	5350.00	70.0 PK	74.0	-4.0	1.57 H	344	65.9	4.1
4	5350.00	52.5 AV	54.0	-1.5	1.57 H	344	48.4	4.1
5	10640.00	58.6 PK	74.0	-15.4	1.50 H	138	45.1	13.5
6	10640.00	44.8 AV	54.0	-9.2	1.50 H	138	31.3	13.5
7	15960.00	56.0 PK	74.0	-18.0	3.13 H	299	43.1	12.9
8	15960.00	43.4 AV	54.0	-10.6	3.13 H	299	30.5	12.9

ANTENNA POLARITY & TEST DISTANCE: VERTICAL AT 3 M

NO.	FREQ. (MHz)	EMISSION LEVEL (dBuV/m)	LIMIT (dBuV/m)	MARGIN (dB)	ANTENNA HEIGHT (m)	TABLE ANGLE (Degree)	RAW VALUE (dBuV)	CORRECTION FACTOR (dB/m)
1	*5320.00	109.8 PK			2.78 V	350	105.7	4.1
2	*5320.00	99.9 AV			2.78 V	350	95.8	4.1
3	5350.00	71.6 PK	74.0	-2.4	2.73 V	353	67.5	4.1
4	5350.00	53.8 AV	54.0	-0.2	2.73 V	353	49.7	4.1
5	10640.00	59.9 PK	74.0	-14.1	1.87 V	34	46.4	13.5
6	10640.00	46.6 AV	54.0	-7.4	1.87 V	34	33.1	13.5
7	15960.00	55.4 PK	74.0	-18.6	2.40 V	359	42.5	12.9
8	15960.00	44.5 AV	54.0	-9.5	2.40 V	359	31.6	12.9

REMARKS:

1. Emission Level(dBuV/m) = Raw Value(dBuV) + Correction Factor(dB/m)
2. Correction Factor(dB/m) = Antenna Factor(dB/m) + Cable Factor(dB) – Pre-Amplifier Factor(dB)
3. The other emission levels were very low against the limit.
4. Margin value = Emission Level – Limit value
5. " * ": Fundamental frequency.

CHANNEL	TX Channel 100	DETECTOR FUNCTION	Peak (PK)
FREQUENCY RANGE	1GHz ~ 40GHz		Average (AV)

ANTENNA POLARITY & TEST DISTANCE: HORIZONTAL AT 3 M

NO.	FREQ. (MHz)	EMISSION LEVEL (dBuV/m)	LIMIT (dBuV/m)	MARGIN (dB)	ANTENNA HEIGHT (m)	TABLE ANGLE (Degree)	RAW VALUE (dBuV)	CORRECTION FACTOR (dB/m)
1	#5470.00	72.5 PK	74.0	-1.5	1.86 H	360	68.3	4.2
2	#5470.00	53.9 AV	54.0	-0.1	1.86 H	360	49.7	4.2
3	*5500.00	111.4 PK			1.86 H	360	107.2	4.2
4	*5500.00	100.2 AV			1.86 H	360	96.0	4.2
5	11000.00	48.6 PK	74.0	-25.4	1.98 H	8	34.5	14.1
6	11000.00	35.7 AV	54.0	-18.3	1.98 H	8	21.6	14.1
7	#16500.00	57.5 PK	74.0	-16.5	2.24 H	339	43.0	14.5
8	#16500.00	44.7 AV	54.0	-9.3	2.24 H	339	30.2	14.5

ANTENNA POLARITY & TEST DISTANCE: VERTICAL AT 3 M

NO.	FREQ. (MHz)	EMISSION LEVEL (dBuV/m)	LIMIT (dBuV/m)	MARGIN (dB)	ANTENNA HEIGHT (m)	TABLE ANGLE (Degree)	RAW VALUE (dBuV)	CORRECTION FACTOR (dB/m)
1	#5470.00	69.1 PK	74.0	-4.9	3.51 V	306	64.9	4.2
2	#5470.00	52.2 AV	54.0	-1.8	3.51 V	306	48.0	4.2
3	*5500.00	110.6 PK			3.51 V	306	106.4	4.2
4	*5500.00	99.3 AV			3.51 V	306	95.1	4.2
5	11000.00	46.7 PK	74.0	-27.3	1.68 V	151	32.6	14.1
6	11000.00	34.3 AV	54.0	-19.7	1.68 V	151	20.2	14.1
7	#16500.00	56.2 PK	74.0	-17.8	3.11 V	322	41.7	14.5
8	#16500.00	43.5 AV	54.0	-10.5	3.11 V	322	29.0	14.5

REMARKS:

1. Emission Level(dBuV/m) = Raw Value(dBuV) + Correction Factor(dB/m)
2. Correction Factor(dB/m) = Antenna Factor(dB/m) + Cable Factor(dB) – Pre-Amplifier Factor(dB)
3. The other emission levels were very low against the limit.
4. Margin value = Emission Level – Limit value
5. " * ": Fundamental frequency.
6. " # ": The radiated frequency is out of the restricted band.

CHANNEL	TX Channel 116	DETECTOR FUNCTION	Peak (PK)
FREQUENCY RANGE	1GHz ~ 40GHz		Average (AV)

ANTENNA POLARITY & TEST DISTANCE: HORIZONTAL AT 3 M

NO.	FREQ. (MHz)	EMISSION LEVEL (dBuV/m)	LIMIT (dBuV/m)	MARGIN (dB)	ANTENNA HEIGHT (m)	TABLE ANGLE (Degree)	RAW VALUE (dBuV)	CORRECTION FACTOR (dB/m)
1	*5580.00	112.9 PK			1.85 H	360	108.7	4.2
2	*5580.00	103.2 AV			1.85 H	360	99.0	4.2
3	11160.00	48.6 PK	74.0	-25.4	1.95 H	50	34.9	13.7
4	11160.00	35.3 AV	54.0	-18.7	1.95 H	50	21.6	13.7
5	#16740.00	56.6 PK	74.0	-17.4	2.25 H	357	40.9	15.7
6	#16740.00	44.3 AV	54.0	-9.7	2.25 H	357	28.6	15.7

ANTENNA POLARITY & TEST DISTANCE: VERTICAL AT 3 M

NO.	FREQ. (MHz)	EMISSION LEVEL (dBuV/m)	LIMIT (dBuV/m)	MARGIN (dB)	ANTENNA HEIGHT (m)	TABLE ANGLE (Degree)	RAW VALUE (dBuV)	CORRECTION FACTOR (dB/m)
1	*5580.00	110.5 PK			3.55 V	312	106.3	4.2
2	*5580.00	100.7 AV			3.55 V	312	96.5	4.2
3	11160.00	46.1 PK	74.0	-27.9	1.60 V	134	32.4	13.7
4	11160.00	34.0 AV	54.0	-20.0	1.60 V	134	20.3	13.7
5	#16740.00	56.3 PK	74.0	-17.7	3.04 V	313	40.6	15.7
6	#16740.00	43.8 AV	54.0	-10.2	3.04 V	313	28.1	15.7

REMARKS:

1. Emission Level(dBuV/m) = Raw Value(dBuV) + Correction Factor(dB/m)
2. Correction Factor(dB/m) = Antenna Factor(dB/m) + Cable Factor(dB) – Pre-Amplifier Factor(dB)
3. The other emission levels were very low against the limit.
4. Margin value = Emission Level – Limit value
5. " * ": Fundamental frequency.
6. " # ": The radiated frequency is out of the restricted band.

CHANNEL	TX Channel 140	DETECTOR FUNCTION	Peak (PK)
FREQUENCY RANGE	1GHz ~ 40GHz		Average (AV)

ANTENNA POLARITY & TEST DISTANCE: HORIZONTAL AT 3 M

NO.	FREQ. (MHz)	EMISSION LEVEL (dBuV/m)	LIMIT (dBuV/m)	MARGIN (dB)	ANTENNA HEIGHT (m)	TABLE ANGLE (Degree)	RAW VALUE (dBuV)	CORRECTION FACTOR (dB/m)
1	*5700.00	109.9 PK			1.81 H	360	105.4	4.5
2	*5700.00	99.1 AV			1.81 H	360	94.6	4.5
3	#5725.00	67.7 PK	74.0	-6.3	1.81 H	360	63.3	4.4
4	#5725.00	53.8 AV	54.0	-0.2	1.81 H	360	49.4	4.4
5	11400.00	48.9 PK	74.0	-25.1	2.01 H	52	35.3	13.6
6	11400.00	35.7 AV	54.0	-18.3	2.01 H	52	22.1	13.6
7	#17100.00	56.7 PK	74.0	-17.3	2.30 H	334	39.3	17.4
8	#17100.00	44.4 AV	54.0	-9.6	2.30 H	334	27.0	17.4

ANTENNA POLARITY & TEST DISTANCE: VERTICAL AT 3 M

NO.	FREQ. (MHz)	EMISSION LEVEL (dBuV/m)	LIMIT (dBuV/m)	MARGIN (dB)	ANTENNA HEIGHT (m)	TABLE ANGLE (Degree)	RAW VALUE (dBuV)	CORRECTION FACTOR (dB/m)
1	*5700.00	108.4 PK			3.50 V	306	103.9	4.5
2	*5700.00	97.3 AV			3.50 V	306	92.8	4.5
3	#5725.00	64.2 PK	74.0	-9.8	3.50 V	306	59.8	4.4
4	#5725.00	52.1 AV	54.0	-1.9	3.50 V	306	47.7	4.4
5	11400.00	46.8 PK	74.0	-27.2	1.73 V	162	33.2	13.6
6	11400.00	34.3 AV	54.0	-19.7	1.73 V	162	20.7	13.6
7	#17100.00	55.2 PK	74.0	-18.8	3.19 V	303	37.8	17.4
8	#17100.00	43.0 AV	54.0	-11.0	3.19 V	303	25.6	17.4

REMARKS:

1. Emission Level(dBuV/m) = Raw Value(dBuV) + Correction Factor(dB/m)
2. Correction Factor(dB/m) = Antenna Factor(dB/m) + Cable Factor(dB) – Pre-Amplifier Factor(dB)
3. The other emission levels were very low against the limit.
4. Margin value = Emission Level – Limit value
5. " * ": Fundamental frequency.
6. " # ": The radiated frequency is out of the restricted band.

CHANNEL	TX Channel 144	DETECTOR FUNCTION	Peak (PK)
FREQUENCY RANGE	1GHz ~ 40GHz		Average (AV)

ANTENNA POLARITY & TEST DISTANCE: HORIZONTAL AT 3 M

NO.	FREQ. (MHz)	EMISSION LEVEL (dBuV/m)	LIMIT (dBuV/m)	MARGIN (dB)	ANTENNA HEIGHT (m)	TABLE ANGLE (Degree)	RAW VALUE (dBuV)	CORRECTION FACTOR (dB/m)
1	#5470.00	57.1 PK	74.0	-16.9	1.84 H	360	53.1	4.0
2	#5470.00	44.8 AV	54.0	-9.2	1.84 H	360	40.8	4.0
3	*5720.00	109.2 PK			1.84 H	360	105.0	4.2
4	*5720.00	98.7 AV			1.84 H	360	94.5	4.2
5	#5850.00	67.9 PK	74.0	-6.1	1.84 H	360	63.3	4.6
6	#5850.00	53.7 AV	54.0	-0.3	1.84 H	360	49.1	4.6
7	11440.00	49.2 PK	74.0	-24.8	2.07 H	46	35.4	13.8
8	11440.00	36.1 AV	54.0	-17.9	2.07 H	46	22.3	13.8
9	#17160.00	57.0 PK	74.0	-17.0	2.28 H	324	40.6	16.4
10	#17160.00	44.6 AV	54.0	-9.4	2.28 H	324	28.2	16.4

ANTENNA POLARITY & TEST DISTANCE: VERTICAL AT 3 M

NO.	FREQ. (MHz)	EMISSION LEVEL (dBuV/m)	LIMIT (dBuV/m)	MARGIN (dB)	ANTENNA HEIGHT (m)	TABLE ANGLE (Degree)	RAW VALUE (dBuV)	CORRECTION FACTOR (dB/m)
1	#5470.00	55.6 PK	74.0	-18.4	3.50 V	303	51.6	4.0
2	#5470.00	43.3 AV	54.0	-10.7	3.50 V	303	39.3	4.0
3	*5720.00	108.1 PK			3.50 V	303	103.9	4.2
4	*5720.00	97.3 AV			3.50 V	303	93.1	4.2
5	#5850.00	64.1 PK	74.0	-9.9	3.50 V	303	59.5	4.6
6	#5850.00	51.9 AV	54.0	-2.1	3.50 V	303	47.3	4.6
7	11440.00	46.6 PK	74.0	-27.4	1.78 V	153	32.8	13.8
8	11440.00	34.3 AV	54.0	-19.7	1.78 V	153	20.5	13.8
9	#17160.00	54.7 PK	74.0	-19.3	3.21 V	294	38.3	16.4
10	#17160.00	42.7 AV	54.0	-11.3	3.21 V	294	26.3	16.4

REMARKS:

1. Emission Level(dBuV/m) = Raw Value(dBuV) + Correction Factor(dB/m)
2. Correction Factor(dB/m) = Antenna Factor(dB/m) + Cable Factor(dB) – Pre-Amplifier Factor(dB)
3. The other emission levels were very low against the limit.
4. Margin value = Emission Level – Limit value
5. " * ": Fundamental frequency.
6. " # ": The radiated frequency is out of the restricted band.

802.11ac (VHT20)

CHANNEL	TX Channel 52	DETECTOR FUNCTION	Peak (PK)
FREQUENCY RANGE	1GHz ~ 40GHz		Average (AV)

ANTENNA POLARITY & TEST DISTANCE: HORIZONTAL AT 3 M

NO.	FREQ. (MHz)	EMISSION LEVEL (dBuV/m)	LIMIT (dBuV/m)	MARGIN (dB)	ANTENNA HEIGHT (m)	TABLE ANGLE (Degree)	RAW VALUE (dBuV)	CORRECTION FACTOR (dB/m)
1	5150.00	51.3 PK	74.0	-22.7	1.54 H	351	47.6	3.7
2	5150.00	39.0 AV	54.0	-15.0	1.54 H	351	35.3	3.7
3	*5260.00	112.3 PK			1.54 H	351	108.3	4.0
4	*5260.00	101.9 AV			1.54 H	351	97.9	4.0
5	#10520.00	58.4 PK	74.0	-15.6	1.50 H	134	45.2	13.2
6	#10520.00	44.6 AV	54.0	-9.4	1.50 H	134	31.4	13.2
7	15780.00	54.9 PK	74.0	-19.1	3.11 H	314	41.3	13.6
8	15780.00	42.9 AV	54.0	-11.1	3.11 H	314	29.3	13.6

ANTENNA POLARITY & TEST DISTANCE: VERTICAL AT 3 M

NO.	FREQ. (MHz)	EMISSION LEVEL (dBuV/m)	LIMIT (dBuV/m)	MARGIN (dB)	ANTENNA HEIGHT (m)	TABLE ANGLE (Degree)	RAW VALUE (dBuV)	CORRECTION FACTOR (dB/m)
1	5150.00	52.9 PK	74.0	-21.1	2.78 V	356	49.2	3.7
2	5150.00	40.3 AV	54.0	-13.7	2.78 V	356	36.6	3.7
3	*5260.00	112.8 PK			2.78 V	356	108.8	4.0
4	*5260.00	103.1 AV			2.78 V	356	99.1	4.0
5	#10520.00	59.4 PK	74.0	-14.6	1.88 V	54	46.2	13.2
6	#10520.00	46.2 AV	54.0	-7.8	1.88 V	54	33.0	13.2
7	15780.00	55.4 PK	74.0	-18.6	2.42 V	360	41.8	13.6
8	15780.00	44.3 AV	54.0	-9.7	2.42 V	360	30.7	13.6

REMARKS:

- Emission Level(dBuV/m) = Raw Value(dBuV) + Correction Factor(dB/m)
- Correction Factor(dB/m) = Antenna Factor(dB/m) + Cable Factor(dB) – Pre-Amplifier Factor(dB)
- The other emission levels were very low against the limit.
- Margin value = Emission Level – Limit value
- " * ": Fundamental frequency.
- " # ": The radiated frequency is out of the restricted band.

CHANNEL	TX Channel 60	DETECTOR FUNCTION	Peak (PK)
FREQUENCY RANGE	1GHz ~ 40GHz		Average (AV)

ANTENNA POLARITY & TEST DISTANCE: HORIZONTAL AT 3 M

NO.	FREQ. (MHz)	EMISSION LEVEL (dBuV/m)	LIMIT (dBuV/m)	MARGIN (dB)	ANTENNA HEIGHT (m)	TABLE ANGLE (Degree)	RAW VALUE (dBuV)	CORRECTION FACTOR (dB/m)
1	*5300.00	112.4 PK			1.49 H	360	108.3	4.1
2	*5300.00	101.8 AV			1.49 H	360	97.7	4.1
3	10600.00	59.0 PK	74.0	-15.0	1.50 H	116	45.5	13.5
4	10600.00	45.2 AV	54.0	-8.8	1.50 H	116	31.7	13.5
5	15900.00	55.8 PK	74.0	-18.2	3.16 H	308	42.9	12.9
6	15900.00	43.3 AV	54.0	-10.7	3.16 H	308	30.4	12.9

ANTENNA POLARITY & TEST DISTANCE: VERTICAL AT 3 M

NO.	FREQ. (MHz)	EMISSION LEVEL (dBuV/m)	LIMIT (dBuV/m)	MARGIN (dB)	ANTENNA HEIGHT (m)	TABLE ANGLE (Degree)	RAW VALUE (dBuV)	CORRECTION FACTOR (dB/m)
1	*5300.00	112.9 PK			2.70 V	340	108.8	4.1
2	*5300.00	103.0 AV			2.70 V	340	98.9	4.1
3	10600.00	60.0 PK	74.0	-14.0	1.86 V	46	46.5	13.5
4	10600.00	46.7 AV	54.0	-7.3	1.86 V	46	33.2	13.5
5	15900.00	55.9 PK	74.0	-18.1	2.43 V	360	43.0	12.9
6	15900.00	44.8 AV	54.0	-9.2	2.43 V	360	31.9	12.9

REMARKS:

1. Emission Level(dBuV/m) = Raw Value(dBuV) + Correction Factor(dB/m)
2. Correction Factor(dB/m) = Antenna Factor(dB/m) + Cable Factor(dB) – Pre-Amplifier Factor(dB)
3. The other emission levels were very low against the limit.
4. Margin value = Emission Level – Limit value
5. " * ": Fundamental frequency.

CHANNEL	TX Channel 64	DETECTOR FUNCTION	Peak (PK)
FREQUENCY RANGE	1GHz ~ 40GHz		Average (AV)

ANTENNA POLARITY & TEST DISTANCE: HORIZONTAL AT 3 M

NO.	FREQ. (MHz)	EMISSION LEVEL (dBuV/m)	LIMIT (dBuV/m)	MARGIN (dB)	ANTENNA HEIGHT (m)	TABLE ANGLE (Degree)	RAW VALUE (dBuV)	CORRECTION FACTOR (dB/m)
1	*5320.00	108.7 PK			1.51 H	343	104.6	4.1
2	*5320.00	98.1 AV			1.51 H	343	94.0	4.1
3	5350.00	71.5 PK	74.0	-2.5	1.51 H	343	67.4	4.1
4	5350.00	52.4 AV	54.0	-1.6	1.51 H	343	48.3	4.1
5	10640.00	58.4 PK	74.0	-15.6	1.51 H	137	44.9	13.5
6	10640.00	45.0 AV	54.0	-9.0	1.51 H	137	31.5	13.5
7	15960.00	55.8 PK	74.0	-18.2	3.16 H	290	42.9	12.9
8	15960.00	43.5 AV	54.0	-10.5	3.16 H	290	30.6	12.9

ANTENNA POLARITY & TEST DISTANCE: VERTICAL AT 3 M

NO.	FREQ. (MHz)	EMISSION LEVEL (dBuV/m)	LIMIT (dBuV/m)	MARGIN (dB)	ANTENNA HEIGHT (m)	TABLE ANGLE (Degree)	RAW VALUE (dBuV)	CORRECTION FACTOR (dB/m)
1	*5320.00	109.2 PK			2.80 V	349	105.1	4.1
2	*5320.00	99.3 AV			2.80 V	349	95.2	4.1
3	5350.00	73.1 PK	74.0	-0.9	2.80 V	349	69.0	4.1
4	5350.00	53.7 AV	54.0	-0.3	2.80 V	349	49.6	4.1
5	10640.00	60.3 PK	74.0	-13.7	1.85 V	56	46.8	13.5
6	10640.00	46.9 AV	54.0	-7.1	1.85 V	56	33.4	13.5
7	15960.00	55.1 PK	74.0	-18.9	2.46 V	360	42.2	12.9
8	15960.00	44.4 AV	54.0	-9.6	2.46 V	360	31.5	12.9

REMARKS:

1. Emission Level(dBuV/m) = Raw Value(dBuV) + Correction Factor(dB/m)
2. Correction Factor(dB/m) = Antenna Factor(dB/m) + Cable Factor(dB) – Pre-Amplifier Factor(dB)
3. The other emission levels were very low against the limit.
4. Margin value = Emission Level – Limit value
5. " * ": Fundamental frequency.

CHANNEL	TX Channel 100	DETECTOR FUNCTION	Peak (PK)
FREQUENCY RANGE	1GHz ~ 40GHz		Average (AV)

ANTENNA POLARITY & TEST DISTANCE: HORIZONTAL AT 3 M

NO.	FREQ. (MHz)	EMISSION LEVEL (dBuV/m)	LIMIT (dBuV/m)	MARGIN (dB)	ANTENNA HEIGHT (m)	TABLE ANGLE (Degree)	RAW VALUE (dBuV)	CORRECTION FACTOR (dB/m)
1	#5470.00	71.6 PK	74.0	-2.4	1.84 H	360	67.4	4.2
2	#5470.00	53.9 AV	54.0	-0.1	1.84 H	360	49.7	4.2
3	*5500.00	111.8 PK			1.84 H	360	107.6	4.2
4	*5500.00	101.2 AV			1.84 H	360	97.0	4.2
5	11000.00	48.8 PK	74.0	-25.2	1.88 H	42	34.7	14.1
6	11000.00	35.9 AV	54.0	-18.1	1.88 H	42	21.8	14.1
7	#16500.00	55.6 PK	74.0	-18.4	2.31 H	358	41.1	14.5
8	#16500.00	43.9 AV	54.0	-10.1	2.31 H	358	29.4	14.5

ANTENNA POLARITY & TEST DISTANCE: VERTICAL AT 3 M

NO.	FREQ. (MHz)	EMISSION LEVEL (dBuV/m)	LIMIT (dBuV/m)	MARGIN (dB)	ANTENNA HEIGHT (m)	TABLE ANGLE (Degree)	RAW VALUE (dBuV)	CORRECTION FACTOR (dB/m)
1	#5470.00	68.0 PK	74.0	-6.0	3.54 V	304	63.8	4.2
2	#5470.00	52.5 AV	54.0	-1.5	3.54 V	304	48.3	4.2
3	*5500.00	110.2 PK			3.54 V	304	106.0	4.2
4	*5500.00	99.2 AV			3.54 V	304	95.0	4.2
5	11000.00	46.5 PK	74.0	-27.5	1.71 V	132	32.4	14.1
6	11000.00	34.2 AV	54.0	-19.8	1.71 V	132	20.1	14.1
7	#16500.00	55.9 PK	74.0	-18.1	3.06 V	322	41.4	14.5
8	#16500.00	43.4 AV	54.0	-10.6	3.06 V	322	28.9	14.5

REMARKS:

1. Emission Level(dBuV/m) = Raw Value(dBuV) + Correction Factor(dB/m)
2. Correction Factor(dB/m) = Antenna Factor(dB/m) + Cable Factor(dB) – Pre-Amplifier Factor(dB)
3. The other emission levels were very low against the limit.
4. Margin value = Emission Level – Limit value
5. " * ": Fundamental frequency.
6. " # ": The radiated frequency is out of the restricted band.

CHANNEL	TX Channel 116	DETECTOR FUNCTION	Peak (PK)
FREQUENCY RANGE	1GHz ~ 40GHz		Average (AV)

ANTENNA POLARITY & TEST DISTANCE: HORIZONTAL AT 3 M

NO.	FREQ. (MHz)	EMISSION LEVEL (dBuV/m)	LIMIT (dBuV/m)	MARGIN (dB)	ANTENNA HEIGHT (m)	TABLE ANGLE (Degree)	RAW VALUE (dBuV)	CORRECTION FACTOR (dB/m)
1	*5580.00	114.8 PK			1.87 H	360	110.6	4.2
2	*5580.00	104.4 AV			1.87 H	360	100.2	4.2
3	#5820.00	58.0 PK	74.0	-16.0	1.87 H	360	53.6	4.4
4	#5820.00	48.9 AV	54.0	-5.1	1.87 H	360	44.5	4.4
5	11160.00	48.9 PK	74.0	-25.1	1.93 H	33	35.2	13.7
6	11160.00	36.1 AV	54.0	-17.9	1.93 H	33	22.4	13.7
7	#16740.00	56.5 PK	74.0	-17.5	2.28 H	356	40.8	15.7
8	#16740.00	44.4 AV	54.0	-9.6	2.28 H	356	28.7	15.7

ANTENNA POLARITY & TEST DISTANCE: VERTICAL AT 3 M

NO.	FREQ. (MHz)	EMISSION LEVEL (dBuV/m)	LIMIT (dBuV/m)	MARGIN (dB)	ANTENNA HEIGHT (m)	TABLE ANGLE (Degree)	RAW VALUE (dBuV)	CORRECTION FACTOR (dB/m)
1	*5580.00	112.7 PK			3.56 V	306	108.5	4.2
2	*5580.00	102.0 AV			3.56 V	306	97.8	4.2
3	#5820.00	53.8 PK	74.0	-20.2	3.56 V	306	49.4	4.4
4	#5820.00	47.0 AV	54.0	-7.0	3.56 V	306	42.6	4.4
5	11160.00	46.0 PK	74.0	-28.0	1.69 V	116	32.3	13.7
6	11160.00	33.8 AV	54.0	-20.2	1.69 V	116	20.1	13.7
7	#16740.00	56.3 PK	74.0	-17.7	3.05 V	295	40.6	15.7
8	#16740.00	43.9 AV	54.0	-10.1	3.05 V	295	28.2	15.7

REMARKS:

1. Emission Level(dBuV/m) = Raw Value(dBuV) + Correction Factor(dB/m)
2. Correction Factor(dB/m) = Antenna Factor(dB/m) + Cable Factor(dB) – Pre-Amplifier Factor(dB)
3. The other emission levels were very low against the limit.
4. Margin value = Emission Level – Limit value
5. " * ": Fundamental frequency.
6. " # ": The radiated frequency is out of the restricted band.

CHANNEL	TX Channel 140	DETECTOR FUNCTION	Peak (PK)
FREQUENCY RANGE	1GHz ~ 40GHz		Average (AV)

ANTENNA POLARITY & TEST DISTANCE: HORIZONTAL AT 3 M

NO.	FREQ. (MHz)	EMISSION LEVEL (dBuV/m)	LIMIT (dBuV/m)	MARGIN (dB)	ANTENNA HEIGHT (m)	TABLE ANGLE (Degree)	RAW VALUE (dBuV)	CORRECTION FACTOR (dB/m)
1	*5700.00	110.0 PK			1.69 H	360	105.5	4.5
2	*5700.00	99.1 AV			1.69 H	360	94.6	4.5
3	#5725.00	67.8 PK	74.0	-6.2	1.69 H	360	63.4	4.4
4	#5725.00	53.9 AV	54.0	-0.1	1.69 H	360	49.5	4.4
5	11400.00	48.2 PK	74.0	-25.8	1.88 H	36	34.6	13.6
6	11400.00	35.0 AV	54.0	-19.0	1.88 H	36	21.4	13.6
7	#17100.00	57.0 PK	74.0	-17.0	2.40 H	356	39.6	17.4
8	#17100.00	44.6 AV	54.0	-9.4	2.40 H	356	27.2	17.4

ANTENNA POLARITY & TEST DISTANCE: VERTICAL AT 3 M

NO.	FREQ. (MHz)	EMISSION LEVEL (dBuV/m)	LIMIT (dBuV/m)	MARGIN (dB)	ANTENNA HEIGHT (m)	TABLE ANGLE (Degree)	RAW VALUE (dBuV)	CORRECTION FACTOR (dB/m)
1	*5700.00	108.8 PK			3.51 V	343	104.3	4.5
2	*5700.00	97.4 AV			3.51 V	343	92.9	4.5
3	#5725.00	64.6 PK	74.0	-9.4	3.51 V	343	60.2	4.4
4	#5725.00	52.3 AV	54.0	-1.7	3.51 V	343	47.9	4.4
5	11400.00	45.5 PK	74.0	-28.5	1.69 V	117	31.9	13.6
6	11400.00	33.3 AV	54.0	-20.7	1.69 V	117	19.7	13.6
7	#17100.00	56.1 PK	74.0	-17.9	3.11 V	321	38.7	17.4
8	#17100.00	43.7 AV	54.0	-10.3	3.11 V	321	26.3	17.4

REMARKS:

1. Emission Level(dBuV/m) = Raw Value(dBuV) + Correction Factor(dB/m)
2. Correction Factor(dB/m) = Antenna Factor(dB/m) + Cable Factor(dB) – Pre-Amplifier Factor(dB)
3. The other emission levels were very low against the limit.
4. Margin value = Emission Level – Limit value
5. " * ": Fundamental frequency.
6. " # ": The radiated frequency is out of the restricted band.

CHANNEL	TX Channel 144	DETECTOR FUNCTION	Peak (PK)
FREQUENCY RANGE	1GHz ~ 40GHz		Average (AV)

ANTENNA POLARITY & TEST DISTANCE: HORIZONTAL AT 3 M

NO.	FREQ. (MHz)	EMISSION LEVEL (dBuV/m)	LIMIT (dBuV/m)	MARGIN (dB)	ANTENNA HEIGHT (m)	TABLE ANGLE (Degree)	RAW VALUE (dBuV)	CORRECTION FACTOR (dB/m)
1	#5470.00	56.5 PK	74.0	-17.5	1.70 H	360	52.5	4.0
2	#5470.00	44.4 AV	54.0	-9.6	1.70 H	360	40.4	4.0
3	*5720.00	109.8 PK			1.70 H	360	105.6	4.2
4	*5720.00	98.9 AV			1.70 H	360	94.7	4.2
5	#5850.00	67.8 PK	74.0	-6.2	1.70 H	360	63.2	4.6
6	#5850.00	53.8 AV	54.0	-0.2	1.70 H	360	49.2	4.6
7	11440.00	48.6 PK	74.0	-25.4	1.94 H	30	34.8	13.8
8	11440.00	35.4 AV	54.0	-18.6	1.94 H	30	21.6	13.8
9	#17160.00	56.8 PK	74.0	-17.2	2.40 H	342	40.4	16.4
10	#17160.00	44.3 AV	54.0	-9.7	2.40 H	342	27.9	16.4

ANTENNA POLARITY & TEST DISTANCE: VERTICAL AT 3 M

NO.	FREQ. (MHz)	EMISSION LEVEL (dBuV/m)	LIMIT (dBuV/m)	MARGIN (dB)	ANTENNA HEIGHT (m)	TABLE ANGLE (Degree)	RAW VALUE (dBuV)	CORRECTION FACTOR (dB/m)
1	#5470.00	55.3 PK	74.0	-18.7	3.52 V	346	51.3	4.0
2	#5470.00	43.3 AV	54.0	-10.7	3.52 V	346	39.3	4.0
3	*5720.00	108.1 PK			3.52 V	346	103.9	4.2
4	*5720.00	97.0 AV			3.52 V	346	92.8	4.2
5	#5850.00	63.7 PK	74.0	-10.3	3.52 V	346	59.1	4.6
6	#5850.00	51.7 AV	54.0	-2.3	3.52 V	346	47.1	4.6
7	11440.00	45.5 PK	74.0	-28.5	1.74 V	115	31.7	13.8
8	11440.00	33.3 AV	54.0	-20.7	1.74 V	115	19.5	13.8
9	#17160.00	56.1 PK	74.0	-17.9	3.11 V	333	39.7	16.4
10	#17160.00	43.9 AV	54.0	-10.1	3.11 V	333	27.5	16.4

REMARKS:

1. Emission Level(dBuV/m) = Raw Value(dBuV) + Correction Factor(dB/m)
2. Correction Factor(dB/m) = Antenna Factor(dB/m) + Cable Factor(dB) – Pre-Amplifier Factor(dB)
3. The other emission levels were very low against the limit.
4. Margin value = Emission Level – Limit value
5. " * ": Fundamental frequency.
6. " # ": The radiated frequency is out of the restricted band.

802.11ac (VHT40)

CHANNEL	TX Channel 54	DETECTOR FUNCTION	Peak (PK)
FREQUENCY RANGE	1GHz ~ 40GHz		Average (AV)

ANTENNA POLARITY & TEST DISTANCE: HORIZONTAL AT 3 M

NO.	FREQ. (MHz)	EMISSION LEVEL (dBuV/m)	LIMIT (dBuV/m)	MARGIN (dB)	ANTENNA HEIGHT (m)	TABLE ANGLE (Degree)	RAW VALUE (dBuV)	CORRECTION FACTOR (dB/m)
1	5150.00	51.4 PK	74.0	-22.6	1.53 H	346	47.7	3.7
2	5150.00	39.0 AV	54.0	-15.0	1.53 H	346	35.3	3.7
3	*5270.00	110.8 PK			1.53 H	346	106.8	4.0
4	*5270.00	98.8 AV			1.53 H	346	94.8	4.0
5	#10540.00	58.3 PK	74.0	-15.7	1.48 H	124	45.0	13.3
6	#10540.00	44.7 AV	54.0	-9.3	1.48 H	124	31.4	13.3
7	15810.00	55.4 PK	74.0	-18.6	3.16 H	303	42.0	13.4
8	15810.00	42.9 AV	54.0	-11.1	3.16 H	303	29.5	13.4

ANTENNA POLARITY & TEST DISTANCE: VERTICAL AT 3 M

NO.	FREQ. (MHz)	EMISSION LEVEL (dBuV/m)	LIMIT (dBuV/m)	MARGIN (dB)	ANTENNA HEIGHT (m)	TABLE ANGLE (Degree)	RAW VALUE (dBuV)	CORRECTION FACTOR (dB/m)
1	5150.00	53.0 PK	74.0	-21.0	1.41 V	337	49.3	3.7
2	5150.00	40.3 AV	54.0	-13.7	1.41 V	337	36.6	3.7
3	*5270.00	111.8 PK			1.41 V	337	107.8	4.0
4	*5270.00	99.9 AV			1.41 V	337	95.9	4.0
5	#10540.00	59.8 PK	74.0	-14.2	1.82 V	28	46.5	13.3
6	#10540.00	46.7 AV	54.0	-7.3	1.82 V	28	33.4	13.3
7	15810.00	55.2 PK	74.0	-18.8	2.37 V	360	41.8	13.4
8	15810.00	44.4 AV	54.0	-9.6	2.37 V	360	31.0	13.4

REMARKS:

- Emission Level(dBuV/m) = Raw Value(dBuV) + Correction Factor(dB/m)
- Correction Factor(dB/m) = Antenna Factor(dB/m) + Cable Factor(dB) – Pre-Amplifier Factor(dB)
- The other emission levels were very low against the limit.
- Margin value = Emission Level – Limit value
- " * ": Fundamental frequency.
- " # ": The radiated frequency is out of the restricted band.

CHANNEL	TX Channel 62	DETECTOR FUNCTION	Peak (PK)
FREQUENCY RANGE	1GHz ~ 40GHz		Average (AV)

ANTENNA POLARITY & TEST DISTANCE: HORIZONTAL AT 3 M

NO.	FREQ. (MHz)	EMISSION LEVEL (dBuV/m)	LIMIT (dBuV/m)	MARGIN (dB)	ANTENNA HEIGHT (m)	TABLE ANGLE (Degree)	RAW VALUE (dBuV)	CORRECTION FACTOR (dB/m)
1	*5310.00	103.3 PK			1.38 H	356	99.2	4.1
2	*5310.00	91.3 AV			1.38 H	356	87.2	4.1
3	5350.00	70.1 PK	74.0	-3.9	1.38 H	356	66.0	4.1
4	5350.00	52.6 AV	54.0	-1.4	1.38 H	356	48.5	4.1
5	10620.00	58.2 PK	74.0	-15.8	1.50 H	136	44.7	13.5
6	10620.00	44.5 AV	54.0	-9.5	1.50 H	136	31.0	13.5
7	15930.00	55.1 PK	74.0	-18.9	3.12 H	316	42.3	12.8
8	15930.00	42.9 AV	54.0	-11.1	3.12 H	316	30.1	12.8

ANTENNA POLARITY & TEST DISTANCE: VERTICAL AT 3 M

NO.	FREQ. (MHz)	EMISSION LEVEL (dBuV/m)	LIMIT (dBuV/m)	MARGIN (dB)	ANTENNA HEIGHT (m)	TABLE ANGLE (Degree)	RAW VALUE (dBuV)	CORRECTION FACTOR (dB/m)
1	*5310.00	104.3 PK			1.36 V	345	100.2	4.1
2	*5310.00	92.4 AV			1.36 V	345	88.3	4.1
3	5350.00	71.7 PK	74.0	-2.3	1.36 V	345	67.6	4.1
4	5350.00	53.9 AV	54.0	-0.1	1.36 V	345	49.8	4.1
5	10620.00	59.4 PK	74.0	-14.6	1.87 V	32	45.9	13.5
6	10620.00	46.6 AV	54.0	-7.4	1.87 V	32	33.1	13.5
7	15930.00	55.0 PK	74.0	-19.0	2.36 V	360	42.2	12.8
8	15930.00	44.3 AV	54.0	-9.7	2.36 V	360	31.5	12.8

REMARKS:

1. Emission Level(dBuV/m) = Raw Value(dBuV) + Correction Factor(dB/m)
2. Correction Factor(dB/m) = Antenna Factor(dB/m) + Cable Factor(dB) – Pre-Amplifier Factor(dB)
3. The other emission levels were very low against the limit.
4. Margin value = Emission Level – Limit value
5. " * ": Fundamental frequency.

CHANNEL	TX Channel 102	DETECTOR FUNCTION	Peak (PK)
FREQUENCY RANGE	1GHz ~ 40GHz		Average (AV)

ANTENNA POLARITY & TEST DISTANCE: HORIZONTAL AT 3 M

NO.	FREQ. (MHz)	EMISSION LEVEL (dBuV/m)	LIMIT (dBuV/m)	MARGIN (dB)	ANTENNA HEIGHT (m)	TABLE ANGLE (Degree)	RAW VALUE (dBuV)	CORRECTION FACTOR (dB/m)
1	#5470.00	73.3 PK	74.0	-0.7	1.85 H	342	69.1	4.2
2	#5470.00	53.8 AV	54.0	-0.2	1.85 H	342	49.6	4.2
3	*5510.00	105.6 PK			1.85 H	342	101.4	4.2
4	*5510.00	96.5 AV			1.85 H	342	92.3	4.2
5	11020.00	48.6 PK	74.0	-25.4	1.91 H	58	34.6	14.0
6	11020.00	35.6 AV	54.0	-18.4	1.91 H	58	21.6	14.0
7	#16530.00	56.9 PK	74.0	-17.1	2.36 H	360	42.0	14.9
8	#16530.00	44.8 AV	54.0	-9.2	2.36 H	360	29.9	14.9

ANTENNA POLARITY & TEST DISTANCE: VERTICAL AT 3 M

NO.	FREQ. (MHz)	EMISSION LEVEL (dBuV/m)	LIMIT (dBuV/m)	MARGIN (dB)	ANTENNA HEIGHT (m)	TABLE ANGLE (Degree)	RAW VALUE (dBuV)	CORRECTION FACTOR (dB/m)
1	#5470.00	68.9 PK	74.0	-5.1	3.52 V	306	64.7	4.2
2	#5470.00	52.1 AV	54.0	-1.9	3.52 V	306	47.9	4.2
3	*5510.00	104.3 PK			3.52 V	306	100.1	4.2
4	*5510.00	94.8 AV			3.52 V	306	90.6	4.2
5	11020.00	45.9 PK	74.0	-28.1	1.71 V	157	31.9	14.0
6	11020.00	33.6 AV	54.0	-20.4	1.71 V	157	19.6	14.0
7	#16530.00	56.2 PK	74.0	-17.8	3.11 V	306	41.3	14.9
8	#16530.00	43.7 AV	54.0	-10.3	3.11 V	306	28.8	14.9

REMARKS:

1. Emission Level(dBuV/m) = Raw Value(dBuV) + Correction Factor(dB/m)
2. Correction Factor(dB/m) = Antenna Factor(dB/m) + Cable Factor(dB) – Pre-Amplifier Factor(dB)
3. The other emission levels were very low against the limit.
4. Margin value = Emission Level – Limit value
5. " * ": Fundamental frequency.
6. " # ": The radiated frequency is out of the restricted band.

CHANNEL	TX Channel 110	DETECTOR FUNCTION	Peak (PK)
FREQUENCY RANGE	1GHz ~ 40GHz		Average (AV)

ANTENNA POLARITY & TEST DISTANCE: HORIZONTAL AT 3 M

NO.	FREQ. (MHz)	EMISSION LEVEL (dBuV/m)	LIMIT (dBuV/m)	MARGIN (dB)	ANTENNA HEIGHT (m)	TABLE ANGLE (Degree)	RAW VALUE (dBuV)	CORRECTION FACTOR (dB/m)
1	#5470.00	69.6 PK	74.0	-4.4	1.73 H	360	65.4	4.2
2	#5470.00	53.9 AV	54.0	-0.1	1.73 H	360	49.7	4.2
3	*5550.00	111.1 PK			1.73 H	360	106.9	4.2
4	*5550.00	101.6 AV			1.73 H	360	97.4	4.2
5	11100.00	48.7 PK	74.0	-25.3	2.01 H	61	34.9	13.8
6	11100.00	36.0 AV	54.0	-18.0	2.01 H	61	22.2	13.8
7	#16650.00	56.5 PK	74.0	-17.5	2.26 H	360	40.9	15.6
8	#16650.00	44.2 AV	54.0	-9.8	2.26 H	360	28.6	15.6

ANTENNA POLARITY & TEST DISTANCE: VERTICAL AT 3 M

NO.	FREQ. (MHz)	EMISSION LEVEL (dBuV/m)	LIMIT (dBuV/m)	MARGIN (dB)	ANTENNA HEIGHT (m)	TABLE ANGLE (Degree)	RAW VALUE (dBuV)	CORRECTION FACTOR (dB/m)
1	#5470.00	65.2 PK	74.0	-8.8	3.53 V	340	61.0	4.2
2	#5470.00	51.9 AV	54.0	-2.1	3.53 V	340	47.7	4.2
3	*5550.00	110.3 PK			3.53 V	340	106.1	4.2
4	*5550.00	100.5 AV			3.53 V	340	96.3	4.2
5	11100.00	46.2 PK	74.0	-27.8	1.72 V	116	32.4	13.8
6	11100.00	33.6 AV	54.0	-20.4	1.72 V	116	19.8	13.8
7	#16650.00	55.8 PK	74.0	-18.2	3.09 V	315	40.2	15.6
8	#16650.00	43.2 AV	54.0	-10.8	3.09 V	315	27.6	15.6

REMARKS:

1. Emission Level(dBuV/m) = Raw Value(dBuV) + Correction Factor(dB/m)
2. Correction Factor(dB/m) = Antenna Factor(dB/m) + Cable Factor(dB) – Pre-Amplifier Factor(dB)
3. The other emission levels were very low against the limit.
4. Margin value = Emission Level – Limit value
5. " * ": Fundamental frequency.
6. " # ": The radiated frequency is out of the restricted band.

CHANNEL	TX Channel 134	DETECTOR FUNCTION	Peak (PK)
FREQUENCY RANGE	1GHz ~ 40GHz		Average (AV)

ANTENNA POLARITY & TEST DISTANCE: HORIZONTAL AT 3 M

NO.	FREQ. (MHz)	EMISSION LEVEL (dBuV/m)	LIMIT (dBuV/m)	MARGIN (dB)	ANTENNA HEIGHT (m)	TABLE ANGLE (Degree)	RAW VALUE (dBuV)	CORRECTION FACTOR (dB/m)
1	*5670.00	107.1 PK			1.78 H	338	102.8	4.3
2	*5670.00	97.6 AV			1.78 H	338	93.3	4.3
3	#5725.00	68.0 PK	74.0	-6.0	1.78 H	338	63.6	4.4
4	#5725.00	53.7 AV	54.0	-0.3	1.78 H	338	49.3	4.4
5	11340.00	48.9 PK	74.0	-25.1	1.96 H	29	35.3	13.6
6	11340.00	35.4 AV	54.0	-18.6	1.96 H	29	21.8	13.6
7	#17010.00	55.9 PK	74.0	-18.1	2.24 H	336	38.8	17.1
8	#17010.00	43.9 AV	54.0	-10.1	2.24 H	336	26.8	17.1

ANTENNA POLARITY & TEST DISTANCE: VERTICAL AT 3 M

NO.	FREQ. (MHz)	EMISSION LEVEL (dBuV/m)	LIMIT (dBuV/m)	MARGIN (dB)	ANTENNA HEIGHT (m)	TABLE ANGLE (Degree)	RAW VALUE (dBuV)	CORRECTION FACTOR (dB/m)
1	*5670.00	106.4 PK			3.52 V	332	102.1	4.3
2	*5670.00	96.6 AV			3.52 V	332	92.3	4.3
3	#5725.00	64.4 PK	74.0	-9.6	3.52 V	332	60.0	4.4
4	#5725.00	52.2 AV	54.0	-1.8	3.52 V	332	47.8	4.4
5	11340.00	46.0 PK	74.0	-28.0	1.67 V	142	32.4	13.6
6	11340.00	33.7 AV	54.0	-20.3	1.67 V	142	20.1	13.6
7	#17010.00	56.2 PK	74.0	-17.8	3.08 V	308	39.1	17.1
8	#17010.00	44.0 AV	54.0	-10.0	3.08 V	308	26.9	17.1

REMARKS:

1. Emission Level(dBuV/m) = Raw Value(dBuV) + Correction Factor(dB/m)
2. Correction Factor(dB/m) = Antenna Factor(dB/m) + Cable Factor(dB) – Pre-Amplifier Factor(dB)
3. The other emission levels were very low against the limit.
4. Margin value = Emission Level – Limit value
5. " * ": Fundamental frequency.
6. " # ": The radiated frequency is out of the restricted band.

CHANNEL	TX Channel 142	DETECTOR FUNCTION	Peak (PK)
FREQUENCY RANGE	1GHz ~ 40GHz		Average (AV)

ANTENNA POLARITY & TEST DISTANCE: HORIZONTAL AT 3 M

NO.	FREQ. (MHz)	EMISSION LEVEL (dBuV/m)	LIMIT (dBuV/m)	MARGIN (dB)	ANTENNA HEIGHT (m)	TABLE ANGLE (Degree)	RAW VALUE (dBuV)	CORRECTION FACTOR (dB/m)
1	#5470.00	56.6 PK	74.0	-17.4	1.81 H	325	52.6	4.0
2	#5470.00	44.5 AV	54.0	-9.5	1.81 H	325	40.5	4.0
3	*5710.00	107.2 PK			1.81 H	325	102.9	4.3
4	*5710.00	97.8 AV			1.81 H	325	93.5	4.3
5	#5850.00	67.8 PK	74.0	-6.2	1.81 H	325	63.2	4.6
6	#5850.00	53.6 AV	54.0	-0.4	1.81 H	325	49.0	4.6
7	11420.00	48.7 PK	74.0	-25.3	1.99 H	22	34.9	13.8
8	11420.00	35.2 AV	54.0	-18.8	1.99 H	22	21.4	13.8
9	#17130.00	55.8 PK	74.0	-18.2	2.23 H	330	39.3	16.5
10	#17130.00	43.6 AV	54.0	-10.4	2.23 H	330	27.1	16.5

ANTENNA POLARITY & TEST DISTANCE: VERTICAL AT 3 M

NO.	FREQ. (MHz)	EMISSION LEVEL (dBuV/m)	LIMIT (dBuV/m)	MARGIN (dB)	ANTENNA HEIGHT (m)	TABLE ANGLE (Degree)	RAW VALUE (dBuV)	CORRECTION FACTOR (dB/m)
1	#5470.00	55.5 PK	74.0	-18.5	3.55 V	341	51.5	4.0
2	#5470.00	43.1 AV	54.0	-10.9	3.55 V	341	39.1	4.0
3	*5710.00	106.8 PK			3.55 V	341	102.5	4.3
4	*5710.00	96.9 AV			3.55 V	341	92.6	4.3
5	#5850.00	63.8 PK	74.0	-10.2	3.55 V	341	59.2	4.6
6	#5850.00	51.7 AV	54.0	-2.3	3.55 V	341	47.1	4.6
7	11420.00	46.3 PK	74.0	-27.7	1.68 V	148	32.5	13.8
8	11420.00	33.7 AV	54.0	-20.3	1.68 V	148	19.9	13.8
9	#17130.00	55.8 PK	74.0	-18.2	3.04 V	295	39.3	16.5
10	#17130.00	43.8 AV	54.0	-10.2	3.04 V	295	27.3	16.5

REMARKS:

1. Emission Level(dBuV/m) = Raw Value(dBuV) + Correction Factor(dB/m)
2. Correction Factor(dB/m) = Antenna Factor(dB/m) + Cable Factor(dB) – Pre-Amplifier Factor(dB)
3. The other emission levels were very low against the limit.
4. Margin value = Emission Level – Limit value
5. " * ": Fundamental frequency.
6. " # ": The radiated frequency is out of the restricted band.

802.11ac (VHT80)

CHANNEL	TX Channel 58	DETECTOR FUNCTION	Peak (PK)
FREQUENCY RANGE	1GHz ~ 40GHz		Average (AV)

ANTENNA POLARITY & TEST DISTANCE: HORIZONTAL AT 3 M

NO.	FREQ. (MHz)	EMISSION LEVEL (dBuV/m)	LIMIT (dBuV/m)	MARGIN (dB)	ANTENNA HEIGHT (m)	TABLE ANGLE (Degree)	RAW VALUE (dBuV)	CORRECTION FACTOR (dB/m)
1	5150.00	51.5 PK	74.0	-22.5	1.45 H	335	47.8	3.7
2	5150.00	38.9 AV	54.0	-15.1	1.45 H	335	35.2	3.7
3	*5290.00	99.8 PK			1.45 H	335	95.7	4.1
4	*5290.00	90.5 AV			1.45 H	335	86.4	4.1
5	5350.00	69.8 PK	74.0	-4.2	1.45 H	335	65.7	4.1
6	5350.00	52.6 AV	54.0	-1.4	1.45 H	335	48.5	4.1
7	#10580.00	57.9 PK	74.0	-16.1	1.55 H	123	44.5	13.4
8	#10580.00	44.2 AV	54.0	-9.8	1.55 H	123	30.8	13.4
9	15870.00	55.7 PK	74.0	-18.3	3.06 H	313	42.7	13.0
10	15870.00	43.4 AV	54.0	-10.6	3.06 H	313	30.4	13.0

ANTENNA POLARITY & TEST DISTANCE: VERTICAL AT 3 M

NO.	FREQ. (MHz)	EMISSION LEVEL (dBuV/m)	LIMIT (dBuV/m)	MARGIN (dB)	ANTENNA HEIGHT (m)	TABLE ANGLE (Degree)	RAW VALUE (dBuV)	CORRECTION FACTOR (dB/m)
1	5150.00	53.1 PK	74.0	-20.9	1.50 V	360	49.4	3.7
2	5150.00	40.2 AV	54.0	-13.8	1.50 V	360	36.5	3.7
3	*5290.00	101.1 PK			1.50 V	360	97.0	4.1
4	*5290.00	91.7 AV			1.50 V	360	87.6	4.1
5	5350.00	71.4 PK	74.0	-2.6	1.50 V	360	67.3	4.1
6	5350.00	53.9 AV	54.0	-0.1	1.50 V	360	49.8	4.1
7	#10580.00	59.9 PK	74.0	-14.1	1.84 V	47	46.5	13.4
8	#10580.00	46.6 AV	54.0	-7.4	1.84 V	47	33.2	13.4
9	15870.00	55.7 PK	74.0	-18.3	2.41 V	356	42.7	13.0
10	15870.00	44.8 AV	54.0	-9.2	2.41 V	356	31.8	13.0

REMARKS:

- Emission Level(dBuV/m) = Raw Value(dBuV) + Correction Factor(dB/m)
- Correction Factor(dB/m) = Antenna Factor(dB/m) + Cable Factor(dB) – Pre-Amplifier Factor(dB)
- The other emission levels were very low against the limit.
- Margin value = Emission Level – Limit value
- " * ": Fundamental frequency.
- " # ": The radiated frequency is out of the restricted band.

CHANNEL	TX Channel 106	DETECTOR FUNCTION	Peak (PK)
FREQUENCY RANGE	1GHz ~ 40GHz		Average (AV)

ANTENNA POLARITY & TEST DISTANCE: HORIZONTAL AT 3 M

NO.	FREQ. (MHz)	EMISSION LEVEL (dBuV/m)	LIMIT (dBuV/m)	MARGIN (dB)	ANTENNA HEIGHT (m)	TABLE ANGLE (Degree)	RAW VALUE (dBuV)	CORRECTION FACTOR (dB/m)
1	#5470.00	72.4 PK	74.0	-1.6	1.96 H	341	68.2	4.2
2	#5470.00	53.9 AV	54.0	-0.1	1.96 H	341	49.7	4.2
3	*5530.00	102.5 PK			1.96 H	341	98.3	4.2
4	*5530.00	93.3 AV			1.96 H	341	89.1	4.2
5	#5725.00	51.3 PK	74.0	-22.7	1.96 H	341	46.9	4.4
6	#5725.00	40.4 AV	54.0	-13.6	1.96 H	341	36.0	4.4
7	11060.00	48.4 PK	74.0	-25.6	1.99 H	16	34.5	13.9
8	11060.00	35.1 AV	54.0	-18.9	1.99 H	16	21.2	13.9
9	#16590.00	57.6 PK	74.0	-16.4	2.35 H	347	42.0	15.6
10	#16590.00	45.0 AV	54.0	-9.0	2.35 H	347	29.4	15.6

ANTENNA POLARITY & TEST DISTANCE: VERTICAL AT 3 M

NO.	FREQ. (MHz)	EMISSION LEVEL (dBuV/m)	LIMIT (dBuV/m)	MARGIN (dB)	ANTENNA HEIGHT (m)	TABLE ANGLE (Degree)	RAW VALUE (dBuV)	CORRECTION FACTOR (dB/m)
1	#5470.00	68.4 PK	74.0	-5.6	3.52 V	340	64.2	4.2
2	#5470.00	51.6 AV	54.0	-2.4	3.52 V	340	47.4	4.2
3	*5530.00	100.6 PK			3.52 V	340	96.4	4.2
4	*5530.00	92.2 AV			3.52 V	340	88.0	4.2
5	#5725.00	46.9 PK	74.0	-27.1	3.52 V	340	42.5	4.4
6	#5725.00	37.9 AV	54.0	-16.1	3.52 V	340	33.5	4.4
7	11060.00	46.0 PK	74.0	-28.0	1.68 V	154	32.1	13.9
8	11060.00	33.2 AV	54.0	-20.8	1.68 V	154	19.3	13.9
9	#16590.00	56.4 PK	74.0	-17.6	3.15 V	290	40.8	15.6
10	#16590.00	43.6 AV	54.0	-10.4	3.15 V	290	28.0	15.6

REMARKS:

1. Emission Level(dBuV/m) = Raw Value(dBuV) + Correction Factor(dB/m)
2. Correction Factor(dB/m) = Antenna Factor(dB/m) + Cable Factor(dB) – Pre-Amplifier Factor(dB)
3. The other emission levels were very low against the limit.
4. Margin value = Emission Level – Limit value
5. " * ": Fundamental frequency.
6. " # ": The radiated frequency is out of the restricted band.

CHANNEL	TX Channel 122	DETECTOR FUNCTION	Peak (PK)
FREQUENCY RANGE	1GHz ~ 40GHz		Average (AV)

ANTENNA POLARITY & TEST DISTANCE: HORIZONTAL AT 3 M

NO.	FREQ. (MHz)	EMISSION LEVEL (dBuV/m)	LIMIT (dBuV/m)	MARGIN (dB)	ANTENNA HEIGHT (m)	TABLE ANGLE (Degree)	RAW VALUE (dBuV)	CORRECTION FACTOR (dB/m)
1	*5610.00	104.0 PK			1.94 H	360	99.6	4.4
2	*5610.00	94.5 AV			1.94 H	360	90.1	4.4
3	#5725.00	66.3 PK	74.0	-7.7	1.94 H	360	61.9	4.4
4	#5725.00	53.7 AV	54.0	-0.3	1.94 H	360	49.3	4.4
5	11220.00	48.2 PK	74.0	-25.8	2.03 H	26	34.5	13.7
6	11220.00	35.5 AV	54.0	-18.5	2.03 H	26	21.8	13.7
7	#16830.00	55.7 PK	74.0	-18.3	2.35 H	350	39.8	15.9
8	#16830.00	43.4 AV	54.0	-10.6	2.35 H	350	27.5	15.9

ANTENNA POLARITY & TEST DISTANCE: VERTICAL AT 3 M

NO.	FREQ. (MHz)	EMISSION LEVEL (dBuV/m)	LIMIT (dBuV/m)	MARGIN (dB)	ANTENNA HEIGHT (m)	TABLE ANGLE (Degree)	RAW VALUE (dBuV)	CORRECTION FACTOR (dB/m)
1	*5610.00	101.6 PK			3.48 V	304	97.2	4.4
2	*5610.00	92.8 AV			3.48 V	304	88.4	4.4
3	#5725.00	62.8 PK	74.0	-11.2	3.48 V	304	58.4	4.4
4	#5725.00	52.2 AV	54.0	-1.8	3.48 V	304	47.8	4.4
5	11220.00	46.2 PK	74.0	-27.8	1.70 V	138	32.5	13.7
6	11220.00	33.7 AV	54.0	-20.3	1.70 V	138	20.0	13.7
7	#16830.00	55.5 PK	74.0	-18.5	3.08 V	320	39.6	15.9
8	#16830.00	43.4 AV	54.0	-10.6	3.08 V	320	27.5	15.9

REMARKS:

1. Emission Level(dBuV/m) = Raw Value(dBuV) + Correction Factor(dB/m)
2. Correction Factor(dB/m) = Antenna Factor(dB/m) + Cable Factor(dB) – Pre-Amplifier Factor(dB)
3. The other emission levels were very low against the limit.
4. Margin value = Emission Level – Limit value
5. " * ": Fundamental frequency.
6. " # ": The radiated frequency is out of the restricted band.

CHANNEL	TX Channel 138	DETECTOR FUNCTION	Peak (PK)
FREQUENCY RANGE	1GHz ~ 40GHz		Average (AV)

ANTENNA POLARITY & TEST DISTANCE: HORIZONTAL AT 3 M

NO.	FREQ. (MHz)	EMISSION LEVEL (dBuV/m)	LIMIT (dBuV/m)	MARGIN (dB)	ANTENNA HEIGHT (m)	TABLE ANGLE (Degree)	RAW VALUE (dBuV)	CORRECTION FACTOR (dB/m)
1	#5470.00	56.8 PK	74.0	-17.2	1.98 H	360	52.8	4.0
2	#5470.00	44.5 AV	54.0	-9.5	1.98 H	360	40.5	4.0
3	*5690.00	104.1 PK			1.98 H	360	99.9	4.2
4	*5690.00	94.8 AV			1.98 H	360	90.6	4.2
5	#5850.00	68.2 PK	74.0	-5.8	1.98 H	360	63.6	4.6
6	#5850.00	53.8 AV	54.0	-0.2	1.98 H	360	49.2	4.6
7	11380.00	48.0 PK	74.0	-26.0	1.99 H	25	34.3	13.7
8	11380.00	35.1 AV	54.0	-18.9	1.99 H	25	21.4	13.7
9	#17070.00	55.8 PK	74.0	-18.2	2.33 H	337	39.2	16.6
10	#17070.00	43.5 AV	54.0	-10.5	2.33 H	337	26.9	16.6

ANTENNA POLARITY & TEST DISTANCE: VERTICAL AT 3 M

NO.	FREQ. (MHz)	EMISSION LEVEL (dBuV/m)	LIMIT (dBuV/m)	MARGIN (dB)	ANTENNA HEIGHT (m)	TABLE ANGLE (Degree)	RAW VALUE (dBuV)	CORRECTION FACTOR (dB/m)
1	#5470.00	54.9 PK	74.0	-19.1	3.44 V	303	50.9	4.0
2	#5470.00	42.6 AV	54.0	-11.4	3.44 V	303	38.6	4.0
3	*5690.00	101.6 PK			3.44 V	303	97.4	4.2
4	*5690.00	92.9 AV			3.44 V	303	88.7	4.2
5	#5850.00	64.0 PK	74.0	-10.0	3.44 V	303	59.4	4.6
6	#5850.00	51.7 AV	54.0	-2.3	3.44 V	303	47.1	4.6
7	11380.00	45.7 PK	74.0	-28.3	1.75 V	153	32.0	13.7
8	11380.00	33.4 AV	54.0	-20.6	1.75 V	153	19.7	13.7
9	#17070.00	55.2 PK	74.0	-18.8	3.05 V	317	38.6	16.6
10	#17070.00	43.2 AV	54.0	-10.8	3.05 V	317	26.6	16.6

REMARKS:

1. Emission Level(dBuV/m) = Raw Value(dBuV) + Correction Factor(dB/m)
2. Correction Factor(dB/m) = Antenna Factor(dB/m) + Cable Factor(dB) – Pre-Amplifier Factor(dB)
3. The other emission levels were very low against the limit.
4. Margin value = Emission Level – Limit value
5. " * ": Fundamental frequency.
6. " # ": The radiated frequency is out of the restricted band.

Below 1GHz Data:
802.11ac (VHT20)

CHANNEL	TX Channel 140	DETECTOR FUNCTION	Quasi-Peak (QP)
FREQUENCY RANGE	9kHz ~ 1GHz		

ANTENNA POLARITY & TEST DISTANCE: HORIZONTAL AT 3 M

NO.	FREQ. (MHz)	EMISSION LEVEL (dBuV/m)	LIMIT (dBuV/m)	MARGIN (dB)	ANTENNA HEIGHT (m)	TABLE ANGLE (Degree)	RAW VALUE (dBuV)	CORRECTION FACTOR (dB/m)
1	88.49	33.2 QP	43.5	-10.3	2.00 H	360	47.3	-14.1
2	114.44	32.1 QP	43.5	-11.4	3.00 H	251	42.8	-10.7
3	223.95	30.7 QP	46.0	-15.3	1.00 H	50	41.8	-11.1
4	346.83	35.3 QP	46.0	-10.7	1.00 H	300	41.8	-6.5
5	396.66	37.5 QP	46.0	-8.5	3.00 H	166	42.9	-5.4
6	470.23	35.1 QP	46.0	-10.9	3.00 H	115	38.7	-3.6

ANTENNA POLARITY & TEST DISTANCE: VERTICAL AT 3 M

NO.	FREQ. (MHz)	EMISSION LEVEL (dBuV/m)	LIMIT (dBuV/m)	MARGIN (dB)	ANTENNA HEIGHT (m)	TABLE ANGLE (Degree)	RAW VALUE (dBuV)	CORRECTION FACTOR (dB/m)
1	38.61	34.7 QP	40.0	-5.3	1.00 V	152	43.4	-8.7
2	114.75	34.5 QP	43.5	-9.0	1.00 V	6	45.2	-10.7
3	224.19	29.4 QP	46.0	-16.6	1.00 V	194	40.4	-11.0
4	345.95	40.3 QP	46.0	-5.7	2.00 V	360	46.8	-6.5
5	386.67	39.7 QP	46.0	-6.3	1.00 V	99	45.4	-5.7
6	484.78	35.7 QP	46.0	-10.3	1.00 V	43	39.1	-3.4

REMARKS:

1. Emission Level(dBuV/m) = Raw Value(dBuV) + Correction Factor(dB/m)
2. Correction Factor(dB/m) = Antenna Factor(dB/m) + Cable Factor(dB) – Pre-Amplifier Factor(dB)
3. The other emission levels were very low against the limit.
4. Margin value = Emission Level – Limit value

Omnidirectional

Above 1GHz Data:

802.11a

CHANNEL	TX Channel 52	DETECTOR FUNCTION	Peak (PK)
FREQUENCY RANGE	1GHz ~ 40GHz		Average (AV)

ANTENNA POLARITY & TEST DISTANCE: HORIZONTAL AT 3 M

NO.	FREQ. (MHz)	EMISSION LEVEL (dBuV/m)	LIMIT (dBuV/m)	MARGIN (dB)	ANTENNA HEIGHT (m)	TABLE ANGLE (Degree)	RAW VALUE (dBuV)	CORRECTION FACTOR (dB/m)
1	5150.00	52.7 PK	74.0	-21.3	2.78 H	353	49.0	3.7
2	5150.00	39.7 AV	54.0	-14.3	2.78 H	353	36.0	3.7
3	*5260.00	112.6 PK			2.78 H	353	108.6	4.0
4	*5260.00	102.6 AV			2.78 H	353	98.6	4.0
5	#10520.00	59.1 PK	74.0	-14.9	1.88 H	29	45.9	13.2
6	#10520.00	46.3 AV	54.0	-7.7	1.88 H	29	33.1	13.2
7	15780.00	54.9 PK	74.0	-19.1	2.48 H	358	41.3	13.6
8	15780.00	44.2 AV	54.0	-9.8	2.48 H	358	30.6	13.6

ANTENNA POLARITY & TEST DISTANCE: VERTICAL AT 3 M

NO.	FREQ. (MHz)	EMISSION LEVEL (dBuV/m)	LIMIT (dBuV/m)	MARGIN (dB)	ANTENNA HEIGHT (m)	TABLE ANGLE (Degree)	RAW VALUE (dBuV)	CORRECTION FACTOR (dB/m)
1	5150.00	51.2 PK	74.0	-22.8	1.51 V	360	47.5	3.7
2	5150.00	38.8 AV	54.0	-15.2	1.51 V	360	35.1	3.7
3	*5260.00	112.1 PK			1.51 V	360	108.1	4.0
4	*5260.00	101.2 AV			1.51 V	360	97.2	4.0
5	#10520.00	58.1 PK	74.0	-15.9	1.43 V	138	44.9	13.2
6	#10520.00	44.3 AV	54.0	-9.7	1.43 V	138	31.1	13.2
7	15780.00	54.5 PK	74.0	-19.5	3.09 V	285	40.9	13.6
8	15780.00	42.8 AV	54.0	-11.2	3.09 V	285	29.2	13.6

REMARKS:

1. Emission Level(dBuV/m) = Raw Value(dBuV) + Correction Factor(dB/m)
2. Correction Factor(dB/m) = Antenna Factor(dB/m) + Cable Factor(dB) – Pre-Amplifier Factor(dB)
3. The other emission levels were very low against the limit.
4. Margin value = Emission Level – Limit value
5. " * ": Fundamental frequency.
6. " # ": The radiated frequency is out of the restricted band.

CHANNEL	TX Channel 60	DETECTOR FUNCTION	Peak (PK)
FREQUENCY RANGE	1GHz ~ 40GHz		Average (AV)

ANTENNA POLARITY & TEST DISTANCE: HORIZONTAL AT 3 M

NO.	FREQ. (MHz)	EMISSION LEVEL (dBuV/m)	LIMIT (dBuV/m)	MARGIN (dB)	ANTENNA HEIGHT (m)	TABLE ANGLE (Degree)	RAW VALUE (dBuV)	CORRECTION FACTOR (dB/m)
1	5150.00	50.4 PK	74.0	-23.6	2.75 H	351	46.7	3.7
2	5150.00	37.4 AV	54.0	-16.6	2.75 H	351	33.7	3.7
3	*5300.00	112.1 PK			2.75 H	351	108.0	4.1
4	*5300.00	102.0 AV			2.75 H	351	97.9	4.1
5	5350.00	63.1 PK	74.0	-10.9	2.75 H	351	59.0	4.1
6	5350.00	43.0 AV	54.0	-11.0	2.75 H	351	38.9	4.1
7	10600.00	59.2 PK	74.0	-14.8	1.82 H	50	45.7	13.5
8	10600.00	46.6 AV	54.0	-7.4	1.82 H	50	33.1	13.5
9	15900.00	55.3 PK	74.0	-18.7	2.48 H	360	42.4	12.9
10	15900.00	44.4 AV	54.0	-9.6	2.48 H	360	31.5	12.9

ANTENNA POLARITY & TEST DISTANCE: VERTICAL AT 3 M

NO.	FREQ. (MHz)	EMISSION LEVEL (dBuV/m)	LIMIT (dBuV/m)	MARGIN (dB)	ANTENNA HEIGHT (m)	TABLE ANGLE (Degree)	RAW VALUE (dBuV)	CORRECTION FACTOR (dB/m)
1	5150.00	49.2 PK	74.0	-24.8	1.56 V	355	45.5	3.7
2	5150.00	36.2 AV	54.0	-17.8	1.56 V	355	32.5	3.7
3	*5300.00	111.6 PK			1.56 V	355	107.5	4.1
4	*5300.00	101.1 AV			1.56 V	355	97.0	4.1
5	5350.00	61.4 PK	74.0	-12.6	1.56 V	355	57.3	4.1
6	5350.00	41.6 AV	54.0	-12.4	1.56 V	355	37.5	4.1
7	10600.00	58.7 PK	74.0	-15.3	1.49 V	128	45.2	13.5
8	10600.00	45.2 AV	54.0	-8.8	1.49 V	128	31.7	13.5
9	15900.00	55.8 PK	74.0	-18.2	3.08 V	328	42.9	12.9
10	15900.00	43.6 AV	54.0	-10.4	3.08 V	328	30.7	12.9

REMARKS:

1. Emission Level(dBuV/m) = Raw Value(dBuV) + Correction Factor(dB/m)
2. Correction Factor(dB/m) = Antenna Factor(dB/m) + Cable Factor(dB) – Pre-Amplifier Factor(dB)
3. The other emission levels were very low against the limit.
4. Margin value = Emission Level – Limit value
5. " * ": Fundamental frequency.

CHANNEL	TX Channel 64	DETECTOR FUNCTION	Peak (PK)
FREQUENCY RANGE	1GHz ~ 40GHz		Average (AV)

ANTENNA POLARITY & TEST DISTANCE: HORIZONTAL AT 3 M

NO.	FREQ. (MHz)	EMISSION LEVEL (dBuV/m)	LIMIT (dBuV/m)	MARGIN (dB)	ANTENNA HEIGHT (m)	TABLE ANGLE (Degree)	RAW VALUE (dBuV)	CORRECTION FACTOR (dB/m)
1	*5320.00	109.0 PK			2.79 H	343	104.9	4.1
2	*5320.00	99.1 AV			2.79 H	343	95.0	4.1
3	5350.00	71.4 PK	74.0	-2.6	2.79 H	343	67.3	4.1
4	5350.00	53.8 AV	54.0	-0.2	2.79 H	343	49.7	4.1
5	10640.00	60.1 PK	74.0	-13.9	1.89 H	27	46.6	13.5
6	10640.00	46.7 AV	54.0	-7.3	1.89 H	27	33.2	13.5
7	15960.00	55.3 PK	74.0	-18.7	2.39 H	345	42.4	12.9
8	15960.00	44.2 AV	54.0	-9.8	2.39 H	345	31.3	12.9

ANTENNA POLARITY & TEST DISTANCE: VERTICAL AT 3 M

NO.	FREQ. (MHz)	EMISSION LEVEL (dBuV/m)	LIMIT (dBuV/m)	MARGIN (dB)	ANTENNA HEIGHT (m)	TABLE ANGLE (Degree)	RAW VALUE (dBuV)	CORRECTION FACTOR (dB/m)
1	*5320.00	108.8 PK			1.55 V	341	104.7	4.1
2	*5320.00	98.1 AV			1.55 V	341	94.0	4.1
3	5350.00	70.2 PK	74.0	-3.8	1.55 V	341	66.1	4.1
4	5350.00	52.9 AV	54.0	-1.1	1.55 V	341	48.8	4.1
5	10640.00	59.0 PK	74.0	-15.0	1.46 V	152	45.5	13.5
6	10640.00	45.2 AV	54.0	-8.8	1.46 V	152	31.7	13.5
7	15960.00	56.1 PK	74.0	-17.9	3.11 V	311	43.2	12.9
8	15960.00	43.7 AV	54.0	-10.3	3.11 V	311	30.8	12.9

REMARKS:

1. Emission Level(dBuV/m) = Raw Value(dBuV) + Correction Factor(dB/m)
2. Correction Factor(dB/m) = Antenna Factor(dB/m) + Cable Factor(dB) – Pre-Amplifier Factor(dB)
3. The other emission levels were very low against the limit.
4. Margin value = Emission Level – Limit value
5. " * ": Fundamental frequency.

CHANNEL	TX Channel 100	DETECTOR FUNCTION	Peak (PK)
FREQUENCY RANGE	1GHz ~ 40GHz		Average (AV)

ANTENNA POLARITY & TEST DISTANCE: HORIZONTAL AT 3 M

NO.	FREQ. (MHz)	EMISSION LEVEL (dBuV/m)	LIMIT (dBuV/m)	MARGIN (dB)	ANTENNA HEIGHT (m)	TABLE ANGLE (Degree)	RAW VALUE (dBuV)	CORRECTION FACTOR (dB/m)
1	#5470.00	69.1 PK	74.0	-4.9	3.54 H	317	64.9	4.2
2	#5470.00	52.2 AV	54.0	-1.8	3.54 H	317	48.0	4.2
3	*5500.00	109.8 PK			3.54 H	317	105.6	4.2
4	*5500.00	98.5 AV			3.54 H	317	94.3	4.2
5	11000.00	46.9 PK	74.0	-27.1	1.74 H	150	32.8	14.1
6	11000.00	34.7 AV	54.0	-19.3	1.74 H	150	20.6	14.1
7	#16500.00	56.6 PK	74.0	-17.4	3.09 H	309	42.1	14.5
8	#16500.00	43.8 AV	54.0	-10.2	3.09 H	309	29.3	14.5

ANTENNA POLARITY & TEST DISTANCE: VERTICAL AT 3 M

NO.	FREQ. (MHz)	EMISSION LEVEL (dBuV/m)	LIMIT (dBuV/m)	MARGIN (dB)	ANTENNA HEIGHT (m)	TABLE ANGLE (Degree)	RAW VALUE (dBuV)	CORRECTION FACTOR (dB/m)
1	#5470.00	72.5 PK	74.0	-1.5	1.92 V	360	68.3	4.2
2	#5470.00	53.9 AV	54.0	-0.1	1.92 V	360	49.7	4.2
3	*5500.00	110.0 PK			1.92 V	360	105.8	4.2
4	*5500.00	99.1 AV			1.92 V	360	94.9	4.2
5	11000.00	48.9 PK	74.0	-25.1	1.95 V	12	34.8	14.1
6	11000.00	35.8 AV	54.0	-18.2	1.95 V	12	21.7	14.1
7	#16500.00	57.5 PK	74.0	-16.5	2.19 V	324	43.0	14.5
8	#16500.00	44.5 AV	54.0	-9.5	2.19 V	324	30.0	14.5

REMARKS:

1. Emission Level(dBuV/m) = Raw Value(dBuV) + Correction Factor(dB/m)
2. Correction Factor(dB/m) = Antenna Factor(dB/m) + Cable Factor(dB) – Pre-Amplifier Factor(dB)
3. The other emission levels were very low against the limit.
4. Margin value = Emission Level – Limit value
5. " * ": Fundamental frequency.
6. " # ": The radiated frequency is out of the restricted band.

CHANNEL	TX Channel 116	DETECTOR FUNCTION	Peak (PK)
FREQUENCY RANGE	1GHz ~ 40GHz		Average (AV)

ANTENNA POLARITY & TEST DISTANCE: HORIZONTAL AT 3 M

NO.	FREQ. (MHz)	EMISSION LEVEL (dBuV/m)	LIMIT (dBuV/m)	MARGIN (dB)	ANTENNA HEIGHT (m)	TABLE ANGLE (Degree)	RAW VALUE (dBuV)	CORRECTION FACTOR (dB/m)
1	*5580.00	109.2 PK			3.50 H	301	105.0	4.2
2	*5580.00	99.6 AV			3.50 H	301	95.4	4.2
3	11160.00	46.0 PK	74.0	-28.0	1.57 H	142	32.3	13.7
4	11160.00	34.1 AV	54.0	-19.9	1.57 H	142	20.4	13.7
5	#16740.00	55.8 PK	74.0	-18.2	3.02 H	307	40.1	15.7
6	#16740.00	43.5 AV	54.0	-10.5	3.02 H	307	27.8	15.7

ANTENNA POLARITY & TEST DISTANCE: VERTICAL AT 3 M

NO.	FREQ. (MHz)	EMISSION LEVEL (dBuV/m)	LIMIT (dBuV/m)	MARGIN (dB)	ANTENNA HEIGHT (m)	TABLE ANGLE (Degree)	RAW VALUE (dBuV)	CORRECTION FACTOR (dB/m)
1	*5580.00	112.2 PK			1.86 V	360	108.0	4.2
2	*5580.00	102.3 AV			1.86 V	360	98.1	4.2
3	11160.00	48.1 PK	74.0	-25.9	1.99 V	62	34.4	13.7
4	11160.00	34.8 AV	54.0	-19.2	1.99 V	62	21.1	13.7
5	#16740.00	55.9 PK	74.0	-18.1	2.26 V	348	40.2	15.7
6	#16740.00	43.9 AV	54.0	-10.1	2.26 V	348	28.2	15.7

REMARKS:

1. Emission Level(dBuV/m) = Raw Value(dBuV) + Correction Factor(dB/m)
2. Correction Factor(dB/m) = Antenna Factor(dB/m) + Cable Factor(dB) – Pre-Amplifier Factor(dB)
3. The other emission levels were very low against the limit.
4. Margin value = Emission Level – Limit value
5. " * ": Fundamental frequency.
6. " # ": The radiated frequency is out of the restricted band.

CHANNEL	TX Channel 140	DETECTOR FUNCTION	Peak (PK)
FREQUENCY RANGE	1GHz ~ 40GHz		Average (AV)

ANTENNA POLARITY & TEST DISTANCE: HORIZONTAL AT 3 M

NO.	FREQ. (MHz)	EMISSION LEVEL (dBuV/m)	LIMIT (dBuV/m)	MARGIN (dB)	ANTENNA HEIGHT (m)	TABLE ANGLE (Degree)	RAW VALUE (dBuV)	CORRECTION FACTOR (dB/m)
1	*5700.00	108.3 PK			3.46 H	295	103.8	4.5
2	*5700.00	96.9 AV			3.46 H	295	92.4	4.5
3	#5725.00	64.1 PK	74.0	-9.9	3.46 H	295	59.7	4.4
4	#5725.00	51.8 AV	54.0	-2.2	3.46 H	295	47.4	4.4
5	11400.00	47.1 PK	74.0	-26.9	1.74 H	161	33.5	13.6
6	11400.00	34.4 AV	54.0	-19.6	1.74 H	161	20.8	13.6
7	#17100.00	55.1 PK	74.0	-18.9	3.18 H	303	37.7	17.4
8	#17100.00	43.1 AV	54.0	-10.9	3.18 H	303	25.7	17.4

ANTENNA POLARITY & TEST DISTANCE: VERTICAL AT 3 M

NO.	FREQ. (MHz)	EMISSION LEVEL (dBuV/m)	LIMIT (dBuV/m)	MARGIN (dB)	ANTENNA HEIGHT (m)	TABLE ANGLE (Degree)	RAW VALUE (dBuV)	CORRECTION FACTOR (dB/m)
1	*5700.00	108.9 PK			1.78 V	360	104.4	4.5
2	*5700.00	98.1 AV			1.78 V	360	93.6	4.5
3	#5725.00	67.9 PK	74.0	-6.1	1.78 V	360	63.5	4.4
4	#5725.00	53.8 AV	54.0	-0.2	1.78 V	360	49.4	4.4
5	11400.00	48.8 PK	74.0	-25.2	2.02 V	43	35.2	13.6
6	11400.00	35.5 AV	54.0	-18.5	2.02 V	43	21.9	13.6
7	#17100.00	56.6 PK	74.0	-17.4	2.35 V	341	39.2	17.4
8	#17100.00	44.5 AV	54.0	-9.5	2.35 V	341	27.1	17.4

REMARKS:

1. Emission Level(dBuV/m) = Raw Value(dBuV) + Correction Factor(dB/m)
2. Correction Factor(dB/m) = Antenna Factor(dB/m) + Cable Factor(dB) – Pre-Amplifier Factor(dB)
3. The other emission levels were very low against the limit.
4. Margin value = Emission Level – Limit value
5. " * ": Fundamental frequency.
6. " # ": The radiated frequency is out of the restricted band.

CHANNEL	TX Channel 144	DETECTOR FUNCTION	Peak (PK)
FREQUENCY RANGE	1GHz ~ 40GHz		Average (AV)

ANTENNA POLARITY & TEST DISTANCE: HORIZONTAL AT 3 M

NO.	FREQ. (MHz)	EMISSION LEVEL (dBuV/m)	LIMIT (dBuV/m)	MARGIN (dB)	ANTENNA HEIGHT (m)	TABLE ANGLE (Degree)	RAW VALUE (dBuV)	CORRECTION FACTOR (dB/m)
1	#5470.00	54.9 PK	74.0	-19.1	3.46 H	300	50.9	4.0
2	#5470.00	43.0 AV	54.0	-11.0	3.46 H	300	39.0	4.0
3	*5720.00	108.0 PK			3.46 H	300	103.8	4.2
4	*5720.00	96.5 AV			3.46 H	300	92.3	4.2
5	#5850.00	64.5 PK	74.0	-9.5	3.46 H	300	59.9	4.6
6	#5850.00	50.8 AV	54.0	-3.2	3.46 H	300	46.2	4.6
7	11440.00	46.6 PK	74.0	-27.4	1.68 H	175	32.8	13.8
8	11440.00	34.2 AV	54.0	-19.8	1.68 H	175	20.4	13.8
9	#17160.00	55.0 PK	74.0	-19.0	3.21 H	319	38.6	16.4
10	#17160.00	43.1 AV	54.0	-10.9	3.21 H	319	26.7	16.4

ANTENNA POLARITY & TEST DISTANCE: VERTICAL AT 3 M

NO.	FREQ. (MHz)	EMISSION LEVEL (dBuV/m)	LIMIT (dBuV/m)	MARGIN (dB)	ANTENNA HEIGHT (m)	TABLE ANGLE (Degree)	RAW VALUE (dBuV)	CORRECTION FACTOR (dB/m)
1	#5470.00	56.9 PK	74.0	-17.1	1.76 V	360	52.9	4.0
2	#5470.00	44.6 AV	54.0	-9.4	1.76 V	360	40.6	4.0
3	*5720.00	108.9 PK			1.76 V	360	104.7	4.2
4	*5720.00	98.3 AV			1.76 V	360	94.1	4.2
5	#5850.00	68.0 PK	74.0	-6.0	1.76 V	360	63.4	4.6
6	#5850.00	53.7 AV	54.0	-0.3	1.76 V	360	49.1	4.6
7	11440.00	49.0 PK	74.0	-25.0	2.00 V	44	35.2	13.8
8	11440.00	35.9 AV	54.0	-18.1	2.00 V	44	22.1	13.8
9	#17160.00	56.8 PK	74.0	-17.2	2.30 V	336	40.4	16.4
10	#17160.00	44.5 AV	54.0	-9.5	2.30 V	336	28.1	16.4

REMARKS:

1. Emission Level(dBuV/m) = Raw Value(dBuV) + Correction Factor(dB/m)
2. Correction Factor(dB/m) = Antenna Factor(dB/m) + Cable Factor(dB) – Pre-Amplifier Factor(dB)
3. The other emission levels were very low against the limit.
4. Margin value = Emission Level – Limit value
5. " * ": Fundamental frequency.
6. " # ": The radiated frequency is out of the restricted band.

802.11ac (VHT20)

CHANNEL	TX Channel 52	DETECTOR FUNCTION	Peak (PK)
FREQUENCY RANGE	1GHz ~ 40GHz		Average (AV)

ANTENNA POLARITY & TEST DISTANCE: HORIZONTAL AT 3 M

NO.	FREQ. (MHz)	EMISSION LEVEL (dBuV/m)	LIMIT (dBuV/m)	MARGIN (dB)	ANTENNA HEIGHT (m)	TABLE ANGLE (Degree)	RAW VALUE (dBuV)	CORRECTION FACTOR (dB/m)
1	5150.00	52.9 PK	74.0	-21.1	2.75 H	360	49.2	3.7
2	5150.00	40.5 AV	54.0	-13.5	2.75 H	360	36.8	3.7
3	*5260.00	112.4 PK			2.75 H	360	108.4	4.0
4	*5260.00	102.7 AV			2.75 H	360	98.7	4.0
5	#10520.00	59.4 PK	74.0	-14.6	1.91 H	56	46.2	13.2
6	#10520.00	46.3 AV	54.0	-7.7	1.91 H	56	33.1	13.2
7	15780.00	55.6 PK	74.0	-18.4	2.47 H	360	42.0	13.6
8	15780.00	44.5 AV	54.0	-9.5	2.47 H	360	30.9	13.6

ANTENNA POLARITY & TEST DISTANCE: VERTICAL AT 3 M

NO.	FREQ. (MHz)	EMISSION LEVEL (dBuV/m)	LIMIT (dBuV/m)	MARGIN (dB)	ANTENNA HEIGHT (m)	TABLE ANGLE (Degree)	RAW VALUE (dBuV)	CORRECTION FACTOR (dB/m)
1	5150.00	51.2 PK	74.0	-22.8	1.59 V	341	47.5	3.7
2	5150.00	38.6 AV	54.0	-15.4	1.59 V	341	34.9	3.7
3	*5260.00	111.9 PK			1.59 V	341	107.9	4.0
4	*5260.00	101.6 AV			1.59 V	341	97.6	4.0
5	#10520.00	58.2 PK	74.0	-15.8	1.56 V	120	45.0	13.2
6	#10520.00	44.6 AV	54.0	-9.4	1.56 V	120	31.4	13.2
7	15780.00	54.5 PK	74.0	-19.5	3.11 V	322	40.9	13.6
8	15780.00	42.5 AV	54.0	-11.5	3.11 V	322	28.9	13.6

REMARKS:

- Emission Level(dBuV/m) = Raw Value(dBuV) + Correction Factor(dB/m)
- Correction Factor(dB/m) = Antenna Factor(dB/m) + Cable Factor(dB) – Pre-Amplifier Factor(dB)
- The other emission levels were very low against the limit.
- Margin value = Emission Level – Limit value
- " * ": Fundamental frequency.
- " # ": The radiated frequency is out of the restricted band.

CHANNEL	TX Channel 60	DETECTOR FUNCTION	Peak (PK)
FREQUENCY RANGE	1GHz ~ 40GHz		Average (AV)

ANTENNA POLARITY & TEST DISTANCE: HORIZONTAL AT 3 M

NO.	FREQ. (MHz)	EMISSION LEVEL (dBuV/m)	LIMIT (dBuV/m)	MARGIN (dB)	ANTENNA HEIGHT (m)	TABLE ANGLE (Degree)	RAW VALUE (dBuV)	CORRECTION FACTOR (dB/m)
1	*5300.00	111.4 PK			2.65 H	339	107.3	4.1
2	*5300.00	101.7 AV			2.65 H	339	97.6	4.1
3	10600.00	60.2 PK	74.0	-13.8	1.89 H	55	46.7	13.5
4	10600.00	46.9 AV	54.0	-7.1	1.89 H	55	33.4	13.5
5	15900.00	55.6 PK	74.0	-18.4	2.41 H	360	42.7	12.9
6	15900.00	44.7 AV	54.0	-9.3	2.41 H	360	31.8	12.9

ANTENNA POLARITY & TEST DISTANCE: VERTICAL AT 3 M

NO.	FREQ. (MHz)	EMISSION LEVEL (dBuV/m)	LIMIT (dBuV/m)	MARGIN (dB)	ANTENNA HEIGHT (m)	TABLE ANGLE (Degree)	RAW VALUE (dBuV)	CORRECTION FACTOR (dB/m)
1	*5300.00	111.8 PK			1.53 V	351	107.7	4.1
2	*5300.00	101.4 AV			1.53 V	351	97.3	4.1
3	10600.00	59.0 PK	74.0	-15.0	1.48 V	117	45.5	13.5
4	10600.00	45.0 AV	54.0	-9.0	1.48 V	117	31.5	13.5
5	15900.00	55.6 PK	74.0	-18.4	3.20 V	293	42.7	12.9
6	15900.00	42.9 AV	54.0	-11.1	3.20 V	293	30.0	12.9

REMARKS:

1. Emission Level(dBuV/m) = Raw Value(dBuV) + Correction Factor(dB/m)
2. Correction Factor(dB/m) = Antenna Factor(dB/m) + Cable Factor(dB) – Pre-Amplifier Factor(dB)
3. The other emission levels were very low against the limit.
4. Margin value = Emission Level – Limit value
5. " * ": Fundamental frequency.

CHANNEL	TX Channel 64	DETECTOR FUNCTION	Peak (PK)
FREQUENCY RANGE	1GHz ~ 40GHz		Average (AV)

ANTENNA POLARITY & TEST DISTANCE: HORIZONTAL AT 3 M

NO.	FREQ. (MHz)	EMISSION LEVEL (dBuV/m)	LIMIT (dBuV/m)	MARGIN (dB)	ANTENNA HEIGHT (m)	TABLE ANGLE (Degree)	RAW VALUE (dBuV)	CORRECTION FACTOR (dB/m)
1	*5320.00	108.2 PK			2.76 H	355	104.1	4.1
2	*5320.00	98.4 AV			2.76 H	355	94.3	4.1
3	5350.00	73.4 PK	74.0	-0.6	2.76 H	355	69.3	4.1
4	5350.00	53.7 AV	54.0	-0.3	2.76 H	355	49.6	4.1
5	10640.00	60.2 PK	74.0	-13.8	1.85 H	45	46.7	13.5
6	10640.00	46.8 AV	54.0	-7.2	1.85 H	45	33.3	13.5
7	15960.00	55.4 PK	74.0	-18.6	2.49 H	360	42.5	12.9
8	15960.00	44.5 AV	54.0	-9.5	2.49 H	360	31.6	12.9

ANTENNA POLARITY & TEST DISTANCE: VERTICAL AT 3 M

NO.	FREQ. (MHz)	EMISSION LEVEL (dBuV/m)	LIMIT (dBuV/m)	MARGIN (dB)	ANTENNA HEIGHT (m)	TABLE ANGLE (Degree)	RAW VALUE (dBuV)	CORRECTION FACTOR (dB/m)
1	*5320.00	107.5 PK			1.48 V	332	103.4	4.1
2	*5320.00	97.2 AV			1.48 V	332	93.1	4.1
3	5350.00	71.4 PK	74.0	-2.6	1.48 V	332	67.3	4.1
4	5350.00	52.2 AV	54.0	-1.8	1.48 V	332	48.1	4.1
5	10640.00	58.5 PK	74.0	-15.5	1.48 V	131	45.0	13.5
6	10640.00	45.2 AV	54.0	-8.8	1.48 V	131	31.7	13.5
7	15960.00	55.8 PK	74.0	-18.2	3.17 V	275	42.9	12.9
8	15960.00	43.4 AV	54.0	-10.6	3.17 V	275	30.5	12.9

REMARKS:

1. Emission Level(dBuV/m) = Raw Value(dBuV) + Correction Factor(dB/m)
2. Correction Factor(dB/m) = Antenna Factor(dB/m) + Cable Factor(dB) – Pre-Amplifier Factor(dB)
3. The other emission levels were very low against the limit.
4. Margin value = Emission Level – Limit value
5. " * ": Fundamental frequency.

CHANNEL	TX Channel 100	DETECTOR FUNCTION	Peak (PK)
FREQUENCY RANGE	1GHz ~ 40GHz		Average (AV)

ANTENNA POLARITY & TEST DISTANCE: HORIZONTAL AT 3 M

NO.	FREQ. (MHz)	EMISSION LEVEL (dBuV/m)	LIMIT (dBuV/m)	MARGIN (dB)	ANTENNA HEIGHT (m)	TABLE ANGLE (Degree)	RAW VALUE (dBuV)	CORRECTION FACTOR (dB/m)
1	#5470.00	68.0 PK	74.0	-6.0	3.57 H	311	63.8	4.2
2	#5470.00	52.7 AV	54.0	-1.3	3.57 H	311	48.5	4.2
3	*5500.00	109.1 PK			3.57 H	311	104.9	4.2
4	*5500.00	98.1 AV			3.57 H	311	93.9	4.2
5	11000.00	46.7 PK	74.0	-27.3	1.68 H	148	32.6	14.1
6	11000.00	34.3 AV	54.0	-19.7	1.68 H	148	20.2	14.1
7	#16500.00	56.3 PK	74.0	-17.7	3.11 H	324	41.8	14.5
8	#16500.00	43.6 AV	54.0	-10.4	3.11 H	324	29.1	14.5

ANTENNA POLARITY & TEST DISTANCE: VERTICAL AT 3 M

NO.	FREQ. (MHz)	EMISSION LEVEL (dBuV/m)	LIMIT (dBuV/m)	MARGIN (dB)	ANTENNA HEIGHT (m)	TABLE ANGLE (Degree)	RAW VALUE (dBuV)	CORRECTION FACTOR (dB/m)
1	#5470.00	71.3 PK	74.0	-2.7	1.86 V	360	67.1	4.2
2	#5470.00	53.9 AV	54.0	-0.1	1.86 V	360	49.7	4.2
3	*5500.00	111.0 PK			1.86 V	360	106.8	4.2
4	*5500.00	100.4 AV			1.86 V	360	96.2	4.2
5	11000.00	48.9 PK	74.0	-25.1	1.89 V	56	34.8	14.1
6	11000.00	35.7 AV	54.0	-18.3	1.89 V	56	21.6	14.1
7	#16500.00	56.2 PK	74.0	-17.8	2.28 V	357	41.7	14.5
8	#16500.00	44.2 AV	54.0	-9.8	2.28 V	357	29.7	14.5

REMARKS:

1. Emission Level(dBuV/m) = Raw Value(dBuV) + Correction Factor(dB/m)
2. Correction Factor(dB/m) = Antenna Factor(dB/m) + Cable Factor(dB) – Pre-Amplifier Factor(dB)
3. The other emission levels were very low against the limit.
4. Margin value = Emission Level – Limit value
5. " * ": Fundamental frequency.
6. " # ": The radiated frequency is out of the restricted band.

CHANNEL	TX Channel 116	DETECTOR FUNCTION	Peak (PK)
FREQUENCY RANGE	1GHz ~ 40GHz		Average (AV)

ANTENNA POLARITY & TEST DISTANCE: HORIZONTAL AT 3 M

NO.	FREQ. (MHz)	EMISSION LEVEL (dBuV/m)	LIMIT (dBuV/m)	MARGIN (dB)	ANTENNA HEIGHT (m)	TABLE ANGLE (Degree)	RAW VALUE (dBuV)	CORRECTION FACTOR (dB/m)
1	*5580.00	112.5 PK			3.57 H	313	108.3	4.2
2	*5580.00	101.7 AV			3.57 H	313	97.5	4.2
3	#5820.00	53.5 PK	74.0	-20.5	3.57 H	313	49.1	4.4
4	#5820.00	46.9 AV	54.0	-7.1	3.57 H	313	42.5	4.4
5	11160.00	45.9 PK	74.0	-28.1	1.67 H	127	32.2	13.7
6	11160.00	33.6 AV	54.0	-20.4	1.67 H	127	19.9	13.7
7	#16740.00	56.3 PK	74.0	-17.7	3.06 H	299	40.6	15.7
8	#16740.00	44.2 AV	54.0	-9.8	3.06 H	299	28.5	15.7

ANTENNA POLARITY & TEST DISTANCE: VERTICAL AT 3 M

NO.	FREQ. (MHz)	EMISSION LEVEL (dBuV/m)	LIMIT (dBuV/m)	MARGIN (dB)	ANTENNA HEIGHT (m)	TABLE ANGLE (Degree)	RAW VALUE (dBuV)	CORRECTION FACTOR (dB/m)
1	*5580.00	114.0 PK			1.91 V	360	109.8	4.2
2	*5580.00	103.6 AV			1.91 V	360	99.4	4.2
3	#5820.00	57.7 PK	74.0	-16.3	1.91 V	360	53.3	4.4
4	#5820.00	48.5 AV	54.0	-5.5	1.91 V	360	44.1	4.4
5	11160.00	48.5 PK	74.0	-25.5	1.96 V	43	34.8	13.7
6	11160.00	35.7 AV	54.0	-18.3	1.96 V	43	22.0	13.7
7	#16740.00	56.0 PK	74.0	-18.0	2.24 V	360	40.3	15.7
8	#16740.00	44.1 AV	54.0	-9.9	2.24 V	360	28.4	15.7

REMARKS:

1. Emission Level(dBuV/m) = Raw Value(dBuV) + Correction Factor(dB/m)
2. Correction Factor(dB/m) = Antenna Factor(dB/m) + Cable Factor(dB) – Pre-Amplifier Factor(dB)
3. The other emission levels were very low against the limit.
4. Margin value = Emission Level – Limit value
5. " * ": Fundamental frequency.
6. " # ": The radiated frequency is out of the restricted band.

CHANNEL	TX Channel 140	DETECTOR FUNCTION	Peak (PK)
FREQUENCY RANGE	1GHz ~ 40GHz		Average (AV)

ANTENNA POLARITY & TEST DISTANCE: HORIZONTAL AT 3 M

NO.	FREQ. (MHz)	EMISSION LEVEL (dBuV/m)	LIMIT (dBuV/m)	MARGIN (dB)	ANTENNA HEIGHT (m)	TABLE ANGLE (Degree)	RAW VALUE (dBuV)	CORRECTION FACTOR (dB/m)
1	*5700.00	108.5 PK			3.52 H	328	104.0	4.5
2	*5700.00	97.1 AV			3.52 H	328	92.6	4.5
3	#5725.00	64.2 PK	74.0	-9.8	3.52 H	328	59.8	4.4
4	#5725.00	52.2 AV	54.0	-1.8	3.52 H	328	47.8	4.4
5	11400.00	45.8 PK	74.0	-28.2	1.64 H	128	32.2	13.6
6	11400.00	33.3 AV	54.0	-20.7	1.64 H	128	19.7	13.6
7	#17100.00	56.6 PK	74.0	-17.4	3.08 H	318	39.2	17.4
8	#17100.00	44.0 AV	54.0	-10.0	3.08 H	318	26.6	17.4

ANTENNA POLARITY & TEST DISTANCE: VERTICAL AT 3 M

NO.	FREQ. (MHz)	EMISSION LEVEL (dBuV/m)	LIMIT (dBuV/m)	MARGIN (dB)	ANTENNA HEIGHT (m)	TABLE ANGLE (Degree)	RAW VALUE (dBuV)	CORRECTION FACTOR (dB/m)
1	*5700.00	109.2 PK			1.69 V	356	104.7	4.5
2	*5700.00	98.3 AV			1.69 V	356	93.8	4.5
3	#5725.00	67.5 PK	74.0	-6.5	1.69 V	356	63.1	4.4
4	#5725.00	53.9 AV	54.0	-0.1	1.69 V	356	49.5	4.4
5	11400.00	47.9 PK	74.0	-26.1	1.94 V	31	34.3	13.6
6	11400.00	34.9 AV	54.0	-19.1	1.94 V	31	21.3	13.6
7	#17100.00	56.6 PK	74.0	-17.4	2.45 V	352	39.2	17.4
8	#17100.00	44.1 AV	54.0	-9.9	2.45 V	352	26.7	17.4

REMARKS:

1. Emission Level(dBuV/m) = Raw Value(dBuV) + Correction Factor(dB/m)
2. Correction Factor(dB/m) = Antenna Factor(dB/m) + Cable Factor(dB) – Pre-Amplifier Factor(dB)
3. The other emission levels were very low against the limit.
4. Margin value = Emission Level – Limit value
5. " * ": Fundamental frequency.
6. " # ": The radiated frequency is out of the restricted band.

CHANNEL	TX Channel 144	DETECTOR FUNCTION	Peak (PK)
FREQUENCY RANGE	1GHz ~ 40GHz		Average (AV)

ANTENNA POLARITY & TEST DISTANCE: HORIZONTAL AT 3 M

NO.	FREQ. (MHz)	EMISSION LEVEL (dBuV/m)	LIMIT (dBuV/m)	MARGIN (dB)	ANTENNA HEIGHT (m)	TABLE ANGLE (Degree)	RAW VALUE (dBuV)	CORRECTION FACTOR (dB/m)
1	#5470.00	54.7 PK	74.0	-19.3	3.51 H	289	50.7	4.0
2	#5470.00	42.7 AV	54.0	-11.3	3.51 H	289	38.7	4.0
3	*5720.00	107.5 PK			3.50 H	300	103.3	4.2
4	*5720.00	96.1 AV			3.50 H	300	91.9	4.2
5	#5850.00	64.0 PK	74.0	-10.0	3.50 H	300	59.4	4.6
6	#5850.00	51.7 AV	54.0	-2.3	3.50 H	300	47.1	4.6
7	11440.00	46.1 PK	74.0	-27.9	1.67 H	188	32.3	13.8
8	11440.00	34.0 AV	54.0	-20.0	1.67 H	188	20.2	13.8
9	#17160.00	54.4 PK	74.0	-19.6	3.26 H	333	38.0	16.4
10	#17160.00	42.7 AV	54.0	-11.3	3.26 H	333	26.3	16.4

ANTENNA POLARITY & TEST DISTANCE: VERTICAL AT 3 M

NO.	FREQ. (MHz)	EMISSION LEVEL (dBuV/m)	LIMIT (dBuV/m)	MARGIN (dB)	ANTENNA HEIGHT (m)	TABLE ANGLE (Degree)	RAW VALUE (dBuV)	CORRECTION FACTOR (dB/m)
1	#5470.00	56.5 PK	74.0	-17.5	1.78 V	360	52.5	4.0
2	#5470.00	44.1 AV	54.0	-9.9	1.78 V	360	40.1	4.0
3	*5720.00	108.8 PK			1.74 V	360	104.6	4.2
4	*5720.00	98.4 AV			1.74 V	360	94.2	4.2
5	#5850.00	67.9 PK	74.0	-6.1	1.74 V	360	63.3	4.6
6	#5850.00	53.8 AV	54.0	-0.2	1.74 V	360	49.2	4.6
7	11440.00	49.5 PK	74.0	-24.5	2.00 V	43	35.7	13.8
8	11440.00	36.3 AV	54.0	-17.7	2.00 V	43	22.5	13.8
9	#17160.00	57.0 PK	74.0	-17.0	2.35 V	336	40.6	16.4
10	#17160.00	44.9 AV	54.0	-9.1	2.35 V	336	28.5	16.4

REMARKS:

1. Emission Level(dBuV/m) = Raw Value(dBuV) + Correction Factor(dB/m)
2. Correction Factor(dB/m) = Antenna Factor(dB/m) + Cable Factor(dB) – Pre-Amplifier Factor(dB)
3. The other emission levels were very low against the limit.
4. Margin value = Emission Level – Limit value
5. " * ": Fundamental frequency.
6. " # ": The radiated frequency is out of the restricted band.

802.11ac (VHT40)

CHANNEL	TX Channel 54	DETECTOR FUNCTION	Peak (PK)
FREQUENCY RANGE	1GHz ~ 40GHz		Average (AV)

ANTENNA POLARITY & TEST DISTANCE: HORIZONTAL AT 3 M

NO.	FREQ. (MHz)	EMISSION LEVEL (dBuV/m)	LIMIT (dBuV/m)	MARGIN (dB)	ANTENNA HEIGHT (m)	TABLE ANGLE (Degree)	RAW VALUE (dBuV)	CORRECTION FACTOR (dB/m)
1	5150.00	53.3 PK	74.0	-20.7	1.39 H	334	49.6	3.7
2	5150.00	40.5 AV	54.0	-13.5	1.39 H	334	36.8	3.7
3	*5270.00	111.1 PK			1.39 H	334	107.1	4.0
4	*5270.00	99.1 AV			1.39 H	334	95.1	4.0
5	#10540.00	59.7 PK	74.0	-14.3	1.77 H	30	46.4	13.3
6	#10540.00	46.6 AV	54.0	-7.4	1.77 H	30	33.3	13.3
7	15810.00	55.4 PK	74.0	-18.6	2.35 H	357	42.0	13.4
8	15810.00	44.5 AV	54.0	-9.5	2.35 H	357	31.1	13.4

ANTENNA POLARITY & TEST DISTANCE: VERTICAL AT 3 M

NO.	FREQ. (MHz)	EMISSION LEVEL (dBuV/m)	LIMIT (dBuV/m)	MARGIN (dB)	ANTENNA HEIGHT (m)	TABLE ANGLE (Degree)	RAW VALUE (dBuV)	CORRECTION FACTOR (dB/m)
1	5150.00	51.7 PK	74.0	-22.3	1.49 V	351	48.0	3.7
2	5150.00	39.5 AV	54.0	-14.5	1.49 V	351	35.8	3.7
3	*5270.00	109.6 PK			1.49 V	351	105.6	4.0
4	*5270.00	97.7 AV			1.49 V	351	93.7	4.0
5	#10540.00	58.5 PK	74.0	-15.5	1.45 V	139	45.2	13.3
6	#10540.00	44.9 AV	54.0	-9.1	1.45 V	139	31.6	13.3
7	15810.00	55.7 PK	74.0	-18.3	3.19 V	312	42.3	13.4
8	15810.00	43.3 AV	54.0	-10.7	3.19 V	312	29.9	13.4

REMARKS:

- Emission Level(dBuV/m) = Raw Value(dBuV) + Correction Factor(dB/m)
- Correction Factor(dB/m) = Antenna Factor(dB/m) + Cable Factor(dB) – Pre-Amplifier Factor(dB)
- The other emission levels were very low against the limit.
- Margin value = Emission Level – Limit value
- " * ": Fundamental frequency.
- " # ": The radiated frequency is out of the restricted band.

CHANNEL	TX Channel 62	DETECTOR FUNCTION	Peak (PK)
FREQUENCY RANGE	1GHz ~ 40GHz		Average (AV)

ANTENNA POLARITY & TEST DISTANCE: HORIZONTAL AT 3 M

NO.	FREQ. (MHz)	EMISSION LEVEL (dBuV/m)	LIMIT (dBuV/m)	MARGIN (dB)	ANTENNA HEIGHT (m)	TABLE ANGLE (Degree)	RAW VALUE (dBuV)	CORRECTION FACTOR (dB/m)
1	*5310.00	102.8 PK			1.31 H	335	98.7	4.1
2	*5310.00	91.1 AV			1.31 H	335	87.0	4.1
3	5350.00	71.6 PK	74.0	-2.4	1.31 H	335	67.5	4.1
4	5350.00	53.9 AV	54.0	-0.1	1.31 H	335	49.8	4.1
5	10620.00	59.3 PK	74.0	-14.7	1.88 H	32	45.8	13.5
6	10620.00	46.6 AV	54.0	-7.4	1.88 H	32	33.1	13.5
7	15930.00	54.5 PK	74.0	-19.5	2.42 H	360	41.7	12.8
8	15930.00	43.9 AV	54.0	-10.1	2.42 H	360	31.1	12.8

ANTENNA POLARITY & TEST DISTANCE: VERTICAL AT 3 M

NO.	FREQ. (MHz)	EMISSION LEVEL (dBuV/m)	LIMIT (dBuV/m)	MARGIN (dB)	ANTENNA HEIGHT (m)	TABLE ANGLE (Degree)	RAW VALUE (dBuV)	CORRECTION FACTOR (dB/m)
1	*5310.00	102.5 PK			1.41 V	349	98.4	4.1
2	*5310.00	90.2 AV			1.41 V	349	86.1	4.1
3	5350.00	70.5 PK	74.0	-3.5	1.41 V	349	66.4	4.1
4	5350.00	53.0 AV	54.0	-1.0	1.41 V	349	48.9	4.1
5	10620.00	57.9 PK	74.0	-16.1	1.47 V	121	44.4	13.5
6	10620.00	44.3 AV	54.0	-9.7	1.47 V	121	30.8	13.5
7	15930.00	54.9 PK	74.0	-19.1	3.16 V	307	42.1	12.8
8	15930.00	42.6 AV	54.0	-11.4	3.16 V	307	29.8	12.8

REMARKS:

1. Emission Level(dBuV/m) = Raw Value(dBuV) + Correction Factor(dB/m)
2. Correction Factor(dB/m) = Antenna Factor(dB/m) + Cable Factor(dB) – Pre-Amplifier Factor(dB)
3. The other emission levels were very low against the limit.
4. Margin value = Emission Level – Limit value
5. " * ": Fundamental frequency.

CHANNEL	TX Channel 102	DETECTOR FUNCTION	Peak (PK)
FREQUENCY RANGE	1GHz ~ 40GHz		Average (AV)

ANTENNA POLARITY & TEST DISTANCE: HORIZONTAL AT 3 M

NO.	FREQ. (MHz)	EMISSION LEVEL (dBuV/m)	LIMIT (dBuV/m)	MARGIN (dB)	ANTENNA HEIGHT (m)	TABLE ANGLE (Degree)	RAW VALUE (dBuV)	CORRECTION FACTOR (dB/m)
1	#5470.00	69.3 PK	74.0	-4.7	3.51 H	291	65.1	4.2
2	#5470.00	52.3 AV	54.0	-1.7	3.51 H	291	48.1	4.2
3	*5510.00	104.1 PK			3.51 H	291	99.9	4.2
4	*5510.00	94.4 AV			3.51 H	291	90.2	4.2
5	11020.00	46.2 PK	74.0	-27.8	1.69 H	162	32.2	14.0
6	11020.00	33.8 AV	54.0	-20.2	1.69 H	162	19.8	14.0
7	#16530.00	56.1 PK	74.0	-17.9	3.11 H	313	41.2	14.9
8	#16530.00	43.6 AV	54.0	-10.4	3.11 H	313	28.7	14.9

ANTENNA POLARITY & TEST DISTANCE: VERTICAL AT 3 M

NO.	FREQ. (MHz)	EMISSION LEVEL (dBuV/m)	LIMIT (dBuV/m)	MARGIN (dB)	ANTENNA HEIGHT (m)	TABLE ANGLE (Degree)	RAW VALUE (dBuV)	CORRECTION FACTOR (dB/m)
1	#5470.00	73.5 PK	74.0	-0.5	1.90 V	336	69.3	4.2
2	#5470.00	53.8 AV	54.0	-0.2	1.90 V	336	49.6	4.2
3	*5510.00	104.4 PK			1.90 V	336	100.2	4.2
4	*5510.00	95.4 AV			1.90 V	336	91.2	4.2
5	11020.00	48.5 PK	74.0	-25.5	1.87 V	55	34.5	14.0
6	11020.00	35.8 AV	54.0	-18.2	1.87 V	55	21.8	14.0
7	#16530.00	57.2 PK	74.0	-16.8	2.37 V	355	42.3	14.9
8	#16530.00	45.3 AV	54.0	-8.7	2.37 V	355	30.4	14.9

REMARKS:

1. Emission Level(dBuV/m) = Raw Value(dBuV) + Correction Factor(dB/m)
2. Correction Factor(dB/m) = Antenna Factor(dB/m) + Cable Factor(dB) – Pre-Amplifier Factor(dB)
3. The other emission levels were very low against the limit.
4. Margin value = Emission Level – Limit value
5. " * ": Fundamental frequency.
6. " # ": The radiated frequency is out of the restricted band.

CHANNEL	TX Channel 110	DETECTOR FUNCTION	Peak (PK)
FREQUENCY RANGE	1GHz ~ 40GHz		Average (AV)

ANTENNA POLARITY & TEST DISTANCE: HORIZONTAL AT 3 M

NO.	FREQ. (MHz)	EMISSION LEVEL (dBuV/m)	LIMIT (dBuV/m)	MARGIN (dB)	ANTENNA HEIGHT (m)	TABLE ANGLE (Degree)	RAW VALUE (dBuV)	CORRECTION FACTOR (dB/m)
1	#5470.00	65.0 PK	74.0	-9.0	3.59 H	332	60.8	4.2
2	#5470.00	51.9 AV	54.0	-2.1	3.59 H	332	47.7	4.2
3	*5550.00	110.0 PK			3.59 H	332	105.8	4.2
4	*5550.00	100.1 AV			3.59 H	332	95.9	4.2
5	11100.00	46.3 PK	74.0	-27.7	1.66 H	111	32.5	13.8
6	11100.00	33.8 AV	54.0	-20.2	1.66 H	111	20.0	13.8
7	#16650.00	55.8 PK	74.0	-18.2	3.14 H	309	40.2	15.6
8	#16650.00	43.0 AV	54.0	-11.0	3.14 H	309	27.4	15.6

ANTENNA POLARITY & TEST DISTANCE: VERTICAL AT 3 M

NO.	FREQ. (MHz)	EMISSION LEVEL (dBuV/m)	LIMIT (dBuV/m)	MARGIN (dB)	ANTENNA HEIGHT (m)	TABLE ANGLE (Degree)	RAW VALUE (dBuV)	CORRECTION FACTOR (dB/m)
1	#5470.00	70.1 PK	74.0	-3.9	1.70 V	351	65.9	4.2
2	#5470.00	53.9 AV	54.0	-0.1	1.70 V	351	49.7	4.2
3	*5550.00	110.6 PK			1.70 V	351	106.4	4.2
4	*5550.00	100.9 AV			1.70 V	351	96.7	4.2
5	11100.00	48.2 PK	74.0	-25.8	2.03 V	58	34.4	13.8
6	11100.00	35.5 AV	54.0	-18.5	2.03 V	58	21.7	13.8
7	#16650.00	56.5 PK	74.0	-17.5	2.31 V	360	40.9	15.6
8	#16650.00	44.2 AV	54.0	-9.8	2.31 V	360	28.6	15.6

REMARKS:

1. Emission Level(dBuV/m) = Raw Value(dBuV) + Correction Factor(dB/m)
2. Correction Factor(dB/m) = Antenna Factor(dB/m) + Cable Factor(dB) – Pre-Amplifier Factor(dB)
3. The other emission levels were very low against the limit.
4. Margin value = Emission Level – Limit value
5. " * ": Fundamental frequency.
6. " # ": The radiated frequency is out of the restricted band.

CHANNEL	TX Channel 134	DETECTOR FUNCTION	Peak (PK)
FREQUENCY RANGE	1GHz ~ 40GHz		Average (AV)

ANTENNA POLARITY & TEST DISTANCE: HORIZONTAL AT 3 M

NO.	FREQ. (MHz)	EMISSION LEVEL (dBuV/m)	LIMIT (dBuV/m)	MARGIN (dB)	ANTENNA HEIGHT (m)	TABLE ANGLE (Degree)	RAW VALUE (dBuV)	CORRECTION FACTOR (dB/m)
1	*5670.00	106.2 PK			3.57 H	330	101.9	4.3
2	*5670.00	96.1 AV			3.57 H	330	91.8	4.3
3	#5725.00	64.1 PK	74.0	-9.9	3.57 H	330	59.7	4.4
4	#5725.00	51.8 AV	54.0	-2.2	3.57 H	330	47.4	4.4
5	11340.00	45.5 PK	74.0	-28.5	1.66 H	155	31.9	13.6
6	11340.00	33.2 AV	54.0	-20.8	1.66 H	155	19.6	13.6
7	#17010.00	56.7 PK	74.0	-17.3	3.13 H	319	39.6	17.1
8	#17010.00	44.4 AV	54.0	-9.6	3.13 H	319	27.3	17.1

ANTENNA POLARITY & TEST DISTANCE: VERTICAL AT 3 M

NO.	FREQ. (MHz)	EMISSION LEVEL (dBuV/m)	LIMIT (dBuV/m)	MARGIN (dB)	ANTENNA HEIGHT (m)	TABLE ANGLE (Degree)	RAW VALUE (dBuV)	CORRECTION FACTOR (dB/m)
1	*5670.00	105.8 PK			1.77 V	341	101.5	4.3
2	*5670.00	96.4 AV			1.77 V	341	92.1	4.3
3	#5725.00	68.0 PK	74.0	-6.0	1.77 V	341	63.6	4.4
4	#5725.00	53.7 AV	54.0	-0.3	1.77 V	341	49.3	4.4
5	11340.00	49.1 PK	74.0	-24.9	1.92 V	27	35.5	13.6
6	11340.00	35.8 AV	54.0	-18.2	1.92 V	27	22.2	13.6
7	#17010.00	55.9 PK	74.0	-18.1	2.20 V	336	38.8	17.1
8	#17010.00	43.8 AV	54.0	-10.2	2.20 V	336	26.7	17.1

REMARKS:

1. Emission Level(dBuV/m) = Raw Value(dBuV) + Correction Factor(dB/m)
2. Correction Factor(dB/m) = Antenna Factor(dB/m) + Cable Factor(dB) – Pre-Amplifier Factor(dB)
3. The other emission levels were very low against the limit.
4. Margin value = Emission Level – Limit value
5. " * ": Fundamental frequency.
6. " # ": The radiated frequency is out of the restricted band.

CHANNEL	TX Channel 142	DETECTOR FUNCTION	Peak (PK)
FREQUENCY RANGE	1GHz ~ 40GHz		Average (AV)

ANTENNA POLARITY & TEST DISTANCE: HORIZONTAL AT 3 M

NO.	FREQ. (MHz)	EMISSION LEVEL (dBuV/m)	LIMIT (dBuV/m)	MARGIN (dB)	ANTENNA HEIGHT (m)	TABLE ANGLE (Degree)	RAW VALUE (dBuV)	CORRECTION FACTOR (dB/m)
1	#5470.00	56.6 PK	74.0	-17.4	3.55 H	329	52.6	4.0
2	#5470.00	44.1 AV	54.0	-9.9	3.55 H	329	40.1	4.0
3	*5710.00	106.6 PK			3.55 H	329	102.3	4.3
4	*5710.00	96.5 AV			3.55 H	329	92.2	4.3
5	#5850.00	63.5 PK	74.0	-10.5	3.55 H	329	58.9	4.6
6	#5850.00	50.6 AV	54.0	-3.4	3.55 H	329	46.0	4.6
7	11420.00	45.4 PK	74.0	-28.6	1.69 H	144	31.6	13.8
8	11420.00	32.9 AV	54.0	-21.1	1.69 H	144	19.1	13.8
9	#17130.00	57.2 PK	74.0	-16.8	3.14 H	314	40.7	16.5
10	#17130.00	44.8 AV	54.0	-9.2	3.14 H	314	28.3	16.5

ANTENNA POLARITY & TEST DISTANCE: VERTICAL AT 3 M

NO.	FREQ. (MHz)	EMISSION LEVEL (dBuV/m)	LIMIT (dBuV/m)	MARGIN (dB)	ANTENNA HEIGHT (m)	TABLE ANGLE (Degree)	RAW VALUE (dBuV)	CORRECTION FACTOR (dB/m)
1	#5470.00	57.0 PK	74.0	-17.0	1.78 V	329	53.0	4.0
2	#5470.00	44.4 AV	54.0	-9.6	1.78 V	329	40.4	4.0
3	*5710.00	105.6 PK			1.78 V	329	101.3	4.3
4	*5710.00	96.4 AV			1.78 V	329	92.1	4.3
5	#5850.00	68.1 PK	74.0	-5.9	1.78 V	329	63.5	4.6
6	#5850.00	53.6 AV	54.0	-0.4	1.78 V	329	49.0	4.6
7	11420.00	49.1 PK	74.0	-24.9	1.93 V	18	35.3	13.8
8	11420.00	36.1 AV	54.0	-17.9	1.93 V	18	22.3	13.8
9	#17130.00	55.7 PK	74.0	-18.3	2.22 V	349	39.2	16.5
10	#17130.00	43.4 AV	54.0	-10.6	2.22 V	349	26.9	16.5

REMARKS:

1. Emission Level(dBuV/m) = Raw Value(dBuV) + Correction Factor(dB/m)
2. Correction Factor(dB/m) = Antenna Factor(dB/m) + Cable Factor(dB) – Pre-Amplifier Factor(dB)
3. The other emission levels were very low against the limit.
4. Margin value = Emission Level – Limit value
5. " * ": Fundamental frequency.
6. " # ": The radiated frequency is out of the restricted band.

802.11ac (VHT80)

CHANNEL	TX Channel 58	DETECTOR FUNCTION	Peak (PK)
FREQUENCY RANGE	1GHz ~ 40GHz		Average (AV)

ANTENNA POLARITY & TEST DISTANCE: HORIZONTAL AT 3 M

NO.	FREQ. (MHz)	EMISSION LEVEL (dBuV/m)	LIMIT (dBuV/m)	MARGIN (dB)	ANTENNA HEIGHT (m)	TABLE ANGLE (Degree)	RAW VALUE (dBuV)	CORRECTION FACTOR (dB/m)
1	5150.00	53.2 PK	74.0	-20.8	1.45 H	360	49.5	3.7
2	5150.00	40.3 AV	54.0	-13.7	1.45 H	360	36.6	3.7
3	*5290.00	100.4 PK			1.45 H	360	96.3	4.1
4	*5290.00	90.8 AV			1.45 H	360	86.7	4.1
5	5350.00	71.4 PK	74.0	-2.6	1.45 H	360	67.3	4.1
6	5350.00	53.9 AV	54.0	-0.1	1.45 H	360	49.8	4.1
7	#10580.00	59.3 PK	74.0	-14.7	1.80 H	35	45.9	13.4
8	#10580.00	46.2 AV	54.0	-7.8	1.80 H	35	32.8	13.4
9	15870.00	55.9 PK	74.0	-18.1	2.43 H	358	42.9	13.0
10	15870.00	44.8 AV	54.0	-9.2	2.43 H	358	31.8	13.0

ANTENNA POLARITY & TEST DISTANCE: VERTICAL AT 3 M

NO.	FREQ. (MHz)	EMISSION LEVEL (dBuV/m)	LIMIT (dBuV/m)	MARGIN (dB)	ANTENNA HEIGHT (m)	TABLE ANGLE (Degree)	RAW VALUE (dBuV)	CORRECTION FACTOR (dB/m)
1	5150.00	51.3 PK	74.0	-22.7	1.47 V	347	47.6	3.7
2	5150.00	38.8 AV	54.0	-15.2	1.47 V	347	35.1	3.7
3	*5290.00	98.6 PK			1.47 V	347	94.5	4.1
4	*5290.00	89.4 AV			1.47 V	347	85.3	4.1
5	5350.00	69.5 PK	74.0	-4.5	1.47 V	347	65.4	4.1
6	5350.00	52.4 AV	54.0	-1.6	1.47 V	347	48.3	4.1
7	#10580.00	57.5 PK	74.0	-16.5	1.58 V	113	44.1	13.4
8	#10580.00	44.0 AV	54.0	-10.0	1.58 V	113	30.6	13.4
9	15870.00	56.0 PK	74.0	-18.0	3.07 V	321	43.0	13.0
10	15870.00	43.8 AV	54.0	-10.2	3.07 V	321	30.8	13.0

REMARKS:

- Emission Level(dBuV/m) = Raw Value(dBuV) + Correction Factor(dB/m)
- Correction Factor(dB/m) = Antenna Factor(dB/m) + Cable Factor(dB) – Pre-Amplifier Factor(dB)
- The other emission levels were very low against the limit.
- Margin value = Emission Level – Limit value
- " * ": Fundamental frequency.
- " # ": The radiated frequency is out of the restricted band.

CHANNEL	TX Channel 106	DETECTOR FUNCTION	Peak (PK)
FREQUENCY RANGE	1GHz ~ 40GHz		Average (AV)

ANTENNA POLARITY & TEST DISTANCE: HORIZONTAL AT 3 M

NO.	FREQ. (MHz)	EMISSION LEVEL (dBuV/m)	LIMIT (dBuV/m)	MARGIN (dB)	ANTENNA HEIGHT (m)	TABLE ANGLE (Degree)	RAW VALUE (dBuV)	CORRECTION FACTOR (dB/m)
1	#5470.00	68.5 PK	74.0	-5.5	3.55 H	335	64.3	4.2
2	#5470.00	52.0 AV	54.0	-2.0	3.55 H	335	47.8	4.2
3	*5530.00	99.7 PK			3.55 H	335	95.5	4.2
4	*5530.00	91.0 AV			3.55 H	335	86.8	4.2
5	#5725.00	46.8 PK	74.0	-27.2	3.55 H	335	42.4	4.4
6	#5725.00	37.6 AV	54.0	-16.4	3.55 H	335	33.2	4.4
7	11060.00	46.3 PK	74.0	-27.7	1.65 H	150	32.4	13.9
8	11060.00	33.5 AV	54.0	-20.5	1.65 H	150	19.6	13.9
9	#16590.00	56.7 PK	74.0	-17.3	3.19 H	294	41.1	15.6
10	#16590.00	43.7 AV	54.0	-10.3	3.19 H	294	28.1	15.6

ANTENNA POLARITY & TEST DISTANCE: VERTICAL AT 3 M

NO.	FREQ. (MHz)	EMISSION LEVEL (dBuV/m)	LIMIT (dBuV/m)	MARGIN (dB)	ANTENNA HEIGHT (m)	TABLE ANGLE (Degree)	RAW VALUE (dBuV)	CORRECTION FACTOR (dB/m)
1	#5470.00	71.6 PK	74.0	-2.4	1.96 V	335	67.4	4.2
2	#5470.00	53.9 AV	54.0	-0.1	1.96 V	335	49.7	4.2
3	*5530.00	101.4 PK			1.96 V	335	97.2	4.2
4	*5530.00	92.3 AV			1.96 V	335	88.1	4.2
5	#5725.00	51.2 PK	74.0	-22.8	1.96 V	335	46.8	4.4
6	#5725.00	40.5 AV	54.0	-13.5	1.96 V	335	36.1	4.4
7	11060.00	48.5 PK	74.0	-25.5	2.00 V	27	34.6	13.9
8	11060.00	35.5 AV	54.0	-18.5	2.00 V	27	21.6	13.9
9	#16590.00	58.2 PK	74.0	-15.8	2.33 V	338	42.6	15.6
10	#16590.00	45.4 AV	54.0	-8.6	2.33 V	338	29.8	15.6

REMARKS:

- Emission Level(dBuV/m) = Raw Value(dBuV) + Correction Factor(dB/m)
- Correction Factor(dB/m) = Antenna Factor(dB/m) + Cable Factor(dB) – Pre-Amplifier Factor(dB)
- The other emission levels were very low against the limit.
- Margin value = Emission Level – Limit value
- " * ": Fundamental frequency.
- " # ": The radiated frequency is out of the restricted band.

CHANNEL	TX Channel 122	DETECTOR FUNCTION	Peak (PK)
FREQUENCY RANGE	1GHz ~ 40GHz		Average (AV)

ANTENNA POLARITY & TEST DISTANCE: HORIZONTAL AT 3 M

NO.	FREQ. (MHz)	EMISSION LEVEL (dBuV/m)	LIMIT (dBuV/m)	MARGIN (dB)	ANTENNA HEIGHT (m)	TABLE ANGLE (Degree)	RAW VALUE (dBuV)	CORRECTION FACTOR (dB/m)
1	*5610.00	100.3 PK			3.44 H	307	95.9	4.4
2	*5610.00	91.6 AV			3.44 H	307	87.2	4.4
3	#5725.00	63.0 PK	74.0	-11.0	3.44 H	307	58.6	4.4
4	#5725.00	52.2 AV	54.0	-1.8	3.44 H	307	47.8	4.4
5	11220.00	46.0 PK	74.0	-28.0	1.68 H	124	32.3	13.7
6	11220.00	33.4 AV	54.0	-20.6	1.68 H	124	19.7	13.7
7	#16830.00	54.9 PK	74.0	-19.1	3.07 H	320	39.0	15.9
8	#16830.00	43.0 AV	54.0	-11.0	3.07 H	320	27.1	15.9

ANTENNA POLARITY & TEST DISTANCE: VERTICAL AT 3 M

NO.	FREQ. (MHz)	EMISSION LEVEL (dBuV/m)	LIMIT (dBuV/m)	MARGIN (dB)	ANTENNA HEIGHT (m)	TABLE ANGLE (Degree)	RAW VALUE (dBuV)	CORRECTION FACTOR (dB/m)
1	*5610.00	103.6 PK			1.93 V	355	99.2	4.4
2	*5610.00	94.1 AV			1.93 V	355	89.7	4.4
3	#5725.00	66.2 PK	74.0	-7.8	1.93 V	355	61.8	4.4
4	#5725.00	53.7 AV	54.0	-0.3	1.93 V	355	49.3	4.4
5	11220.00	48.1 PK	74.0	-25.9	1.97 V	10	34.4	13.7
6	11220.00	35.5 AV	54.0	-18.5	1.97 V	10	21.8	13.7
7	#16830.00	55.5 PK	74.0	-18.5	2.34 V	341	39.6	15.9
8	#16830.00	43.0 AV	54.0	-11.0	2.34 V	341	27.1	15.9

REMARKS:

1. Emission Level(dBuV/m) = Raw Value(dBuV) + Correction Factor(dB/m)
2. Correction Factor(dB/m) = Antenna Factor(dB/m) + Cable Factor(dB) – Pre-Amplifier Factor(dB)
3. The other emission levels were very low against the limit.
4. Margin value = Emission Level – Limit value
5. " * ": Fundamental frequency.
6. " # ": The radiated frequency is out of the restricted band.

CHANNEL	TX Channel 138	DETECTOR FUNCTION	Peak (PK)
FREQUENCY RANGE	1GHz ~ 40GHz		Average (AV)

ANTENNA POLARITY & TEST DISTANCE: HORIZONTAL AT 3 M

NO.	FREQ. (MHz)	EMISSION LEVEL (dBuV/m)	LIMIT (dBuV/m)	MARGIN (dB)	ANTENNA HEIGHT (m)	TABLE ANGLE (Degree)	RAW VALUE (dBuV)	CORRECTION FACTOR (dB/m)
1	#5470.00	62.7 PK	74.0	-11.3	3.43 H	296	58.7	4.0
2	#5470.00	52.0 AV	54.0	-2.0	3.43 H	296	48.0	4.0
3	*5690.00	100.5 PK			3.47 H	301	96.3	4.2
4	*5690.00	91.5 AV			3.47 H	301	87.3	4.2
5	#5850.00	64.2 PK	74.0	-9.8	3.47 H	301	59.6	4.6
6	#5850.00	50.3 AV	54.0	-3.7	3.47 H	301	45.7	4.6
7	11380.00	46.2 PK	74.0	-27.8	1.68 H	123	32.5	13.7
8	11380.00	33.8 AV	54.0	-20.2	1.68 H	123	20.1	13.7
9	#17070.00	54.8 PK	74.0	-19.2	3.11 H	310	38.2	16.6
10	#17070.00	42.7 AV	54.0	-11.3	3.11 H	310	26.1	16.6

ANTENNA POLARITY & TEST DISTANCE: VERTICAL AT 3 M

NO.	FREQ. (MHz)	EMISSION LEVEL (dBuV/m)	LIMIT (dBuV/m)	MARGIN (dB)	ANTENNA HEIGHT (m)	TABLE ANGLE (Degree)	RAW VALUE (dBuV)	CORRECTION FACTOR (dB/m)
1	#5470.00	66.2 PK	74.0	-7.8	1.91 V	360	62.2	4.0
2	#5470.00	53.6 AV	54.0	-0.4	1.91 V	360	49.6	4.0
3	*5690.00	103.5 PK			1.91 V	360	99.3	4.2
4	*5690.00	93.8 AV			1.91 V	360	89.6	4.2
5	#5850.00	68.0 PK	74.0	-6.0	1.91 V	360	63.4	4.6
6	#5850.00	53.8 AV	54.0	-0.2	1.91 V	360	49.2	4.6
7	11380.00	48.0 PK	74.0	-26.0	2.02 V	2	34.3	13.7
8	11380.00	35.5 AV	54.0	-18.5	2.02 V	2	21.8	13.7
9	#17070.00	55.1 PK	74.0	-18.9	2.38 V	352	38.5	16.6
10	#17070.00	42.7 AV	54.0	-11.3	2.38 V	352	26.1	16.6

REMARKS:

1. Emission Level(dBuV/m) = Raw Value(dBuV) + Correction Factor(dB/m)
2. Correction Factor(dB/m) = Antenna Factor(dB/m) + Cable Factor(dB) – Pre-Amplifier Factor(dB)
3. The other emission levels were very low against the limit.
4. Margin value = Emission Level – Limit value
5. " * ": Fundamental frequency.
6. " # ": The radiated frequency is out of the restricted band.

Below 1GHz Data:

802.11ac (VHT20)

CHANNEL	TX Channel 140	DETECTOR FUNCTION	Quasi-Peak (QP)
FREQUENCY RANGE	9kHz ~ 1GHz		

ANTENNA POLARITY & TEST DISTANCE: HORIZONTAL AT 3 M

NO.	FREQ. (MHz)	EMISSION LEVEL (dBuV/m)	LIMIT (dBuV/m)	MARGIN (dB)	ANTENNA HEIGHT (m)	TABLE ANGLE (Degree)	RAW VALUE (dBuV)	CORRECTION FACTOR (dB/m)
1	88.35	33.2 QP	43.5	-10.3	2.00 H	360	47.4	-14.2
2	114.58	32.3 QP	43.5	-11.2	3.00 H	267	43.0	-10.7
3	223.90	32.4 QP	46.0	-13.6	1.00 H	56	43.5	-11.1
4	347.07	34.5 QP	46.0	-11.5	1.00 H	301	41.0	-6.5
5	396.83	37.4 QP	46.0	-8.6	3.00 H	187	42.8	-5.4
6	470.26	34.3 QP	46.0	-11.7	3.00 H	306	37.9	-3.6

ANTENNA POLARITY & TEST DISTANCE: VERTICAL AT 3 M

NO.	FREQ. (MHz)	EMISSION LEVEL (dBuV/m)	LIMIT (dBuV/m)	MARGIN (dB)	ANTENNA HEIGHT (m)	TABLE ANGLE (Degree)	RAW VALUE (dBuV)	CORRECTION FACTOR (dB/m)
1	37.69	36.0 QP	40.0	-4.0	1.00 V	152	44.8	-8.8
2	88.78	29.4 QP	43.5	-14.1	1.00 V	360	43.5	-14.1
3	114.54	34.2 QP	43.5	-9.3	1.00 V	360	44.9	-10.7
4	346.95	40.7 QP	46.0	-5.3	1.00 V	360	47.2	-6.5
5	388.58	39.8 QP	46.0	-6.2	1.00 V	52	45.5	-5.7
6	480.64	36.1 QP	46.0	-9.9	1.00 V	51	39.5	-3.4

REMARKS:

1. Emission Level(dBuV/m) = Raw Value(dBuV) + Correction Factor(dB/m)
2. Correction Factor(dB/m) = Antenna Factor(dB/m) + Cable Factor(dB) – Pre-Amplifier Factor(dB)
3. The other emission levels were very low against the limit.
4. Margin value = Emission Level – Limit value

4.2 Conducted Emission Measurement

4.2.1 Limits of Conducted Emission Measurement

Frequency (MHz)	Conducted Limit (dBuV)	
	Quasi-peak	Average
0.15 - 0.5	66 - 56	56 - 46
0.50 - 5.0	56	46
5.0 - 30.0	60	50

Note: 1. The lower limit shall apply at the transition frequencies.

2. The limit decreases in line with the logarithm of the frequency in the range of 0.15 to 0.50MHz.

4.2.2 Test Instruments

DESCRIPTION & MANUFACTURER	MODEL NO.	SERIAL NO.	CALIBRATED DATE	CALIBRATED UNTIL
Test Receiver R&S	ESCS 30	847124/029	Oct. 24, 2016	Oct. 23, 2017
Line-Impedance Stabilization Network (for EUT) R&S	ESH3-Z5	848773/004	Oct. 26, 2016	Oct. 25, 2017
Line-Impedance Stabilization Network (for Peripheral) R&S	ENV216	100072	June 03, 2017	June 02, 2018
50 ohms Terminator	N/A	EMC-02	Sep. 22, 2017	Sep. 21, 2018
RF Cable	5D-FB	COCCAB-001	Sep. 29, 2017	Sep. 28, 2018
10 dB PAD Mini-Circuits	HAT-10+	CONATT-004	June 18, 2017	June 17, 2018
Software BVADT	BVADT_Cond_ V7.3.7.4	NA	NA	NA

Note:

1. The calibration interval of the above test instruments are 12 months and the calibrations are traceable to NML/ROC and NIST/USA.
2. The test was performed in Shielded Room No. 1.
3. Tested Date: Oct. 04, 2017

4.2.3 Test Procedure

- The EUT was placed 0.4 meters from the conducting wall of the shielded room with EUT being connected to the power mains through a line impedance stabilization network (LISN). Other support units were connected to the power mains through another LISN. The two LISNs provide 50 ohm/ 50uH of coupling impedance for the measuring instrument.
- Both lines of the power mains connected to the EUT were checked for maximum conducted interference.
- The frequency range from 150kHz to 30MHz was searched. Emission levels under (Limit - 20dB) was not recorded.

NOTE: All modes of operation were investigated and the worst-case emissions are reported.

4.2.4 Deviation from Test Standard

No deviation.

4.2.5 Test Setup

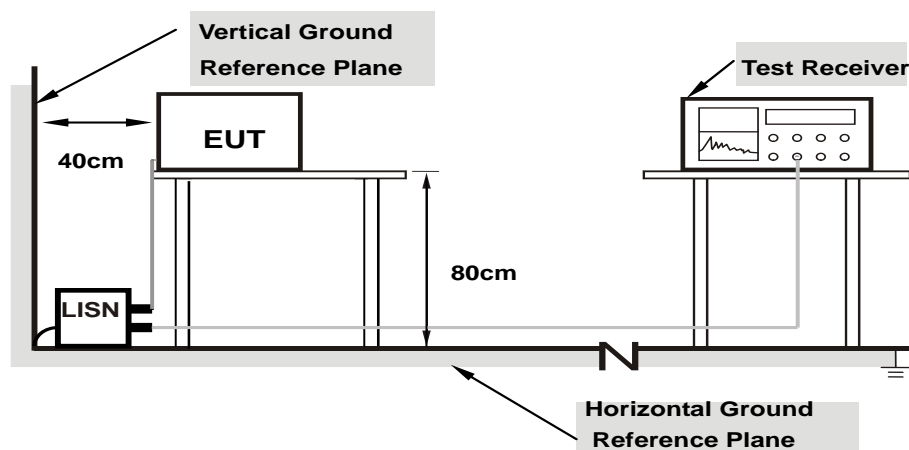

Note: 1.Support units were connected to second LISN.

For the actual test configuration, please refer to the attached file (Test Setup Photo).

4.2.6 EUT Operating Condition

Same as 4.1.6.

4.2.7 Test Results (Mode 1)

Phase	Line (L)	Detector Function	Quasi-Peak (QP) / Average (AV)
-------	----------	-------------------	--------------------------------

No	Freq. [MHz]	Corr.	Reading Value		Emission Level		Limit		Margin	
		Factor (dB)	[dB (uV)]		[dB (uV)]		[dB (uV)]		(dB)	
			Q.P.	AV.	Q.P.	AV.	Q.P.	AV.	Q.P.	AV.
1	0.16953	10.07	41.36	32.13	51.43	42.20	64.98	54.98	-13.55	-12.78
2	0.19297	10.06	30.00	11.88	40.06	21.94	63.91	53.91	-23.85	-31.97
3	0.24375	10.07	29.71	17.39	39.78	27.46	61.97	51.97	-22.19	-24.51
4	0.43125	10.11	29.00	20.14	39.11	30.25	57.23	47.23	-18.12	-16.98
5	16.97656	11.09	22.51	8.74	33.60	19.83	60.00	50.00	-26.40	-30.17
6	20.45703	11.29	23.31	9.52	34.60	20.81	60.00	50.00	-25.40	-29.19

REMARKS:

1. Q.P. and AV. are abbreviations of quasi-peak and average individually.
2. The emission levels of other frequencies were very low against the limit.
3. Margin value = Emission level - Limit value
4. Correction factor = Insertion loss + Cable loss
5. Emission Level = Correction Factor + Reading Value.

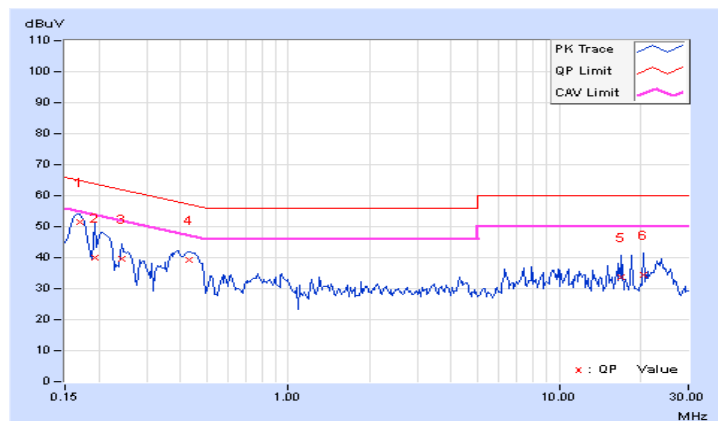

Phase	Neutral (N)	Detector Function	Quasi-Peak (QP) / Average (AV)
-------	-------------	-------------------	--------------------------------

No	Freq. [MHz]	Corr.	Reading Value		Emission Level		Limit		Margin	
		Factor	[dB (uV)]		[dB (uV)]		[dB (uV)]		(dB)	
	(dB)	Q.P.	AV.	Q.P.	AV.	Q.P.	AV.	Q.P.	AV.	
1	0.16953	10.05	41.30	31.77	51.35	41.82	64.98	54.98	-13.63	-13.16
2	0.20859	10.03	35.12	24.48	45.15	34.51	63.26	53.26	-18.11	-18.75
3	0.23984	10.04	26.33	11.01	36.37	21.05	62.10	52.10	-25.73	-31.05
4	0.42344	10.10	28.23	20.16	38.33	30.26	57.38	47.38	-19.05	-17.12
5	6.32031	10.35	22.85	21.20	33.20	31.55	60.00	50.00	-26.80	-18.45
6	24.10938	10.98	20.08	14.67	31.06	25.65	60.00	50.00	-28.94	-24.35

REMARKS:

1. Q.P. and AV. are abbreviations of quasi-peak and average individually.
2. The emission levels of other frequencies were very low against the limit.
3. Margin value = Emission level - Limit value
4. Correction factor = Insertion loss + Cable loss
5. Emission Level = Correction Factor + Reading Value.

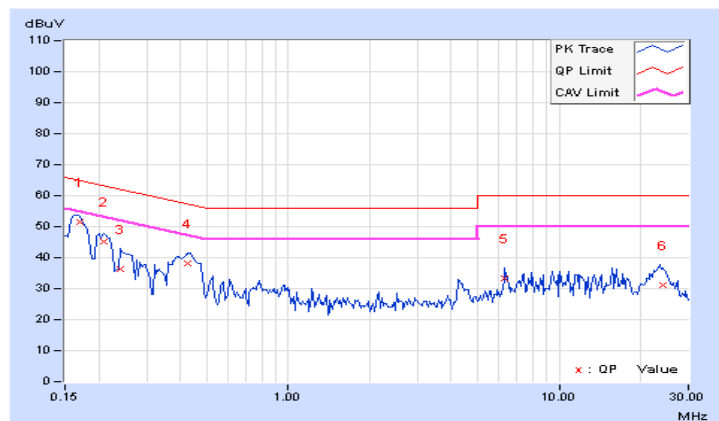

4.3 Transmit Power Measurement

4.3.1 Limits of Transmit Power Measurement

Operation Band	EUT Category		Limit
U-NII-1		Outdoor Access Point	1 Watt (30 dBm) (Max. e.i.r.p \leq 125mW(21 dBm) at any elevation angle above 30 degrees as measured from the horizon)
		Fixed point-to-point Access Point	1 Watt (30 dBm)
		Indoor Access Point	1 Watt (30 dBm)
		Mobile and Portable client device	250mW (24 dBm)
U-NII-2A		√	250mW (24 dBm) or 11 dBm+10 log B*
U-NII-2C		√	250mW (24 dBm) or 11 dBm+10 log B*
U-NII-3		√	1 Watt (30 dBm)

*B is the 26 dB emission bandwidth in megahertz

Per KDB 662911 Method of conducted output power measurement on IEEE 802.11 devices,

Array Gain = 0 dB (i.e., no array gain) for $N_{ANT} \leq 4$;

Array Gain = 0 dB (i.e., no array gain) for channel widths ≥ 40 MHz for any N_{ANT} ;

Array Gain = $5 \log(N_{ANT}/N_{SS})$ dB or 3 dB, whichever is less for 20-MHz channel widths with $N_{ANT} \geq 5$.

For power measurements on all other devices: Array Gain = $10 \log(N_{ANT}/N_{SS})$ dB.

4.3.2 Test Setup

FOR POWER OUTPUT MEASUREMENT

For channel straddling 5725MHz:

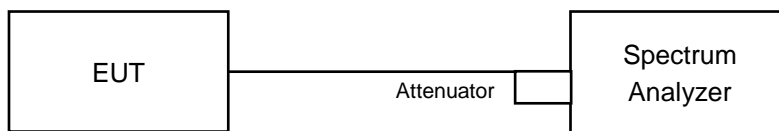

For other channels:

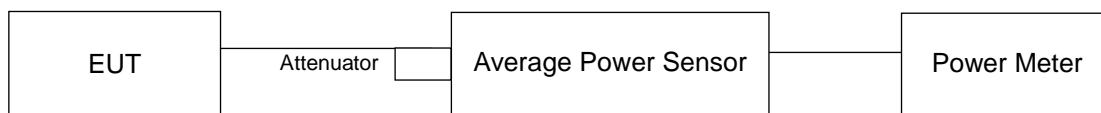

FOR 26dB OCCUPIED BANDWIDTH

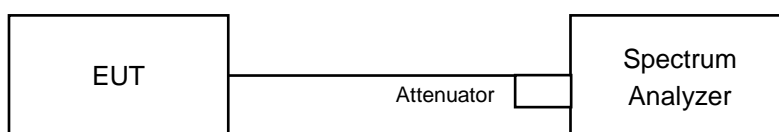

4.3.3 Test Instruments

Refer to section 4.1.2 to get information of above instrument.

4.3.4 Test Procedure

For Average Power Measurement

For channel straddling 5725MHz:

802.11ac (VHT80)

Method SA-2

1. Set span to encompass the emission bandwidth (EBW) of the signal.
2. Set RBW = 1MHz.
3. Set the VBW $\geq 3 \times$ RBW.
4. Number of points in sweep ≥ 2 Span / RBW.
5. Sweep time = auto.
6. Detector = RMS.
7. Trace average at least 100 traces in power averaging mode
8. Compute power by integrating the spectrum across the 26 dB EBW of the signal.
9. Duty factor need added to measured value (duty cycle < 98 percent).

Other Modulation mode

Method SA-1

1. Set span to encompass the entire emission bandwidth (EBW) of the signal.
2. Set RBW = 1MHz.
3. Set the VBW $\geq 3 \times$ RBW.
4. Number of points in sweep ≥ 2 Span / RBW.
5. Sweep time = auto.
6. Set trigger to free run (duty cycle ≥ 98 percent)
7. Detector = RMS.
8. Trace average at least 100 traces in power averaging mode
9. Compute power by integrating the spectrum across the 26 dB EBW of the signal.

For other channels:

Method PM is used to perform output power measurement, trigger and gating function of wide band power meter is enabled to measure max output power of TX on burst. Duty factor is not added to measured value.

FOR 26dB OCCUPIED BANDWIDTH

1. Set RBW = approximately 1% of the emission bandwidth.
2. Set the VBW > RBW.
3. Detector = Peak.
4. Trace mode = max hold.
5. Measure the maximum width of the emission that is 26 dB down from the peak of the emission. Compare this with the RBW setting of the analyzer. Readjust RBW and repeat measurement as needed until the RBW/EBW ratio is approximately 1%.

4.3.5 Deviation from Test Standard

No deviation.

4.3.6 EUT Operating Condition

The software provided by client to enable the EUT under transmission condition continuously at lowest, middle and highest channel frequencies individually.

4.3.7 Test Result (Mode 1)

CDD Mode

802.11a

Power Output:

Chan.	Chan. Freq. (MHz)	Maximum Conducted Power (dBm)				Total Power (mW)	Total Power (dBm)	Limit (dBm)	Pass / Fail
		Chain 0	Chain 1	Chain 2	Chain 3				
52	5260	12.88	13.02	12.22	12.73	74.876	18.74	24.00	Pass
60	5300	12.74	12.99	12.26	12.77	74.45	18.72	24.00	Pass
64	5320	12.76	13.12	12.33	12.62	74.773	18.74	24.00	Pass
100	5500	12.82	13.03	12.33	12.70	74.955	18.75	24.00	Pass
116	5580	12.79	13.10	12.22	12.72	74.807	18.74	24.00	Pass
140	5700	12.69	12.89	12.19	12.66	73.04	18.64	24.00	Pass
*144 (UNII-2C Band)	5720	8.93	8.87	8.59	9.17	31.013	14.92	22.97	Pass
*144 (UNII-3 Band)	5720	2.85	2.77	2.37	2.88	7.487	8.74	30.00	Pass

Note: * Test was performed in accordance with Measurement follow FCC KDB 789033 UNII test procedure Method SA-1 and use spectrum analyzer test.

The Total Power for the straddle channel:

Chan.	Chan. Freq. (MHz)	Average Power (mW)	Average Power (dBm)
144	5720	38.5	15.85

Note: The total power was calculated through formula and record the value for reference only.

26dB BANDWIDTH:

Channel	Frequency (MHz)	26dBc Bandwidth (MHz)			
		Chain 0	Chain 1	Chain 2	Chain 3
52	5260	21.76	21.55	21.61	21.49
60	5300	21.73	21.67	21.52	21.62
64	5320	21.67	21.71	21.67	21.62
100	5500	21.63	21.70	21.51	21.52
116	5580	21.73	21.80	21.51	21.59
140	5700	21.75	21.70	21.61	21.55
144 (UNII-2C Band)	5720	15.88	15.92	15.82	15.74

Note: For U_NII-2A, U_NII-2C Band output power limitation is determined based on 26dBc bandwidth.

Power Limit = 11dBm + 10logB < U_NII-2A, U_NII-2C >			
Channel Number	Freq.(MHz)	Min. B(MHz)	Determined Conducted Limit (dBm)
52	5260	21.49	24.32 > 24
60	5300	21.52	24.32 > 24
64	5320	21.62	24.34 > 24
100	5500	21.51	24.32 > 24
116	5580	21.51	24.32 > 24
140	5700	21.55	24.33 > 24
144 (UNII-2C Band)	5720	15.74	22.97 < 24

Beamforming Mode

802.11ac (VHT20)

POWER OUTPUT:

Chan.	Chan. Freq. (MHz)	Maximum Conducted Power (dBm)				Total Power (mW)	Total Power (dBm)	Limit (dBm)	Pass / Fail
		Chain 0	Chain 1	Chain 2	Chain 3				
52	5260	13.02	13.13	12.45	12.95	77.907	18.92	18.98	Pass
60	5300	13.01	13.03	12.37	13.05	77.532	18.89	18.98	Pass
64	5320	12.81	13.13	12.57	12.90	77.228	18.88	18.98	Pass
100	5500	13.03	12.27	12.69	13.02	75.58	18.78	18.98	Pass
116	5580	12.94	13.15	11.95	12.95	75.725	18.79	18.98	Pass
140	5700	13.10	13.31	12.14	13.16	78.915	18.97	18.98	Pass
*144 (UNII-2C Band)	5720	8.84	9.35	8.49	9.42	32.079	15.06	17.98	Pass
*144 (UNII-3 Band)	5720	3.12	3.61	2.85	3.60	8.566	9.33	24.98	Pass

Note: 1. * Test was performed in accordance with Measurement follow FCC KDB 789033 UNII test procedure Method SA-1 and use spectrum analyzer test.

2. For UNII-2A & UNII-2C: Directional gain = $5\text{dBi} + 10\log(4) = 11.02\text{dBi} > 6\text{dBi}$, so the power limit shall be reduced to "Determined Conducted Limit" $-(11.02-6)$.

3. For UNII-3: Directional gain = $5\text{dBi} + 10\log(4) = 11.02\text{dBi} > 6\text{dBi}$, so the power limit shall be reduced to $30-(11.02-6) = 24.98$.

The Total Power for the straddle channel:

Chan.	Chan. Freq. (MHz)	Average Power (mW)	Average Power (dBm)
144	5720	40.645	16.09

Note: The total power was calculated through formula and record the value for reference only.

26dB BANDWIDTH:

Channel	Frequency (MHz)	26dBc Bandwidth (MHz)			
		Chain 0	Chain 1	Chain 2	Chain 3
52	5260	22.03	21.96	21.90	21.80
60	5300	21.81	22.10	21.98	22.11
64	5320	22.04	22.00	21.94	21.98
100	5500	22.03	21.86	21.86	21.91
116	5580	22.01	22.10	21.93	21.94
140	5700	22.09	21.97	21.85	21.98
144 (UNII-2C Band)	5720	15.92	15.87	15.95	15.88

Note: For U_NII-2A, U_NII-2C Band output power limitation is determined based on 26dBc bandwidth.

Power Limit = 11dBm + 10logB < U_NII-2A, U_NII-2C >			
Channel Number	Freq.(MHz)	Min. B(MHz)	Determined Conducted Limit (dBm)
52	5260	21.80	24.38 > 24
60	5300	21.81	24.38 > 24
64	5320	21.94	24.41 > 24
100	5500	21.86	24.39 > 24
116	5580	21.93	24.41 > 24
140	5700	21.85	24.39 > 24
144 (UNII-2C Band)	5720	15.87	23 < 24

802.11ac (VHT40)

POWER OUTPUT:

Chan.	Chan. Freq. (MHz)	Maximum Conducted Power (dBm)				Total Power (mW)	Total Power (dBm)	Limit (dBm)	Pass / Fail
		Chain 0	Chain 1	Chain 2	Chain 3				
54	5270	13.10	13.32	12.34	12.89	78.489	18.95	18.98	Pass
62	5310	12.88	13.12	12.20	13.34	78.094	18.93	18.98	Pass
102	5510	13.03	13.20	12.12	12.60	75.474	18.78	18.98	Pass
110	5550	12.79	13.12	12.22	12.91	75.738	18.79	18.98	Pass
134	5670	12.88	13.02	12.21	12.88	75.497	18.78	18.98	Pass
*142 (UNII-2C Band)	5710	9.35	9.67	9.26	9.67	35.579	15.51	18.98	Pass
*142 (UNII-3 Band)	5710	-1.11	-0.74	-1.28	-0.91	3.1735	5.02	24.98	Pass

Note: 1. * Test was performed in accordance with Measurement follow FCC KDB 789033 UNII test procedure Method SA-1 and use spectrum analyzer test.

2. For UNII-2A & UNII-2C: Directional gain = $5\text{dBi} + 10\log(4) = 11.02\text{dBi} > 6\text{dBi}$, so the power limit shall be reduced to "Determined Conducted Limit" $-(11.02-6)$.

3. For UNII-3: Directional gain = $5\text{dBi} + 10\log(4) = 11.02\text{dBi} > 6\text{dBi}$, so the power limit shall be reduced to $30-(11.02-6) = 24.98$.

The Total Power for the straddle channel:

Chan.	Chan. Freq. (MHz)	Average Power (mW)	Average Power (dBm)
142	5710	38.7525	15.88

Note: The total power was calculated through formula and record the value for reference only.

26dB BANDWIDTH:

Channel	Frequency (MHz)	26dBc Bandwidth (MHz)			
		Chain 0	Chain 1	Chain 2	Chain 3
54	5270	41.50	41.22	41.52	41.69
62	5310	41.49	41.44	41.70	41.56
102	5510	41.34	41.70	41.38	41.58
110	5550	41.28	41.41	41.21	41.52
134	5670	41.59	41.80	41.77	41.31
142 (UNII-2C Band)	5710	35.62	35.75	35.57	35.74

Note: For U_NII-2A, U_NII-2C Band output power limitation is determined based on 26dBc bandwidth.

Power Limit = 11dBm + 10logB < U_NII-2A, U_NII-2C >			
Channel Number	Freq.(MHz)	Min. B(MHz)	Determined Conducted Limit (dBm)
54	5270	41.22	27.15 > 24
62	5310	41.44	27.17 > 24
102	5510	41.34	27.16 > 24
110	5550	41.21	27.15 > 24
134	5670	41.31	27.16 > 24
142 (UNII-2C Band)	5710	35.57	26.51 > 24

802.11ac (VHT80)

POWER OUTPUT:

Chan.	Chan. Freq. (MHz)	Maximum Conducted Power (dBm)				Total Power (mW)	Total Power (dBm)	Limit (dBm)	Pass / Fail
		Chain 0	Chain 1	Chain 2	Chain 3				
58	5290	12.99	12.53	12.12	12.89	73.56	18.67	18.98	Pass
106	5530	13.28	12.80	12.48	13.02	78.082	18.93	18.98	Pass
122	5610	13.20	12.89	12.56	13.06	78.607	18.95	18.98	Pass
*138 (UNII-2C Band)	5690	9.46	9.59	9.81	9.84	39.573	15.97	18.98	Pass
*138 (UNII-3 Band)	5690	-4.48	-4.45	-4.30	-4.25	1.5585	1.93	24.98	Pass

Note: 1. * Test was performed in accordance with Measurement follow FCC KDB 789033 UNII test procedure Method SA-2 and use spectrum analyzer test.

2. For UNII-2A & UNII-2C: Directional gain = $5\text{dBi} + 10\log(4) = 11.02\text{dBi} > 6\text{dBi}$, so the power limit shall be reduced to "Determined Conducted Limit" $-(11.02-6)$.

3. For UNII-3: Directional gain = $5\text{dBi} + 10\log(4) = 11.02\text{dBi} > 6\text{dBi}$, so the power limit shall be reduced to $30-(11.02-6) = 24.98$.

The Total Power for the straddle channel:

Chan.	Chan. Freq. (MHz)	Average Power (mW)	Average Power (dBm)
138	5690	41.1315	16.14

Note: The total power was calculated through formula and record the value for reference only.

26dB BANDWIDTH:

Channel	Frequency (MHz)	26dBc Bandwidth (MHz)			
		Chain 0	Chain 1	Chain 2	Chain 3
58	5290	82.50	82.83	82.19	82.46
106	5530	82.64	82.71	82.78	82.52
122	5610	83.29	82.66	82.99	82.77
138 (UNII-2C Band)	5690	76.20	76.25	76.18	76.36

Note: For U_NII-2A, U_NII-2C Band output power limitation is determined based on 26dBc bandwidth

Power Limit = 11dBm + 10logB < U_NII-2A, U_NII-2C >			
Channel Number	Freq.(MHz)	Min. B(MHz)	Determined Conducted Limit (dBm)
58	5290	82.19	30.14 > 24
106	5530	82.52	30.16 > 24
122	5610	82.66	30.17 > 24
138 (UNII-2C Band)	5690	76.18	29.81 > 24

Spectrum Plot of Worst Value

802.11a / Chain 3 - CH144 (UNII-2C Band)

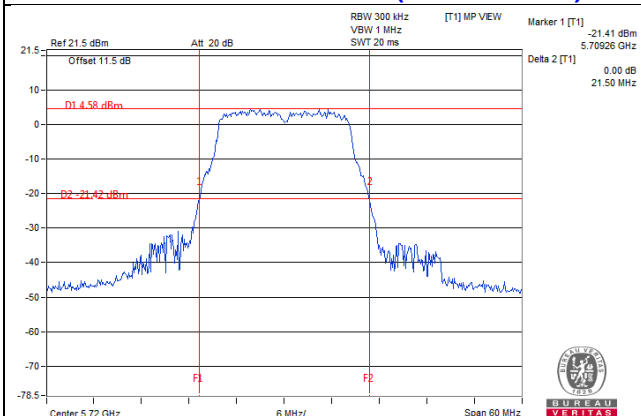

802.11ac (VHT20) / Chain 1 - CH144 (UNII-2C Band)

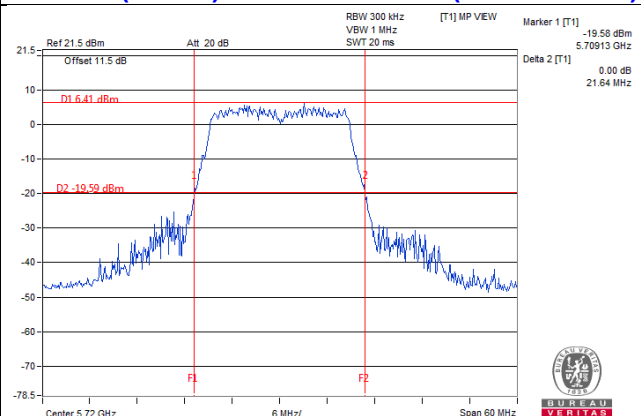

802.11ac (VHT40) / Chain 2 - CH142 (UNII-2C Band)

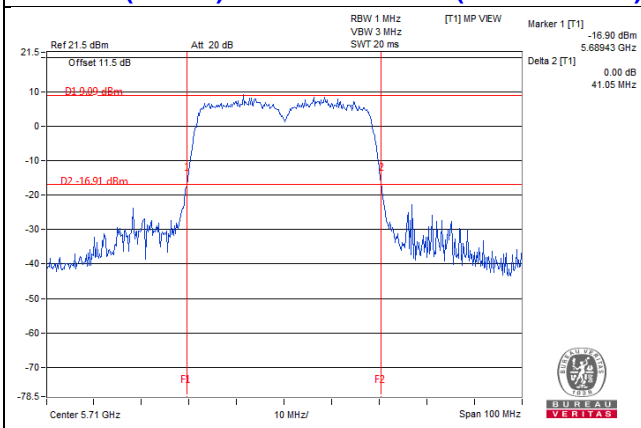

802.11ac (VHT80) / Chain 2 - CH138 (UNII-2C Band)

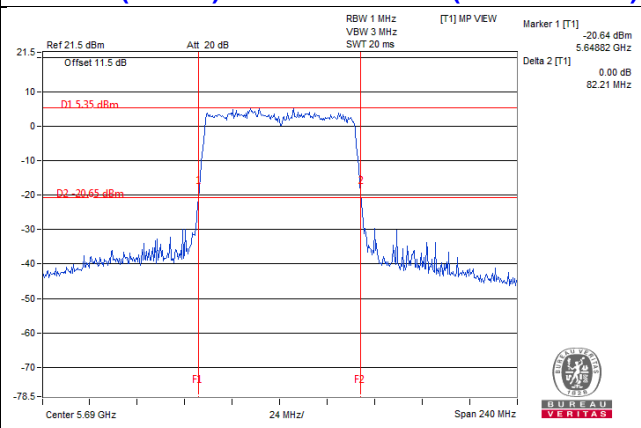

NOTE:

- For CH144 (UNII-2C Band) = 5725MHz - Marker 1
- For CH142 (UNII-2C Band) = 5725MHz - Marker 1
- For CH138 (UNII-2C Band) = 5725MHz - Marker 1

4.3.8 Test Result (Mode 2)

For UNII-2A:

CDD Mode

802.11a

Power Output:

Chan.	Chan. Freq. (MHz)	Maximum Conducted Power (dBm)			Total Power (mW)	Total Power (dBm)	Limit (dBm)	Pass / Fail
		Chain 0	Chain 2	Chain 3				
52	5260	15.57	14.94	15.44	102.242	20.10	24.00	Pass
60	5300	15.67	15.20	15.47	105.248	20.22	24.00	Pass
64	5320	15.47	15.13	15.46	102.977	20.13	24.00	Pass

26dB BANDWIDTH:

Channel	Frequency (MHz)	26dBc Bandwidth (MHz)		
		Chain 0	Chain 2	Chain 3
52	5260	21.68	21.74	21.61
60	5300	21.65	21.57	21.54
64	5320	21.82	21.57	21.64

Note: For U_NII-2A Band output power limitation is determined based on 26dBc bandwidth.

Power Limit = 11dBm + 10logB < U_NII-2A >			
Channel Number	Freq.(MHz)	Min. B(MHz)	Determined Conducted Limit (dBm)
52	5260	21.61	24.34 > 24
60	5300	21.54	24.33 > 24
64	5320	21.57	24.33 > 24

Beamforming Mode

802.11ac (VHT20)

POWER OUTPUT:

Chan.	Chan. Freq. (MHz)	Maximum Conducted Power (dBm)			Total Power (mW)	Total Power (dBm)	Limit (dBm)	Pass / Fail
		Chain 0	Chain 2	Chain 3				
52	5260	15.47	14.90	15.35	100.417	20.02	20.23	Pass
60	5300	15.49	14.95	15.40	101.335	20.06	20.23	Pass
64	5320	15.48	14.93	15.41	101.189	20.05	20.23	Pass

Note: 1. Directional gain = $5\text{dBi} + 10\log(3) = 9.77\text{dBi} > 6\text{dBi}$, so the power limit shall be reduced to "Determined Conducted Limit" $-(9.77-6)$.

26dB BANDWIDTH:

Channel	Frequency (MHz)	26dBc Bandwidth (MHz)		
		Chain 0	Chain 2	Chain 3
52	5260	21.91	21.86	21.91
60	5300	22.09	21.94	21.94
64	5320	21.92	22.05	21.96

Note: For U_NII-2A Band output power limitation is determined based on 26dBc bandwidth.

Power Limit = $11\text{dBm} + 10\log B < U_NII-2A >$			
Channel Number	Freq.(MHz)	Min. B(MHz)	Determined Conducted Limit (dBm)
52	5260	21.86	24.39 > 24
60	5300	21.94	24.41 > 24
64	5320	21.92	24.4 > 24

802.11ac (VHT40)

POWER OUTPUT:

Chan.	Chan. Freq. (MHz)	Maximum Conducted Power (dBm)			Total Power (mW)	Total Power (dBm)	Limit (dBm)	Pass / Fail
		Chain 0	Chain 2	Chain 3				
54	5270	15.45	14.84	15.40	100.228	20.01	20.23	Pass
62	5310	15.68	14.90	15.62	104.361	20.19	20.23	Pass

Note: 1. Directional gain = 5dBi + 10log(3) = 9.77dBi > 6dBi , so the power limit shall be reduced to "Determined Conducted Limit" -(9.77-6).

26dB BANDWIDTH:

Channel	Frequency (MHz)	26dBc Bandwidth (MHz)		
		Chain 0	Chain 2	Chain 3
54	5270	41.44	45.01	45.93
62	5310	41.54	41.44	41.39

Note: For U_NII-2A Band output power limitation is determined based on 26dBc bandwidth.

Power Limit = 11dBm + 10logB < U_NII-2A >			
Channel Number	Freq.(MHz)	Min. B(MHz)	Determined Conducted Limit (dBm)
54	5270	41.44	27.17 > 24
62	5310	41.39	27.16 > 24

802.11ac (VHT80)

POWER OUTPUT:

Chan.	Chan. Freq. (MHz)	Maximum Conducted Power (dBm)			Total Power (mW)	Total Power (dBm)	Limit (dBm)	Pass / Fail
		Chain 0	Chain 2	Chain 3				
58	5290	13.36	12.67	13.46	62.352	17.95	20.23	Pass

Note: 1. Directional gain = $5\text{dBi} + 10\log(3) = 9.77\text{dBi} > 6\text{dBi}$, so the power limit shall be reduced to "Determined Conducted Limit" $-(9.77-6)$.

26dB BANDWIDTH:

Channel	Frequency (MHz)	26dBc Bandwidth (MHz)		
		Chain 0	Chain 2	Chain 3
58	5290	82.86	82.61	82.64

Note: For U_NII-2A Band output power limitation is determined based on 26dBc bandwidth.

Power Limit = $11\text{dBm} + 10\log B < U_NII-2A >$			
Channel Number	Freq.(MHz)	Min. B(MHz)	Determined Conducted Limit (dBm)
58	5290	82.61	$30.17 > 24$

Spectrum Plot of Worst Value

802.11a / Chain 3 – CH60

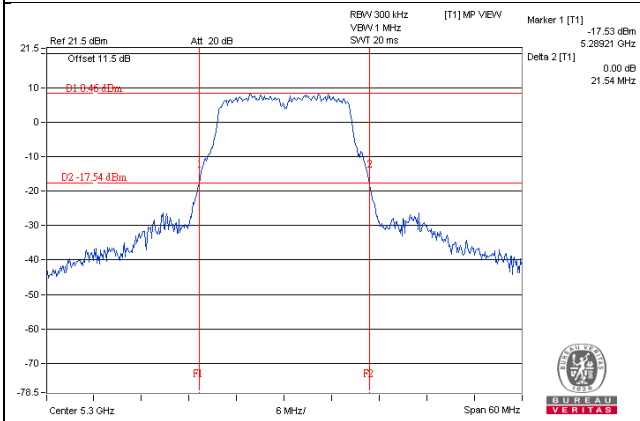

802.11ac (VHT20) / Chain 2- CH52

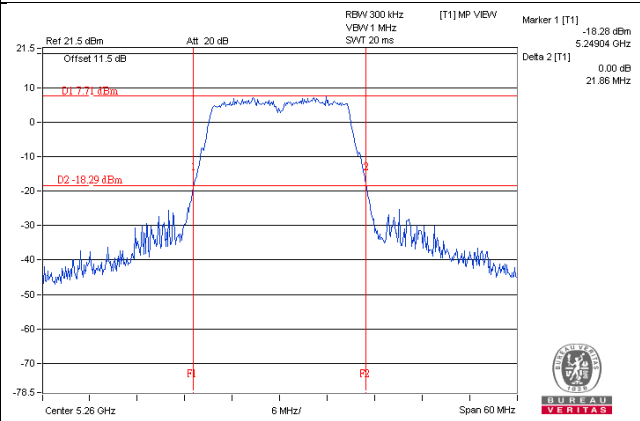

802.11ac (VHT40) / Chain 3 – CH62

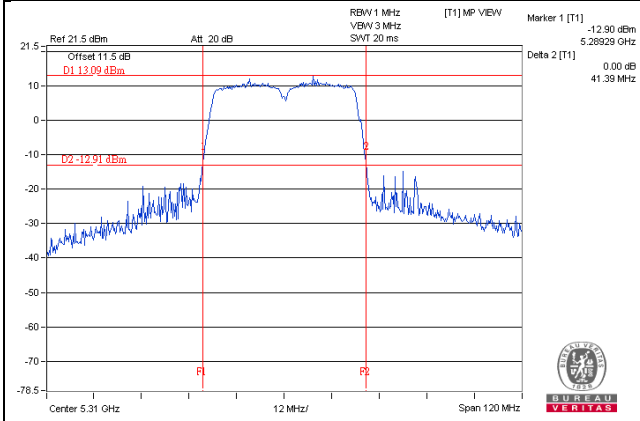

802.11ac (VHT80) / Chain 2 – CH58

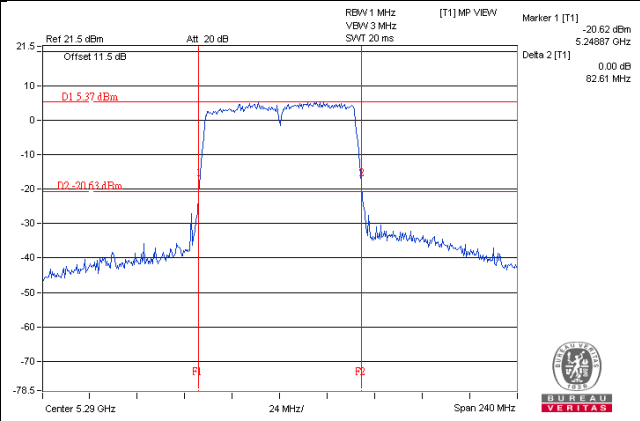

For UNII-2C:

CDD Mode

802.11a

Power Output:

Chan.	Chan. Freq. (MHz)	Maximum Conducted Power (dBm)			Total Power (mW)	Total Power (dBm)	Limit (dBm)	Pass / Fail
		Chain 1	Chain 2	Chain 3				
100	5500	15.65	15.10	15.56	105.062	20.21	24.00	Pass
116	5580	15.60	15.09	15.46	103.749	20.16	24.00	Pass
140	5700	15.65	15.10	15.59	105.311	20.22	24.00	Pass
*144 (UNII-2C Band)	5720	11.73	11.69	12.26	46.478	16.67	23.00	Pass
*144 (UNII-3 Band)	5720	5.78	5.49	5.93	11.241	10.51	30.00	Pass

Note: 1. * Test was performed in accordance with Measurement follow FCC KDB 789033 UNII test procedure Method SA-1 and use spectrum analyzer test.

The Total Power for the straddle channel:

Chan.	Chan. Freq. (MHz)	Average Power (mW)	Average Power (dBm)
144	5720	57.719	17.61

Note: The total power was calculated through formula and record the value for reference only.

26dB BANDWIDTH:

Channel	Frequency (MHz)	26dBc Bandwidth (MHz)		
		Chain 1	Chain 2	Chain 3
100	5500	21.61	21.48	21.41
116	5580	21.50	21.46	21.51
140	5700	21.76	21.62	21.62
144 (UNII-2C Band)	5720	15.90	15.92	15.87

Note: For U_NII-2C Band output power limitation is determined based on 26dBc bandwidth.

Power Limit = 11dBm + 10logB < U_NII-2C >			
Channel Number	Freq.(MHz)	Min. B(MHz)	Determined Conducted Limit (dBm)
100	5500	21.41	24.3 > 24
116	5580	21.46	24.31 > 24
140	5700	21.62	24.34 > 24
144 (UNII-2C Band)	5720	15.87	23 < 24

Beamforming Mode

802.11ac (VHT20)

POWER OUTPUT:

Chan.	Chan. Freq. (MHz)	Maximum Conducted Power (dBm)			Total Power (mW)	Total Power (dBm)	Limit (dBm)	Pass / Fail
		Chain 1	Chain 2	Chain 3				
100	5500	14.90	14.45	14.85	89.313	19.51	20.23	Pass
116	5580	14.91	14.35	14.83	88.61	19.47	20.23	Pass
140	5700	14.95	14.23	15.05	89.735	19.53	20.23	Pass
*144 (UNII-2C Band)	5720	10.62	11.29	11.22	38.237	15.82	19.24	Pass
*144 (UNII-3 Band)	5720	4.88	5.63	5.42	10.215	10.09	26.23	Pass

Note: 1. * Test was performed in accordance with Measurement follow FCC KDB 789033 UNII test procedure Method SA-1 and use spectrum analyzer test.

2. For UNII-2C: Directional gain = $5\text{dBi} + 10\log(3) = 9.77\text{dBi} > 6\text{dBi}$, so the power limit shall be reduced to "Determined Conducted Limit" $-(9.77-6)$.

3. For UNII-3: Directional gain = $5\text{dBi} + 10\log(3) = 9.77\text{dBi} > 6\text{dBi}$, so the power limit shall be reduced to $30-(9.77-6) = 26.23\text{dBm}$.

The Total Power for the straddle channel:

Chan.	Chan. Freq. (MHz)	Average Power (mW)	Average Power (dBm)
144	5720	48.452	16.85

Note: The total power was calculated through formula and record the value for reference only.

26dB BANDWIDTH:

Channel	Frequency (MHz)	26dBc Bandwidth (MHz)		
		Chain 1	Chain 2	Chain 3
100	5500	21.84	21.80	21.91
116	5580	22.01	22.06	21.85
140	5700	24.38	21.92	22.04
144 (UNII-2C Band)	5720	15.94	16.04	15.92

Note: For U_NII-2C Band output power limitation is determined based on 26dBc bandwidth.

Power Limit = 11dBm + 10logB < U_NII-2C >			
Channel Number	Freq.(MHz)	Min. B(MHz)	Determined Conducted Limit (dBm)
100	5500	21.80	24.38 > 24
116	5580	21.85	24.39 > 24
140	5700	21.92	24.4 > 24
144 (UNII-2C Band)	5720	15.92	23.01 < 24

802.11ac (VHT40)

POWER OUTPUT:

Chan.	Chan. Freq. (MHz)	Maximum Conducted Power (dBm)			Total Power (mW)	Total Power (dBm)	Limit (dBm)	Pass / Fail
		Chain 1	Chain 2	Chain 3				
102	5510	15.77	15.11	15.27	103.842	20.16	20.23	Pass
110	5550	15.60	15.23	15.20	102.764	20.12	20.23	Pass
134	5670	15.69	15.10	15.51	104.99	20.21	20.23	Pass
*142 (UNII-2C Band)	5710	12.15	11.97	12.66	50.596	17.04	20.23	Pass
*142 (UNII-3 Band)	5710	1.62	1.62	2.08	4.518	6.55	26.23	Pass

Note: 1. * Test was performed in accordance with Measurement follow FCC KDB 789033 UNII test procedure Method SA-1 and use spectrum analyzer test.

2. For UNII-2C: Directional gain = 5dBi + 10log(3) = 9.77dBi > 6dBi , so the power limit shall be reduced to "Determined Conducted Limit" -(9.77-6).

3. For UNII-3: Directional gain = 5dBi + 10log(3) = 9.77dBi > 6dBi , so the power limit shall be reduced to 30-(9.77-6) = 26.23dBm.

The Total Power for the straddle channel:

Chan.	Chan. Freq. (MHz)	Average Power (mW)	Average Power (dBm)
142	5710	55.114	17.41

Note: The total power was calculated through formula and record the value for reference only.

26dB BANDWIDTH:

Channel	Frequency (MHz)	26dBc Bandwidth (MHz)		
		Chain 1	Chain 2	Chain 3
102	5510	49.03	57.15	41.54
110	5550	50.95	41.65	41.52
134	5670	58.20	56.46	43.18
142 (UNII-2C Band)	5710	36.64	39.82	40.62

Note: For U_NII-2C Band output power limitation is determined based on 26dBc bandwidth.

Power Limit = 11dBm + 10logB < U_NII-2C >			
Channel Number	Freq.(MHz)	Min. B(MHz)	Determined Conducted Limit (dBm)
102	5510	41.54	27.18 > 24
110	5550	41.52	27.18 > 24
134	5670	43.18	27.35 > 24
142 (UNII-2C Band)	5710	36.64	26.63 > 24

802.11ac (VHT80)

POWER OUTPUT:

Chan.	Chan. Freq. (MHz)	Maximum Conducted Power (dBm)			Total Power (mW)	Total Power (dBm)	Limit (dBm)	Pass / Fail
		Chain 1	Chain 2	Chain 3				
106	5530	15.62	15.11	15.30	102.793	20.12	20.23	Pass
122	5610	15.70	15.22	15.32	104.461	20.19	20.23	Pass
*138 (UNII-2C Band)	5690	11.99	12.03	12.54	52.96	17.24	20.23	Pass
*138 (UNII-3 Band)	5690	-2.10	-1.68	-1.52	2.131	3.29	26.23	Pass

Note: 1. * Test was performed in accordance with Measurement follow FCC KDB 789033 UNII test procedure Method SA-2 and use spectrum analyzer test.

2. For UNII-2C: Directional gain = 5dBi + 10log(3) = 9.77dBi > 6dBi , so the power limit shall be reduced to "Determined Conducted Limit" -(9.77-6).

3. For UNII-3: Directional gain = 5dBi + 10log(3) = 9.77dBi > 6dBi , so the power limit shall be reduced to 30-(9.77-6) = 26.23dBm.

The Total Power for the straddle channel:

Chan.	Chan. Freq. (MHz)	Average Power (mW)	Average Power (dBm)
138	5690	55.091	17.41

Note: The total power was calculated through formula and record the value for reference only.

26dB BANDWIDTH:

Channel	Frequency (MHz)	26dBc Bandwidth (MHz)		
		Chain 1	Chain 2	Chain 3
106	5530	82.84	82.83	82.36
122	5610	82.72	82.87	82.94
138 (UNII-2C Band)	5690	76.43	76.31	76.13

Note: For U_NII-2C Band output power limitation is determined based on 26dBc bandwidth.

Power Limit = 11dBm + 10logB < U_NII-2C >			
Channel Number	Freq.(MHz)	Min. B(MHz)	Determined Conducted Limit (dBm)
106	5530	82.36	30.15 > 24
122	5610	82.72	30.17 > 24
138 (UNII-2C Band)	5690	76.13	29.81 > 24

Spectrum Plot of Worst Value

802.11a / Chain 3 - CH144 (UNII-2C Band)

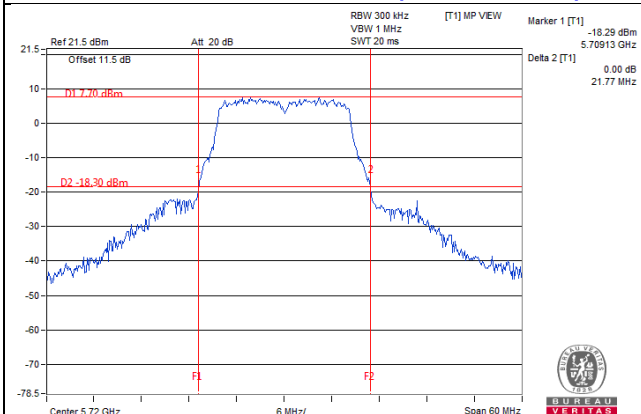

802.11ac (VHT20) / Chain 3 - CH144 (UNII-2C Band)

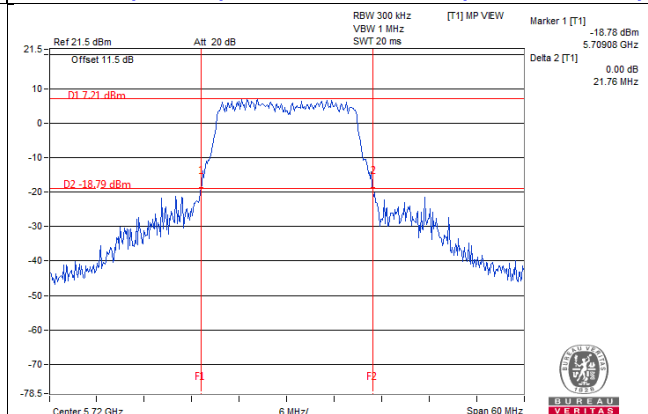

802.11ac (VHT40) / Chain 1 -CH142 (UNII-2C Band)

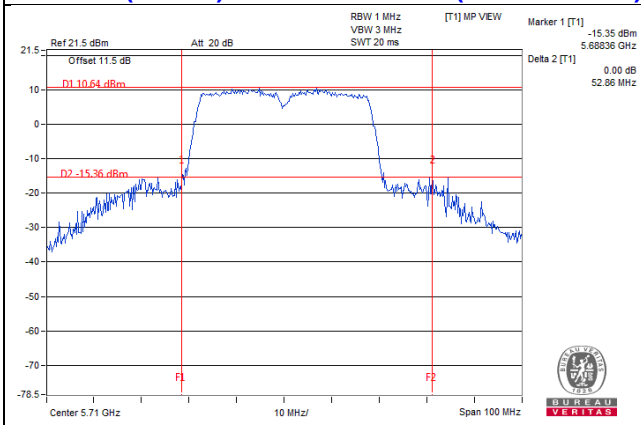

802.11ac (VHT80) / Chain 3 -CH138 (UNII-2C Band)

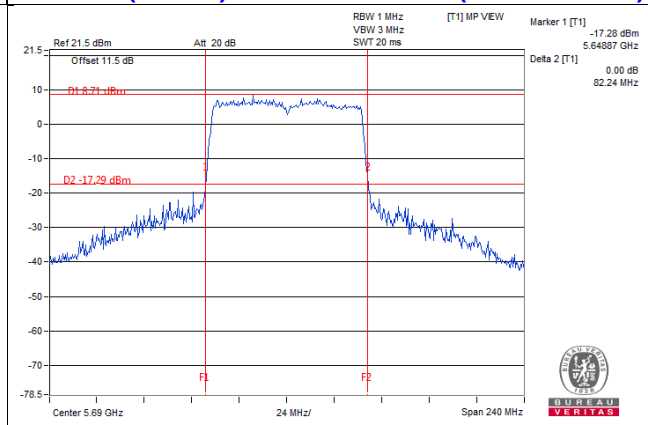

NOTE:

- For CH144 (UNII-2C Band) = 5725MHz - Marker 1
- For CH142 (UNII-2C Band) = 5725MHz - Marker 1
- For CH138 (UNII-2C Band) = 5725MHz - Marker 1

4.3.9 Test Result (Mode 3)

CDD Mode

802.11a

Power Output:

Chan.	Chan. Freq. (MHz)	Maximum Conducted Power (dBm)		Total Power (mW)	Total Power (dBm)	Limit (dBm)	Pass / Fail
		Chain 2	Chain 3				
52	5260	18.63	19.23	156.699	21.95	24.00	Pass
60	5300	18.59	19.22	155.837	21.93	24.00	Pass
64	5320	18.53	19.30	156.399	21.94	24.00	Pass
100	5500	18.48	19.03	150.452	21.77	24.00	Pass
116	5580	18.56	19.24	155.725	21.92	24.00	Pass
140	5700	18.63	19.22	156.699	21.95	24.00	Pass
*144 (UNII-2C Band)	5720	13.21	15.69	58.009	17.63	24.00	Pass
*144 (UNII-3 Band)	5720	6.41	9.36	13.005	11.14	30.00	Pass

Note: * Test was performed in accordance with Measurement follow FCC KDB 789033 UNII test procedure Method SA-1 and use spectrum analyzer test.

The Total Power for the straddle channel:

Chan.	Chan. Freq. (MHz)	Average Power (mW)	Average Power (dBm)
144	5720	71.014	18.51

Note: The total power was calculated through formula and record the value for reference only.

26dB BANDWIDTH:

Channel	Frequency (MHz)	26dBc Bandwidth (MHz)	
		Chain 2	Chain 3
52	5260	21.64	21.75
60	5300	21.69	22.03
64	5320	21.83	21.96
100	5500	21.92	21.83
116	5580	25.41	21.67
140	5700	32.26	24.94
144 (UNII-2C Band)	5720	21.24	22.55

Note: For U_NII-2A, U_NII-2C Band output power limitation is determined based on 26dBc bandwidth

Power Limit = 11dBm + 10logB < U_NII-2A, U_NII-2C >			
Channel Number	Freq.(MHz)	Min. B(MHz)	Determined Conducted Limit (dBm)
52	5260	21.64	24.35 > 24
60	5300	21.69	24.36 > 24
64	5320	21.83	24.39 > 24
100	5500	21.83	24.39 > 24
116	5580	21.67	24.35 > 24
140	5700	24.94	24.96 > 24
144 (UNII-2C Band)	5720	21.24	24.27 > 24

Beamforming Mode

802.11ac (VHT20)

POWER OUTPUT:

Chan.	Chan. Freq. (MHz)	Maximum Conducted Power (dBm)		Total Power (mW)	Total Power (dBm)	Limit (dBm)	Pass / Fail
		Chain 2	Chain 3				
52	5260	18.65	19.10	154.565	21.89	21.99	Pass
60	5300	18.66	19.02	153.25	21.85	21.99	Pass
64	5320	18.48	19.15	152.693	21.84	21.99	Pass
100	5500	18.55	19.12	153.272	21.85	21.99	Pass
116	5580	18.62	19.24	156.724	21.95	21.99	Pass
140	5700	18.56	19.10	153.062	21.85	21.99	Pass
*144 (UNII-2C Band)	5720	13.57	14.84	53.23	17.26	21.99	Pass
*144 (UNII-3 Band)	5720	7.93	9.17	14.469	11.60	27.99	Pass

Note: 1. * Test was performed in accordance with Measurement follow FCC KDB 789033 UNII test procedure Method SA-1 and use spectrum analyzer test.

2. For UNII-2A & UNII-2C: Directional gain = 5dBi + 10log(2) = 8.01dBi > 6dBi , so the power limit shall be reduced to "Determined Conducted Limit" -(8.01-6).

3. For UNII-3: Directional gain = Directional gain = 5dBi + 10log(2) = 8.01dBi > 6dBi , so the power limit shall be reduced to 30-(8.01-6) = 27.99dBm.

The Total Power for the straddle channel:

Chan.	Chan. Freq. (MHz)	Average Power (mW)	Average Power (dBm)
144	5720	67.699	18.31

Note: The total power was calculated through formula and record the value for reference only.

26dB BANDWIDTH:

Channel	Frequency (MHz)	26dBc Bandwidth (MHz)	
		Chain 2	Chain 3
52	5260	22.58	31.67
60	5300	31.47	29.75
64	5320	24.30	29.33
100	5500	34.40	31.15
116	5580	32.31	28.13
140	5700	33.71	34.30
144 (UNII-2C Band)	5720	24.46	22.78

Note: For U_NII-2A, U_NII-2C Band output power limitation is determined based on 26dBc bandwidth

Power Limit = 11dBm + 10logB < U_NII-2A, U_NII-2C >			
Channel Number	Freq.(MHz)	Min. B(MHz)	Determined Conducted Limit (dBm)
52	5260	22.58	24.53 > 24
60	5300	29.75	25.73 > 24
64	5320	24.30	24.85 > 24
100	5500	31.15	25.93 > 24
116	5580	28.13	25.49 > 24
140	5700	33.71	26.27 > 24
144 (UNII-2C Band)	5720	22.78	24.57 < 24

802.11ac (VHT40)

POWER OUTPUT:

Chan.	Chan. Freq. (MHz)	Maximum Conducted Power (dBm)		Total Power (mW)	Total Power (dBm)	Limit (dBm)	Pass / Fail
		Chain 2	Chain 3				
54	5270	18.63	19.23	156.699	21.95	21.99	Pass
62	5310	18.06	18.53	135.258	21.31	21.99	Pass
102	5510	18.60	19.22	156.004	21.93	21.99	Pass
110	5550	18.62	19.21	156.146	21.94	21.99	Pass
134	5670	18.66	19.15	155.675	21.92	21.99	Pass
*142 (UNII-2C Band)	5710	15.59	15.93	75.398	18.77	21.99	Pass
*142 (UNII-3 Band)	5710	5.24	5.36	6.778	8.31	27.99	Pass

Note: 1. * Test was performed in accordance with Measurement follow FCC KDB 789033 UNII test procedure Method SA-1 and use spectrum analyzer test.

2. For UNII-2A & UNII-2C: Directional gain = $5\text{dBi} + 10\log(2) = 8.01\text{dBi} > 6\text{dBi}$, so the power limit shall be reduced to "Determined Conducted Limit" $-(8.01-6)$.

3. For UNII-3: Directional gain = Directional gain = $5\text{dBi} + 10\log(2) = 8.01\text{dBi} > 6\text{dBi}$, so the power limit shall be reduced to $30-(8.01-6) = 27.99\text{dBm}$.

The Total Power for the straddle channel:

Chan.	Chan. Freq. (MHz)	Average Power (mW)	Average Power (dBm)
142	5710	82.176	19.15

Note: The total power was calculated through formula and record the value for reference only.

26dB BANDWIDTH:

Channel	Frequency (MHz)	26dBc Bandwidth (MHz)	
		Chain 2	Chain 3
54	5270	63.19	65.16
62	5310	69.47	65.46
102	5510	63.41	66.24
110	5550	68.63	65.76
134	5670	77.57	77.66
142 (UNII-2C Band)	5710	51.11	54.42

Note: For U_NII-2A, U_NII-2C Band output power limitation is determined based on 26dBc bandwidth

Power Limit = 11dBm + 10logB < U_NII-2A, U_NII-2C >			
Channel Number	Freq.(MHz)	Min. B(MHz)	Determined Conducted Limit (dBm)
54	5270	63.19	29 > 24
62	5310	65.46	29.15 > 24
102	5510	63.41	29.02 > 24
110	5550	65.76	29.17 > 24
134	5670	77.57	29.89 > 24
142 (UNII-2C Band)	5710	51.11	28.08 > 24

802.11ac (VHT80)

POWER OUTPUT:

Chan.	Chan. Freq. (MHz)	Maximum Conducted Power (dBm)		Total Power (mW)	Total Power (dBm)	Limit (dBm)	Pass / Fail
		Chain 2	Chain 3				
58	5290	17.76	18.37	128.411	21.09	21.99	Pass
106	5530	18.60	19.22	156.004	21.93	21.99	Pass
122	5610	17.72	19.78	154.216	21.88	21.99	Pass
*138 (UNII-2C Band)	5690	14.79	16.22	76.726	18.85	21.99	Pass
*138 (UNII-3 Band)	5690	0.96	2.05	3.037	4.82	27.99	Pass

Note: 1. * Test was performed in accordance with Measurement follow FCC KDB 789033 UNII test procedure Method SA-2 and use spectrum analyzer test.

2. For UNII-2A & UNII-2C: Directional gain = $5\text{dBi} + 10\log(2) = 8.01\text{dBi} > 6\text{dBi}$, so the power limit shall be reduced to "Determined Conducted Limit" $-(8.01-6)$.

3. For UNII-3: Directional gain = Directional gain = $5\text{dBi} + 10\log(2) = 8.01\text{dBi} > 6\text{dBi}$, so the power limit shall be reduced to $30-(8.01-6) = 27.99\text{dBm}$.

The Total Power for the straddle channel:

Chan.	Chan. Freq. (MHz)	Average Power (mW)	Average Power (dBm)
138	5690		

Note: The total power was calculated through formula and record the value for reference only.

26dB BANDWIDTH:

Channel	Frequency (MHz)	26dBc Bandwidth (MHz)	
		Chain 2	Chain 3
58	5290	83.21	87.96
106	5530	115.86	106.26
122	5610	93.16	137.36
138 (UNII-2C Band)	5690	82.28	93.75

Note: For U_NII-2A, U_NII-2C Band output power limitation is determined based on 26dBc bandwidth

Power Limit = 11dBm + 10logB < U_NII-2A, U_NII-2C >			
Channel Number	Freq.(MHz)	Min. B(MHz)	Determined Conducted Limit (dBm)
58	5290	83.21	30.2 > 24
106	5530	106.26	31.26 > 24
122	5610	93.16	30.69 > 24
138 (UNII-2C Band)	5690	82.28	30.15 > 24

Spectrum Plot of Worst Value

802.11a / Chain 2 –CH144 (UNII-2C Band)

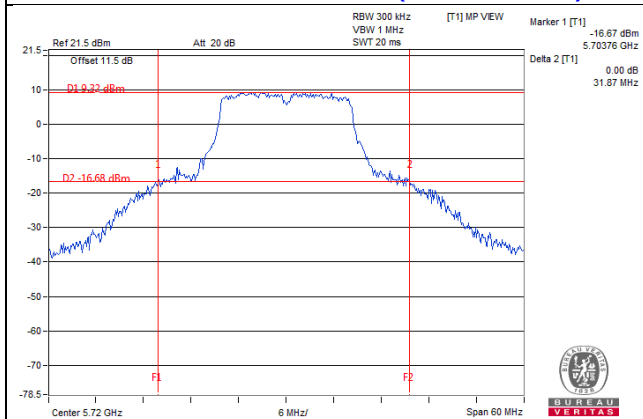

802.11ac (VHT20) / Chain 2 – CH52

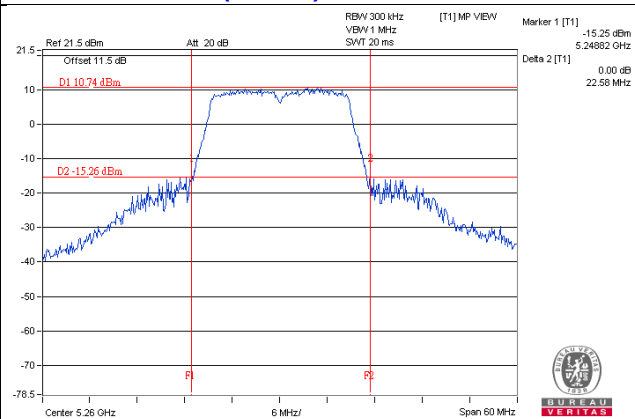

802.11ac (VHT40) / Chain 2 –CH142 (UNII-2C Band)

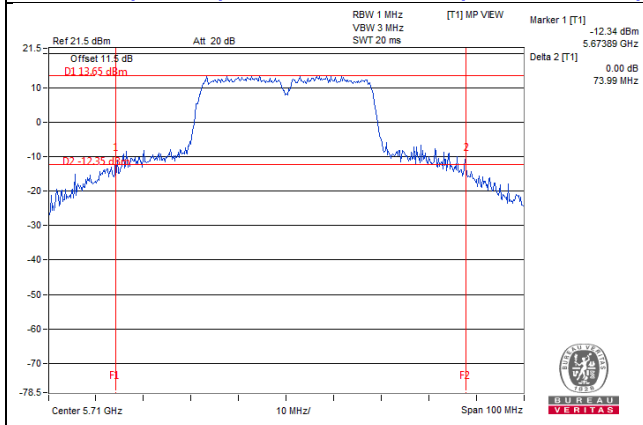

802.11ac (VHT80) / Chain 2 –CH138 (UNII-2C Band)

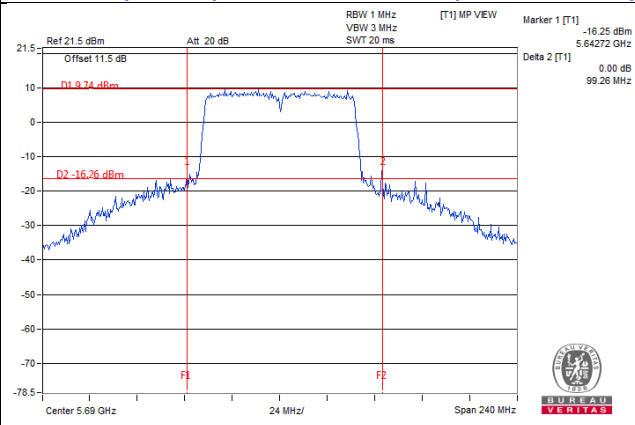

NOTE:

- For CH144 (UNII-2C Band) = 5725MHz - Marker 1
- For CH142 (UNII-2C Band) = 5725MHz - Marker 1
- For CH138 (UNII-2C Band) = 5725MHz - Marker 1

4.3.10 Test Result (Mode 4)

For U-NII-2A:

802.11a

Power Output:

Channel	Channel Frequency (MHz)	Maximum Conducted Power (mW)	Maximum Conducted Power (dBm)	Power Limit (dBm)	Pass/Fail
		Chain 3			
52	5260	247.742	23.94	24.00	Pass
60	5300	242.661	23.85	24.00	Pass
64	5320	122.18	20.87	24.00	Pass

26dB BANDWIDTH:

Channel	Frequency (MHz)	26dBc Bandwidth (MHz)
52	5260	37.32
60	5300	37.08
64	5320	32.17

Note: For U-NII-2A Band output power limitation is determined based on 26dBc bandwidth.

Power Limit = 11dBm + 10logB < U-NII-2A >			
Channel Number	Freq.(MHz)	Min. B(MHz)	Determined Conducted Limit (dBm)
52	5260	37.32	26.71 > 24
60	5300	37.08	26.69 > 24
64	5320	32.17	26.07 > 24

802.11ac (VHT20)

Power Output:

Channel	Channel Frequency (MHz)	Maximum Conducted Power (mW)	Maximum Conducted Power (dBm)	Power Limit (dBm)	Pass/Fail
		Chain 3			
52	5260	245.471	23.90	24.00	Pass
60	5300	248.886	23.96	24.00	Pass
64	5320	103.039	20.13	24.00	Pass

26dB BANDWIDTH:

Channel	Frequency (MHz)	26dBc Bandwidth (MHz)
52	5260	40.67
60	5300	40.01
64	5320	35.52

Note: For U-NII-2A Band output power limitation is determined based on 26dBc bandwidth.

Power Limit = 11dBm + 10logB < U-NII-2A >			
Channel Number	Freq.(MHz)	Min. B(MHz)	Determined Conducted Limit (dBm)
52	5260	40.67	27.09 > 24
60	5300	40.01	27.02 > 24
64	5320	35.52	26.5 > 24

802.11ac (VHT40)

Channel	Channel Frequency (MHz)	Maximum Conducted Power (mW)	Maximum Conducted Power (dBm)	Power Limit (dBm)	Pass/Fail
		Chain 3			
54	5270	239.332	23.79	24.00	Pass
62	5310	43.251	16.36	24.00	Pass

26dB BANDWIDTH:

Channel	Frequency (MHz)	26dBc Bandwidth (MHz)
54	5270	90.99
62	5310	41.49

Note: For U-NII-2A Band output power limitation is determined based on 26dBc bandwidth.

Power Limit = 11dBm + 10logB < U-NII-2A >			
Channel Number	Freq.(MHz)	Min. B(MHz)	Determined Conducted Limit (dBm)
54	5270	90.99	30.58 > 24
62	5310	41.49	27.17 > 24

802.11ac (VHT80)

Channel	Channel Frequency (MHz)	Maximum Conducted Power (mW)	Maximum Conducted Power (dBm)	Power Limit (dBm)	Pass/Fail
		Chain 3			
58	5290	34.514	15.38	24.00	Pass

26dB BANDWIDTH:

Channel	Frequency (MHz)	26dBc Bandwidth (MHz)
58	5290	82.59

Note: For U-NII-2A Band output power limitation is determined based on 26dBc bandwidth.

Power Limit = 11dBm + 10logB < U-NII-2A >			
Channel Number	Freq.(MHz)	Min. B(MHz)	Determined Conducted Limit (dBm)
58	5290	82.59	30.16 > 24

Spectrum Plot of Worst Value

802.11a / CH64

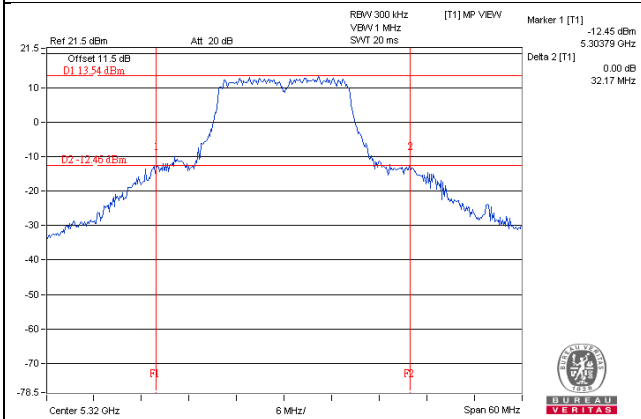

802.11ac (VHT20) / CH64

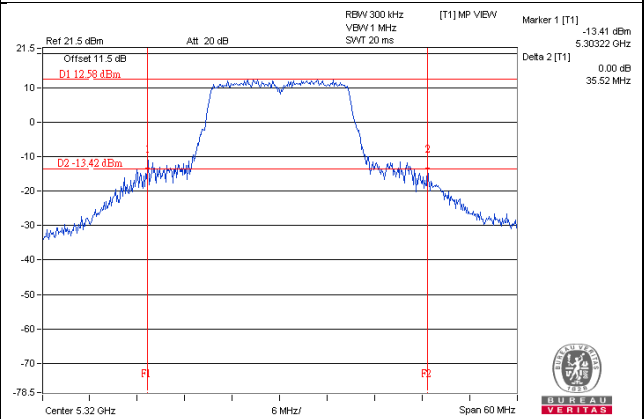

802.11ac (VHT40) / CH62

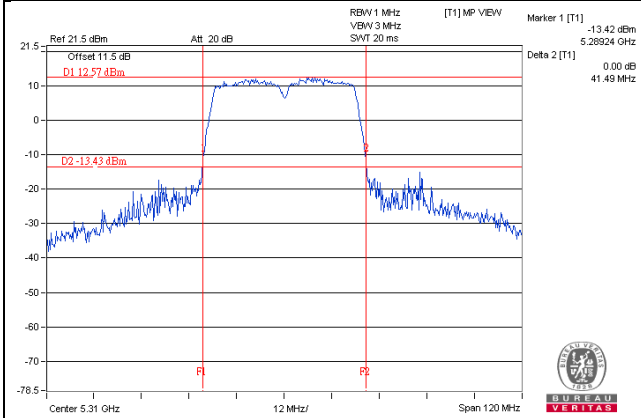

802.11ac (VHT80) / CH58

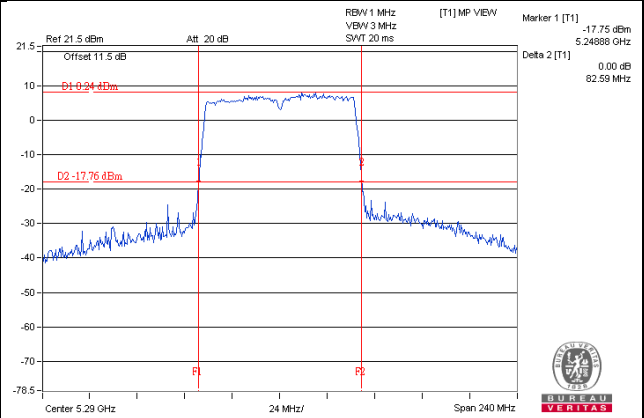

For U-NII-2C:

802.11a

Power Output:

Channel	Channel Frequency (MHz)	Maximum Conducted Power (mW)	Maximum Conducted Power (dBm)	Power Limit (dBm)	Pass/Fail
		Chain 2			
100	5500	117.49	20.70	24.00	Pass
116	5580	146.218	21.65	24.00	Pass
140	5700	88.92	19.49	24.00	Pass
*144 (UNII-2C)	5720	21.429	13.31	24.00	Pass
*144 (UNII-3 Band)	5720	5.14	7.11	30.00	Pass

Note: 1. * Test was performed in accordance with Measurement follow FCC KDB 789033 UNII test procedure Method SA-1 and use spectrum analyzer test.

The Total Power for the straddle channel:

Chan.	Chan. Freq. (MHz)	Average Power (mW)	Average Power (dBm)
144	5720	26.569	14.24

Note: The total power was calculated through formula and record the value for reference only.

26dB BANDWIDTH:

Channel	Frequency (MHz)	26dBc Bandwidth (MHz)
100	5500	35.82
116	5580	37.16
140	5700	36.90
144 (UNII-2C Band)	5720	20.04

Note: For U-NII-2C Band output power limitation is determined based on 26dBc bandwidth.

Power Limit = 11dBm + 10logB < U-NII-2C >			
Channel Number	Freq.(MHz)	Min. B(MHz)	Determined Conducted Limit (dBm)
100	5500	35.82	26.54 > 24
116	5580	37.16	26.7 > 24
140	5700	36.90	26.67 > 24
144 (UNII-2C Band)	5720	20.04	24.01 > 24

802.11ac (VHT20)

Power Output:

Channel	Channel Frequency (MHz)	Maximum Conducted Power (mW)	Maximum Conducted Power (dBm)	Power Limit (dBm)	Pass/Fail
		Chain 2			
100	5500	114.815	20.60	24.00	Pass
116	5580	145.881	21.64	24.00	Pass
140	5700	69.183	18.40	24.00	Pass
*144 (UNII-2C Band)	5720	19.454	12.89	24.00	Pass
*144 (UNII-3 Band)	5720	5.458	7.37	30.00	Pass

Note: 1. * Test was performed in accordance with Measurement follow FCC KDB 789033 UNII test procedure Method SA-1 and use spectrum analyzer test.

The Total Power for the straddle channel:

Chan.	Chan. Freq. (MHz)	Average Power (mW)	Average Power (dBm)
144	5720	24.912	13.96

Note: The total power was calculated through formula and record the value for reference only.

26dB BANDWIDTH:

Channel	Frequency (MHz)	26dBc Bandwidth (MHz)
100	5500	40.57
116	5580	40.50
140	5700	35.25
144 (UNII-2C Band)	5720	21.91

Note: For U-NII-2C Band output power limitation is determined based on 26dBc bandwidth.

Power Limit = 11dBm + 10logB < U-NII-2C >			
Channel Number	Freq.(MHz)	Min. B(MHz)	Determined Conducted Limit (dBm)
100	5500	40.57	27.08 > 24
116	5580	40.50	27.07 > 24
140	5700	35.25	26.47 > 24
144 (UNII-2C Band)	5720	21.91	24.4 > 24

802.11ac (VHT40)

Channel	Channel Frequency (MHz)	Maximum Conducted Power (mW)	Maximum Conducted Power (dBm)	Power Limit (dBm)	Pass/Fail
		Chain 2			
102	5510	57.81	17.62	24.00	Pass
110	5550	218.273	23.39	24.00	Pass
134	5670	86.298	19.36	24.00	Pass
*142 (UNII-2C Band)	5710	22.439	13.51	24.00	Pass
*142 (UNII-3 Band)	5710	2.104	3.23	30.00	Pass

Note: 1. * Test was performed in accordance with Measurement follow FCC KDB 789033 UNII test procedure Method SA-1 and use spectrum analyzer test.

The Total Power for the straddle channel:

Chan.	Chan. Freq. (MHz)	Average Power (mW)	Average Power (dBm)
142	5710	24.543	13.9

Note: The total power was calculated through formula and record the value for reference only.

26dB BANDWIDTH:

Channel	Frequency (MHz)	26dBc Bandwidth (MHz)
102	5510	63.88
110	5550	85.46
134	5670	80.28
142 (UNII-2C Band)	5710	55.55

Note: For U-NII-2C Band output power limitation is determined based on 26dBc bandwidth.

Power Limit = 11dBm + 10logB < U-NII-2A, U-NII-2C >			
Channel Number	Freq.(MHz)	Min. B(MHz)	Determined Conducted Limit (dBm)
102	5510	63.88	29.05 > 24
110	5550	85.46	30.31 > 24
134	5670	80.28	30.04 > 24
142 (UNII-2C Band)	5710	55.55	28.44 > 24

802.11ac (VHT80)

Channel	Channel Frequency (MHz)	Maximum Conducted Power (mW)	Maximum Conducted Power (dBm)	Power Limit (dBm)	Pass/Fail
		Chain 2			
106	5530	58.614	17.68	24.00	Pass
122	5610	123.027	20.90	24.00	
*138 (UNII-2C Band)	5690	20.675	13.15	24.00	Pass
*138 (UNII-3 Band)	5690	0.9451	-0.25	30.00	Pass

Note: 1. * Test was performed in accordance with Measurement follow FCC KDB 789033 UNII test procedure Method SA-2 and use spectrum analyzer test.

The Total Power for the straddle channel:

Chan.	Chan. Freq. (MHz)	Average Power (mW)	Average Power (dBm)
138	5690	21.6201	13.35

Note: The total power was calculated through formula and record the value for reference only.

26dB BANDWIDTH:

Channel	Frequency (MHz)	26dBc Bandwidth (MHz)
106	5530	82.72
122	5610	125.07
138 (UNII-2C Band)	5690	120.98

Note: For U-NII-2C Band output power limitation is determined based on 26dBc bandwidth.

Power Limit = 11dBm + 10logB < U-NII-2C >			
Channel Number	Freq.(MHz)	Min. B(MHz)	Determined Conducted Limit (dBm)
106	5530	82.72	30.17 > 24
122	5610	125.07	31.97 > 24
138 (UNII-2C Band)	5690	120.98	31.82 > 24

Spectrum Plot of Worst Value

802.11a / CH144 (UNII-2C Band)

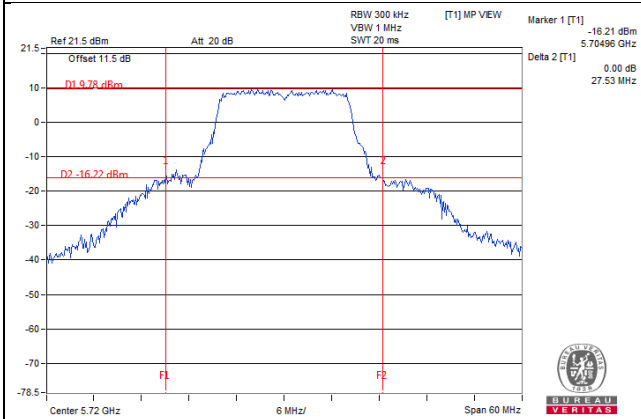

802.11ac (VHT20) / CH144 (UNII-2C Band)

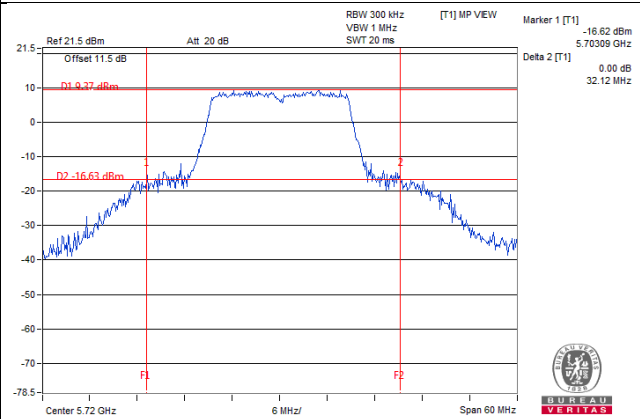

802.11ac (VHT40) / CH142 (UNII-2C Band)

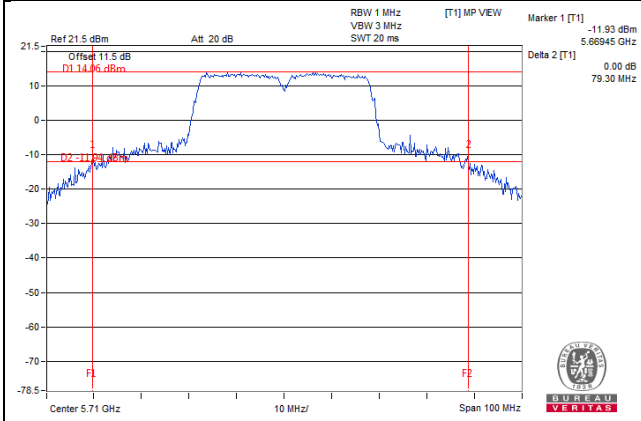

802.11ac (VHT80) / CH106

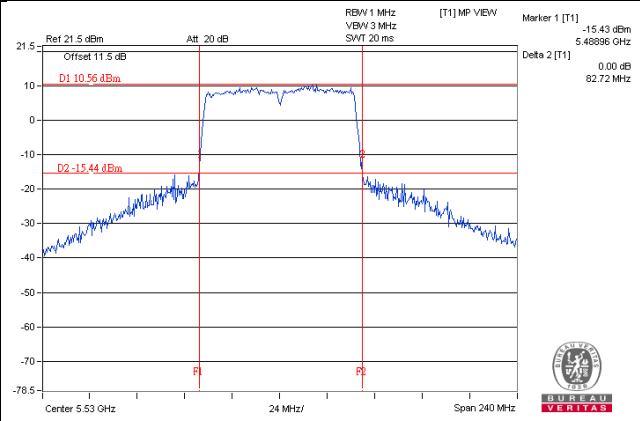

NOTE:

For CH144 (UNII-2C Band) = 5725MHz - Marker 1
 For CH142 (UNII-2C Band) = 5725MHz - Marker 1

4.4 Occupied Bandwidth Measurement

4.4.1 Test Setup

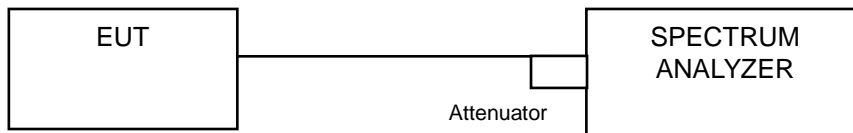

4.4.2 Test Instruments

Refer to section 4.1.2 to get information of above instrument.

4.4.3 Test Procedure

The transmitter output was connected to the spectrum analyzer through an attenuator. The bandwidth of the fundamental frequency was measured by spectrum analyzer with resolution bandwidth in the range of 1% to 5% of the anticipated emission bandwidth, and a video bandwidth at least 3x the resolution bandwidth and set the detector to SAMPLE. The width of a frequency band such that, below the lower and above the upper frequency limits, the mean powers emitted are each equal to a specified percentage 0.5 %of the total mean power of a given emission.

4.4.4 Test Results (Mode 1)

802.11a

Channel	Channel Frequency (MHz)	Occupied Bandwidth (MHz)			
		Chain 0	Chain 1	Chain 2	Chain 3
52	5260	16.92	17.04	16.92	16.92
60	5300	16.92	16.92	16.92	16.80
64	5320	16.92	16.92	16.92	16.92
100	5500	17.04	16.92	17.04	16.92
116	5580	17.04	16.92	16.92	16.80
140	5700	16.92	16.80	16.92	16.68
144 (UNII-2C Band)	5720	13.64	13.52	13.52	13.52
144 (UNII-3 Band)	5720	3.40	3.40	3.28	3.40

802.11ac (VHT20)

Channel	Channel Frequency (MHz)	Occupied Bandwidth (MHz)			
		Chain 0	Chain 1	Chain 2	Chain 3
52	5260	18.00	18.12	18.12	18.00
60	5300	17.88	18.24	18.00	18.00
64	5320	18.12	18.12	18.12	18.12
100	5500	18.00	18.00	18.12	18.00
116	5580	18.12	17.88	18.00	18.12
140	5700	18.00	17.88	18.00	18.12
144 (UNII-2C Band)	5720	14.12	14.00	14.00	14.12
144 (UNII-3 Band)	5720	4.00	4.00	3.88	4.00

802.11ac (VHT40)

Channel	Channel Frequency (MHz)	Occupied Bandwidth (MHz)			
		Chain 0	Chain 1	Chain 2	Chain 3
54	5270	36.96	36.72	36.96	36.72
62	5310	36.72	36.72	36.72	36.72
102	5510	36.72	36.72	36.72	36.72
110	5550	36.72	36.72	36.72	36.72
134	5670	36.72	36.72	36.48	36.72
142 (UNII-2C Band)	5710	33.60	33.40	33.60	33.60
142 (UNII-3 Band)	5710	3.20	3.20	3.20	3.20

802.11ac (VHT80)

Channel	Channel Frequency (MHz)	Occupied Bandwidth (MHz)			
		Chain 0	Chain 1	Chain 2	Chain 3
58	5290	76.32	75.84	75.84	75.84
106	5530	75.84	75.84	75.84	75.84
122	5610	76.32	76.32	75.84	76.32
138 (UNII-2C Band)	5690	73.40	73.40	73.40	72.92
138 (UNII-3 Band)	5690	2.44	2.92	2.44	2.44

Spectrum Plot of Worst Value

802.11a_Chain 0 / CH100

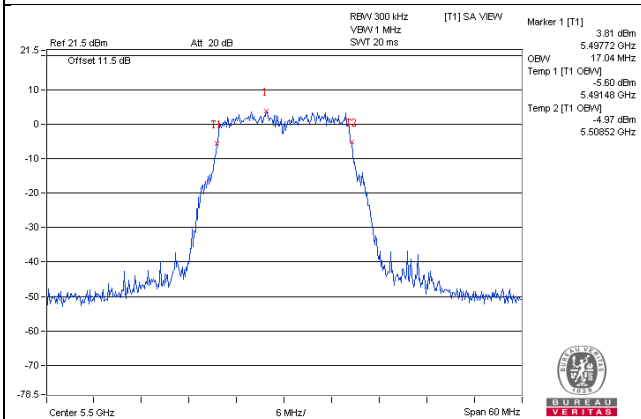

802.11ac (VHT20)_Chain 1 / CH60

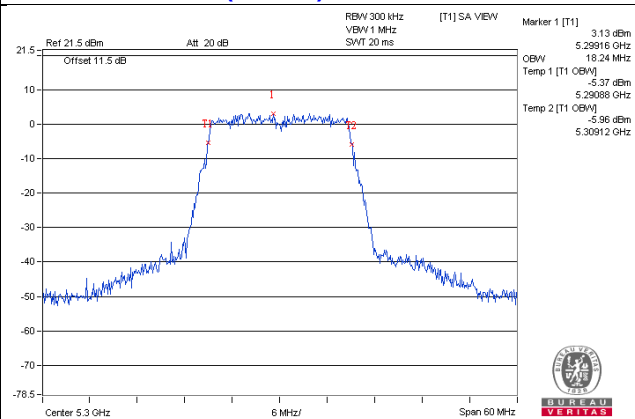

802.11ac (VHT40)_Chain 0 / CH54

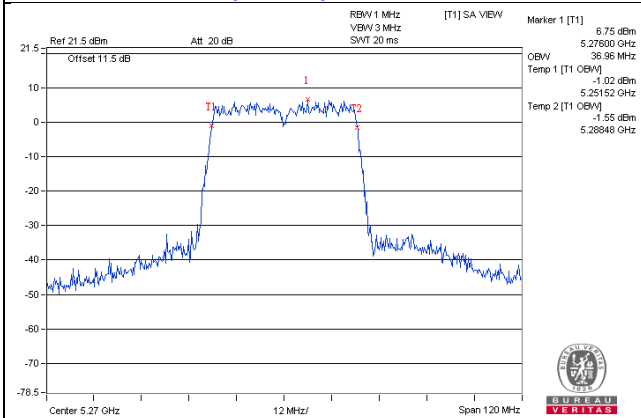

802.11ac (VHT80)_Chain 0 / CH58

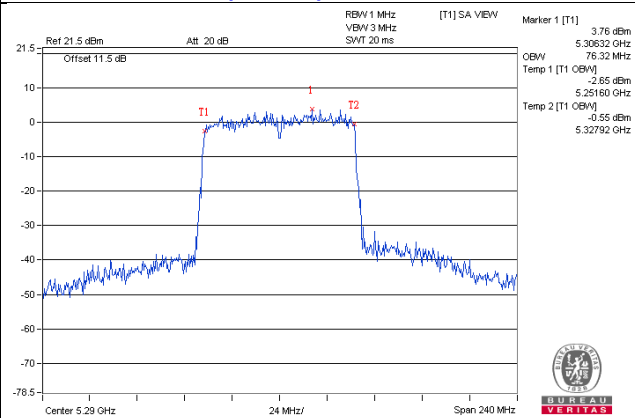

4.4.5 Test Results (Mode 2)

For U-NII-2A:

802.11a

Channel	Channel Frequency (MHz)	Occupied Bandwidth (MHz)		
		CHAIN 0	CHAIN 2	CHAIN 3
52	5260	16.92	16.92	16.80
60	5300	17.04	16.92	16.92
64	5320	16.92	16.92	16.92

802.11ac (VHT20)

Channel	Channel Frequency (MHz)	Occupied Bandwidth (MHz)		
		CHAIN 0	CHAIN 2	CHAIN 3
52	5260	18.00	18.00	18.00
60	5300	18.12	18.00	17.88
64	5320	17.88	18.12	18.00

802.11ac (VHT40)

Channel	Channel Frequency (MHz)	Occupied Bandwidth (MHz)		
		CHAIN 0	CHAIN 2	CHAIN 3
54	5270	36.48	36.48	36.48
62	5310	36.72	36.72	36.72

802.11ac (VHT80)

Channel	Channel Frequency (MHz)	Occupied Bandwidth (MHz)		
		CHAIN 0	CHAIN 2	CHAIN 3
58	5290	75.84	75.84	75.84

Spectrum Plot of Worst Value

802.11a_Chain0 / CH60

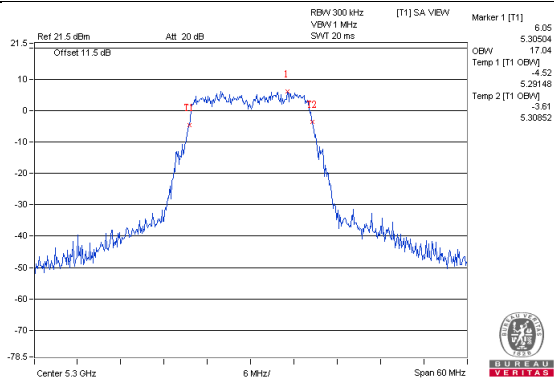

802.11ac (VHT20)_Chain0 / CH60

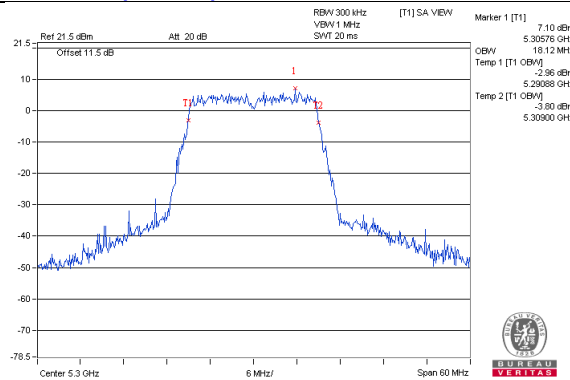

802.11ac (VHT40)_Chain0 / CH62

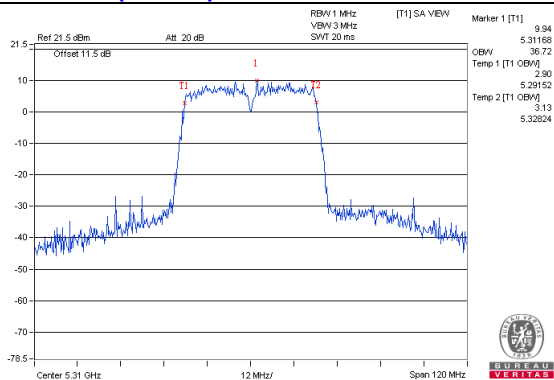

802.11ac (VHT80)_Chain0 / CH58

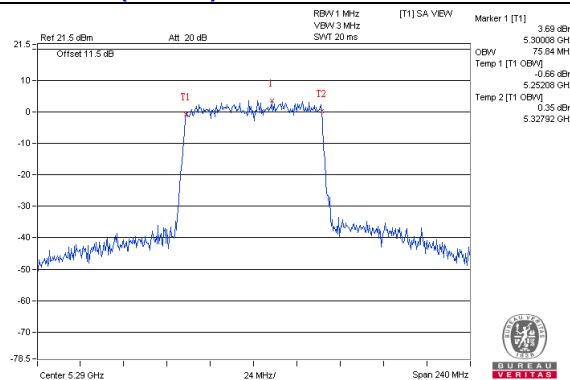

For U-NII-2C:
802.11a

Channel	Channel Frequency (MHz)	Occupied Bandwidth (MHz)		
		CHAIN 1	CHAIN 2	CHAIN 3
100	5500	16.80	16.92	16.92
116	5580	17.04	16.92	16.92
140	5700	16.92	16.92	16.92
144 (UNII-2C Band)	5720	13.52	13.52	13.64
144 (UNII-3 Band)	5720	3.40	3.40	3.40

802.11ac (VHT20)

Channel	Channel Frequency (MHz)	Occupied Bandwidth (MHz)		
		CHAIN 1	CHAIN 2	CHAIN 3
100	5500	18.00	18.00	18.00
116	5580	18.12	18.12	18.00
140	5700	18.12	18.24	18.00
144 (UNII-2C Band)	5710	14.12	14.12	14.12
144 (UNII-3 Band)	5710	4.00	3.88	4.00

802.11ac (VHT40)

Channel	Channel Frequency (MHz)	Occupied Bandwidth (MHz)		
		CHAIN 1	CHAIN 2	CHAIN 3
102	5510	36.72	36.96	36.72
110	5550	36.72	36.72	36.72
134	5670	36.72	36.72	36.72
142 (UNII-2C Band)	5710	33.60	33.40	33.60
142 (UNII-3 Band)	5710	3.20	3.20	3.40

802.11ac (VHT80)

Channel	Channel Frequency (MHz)	Occupied Bandwidth (MHz)		
		CHAIN 1	CHAIN 2	CHAIN 3
106	5530	76.32	76.32	75.84
122	5610	76.32	76.32	76.32
138 (UNII-2C Band)	5690	73.40	73.40	72.92
138 (UNII-3 Band)	5690	2.44	2.92	2.92

Spectrum Plot of Worst Value

802.11a_Chain1 / CH116

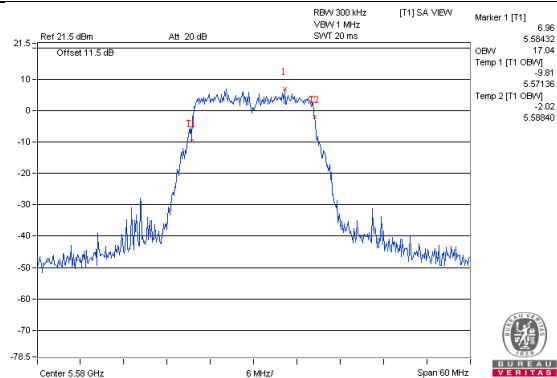

802.11ac (VHT20)_Chain2 / CH140

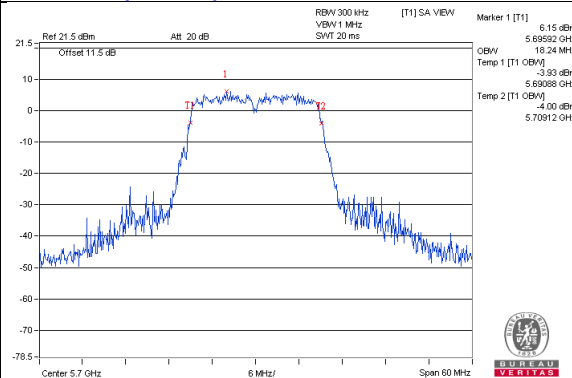

802.11ac (VHT40)_Chain2 / CH102

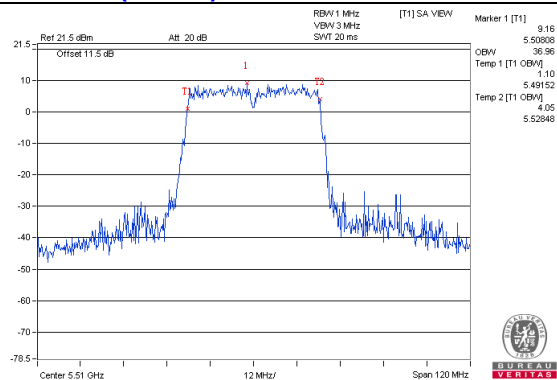

802.11ac (VHT80)_Chain1 / CH106

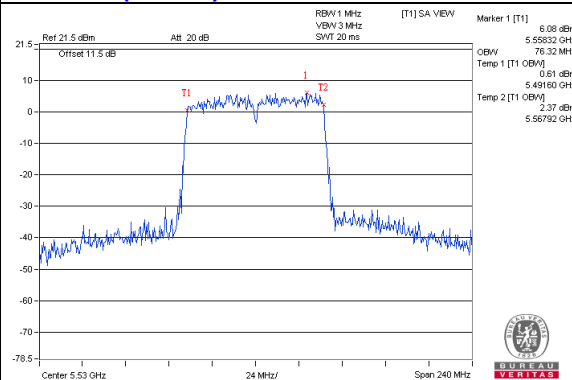

4.4.6 Test Results (Mode 3)

802.11a

Channel	Channel Frequency (MHz)	Occupied Bandwidth (MHz)	
		CHAIN 2	CHAIN 3
52	5260	16.92	17.04
60	5300	16.92	17.04
64	5320	16.92	16.92
100	5500	17.04	16.92
116	5580	17.04	17.04
140	5700	17.28	16.92
144 (UNII-2C Band)	5720	13.76	14.00
144 (UNII-3 Band)	5720	3.52	3.52

802.11ac (VHT20)

Channel	Channel Frequency (MHz)	Occupied Bandwidth (MHz)	
		CHAIN 2	CHAIN 3
52	5260	18.12	18.24
60	5300	18.12	18.12
64	5320	18.12	18.12
100	5500	18.24	18.12
116	5580	18.24	18.24
140	5700	18.36	18.24
144 (UNII-2C Band)	5720	14.24	14.24
144 (UNII-3 Band)	5720	4.12	4.00

802.11ac (VHT40)

Channel	Channel Frequency (MHz)	Occupied Bandwidth (MHz)	
		CHAIN 2	CHAIN 3
54	5270	36.48	36.72
62	5310	36.48	36.96
102	5510	36.72	36.96
110	5550	36.72	36.72
134	5670	37.20	36.96
142 (UNII-2C Band)	5710	33.60	33.80
142 (UNII-3 Band)	5710	3.40	3.40

802.11ac (VHT80)

Channel	Channel Frequency (MHz)	Occupied Bandwidth (MHz)	
		CHAIN 2	CHAIN 3
58	5290	75.84	76.32
106	5530	76.32	76.32
122	5610	76.32	76.32
138 (UNII-2C Band)	5690	73.40	73.40
138 (UNII-3 Band)	5690	2.44	2.92

Spectrum Plot of Worst Value

802.11a_Chain 2 / CH140

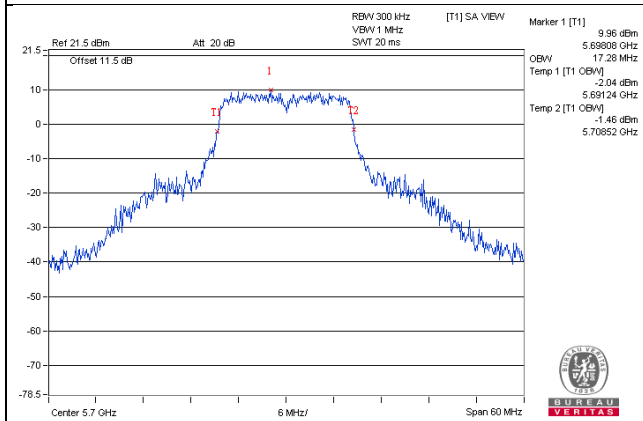

802.11ac (VHT20)_Chain 2 / CH140

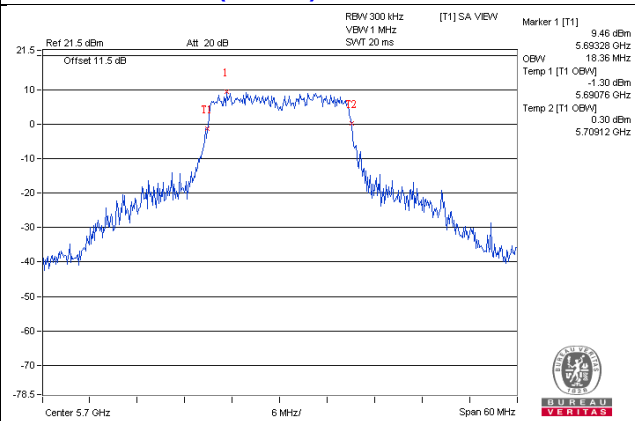

802.11ac (VHT40)_Chain 2 / CH134

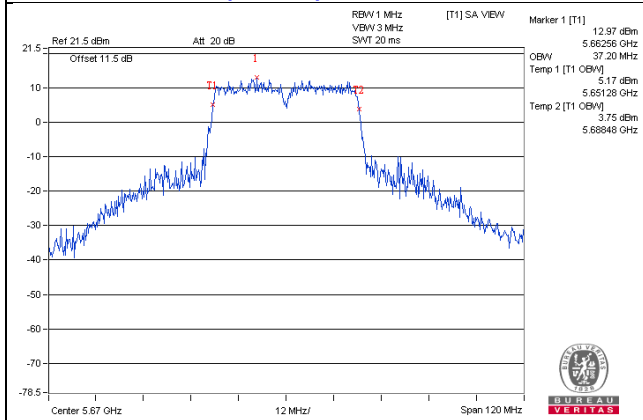

802.11ac (VHT80)_Chain 2 / CH106

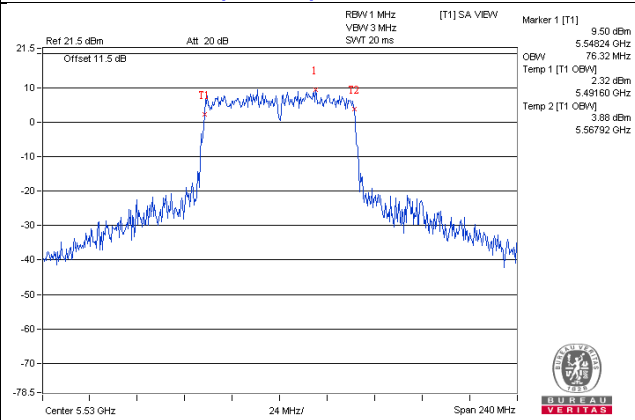

4.4.7 Test Results (Mode 4)

For U-NII-2A:

802.11a

Channel	Channel Frequency (MHz)	Occupied Bandwidth (MHz)
		Chain 3
52	5260	18.60
60	5300	18.96
64	5320	17.16

802.11ac (VHT20)

Channel	Channel Frequency (MHz)	Occupied Bandwidth (MHz)
		Chain 3
52	5260	19.56
60	5300	19.20
64	5320	18.12

802.11ac (VHT40)

Channel	Channel Frequency (MHz)	Occupied Bandwidth (MHz)
		Chain 3
54	5270	38.16
62	5310	36.72

802.11ac (VHT80)

Channel	Channel Frequency (MHz)	Occupied Bandwidth (MHz)
		Chain 3
58	5290	75.84

Spectrum Plot of Worst Value

802.11a / CH60

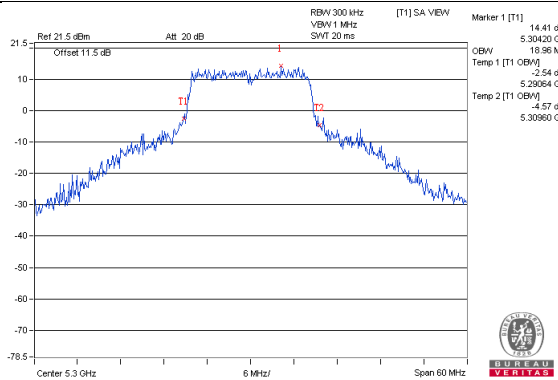

802.11ac(VHT20) / CH52

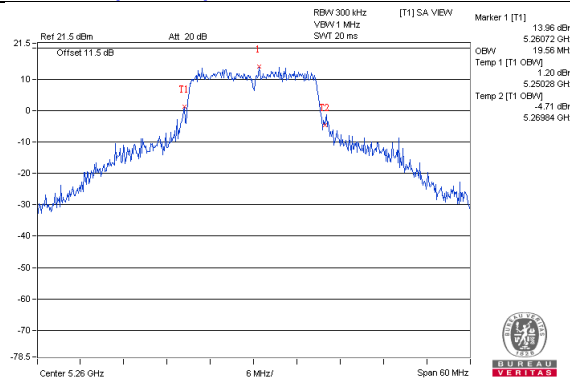

802.11ac(VHT40) / CH54

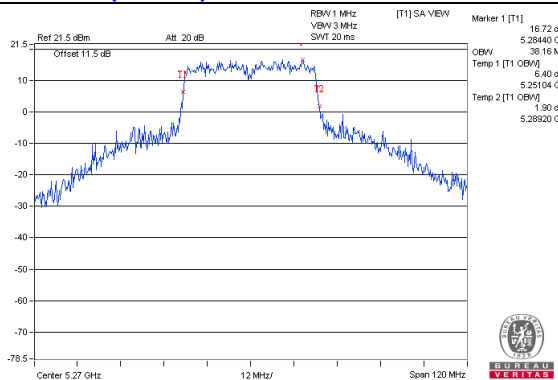

802.11ac (VHT80) / CH58

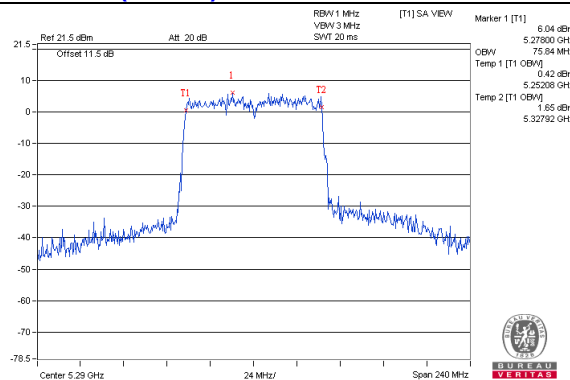

For U-NII-2C:
802.11a

Channel	Channel Frequency (MHz)	Occupied Bandwidth (MHz)
		Chain 2
100	5500	17.52
116	5580	18.24
140	5700	18.00
144 (UNII-2C Band)	5720	13.64
144 (UNII-3 Band)	5720	3.40

802.11ac (VHT20)

Channel	Channel Frequency (MHz)	Occupied Bandwidth (MHz)
		Chain 2
100	5500	18.48
116	5580	18.96
140	5700	18.24
144 (UNII-2C Band)	5720	14.12
144 (UNII-3 Band)	5720	4.00

802.11ac (VHT40)

Channel	Channel Frequency (MHz)	Occupied Bandwidth (MHz)
		Chain 2
102	5510	36.96
110	5550	37.92
134	5670	37.20
142 (UNII-2C Band)	5720	33.60
142 (UNII-3 Band)	5720	3.60

802.11ac (VHT80)

Channel	Channel Frequency (MHz)	Occupied Bandwidth (MHz)
		Chain 2
106	5530	76.32
122	5610	76.32
138 (UNII-2C Band)	5690	73.88
138 (UNII-3 Band)	5690	3.40

Spectrum Plot of Worst Value

802.11a / CH116

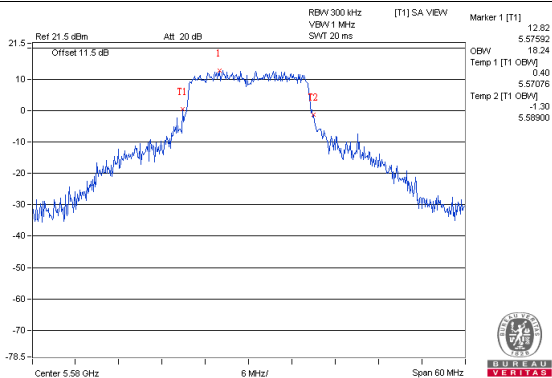

802.11ac(VHT20) / CH116

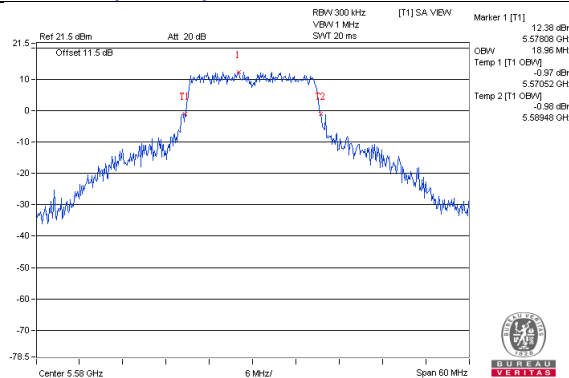

802.11ac(VHT40) / CH110

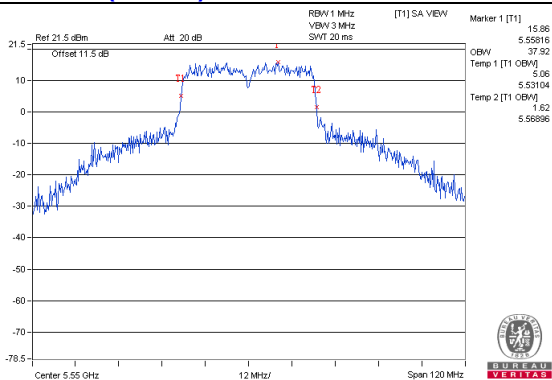

802.11ac (VHT80) / CH106

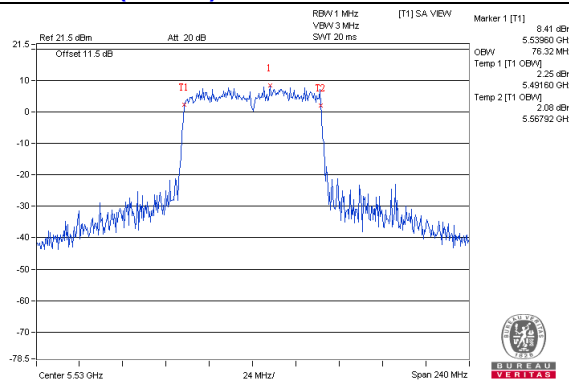

4.5 Peak Power Spectral Density Measurement

4.5.1 Limits of Peak Power Spectral Density Measurement

Operation Band	EUT Category		Limit
U-NII-1		Outdoor Access Point	17dBm/ MHz
		Fixed point-to-point Access Point	
		Indoor Access Point	
		Mobile and Portable client device	11dBm/ MHz
U-NII-2A		√	11dBm/ MHz
U-NII-2C		√	11dBm/ MHz
U-NII-3		√	30dBm/ 500kHz

4.5.2 Test Setup



4.5.3 Test Instruments

Refer to section 4.1.2 to get information of above instrument.

4.5.4 Test Procedure

For U_NII-2A, U_NII-2C band:

802.11a, 802.11ac (VHT20), 802.11ac (VHT40)

Using method SA-1

1. Set span to encompass the entire emission bandwidth (EBW) of the signal.
2. Set RBW = 1 MHz, Set VBW \geq 3 MHz, Detector = RMS
3. Sweep time = auto, trigger set to "free run".
4. Trace average at least 100 traces in power averaging mode.
5. Record the max value

802.11ac (VHT80)

Using method SA-2

1. Set span to encompass the entire emission bandwidth (EBW) of the signal.
2. Set RBW = 1 MHz, Set VBW \geq 3 MHz, Detector = RMS
3. Sweep time = auto, trigger set to "free run".
4. Trace average at least 100 traces in power averaging mode.
5. Record the max value and add 10 log (1/duty cycle)

For U_NII-3:

802.11a, 802.11ac (VHT20), 802.11ac (VHT40)

1. Set span to encompass the entire emission bandwidth (EBW) of the signal.
2. Set RBW = 300 kHz, Set VBW \geq 1 MHz, Detector = RMS
3. Use the peak marker function to determine the maximum power level in any 300 kHz band segment within the fundamental EBW.
4. Scale the observed power level to an equivalent value in 500 kHz by adjusting (reducing) the measured power by a bandwidth correction factor (BWCF) where $BWCF = 10\log(500\text{ kHz}/300\text{ kHz})$
5. Sweep time = auto, trigger set to "free run".
6. Trace average at least 100 traces in power averaging mode.
7. Record the max value and add 10 log (1/duty cycle)

802.11ac (VHT80)

1. Set span to encompass the entire emission bandwidth (EBW) of the signal.
2. Set RBW = 300 kHz, Set VBW \geq 1 MHz, Detector = RMS
3. Use the peak marker function to determine the maximum power level in any 300 kHz band segment within the fundamental EBW.
4. Scale the observed power level to an equivalent value in 500 kHz by adjusting (reducing) the measured power by a bandwidth correction factor (BWCF) where $BWCF = 10\log(500\text{ kHz}/300\text{ kHz})$
5. Sweep time = auto, trigger set to "free run".
6. Trace average at least 100 traces in power averaging mode.
7. Record the max value

4.5.5 Deviation from Test Standard

No deviation.

4.5.6 EUT Operating Condition

Same as Item 4.3.6.

4.5.7 Test Results (Mode 1)

For U_NII-2A, U_NII-2C

802.11a

Chan.	Chan. Freq. (MHz)	PSD (dBm/MHz)				Total Power Density (dBm/MHz)	MAX. Limit (dBm/MHz)	Pass / Fail
		Chain 0	Chain 1	Chain 2	Chain 3			
52	5260	0.07	-0.21	-0.33	-0.59	5.76	5.98	Pass
60	5300	-0.07	-0.19	-0.13	-0.67	5.76	5.98	Pass
64	5320	-0.31	0.00	-0.04	-0.28	5.87	5.98	Pass
100	5500	-0.30	-0.35	-0.20	-0.23	5.75	5.98	Pass
116	5580	-0.15	-0.32	-0.91	-0.21	5.63	5.98	Pass
140	5700	-0.17	-0.34	-0.63	-0.29	5.67	5.98	Pass
144 (UNII-2C Band)	5720	-1.08	-1.07	-1.36	-0.81	4.94	5.98	Pass

- Note:** 1. Method a) of power density measurement of KDB 662911 is using for calculating total power density. Total power density is summing entire spectra across corresponding frequency bins on the various outputs by computer.
2. Directional gain = $5\text{dBi} + 10\log(4) = 11.02\text{dBi} > 6\text{dBi}$, so the power density limit shall be reduced to $11 - (11.02 - 6) = 5.98\text{dBm}$.

802.11ac (VHT20)

Chan.	Chan. Freq. (MHz)	PSD (dBm/MHz)				Total Power Density (dBm/MHz)	MAX. Limit (dBm/MHz)	Pass / Fail
		Chain 0	Chain 1	Chain 2	Chain 3			
52	5260	-0.19	-0.34	-0.33	0.12	5.84	5.98	Pass
60	5300	-0.30	-0.30	-0.30	-0.15	5.76	5.98	Pass
64	5320	-0.42	-0.19	-0.26	0.12	5.84	5.98	Pass
100	5500	0.28	0.01	-0.45	-0.12	5.96	5.98	Pass
116	5580	0.37	-0.25	-0.62	-0.05	5.90	5.98	Pass
140	5700	0.02	-0.51	-0.74	0.15	5.77	5.98	Pass
144 (UNII-2C Band)	5720	-1.34	-0.83	-1.71	-0.70	4.89	5.98	Pass

- Note:** 1. Method a) of power density measurement of KDB 662911 is using for calculating total power density. Total power density is summing entire spectra across corresponding frequency bins on the various outputs by computer.
2. Directional gain = $5\text{dBi} + 10\log(4) = 11.02\text{dBi} > 6\text{dBi}$, so the power density limit shall be reduced to $11 - (11.02 - 6) = 5.98\text{dBm}$.

802.11ac (VHT40)

Chan.	Chan. Freq. (MHz)	PSD (dBm/MHz)				Total Power Density (dBm/MHz)	MAX. Limit (dBm/MHz)	Pass / Fail
		Chain 0	Chain 1	Chain 2	Chain 3			
54	5270	-3.47	-3.18	-3.53	-3.41	2.62	5.98	Pass
62	5310	-3.45	-3.16	-3.48	-3.18	2.71	5.98	Pass
102	5510	-3.22	-3.34	-3.84	-3.20	2.63	5.98	Pass
110	5550	-3.42	-3.22	-4.03	-3.11	2.59	5.98	Pass
134	5670	-3.35	-3.55	-3.61	-3.16	2.61	5.98	Pass
142 (UNII-2C Band)	5710	-4.46	-4.07	-4.47	-3.97	1.78	5.98	Pass

- Note:** 1. Method a) of power density measurement of KDB 662911 is using for calculating total power density. Total power density is summing entire spectra across corresponding frequency bins on the various outputs by computer.
2. Directional gain = $5\text{dBi} + 10\log(4) = 11.02\text{dBi} > 6\text{dBi}$, so the power density limit shall be reduced to $11 - (11.02 - 6) = 5.98\text{dBm}$.

802.11ac (VHT80)

Chan.	Chan. Freq. (MHz)	PSD W/O Duty Factor (dBm/MHz)				Duty Factor (dB)	Total PSD With Duty Factor (dBm/MHz)	MAX. Limit (dBm/MHz)	Pass / Fail
		Chain 0	Chain 1	Chain 2	Chain 3				
58	5290	-6.37	-6.61	-6.88	-6.47	0.28	-0.28	5.98	Pass
106	5530	-6.10	-6.33	-6.39	-5.76	0.28	0.16	5.98	Pass
122	5610	-5.74	-6.26	-6.52	-6.26	0.28	0.11	5.98	Pass
138 (UNII-2C Band)	5690	-7.70	-7.36	-7.21	-7.20	0.28	-1.07	5.98	Pass

- Note:** 1. Method a) of power density measurement of KDB 662911 is using for calculating total power density. Total power density is summing entire spectra across corresponding frequency bins on the various outputs by computer.
2. Directional gain = $5\text{dBi} + 10\log(4) = 11.02\text{dBi} > 6\text{dBi}$, so the power density limit shall be reduced to $11 - (11.02 - 6) = 5.98\text{dBm}$.
3. Refer to section 3.3 for duty cycle spectrum plot.

Spectrum Plot of Worst Value

802.11a / Chain 0 – CH52

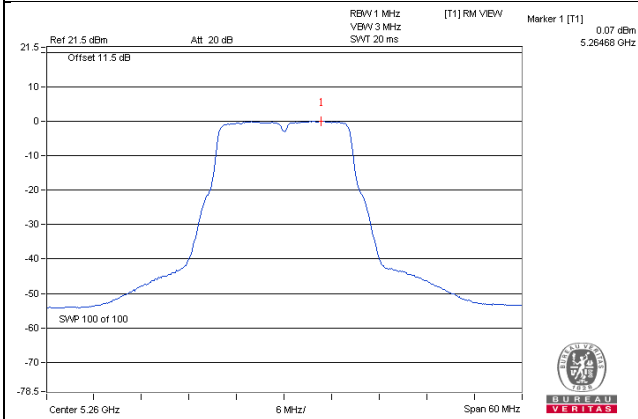

802.11ac (VHT20) / Chain 0 – CH16

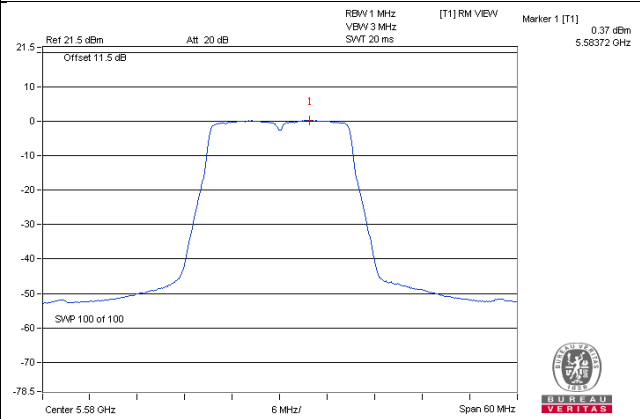

802.11ac (VHT40) / Chain 3 - CH110

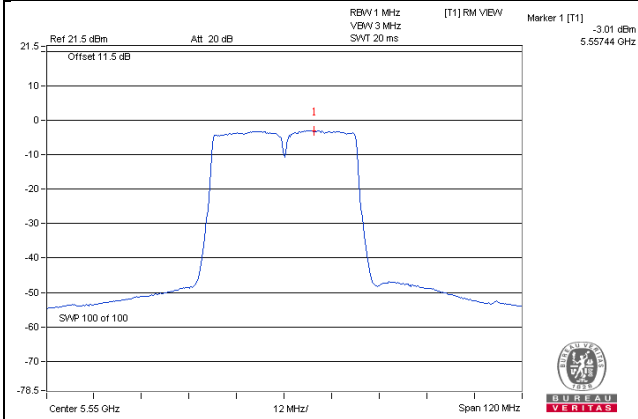

802.11ac (VHT80) / Chain 0- CH122

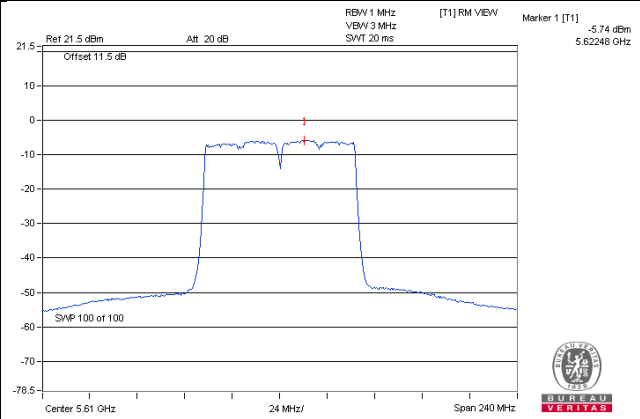

For U_NII-3

802.11a

TX chain	Chan.	Chan. Freq. (MHz)	PSD		10 log (N=4) dB	Total PSD (dBm/500kHz)	Limit (dBm/500kHz)	Pass /Fail
			(dBm/300kHz)	(dBm/500kHz)				
0	144 (UNII-3 Band)	5720	-9.18	-6.96	6.02	-0.94	24.98	Pass
1	144 (UNII-3 Band)	5720	-9.45	-7.23	6.02	-1.21	24.98	Pass
2	144 (UNII-3 Band)	5720	-9.74	-7.52	6.02	-1.50	24.98	Pass
3	144 (UNII-3 Band)	5720	-9.53	-7.31	6.02	-1.29	24.98	Pass

Note: 1. Directional gain = $5\text{dBi} + 10\log(4) = 11.02\text{dBi} > 6\text{dBi}$, so the power density limit shall be reduced to $30-(11.02-6) = 24.98\text{dBm}$.

802.11ac (VHT20)

TX chain	Chan.	Chan. Freq. (MHz)	PSD		10 log (N=4) dB	Total PSD (dBm/500kHz)	Limit (dBm/500kHz)	Pass /Fail
			(dBm/300kHz)	(dBm/500kHz)				
0	144 (UNII-3 Band)	5720	-9.69	-7.47	6.02	-1.45	24.98	Pass
1	144 (UNII-3 Band)	5720	-9.42	-7.20	6.02	-1.18	24.98	Pass
2	144 (UNII-3 Band)	5720	-10.36	-8.14	6.02	-2.12	24.98	Pass
3	144 (UNII-3 Band)	5720	-9.20	-6.98	6.02	-0.96	24.98	Pass

Note: 1. Directional gain = $5\text{dBi} + 10\log(4) = 11.02\text{dBi} > 6\text{dBi}$, so the power density limit shall be reduced to $30-(11.02-6) = 24.98\text{dBm}$.

802.11ac (VHT40)

TX chain	Chan.	Chan. Freq. (MHz)	PSD		10 log (N=4) dB	Total PSD (dBm/500kHz)	Limit (dBm/500kHz)	Pass /Fail
			(dBm/300kHz)	(dBm/500kHz)				
0	142 (UNII-3 Band)	5710	-13.50	-11.28	6.02	-5.26	24.98	Pass
1	142 (UNII-3 Band)	5710	-13.11	-10.89	6.02	-4.87	24.98	Pass
2	142 (UNII-3 Band)	5710	-13.53	-11.31	6.02	-5.29	24.98	Pass
3	142 (UNII-3 Band)	5710	-12.93	-10.71	6.02	-4.69	24.98	Pass

Note: 1. Directional gain = 5dBi + 10log(4) = 11.02dBi > 6dBi , so the power density limit shall be reduced to 30-(11.02-6) = 24.98dBm.

802.11ac (VHT80)

TX chain	Chan.	Chan. Freq. (MHz)	PSD W/O Duty Factor		10 log (N=4) dB	Duty Factor (dB)	Total PSD With Duty Factor (dBm/500kHz)	Limit (dBm/500kHz)	Pass /Fail
			(dBm/300kHz)	(dBm/500kHz)					
0	138 (UNII-3 Band)	5690	-17.43	-15.21	6.02	0.28	-8.91	24.98	Pass
1	138 (UNII-3 Band)	5690	-17.44	-15.22	6.02	0.28	-8.92	24.98	Pass
2	138 (UNII-3 Band)	5690	-17.13	-14.91	6.02	0.28	-8.61	24.98	Pass
2	138 (UNII-3 Band)	5690	-17.31	-15.09	6.02	0.28	-8.79	24.98	Pass

Note: 1. Directional gain = 5dBi + 10log(4) = 11.02dBi > 6dBi , so the power density limit shall be reduced to 30-(11.02-6) = 24.98dBm.

2. Refer to section 3.3 for duty cycle spectrum plot.

Spectrum Plot of Worst Value

802.11a / Chain 0 – CH144 (UNII-3 Band)

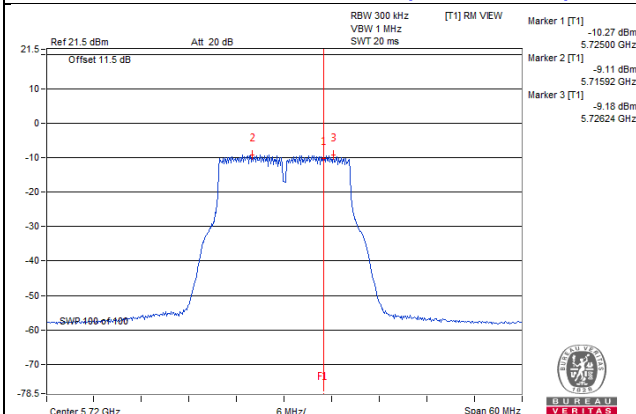

802.11a (VHT20) / Chain 3 – CH144 (UNII-3 Band)

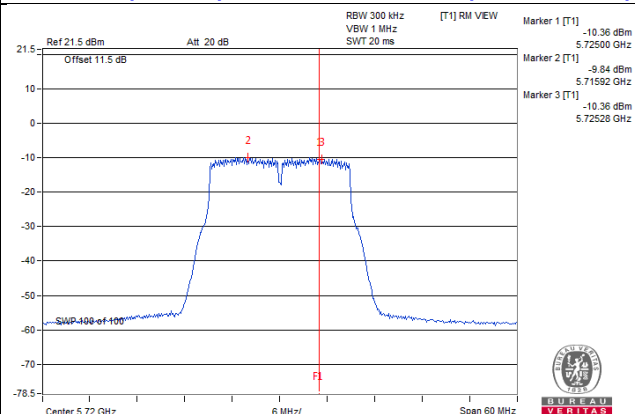

802.11ac (VHT40) / Chain 3 – CH142 (UNII-3 Band)

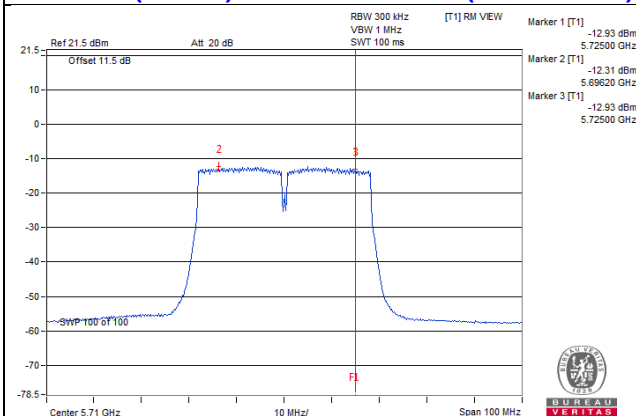

802.11ac (VHT80) / Chain 2 – CH138 (UNII-3 Band)

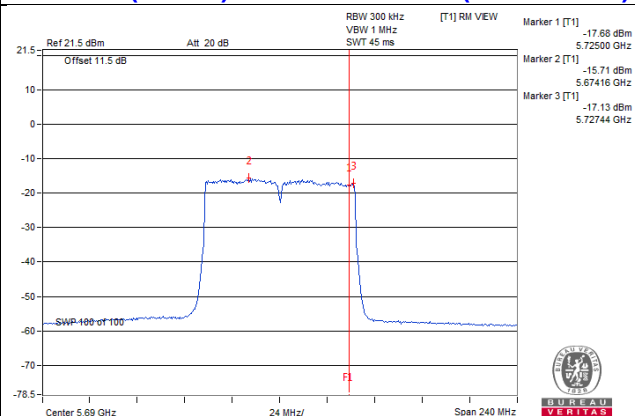

4.5.8 Test Results (Mode 2)

For U-NII-2A:

802.11a

Chan.	Chan. Freq. (MHz)	PSD (dBm/MHz)			Total Power Density (dBm/MHz)	MAX. Limit (dBm/MHz)	Pass / Fail
		Chain 0	Chain 2	Chain 3			
52	5260	2.11	2.20	2.75	7.13	7.23	Pass
60	5300	2.25	1.94	2.63	7.05	7.23	Pass
64	5320	2.11	2.01	2.74	7.07	7.23	Pass

- Note:** 1. Method a) of power density measurement of KDB 662911 is using for calculating total power density. Total power density is summing entire spectra across corresponding frequency bins on the various outputs by computer.
2. Directional gain = $5\text{dBi} + 10\log(3) = 9.77\text{dBi} > 6\text{dBi}$, so the power density limit shall be reduced to $11 - (9.77 - 6) = 7.23\text{dBm}$.

802.11ac (VHT20)

Chan.	Chan. Freq. (MHz)	PSD (dBm/MHz)			Total Power Density (dBm/MHz)	MAX. Limit (dBm/MHz)	Pass / Fail
		Chain 0	Chain 2	Chain 3			
52	5260	2.45	1.92	2.57	7.09	7.23	Pass
60	5300	2.48	1.89	2.47	7.06	7.23	Pass
64	5320	2.45	1.81	2.34	6.98	7.23	Pass

- Note:** 1. Method a) of power density measurement of KDB 662911 is using for calculating total power density. Total power density is summing entire spectra across corresponding frequency bins on the various outputs by computer.
2. Directional gain = $5\text{dBi} + 10\log(3) = 9.77\text{dBi} > 6\text{dBi}$, so the power density limit shall be reduced to $11 - (9.77 - 6) = 7.23\text{dBm}$.

802.11ac (VHT40)

Chan.	Chan. Freq. (MHz)	PSD (dBm/MHz)			Total Power Density (dBm/MHz)	MAX. Limit (dBm/MHz)	Pass / Fail
		Chain 0	Chain 2	Chain 3			
54	5270	-0.50	-1.00	-0.36	4.16	7.23	Pass
62	5310	-0.45	-1.11	-0.25	4.18	7.23	Pass

- Note:** 1. Method a) of power density measurement of KDB 662911 is using for calculating total power density. Total power density is summing entire spectra across corresponding frequency bins on the various outputs by computer.
2. Directional gain = $5\text{dBi} + 10\log(3) = 9.77\text{dBi} > 6\text{dBi}$, so the power density limit shall be reduced to $11 - (9.77 - 6) = 7.23\text{dBm}$.

802.11ac (VHT80)

Chan.	Chan. Freq. (MHz)	PSD W/O Duty Factor (dBm/MHz)			Duty Factor (dB)	Total PSD With Duty Factor (dBm/MHz)	MAX. Limit (dBm/MHz)	Pass / Fail
		Chain 0	Chain 2	Chain 3				
58	5290	-5.67	-6.30	-5.29	0.28	-0.69	7.23	Pass

- Note:**
- Method a) of power density measurement of KDB 662911 is using for calculating total power density. Total power density is summing entire spectra across corresponding frequency bins on the various outputs by computer.
 - Directional gain = $5\text{dBi} + 10\log(3) = 9.77\text{dBi} > 6\text{dBi}$, so the power density limit shall be reduced to $11 - (9.77 - 6) = 7.23\text{dBm}$.
 - Refer to section 3.3 for duty cycle spectrum plot.

Spectrum Plot of Worst Value

802.11a_Chain 3 / CH52

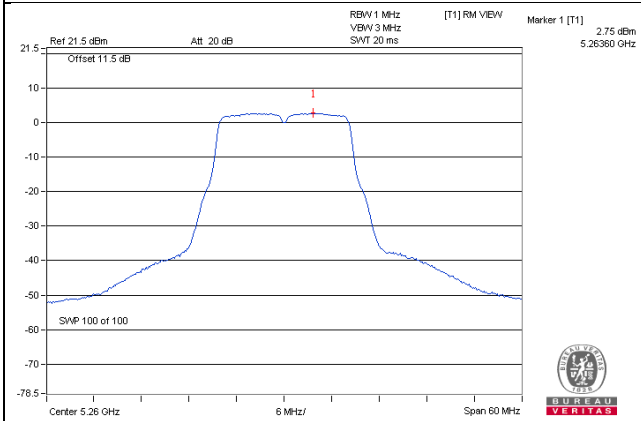

802.11ac (VHT20)_Chain 3 / CH52

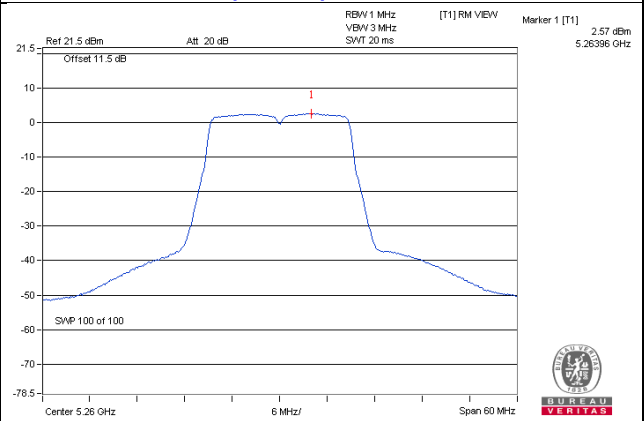

802.11ac (VHT40)_Chain 3 / CH62

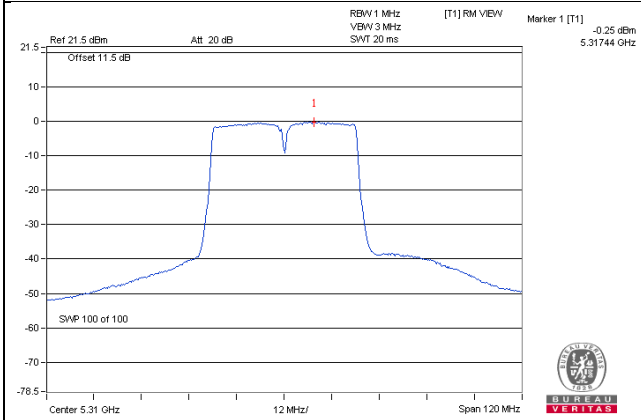

802.11ac (VHT80)_Chain 3 / CH58

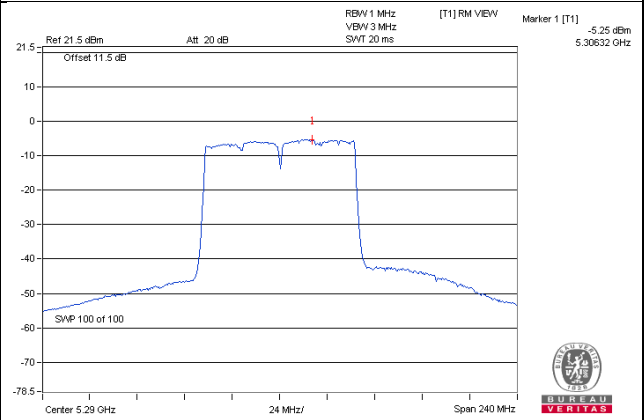

For U-NII-2C:
802.11a

Chan.	Chan. Freq. (MHz)	PSD (dBm/MHz)			Total Power Density (dBm/MHz)	MAX. Limit (dBm/MHz)	Pass / Fail
		Chain 1	Chain 2	Chain 3			
100	5500	2.59	2.45	1.84	7.08	7.23	Pass
116	5580	1.98	2.32	2.39	7.00	7.23	Pass
140	5700	2.13	2.27	2.72	7.15	7.23	Pass
144 (UNII-2C Band)	5720	1.71	1.63	2.06	6.58	7.23	Pass

- Note:** 1. Method a) of power density measurement of KDB 662911 is using for calculating total power density. Total power density is summing entire spectra across corresponding frequency bins on the various outputs by computer.
2. Directional gain = 5dBi + 10log(3) = 9.77dBi > 6dBi , so the power density limit shall be reduced to 11-(9.77-6) = 7.23dBm.

802.11ac (VHT20)

Chan.	Chan. Freq. (MHz)	PSD (dBm/MHz)			Total Power Density (dBm/MHz)	MAX. Limit (dBm/MHz)	Pass / Fail
		Chain 1	Chain 2	Chain 3			
100	5500	1.92	2.41	2.75	7.14	7.23	Pass
116	5580	2.15	2.12	2.71	7.11	7.23	Pass
140	5700	1.90	2.05	2.71	7.01	7.23	Pass
144 (UNII-2C Band)	5720	0.30	1.10	0.92	5.56	7.23	Pass

- Note:** 1. Method a) of power density measurement of KDB 662911 is using for calculating total power density. Total power density is summing entire spectra across corresponding frequency bins on the various outputs by computer.
2. Directional gain = 5dBi + 10log(3) = 9.77dBi > 6dBi , so the power density limit shall be reduced to 11-(9.77-6) = 7.23dBm.

802.11ac (VHT40)

Chan.	Chan. Freq. (MHz)	PSD (dBm/MHz)			Total Power Density (dBm/MHz)	MAX. Limit (dBm/MHz)	Pass / Fail
		Chain 1	Chain 2	Chain 3			
102	5510	-0.55	-0.60	-0.60	4.19	7.23	Pass
110	5550	-0.32	-0.57	-0.63	4.27	7.23	Pass
134	5670	-0.65	-0.80	-0.69	4.06	7.23	Pass
142 (UNII-2C Band)	5710	-1.53	-1.73	-1.29	3.26	7.23	Pass

- Note:**
- Method a) of power density measurement of KDB 662911 is using for calculating total power density. Total power density is summing entire spectra across corresponding frequency bins on the various outputs by computer.
 - Directional gain = $5\text{dBi} + 10\log(3) = 9.77\text{dBi} > 6\text{dBi}$, so the power density limit shall be reduced to $11 - (9.77 - 6) = 7.23\text{dBm}$.

802.11ac (VHT80)

Chan.	Chan. Freq. (MHz)	PSD W/O Duty Factor (dBm/MHz)			Duty Factor (dB)	Total PSD With Duty Factor (dBm/MHz)	MAX. Limit (dBm/MHz)	Pass / Fail
		Chain 1	Chain 2	Chain 3				
106	5530	-3.41	-3.97	-3.67	0.28	1.37	7.23	Pass
122	5610	-3.77	-4.25	-3.97	0.28	1.05	7.23	Pass
138 (UNII-2C Band)	5690	-4.91	-4.87	-4.59	0.28	0.26	7.23	Pass

- Note:**
- Method a) of power density measurement of KDB 662911 is using for calculating total power density. Total power density is summing entire spectra across corresponding frequency bins on the various outputs by computer.
 - Directional gain = $5\text{dBi} + 10\log(3) = 9.77\text{dBi} > 6\text{dBi}$, so the power density limit shall be reduced to $11 - (9.77 - 6) = 7.23\text{dBm}$.
 - Refer to section 3.3 for duty cycle spectrum plot.

Spectrum Plot of Worst Value

802.11a_Chain 1 / CH100

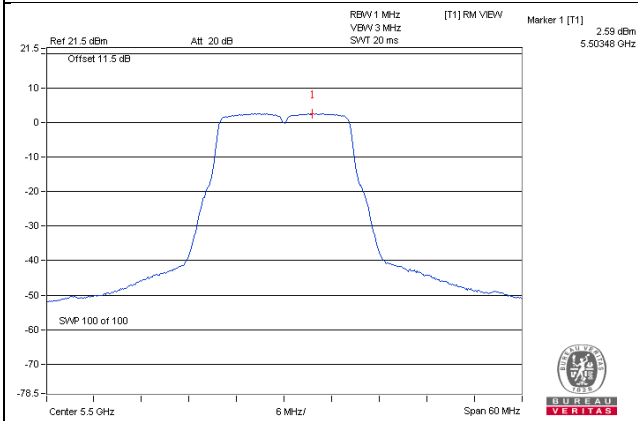

802.11ac (VHT20)_Chain 3 / CH100

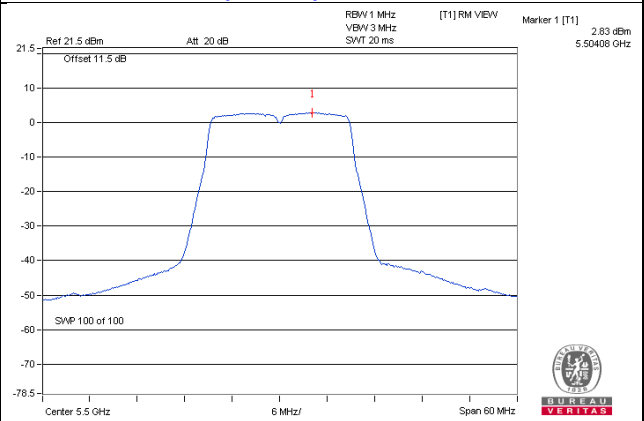

802.11ac (VHT40)_Chain 1 / CH110

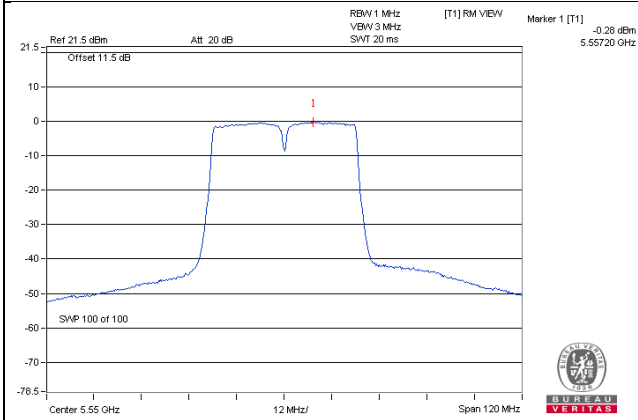

802.11ac (VHT80)_Chain 1 / CH106

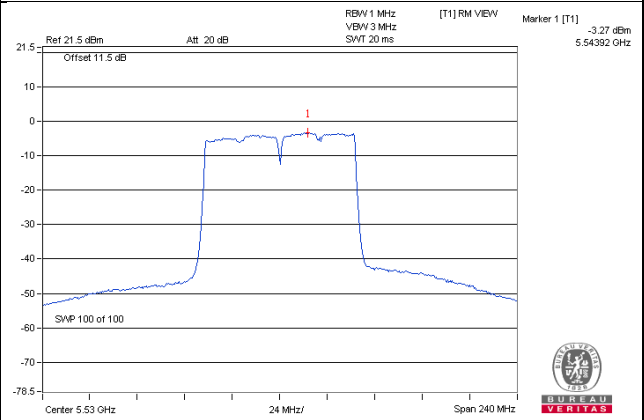

For U-NII-3

802.11a

TX chain	Chan.	Chan. Freq. (MHz)	PSD		10 log (N=3) dB	Total PSD (dBm/500kHz)	Limit (dBm/500kHz)	Pass /Fail
			(dBm/300kHz)	(dBm/500kHz)				
0	144 (UNII-3 Band)	5720	-6.59	-4.37	4.77	0.40	26.23	Pass
1	144 (UNII-3 Band)	5720	-6.92	-4.70	4.77	0.07	26.23	Pass
2	144 (UNII-3 Band)	5720	-6.62	-4.40	4.77	0.37	26.23	Pass

Note: 1. Directional gain = 5dBi + 10log(3) = 9.77dBi > 6dBi , so the power density limit shall be reduced to 30-(9.77-6) =26.23dBm.

802.11ac (VHT20)

TX chain	Chan.	Chan. Freq. (MHz)	PSD		10 log (N=3) dB	Total PSD (dBm/500kHz)	Limit (dBm/500kHz)	Pass /Fail
			(dBm/300kHz)	(dBm/500kHz)				
0	144 (UNII-3 Band)	5720	-8.23	-6.01	4.77	-1.24	26.23	Pass
1	144 (UNII-3 Band)	5720	-7.17	-4.95	4.77	-0.18	26.23	Pass
2	144 (UNII-3 Band)	5720	-7.62	-5.40	4.77	-0.63	26.23	Pass

Note: 1. Directional gain = 5dBi + 10log(3) = 9.77dBi > 6dBi , so the power density limit shall be reduced to 30-(9.77-6) =26.23dBm.

802.11ac (VHT40)

TX chain	Chan.	Chan. Freq. (MHz)	PSD		10 log (N=3) dB	Total PSD (dBm/500kHz)	Limit (dBm/500kHz)	Pass /Fail
			(dBm/300kHz)	(dBm/500kHz)				
0	142 (UNII-3 Band)	5710	-10.68	-8.46	4.77	-3.69	26.23	Pass
1	142 (UNII-3 Band)	5710	-10.70	-8.48	4.77	-3.71	26.23	Pass
2	142 (UNII-3 Band)	5710	-10.02	-7.80	4.77	-3.03	26.23	Pass

Note: 1. Directional gain = 5dBi + 10log(3) = 9.77dBi > 6dBi , so the power density limit shall be reduced to 30-(9.77-6) =26.23dBm.

802.11ac (VHT80)

TX chain	Chan.	Chan. Freq. (MHz)	PSD W/O Duty Factor		10 log (N=3) dB	Duty Factor (dB)	Total PSD With Duty Factor (dBm/500kHz)	Limit (dBm/500kHz)	Pass /Fail
			(dBm/300kHz)	(dBm/500kHz)					
0	138 (UNII-3 Band)	5690	-14.77	-12.55	4.77	0.28	-7.50	26.23	Pass
1	138 (UNII-3 Band)	5690	-14.70	-12.48	4.77	0.28	-7.43	26.23	Pass
2	138 (UNII-3 Band)	5690	-14.59	-12.37	4.77	0.28	-7.32	26.23	Pass

Note: 1. Directional gain = $5\text{dBi} + 10\log(3) = 9.77\text{dBi} > 6\text{dBi}$, so the power density limit shall be reduced to $30 - (9.77 - 6) = 26.23\text{dBm}$.

2. Refer to section 3.3 for duty cycle spectrum plot.

Spectrum Plot of Worst Value

802.11a / Chain 1 – CH144 (UNII-3 Band)

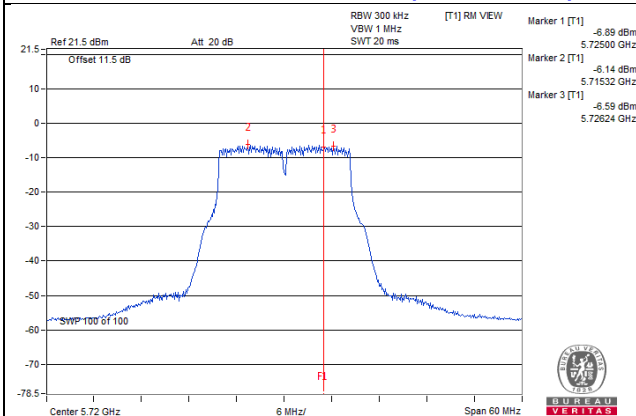

802.11ac (VHT20) / Chain 2 – CH144 (UNII-3 Band)

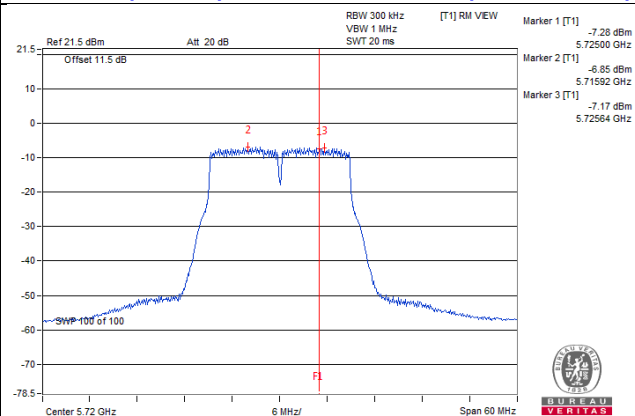

802.11ac (VHT40) / Chain 3 – CH142 (UNII-3 Band)

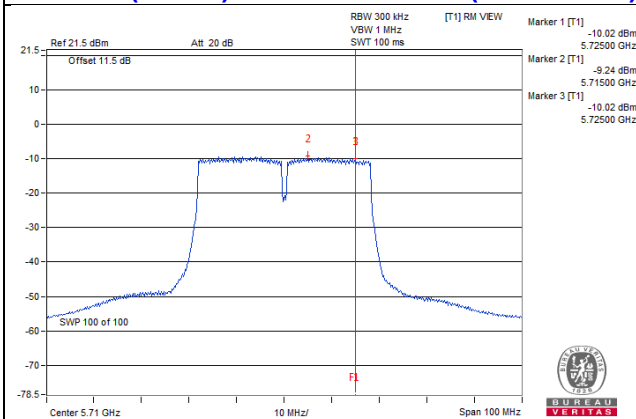

802.11ac (VHT80) / Chain 3 – CH138 (UNII-3 Band)

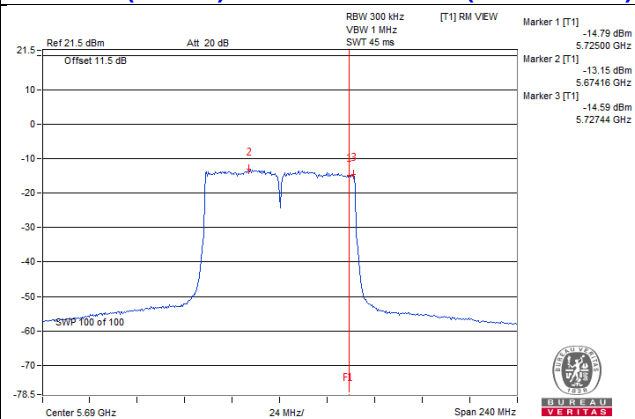

4.5.9 Test Results (Mode 3)

For UNII-2A, UNII-2C:

802.11a

Chan.	Chan. Freq. (MHz)	PSD (dBm/MHz)		Total Power Density (dBm/MHz)	MAX. Limit (dBm/MHz)	Pass / Fail
		Chain 2	Chain 3			
52	5260	5.44	6.11	8.80	8.99	Pass
60	5300	5.55	6.25	8.92	8.99	Pass
64	5320	5.36	6.27	8.85	8.99	Pass
100	5500	5.79	5.94	8.88	8.99	Pass
116	5580	5.84	5.99	8.93	8.99	Pass
140	5700	5.61	5.87	8.75	8.99	Pass
144 (UNII-2C Band)	5720	4.47	5.58	8.07	8.99	Pass

- Note:** 1. Method a) of power density measurement of KDB 662911 is using for calculating total power density. Total power density is summing entire spectra across corresponding frequency bins on the various outputs by computer.
2. Directional gain = $5\text{dBi} + 10\log(2) = 8.01\text{dBi} > 6\text{dBi}$, so the power density limit shall be reduced to $11 - (8.01 - 6) = 8.99\text{dBm}$.

802.11ac (VHT20)

Chan.	Chan. Freq. (MHz)	PSD (dBm/MHz)		Total Power Density (dBm/MHz)	MAX. Limit (dBm/MHz)	Pass / Fail
		Chain 2	Chain 3			
52	5260	5.41	6.06	8.76	8.99	Pass
60	5300	5.44	6.04	8.76	8.99	Pass
64	5320	5.25	6.11	8.71	8.99	Pass
100	5500	5.61	5.93	8.78	8.99	Pass
116	5580	5.62	5.96	8.80	8.99	Pass
140	5700	5.26	5.95	8.63	8.99	Pass
144 (UNII-2C Band)	5720	5.01	4.67	7.85	8.99	Pass

- Note:** 1. Method a) of power density measurement of KDB 662911 is using for calculating total power density. Total power density is summing entire spectra across corresponding frequency bins on the various outputs by computer.
2. Directional gain = $5\text{dBi} + 10\log(2) = 8.01\text{dBi} > 6\text{dBi}$, so the power density limit shall be reduced to $11 - (8.01 - 6) = 8.99\text{dBm}$.

802.11ac (VHT40)

Chan.	Chan. Freq. (MHz)	PSD (dBm/MHz)		Total Power Density (dBm/MHz)	MAX. Limit (dBm/MHz)	Pass / Fail
		Chain 2	Chain 3			
54	5270	2.64	3.23	5.96	8.99	Pass
62	5310	2.03	2.66	5.37	8.99	Pass
102	5510	2.77	3.27	6.04	8.99	Pass
110	5550	2.69	3.37	6.05	8.99	Pass
134	5670	2.51	3.10	5.83	8.99	Pass
142 (UNII-2C Band)	5710	1.68	2.05	4.88	8.99	Pass

- Note:** 1. Method a) of power density measurement of KDB 662911 is using for calculating total power density. Total power density is summing entire spectra across corresponding frequency bins on the various outputs by computer.
2. Directional gain = $5\text{dBi} + 10\log(2) = 8.01\text{dBi} > 6\text{dBi}$, so the power limit shall be reduced to $11 - (8.01 - 6) = 8.99\text{dBm}$.

802.11ac (VHT80)

Chan.	Chan. Freq. (MHz)	PSD W/O Duty Factor (dBm/MHz)		Duty Factor (dB)	Total PSD With Duty Factor (dBm/MHz)	MAX. Limit (dBm/MHz)	Pass / Fail
		Chain 2	Chain 3				
58	5290	-0.93	-0.75	0.28	2.45	8.99	Pass
106	5530	-0.48	0.27	0.28	3.20	8.99	Pass
122	5610	-1.60	0.57	0.28	2.90	8.99	Pass
138 (UNII-2C Band)	5690	-2.29	-0.91	0.28	1.74	8.99	Pass

- Note:** 1. Method a) of power density measurement of KDB 662911 is using for calculating total power density. Total power density is summing entire spectra across corresponding frequency bins on the various outputs by computer.
2. Directional gain = $5\text{dBi} + 10\log(2) = 8.01\text{dBi} > 6\text{dBi}$, so the power density limit shall be reduced to $11 - (8.01 - 6) = 8.99\text{dBm}$.
3. Refer to section 3.3 for duty cycle spectrum plot.

Spectrum Plot of Worst Value

802.11a_Chain 3 / CH64

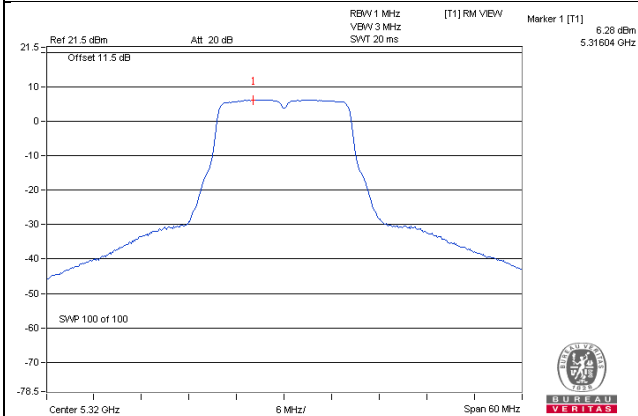

802.11ac (VHT20)_Chain 3 / CH64

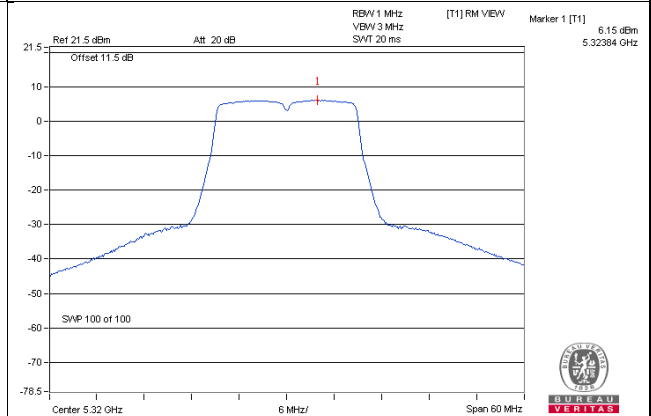

802.11ac (VHT40)_Chain 3 / CH110

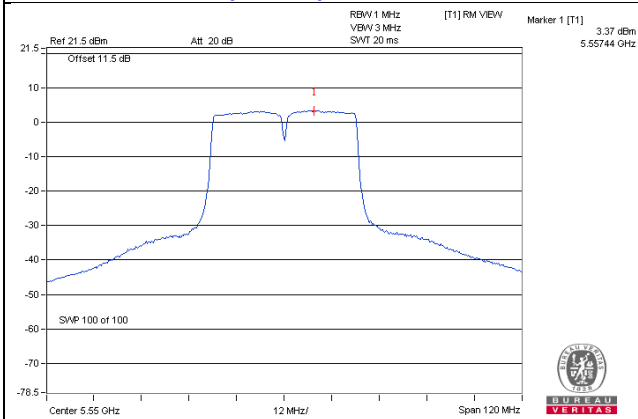

802.11ac (VHT80)_Chain 3 / CH122

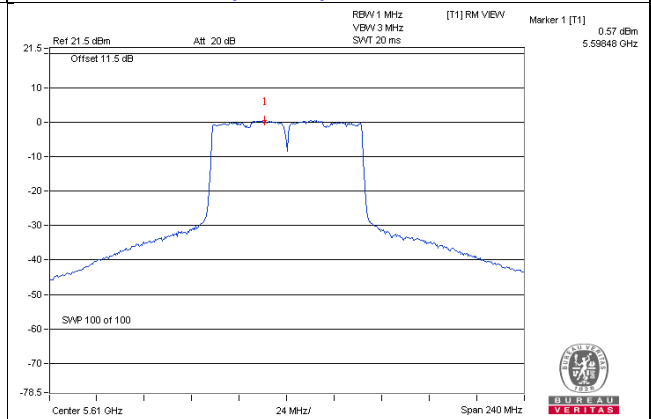

For UNII-3:

802.11a

TX chain	Chan.	Chan. Freq. (MHz)	PSD		10 log (N=2) dB	Total PSD (dBm/500kHz)	Limit (dBm/500kHz)	Pass /Fail
			(dBm/300kHz)	(dBm/500kHz)				
2	144 (UNII-3 Band)	5720	-4.54	-2.32	3.01	0.69	27.99	Pass
3	144 (UNII-3 Band)	5720	-2.75	-0.53	3.01	2.48	27.99	Pass

Note: 1. Directional gain = 5dBi + 10log(2) = 8.01dBi > 6dBi , so the power density limit shall be reduced to 30-(8.01-6) = 27.99dBm.

802.11ac (VHT20)

TX chain	Chan.	Chan. Freq. (MHz)	PSD		10 log (N=2) dB	Total PSD (dBm/500kHz)	Limit (dBm/500kHz)	Pass /Fail
			(dBm/300kHz)	(dBm/500kHz)				
2	144 (UNII-3 Band)	5720	-4.38	-2.16	3.01	0.85	27.99	Pass
3	144 (UNII-3 Band)	5720	-3.62	-1.40	3.01	1.61	27.99	Pass

Note: 1. Directional gain = 5dBi + 10log(2) = 8.01dBi > 6dBi , so the power density limit shall be reduced to 30-(8.01-6) = 27.99dBm.

802.11ac (VHT40)

TX chain	Chan.	Chan. Freq. (MHz)	PSD		10 log (N=2) dB	Total PSD (dBm/500kHz)	Limit (dBm/500kHz)	Pass /Fail
			(dBm/300kHz)	(dBm/500kHz)				
2	142 (UNII-3 Band)	5710	-7.14	-4.92	3.01	-1.91	27.99	Pass
3	142 (UNII-3 Band)	5710	-7.06	-4.84	3.01	-1.83	27.99	Pass

Note: 1. Directional gain = 5dBi + 10log(2) = 8.01dBi > 6dBi , so the power density limit shall be reduced to 30-(8.01-6) = 27.99dBm.

802.11ac (VHT80)

TX chain	Chan.	Chan. Freq. (MHz)	PSD W/O Duty Factor		10 log (N=2) dB	Duty Factor (dB)	Total PSD With Duty Factor (dBm/500kHz)	Limit (dBm/500kHz)	Pass /Fail
			(dBm/300kHz)	(dBm/500kHz)					
2	138 (UNII-3 Band)	5690	-11.70	-9.48	3.01	0.28	-6.19	27.99	Pass
3	138 (UNII-3 Band)	5690	-11.10	-8.88	3.01	0.28	-5.59	27.99	Pass

Note: 1. Directional gain = $5\text{dBi} + 10\log(2) = 8.01\text{dBi} > 6\text{dBi}$, so the power density limit shall be reduced to $30 - (8.01 - 6) = 27.99\text{dBm}$.

2. Refer to section 3.3 for duty cycle spectrum plot.

Spectrum Plot of Worst Value

802.11a / Chain 3 – CH144 (UNII-3 Band)

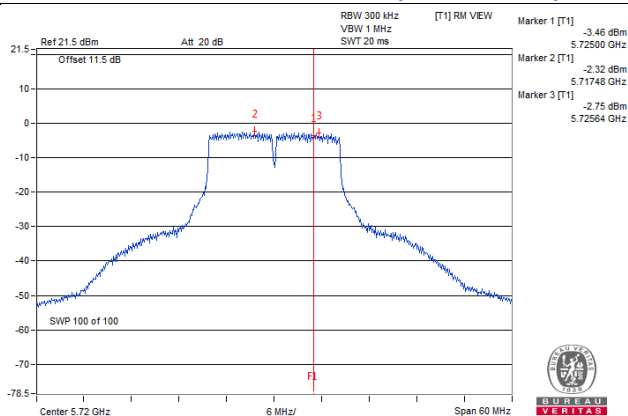

802.11ac (VHT20) / Chain 3 – CH144 (UNII-3 Band)

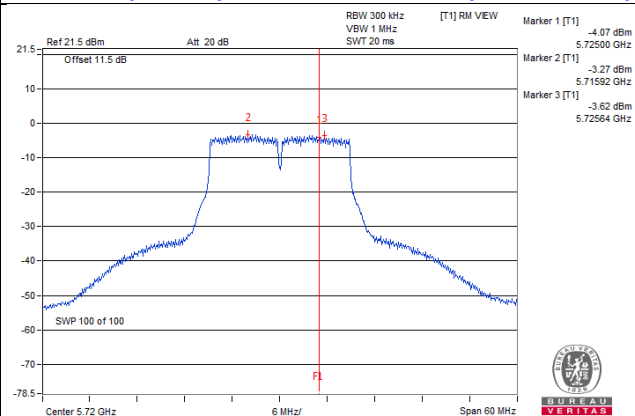

802.11ac (VHT40) / Chain 3 – CH142 (UNII-3 Band)

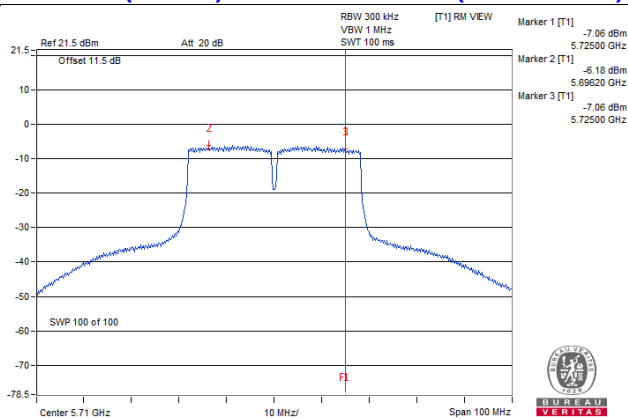

802.11ac (VHT80) / Chain 3 – CH138 (UNII-3 Band)

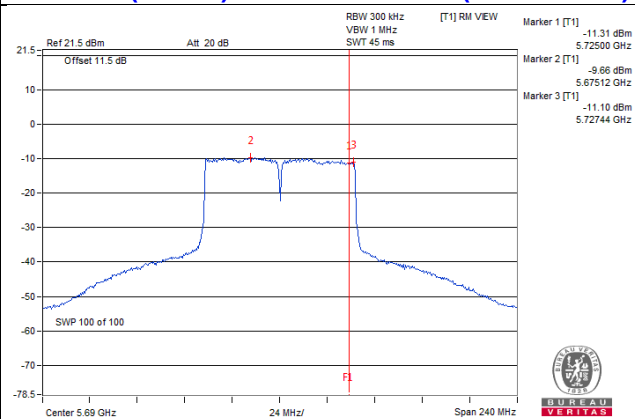

4.5.10 Test Results (Mode 4)

For UNII-2A

802.11a

Chan.	Chan. Freq. (MHz)	PSD (dBm/MHz)	MAX. Limit (dBm/MHz)	Pass / Fail
		Chain 3		
52	5260	9.74	11.00	Pass
60	5300	10.00	11.00	Pass
64	5320	7.86	11.00	Pass

802.11ac (VHT20)

Chan.	Chan. Freq. (MHz)	PSD (dBm/MHz)	MAX. Limit (dBm/MHz)	Pass / Fail
		Chain 3		
52	5260	9.75	11.00	Pass
60	5300	9.93	11.00	Pass
64	5320	7.30	11.00	Pass

802.11ac (VHT40)

Chan.	Chan. Freq. (MHz)	PSD (dBm/MHz)	MAX. Limit (dBm/MHz)	Pass / Fail
		Chain 3		
54	5270	6.89	11.00	Pass
62	5310	0.68	11.00	Pass

802.11ac (VHT80)

Chan.	Chan. Freq. (MHz)	PSD W/O Duty Factor (dBm/MHz)	Duty Factor (dB)	PSD With Duty Factor (dBm/MHz)	MAX. Limit (dBm/MHz)	Pass / Fail
		Chain 3				
58	5290	-3.50	0.28	-3.22	11.00	Pass

Note: 1. Refer to section 3.3 for duty cycle spectrum plot.

Spectrum Plot of Worst Value

802.11a / CH100

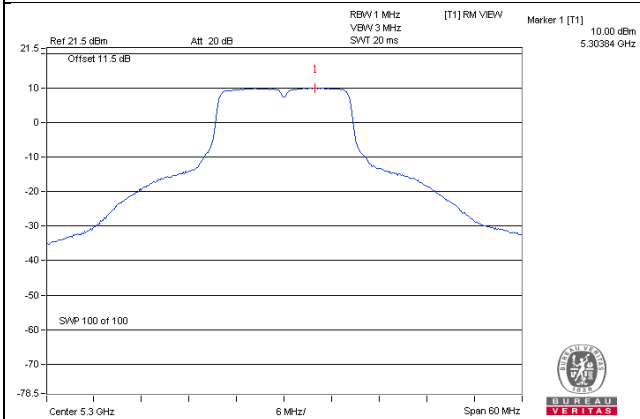

802.11ac (VHT20) / CH60

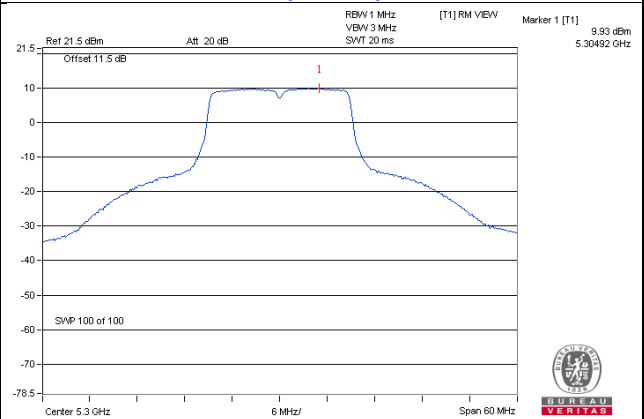

802.11ac (VHT40) / CH54

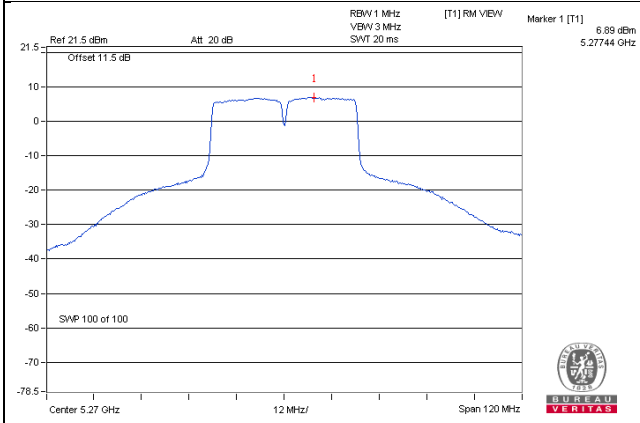

802.11ac (VHT80) / CH58

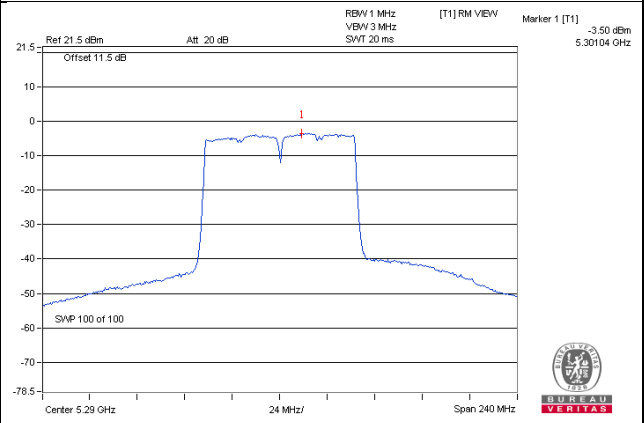

For UNII-2A
802.11a

Chan.	Chan. Freq. (MHz)	PSD (dBm/MHz)	MAX. Limit (dBm/MHz)	Pass / Fail
		Chain 2		
100	5500	8.15	11.00	Pass
116	5580	9.00	11.00	Pass
140	5700	6.81	11.00	Pass
144 (UNII-2C Band)	5720	4.68	11.00	Pass

802.11ac (VHT20)

Chan.	Chan. Freq. (MHz)	PSD (dBm/MHz)	MAX. Limit (dBm/MHz)	Pass / Fail
		Chain 2		
100	5500	7.70	11.00	Pass
116	5580	8.68	11.00	Pass
140	5700	5.36	11.00	Pass
144 (UNII-2C Band)	5720	4.08	11.00	Pass

802.11ac (VHT40)

Chan.	Chan. Freq. (MHz)	PSD (dBm/MHz)	MAX. Limit (dBm/MHz)	Pass / Fail
		Chain 2		
102	5510	1.58	11.00	Pass
110	5550	5.93	11.00	Pass
134	5670	3.21	11.00	Pass
142 (UNII-2C Band)	5710	2.38	11.00	Pass

802.11ac (VHT80)

Chan.	Chan. Freq. (MHz)	PSD W/O Duty Factor (dBm/MHz)	Duty Factor (dB)	PSD With Duty Factor (dBm/MHz)	MAX. Limit (dBm/MHz)	Pass / Fail
		Chain 2				
106	5530	-1.44	0.28	-1.16	11.00	Pass
122	5610	1.72	0.28	2.00	11.00	Pass
138 (UNII-2C Band)	5690	-2.38	0.28	-2.10	11.00	Pass

Note: 1. Refer to section 3.3 for duty cycle spectrum plot.

Spectrum Plot of Worst Value

802.11a / CH116

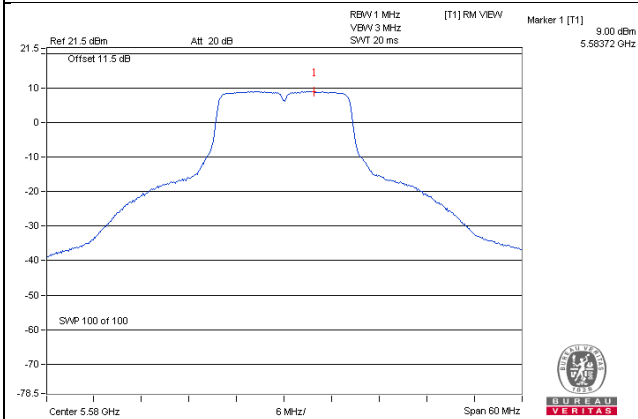

802.11ac (VHT20) / CH116

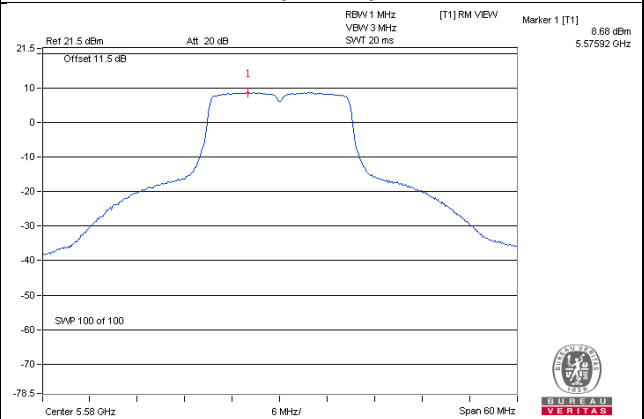

802.11ac (VHT40) / CH110

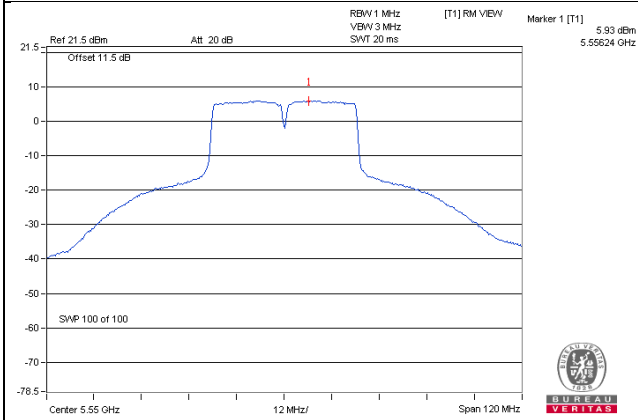

802.11ac (VHT80) / CH122

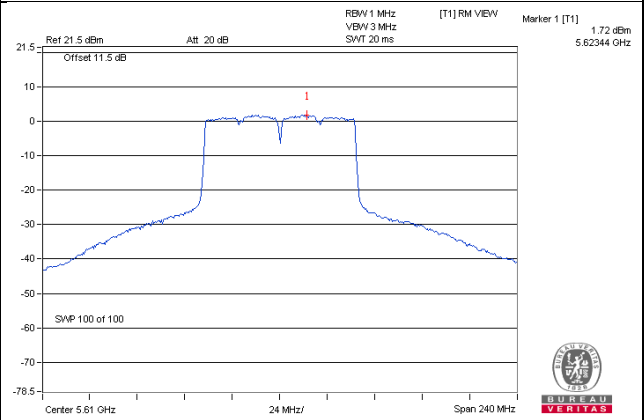

For UNII-3
802.11a

Chan.	Chan. Freq. (MHz)	PSD (dBm/300kHz)	PSD (dBm/500kHz)	Limit (dBm/500kHz)	Pass /Fail
144 (U-NII-3 Band)	5720	-4.37	-2.15	30.00	Pass

802.11ac (VHT20)

Chan.	Chan. Freq. (MHz)	PSD (dBm/300kHz)	PSD (dBm/500kHz)	Limit (dBm/500kHz)	Pass /Fail
144 (U-NII-3 Band)	5720	-4.82	-2.60	30.00	Pass

802.11ac (VHT40)

Chan.	Chan. Freq. (MHz)	PSD (dBm/300kHz)	PSD (dBm/500kHz)	Limit (dBm/500kHz)	Pass /Fail
142 (UNII-2C Band)	5710	-6.34	-4.12	30.00	Pass

802.11ac (VHT80)

Chan.	Chan. Freq. (MHz)	PSD W/O Duty Factor		Duty Factor (dB)	Total PSD With Duty Factor (dBm/500kHz)	Limit (dBm/500kHz)	Pass /Fail
		(dBm/300kHz)	(dBm/500kHz)				
138 (U-NII-3 Band)	5690	-9.28	-7.06	0.28	-6.78	30.00	Pass

Note: 1. Refer to section 3.3 for duty cycle spectrum plot.

Spectrum Plot of Worst Value

802.11a: CH 144 (UNII-3)

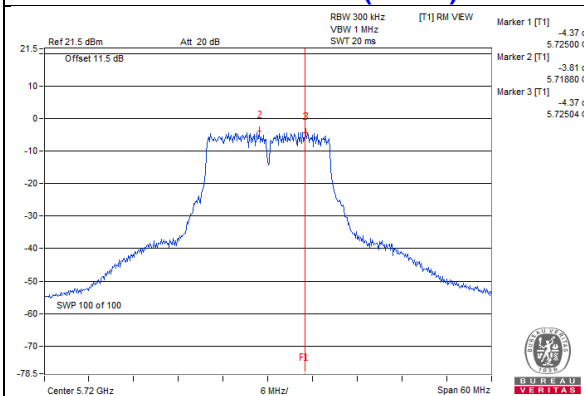

802.11ac (VHT20): CH 144 (UNII-3)

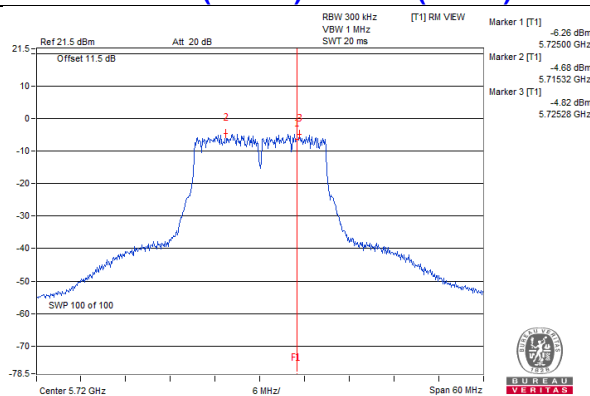

802.11ac (VHT40): CH 142 (UNII-3)

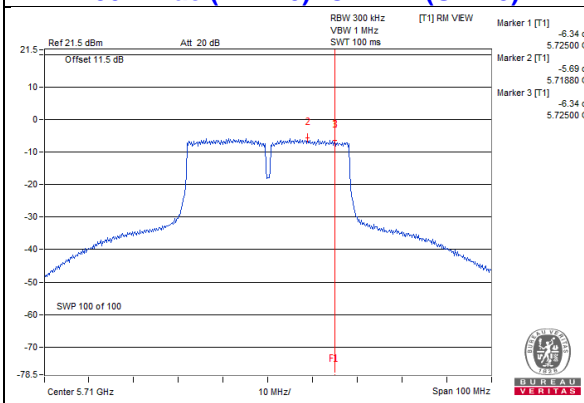

802.11ac (VHT80): CH 138 (UNII-3)

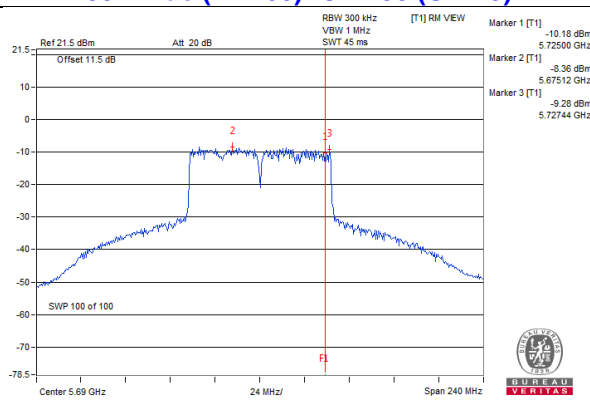

4.6 Frequency Stability Measurement

4.6.1 Limits of Frequency Stability Measurement

The frequency of the carrier signal shall be maintained within band of operation

4.6.2 Test Setup

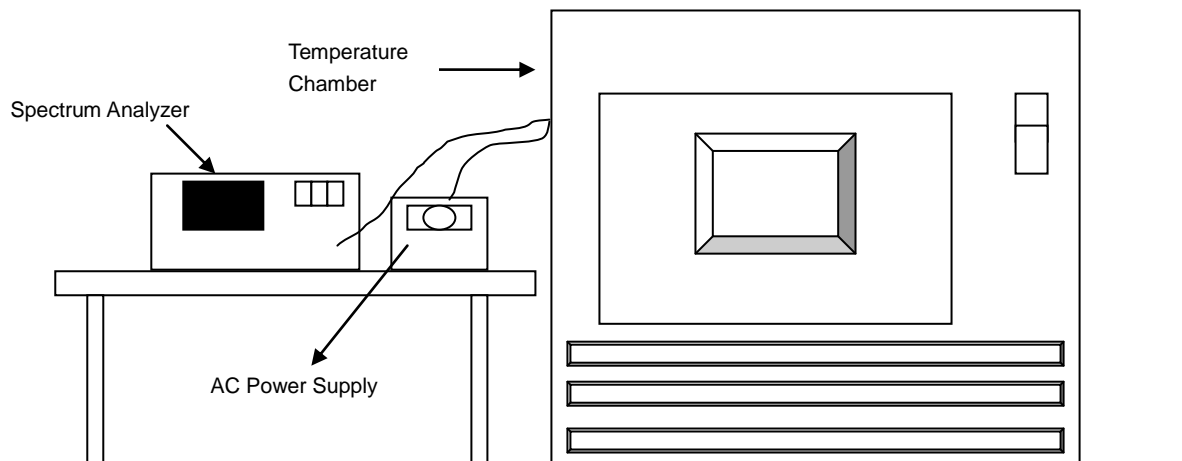

4.6.3 Test Instruments

Refer to section 4.1.2 to get information of above instrument.

4.6.4 Test Procedure

- The EUT was placed inside the environmental test chamber and powered by nominal AC voltage.
- Turn the EUT on and couple its output to a spectrum analyzer.
- Turn the EUT off and set the chamber to the highest temperature specified.
- Allow sufficient time (approximately 30 min) for the temperature of the chamber to stabilize, turn the EUT on and measure the operating frequency after 2, 5, and 10 Minutes.
- Repeat step 2 and 3 with the temperature chamber set to the lowest temperature.
- The test chamber was allowed to stabilize at +20 degree C for a minimum of 30 Minutes. The supply voltage was then adjusted on the EUT from 85% to 115% and the frequency record.

4.6.5 Deviation from Test Standard

No deviation.

4.6.6 EUT Operating Condition

Set the EUT transmit at un-modulation mode to test frequency stability.

4.6.7 Test Results (Mode 1)

Frequency Stability Versus Temp.									
Operating Frequency: 5500 MHz									
TEMP. (°C)	Power Supply (Vac)	0 Minute		2 Minute		5 Minute		10 Minute	
		Measured Frequency (MHz)	Pass/Fail	Measured Frequency (MHz)	Pass/Fail	Measured Frequency (MHz)	Pass/Fail	Measured Frequency (MHz)	Pass/Fail
50	120	5500.0228	PASS	5500.0243	PASS	5500.0208	PASS	5500.0213	PASS
40	120	5499.9881	PASS	5499.9911	PASS	5499.9895	PASS	5499.9883	PASS
30	120	5500.0085	PASS	5500.007	PASS	5500.0064	PASS	5500.0078	PASS
20	120	5499.9917	PASS	5499.993	PASS	5499.9891	PASS	5499.9919	PASS
10	120	5499.9988	PASS	5500.0023	PASS	5500.0014	PASS	5500.0017	PASS
0	120	5500.0175	PASS	5500.013	PASS	5500.0143	PASS	5500.014	PASS
-10	120	5500.0019	PASS	5500.0028	PASS	5500.0027	PASS	5500.0014	PASS
-20	120	5499.9965	PASS	5499.9953	PASS	5499.9972	PASS	5499.9935	PASS
-30	120	5500.0082	PASS	5500.0108	PASS	5500.0069	PASS	5500.0057	PASS

Frequency Stability Versus Voltage									
Operating Frequency: 5500 MHz									
TEMP. (°C)	Power Supply (Vac)	0 Minute		2 Minute		5 Minute		10 Minute	
		Measured Frequency (MHz)	Pass/Fail	Measured Frequency (MHz)	Pass/Fail	Measured Frequency (MHz)	Pass/Fail	Measured Frequency (MHz)	Pass/Fail
20	138	5499.992	PASS	5499.9925	PASS	5499.9895	PASS	5499.9914	PASS
	120	5499.9917	PASS	5499.993	PASS	5499.9891	PASS	5499.9919	PASS
	102	5499.9925	PASS	5499.9932	PASS	5499.9891	PASS	5499.9912	PASS

4.7 6dB Bandwidth Measurement

4.7.1 Limits of 6dB Bandwidth Measurement

The minimum of 6dB Bandwidth Measurement is 0.5MHz.

4.7.2 Test Setup

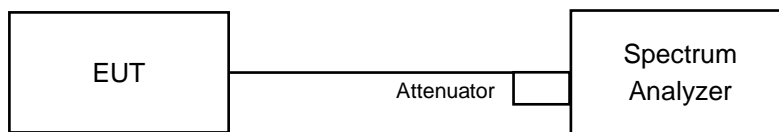

4.7.3 Test Instruments

Refer to section 4.1.2 to get information of above instrument.

4.7.4 Test Procedure

MEASUREMENT PROCEDURE REF

- Set resolution bandwidth (RBW) = 100kHz
- Set the video bandwidth (VBW) $\geq 3 \times$ RBW, Detector = Peak.
- Trace mode = max hold.
- Sweep = auto couple.
- Measure the maximum width of the emission that is constrained by the frequencies associated with the two amplitude points (upper and lower) that are attenuated by 6 dB relative to the maximum level measured in the fundamental emission

4.7.5 Deviation from Test Standard

No deviation.

4.7.6 EUT Operating Condition

The software provided by client to enable the EUT under transmission condition continuously at lowest, middle and highest channel frequencies individually.

4.7.7 Test Results (Mode 1)

802.11a

Channel	Frequency (MHz)	6dB Bandwidth (MHz)				Minimum Limit (MHz)	Pass / Fail
		Chain 0	Chain 1	Chain 2	Chain 3		
144 (UNII-3 Band)	5720	3.17	3.17	3.18	3.17	0.5	Pass

802.11ac (VHT20)

Channel	Frequency (MHz)	6dB Bandwidth (MHz)				Minimum Limit (MHz)	Pass / Fail
		Chain 0	Chain 1	Chain 2	Chain 3		
144 (UNII-3 Band)	5720	3.79	3.79	3.79	3.82	0.5	Pass

802.11ac (VHT40)

Channel	Frequency (MHz)	6dB Bandwidth (MHz)				Minimum Limit (MHz)	Pass / Fail
		Chain 0	Chain 1	Chain 2	Chain 3		
142 (UNII-3 Band)	5710	3.24	3.23	3.20	3.20	0.5	Pass

802.11ac (VHT80)

Channel	Frequency (MHz)	6dB Bandwidth (MHz)				Minimum Limit (MHz)	Pass / Fail
		Chain 0	Chain 1	Chain 2	Chain 3		
138 (UNII-3 Band)	5690	3.22	3.25	2.79	3.21	0.5	Pass

Spectrum Plot of Worst Value

802.11a / Chain 0 - CH144 (UNII-3 Band)

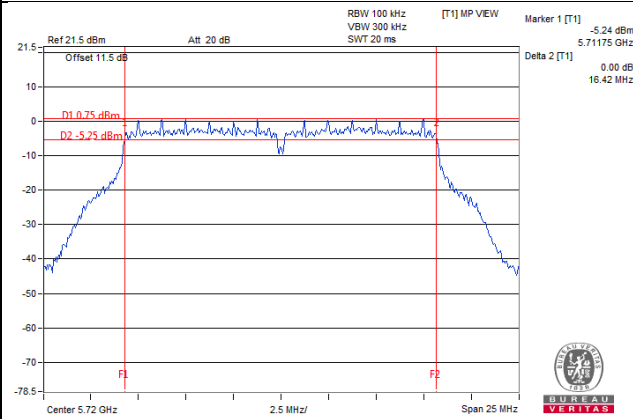

802.11ac (VHT20) / Chain 0 - CH144 (UNII-3 Band)

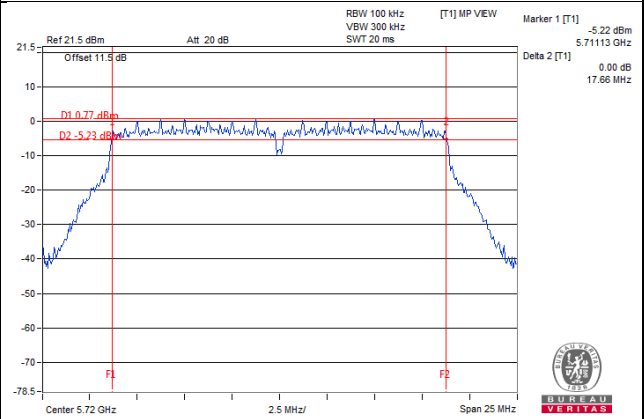

802.11ac (VHT40) / Chain 2 - CH142 (UNII-3 Band)

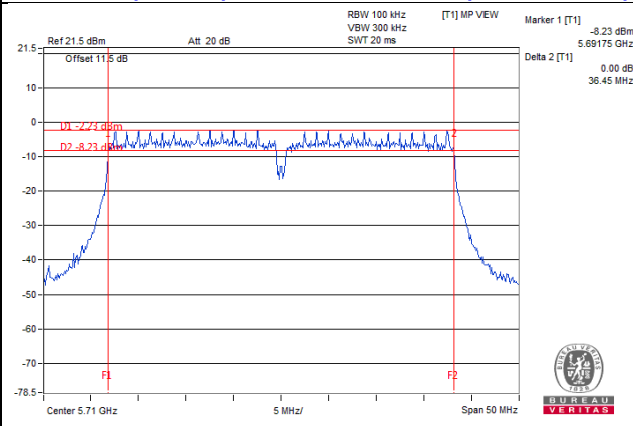

802.11ac (VHT80) / Chain 2 - CH138 (UNII-3 Band)

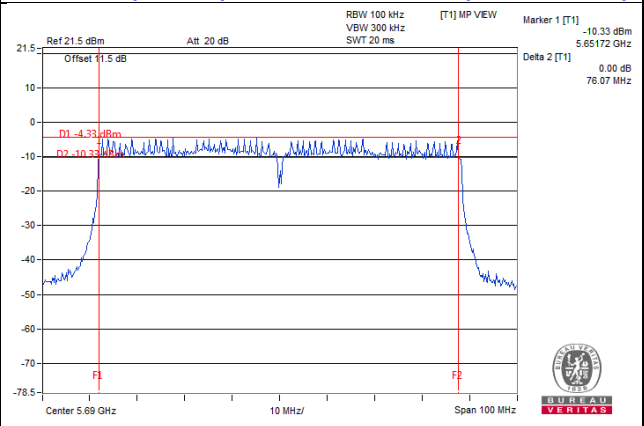

Note: The 6dB bandwidth above 5725MHz = Marker 1 + Delta 2 - 5725MHz

4.7.8 Test Results (Mode 2)

802.11a

Channel	Frequency (MHz)	6dB Bandwidth (MHz)			Minimum Limit (MHz)	Pass / Fail
		Chain 0	Chain 1	Chain 2		
144 (UNII-3 Band)	5720	3.18	3.17	3.17	0.5	Pass

802.11ac (VHT20)

Channel	Frequency (MHz)	6dB Bandwidth (MHz)			Minimum Limit (MHz)	Pass / Fail
		Chain 0	Chain 1	Chain 2		
144 (UNII-3 Band)	5720	3.81	3.78	3.81	0.5	Pass

802.11ac (VHT40)

Channel	Frequency (MHz)	6dB Bandwidth (MHz)			Minimum Limit (MHz)	Pass / Fail
		Chain 0	Chain 1	Chain 2		
142 (UNII-3 Band)	5710	3.22	3.21	3.21	0.5	Pass

802.11ac (VHT80)

Channel	Frequency (MHz)	6dB Bandwidth (MHz)			Minimum Limit (MHz)	Pass / Fail
		Chain 0	Chain 1	Chain 2		
138 (UNII-3 Band)	5690	3.23	3.11	3.21	0.5	Pass

Spectrum Plot of Worst Value

802.11a_Chain 1 / CH144 (UNII-3 Band)

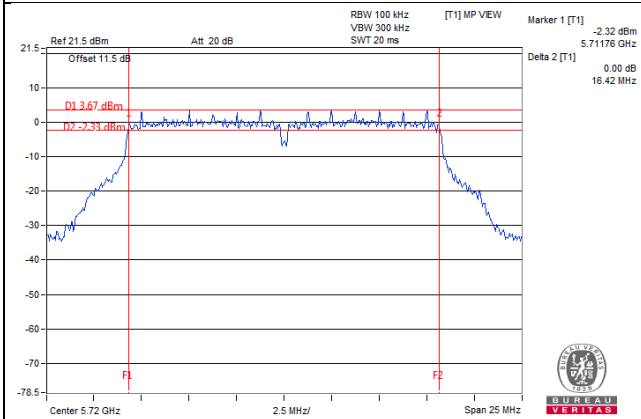

802.11ac (VHT20)_Chain 1 / CH144 (UNII-3 Band)

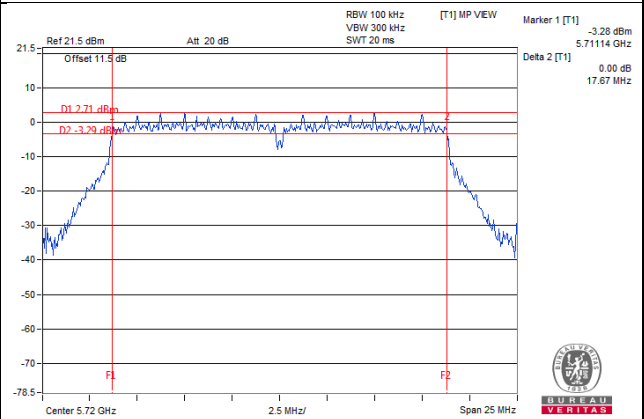

802.11ac (VHT40)_Chain 1 / CH142 (UNII-3 Band)

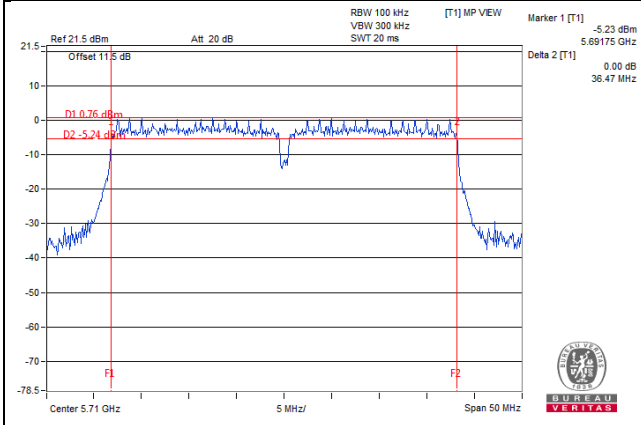

802.11ac (VHT80)_Chain 1 / CH138 (UNII-3 Band)

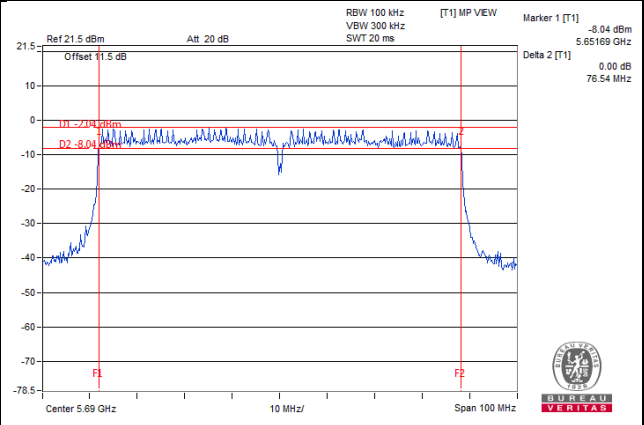

Note: The 6dB bandwidth above 5725MHz = Marker 1 + Delta 2 - 5725MHz

4.7.9 Test Results (Mode 3)

802.11a

Channel	Frequency (MHz)	6dB Bandwidth (MHz)		Minimum Limit (MHz)	Pass / Fail
		Chain 2	Chain 3		
144 (UNII-3 Band)	5720	3.14	3.16	0.5	Pass

802.11ac (VHT20)

Channel	Frequency (MHz)	6dB Bandwidth (MHz)		Minimum Limit (MHz)	Pass / Fail
		Chain 2	Chain 3		
144 (UNII-3 Band)	5720	3.78	3.79	0.5	Pass

802.11ac (VHT40)

Channel	Frequency (MHz)	6dB Bandwidth (MHz)		Minimum Limit (MHz)	Pass / Fail
		Chain 2	Chain 3		
142 (UNII-3 Band)	5710	3.21	3.22	0.5	Pass

802.11ac (VHT80)

Channel	Frequency (MHz)	6dB Bandwidth (MHz)		Minimum Limit (MHz)	Pass / Fail
		Chain 2	Chain 3		
138 (UNII-3 Band)	5690	3.23	3.21	0.5	Pass

Spectrum Plot of Worst Value

802.11a / Chain 2 - CH144 (UNII-3 Band)

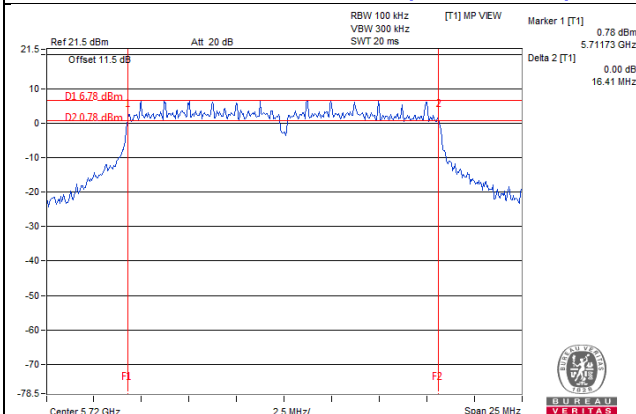

802.11ac (VHT20) / Chain 2 - CH144 (UNII-3 Band)

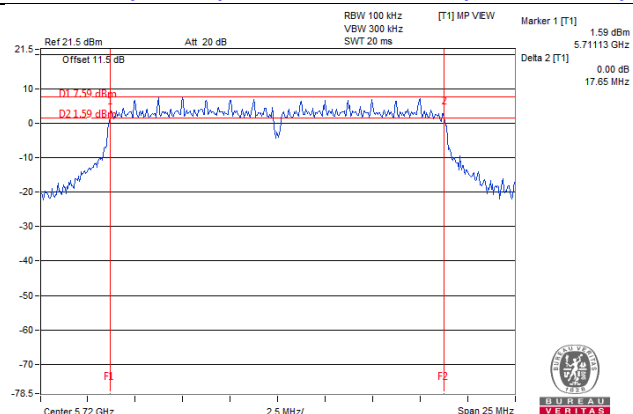

802.11ac (VHT40) / Chain 2 - CH142 (UNII-3 Band)

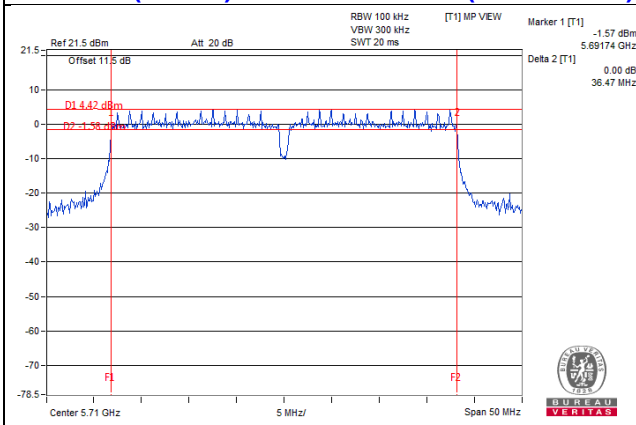

802.11ac (VHT80) / Chain 3 - CH138 (UNII-3 Band)

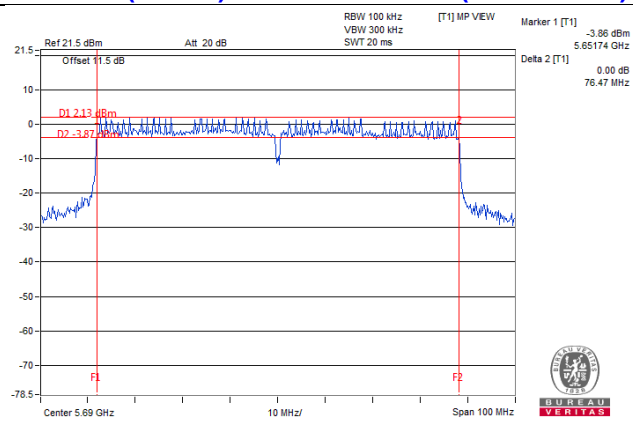

Note: The 6dB bandwidth above 5725MHz = Marker 1 + Delta 2 - 5725MHz

4.7.10 Test Results (Mode 4)

802.11a

Channel	Frequency (MHz)	6dB Bandwidth (MHz)	Minimum Limit (MHz)	Pass / Fail
144 (UNII-3 Band)	5720	3.18	0.5	PASS

802.11ac (VHT20)

Channel	Frequency (MHz)	6dB Bandwidth (MHz)	Minimum Limit (MHz)	Pass / Fail
144 (UNII-3 Band)	5720	3.82	0.5	PASS

802.11ac (VHT40)

Channel	Frequency (MHz)	6dB Bandwidth (MHz)	Minimum Limit (MHz)	Pass / Fail
142 (UNII-3 Band)	5710	3.22	0.5	PASS

802.11ac (VHT80)

Channel	Frequency (MHz)	6dB Bandwidth (MHz)	Minimum Limit (MHz)	Pass / Fail
138 (UNII-3 Band)	5690	2.87	0.5	PASS

Spectrum Plot of Worst Value

802.11a / CH144 (UNII-3 Band)

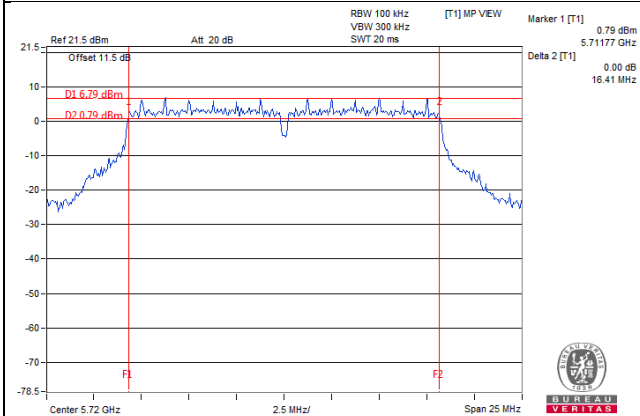

802.11ac (VHT20) / CH144 (UNII-3 Band)

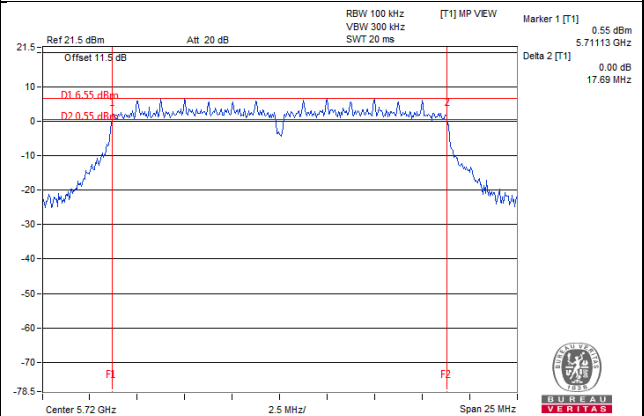

802.11ac (VHT40) / CH142 (UNII-3 Band)

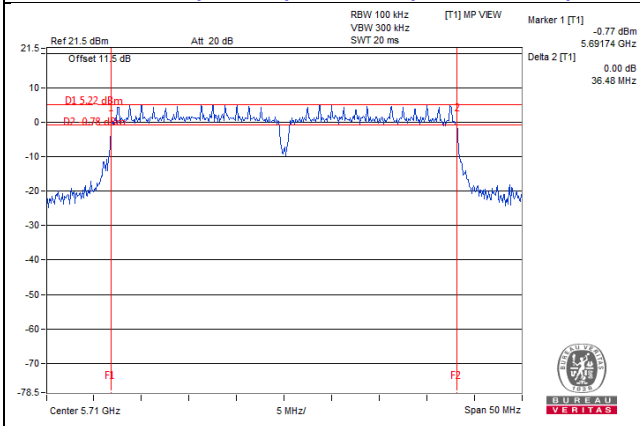

802.11ac (VHT80) / CH138 (UNII-3 Band)

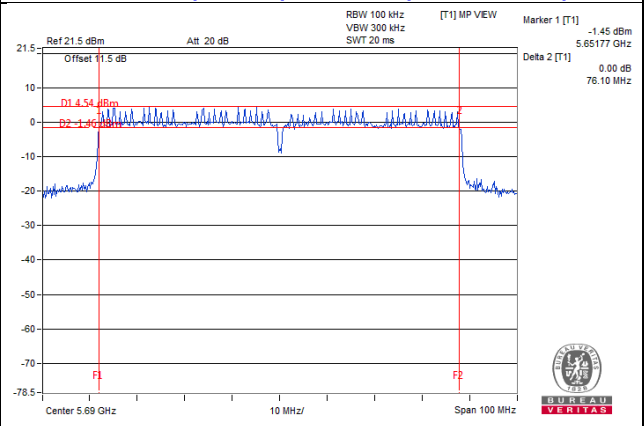

Note: The 6dB bandwidth above 5725MHz = Marker 1 + Delta 2 - 5725MHz

5 Pictures of Test Arrangements

Please refer to the attached file (Test Setup Photo).

Appendix – Information on the Testing Laboratories

We, Bureau Veritas Consumer Products Services (H.K.) Ltd., Taoyuan Branch, were founded in 1988 to provide our best service in EMC, Radio, Telecom and Safety consultation. Our laboratories are accredited and approved according to ISO/IEC 17025.

If you have any comments, please feel free to contact us at the following:

Linko EMC/RF Lab

Tel: 886-2-26052180

Fax: 886-2-26051924

Hsin Chu EMC/RF/Telecom Lab

Tel: 886-3-6668565

Fax: 886-3-6668323

Hwa Ya EMC/RF/Safety Lab

Tel: 886-3-3183232

Fax: 886-3-3270892

Email: service.adt@tw.bureauveritas.com

Web Site: www.bureauveritas-adt.com

The address and road map of all our labs can be found in our web site also.

--- END ---