

Partial FCC Test Report

Report No.: RF151230E03O

FCC ID: 2AHBN-AP41

Test Model: AP41

Series Model: AP41E

Received Date: Jun. 26, 2019

Test Date: Jul. 02 ~ Aug. 05, 2019

Issued Date: Aug. 13, 2019

Applicant: Mist Systems, Inc.

Address: 1601 South De Anza Blvd. Suite 248 Cupertino California United States
95014

Issued By: Bureau Veritas Consumer Products Services (H.K.) Ltd., Taoyuan Branch
Lin Kou Laboratories

Lab Address: No. 47-2, 14th Ling, Chia Pau Vil., Lin Kou Dist., New Taipei City, Taiwan
(R.O.C.)

Test Location: No. 19, Hwa Ya 2nd Rd., Wen Hwa Vil., Kwei Shan Dist., Taoyuan City
33383, TAIWAN (R.O.C.)

**FCC Registration /
Designation Number:** 788550 / TW0003



This report is for your exclusive use. Any copying or replication of this report to or for any other person or entity, or use of our name or trademark, is permitted only with our prior written permission. This report sets forth our findings solely with respect to the test samples identified herein. The results set forth in this report are not indicative or representative of the quality or characteristics of the lot from which a test sample was taken or any similar or identical product specifically and expressly noted. Our report includes all of the tests requested by you and the results thereof based upon the information that you provided to us. You have 60 days from date of issuance of this report to notify us of any material error or omission caused by our negligence, provided, however, that such notice shall be in writing and shall specifically address the issue you wish to raise. A failure to raise such issue within the prescribed time shall constitute your unqualified acceptance of the completeness of this report, the tests conducted and the correctness of the report contents. Unless specific mention, the uncertainty of measurement has been explicitly taken into account to declare the compliance or non-compliance to the specification. This report should not be used by the client to claim product certification, approval, or endorsement by TAF or any government agencies.

Table of Contents

Release Control Record	3
1 Certificate of Conformity	4
2 Summary of Test Results	5
2.1 Measurement Uncertainty.....	5
2.2 Modification Record.....	5
3 General Information	6
3.1 General Description of EUT.....	6
3.2 Description of Test Modes.....	8
3.2.1 Test Mode Applicability and Tested Channel Detail.....	9
3.3 Duty Cycle of Test Signal.....	11
3.4 Description of Support Units.....	12
3.4.1 Configuration of System under Test.....	12
3.5 General Description of Applied Standards.....	13
4 Test Types and Results	14
4.1 Radiated Emission and Bandedge Measurement.....	14
4.1.1 Limits of Radiated Emission and Bandedge Measurement.....	14
4.1.2 Test Instruments.....	15
4.1.3 Test Procedures.....	16
4.1.4 Deviation from Test Standard.....	16
4.1.5 Test Setup.....	17
4.1.6 EUT Operating Conditions.....	18
4.1.7 Test Results.....	19
4.2 Conducted Emission Measurement.....	35
4.2.1 Limits of Conducted Emission Measurement.....	35
4.2.2 Test Instruments.....	35
4.2.3 Test Procedures.....	36
4.2.4 Deviation from Test Standard.....	36
4.2.5 Test Setup.....	36
4.2.6 EUT Operating Conditions.....	36
4.2.7 Test Results.....	37
4.3 Conducted Output Power Measurement.....	41
4.3.1 Limits of Conducted Output Power Measurement.....	41
4.3.2 Test Setup.....	41
4.3.3 Test Instruments.....	41
4.3.4 Test Procedures.....	41
4.3.5 Deviation from Test Standard.....	41
4.3.6 EUT Operating Conditions.....	41
4.3.7 Test Results.....	42
4.4 Power Spectral Density Measurement.....	48
4.4.1 Limits of Power Spectral Density Measurement.....	48
4.4.2 Test Setup.....	48
4.4.3 Test Instruments.....	48
4.4.4 Test Procedure.....	48
4.4.5 Deviation from Test Standard.....	48
4.4.6 EUT Operating Condition.....	48
4.4.7 Test Results.....	49
5 Pictures of Test Arrangements	60
Appendix – Information of the Testing Laboratories	61

Release Control Record

Issue No.	Description	Date Issued
RF151230E03O	Original release.	Aug. 13, 2019

1 Certificate of Conformity

Product: Premium Wi-Fi & BLE Array AP
Brand: Mist
Test Model: AP41
Series Model: AP41E
Sample Status: Engineering sample
Applicant: Mist Systems, Inc.
Test Date: Jul. 02 ~ Aug. 05, 2019
Standards: 47 CFR FCC Part 15, Subpart C (Section 15.247)
ANSI C63.10:2013

The above equipment has been tested by **Bureau Veritas Consumer Products Services (H.K.) Ltd., Taoyuan Branch**, and found compliance with the requirement of the above standards. The test record, data evaluation & Equipment Under Test (EUT) configurations represented herein are true and accurate accounts of the measurements of the sample's RF characteristics under the conditions specified in this report.

Prepared by : Pettie Chen , **Date:** Aug. 13, 2019
Pettie Chen / Senior Specialist

Approved by : Bruce Chen , **Date:** Aug. 13, 2019
Bruce Chen / Senior Project Engineer

2 Summary of Test Results

47 CFR FCC Part 15, Subpart C (Section 15.247)			
FCC Clause	Test Item	Result	Remarks
15.207	AC Power Conducted Emission	Pass	Meet the requirement of limit. Minimum passing margin is -11.36dB at 0.15000MHz.
15.205 / 15.209 / 15.247(d)	Radiated Emissions and Band Edge Measurement	Pass	Meet the requirement of limit. Minimum passing margin is -1.1dB at 2390.00MHz and 2483.50MHz.
15.247(b)	Conducted power	Pass	Meet the requirement of limit.
15.247(e)	Power Spectral Density	Pass	Meet the requirement of limit.
15.203	Antenna Requirement	Pass	For internal antenna: Antenna connector is IPEX not a standard connector. For external antenna: Antenna connector is Reverse SMA Male not a standard connector.

Note: Determining compliance based on the results of the compliance measurement, not taking into account measurement instrumentation uncertainty.

2.1 Measurement Uncertainty

Where relevant, the following measurement uncertainty levels have been estimated for tests performed on the EUT as specified in CISPR 16-4-2:

Measurement	Frequency	Expanded Uncertainty (k=2) (±)
Conducted Emissions at mains ports	150kHz ~ 30MHz	2.94 dB
Radiated Emissions up to 1 GHz	9kHz ~ 30MHz	3.04 dB
	30MHz ~ 200MHz	3.86 dB
	200MHz ~ 1000MHz	3.87 dB
Radiated Emissions above 1 GHz	1GHz ~ 18GHz	2.29 dB
	18GHz ~ 40GHz	2.29 dB

2.2 Modification Record

There were no modifications required for compliance.

3 General Information

3.1 General Description of EUT

Product	Premium Wi-Fi & BLE Array AP
Brand	Mist
Test Model	AP41
Series Model	AP41E
Model Difference	AP41 for internal antenna AP41E for external antenna
Sample Status	Engineering sample
Power Supply Rating	12Vdc from adapter 55Vdc from PoE
Modulation Type	CCK, DQPSK, DBPSK for DSSS 256QAM, 64QAM, 16QAM, QPSK, BPSK for OFDM
Modulation Technology	DSSS, OFDM
Transfer Rate	802.11b: 11.0/ 5.5/ 2.0/ 1.0Mbps 802.11g: 54.0/ 48.0/ 36.0/ 24.0/ 18.0/ 12.0/ 9.0/ 6.0Mbps 802.11n: up to 800.0Mbps with 256QAM
Operating Frequency	2412~2462MHz
Number of Channel	802.11b, 802.11g, 802.11n (HT20): 11 802.11n (HT40): 7
Output Power	CDD Mode: 1TX: 90.573mW 2TX: 201.235mW 3TX: 317.648mW 4TX: 416.960mW Beamforming Mode: 2TX: 73.227mW 3TX: 116.082mW 4TX: 153.839mW
Antenna Type	Refer to Note
Antenna Connector	Refer to Note
Accessory Device	N/A
Data Cable Supplied	N/A

Note:

1. This report is prepared for FCC class II permissive change. This report is issued as a supplementary report of the original report no.: RF151230E03B. The differences compared with original report are adding a new antenna for the EUT with external antenna and changing software but not impact DFS parameter. AC Power Conducted Emission, Radiated Emissions, Conducted power and Power Spectral Density tests for the external antenna are performed for the addendum.
2. There are three radios for the EUT.

Radio	Brand	Model	Function
Radio 1	Broadcom	BCM43465	WLAN 2.4G & 5G
Radio 2	Broadcom	BCM43465	WLAN 2.4G & 5G
Radio 3	Broadcom	BCM20704	BT EDR & BT LE

3. The EUT incorporates a MIMO function. Physically, the EUT provides 4 completed transmitters and 4 receivers.

Modulation Mode	TX Function	Beamforming
Radio 1		
802.11b	1TX/2TX/3TX/4TX	Not Support
802.11g	1TX/2TX/3TX/4TX	Not Support
802.11n (HT20)/(VHT20)	1TX/2TX/3TX/4TX	Support
802.11n (HT40)/(VHT40)	1TX/2TX/3TX/4TX	Support
Radio 2		
802.11b	1TX	Not Support
802.11g	1TX	Not Support
802.11n (HT20)	1TX	Not Support
802.11n (HT40)	1TX	Not Support

*The worst case of Radio 1 is beamforming on mode for the final tests.

*The worst configuration is as below.

Mode	Chain
Radio 1 / 1TX	Chain 0
Radio 1 / 2TX	Chain 0 + 1
Radio 1 / 3TX	Chain 0 + 1 + 2
Radio 1 / 4TX	Chain 0 + 1 + 2 + 3

*After estimating, 4TX is the worst case for the final tests.

4. The EUT uses following adapter & PoE. (Support unit only)

Adapter	
Brand	Channel Well Technology
Model	2ABN036F US
Input Power	100-240Vac~50/60Hz 1.0A
Output Power	12.0Vdc / 3.0A
Power Line	1.45m DC cable without core attached on adapter

PoE	
Brand	Microsemi
Model	PD-9001GR/AT/AC
Input Power	100-240Vac~50/60Hz 0.67A
Output Power	55Vdc / 0.6A

5. The following antennas were provided to the EUT. (Antenna 3 was the new antenna)

Antenna 1					
Antenna Type	PIFA				
Antenna Connector	IPEX				
Gain (dBi)	Frequency				
	2.4~2.4835GHz	5.15~5.25GHz	5.25~5.35GHz	5.47~5.725GHz	5.725~5.85GHz
Int. WIFI Ant. 1	3.06	3.85	3.97	4.21	4.18
Int. WIFI Ant. 2	3.64	4.49	4.21	3.27	3.99
Int. WIFI Ant. 3	3.37	3.50	4.04	4.14	4.34
Int. WIFI Ant. 4	3.54	3.87	3.77	4.02	4.17
Scanning Radio Ant.	3.61	3.59	4.21	4.43	4.29

Antenna 2					
Antenna Type	Patch				
Antenna Connector	RPSMA				
Gain (dBi)	Frequency				
	2.4~2.4835GHz	5.15~5.25GHz	5.25~5.35GHz	5.47~5.725GHz	5.725~5.85GHz
Ext. WIFI Ant.	4	6	6	6	6

*Int. WIFI Ant. 1~4, Ext. WIFI Ant. were for Radio 1.

*Scanning Radio Ant. was for Radio 2

Antenna 3 (New)		
Antenna Type	Patch	
Antenna Connector	Reverse SMA Male	
Gain (dBi)	Frequency	
	2400~2500MHz	5150~5900MHz
Ext. WIFI Ant.	8	8

*The Ext. WIFI Ant. were for Radio 1.

3.2 Description of Test Modes

11 channels are provided for 802.11b, 802.11g and 802.11n (HT20):

Channel	Frequency	Channel	Frequency
1	2412MHz	7	2442MHz
2	2417MHz	8	2447MHz
3	2422MHz	9	2452MHz
4	2427MHz	10	2457MHz
5	2432MHz	11	2462MHz
6	2437MHz		

7 channels are provided for 802.11n (HT40):

Channel	Frequency	Channel	Frequency
3	2422MHz	7	2442MHz
4	2427MHz	8	2447MHz
5	2432MHz	9	2452MHz
6	2437MHz		

3.2.1 Test Mode Applicability and Tested Channel Detail

EUT Configure Mode	Applicable to				Description
	RE \geq 1G	RE<1G	PLC	APCM	
A	-	√	√	√	Radio 1 (Power from adapter)
B	√	√	√	-	Radio 1 (Power from PoE)

Where RE \geq 1G: Radiated Emission above 1GHz & Bandedge Measurement
 RE<1G: Radiated Emission below 1GHz
 PLC: Power Line Conducted Emission
 APCM: Antenna Port Conducted Measurement

Note:

1. The antenna had been pre-tested on the positioned of each 3 axis. The worst case was found when positioned on Z-plane.
2. "-" means no effect.

Radiated Emission Test (Above 1GHz):

- Pre-Scan has been conducted to determine the worst-case mode from all possible combinations between available modulations, data rates and antenna ports (if EUT with antenna diversity architecture).
- Following channel(s) was (were) selected for the final test as listed below.

EUT Configure Mode	Mode	Available Channel	Tested Channel	Modulation Technology	Modulation Type	Data Rate (Mbps)	Remark
B	802.11b	1 to 11	1, 6, 11	DSSS	DBPSK	1.0	-
	802.11g	1 to 11	1, 6, 11	OFDM	BPSK	6.0	-
	802.11n (HT20)	1 to 11	1, 6, 11	OFDM	BPSK	6.5	-
	802.11n (HT40)	3 to 9	3, 6, 9	OFDM	BPSK	13.5	-

Radiated Emission Test (Below 1GHz):

- Pre-Scan has been conducted to determine the worst-case mode from all possible combinations between available modulations, data rates and antenna ports (if EUT with antenna diversity architecture).
- Following channel(s) was (were) selected for the final test as listed below.

EUT Configure Mode	Mode	Available Channel	Tested Channel	Modulation Technology	Modulation Type	Data Rate (Mbps)	Remark
A, B	802.11g	1 to 11	6	OFDM	BPSK	6.0	-

Power Line Conducted Emission Test:

- Pre-Scan has been conducted to determine the worst-case mode from all possible combinations between available modulations, data rates and antenna ports (if EUT with antenna diversity architecture).
- Following channel(s) was (were) selected for the final test as listed below.

EUT Configure Mode	Mode	Available Channel	Tested Channel	Modulation Technology	Modulation Type	Data Rate (Mbps)	Remark
A, B	802.11g	1 to 11	6	OFDM	BPSK	6.0	-

Antenna Port Conducted Measurement:

- This item includes all test value of each mode, but only includes spectrum plot of worst value of each mode.
- Pre-Scan has been conducted to determine the worst-case mode from all possible combinations between available modulations, data rates and antenna ports (if EUT with antenna diversity architecture).
- Following channel(s) was (were) selected for the final test as listed below.

EUT Configure Mode	Mode	Available Channel	Tested Channel	Modulation Technology	Modulation Type	Data Rate (Mbps)	Remark
A	802.11b	1 to 11	1, 6, 11	DSSS	DBPSK	1.0	-
	802.11g	1 to 11	1, 6, 11	OFDM	BPSK	6.0	-
	802.11n (HT20)	1 to 11	1, 6, 11	OFDM	BPSK	6.5	-
	802.11n (HT40)	3 to 9	3, 6, 9	OFDM	BPSK	13.5	-

Test Condition:

Applicable to	Environmental Conditions	Input Power	Tested by
RE \geq 1G	25 deg. C, 68% RH	120Vac, 60Hz	Titan Hsu
RE<1G	23 deg. C, 67% RH	120Vac, 60Hz	Adair Peng
PLC	24 deg. C, 66% RH	120Vac, 60Hz	Willy Cheng
APCM	25 deg. C, 60% RH	120Vac, 60Hz	Leo Tsai

3.3 Duty Cycle of Test Signal

Duty cycle of test signal is < 98%, duty factor is required.

802.11b: Duty cycle = $12.374/13.199 = 0.937$, Duty factor = $10 * \log(1/0.937) = 0.28$

802.11g: Duty cycle = $2.049/2.172 = 0.943$, Duty factor = $10 * \log(1/0.943) = 0.25$

802.11n (HT20): Duty cycle = $1.91/2.032 = 0.940$, Duty factor = $10 * \log(1/0.940) = 0.27$

802.11n (HT40): Duty cycle = $0.932/1.042 = 0.894$, Duty factor = $10 * \log(1/0.894) = 0.48$

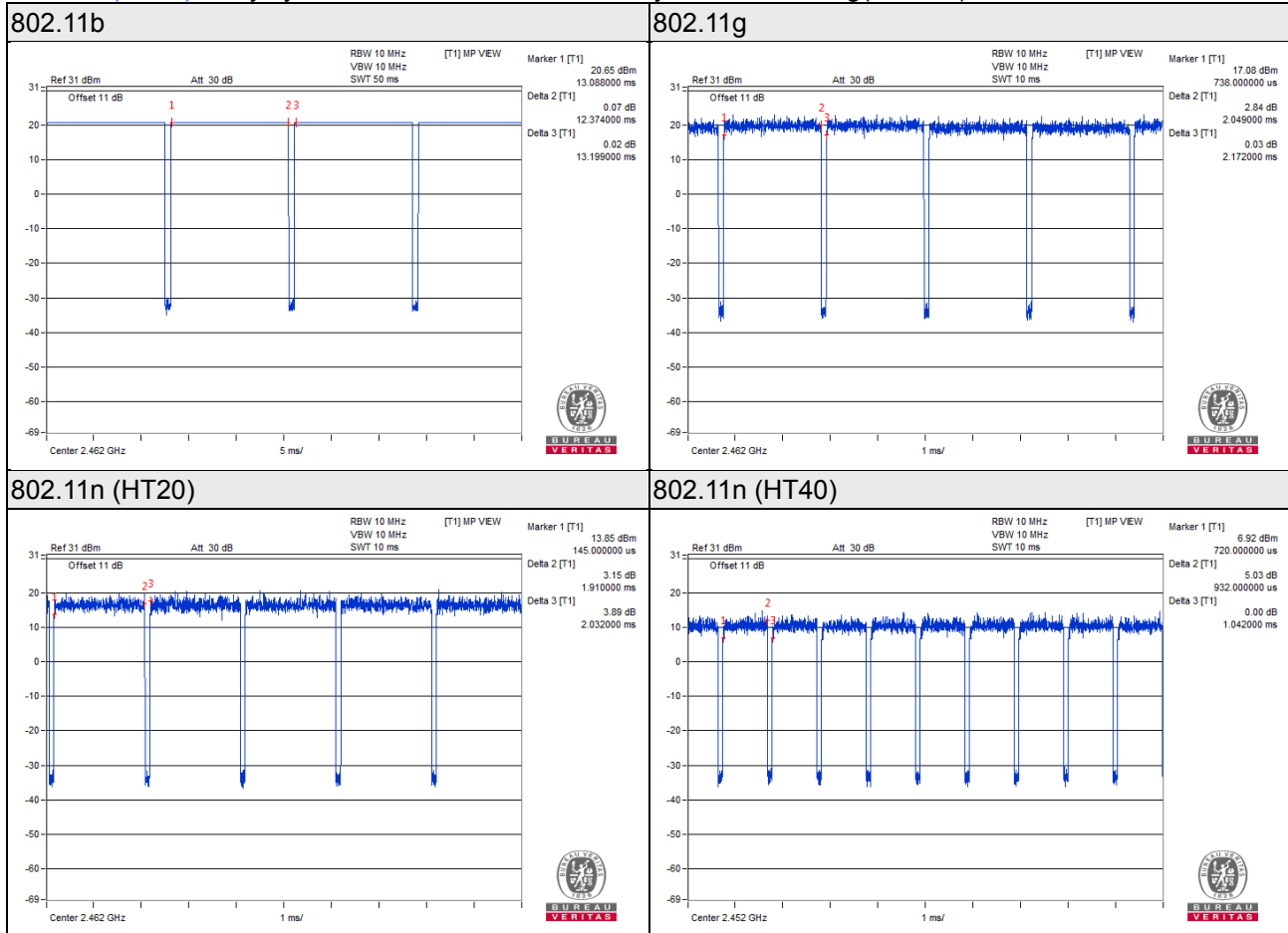

3.4 Description of Support Units

The EUT has been tested as an independent unit together with other necessary accessories or support units. The following support units or accessories were used to form a representative test configuration during the tests.

ID	Product	Brand	Model No.	Serial No.	FCC ID	Remarks
A.	Notebook	DELL	E5410	1HC2XM1	FCC DoC Approved	-
B.	USB 3.0 Flash Drive	HP	v250W	01	FCC DoC Approved	-
C.	Adapter	Channel Well Technology	2ABN036F US	N/A	N/A	Provided by client
D.	Load	N/A	N/A	N/A	N/A	-
E.	PoE	Microsemi	PD-9001GR/AT/AC	N/A	N/A	Provided by client

Note:

1. All power cords of the above support units are non-shielded (1.8m).
2. Items A acted as communication partners to transfer data.

ID	Descriptions	Qty.	Length (m)	Shielding (Yes/No)	Cores (Qty.)	Remarks
1.	RJ45 cable	1	6.0	N	0	-
2.	RJ45 cable	2	1.5	N	0	-
3.	DC cable	1	1.45	-	0	attached on adapter
4.	RJ45 cable	1	3	N	0	-

Note: The core(s) is(are) originally attached to the cable(s).

3.4.1 Configuration of System under Test

Test Mode A

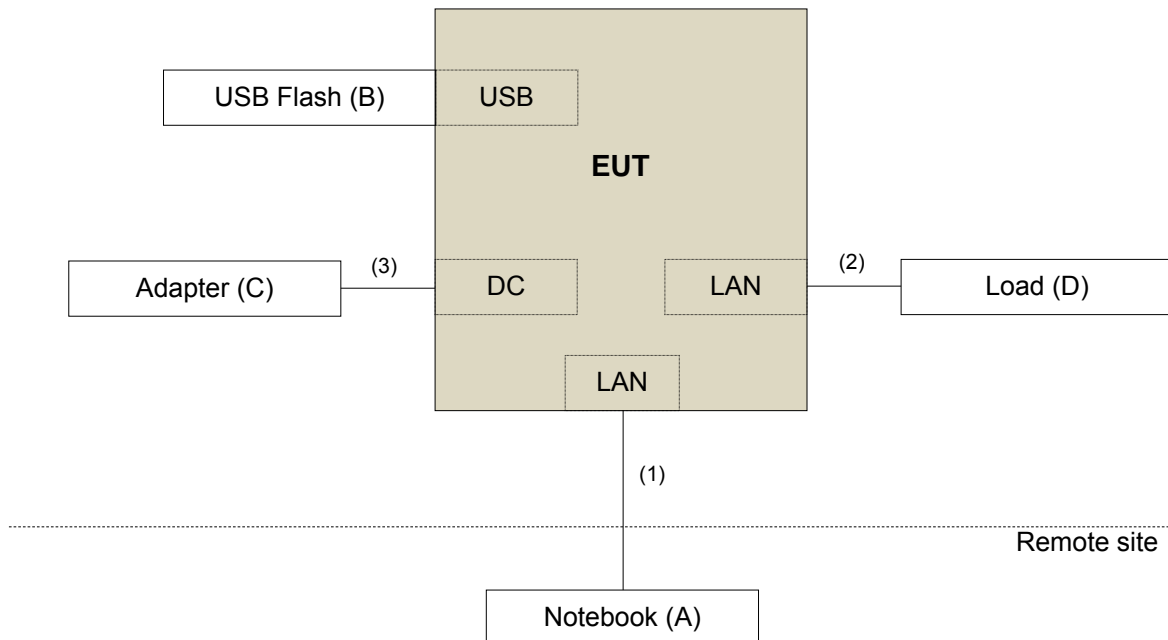

Test Mode B

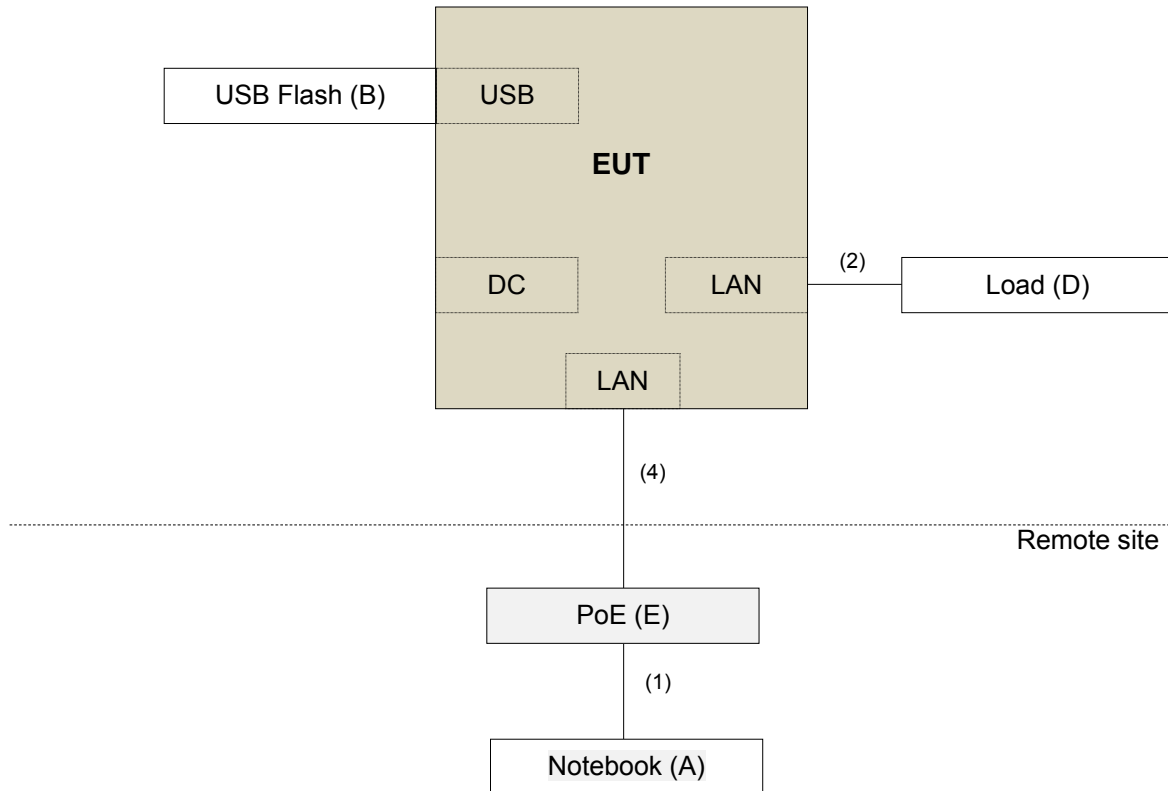

3.5 General Description of Applied Standards

The EUT is a RF Product. According to the specifications of the manufacturer, it must comply with the requirements of the following standards:

FCC Part 15, Subpart C (15.247)

KDB 558074 D01 15.247 Meas Guidance v05r02

KDB 662911 D01 Multiple Transmitter Output v02r01

ANSI C63.10-2013

All test items have been performed and recorded as per the above standards.

4 Test Types and Results

4.1 Radiated Emission and Bandedge Measurement

4.1.1 Limits of Radiated Emission and Bandedge Measurement

Radiated emissions which fall in the restricted bands must comply with the radiated emission limits specified as below table. Other emissions shall be at least 30dB below the highest level of the desired power:

Frequencies (MHz)	Field Strength (microvolts/meter)	Measurement Distance (meters)
0.009 ~ 0.490	2400/F(kHz)	300
0.490 ~ 1.705	24000/F(kHz)	30
1.705 ~ 30.0	30	30
30 ~ 88	100	3
88 ~ 216	150	3
216 ~ 960	200	3
Above 960	500	3

Note:

1. The lower limit shall apply at the transition frequencies.
2. Emission level (dBuV/m) = 20 log Emission level (uV/m).
3. For frequencies above 1000MHz, the field strength limits are based on average detector, however, the peak field strength of any emission shall not exceed the maximum permitted average limits, specified above by more than 20dB under any condition of modulation.

4.1.2 Test Instruments

Description & Manufacturer	Model No.	Serial No.	Cal. Date	Cal. Due
Test Receiver ROHDE & SCHWARZ	ESIB7	100187	May 30, 2019	May 29, 2020
Spectrum Analyzer SCHWARZBECK	FSP40	100269	Jun. 10, 2019	Jun. 09, 2020
BILOG Antenna SCHWARZBECK	VULB9168	9168-171	Nov. 22, 2018	Nov. 21, 2019
HORN Antenna SCHWARZBECK	9120D	209	Nov. 25, 2018	Nov. 24, 2019
HORN Antenna SCHWARZBECK	BBHA 9170	BBHA9170241	Nov. 25, 2018	Nov. 24, 2019
Preamplifier Agilent (Below 1GHz)	8447D	2944A10738	Aug. 21, 2018	Aug. 20, 2019
Preamplifier Agilent (Above 1GHz)	8449B	3008A02465	Mar. 27, 2019	Mar. 26, 2020
RF signal cable HUBER+SUHNER	SUCOFLEX 104	Cable-CH3-03 (223653/4)	Aug. 21, 2018	Aug. 20, 2019
RF signal cable HUBER+SUHNER& EMCI	SUCOFLEX 104&EMC104-SM-SM- 8000	Cable-CH3-03 (309224+170907)	Aug. 21, 2018	Aug. 20, 2019
RF signal cable WOKEN	8D-FB	Cable-CH3-01	Aug. 21, 2018	Aug. 20, 2019
Software BV ADT	ADT_Radiated_ V7.6.15.9.5	NA	NA	NA
Antenna Tower inn-co GmbH	MA 4000	013303	NA	NA
Antenna Tower Controller BV ADT	AT100	AT93021702	NA	NA
Turn Table BV ADT	TT100	TT93021702	NA	NA
Turn Table Controller BV ADT	SC100	SC93021702	NA	NA
Boresight Antenna Fixture	FBA-01	FBA-SIP01	NA	NA
USB Wideband Power Sensor KEYSIGHT	U2021XA	MY55050005/MY551 90004/MY55190007/ MY55210005	Jul. 17, 2018	Jul. 16, 2019
			Jul. 18, 2019	Jul. 17, 2020

Note: 1. The calibration interval of the above test instruments is 12 months and the calibrations are traceable to NML/ROC and NIST/USA.
2. The test was performed in HwaYa Chamber 3.

4.1.3 Test Procedures

For Radiated emission below 30MHz

- a. The EUT was placed on the top of a rotating table 0.8 meters above the ground at a 3 meter chamber room. The table was rotated 360 degrees to determine the position of the highest radiation.
- b. The EUT was set 3 meters away from the interference-receiving antenna, which was mounted on the top of a variable-height antenna tower.
- c. Parallel, perpendicular, and ground-parallel orientations of the antenna are set to make the measurement.
- d. For each suspected emission, the EUT was arranged to its worst case and the rotatable table was turned from 0 degrees to 360 degrees to find the maximum reading.
- e. The test-receiver system was set to Quasi-Peak Detect Function and Specified Bandwidth with Maximum Hold Mode.

Note:

1. The resolution bandwidth and video bandwidth of test receiver/spectrum analyzer is 9kHz at frequency below 30MHz.

For Radiated emission above 30MHz

- a. The EUT was placed on the top of a rotating table 0.8 meters (for 30MHz ~ 1GHz) / 1.5 meters (for above 1GHz) above the ground at 3 meter chamber room for test. The table was rotated 360 degrees to determine the position of the highest radiation.
- b. The EUT was set 3 meters away from the interference-receiving antenna, which was mounted on the top of a variable-height antenna tower.
- c. The height of antenna is varied from one meter to four meters above the ground to determine the maximum value of the field strength. Both horizontal and vertical polarizations of the antenna are set to make the measurement.
- d. For each suspected emission, the EUT was arranged to its worst case and then the antenna was tuned to heights from 1 meter to 4 meters and the rotatable table was turned from 0 degrees to 360 degrees to find the maximum reading.
- e. The test-receiver system was set to quasi-peak detect function and specified bandwidth with maximum hold mode when the test frequency is below 1 GHz.
- f. The test-receiver system was set to peak and average detect function and specified bandwidth with maximum hold mode when the test frequency is above 1 GHz. If the peak reading value also meets average limit, measurement with the average detector is unnecessary.

Note:

1. The resolution bandwidth and video bandwidth of test receiver/spectrum analyzer is 120kHz for Quasi-peak detection (QP) at frequency below 1GHz.
2. The resolution bandwidth of test receiver/spectrum analyzer is 1 MHz and the video bandwidth is 3 MHz for Peak detection (PK) at frequency above 1GHz.
3. The resolution bandwidth of test receiver/spectrum analyzer is 1MHz and the video bandwidth is $\geq 1/T$ (Duty cycle < 98%) or 10Hz (Duty cycle $\geq 98\%$) for Average detection (AV) at frequency above 1GHz.
(802.11b: RBW = 1MHz, VBW = 100Hz; 802.11g: RBW = 1MHz, VBW = 1kHz;
802.11n (HT20): RBW = 1MHz, VBW = 1kHz; 802.11n (HT40): RBW = 1MHz, VBW = 3kHz)
4. All modes of operation were investigated and the worst-case emissions are reported.

4.1.4 Deviation from Test Standard

No deviation.

4.1.5 Test Setup

For Radiated emission below 30MHz

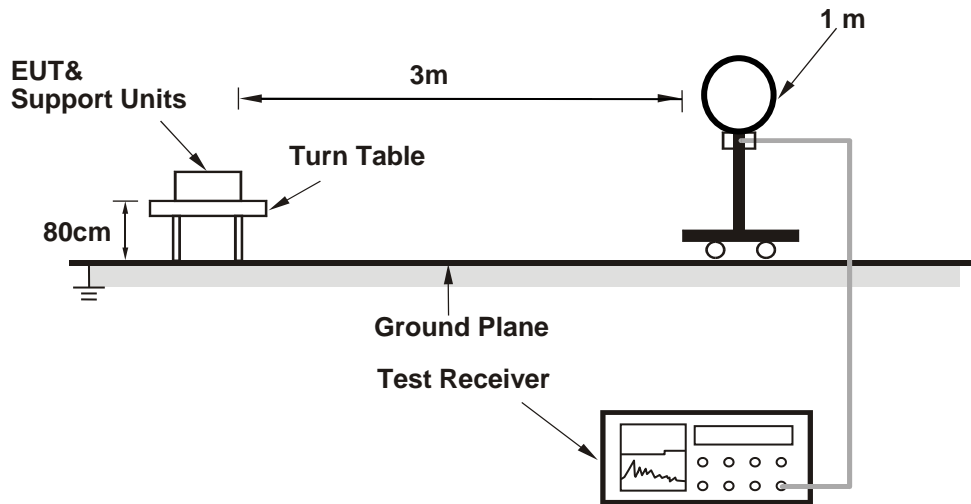

For Radiated emission 30MHz to 1GHz

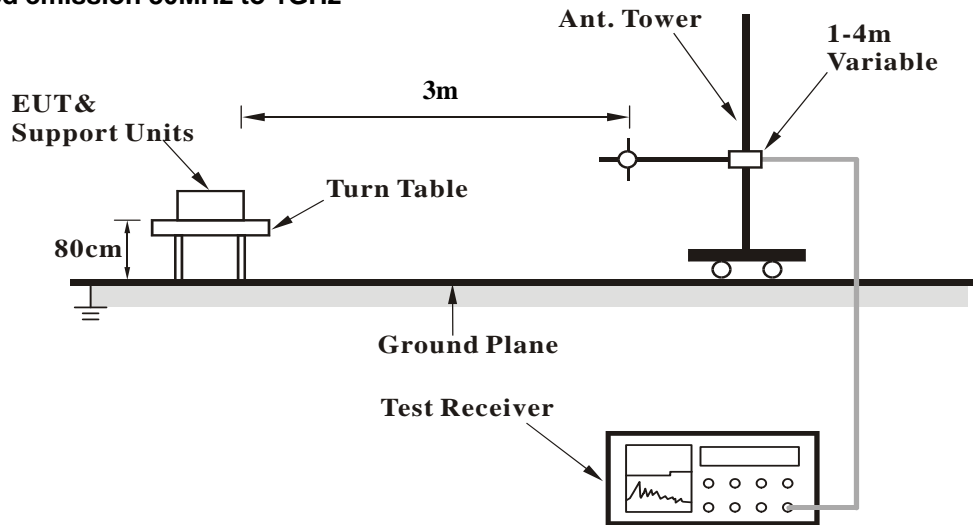

For Radiated emission above 1GHz

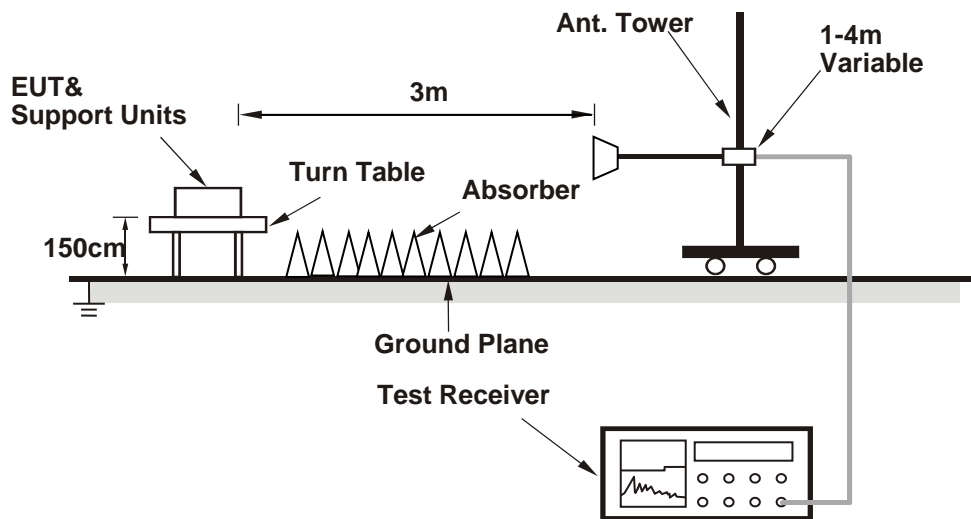

For the actual test configuration, please refer to the attached file (Test Setup Photo).

4.1.6 EUT Operating Conditions

- Placed the EUT on the testing table.
- Prepared notebook to act as communication partner and placed it outside of testing area.
- The communication partner connected with EUT via a RJ45 cable and ran a test program (provided by manufacturer) to enable EUT under transmission condition continuously at specific channel frequency.
- The communication partner sent data to EUT by command "PING".
- The necessary accessories enable the system in full functions.

4.1.7 Test Results

Above 1GHz worst-Case data:

802.11b

CHANNEL	TX Channel 1	DETECTOR FUNCTION	Peak (PK)
FREQUENCY RANGE	1GHz ~ 25GHz		Average (AV)

ANTENNA POLARITY & TEST DISTANCE: HORIZONTAL AT 3 M								
NO.	FREQ. (MHz)	EMISSION LEVEL (dBuV/m)	LIMIT (dBuV/m)	MARGIN (dB)	ANTENNA HEIGHT (m)	TABLE ANGLE (Degree)	RAW VALUE (dBuV)	CORRECTION FACTOR (dB/m)
1	2390.00	65.7 PK	74.0	-8.3	1.93 H	346	32.8	32.9
2	2390.00	52.9 AV	54.0	-1.1	1.93 H	346	20.0	32.9
3	*2412.00	119.3 PK			1.77 H	342	86.4	32.9
4	*2412.00	116.1 AV			1.77 H	342	83.2	32.9
5	4824.00	45.4 PK	74.0	-28.6	1.76 H	251	41.7	3.7
6	4824.00	31.6 AV	54.0	-22.4	1.76 H	251	27.9	3.7
ANTENNA POLARITY & TEST DISTANCE: VERTICAL AT 3 M								
NO.	FREQ. (MHz)	EMISSION LEVEL (dBuV/m)	LIMIT (dBuV/m)	MARGIN (dB)	ANTENNA HEIGHT (m)	TABLE ANGLE (Degree)	RAW VALUE (dBuV)	CORRECTION FACTOR (dB/m)
1	2390.00	63.0 PK	74.0	-11.0	2.95 V	342	30.1	32.9
2	2390.00	50.3 AV	54.0	-3.7	2.95 V	342	17.4	32.9
3	*2412.00	117.4 PK			2.39 V	343	84.5	32.9
4	*2412.00	114.1 AV			2.39 V	343	81.2	32.9
5	4824.00	33.9 PK	74.0	-40.1	1.65 V	231	30.2	3.7
6	4824.00	33.2 AV	54.0	-20.8	1.65 V	231	29.5	3.7

Remarks:

1. Emission Level(dBuV/m) = Raw Value(dBuV) + Correction Factor(dB/m)
2. Correction Factor(dB/m) = Antenna Factor(dB/m) + Cable Factor(dB) – Pre-Amplifier Factor(dB)
3. The other emission levels were very low against the limit.
4. Margin value = Emission Level – Limit value
5. " * ": Fundamental frequency.

CHANNEL	TX Channel 6	DETECTOR FUNCTION	Peak (PK)
FREQUENCY RANGE	1GHz ~ 25GHz		Average (AV)

ANTENNA POLARITY & TEST DISTANCE: HORIZONTAL AT 3 M								
NO.	FREQ. (MHz)	EMISSION LEVEL (dBuV/m)	LIMIT (dBuV/m)	MARGIN (dB)	ANTENNA HEIGHT (m)	TABLE ANGLE (Degree)	RAW VALUE (dBuV)	CORRECTION FACTOR (dB/m)
1	2390.00	59.7 PK	74.0	-14.3	3.34 H	329	26.8	32.9
2	2390.00	48.1 AV	54.0	-5.9	3.34 H	329	15.2	32.9
3	*2437.00	120.6 PK			1.57 H	344	87.7	32.9
4	*2437.00	117.2 AV			1.57 H	344	84.3	32.9
5	2483.50	61.1 PK	74.0	-12.9	2.19 H	341	28.1	33.0
6	2483.50	49.0 AV	54.0	-5.0	2.19 H	341	16.0	33.0
7	4874.00	47.8 PK	74.0	-26.2	1.65 H	172	43.8	4.0
8	4874.00	35.3 AV	54.0	-18.7	1.65 H	172	31.3	4.0
ANTENNA POLARITY & TEST DISTANCE: VERTICAL AT 3 M								
NO.	FREQ. (MHz)	EMISSION LEVEL (dBuV/m)	LIMIT (dBuV/m)	MARGIN (dB)	ANTENNA HEIGHT (m)	TABLE ANGLE (Degree)	RAW VALUE (dBuV)	CORRECTION FACTOR (dB/m)
1	2390.00	60.3 PK	74.0	-13.7	3.19 V	348	27.4	32.9
2	2390.00	48.0 AV	54.0	-6.0	3.19 V	348	15.1	32.9
3	*2437.00	117.5 PK			2.13 V	343	84.6	32.9
4	*2437.00	114.1 AV			2.13 V	343	81.2	32.9
5	2483.50	60.2 PK	74.0	-13.8	1.69 V	348	27.2	33.0
6	2483.50	48.3 AV	54.0	-5.7	1.69 V	348	15.3	33.0
7	4874.00	47.4 PK	74.0	-26.6	1.72 V	186	43.4	4.0
8	4874.00	34.2 AV	54.0	-19.8	1.72 V	186	30.2	4.0

Remarks:

1. Emission Level(dBuV/m) = Raw Value(dBuV) + Correction Factor(dB/m)
2. Correction Factor(dB/m) = Antenna Factor(dB/m) + Cable Factor(dB) – Pre-Amplifier Factor(dB)
3. The other emission levels were very low against the limit.
4. Margin value = Emission Level – Limit value
5. " * ": Fundamental frequency.

CHANNEL	TX Channel 11	DETECTOR FUNCTION	Peak (PK)
FREQUENCY RANGE	1GHz ~ 25GHz		Average (AV)

ANTENNA POLARITY & TEST DISTANCE: HORIZONTAL AT 3 M								
NO.	FREQ. (MHz)	EMISSION LEVEL (dBuV/m)	LIMIT (dBuV/m)	MARGIN (dB)	ANTENNA HEIGHT (m)	TABLE ANGLE (Degree)	RAW VALUE (dBuV)	CORRECTION FACTOR (dB/m)
1	*2462.00	119.9 PK			1.62 H	345	87.0	32.9
2	*2462.00	116.6 AV			1.62 H	345	83.7	32.9
3	2483.50	65.0 PK	74.0	-9.0	1.35 H	348	32.0	33.0
4	2483.50	52.9 AV	54.0	-1.1	1.35 H	348	19.9	33.0
5	4924.00	47.7 PK	74.0	-26.3	1.68 H	175	43.7	4.0
6	4924.00	35.0 AV	54.0	-19.0	1.68 H	175	31.0	4.0

ANTENNA POLARITY & TEST DISTANCE: VERTICAL AT 3 M								
NO.	FREQ. (MHz)	EMISSION LEVEL (dBuV/m)	LIMIT (dBuV/m)	MARGIN (dB)	ANTENNA HEIGHT (m)	TABLE ANGLE (Degree)	RAW VALUE (dBuV)	CORRECTION FACTOR (dB/m)
1	*2462.00	117.4 PK			2.30 V	340	84.5	32.9
2	*2462.00	113.8 AV			2.30 V	340	80.9	32.9
3	2483.50	63.7 PK	74.0	-10.3	2.04 V	343	30.7	33.0
4	2483.50	52.3 AV	54.0	-1.7	2.04 V	343	19.3	33.0
5	4924.00	47.2 PK	74.0	-26.8	1.63 V	172	43.2	4.0
6	4924.00	34.0 AV	54.0	-20.0	1.63 V	172	30.0	4.0

Remarks:

1. Emission Level(dBuV/m) = Raw Value(dBuV) + Correction Factor(dB/m)
2. Correction Factor(dB/m) = Antenna Factor(dB/m) + Cable Factor(dB) – Pre-Amplifier Factor(dB)
3. The other emission levels were very low against the limit.
4. Margin value = Emission Level – Limit value
5. " * ": Fundamental frequency.

802.11g

CHANNEL	TX Channel 1	DETECTOR FUNCTION	Peak (PK)
FREQUENCY RANGE	1GHz ~ 25GHz		Average (AV)

ANTENNA POLARITY & TEST DISTANCE: HORIZONTAL AT 3 M								
NO.	FREQ. (MHz)	EMISSION LEVEL (dBuV/m)	LIMIT (dBuV/m)	MARGIN (dB)	ANTENNA HEIGHT (m)	TABLE ANGLE (Degree)	RAW VALUE (dBuV)	CORRECTION FACTOR (dB/m)
1	2390.00	72.2 PK	74.0	-1.8	1.61 H	348	39.3	32.9
2	2390.00	52.0 AV	54.0	-2.0	1.61 H	348	19.1	32.9
3	*2412.00	117.6 PK			1.80 H	345	84.7	32.9
4	*2412.00	107.1 AV			1.80 H	345	74.2	32.9
5	4824.00	46.0 PK	74.0	-28.0	1.68 H	239	42.3	3.7
6	4824.00	33.2 AV	54.0	-20.8	1.68 H	239	29.5	3.7
ANTENNA POLARITY & TEST DISTANCE: VERTICAL AT 3 M								
NO.	FREQ. (MHz)	EMISSION LEVEL (dBuV/m)	LIMIT (dBuV/m)	MARGIN (dB)	ANTENNA HEIGHT (m)	TABLE ANGLE (Degree)	RAW VALUE (dBuV)	CORRECTION FACTOR (dB/m)
1	2390.00	68.7 PK	74.0	-5.3	1.70 V	349	35.8	32.9
2	2390.00	49.4 AV	54.0	-4.6	1.70 V	349	16.5	32.9
3	*2412.00	111.9 PK			3.43 V	351	79.0	32.9
4	*2412.00	102.7 AV			3.43 V	351	69.8	32.9
5	4824.00	45.6 PK	74.0	-28.4	1.72 V	225	41.9	3.7
6	4824.00	32.7 AV	54.0	-21.3	1.72 V	225	29.0	3.7

Remarks:

1. Emission Level(dBuV/m) = Raw Value(dBuV) + Correction Factor(dB/m)
2. Correction Factor(dB/m) = Antenna Factor(dB/m) + Cable Factor(dB) – Pre-Amplifier Factor(dB)
3. The other emission levels were very low against the limit.
4. Margin value = Emission Level – Limit value
5. " * ": Fundamental frequency.

CHANNEL	TX Channel 6	DETECTOR FUNCTION	Peak (PK)
FREQUENCY RANGE	1GHz ~ 25GHz		Average (AV)

ANTENNA POLARITY & TEST DISTANCE: HORIZONTAL AT 3 M								
NO.	FREQ. (MHz)	EMISSION LEVEL (dBuV/m)	LIMIT (dBuV/m)	MARGIN (dB)	ANTENNA HEIGHT (m)	TABLE ANGLE (Degree)	RAW VALUE (dBuV)	CORRECTION FACTOR (dB/m)
1	2390.00	70.7 PK	74.0	-3.3	2.77 H	338	37.8	32.9
2	2390.00	52.6 AV	54.0	-1.4	2.77 H	338	19.7	32.9
3	*2437.00	124.1 PK			1.94 H	344	91.2	32.9
4	*2437.00	114.5 AV			1.94 H	344	81.6	32.9
5	2483.50	70.6 PK	74.0	-3.4	2.52 H	348	37.6	33.0
6	2483.50	52.9 AV	54.0	-1.1	2.52 H	348	19.9	33.0
7	4874.00	47.3 PK	74.0	-26.7	1.68 H	178	43.3	4.0
8	4874.00	34.1 AV	54.0	-19.9	1.68 H	178	30.1	4.0

ANTENNA POLARITY & TEST DISTANCE: VERTICAL AT 3 M								
NO.	FREQ. (MHz)	EMISSION LEVEL (dBuV/m)	LIMIT (dBuV/m)	MARGIN (dB)	ANTENNA HEIGHT (m)	TABLE ANGLE (Degree)	RAW VALUE (dBuV)	CORRECTION FACTOR (dB/m)
1	2390.00	69.2 PK	74.0	-4.8	2.72 V	346	36.3	32.9
2	2390.00	49.8 AV	54.0	-4.2	2.72 V	346	16.9	32.9
3	*2437.00	119.7 PK			2.33 V	348	86.8	32.9
4	*2437.00	110.6 AV			2.33 V	348	77.7	32.9
5	2483.50	64.6 PK	74.0	-9.4	2.34 V	345	31.6	33.0
6	2483.50	49.6 AV	54.0	-4.4	2.34 V	345	16.6	33.0
7	4874.00	47.2 PK	74.0	-26.8	1.62 V	182	43.2	4.0
8	4874.00	33.7 AV	54.0	-20.3	1.62 V	182	29.7	4.0

Remarks:

1. Emission Level(dBuV/m) = Raw Value(dBuV) + Correction Factor(dB/m)
2. Correction Factor(dB/m) = Antenna Factor(dB/m) + Cable Factor(dB) – Pre-Amplifier Factor(dB)
3. The other emission levels were very low against the limit.
4. Margin value = Emission Level – Limit value
5. " * ": Fundamental frequency.

CHANNEL	TX Channel 11	DETECTOR FUNCTION	Peak (PK)
FREQUENCY RANGE	1GHz ~ 25GHz		Average (AV)

ANTENNA POLARITY & TEST DISTANCE: HORIZONTAL AT 3 M								
NO.	FREQ. (MHz)	EMISSION LEVEL (dBuV/m)	LIMIT (dBuV/m)	MARGIN (dB)	ANTENNA HEIGHT (m)	TABLE ANGLE (Degree)	RAW VALUE (dBuV)	CORRECTION FACTOR (dB/m)
1	*2462.00	116.9 PK			1.81 H	348	84.0	32.9
2	*2462.00	107.2 AV			1.81 H	348	74.3	32.9
3	2483.50	71.7 PK	74.0	-2.3	1.43 H	349	38.7	33.0
4	2483.50	52.9 AV	54.0	-1.1	1.43 H	349	19.9	33.0
5	4924.00	48.0 PK	74.0	-26.0	1.58 H	168	44.0	4.0
6	4924.00	34.3 AV	54.0	-19.7	1.58 H	168	30.3	4.0

ANTENNA POLARITY & TEST DISTANCE: VERTICAL AT 3 M								
NO.	FREQ. (MHz)	EMISSION LEVEL (dBuV/m)	LIMIT (dBuV/m)	MARGIN (dB)	ANTENNA HEIGHT (m)	TABLE ANGLE (Degree)	RAW VALUE (dBuV)	CORRECTION FACTOR (dB/m)
1	*2462.00	112.4 PK			1.85 V	347	79.5	32.9
2	*2462.00	103.0 AV			1.85 V	347	70.1	32.9
3	2483.50	65.4 PK	74.0	-8.6	1.66 V	349	32.4	33.0
4	2483.50	49.6 AV	54.0	-4.4	1.66 V	349	16.6	33.0
5	4924.00	47.2 PK	74.0	-26.8	1.63 V	172	43.2	4.0
6	4924.00	33.8 AV	54.0	-20.2	1.63 V	172	29.8	4.0

Remarks:

1. Emission Level(dBuV/m) = Raw Value(dBuV) + Correction Factor(dB/m)
2. Correction Factor(dB/m) = Antenna Factor(dB/m) + Cable Factor(dB) – Pre-Amplifier Factor(dB)
3. The other emission levels were very low against the limit.
4. Margin value = Emission Level – Limit value
5. " * ": Fundamental frequency.

802.11n (HT20)

CHANNEL	TX Channel 1	DETECTOR FUNCTION	Peak (PK)
FREQUENCY RANGE	1GHz ~ 25GHz		Average (AV)

ANTENNA POLARITY & TEST DISTANCE: HORIZONTAL AT 3 M								
NO.	FREQ. (MHz)	EMISSION LEVEL (dBuV/m)	LIMIT (dBuV/m)	MARGIN (dB)	ANTENNA HEIGHT (m)	TABLE ANGLE (Degree)	RAW VALUE (dBuV)	CORRECTION FACTOR (dB/m)
1	2390.00	72.9 PK	74.0	-1.1	2.08 H	345	40.0	32.9
2	2390.00	52.2 AV	54.0	-1.8	2.08 H	345	19.3	32.9
3	*2412.00	116.2 PK			2.35 H	242	83.3	32.9
4	*2412.00	105.8 AV			2.35 H	242	72.9	32.9
5	4824.00	46.1 PK	74.0	-27.9	1.65 H	187	42.4	3.7
6	4824.00	33.4 AV	54.0	-20.6	1.65 H	187	29.7	3.7
ANTENNA POLARITY & TEST DISTANCE: VERTICAL AT 3 M								
NO.	FREQ. (MHz)	EMISSION LEVEL (dBuV/m)	LIMIT (dBuV/m)	MARGIN (dB)	ANTENNA HEIGHT (m)	TABLE ANGLE (Degree)	RAW VALUE (dBuV)	CORRECTION FACTOR (dB/m)
1	2390.00	65.5 PK	74.0	-8.5	1.92 V	348	32.6	32.9
2	2390.00	49.0 AV	54.0	-5.0	1.92 V	348	16.1	32.9
3	*2412.00	112.8 PK			1.54 V	347	79.9	32.9
4	*2412.00	102.9 AV			1.54 V	347	70.0	32.9
5	4824.00	46.4 PK	74.0	-27.6	1.69 V	180	42.7	3.7
6	4824.00	32.6 AV	54.0	-21.4	1.69 V	180	28.9	3.7

Remarks:

1. Emission Level(dBuV/m) = Raw Value(dBuV) + Correction Factor(dB/m)
2. Correction Factor(dB/m) = Antenna Factor(dB/m) + Cable Factor(dB) – Pre-Amplifier Factor(dB)
3. The other emission levels were very low against the limit.
4. Margin value = Emission Level – Limit value
5. " * ": Fundamental frequency.

CHANNEL	TX Channel 6	DETECTOR FUNCTION	Peak (PK)
FREQUENCY RANGE	1GHz ~ 25GHz		Average (AV)

ANTENNA POLARITY & TEST DISTANCE: HORIZONTAL AT 3 M								
NO.	FREQ. (MHz)	EMISSION LEVEL (dBuV/m)	LIMIT (dBuV/m)	MARGIN (dB)	ANTENNA HEIGHT (m)	TABLE ANGLE (Degree)	RAW VALUE (dBuV)	CORRECTION FACTOR (dB/m)
1	2390.00	72.7 PK	74.0	-1.3	1.69 H	342	39.8	32.9
2	2390.00	51.1 AV	54.0	-2.9	1.69 H	342	18.2	32.9
3	*2437.00	123.0 PK			2.13 H	343	90.1	32.9
4	*2437.00	112.2 AV			2.13 H	343	79.3	32.9
5	2483.50	70.4 PK	74.0	-3.6	2.14 H	352	37.4	33.0
6	2483.50	50.9 AV	54.0	-3.1	2.14 H	352	17.9	33.0
7	4874.00	47.1 PK	74.0	-26.9	1.59 H	164	43.1	4.0
8	4874.00	34.0 AV	54.0	-20.0	1.59 H	164	30.0	4.0

ANTENNA POLARITY & TEST DISTANCE: VERTICAL AT 3 M								
NO.	FREQ. (MHz)	EMISSION LEVEL (dBuV/m)	LIMIT (dBuV/m)	MARGIN (dB)	ANTENNA HEIGHT (m)	TABLE ANGLE (Degree)	RAW VALUE (dBuV)	CORRECTION FACTOR (dB/m)
1	2390.00	66.2 PK	74.0	-7.8	1.42 V	355	33.3	32.9
2	2390.00	49.2 AV	54.0	-4.8	1.42 V	355	16.3	32.9
3	*2437.00	118.4 PK			1.73 V	353	85.5	32.9
4	*2437.00	108.6 AV			1.73 V	353	75.7	32.9
5	2483.50	64.8 PK	74.0	-9.2	1.45 V	345	31.8	33.0
6	2483.50	49.2 AV	54.0	-4.8	1.45 V	345	16.2	33.0
7	4874.00	46.9 PK	74.0	-27.1	1.64 V	170	42.9	4.0
8	4874.00	33.7 AV	54.0	-20.3	1.64 V	170	29.7	4.0

Remarks:

1. Emission Level(dBuV/m) = Raw Value(dBuV) + Correction Factor(dB/m)
2. Correction Factor(dB/m) = Antenna Factor(dB/m) + Cable Factor(dB) – Pre-Amplifier Factor(dB)
3. The other emission levels were very low against the limit.
4. Margin value = Emission Level – Limit value
5. " * ": Fundamental frequency.

CHANNEL	TX Channel 11	DETECTOR FUNCTION	Peak (PK)
FREQUENCY RANGE	1GHz ~ 25GHz		Average (AV)

ANTENNA POLARITY & TEST DISTANCE: HORIZONTAL AT 3 M								
NO.	FREQ. (MHz)	EMISSION LEVEL (dBuV/m)	LIMIT (dBuV/m)	MARGIN (dB)	ANTENNA HEIGHT (m)	TABLE ANGLE (Degree)	RAW VALUE (dBuV)	CORRECTION FACTOR (dB/m)
1	*2462.00	116.1 PK			2.30 H	344	83.2	32.9
2	*2462.00	105.4 AV			2.30 H	344	72.5	32.9
3	2483.50	72.2 PK	74.0	-1.8	2.74 H	351	39.2	33.0
4	2483.50	50.6 AV	54.0	-3.4	2.74 H	351	17.6	33.0
5	4924.00	48.1 PK	74.0	-25.9	1.62 H	173	44.1	4.0
6	4924.00	34.7 AV	54.0	-19.3	1.62 H	173	30.7	4.0

ANTENNA POLARITY & TEST DISTANCE: VERTICAL AT 3 M								
NO.	FREQ. (MHz)	EMISSION LEVEL (dBuV/m)	LIMIT (dBuV/m)	MARGIN (dB)	ANTENNA HEIGHT (m)	TABLE ANGLE (Degree)	RAW VALUE (dBuV)	CORRECTION FACTOR (dB/m)
1	*2462.00	111.4 PK			2.84 V	352	78.5	32.9
2	*2462.00	101.8 AV			2.84 V	352	68.9	32.9
3	2483.50	65.0 PK	74.0	-9.0	2.26 V	346	32.0	33.0
4	2483.50	49.1 AV	54.0	-4.9	2.26 V	346	16.1	33.0
5	4924.00	47.9 PK	74.0	-26.1	1.69 V	180	43.9	4.0
6	4924.00	34.0 AV	54.0	-20.0	1.69 V	180	30.0	4.0

Remarks:

1. Emission Level(dBuV/m) = Raw Value(dBuV) + Correction Factor(dB/m)
2. Correction Factor(dB/m) = Antenna Factor(dB/m) + Cable Factor(dB) – Pre-Amplifier Factor(dB)
3. The other emission levels were very low against the limit.
4. Margin value = Emission Level – Limit value
5. " * ": Fundamental frequency.

802.11n (HT40)

CHANNEL	TX Channel 3	DETECTOR FUNCTION	Peak (PK)
FREQUENCY RANGE	1GHz ~ 25GHz		Average (AV)

ANTENNA POLARITY & TEST DISTANCE: HORIZONTAL AT 3 M

NO.	FREQ. (MHz)	EMISSION LEVEL (dBuV/m)	LIMIT (dBuV/m)	MARGIN (dB)	ANTENNA HEIGHT (m)	TABLE ANGLE (Degree)	RAW VALUE (dBuV)	CORRECTION FACTOR (dB/m)
1	2390.00	65.1 PK	74.0	-8.9	3.30 H	342	32.2	32.9
2	2390.00	52.7 AV	54.0	-1.3	3.30 H	342	19.8	32.9
3	*2422.00	108.2 PK			1.71 H	340	75.4	32.8
4	*2422.00	98.0 AV			1.71 H	340	65.2	32.8
5	4844.00	45.0 PK	74.0	-29.0	1.68 H	178	41.1	3.9
6	4844.00	33.3 AV	54.0	-20.7	1.68 H	178	29.4	3.9

ANTENNA POLARITY & TEST DISTANCE: VERTICAL AT 3 M

NO.	FREQ. (MHz)	EMISSION LEVEL (dBuV/m)	LIMIT (dBuV/m)	MARGIN (dB)	ANTENNA HEIGHT (m)	TABLE ANGLE (Degree)	RAW VALUE (dBuV)	CORRECTION FACTOR (dB/m)
1	2390.00	63.6 PK	74.0	-10.4	2.97 V	346	30.7	32.9
2	2390.00	50.9 AV	54.0	-3.1	2.97 V	346	18.0	32.9
3	*2422.00	106.0 PK			1.49 V	348	73.2	32.8
4	*2422.00	96.2 AV			1.49 V	348	63.4	32.8
5	4844.00	46.5 PK	74.0	-27.5	1.72 V	183	42.6	3.9
6	4844.00	33.2 AV	54.0	-20.8	1.72 V	183	29.3	3.9

Remarks:

1. Emission Level(dBuV/m) = Raw Value(dBuV) + Correction Factor(dB/m)
2. Correction Factor(dB/m) = Antenna Factor(dB/m) + Cable Factor(dB) – Pre-Amplifier Factor(dB)
3. The other emission levels were very low against the limit.
4. Margin value = Emission Level – Limit value
5. " * ": Fundamental frequency.

CHANNEL	TX Channel 6	DETECTOR FUNCTION	Peak (PK)
FREQUENCY RANGE	1GHz ~ 25GHz		Average (AV)

ANTENNA POLARITY & TEST DISTANCE: HORIZONTAL AT 3 M								
NO.	FREQ. (MHz)	EMISSION LEVEL (dBuV/m)	LIMIT (dBuV/m)	MARGIN (dB)	ANTENNA HEIGHT (m)	TABLE ANGLE (Degree)	RAW VALUE (dBuV)	CORRECTION FACTOR (dB/m)
1	2390.00	69.0 PK	74.0	-5.0	3.35 H	345	36.1	32.9
2	2390.00	52.4 AV	54.0	-1.6	3.35 H	345	19.5	32.9
3	*2437.00	111.7 PK			3.50 H	348	78.8	32.9
4	*2437.00	102.1 AV			3.50 H	348	69.2	32.9
5	2483.50	69.2 PK	74.0	-4.8	3.16 H	348	36.2	33.0
6	2483.50	52.6 AV	54.0	-1.4	3.16 H	348	19.6	33.0
7	4874.00	47.8 PK	74.0	-26.2	1.63 H	175	43.8	4.0
8	4874.00	34.2 AV	54.0	-19.8	1.63 H	175	30.2	4.0

ANTENNA POLARITY & TEST DISTANCE: VERTICAL AT 3 M								
NO.	FREQ. (MHz)	EMISSION LEVEL (dBuV/m)	LIMIT (dBuV/m)	MARGIN (dB)	ANTENNA HEIGHT (m)	TABLE ANGLE (Degree)	RAW VALUE (dBuV)	CORRECTION FACTOR (dB/m)
1	2390.00	67.4 PK	74.0	-6.6	2.98 V	350	34.5	32.9
2	2390.00	51.4 AV	54.0	-2.6	2.98 V	350	18.5	32.9
3	*2437.00	108.8 PK			2.91 V	351	75.9	32.9
4	*2437.00	98.7 AV			2.91 V	351	65.8	32.9
5	2483.50	66.1 PK	74.0	-7.9	2.71 V	346	33.1	33.0
6	2483.50	51.0 AV	54.0	-3.0	2.71 V	346	18.0	33.0
7	4874.00	47.6 PK	74.0	-26.4	1.69 V	182	43.6	4.0
8	4874.00	33.7 AV	54.0	-20.3	1.69 V	182	29.7	4.0

Remarks:

1. Emission Level(dBuV/m) = Raw Value(dBuV) + Correction Factor(dB/m)
2. Correction Factor(dB/m) = Antenna Factor(dB/m) + Cable Factor(dB) – Pre-Amplifier Factor(dB)
3. The other emission levels were very low against the limit.
4. Margin value = Emission Level – Limit value
5. " * ": Fundamental frequency.

CHANNEL	TX Channel 9	DETECTOR FUNCTION	Peak (PK)
FREQUENCY RANGE	1GHz ~ 25GHz		Average (AV)

ANTENNA POLARITY & TEST DISTANCE: HORIZONTAL AT 3 M								
NO.	FREQ. (MHz)	EMISSION LEVEL (dBuV/m)	LIMIT (dBuV/m)	MARGIN (dB)	ANTENNA HEIGHT (m)	TABLE ANGLE (Degree)	RAW VALUE (dBuV)	CORRECTION FACTOR (dB/m)
1	*2452.00	110.7 PK			2.02 H	351	77.8	32.9
2	*2452.00	100.4 AV			2.02 H	351	67.5	32.9
3	2483.50	64.5 PK	74.0	-9.5	3.14 H	351	31.5	33.0
4	2483.50	52.9 AV	54.0	-1.1	3.14 H	351	19.9	33.0
5	4904.00	46.9 PK	74.0	-27.1	1.68 H	182	42.9	4.0
6	4904.00	34.4 AV	54.0	-19.6	1.68 H	182	30.4	4.0
ANTENNA POLARITY & TEST DISTANCE: VERTICAL AT 3 M								
NO.	FREQ. (MHz)	EMISSION LEVEL (dBuV/m)	LIMIT (dBuV/m)	MARGIN (dB)	ANTENNA HEIGHT (m)	TABLE ANGLE (Degree)	RAW VALUE (dBuV)	CORRECTION FACTOR (dB/m)
1	*2452.00	105.5 PK			2.96 V	347	72.6	32.9
2	*2452.00	95.7 AV			2.96 V	347	62.8	32.9
3	2483.50	62.8 PK	74.0	-11.2	3.01 V	353	29.8	33.0
4	2483.50	50.5 AV	54.0	-3.5	3.01 V	353	17.5	33.0
5	4904.00	47.6 PK	74.0	-26.4	1.62 V	177	43.6	4.0
6	4904.00	33.9 AV	54.0	-20.1	1.62 V	177	29.9	4.0

Remarks:

1. Emission Level(dBuV/m) = Raw Value(dBuV) + Correction Factor(dB/m)
2. Correction Factor(dB/m) = Antenna Factor(dB/m) + Cable Factor(dB) – Pre-Amplifier Factor(dB)
3. The other emission levels were very low against the limit.
4. Margin value = Emission Level – Limit value
5. " * ": Fundamental frequency.

Below 1GHz worst-case data:

802.11g

CHANNEL	TX Channel 6	DETECTOR FUNCTION	Quasi-Peak (QP)
FREQUENCY RANGE	9kHz ~ 1GHz	TEST MODE	A

ANTENNA POLARITY & TEST DISTANCE: HORIZONTAL AT 3 M								
NO.	FREQ. (MHz)	EMISSION LEVEL (dBuV/m)	LIMIT (dBuV/m)	MARGIN (dB)	ANTENNA HEIGHT (m)	TABLE ANGLE (Degree)	RAW VALUE (dBuV)	CORRECTION FACTOR (dB/m)
1	76.56	27.6 QP	40.0	-12.4	2.00 H	155	41.0	-13.4
2	99.89	31.3 QP	43.5	-12.2	2.00 H	219	44.9	-13.6
3	158.22	31.2 QP	43.5	-12.3	1.51 H	6	40.3	-9.1
4	267.10	28.6 QP	46.0	-17.4	1.00 H	53	37.0	-8.4
5	409.04	34.0 QP	46.0	-12.0	2.00 H	106	39.4	-5.4
6	426.53	34.9 QP	46.0	-11.1	2.00 H	83	39.6	-4.7

Remarks:

1. Emission Level(dBuV/m) = Raw Value(dBuV) + Correction Factor(dB/m)
2. Correction Factor(dB/m) = Antenna Factor(dB/m) + Cable Factor(dB) – Pre-Amplifier Factor(dB)
3. The other emission levels were very low against the limit of frequency range 30MHz~1000MHz.
4. Margin value = Emission Level – Limit value
5. The emission levels were very low against the limit of frequency range 9kHz~30MHz: the amplitude of spurious emissions attenuated more than 20dB below the permissible value to be report.

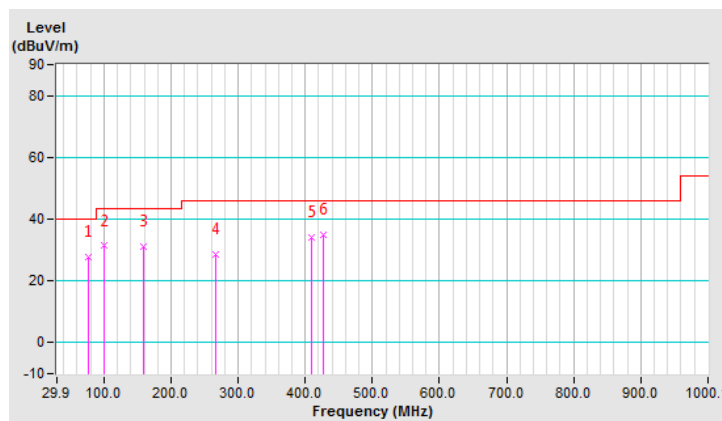

CHANNEL	TX Channel 6	DETECTOR FUNCTION	Quasi-Peak (QP)
FREQUENCY RANGE	9kHz ~ 1GHz	TEST MODE	A

ANTENNA POLARITY & TEST DISTANCE: VERTICAL AT 3 M								
NO.	FREQ. (MHz)	EMISSION LEVEL (dBuV/m)	LIMIT (dBuV/m)	MARGIN (dB)	ANTENNA HEIGHT (m)	TABLE ANGLE (Degree)	RAW VALUE (dBuV)	CORRECTION FACTOR (dB/m)
1	49.34	32.6 QP	40.0	-7.4	1.00 V	42	42.3	-9.7
2	99.89	30.6 QP	43.5	-12.9	1.50 V	77	44.2	-13.6
3	160.17	29.5 QP	43.5	-14.0	1.00 V	296	38.5	-9.0
4	344.87	27.1 QP	46.0	-18.9	1.50 V	47	33.9	-6.8
5	422.65	35.2 QP	46.0	-10.8	1.50 V	247	40.1	-4.9
6	521.81	30.5 QP	46.0	-15.5	1.50 V	230	33.8	-3.3

Remarks:

1. Emission Level(dBuV/m) = Raw Value(dBuV) + Correction Factor(dB/m)
2. Correction Factor(dB/m) = Antenna Factor(dB/m) + Cable Factor(dB) – Pre-Amplifier Factor(dB)
3. The other emission levels were very low against the limit of frequency range 30MHz~1000MHz.
4. Margin value = Emission Level – Limit value
5. The emission levels were very low against the limit of frequency range 9kHz~30MHz: the amplitude of spurious emissions attenuated more than 20dB below the permissible value to be report.

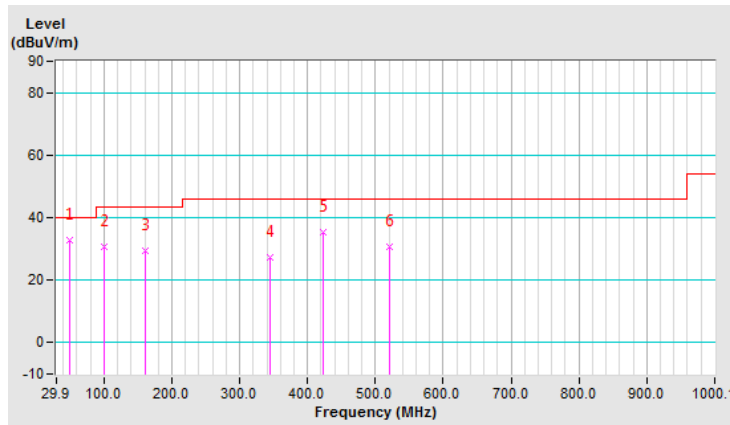

CHANNEL	TX Channel 6	DETECTOR FUNCTION	Quasi-Peak (QP)
FREQUENCY RANGE	9kHz ~ 1GHz	TEST MODE	B

ANTENNA POLARITY & TEST DISTANCE: HORIZONTAL AT 3 M								
NO.	FREQ. (MHz)	EMISSION LEVEL (dBuV/m)	LIMIT (dBuV/m)	MARGIN (dB)	ANTENNA HEIGHT (m)	TABLE ANGLE (Degree)	RAW VALUE (dBuV)	CORRECTION FACTOR (dB/m)
1	90.17	35.0 QP	43.5	-8.5	2.00 H	215	49.6	-14.6
2	132.95	29.4 QP	43.5	-14.1	1.50 H	359	39.6	-10.2
3	222.38	33.4 QP	46.0	-12.6	1.00 H	73	44.0	-10.6
4	333.21	27.5 QP	46.0	-18.5	1.00 H	102	34.2	-6.7
5	420.70	27.4 QP	46.0	-18.6	1.50 H	125	32.3	-4.9
6	500.42	27.4 QP	46.0	-18.6	1.50 H	26	31.0	-3.6

Remarks:

1. Emission Level(dBuV/m) = Raw Value(dBuV) + Correction Factor(dB/m)
2. Correction Factor(dB/m) = Antenna Factor(dB/m) + Cable Factor(dB) – Pre-Amplifier Factor(dB)
3. The other emission levels were very low against the limit of frequency range 30MHz~1000MHz.
4. Margin value = Emission Level – Limit value
5. The emission levels were very low against the limit of frequency range 9kHz~30MHz: the amplitude of spurious emissions attenuated more than 20dB below the permissible value to be report.

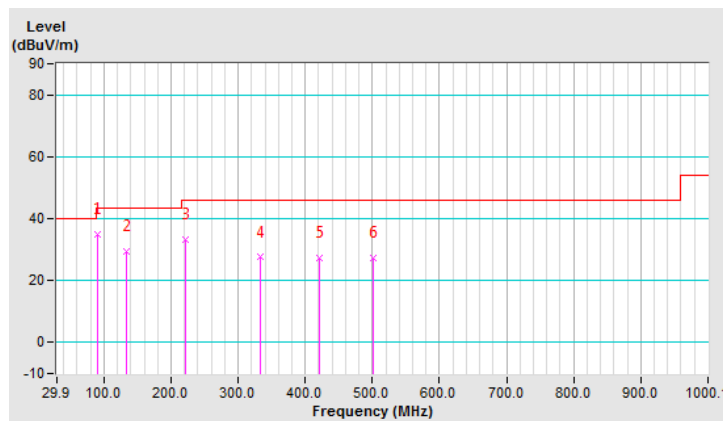

CHANNEL	TX Channel 6	DETECTOR FUNCTION	Quasi-Peak (QP)
FREQUENCY RANGE	9kHz ~ 1GHz	TEST MODE	B

ANTENNA POLARITY & TEST DISTANCE: VERTICAL AT 3 M								
NO.	FREQ. (MHz)	EMISSION LEVEL (dBuV/m)	LIMIT (dBuV/m)	MARGIN (dB)	ANTENNA HEIGHT (m)	TABLE ANGLE (Degree)	RAW VALUE (dBuV)	CORRECTION FACTOR (dB/m)
1	78.51	29.5 QP	40.0	-10.5	1.50 V	70	43.2	-13.7
2	132.95	28.9 QP	43.5	-14.6	1.00 V	296	39.1	-10.2
3	204.89	32.9 QP	43.5	-10.6	1.00 V	163	44.0	-11.1
4	323.49	26.1 QP	46.0	-19.9	2.00 V	197	33.0	-6.9
5	467.36	27.7 QP	46.0	-18.3	1.50 V	195	31.8	-4.1
6	552.91	27.8 QP	46.0	-18.2	1.00 V	282	30.5	-2.7

Remarks:

1. Emission Level(dBuV/m) = Raw Value(dBuV) + Correction Factor(dB/m)
2. Correction Factor(dB/m) = Antenna Factor(dB/m) + Cable Factor(dB) – Pre-Amplifier Factor(dB)
3. The other emission levels were very low against the limit of frequency range 30MHz~1000MHz.
4. Margin value = Emission Level – Limit value
5. The emission levels were very low against the limit of frequency range 9kHz~30MHz: the amplitude of spurious emissions attenuated more than 20dB below the permissible value to be report.

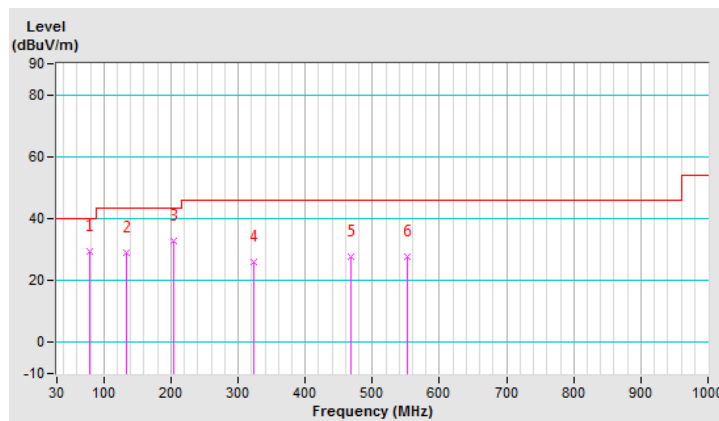

4.2 Conducted Emission Measurement

4.2.1 Limits of Conducted Emission Measurement

Frequency (MHz)	Conducted Limit (dBuV)	
	Quasi-peak	Average
0.15 - 0.5	66 - 56	56 - 46
0.50 - 5.0	56	46
5.0 - 30.0	60	50

- Note:** 1. The lower limit shall apply at the transition frequencies.
 2. The limit decreases in line with the logarithm of the frequency in the range of 0.15 to 0.50MHz.

4.2.2 Test Instruments

Description & Manufacturer	Model No.	Serial No.	Cal. Date	Cal. Due
Test Receiver ROHDE & SCHWARZ	ESCI	100613	Dec. 10, 2018	Dec. 09, 2019
RF signal cable Woken	5D-FB	Cable-cond1-01	Sep. 05, 2018	Sep. 04, 2019
LISN ROHDE & SCHWARZ (EUT)	ENV216	101826	Feb. 21, 2019	Feb. 20, 2020
LISN ROHDE & SCHWARZ (Peripheral)	ESH3-Z5	100311	Aug. 19, 2018	Aug. 18, 2019
Software ADT	BV ADT_Cond_ V7.3.7.4	NA	NA	NA

- Note:** 1. The calibration interval of the above test instruments is 12 months and the calibrations are traceable to NML/ROC and NIST/USA.
 2. The test was performed in HwaYa Shielded Room 1.
 3. The VCCI Site Registration No. is C-12040.

4.2.3 Test Procedures

- The EUT was placed 0.4 meters from the conducting wall of the shielded room with EUT being connected to the power mains through a line impedance stabilization network (LISN). Other support units were connected to the power mains through another LISN. The two LISNs provide 50 ohm/ 50uH of coupling impedance for the measuring instrument.
- Both lines of the power mains connected to the EUT were checked for maximum conducted interference.
- The frequency range from 150kHz to 30MHz was searched. Emission levels under (Limit - 20dB) was not recorded.

Note: The resolution bandwidth and video bandwidth of test receiver is 9kHz for quasi-peak detection (QP) and average detection (AV) at frequency 0.15MHz-30MHz.

4.2.4 Deviation from Test Standard

No deviation.

4.2.5 Test Setup

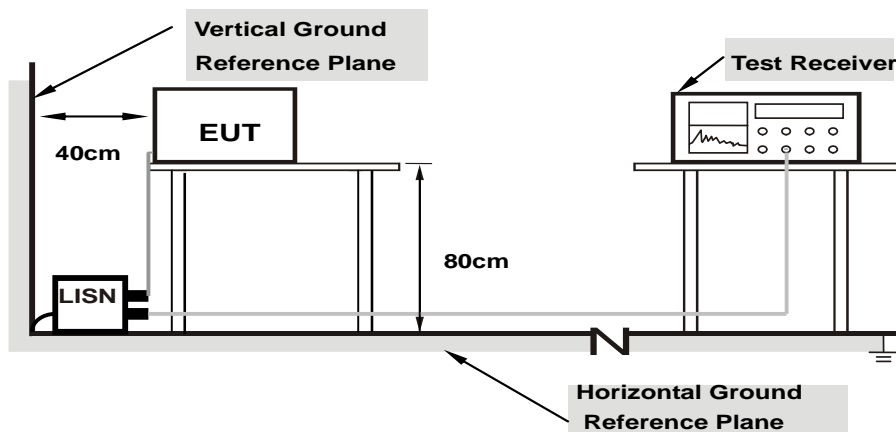

Note: 1.Support units were connected to second LISN.

For the actual test configuration, please refer to the attached file (Test Setup Photo).

4.2.6 EUT Operating Conditions

Same as 4.1.6.

4.2.7 Test Results

Worst-case data: 802.11g

Phase	Line (L)	Detector Function	Quasi-Peak (QP) / Average (AV)
Test Mode	A		

No	Freq. [MHz]	Corr. Factor (dB)	Reading Value		Emission Level		Limit		Margin	
			[dB (uV)]		[dB (uV)]		[dB (uV)]		(dB)	
			Q.P.	AV.	Q.P.	AV.	Q.P.	AV.	Q.P.	AV.
1	0.15000	9.84	44.80	32.24	54.64	42.08	66.00	56.00	-11.36	-13.92
2	0.23216	9.85	32.88	23.51	42.73	33.36	62.37	52.37	-19.64	-19.01
3	0.24775	9.86	30.99	17.17	40.85	27.03	61.83	51.83	-20.98	-24.80
4	0.40415	9.88	30.22	19.99	40.10	29.87	57.77	47.77	-17.67	-17.90
5	4.61522	10.03	15.46	8.84	25.49	18.87	56.00	46.00	-30.51	-27.13
6	5.39722	10.05	16.41	9.35	26.46	19.40	60.00	50.00	-33.54	-30.60

Remarks:

1. Q.P. and AV. are abbreviations of quasi-peak and average individually.
2. The emission levels of other frequencies were very low against the limit.
3. Margin value = Emission level - Limit value
4. Correction factor = Insertion loss + Cable loss
5. Emission Level = Correction Factor + Reading Value.

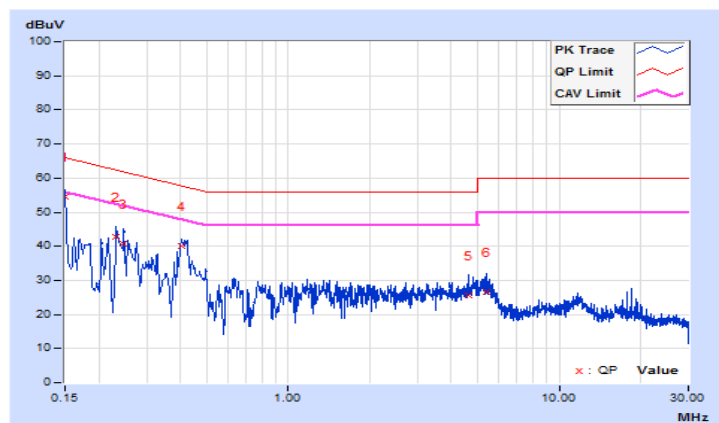

Phase	Neutral (N)	Detector Function	Quasi-Peak (QP) / Average (AV)
Test Mode	A		

No	Freq. [MHz]	Corr. Factor (dB)	Reading Value [dB (uV)]		Emission Level [dB (uV)]		Limit [dB (uV)]		Margin (dB)	
			Q.P.	AV.	Q.P.	AV.	Q.P.	AV.	Q.P.	AV.
			1	0.16139	9.82	40.58	25.30	50.40	35.12	65.39
2	0.18903	9.84	33.95	17.93	43.79	27.77	64.08	54.08	-20.29	-26.31
3	0.41233	9.87	28.32	21.89	38.19	31.76	57.60	47.60	-19.41	-15.84
4	1.74919	9.92	15.94	9.15	25.86	19.07	56.00	46.00	-30.14	-26.93
5	6.64451	10.07	12.17	6.92	22.24	16.99	60.00	50.00	-37.76	-33.01
6	18.55437	10.29	13.45	12.70	23.74	22.99	60.00	50.00	-36.26	-27.01

Remarks:

1. Q.P. and AV. are abbreviations of quasi-peak and average individually.
2. The emission levels of other frequencies were very low against the limit.
3. Margin value = Emission level - Limit value
4. Correction factor = Insertion loss + Cable loss
5. Emission Level = Correction Factor + Reading Value.

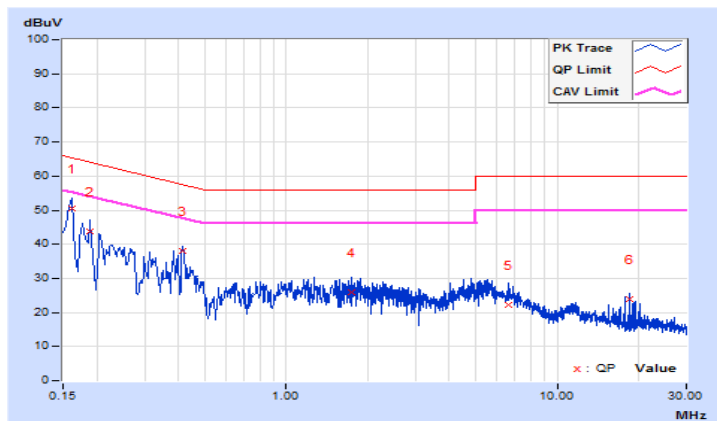

Phase	Line (L)	Detector Function	Quasi-Peak (QP) / Average (AV)
Test Mode	B		

No	Freq. [MHz]	Corr. Factor (dB)	Reading Value [dB (uV)]		Emission Level [dB (uV)]		Limit [dB (uV)]		Margin (dB)	
			Q.P.	AV.	Q.P.	AV.	Q.P.	AV.	Q.P.	AV.
			1	0.15391	9.69	31.23	17.58	40.92	27.27	65.79
2	0.18122	9.68	26.73	13.58	36.41	23.26	64.43	54.43	-28.02	-31.17
3	0.20865	9.68	21.74	9.20	31.42	18.88	63.26	53.26	-31.84	-34.38
4	0.41233	9.68	26.71	18.42	36.39	28.10	57.60	47.60	-21.21	-19.50
5	0.71304	9.67	12.96	5.37	22.63	15.04	56.00	46.00	-33.37	-30.96
6	8.08730	9.83	12.23	3.20	22.06	13.03	60.00	50.00	-37.94	-36.97

Remarks:

1. Q.P. and AV. are abbreviations of quasi-peak and average individually.
2. The emission levels of other frequencies were very low against the limit.
3. Margin value = Emission level - Limit value
4. Correction factor = Insertion loss + Cable loss
5. Emission Level = Correction Factor + Reading Value.

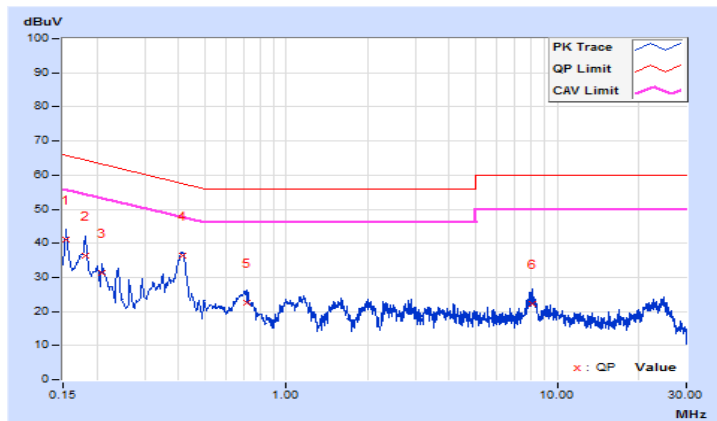

Phase	Neutral (N)	Detector Function	Quasi-Peak (QP) / Average (AV)
Test Mode	B		

No	Freq. [MHz]	Corr. Factor (dB)	Reading Value [dB (uV)]		Emission Level [dB (uV)]		Limit [dB (uV)]		Margin (dB)	
			Q.P.	AV.	Q.P.	AV.	Q.P.	AV.	Q.P.	AV.
			1	0.15000	9.66	31.03	15.93	40.69	25.59	66.00
2	0.17737	9.66	27.28	13.90	36.94	23.56	64.61	54.61	-27.67	-31.05
3	0.23211	9.66	18.77	3.64	28.43	13.30	62.37	52.37	-33.94	-39.07
4	0.41560	9.65	25.17	16.78	34.82	26.43	57.54	47.54	-22.72	-21.11
5	8.13031	9.81	12.91	3.91	22.72	13.72	60.00	50.00	-37.28	-36.28
6	24.93940	10.02	7.31	0.11	17.33	10.13	60.00	50.00	-42.67	-39.87

Remarks:

1. Q.P. and AV. are abbreviations of quasi-peak and average individually.
2. The emission levels of other frequencies were very low against the limit.
3. Margin value = Emission level - Limit value
4. Correction factor = Insertion loss + Cable loss
5. Emission Level = Correction Factor + Reading Value.

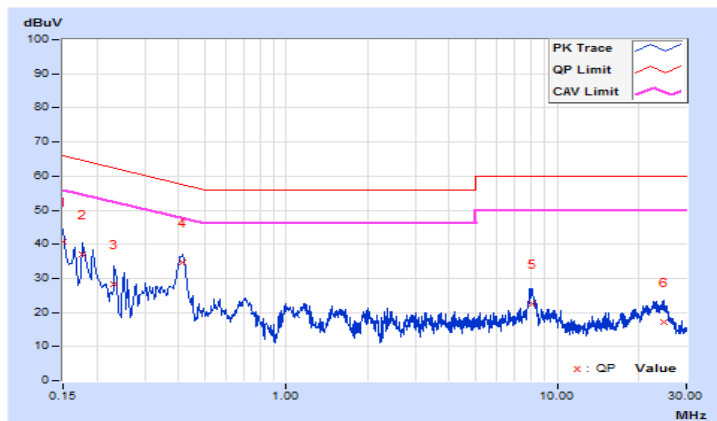

4.3 Conducted Output Power Measurement

4.3.1 Limits of Conducted Output Power Measurement

For systems using digital modulation in the 2400–2483.5 MHz bands: 1 Watt (30dBm)

Per KDB 662911 D01 Multiple Transmitter Output Method of conducted output power measurement on IEEE 802.11 devices,

Array Gain = 0 dB (i.e., no array gain) for $N_{ANT} \leq 4$;

Array Gain = 0 dB (i.e., no array gain) for channel widths ≥ 40 MHz for any N_{ANT} ;

Array Gain = $5 \log(N_{ANT}/N_{SS})$ dB or 3 dB, whichever is less for 20-MHz channel widths with $N_{ANT} \geq 5$.

For power measurements on all other devices: Array Gain = $10 \log(N_{ANT}/N_{SS})$ dB.

4.3.2 Test Setup

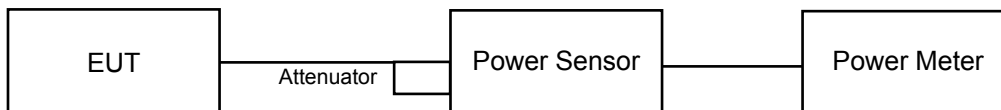

4.3.3 Test Instruments

Refer to section 4.1.2 to get information of above instrument.

4.3.4 Test Procedures

Average power sensor was used to perform output power measurement, trigger and gating function of wide band power meter is enabled to measure max output power of TX on burst. Duty factor is not added to measured value.

4.3.5 Deviation from Test Standard

No deviation.

4.3.6 EUT Operating Conditions

The software provided by client to enable the EUT under transmission condition continuously at lowest, middle and highest channel frequencies individually.

4.3.7 Test Results

CDD Mode

1TX

802.11b

Channel	Frequency (MHz)	Average Power (mW)	Average Power (dBm)	Limit (dBm)	Pass/Fail
1	2412	71.614	18.55	28.00	Pass
6	2437	79.983	19.03	28.00	Pass
11	2462	63.533	18.03	28.00	Pass

*Gain: 8dBi > 6dBi, so the limit shall be reduced to 30-(8-6) = 28dBm.

802.11g

Channel	Frequency (MHz)	Average Power (mW)	Average Power (dBm)	Limit (dBm)	Pass/Fail
1	2412	17.539	12.44	28.00	Pass
6	2437	90.573	19.57	28.00	Pass
11	2462	18.923	12.77	28.00	Pass

*Gain: 8dBi > 6dBi, so the limit shall be reduced to 30-(8-6) = 28dBm.

802.11n (HT20)

Channel	Frequency (MHz)	Average Power (mW)	Average Power (dBm)	Limit (dBm)	Pass/Fail
1	2412	17.100	12.33	28.00	Pass
6	2437	71.614	18.55	28.00	Pass
11	2462	14.655	11.66	28.00	Pass

*Gain: 8dBi > 6dBi, so the limit shall be reduced to 30-(8-6) = 28dBm.

802.11n (HT40)

Channel	Frequency (MHz)	Average Power (mW)	Average Power (dBm)	Limit (dBm)	Pass/Fail
3	2422	11.940	10.77	28.00	Pass
6	2437	20.606	13.14	28.00	Pass
9	2452	11.668	10.67	28.00	Pass

*Gain: 8dBi > 6dBi, so the limit shall be reduced to 30-(8-6) = 28dBm.

2TX

802.11b

Chan.	Freq. (MHz)	Average Power (dBm)		Total Power (mW)	Total Power (dBm)	Limit (dBm)	Pass / Fail
		Chain 0	Chain 1				
1	2412	18.55	18.53	142.899	21.55	28.00	Pass
6	2437	19.03	18.95	158.507	22.00	28.00	Pass
11	2462	18.03	17.95	125.906	21.00	28.00	Pass

*Gain: 8dBi > 6dBi, so the limit shall be reduced to $30-(8-6) = 28$ dBm.

802.11g

Chan.	Freq. (MHz)	Average Power (dBm)		Total Power (mW)	Total Power (dBm)	Limit (dBm)	Pass / Fail
		Chain 0	Chain 1				
1	2412	12.44	13.48	39.823	16.00	28.00	Pass
6	2437	19.57	20.44	201.235	23.04	28.00	Pass
11	2462	12.77	13.55	41.569	16.19	28.00	Pass

*Gain: 8dBi > 6dBi, so the limit shall be reduced to $30-(8-6) = 28$ dBm.

802.11n (HT20)

Chan.	Freq. (MHz)	Average Power (dBm)		Total Power (mW)	Total Power (dBm)	Limit (dBm)	Pass / Fail
		Chain 0	Chain 1				
1	2412	12.33	13.31	38.529	15.86	28.00	Pass
6	2437	18.55	19.15	153.838	21.87	28.00	Pass
11	2462	11.66	12.95	34.379	15.36	28.00	Pass

*Gain: 8dBi > 6dBi, so the limit shall be reduced to $30-(8-6) = 28$ dBm.

802.11n (HT40)

Chan.	Freq. (MHz)	Average Power (dBm)		Total Power (mW)	Total Power (dBm)	Limit (dBm)	Pass / Fail
		Chain 0	Chain 1				
3	2422	10.77	10.85	24.102	13.82	28.00	Pass
6	2437	13.14	13.75	44.320	16.47	28.00	Pass
9	2452	10.67	10.88	23.914	13.79	28.00	Pass

*Gain: 8dBi > 6dBi, so the limit shall be reduced to $30-(8-6) = 28$ dBm.

3TX

802.11b

Chan.	Freq. (MHz)	Average Power (dBm)			Total Power (mW)	Total Power (dBm)	Limit (dBm)	Pass / Fail
		Chain 0	Chain 1	Chain 2				
1	2412	18.55	18.53	18.81	218.932	23.40	28.00	Pass
6	2437	19.03	18.95	19.15	240.731	23.82	28.00	Pass
11	2462	18.03	17.95	18.22	192.280	22.84	28.00	Pass

*Gain: 8dBi > 6dBi, so the limit shall be reduced to 30-(8-6) = 28dBm.

802.11g

Chan.	Freq. (MHz)	Average Power (dBm)			Total Power (mW)	Total Power (dBm)	Limit (dBm)	Pass / Fail
		Chain 0	Chain 1	Chain 2				
1	2412	12.44	13.48	13.85	64.089	18.07	28.00	Pass
6	2437	19.57	20.44	20.66	317.648	25.02	28.00	Pass
11	2462	12.77	13.55	13.63	64.636	18.10	28.00	Pass

*Gain: 8dBi > 6dBi, so the limit shall be reduced to 30-(8-6) = 28dBm.

802.11n (HT20)

Chan.	Freq. (MHz)	Average Power (dBm)			Total Power (mW)	Total Power (dBm)	Limit (dBm)	Pass / Fail
		Chain 0	Chain 1	Chain 2				
1	2412	12.33	13.31	13.33	60.057	17.79	28.00	Pass
6	2437	18.55	19.15	19.53	243.581	23.87	28.00	Pass
11	2462	11.66	12.95	13.14	54.985	17.40	28.00	Pass

*Gain: 8dBi > 6dBi, so the limit shall be reduced to 30-(8-6) = 28dBm.

802.11n (HT40)

Chan.	Freq. (MHz)	Average Power (dBm)			Total Power (mW)	Total Power (dBm)	Limit (dBm)	Pass / Fail
		Chain 0	Chain 1	Chain 2				
3	2422	10.77	10.85	11.63	38.657	15.87	28.00	Pass
6	2437	13.14	13.75	14.14	70.262	18.47	28.00	Pass
9	2452	10.67	10.88	11.63	38.469	15.85	28.00	Pass

*Gain: 8dBi > 6dBi, so the limit shall be reduced to 30-(8-6) = 28dBm.

4TX

802.11b

Chan.	Chan. Freq. (MHz)	Average Power (dBm)				Total Power (mW)	Total Power (dBm)	Limit (dBm)	Pass / Fail
		Chain 0	Chain 1	Chain 2	Chain 3				
1	2412	18.55	18.53	18.81	18.53	290.217	24.63	28.00	Pass
6	2437	19.03	18.95	19.15	19.18	323.525	25.10	28.00	Pass
11	2462	18.03	17.95	18.22	17.83	252.954	24.03	28.00	Pass

* Gain = 8 dBi > 6dBi, so the power limit shall be reduced to 30-(8-6) = 28.00dBm.

802.11g

Chan.	Chan. Freq. (MHz)	Average Power (dBm)				Total Power (mW)	Total Power (dBm)	Limit (dBm)	Pass / Fail
		Chain 0	Chain 1	Chain 2	Chain 3				
1	2412	12.44	13.48	13.85	13.03	84.180	19.25	28.00	Pass
6	2437	19.57	20.44	20.66	19.97	416.960	26.20	28.00	Pass
11	2462	12.77	13.55	13.63	13.11	85.100	19.30	28.00	Pass

* Gain = 8 dBi > 6dBi, so the power limit shall be reduced to 30-(8-6) = 28.00dBm.

802.11n (HT20)

Chan.	Chan. Freq. (MHz)	Average Power (dBm)				Total Power (mW)	Total Power (dBm)	Limit (dBm)	Pass / Fail
		Chain 0	Chain 1	Chain 2	Chain 3				
1	2412	12.33	13.31	13.33	12.95	79.781	19.02	28.00	Pass
6	2437	18.55	19.15	19.53	18.97	322.467	25.08	28.00	Pass
11	2462	11.66	12.95	13.14	12.55	72.974	18.63	28.00	Pass

* Gain = 8 dBi > 6dBi, so the power limit shall be reduced to 30-(8-6) = 28.00dBm.

802.11n (HT40)

Chan.	Chan. Freq. (MHz)	Average Power (dBm)				Total Power (mW)	Total Power (dBm)	Limit (dBm)	Pass / Fail
		Chain 0	Chain 1	Chain 2	Chain 3				
3	2422	10.77	10.85	11.63	10.31	49.397	16.94	28.00	Pass
6	2437	13.14	13.75	14.14	13.44	92.342	19.65	28.00	Pass
9	2452	10.67	10.88	11.63	10.75	50.354	17.02	28.00	Pass

* Gain = 8 dBi > 6dBi, so the power limit shall be reduced to 30-(8-6) = 28.00dBm.

Beamforming Mode

2TX

802.11n (HT20)

Chan.	Freq. (MHz)	Average Power (dBm)		Total Power (mW)	Total Power (dBm)	Limit (dBm)	Pass / Fail
		Chain 0	Chain 1				
1	2412	12.33	13.31	38.529	15.86	24.99	Pass
6	2437	15.31	15.94	73.227	18.65	24.99	Pass
11	2462	11.66	12.95	34.379	15.36	24.99	Pass

* Directional gain = 8 dBi + 10 log(2) = 11.01dBi > 6dBi, so the power limit shall be reduced to 30-(11.01-6) = 24.99dBm.

802.11n (HT40)

Chan.	Freq. (MHz)	Average Power (dBm)		Total Power (mW)	Total Power (dBm)	Limit (dBm)	Pass / Fail
		Chain 0	Chain 1				
3	2422	10.77	10.85	24.102	13.82	24.99	Pass
6	2437	13.14	13.75	44.320	16.47	24.99	Pass
9	2452	10.67	10.88	23.914	13.79	24.99	Pass

* Directional gain = 8 dBi + 10 log(2) = 11.01dBi > 6dBi, so the power limit shall be reduced to 30-(11.01-6) = 24.99dBm.

3TX

802.11n (HT20)

Chan.	Freq. (MHz)	Average Power (dBm)			Total Power (mW)	Total Power (dBm)	Limit (dBm)	Pass / Fail
		Chain 0	Chain 1	Chain 2				
1	2412	12.33	13.31	13.33	60.057	17.79	23.23	Pass
6	2437	15.31	15.94	16.32	116.082	20.65	23.23	Pass
11	2462	11.66	12.95	13.14	54.985	17.40	23.23	Pass

* Directional gain = 8 dBi + 10 log(3) = 12.77dBi > 6dBi, so the power limit shall be reduced to 30-(12.77-6) = 23.23dBm.

802.11n (HT40)

Chan.	Freq. (MHz)	Average Power (dBm)			Total Power (mW)	Total Power (dBm)	Limit (dBm)	Pass / Fail
		Chain 0	Chain 1	Chain 2				
3	2422	10.77	10.85	11.63	38.657	15.87	23.23	Pass
6	2437	13.14	13.75	14.14	70.262	18.47	23.23	Pass
9	2452	10.67	10.88	11.63	38.469	15.85	23.23	Pass

* Directional gain = 8 dBi + 10 log(3) = 12.77dBi > 6dBi, so the power limit shall be reduced to 30-(12.77-6) = 23.23dBm.

4TX

802.11n (HT20)

Chan.	Chan. Freq. (MHz)	Average Power (dBm)				Total Power (mW)	Total Power (dBm)	Limit (dBm)	Pass / Fail
		Chain 0	Chain 1	Chain 2	Chain 3				
1	2412	12.33	13.31	13.33	12.95	79.781	19.02	21.98	Pass
6	2437	15.31	15.94	16.32	15.77	153.839	21.87	21.98	Pass
11	2462	11.66	12.95	13.14	12.55	72.974	18.63	21.98	Pass

* Directional gain = 8 dBi + 10 log(4) = 14.02dBi > 6dBi, so the power limit shall be reduced to 30-(14.02-6) = 21.98dBm.

802.11n (HT40)

Chan.	Chan. Freq. (MHz)	Average Power (dBm)				Total Power (mW)	Total Power (dBm)	Limit (dBm)	Pass / Fail
		Chain 0	Chain 1	Chain 2	Chain 3				
3	2422	10.77	10.85	11.63	10.31	49.397	16.94	21.98	Pass
6	2437	13.14	13.75	14.14	13.44	92.342	19.65	21.98	Pass
9	2452	10.67	10.88	11.63	10.75	50.354	17.02	21.98	Pass

* Directional gain = 8 dBi + 10 log(4) = 14.02dBi > 6dBi, so the power limit shall be reduced to 30-(14.02-6) = 21.98dBm.

4.4 Power Spectral Density Measurement

4.4.1 Limits of Power Spectral Density Measurement

The Maximum of Power Spectral Density Measurement is 8dBm in any 3 kHz band during any time interval of continuous transmission.

4.4.2 Test Setup

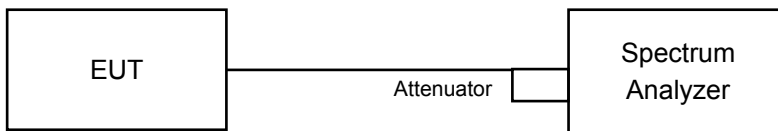

4.4.3 Test Instruments

Refer to section 4.1.2 to get information of above instrument.

4.4.4 Test Procedure

For Average Power (Duty cycle $\geq 98\%$)

- a) Set instrument center frequency to DTS channel center frequency.
- b) Set span to at least 1.5 times the OBW.
- c) Set RBW to: $3 \text{ kHz} \leq \text{RBW} \leq 100 \text{ kHz}$.
- d) Set VBW $\geq 3 \times \text{RBW}$.
- e) Detector = power averaging (RMS) or sample detector (when RMS not available).
- f) Ensure that the number of measurement points in the sweep $\geq 2 \times \text{span}/\text{RBW}$.
- g) Sweep time = auto couple.
- h) Employ trace averaging (RMS) mode over a minimum of 100 traces.
- i) Use the peak marker function to determine the maximum amplitude level.

For Average Power (Duty cycle $< 98\%$)

- a) Measure the duty cycle (x).
- b) Set instrument center frequency to DTS channel center frequency.
- c) Set span to at least 1.5 times the OBW.
- d) Set RBW to: $3 \text{ kHz} \leq \text{RBW} \leq 100 \text{ kHz}$.
- e) Set VBW $\geq 3 \times \text{RBW}$.
- f) Detector = power averaging (RMS) or sample detector (when RMS not available).
- g) Ensure that the number of measurement points in the sweep $\geq 2 \times \text{span}/\text{RBW}$.
- h) Sweep time = auto couple.
- i) Do not use sweep triggering. Allow sweep to "free run".
- j) Employ trace averaging (RMS) mode over a minimum of 100 traces.
- k) Use the peak marker function to determine the maximum amplitude level.
- l) Add $10 \log (1/x)$, where x is the duty cycle measured in step (a), to the measured PSD to compute the average PSD during the actual transmission time.

4.4.5 Deviation from Test Standard

No deviation.

4.4.6 EUT Operating Condition

Same as item 4.3.6.

4.4.7 Test Results

1TX

802.11b

Channel	Freq. (MHz)	PSD without Duty Factor (dBm)	Duty Factor	Total PSD with Duty Factor (dBm)	Limit (dBm)	Pass /Fail
1	2412	-10.51	0.28	-10.23	6.00	Pass
6	2437	-10.27	0.28	-9.99	6.00	Pass
11	2462	-11.13	0.28	-10.85	6.00	Pass

*Gain: 8dBi > 6dBi, so the limit shall be reduced to 8-(8-6) = 6dBm.

802.11g

Channel	Freq. (MHz)	PSD without Duty Factor (dBm)	Duty Factor	Total PSD with Duty Factor (dBm)	Limit (dBm)	Pass /Fail
1	2412	-16.16	0.25	-15.91	6.00	Pass
6	2437	-9.43	0.25	-9.18	6.00	Pass
11	2462	-13.84	0.25	-13.59	6.00	Pass

*Gain: 8dBi > 6dBi, so the limit shall be reduced to 8-(8-6) = 6dBm.

802.11n (HT20)

Channel	Freq. (MHz)	PSD without Duty Factor (dBm)	Duty Factor	Total PSD with Duty Factor (dBm)	Limit (dBm)	Pass /Fail
1	2412	-17.64	0.27	-17.37	6.00	Pass
6	2437	-10.98	0.27	-10.71	6.00	Pass
11	2462	-18.28	0.27	-18.01	6.00	Pass

*Gain: 8dBi > 6dBi, so the limit shall be reduced to 8-(8-6) = 6dBm.

802.11n (HT40)

Channel	Freq. (MHz)	PSD without Duty Factor (dBm)	Duty Factor	Total PSD with Duty Factor (dBm)	Limit (dBm)	Pass /Fail
3	2422	-24.13	0.48	-23.65	6.00	Pass
6	2437	-21.19	0.48	-20.71	6.00	Pass
9	2452	-24.43	0.48	-23.95	6.00	Pass

*Gain: 8dBi > 6dBi, so the limit shall be reduced to 8-(8-6) = 6dBm.

Spectrum Plot of Worst Value

802.11b

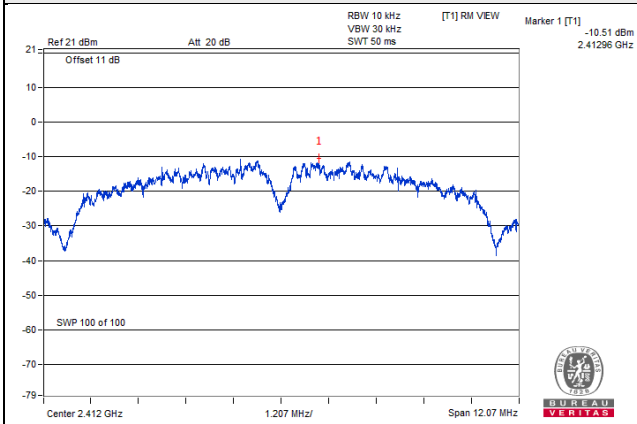

802.11g

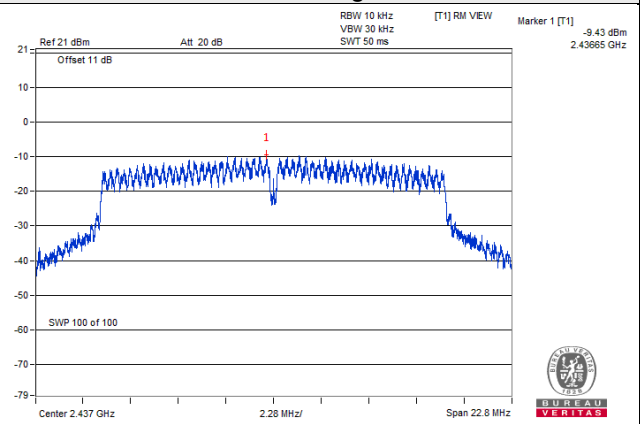

802.11n (HT20)

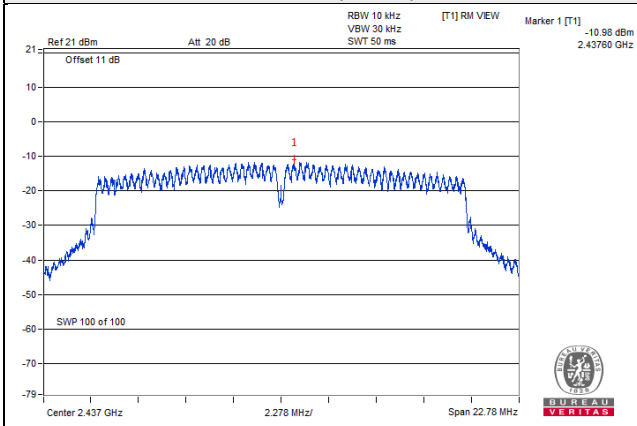

802.11n (HT40)

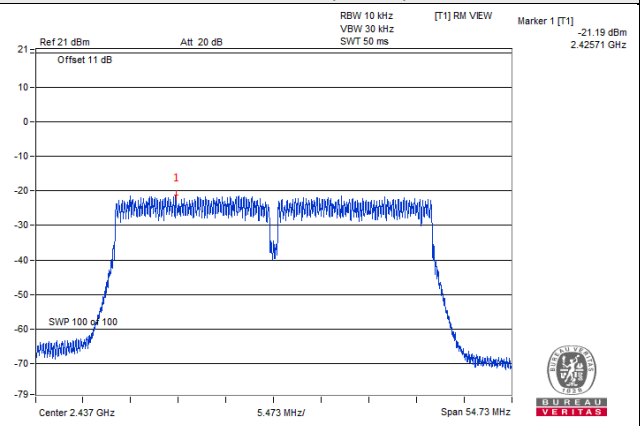

2TX

802.11b

TX chain	Chan.	Freq. (MHz)	PSD (dBm/10kHz)	10 log (N=2) dB	Duty Factor	Total PSD with Duty Factor (dBm/10kHz)	Limit (dBm/10kHz)	Pass / Fail
0	1	2412	-10.51	3.01	0.28	-7.22	2.99	Pass
	6	2437	-10.27	3.01	0.28	-6.98	2.99	Pass
	11	2462	-11.13	3.01	0.28	-7.84	2.99	Pass
1	1	2412	-11.00	3.01	0.28	-7.71	2.99	Pass
	6	2437	-10.51	3.01	0.28	-7.22	2.99	Pass
	11	2462	-10.94	3.01	0.28	-7.65	2.99	Pass

Note:

- Method E) 2) c) of power density measurement of KDB 662911 is using for calculating total power density.
- Directional gain = 8 dBi + 10 log(2) = 11.01dBi > 6dBi, so the power density limit shall be reduced to 8-(11.01-6) = 2.99dBm.
- Refer to section 3.3 for duty cycle spectrum plot.

802.11g

TX chain	Chan.	Freq. (MHz)	PSD (dBm/10kHz)	10 log (N=2) dB	Duty Factor	Total PSD with Duty Factor (dBm/10kHz)	Limit (dBm/10kHz)	Pass / Fail
0	1	2412	-16.16	3.01	0.25	-12.90	2.99	Pass
	6	2437	-9.43	3.01	0.25	-6.17	2.99	Pass
	11	2462	-13.84	3.01	0.25	-10.58	2.99	Pass
1	1	2412	-16.25	3.01	0.25	-12.99	2.99	Pass
	6	2437	-8.93	3.01	0.25	-5.67	2.99	Pass
	11	2462	-16.81	3.01	0.25	-13.55	2.99	Pass

Note:

- Method E) 2) c) of power density measurement of KDB 662911 is using for calculating total power density.
- Directional gain = 8 dBi + 10 log(2) = 11.01dBi > 6dBi, so the power density limit shall be reduced to 8-(11.01-6) = 2.99dBm.
- Refer to section 3.3 for duty cycle spectrum plot.

802.11n (HT20)

TX chain	Chan.	Freq. (MHz)	PSD (dBm/10kHz)	10 log (N=2) dB	Duty Factor	Total PSD with Duty Factor (dBm/10kHz)	Limit (dBm/10kHz)	Pass / Fail
0	1	2412	-17.64	3.01	0.27	-14.36	2.99	Pass
	6	2437	-10.98	3.01	0.27	-7.70	2.99	Pass
	11	2462	-18.28	3.01	0.27	-15.00	2.99	Pass
1	1	2412	-17.69	3.01	0.27	-14.41	2.99	Pass
	6	2437	-11.85	3.01	0.27	-8.57	2.99	Pass
	11	2462	-18.27	3.01	0.27	-14.99	2.99	Pass

Note:

- Method E) 2) c) of power density measurement of KDB 662911 is using for calculating total power density.
- Directional gain = 8 dBi + 10 log(2) = 11.01dBi > 6dBi, so the power density limit shall be reduced to 8-(11.01-6) = 2.99dBm.
- Refer to section 3.3 for duty cycle spectrum plot.

802.11n (HT40)

TX chain	Chan.	Freq. (MHz)	PSD (dBm/10kHz)	10 log (N=2) dB	Duty Factor	Total PSD with Duty Factor (dBm/10kHz)	Limit (dBm/10kHz)	Pass / Fail
0	3	2422	-24.13	3.01	0.48	-20.64	2.99	Pass
	6	2437	-21.19	3.01	0.48	-17.70	2.99	Pass
	9	2452	-24.43	3.01	0.48	-20.94	2.99	Pass
1	3	2422	-23.38	3.01	0.48	-19.89	2.99	Pass
	6	2437	-21.10	3.01	0.48	-17.61	2.99	Pass
	9	2452	-23.82	3.01	0.48	-20.33	2.99	Pass

Note:

- Method E) 2) c) of power density measurement of KDB 662911 is using for calculating total power density.
- Directional gain = 8 dBi + 10 log(2) = 11.01dBi > 6dBi, so the power density limit shall be reduced to 8-(11.01-6) = 2.99dBm.
- Refer to section 3.3 for duty cycle spectrum plot.

Spectrum Plot of Worst Value

802.11b

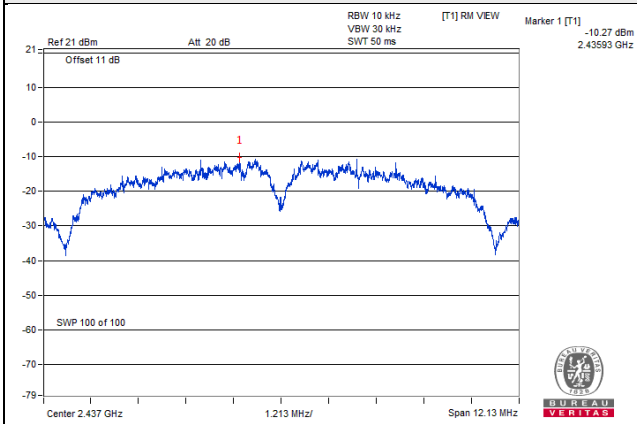

802.11g

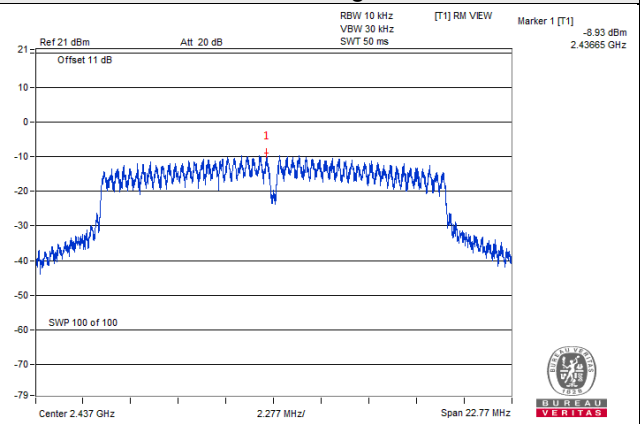

802.11n (HT20)

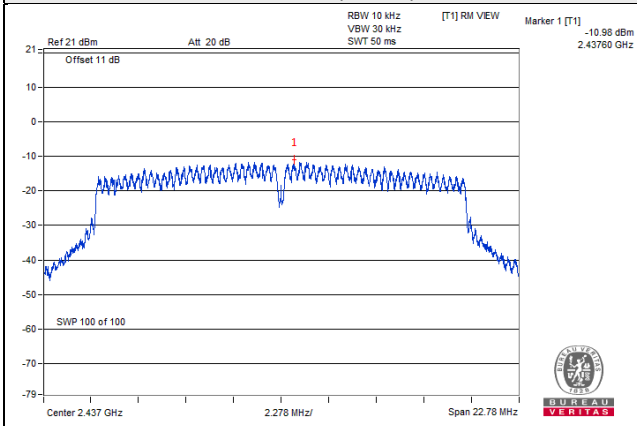

802.11n (HT40)

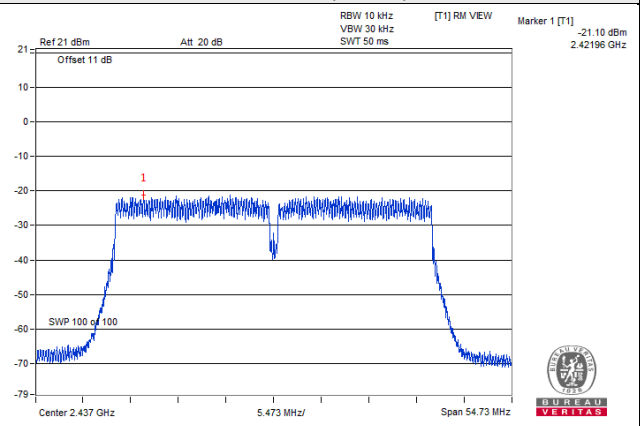

3TX

802.11b

TX chain	Chan.	Freq. (MHz)	PSD (dBm/10kHz)	10 log (N=3) dB	Duty Factor	Total PSD with Duty Factor (dBm/10kHz)	Limit (dBm/10kHz)	Pass / Fail
0	1	2412	-10.51	4.77	0.28	-5.46	1.23	Pass
	6	2437	-10.27	4.77	0.28	-5.22	1.23	Pass
	11	2462	-11.13	4.77	0.28	-6.08	1.23	Pass
1	1	2412	-11.00	4.77	0.28	-5.95	1.23	Pass
	6	2437	-10.51	4.77	0.28	-5.46	1.23	Pass
	11	2462	-10.94	4.77	0.28	-5.89	1.23	Pass
2	1	2412	-10.45	4.77	0.28	-5.40	1.23	Pass
	6	2437	-10.18	4.77	0.28	-5.13	1.23	Pass
	11	2462	-11.48	4.77	0.28	-6.43	1.23	Pass

Note:

- Method E) 2) c) of power density measurement of KDB 662911 is using for calculating total power density.
- Directional gain = 8 dBi + 10 log(3) = 12.77dBi > 6dBi, so the power density limit shall be reduced to 8-(12.77-6) = 1.23dBm.
- Refer to section 3.3 for duty cycle spectrum plot.

802.11g

TX chain	Chan.	Freq. (MHz)	PSD (dBm/10kHz)	10 log (N=3) dB	Duty Factor	Total PSD with Duty Factor (dBm/10kHz)	Limit (dBm/10kHz)	Pass / Fail
0	1	2412	-16.16	4.77	0.25	-11.14	1.23	Pass
	6	2437	-9.43	4.77	0.25	-4.41	1.23	Pass
	11	2462	-13.84	4.77	0.25	-8.82	1.23	Pass
1	1	2412	-16.25	4.77	0.25	-11.23	1.23	Pass
	6	2437	-8.93	4.77	0.25	-3.91	1.23	Pass
	11	2462	-16.81	4.77	0.25	-11.79	1.23	Pass
2	1	2412	-16.94	4.77	0.25	-11.92	1.23	Pass
	6	2437	-9.97	4.77	0.25	-4.95	1.23	Pass
	11	2462	-16.80	4.77	0.25	-11.78	1.23	Pass

Note:

- Method E) 2) c) of power density measurement of KDB 662911 is using for calculating total power density.
- Directional gain = 8 dBi + 10 log(3) = 12.77dBi > 6dBi, so the power density limit shall be reduced to 8-(12.77-6) = 1.23dBm.
- Refer to section 3.3 for duty cycle spectrum plot.

802.11n (HT20)

TX chain	Chan.	Freq. (MHz)	PSD (dBm/10kHz)	10 log (N=3) dB	Duty Factor	Total PSD with Duty Factor (dBm/10kHz)	Limit (dBm/10kHz)	Pass / Fail
0	1	2412	-17.64	4.77	0.27	-12.60	1.23	Pass
	6	2437	-10.98	4.77	0.27	-5.94	1.23	Pass
	11	2462	-18.28	4.77	0.27	-13.24	1.23	Pass
1	1	2412	-17.69	4.77	0.27	-12.65	1.23	Pass
	6	2437	-11.85	4.77	0.27	-6.81	1.23	Pass
	11	2462	-18.27	4.77	0.27	-13.23	1.23	Pass
2	1	2412	-18.59	4.77	0.27	-13.55	1.23	Pass
	6	2437	-12.47	4.77	0.27	-7.43	1.23	Pass
	11	2462	-19.43	4.77	0.27	-14.39	1.23	Pass

Note:

- Method E) 2) c) of power density measurement of KDB 662911 is using for calculating total power density.
- Directional gain = 8 dBi + 10 log(3) = 12.77dBi > 6dBi, so the power density limit shall be reduced to $8-(12.77-6) = 1.23\text{dBm}$.
- Refer to section 3.3 for duty cycle spectrum plot.

802.11n (HT40)

TX chain	Chan.	Freq. (MHz)	PSD (dBm/10kHz)	10 log (N=3) dB	Duty Factor	Total PSD with Duty Factor (dBm/10kHz)	Limit (dBm/10kHz)	Pass / Fail
0	3	2422	-24.13	4.77	0.48	-18.88	1.23	Pass
	6	2437	-21.19	4.77	0.48	-15.94	1.23	Pass
	9	2452	-24.43	4.77	0.48	-19.18	1.23	Pass
1	3	2422	-23.38	4.77	0.48	-18.13	1.23	Pass
	6	2437	-21.10	4.77	0.48	-15.85	1.23	Pass
	9	2452	-23.82	4.77	0.48	-18.57	1.23	Pass
2	3	2422	-24.37	4.77	0.48	-19.12	1.23	Pass
	6	2437	-21.46	4.77	0.48	-16.21	1.23	Pass
	9	2452	-24.24	4.77	0.48	-18.99	1.23	Pass

Note:

- Method E) 2) c) of power density measurement of KDB 662911 is using for calculating total power density.
- Directional gain = 8 dBi + 10 log(3) = 12.77dBi > 6dBi, so the power density limit shall be reduced to $8-(12.77-6) = 1.23\text{dBm}$.
- Refer to section 3.3 for duty cycle spectrum plot.

Spectrum Plot of Worst Value

802.11b

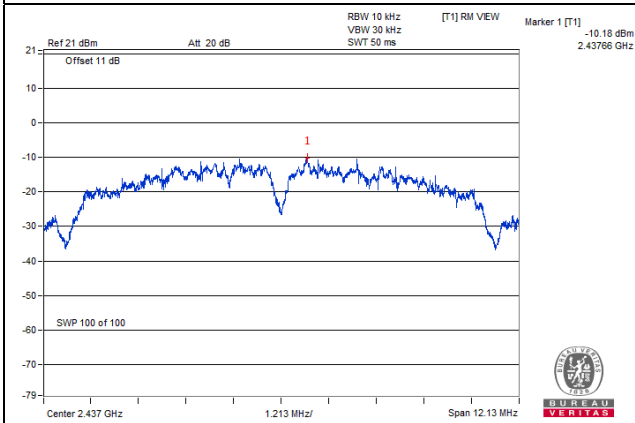

802.11g

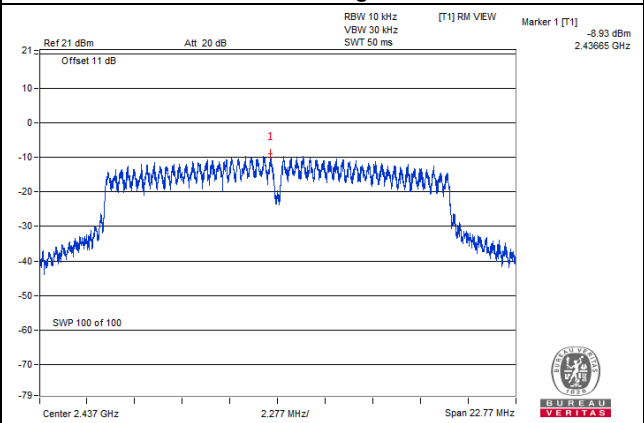

802.11n (HT20)

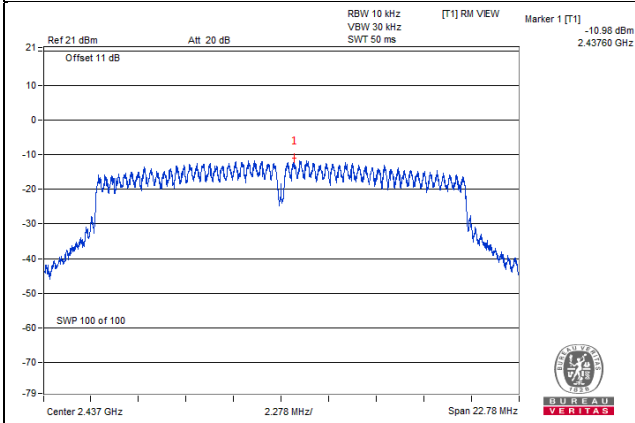

802.11n (HT40)

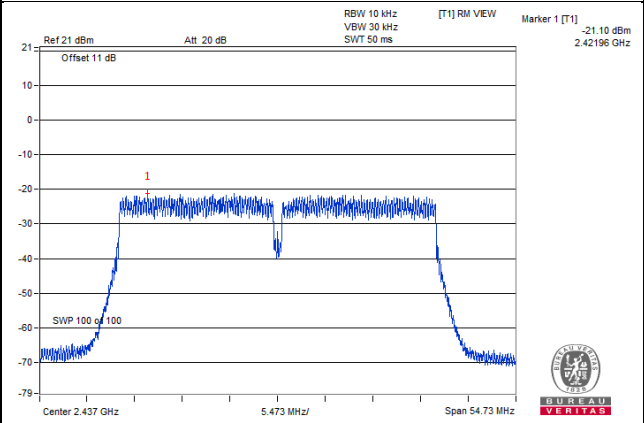

4TX

802.11b

TX chain	Channel	Freq. (MHz)	PSD w/o Duty Factor (dBm/10kHz)	10 log (N=4) dB	Duty Factor (dB)	Total PSD With Duty Factor (dBm/10kHz)	Limit (dBm/3kHz)	Pass / Fail
0	1	2412	-10.51	6.02	0.28	-4.21	-0.02	Pass
	6	2437	-10.27	6.02	0.28	-3.97	-0.02	Pass
	11	2462	-11.13	6.02	0.28	-4.83	-0.02	Pass
1	1	2412	-11.00	6.02	0.28	-4.70	-0.02	Pass
	6	2437	-10.51	6.02	0.28	-4.21	-0.02	Pass
	11	2462	-10.94	6.02	0.28	-4.64	-0.02	Pass
2	1	2412	-10.45	6.02	0.28	-4.15	-0.02	Pass
	6	2437	-10.18	6.02	0.28	-3.88	-0.02	Pass
	11	2462	-11.48	6.02	0.28	-5.18	-0.02	Pass
3	1	2412	-10.93	6.02	0.28	-4.63	-0.02	Pass
	6	2437	-10.97	6.02	0.28	-4.67	-0.02	Pass
	11	2462	-11.36	6.02	0.28	-5.06	-0.02	Pass

Note:

- Method E) 2) c) of power density measurement of KDB 662911 is using for calculating total power density.
- Directional gain = 8 dBi + 10 log(4) = 14.02dBi > 6dBi, so the power density limit shall be reduced to 8-(14.02-6) = -0.02dBm.
- Refer to section 3.3 for duty cycle spectrum plot.

802.11g

TX chain	Channel	Freq. (MHz)	PSD w/o Duty Factor (dBm/10kHz)	10 log (N=4) dB	Duty Factor (dB)	Total PSD With Duty Factor (dBm/10kHz)	Limit (dBm/3kHz)	Pass / Fail
0	1	2412	-16.16	6.02	0.25	-9.89	-0.02	Pass
	6	2437	-9.43	6.02	0.25	-3.16	-0.02	Pass
	11	2462	-13.84	6.02	0.25	-7.57	-0.02	Pass
1	1	2412	-16.25	6.02	0.25	-9.98	-0.02	Pass
	6	2437	-8.93	6.02	0.25	-2.66	-0.02	Pass
	11	2462	-16.81	6.02	0.25	-10.54	-0.02	Pass
2	1	2412	-16.94	6.02	0.25	-10.67	-0.02	Pass
	6	2437	-9.97	6.02	0.25	-3.70	-0.02	Pass
	11	2462	-16.80	6.02	0.25	-10.53	-0.02	Pass
3	1	2412	-16.31	6.02	0.25	-10.04	-0.02	Pass
	6	2437	-9.90	6.02	0.25	-3.63	-0.02	Pass
	11	2462	-10.39	6.02	0.25	-4.12	-0.02	Pass

Note:

- Method E) 2) c) of power density measurement of KDB 662911 is using for calculating total power density.
- Directional gain = 8 dBi + 10 log(4) = 14.02dBi > 6dBi, so the power density limit shall be reduced to 8-(14.02-6) = -0.02dBm.
- Refer to section 3.3 for duty cycle spectrum plot.

802.11n (HT20)

TX chain	Channel	Freq. (MHz)	PSD w/o Duty Factor (dBm/10kHz)	10 log (N=4) dB	Duty Factor (dB)	Total PSD With Duty Factor (dBm/10kHz)	Limit (dBm/3kHz)	Pass / Fail
0	1	2412	-17.64	6.02	0.27	-11.35	-0.02	Pass
	6	2437	-10.98	6.02	0.27	-4.69	-0.02	Pass
	11	2462	-18.28	6.02	0.27	-11.99	-0.02	Pass
1	1	2412	-17.69	6.02	0.27	-11.40	-0.02	Pass
	6	2437	-11.85	6.02	0.27	-5.56	-0.02	Pass
	11	2462	-18.27	6.02	0.27	-11.98	-0.02	Pass
2	1	2412	-18.59	6.02	0.27	-12.30	-0.02	Pass
	6	2437	-12.47	6.02	0.27	-6.18	-0.02	Pass
	11	2462	-19.43	6.02	0.27	-13.14	-0.02	Pass
3	1	2412	-17.91	6.02	0.27	-11.62	-0.02	Pass
	6	2437	-12.00	6.02	0.27	-5.71	-0.02	Pass
	11	2462	-18.14	6.02	0.27	-11.85	-0.02	Pass

Note:

1. Method E) 2) c) of power density measurement of KDB 662911 is using for calculating total power density.
2. Directional gain = 8 dBi + 10 log(4) = 14.02dBi > 6dBi, so the power density limit shall be reduced to 8-(14.02-6) = -0.02dBm.
3. Refer to section 3.3 for duty cycle spectrum plot.

802.11n (HT40)

TX chain	Channel	Freq. (MHz)	PSD w/o Duty Factor (dBm/10kHz)	10 log (N=4) dB	Duty Factor (dB)	Total PSD With Duty Factor (dBm/10kHz)	Limit (dBm/3kHz)	Pass / Fail
0	3	2422	-24.13	6.02	0.48	-17.63	-0.02	Pass
	6	2437	-21.19	6.02	0.48	-14.69	-0.02	Pass
	9	2452	-24.43	6.02	0.48	-17.93	-0.02	Pass
1	3	2422	-23.38	6.02	0.48	-16.88	-0.02	Pass
	6	2437	-21.10	6.02	0.48	-14.60	-0.02	Pass
	9	2452	-23.82	6.02	0.48	-17.32	-0.02	Pass
2	3	2422	-24.37	6.02	0.48	-17.87	-0.02	Pass
	6	2437	-21.46	6.02	0.48	-14.96	-0.02	Pass
	9	2452	-24.24	6.02	0.48	-17.74	-0.02	Pass
3	3	2422	-24.36	6.02	0.48	-17.86	-0.02	Pass
	6	2437	-21.15	6.02	0.48	-14.65	-0.02	Pass
	9	2452	-23.49	6.02	0.48	-16.99	-0.02	Pass

Note:

1. Method E) 2) c) of power density measurement of KDB 662911 is using for calculating total power density.
2. Directional gain = 8 dBi + 10 log(4) = 14.02dBi > 6dBi, so the power density limit shall be reduced to 8-(14.02-6) = -0.02dBm.
3. Refer to section 3.3 for duty cycle spectrum plot.

Spectrum Plot of Worst Value

802.11b

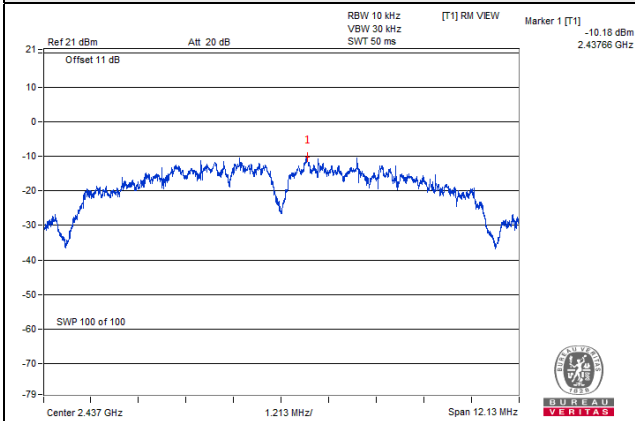

802.11g

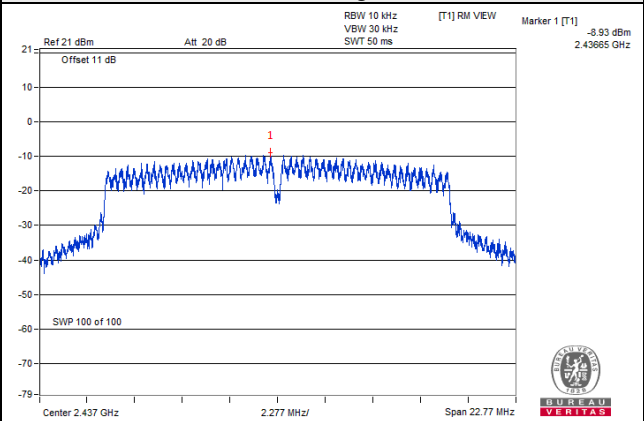

802.11n (HT20)

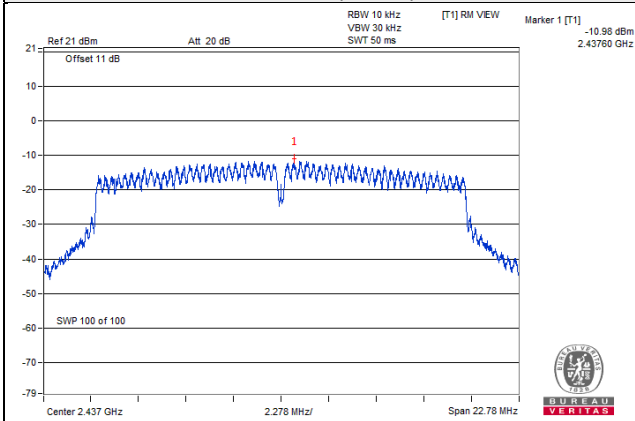

802.11n (HT40)

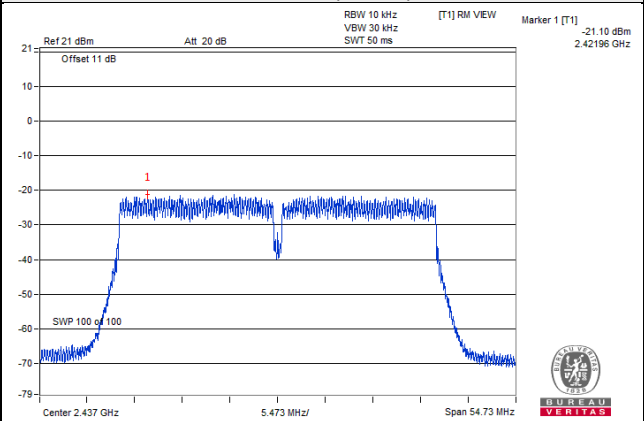

5 Pictures of Test Arrangements

Please refer to the attached file (Test Setup Photo).

Appendix – Information of the Testing Laboratories

We, Bureau Veritas Consumer Products Services (H.K.) Ltd., Taoyuan Branch, were founded in 1988 to provide our best service in EMC, Radio, Telecom and Safety consultation. Our laboratories are FCC recognized accredited test firms and accredited and approved according to ISO/IEC 17025.

If you have any comments, please feel free to contact us at the following:

Lin Kou EMC/RF Lab

Tel: 886-2-26052180

Fax: 886-2-26051924

Hsin Chu EMC/RF/Telecom Lab

Tel: 886-3-6668565

Fax: 886-3-6668323

Hwa Ya EMC/RF/Safety Lab

Tel: 886-3-3183232

Fax: 886-3-3270892

Email: service.adt@tw.bureauveritas.com

Web Site: www.bureauveritas-adt.com

The address and road map of all our labs can be found in our web site also.

--- END ---