

MONSTER SMART ILLUMINESSENCE

STUDIO+ SMART RING LAMP 5PC LIGHTING KIT



QUICK START GUIDE
MLB7-1068-RGB
v1.0 0621

GETTING STARTED

Thank you for choosing the Studio+ Smart Ring Lamp 5pc Lighting Kit by Monster Smart Illuminescence. This quick start guide will help you with setup and installation of your device.

WHAT'S IN THE BOX

- 10" Studio+ Ring Light
- Table Stand with attachment screw
- Wall Mount
- 3M Adhesive
- Extendable Tripod Stand
- Flexible Phone Mount
- Quick Start Guide

WHAT DO YOU NEED?

- Cellphone or tablet with
Android™ 6.0 Marshmallow or higher / iOS 10 or higher
- Wi-Fi router with an internet connection
- Wi-Fi 2.4GHz 802.11n

Before setup, make sure your phone is connected to the **2.4GHz Wi-Fi network** that your Studio+ will be placed on. For easier pairing, turn on location and Bluetooth to quickly find nearby devices.

TIP: Do you know your Wi-Fi network name and password? Write it down now if it's hard to remember.

ANYTHING ELSE?

Your Studio+ can be powered by any 5V 1A USB power source (not included)

TIP: Save these instructions for future reference.

SETUP COMPLETE SETUP BEFORE INSTALLATION

STEP 1

Remove your Studio+ and all components from the box.



STEP 2

Download the **MONSTER SMART** app from the App Store (for iPhone) or Google Play Store (for Android phones).



2

STEP 3

Make sure your phone or tablet is successfully connected to the **2.4GHz Wi-Fi network** that your Studio+ will be placed on and **ensure that your Bluetooth is enabled**.

Open the **MONSTER SMART** app and create an account by following the on-screen instructions.

STEP 4

It is recommended to first pair your Studio+ in a location close to your router **BEFORE** installation.

Connect the USB plug to a powered 5V 1A USB adapter (not included). Press the power button twice to turn on the light.



Press and hold the power button for 5-6 seconds to enter pairing mode or change between pairing modes. The Studio+ will begin blinking when it has entered pairing mode and is ready to pair.

Pairing Modes:

EZ MODE - RAPIDLY BLINKING LED (default) EZ Mode is the default mode for quick and easy pairing setup.
AP MODE - SLOWLY BLINKING LED Access Point Mode is a secondary setup that can help connect to mixed networks. If you have trouble pairing, see troubleshooting on page 7.

! Monster Smart devices only work on a 2.4GHz Wi-Fi network. Many newer home Wi-Fi networks are mixed networks that are set to 5GHz by default (ex: AT&T, Verizon) and you may need to use AP pairing mode to connect. If you still have difficulty, contact your Internet Service Provider for assistance with 2.4GHz network setup.

NOTE: At any time during pairing mode you can disconnect the power and then reconnect it to cancel pairing and operate the product without Wi-Fi using the controller. Advanced features will not be available. Note: Clock may not be accurate time.

3

STEP 5

Confirm that the device is in pairing mode, LED is **RAPIDLY** blinking.

In the **MONSTER SMART** app, select the "+" in the upper right corner of the home screen to add a new device.

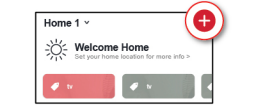

The app will detect the nearby Wi-Fi+BLE enabled device and ask if you would like to add it, click "Go to add". Ensure that the device is checked and then click the "+" button.



STEP 6

Confirm that the network displayed is your **2.4GHz Wi-Fi network**, then enter your Wi-Fi password and click "Confirm".



Once complete, your device will be connected to the network. Confirm or change the settings for your device and then click "Done". Your Studio+ is now setup and ready to use!



You can now use the app to add voice control (see pg 10), adjust settings, create custom lighting effects, set schedules, and more!

4

INSTALLATION/USES

TABLE LAMP

To use your Studio+ as a table lamp, simply attach the table stand to the bottom of the light using the included attachment screw.



CAUTION: Do not use the phone mount in this setup, the weight of some heavy phones may cause the lamp to tip forward.

PHOTO/VIDEO RING LIGHT

To use the Studio+ with the phone mount, remove the table stand and reattach it rotated 90°, then attach the phone mount to the inside of the light. Using the stand in this position will provide stability.



You can also use the light with the extendable tripod stand for either table top or floor use. The stand can extend from 16" to 46".



5

WALL LAMP

1. Determine where you would like to mount your Studio+. Make sure the location is close enough to a USB power source like a computer or an outlet with a 5V 1A USB adapter (not included).

2. Clean the mounting surface with a clean cloth and rubbing alcohol to remove any dust or oils that will weaken the adhesive. Be sure to let this surface dry before installation.

3. Peel off one of the backings of the adhesive and firmly stick it onto the back of the hanger. Then peel off the other side and firmly press it onto the wall, press for 10 seconds.

4. Hang your Studio+ on the wall hanger.

NOTE: This adhesive is not removable.



EXTENDABLE TRIPOD

1. First, unlock any locking screws that are tightened.

2. Expand the tripod base into the standing position and turn the locking screw clockwise to lock the legs in place. Make sure that the legs are expanded wide, so that they remain stable.

3. Pull up on the tripod's center pole to extend it to the desired height. Once extended, twist each locking screw to lock it in place. Ensure all parts are secure.

CAUTION: Avoid pinching in moving parts.

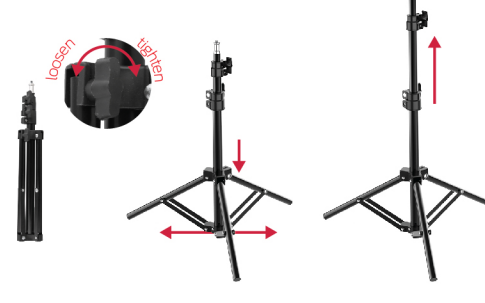

6

TROUBLESHOOTING

HAVING TROUBLE WITH SETUP?

Don't return this product to the retailer, we're here to help. Please call/write us for customer support: 866-246-2008 customer.service@monsterilluminescence.com

Q: Why is my device failing to connect to my Wi-Fi network?

- A1:** Make sure your phone or tablet is successfully connected to the **2.4GHz Wi-Fi network** that your device will be placed on.
- A2:** Make sure you enable Bluetooth and allow location services on your phone or tablet to find nearby devices.
- A3:** If your Wi-Fi network is a mixed 2.4GHz/5GHz network, try using AP pairing mode for better results.



1. In the app, select the "+" in the upper right corner of the home screen to add a new device and then select "Lighting (Wi-Fi)".
2. Click "Net Pairing Mode" in the upper right to switch to AP mode.
3. Confirm that the LED indicator is **slowly blinking**, confirm the network is your mixed Wi-Fi network, enter your Wi-Fi password, and click "Confirm".
4. Follow on-screen instructions to set up your device via wireless access point.

A4: If you still have issues with your mixed network, you may need to access your router settings and/or call your Internet Service Provider to create a separate 2.4GHz network.

Q: Can I use two Studio+ lights at once?

A1: The Studio+ is great to use in multiples, you can control each separately or easily group multiple lights together in the app to control them all as one. Click on the menu button in the upper right corner and then click "Create Group" to group your devices.



NOTE: Grouping devices with different features may cause communication issues when selecting Scenes. For best results create groups of the same or similar products or control using the Color settings.

For other frequently asked questions please visit our website at www.monsterilluminescence.com

7