



中认信通
CHINA CERTIFICATION ICT CO., LTD (DONGGUAN)



TEST REPORT

Applicant: JEM ACCESSORIES INC.

Address: 32 Brunswick Avenue, Edison, New Jersey, United States,08817

FCC ID: 2AHAS-MLB71033H

Product Name: WIFI Control 5M Light Strip

Standard(s): 47 CFR Part 15, Subpart C(15.247)

ANSI C63.10-2013

KDB 558074 D01 15.247 Meas Guidance v05r02

The above device has been tested and found compliant with the requirement of the relative standards by China Certification ICT Co., Ltd (Dongguan)

Report Number: CR231063828-00B

Date Of Issue: 2023/12/13

Reviewed By: Calvin Chen

Calvin Chen

Title: RF Engineer

Approved By: Sun Zhong

Sun Zhong

Title: Manager

Test Laboratory: China Certification ICT Co., Ltd (Dongguan)

No. 113, Pingkang Road, Dalang Town, Dongguan,

Guangdong, China

Tel: +86-769-82016888

Test Facility

The Test site used by China Certification ICT Co., Ltd (Dongguan) to collect test data is located on the No. 113, Pingkang Road, Dalang Town, Dongguan, Guangdong, China.

The lab has been recognized as the FCC accredited lab under the KDB 974614 D01 and is listed in the FCC Public Access Link (PAL) database, FCC Registration No. : 442868, the FCC Designation No. : CN1314.

The lab has been recognized by Innovation, Science and Economic Development Canada to test to Canadian radio equipment requirements, the CAB identifier: CN0123.

Declarations

China Certification ICT Co., Ltd (Dongguan) is not responsible for the authenticity of any test data provided by the applicant. Data included from the applicant that may affect test results are marked with a triangle symbol “▲”. Customer model name, addresses, names, trademarks etc. are not considered data.

Unless otherwise stated the results shown in this test report refer only to the sample(s) tested.

This report cannot be reproduced except in full, without prior written approval of the Company.

This report is valid only with a valid digital signature. The digital signature may be available only under the Adobe software above version 7.0.

This report may contain data that are not covered by the accreditation scope and shall be marked with an asterisk “★”.

CONTENTS

| | |
|---|-----------|
| DOCUMENT REVISION HISTORY | 5 |
| 1. GENERAL INFORMATION | 6 |
| 1.1 PRODUCT DESCRIPTION FOR EQUIPMENT UNDER TEST (EUT) | 6 |
| 1.2 DESCRIPTION OF TEST CONFIGURATION..... | 8 |
| 1.2.1 EUT Operation Condition:..... | 8 |
| 1.2.2 Support Equipment List and Details | 8 |
| 1.2.3 Support Cable List and Details | 8 |
| 1.2.4 Block Diagram of Test Setup..... | 9 |
| 1.3 Measurement Uncertainty | 10 |
| 2. SUMMARY OF TEST RESULTS | 11 |
| 3. REQUIREMENTS AND TEST PROCEDURES | 12 |
| 3.1 AC LINE CONDUCTED EMISSIONS..... | 12 |
| 3.1.1 Applicable Standard..... | 12 |
| 3.1.2 EUT Setup..... | 13 |
| 3.1.3 EMI Test Receiver Setup | 13 |
| 3.1.4 Test Procedure | 14 |
| 3.1.5 Corrected Amplitude & Margin Calculation..... | 14 |
| 3.2 RADIATION SPURIOUS EMISSIONS | 15 |
| 3.2.1 Applicable Standard..... | 15 |
| 3.2.2 EUT Setup..... | 15 |
| 3.2.3 EMI Test Receiver & Spectrum Analyzer Setup | 16 |
| 3.2.4 Test Procedure | 17 |
| 3.2.5 Corrected Amplitude & Margin Calculation..... | 17 |
| 3.3 MINIMUM 6 DB BANDWIDTH: | 18 |
| 3.3.1 Applicable Standard..... | 18 |
| 3.3.2 EUT Setup..... | 18 |
| 3.3.3 Test Procedure | 18 |
| 3.4 99% OCCUPIED BANDWIDTH: | 19 |
| 3.4.1 EUT Setup..... | 19 |
| 3.4.2 Test Procedure | 19 |
| 3.5 MAXIMUM CONDUCTED OUTPUT POWER: | 20 |
| 3.5.1 Applicable Standard..... | 20 |
| 3.5.2 EUT Setup..... | 20 |
| 3.5.3 Test Procedure | 20 |
| 3.6 MAXIMUM POWER SPECTRAL DENSITY: | 21 |
| 3.6.1 Applicable Standard..... | 21 |
| 3.6.2 EUT Setup..... | 21 |
| 3.6.3 Test Procedure | 21 |
| 3.7 100 KHZ BANDWIDTH OF FREQUENCY BAND EDGE: | 22 |
| 3.7.1 Applicable Standard..... | 22 |
| 3.7.2 EUT Setup..... | 22 |
| 3.7.3 Test Procedure | 22 |

3.8 DUTY CYCLE:.....23
 3.8.1 EUT Setup.....23
 3.8.2 Test Procedure23
3.9 ANTENNA REQUIREMENT.....23
 3.9.1 Applicable Standard.....23
 3.9.2 Judgment.....23
4. Test DATA AND RESULTS 24
 4.1 AC LINE CONDUCTED EMISSIONS.....24
 4.2 RADIATION SPURIOUS EMISSIONS27
 4.3 MINIMUM 6 DB EMISSION BANDWIDTH44
 4.4 99% OCCUPIED BANDWIDTH.....49
 4.5 MAXIMUM CONDUCTED OUTPUT POWER.....54
 4.6 MAXIMUM POWER SPECTRAL DENSITY55
 4.7 100 KHZ BANDWIDTH OF FREQUENCY BAND EDGE.....60
 4.8 DUTY CYCLE65
5. EUT PHOTOGRAPHS 67
6. TEST SETUP PHOTOGRAPHS 68

DOCUMENT REVISION HISTORY

| Revision Number | Report Number | Description of Revision | Date of Revision |
|-----------------|-----------------|-------------------------|------------------|
| 1.0 | CR231063828-00B | Original Report | 2023/12/13 |

1. GENERAL INFORMATION

1.1 Product Description for Equipment under Test (EUT)

| | |
|---|--|
| EUT Name: | WIFI Control 5M Light Strip |
| EUT Model: | MLB7-1033 |
| Multiple Models: | MLB7-1033-RGB, MLB7-1033-CAN |
| Operation Frequency: | 2412-2462 MHz (802.11b/g/n ht20) 2422-2452 MHz (802.11n ht40) |
| Maximum Peak Output Power (Conducted): | 21.71 dBm |
| Modulation Type: | 802.11b: DSSS-DBPSK, DQPSK, CCK 802.11g/n: OFDM-BPSK, QPSK, 16QAM, 64QAM |
| Rated Input Voltage: | DC 24V from adapter |
| Serial Number: | 2CX3-1 (for AC line Conducted Emissions Test and Radiated Spurious Emissions Test) 2CX3-2 (for RF Conducted Test) |
| EUT Received Date: | 2023/11/4 |
| EUT Received Status: | Good |
| Note: The Multiple models are electrically identical with the test model. Please refer to the declaration letter for more detail, which was provided by manufacturer. | |

Operation Frequency Detail:

For 802.11b/g/n ht20:

| Channel | Frequency (MHz) | Channel | Frequency (MHz) |
|---|-----------------|-----------------|-----------------|
| 1 | 2412 | 7 | 2442 |
| 2 | 2417 | 8 | 2447 |
| 3 | 2422 | 9 | 2452 |
| 4 | 2427 | 10 | 2457 |
| 5 | 2432 | 11 | 2462 |
| 6 | 2437 | / | / |
| Per section 15.31(m), the below frequencies were performed to test: | | | |
| Test Channel | | Frequency (MHz) | |
| Lowest | | 2412 | |
| Middle | | 2437 | |
| Highest | | 2462 | |

For 802.11n ht40:

| Channel | Frequency (MHz) | Channel | Frequency (MHz) |
|---|-----------------|-----------------|-----------------|
| 3 | 2422 | 7 | 2442 |
| 4 | 2427 | 8 | 2447 |
| 5 | 2432 | 9 | 2452 |
| 6 | 2437 | / | / |
| Per section 15.31(m), the below frequencies were performed to test: | | | |
| Test Channel | | Frequency (MHz) | |
| Lowest | | 2422 | |
| Middle | | 2437 | |
| Highest | | 2452 | |

Antenna Information Detail ▲:

| Antenna Type | input impedance (Ohm) | Frequency Range | Antenna Gain |
|--------------|-----------------------|-----------------|--------------|
| PCB | 50 | 2.4~2.5GHz | 1.84 dBi |

The Method of §15.203 Compliance:

- Antenna was permanently attached to the unit.
- Antenna use a unique type of connector to attach to the EUT.
- Unit was professionally installed, and installer shall be responsible for verifying that the correct antenna is employed with the unit.

Accessory Information:

| Accessory Description | Manufacturer | Model |
|-----------------------|-------------------------------------|-------------|
| Adapter | Shenzhen Cenwell Technology Co.,Ltd | CW2401500US |

1.2 Description of Test Configuration

1.2.1 EUT Operation Condition:

| | |
|---------------------------------|--|
| EUT Operation Mode: | The system was configured for testing in Engineering Mode, which was provided by the manufacturer. |
| Equipment Modifications: | No |
| EUT Exercise Software: | BeKen WiFi Test Tool v1.6.0 |

The software was provided by manufacturer. The maximum power was configured as below, that was provided by the manufacturer▲:

| Mode | Channel | Frequency (MHz) | Data Rate | Power Level Setting |
|--------------|---------|-----------------|-----------|---------------------|
| 802.11b | Lowest | 2412 | 1Mbps | 24 |
| | Middle | 2437 | 1Mbps | 24 |
| | Highest | 2462 | 1Mbps | 24 |
| 802.11g | Lowest | 2412 | 6Mbps | 24 |
| | Middle | 2437 | 6Mbps | 24 |
| | Highest | 2462 | 6Mbps | 24 |
| 802.11n ht20 | Lowest | 2412 | MCS0 | 24 |
| | Middle | 2437 | MCS0 | 24 |
| | Highest | 2462 | MCS0 | 24 |
| 802.11n ht40 | Lowest | 2422 | MCS0 | 22 |
| | Middle | 2437 | MCS0 | 22 |
| | Highest | 2452 | MCS0 | 22 |

Note:

1. The above are the worst-case data rates, which are determined for each mode based upon investigations by measuring the power and PSD across all data rates, bandwidths, and modulations.

1.2.2 Support Equipment List and Details

| Manufacturer | Description | Model | Serial Number |
|--------------|-------------|-------|---------------|
| / | / | / | / |

1.2.3 Support Cable List and Details

| Cable Description | Shielding Type | Ferrite Core | Length (m) | From Port | To |
|-------------------|----------------|--------------|------------|-----------|---------|
| Power Cable | No | No | 2 | EUT | Adapter |

1.2.4 Block Diagram of Test Setup

AC Line Conducted emissions:

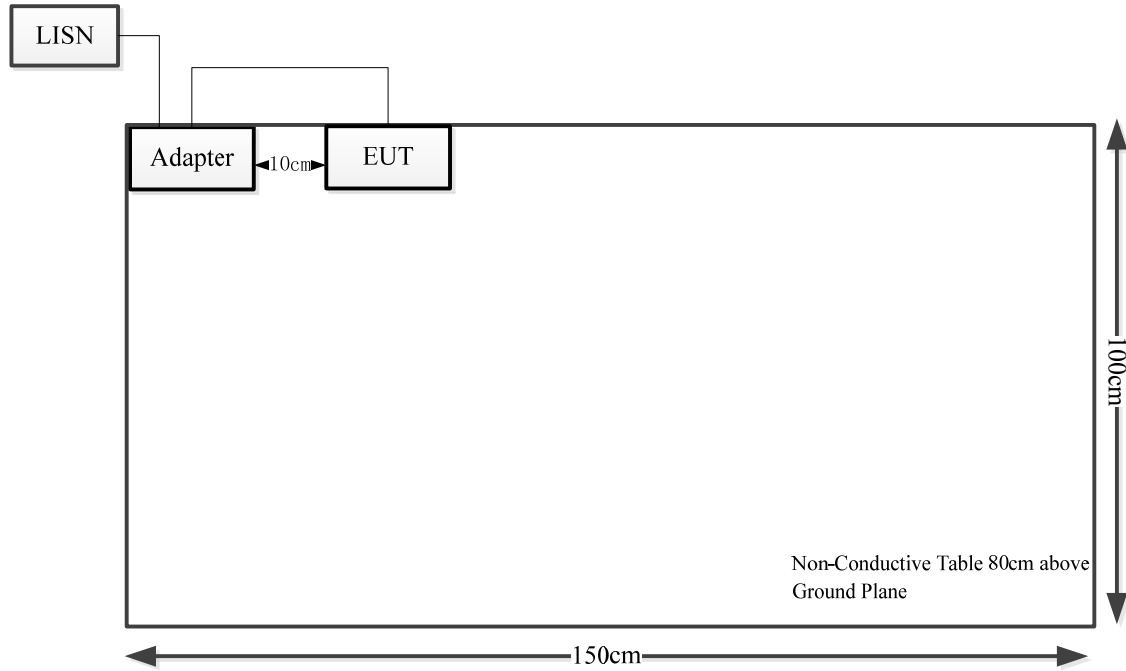

Radiated emissions:

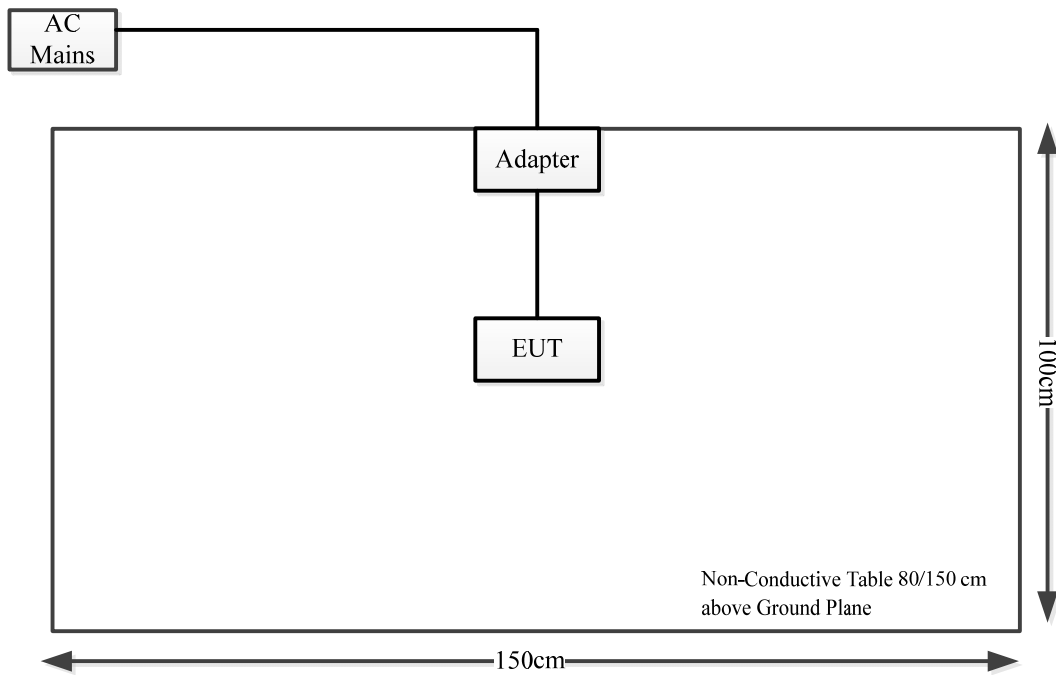

1.3 Measurement Uncertainty

Otherwise required by the applicant or Product Regulations, Decision Rule in this report did not consider the uncertainty. The extended uncertainty given in this report is obtained by combining the standard uncertainty times the coverage factor K with the 95% confidence interval.

| Parameter | Measurement Uncertainty |
|-----------------------------------|--|
| Occupied Channel Bandwidth | ±5 % |
| RF output power, conducted | ±0.61dB |
| Power Spectral Density, conducted | ±0.61 dB |
| Unwanted Emissions, radiated | 9kHz~30MHz: 4.12dB, 30M~200MHz: 4.15 dB, 200M~1GHz: 5.61 dB,1G~6GHz: 5.14 dB, 6G~18GHz: 5.93 dB, 18G~26.5G:5.47 dB,26.5G~40G:5.63 dB |
| Unwanted Emissions, conducted | ±1.26 dB |
| Temperature | ±1 °C |
| Humidity | ±5% |
| DC and low frequency voltages | ±0.4% |
| Duty Cycle | 1% |
| AC Power Lines Conducted Emission | 2.8 dB (150 kHz to 30 MHz) |

2. SUMMARY OF TEST RESULTS

| Standard(s) Section | Test Items | Result |
|---------------------------------|--|-----------|
| §15.207(a) | AC line conducted emissions | Compliant |
| §15.205, §15.209, §15.247(d) | Radiated Spurious Emissions | Compliant |
| §15.247 (a)(2) | Minimum 6 dB Bandwidth | Compliant |
| §15.247(b)(3) | Maximum Conducted Output Power | Compliant |
| §15.247(e) | Power Spectral Density | Compliant |
| §15.247(d) | 100 kHz Bandwidth of Frequency Band Edge | Compliant |
| §15.203 | Antenna Requirement | Compliant |

3. REQUIREMENTS AND TEST PROCEDURES

3.1 AC Line Conducted Emissions

3.1.1 Applicable Standard

FCC§15.207(a).

(a) Except as shown in paragraphs (b) and (c) of this section, for an intentional radiator that is designed to be connected to the public utility (AC) power line, the radio frequency voltage that is conducted back onto the AC power line on any frequency or frequencies, within the band 150 kHz to 30 MHz, shall not exceed the limits in the following table, as measured using a 50 μ H/50 ohms line impedance stabilization network (LISN). Compliance with the provisions of this paragraph shall be based on the measurement of the radio frequency voltage between each power line and ground at the power terminal. The lower limit applies at the boundary between the frequency ranges.

| Frequency of emission (MHz) | Conducted limit (dB μ V) | |
|-----------------------------|------------------------------|-----------|
| | Quasi-peak | Average |
| 0.15-0.5 | 66 to 56* | 56 to 46* |
| 0.5-5 | 56 | 46 |
| 5-30 | 60 | 50 |

*Decreases with the logarithm of the frequency.

(b) The limit shown in paragraph (a) of this section shall not apply to carrier current systems operating as intentional radiators on frequencies below 30 MHz. In lieu thereof, these carrier current systems shall be subject to the following standards:

(1) For carrier current system containing their fundamental emission within the frequency band 535-1705 kHz and intended to be received using a standard AM broadcast receiver: no limit on conducted emissions.

(2) For all other carrier current systems: 1000 μ V within the frequency band 535-1705 kHz, as measured using a 50 μ H/50 ohms LISN.

(3) Carrier current systems operating below 30 MHz are also subject to the radiated emission limits in §15.205, §15.209, §15.221, §15.223, or §15.227, as appropriate.

(c) Measurements to demonstrate compliance with the conducted limits are not required for devices which only employ battery power for operation and which do not operate from the AC power lines or contain provisions for operation while connected to the AC power lines. Devices that include, or make provisions for, the use of battery chargers which permit operating while charging, AC adapters or battery eliminators or that connect to the AC power lines indirectly, obtaining their power through another device which is connected to the AC power lines, shall be tested to demonstrate compliance with the conducted limits.

3.1.2 EUT Setup



- Note: 1. Support units were connected to second LISN.
 2. Both of LISNs (AMN) 80 cm from EUT and at the least 80 cm from other units and other metal planes support units.

The setup of EUT is according with per ANSI C63.10-2013 measurement procedure. The specification used was with the FCC Part 15.207 limits.

The spacing between the peripherals was 10 cm.

3.1.3 EMI Test Receiver Setup

The EMI test receiver was set to investigate the spectrum from 150 kHz to 30 MHz.

During the conducted emission test, the EMI test receiver was set with the following configurations:

| Frequency Range | IF B/W |
|------------------|--------|
| 150 kHz – 30 MHz | 9 kHz |

3.1.4 Test Procedure

The frequency and amplitude of the six highest ac power-line conducted emissions relative to the limit, measured over all the current-carrying conductors of the EUT power cords, and the operating frequency or frequency to which the EUT is tuned (if appropriate), should be reported, unless such emissions are more than 20 dB below the limit. AC power-line conducted emissions measurements are to be separately carried out only on each of the phase (“hot”) line(s) and (if used) on the neutral line(s), but not on the ground [protective earth] line(s). If less than six emission frequencies are within 20 dB of the limit, then the noise level of the measuring instrument at representative frequencies should be reported. The specific conductor of the power-line cord for each of the reported emissions should be identified. Measure the six highest emissions with respect to the limit on each current-carrying conductor of each power cord associated with the EUT (but not the power cords of associated or peripheral equipment that are part of the test configuration). Then, report the six highest emissions with respect to the limit from among all the measurements identifying the frequency and specific current-carrying conductor identified with the emission. The six highest emissions should be reported for each of the current-carrying conductors, or the six highest emissions may be reported over all the current-carrying conductors.

3.1.5 Corrected Amplitude & Margin Calculation

The basic equation is as follows:

Result = Reading + Factor

Factor = attenuation caused by cable loss + voltage division factor of AMN

The “**Margin**” column of the following data tables indicates the degree of compliance within the applicable limit. The equation for margin calculation is as follows:

Margin = Limit – Result

3.2 Radiation Spurious Emissions

3.2.1 Applicable Standard

FCC §15.247 (d)

In any 100 kHz bandwidth outside the frequency band in which the spread spectrum or digitally modulated intentional radiator is operating, the radio frequency power that is produced by the intentional radiator shall be at least 20 dB below that in the 100 kHz bandwidth within the band that contains the highest level of the desired power, based on either an RF conducted or a radiated measurement, provided the transmitter demonstrates compliance with the peak conducted power limits. If the transmitter complies with the conducted power limits based on the use of RMS averaging over a time interval, as permitted under paragraph (b)(3) of this section, the attenuation required under this paragraph shall be 30 dB instead of 20 dB. Attenuation below the general limits specified in §15.209(a) is not required. In addition, radiated emissions which fall in the restricted bands, as defined in §15.205(a), must also comply with the radiated emission limits specified in §15.209(a) (see §15.205(c)).

3.2.2 EUT Setup

9kHz~30MHz:

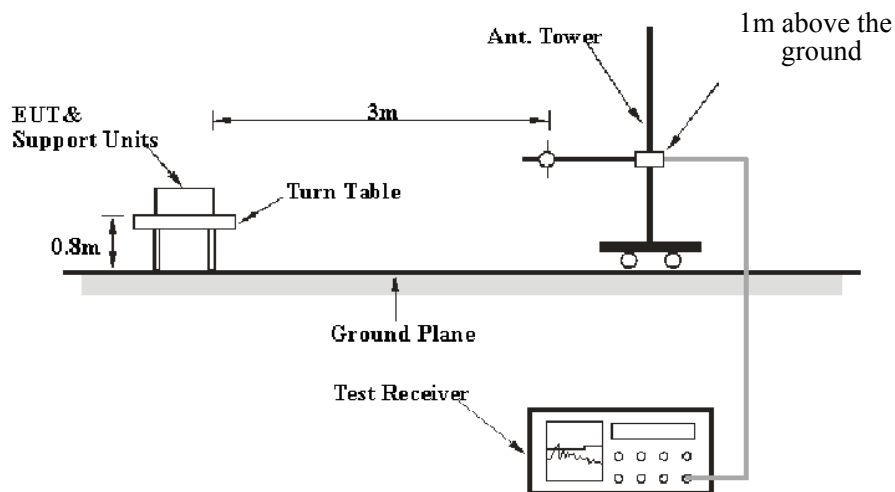

30MHz~1GHz:

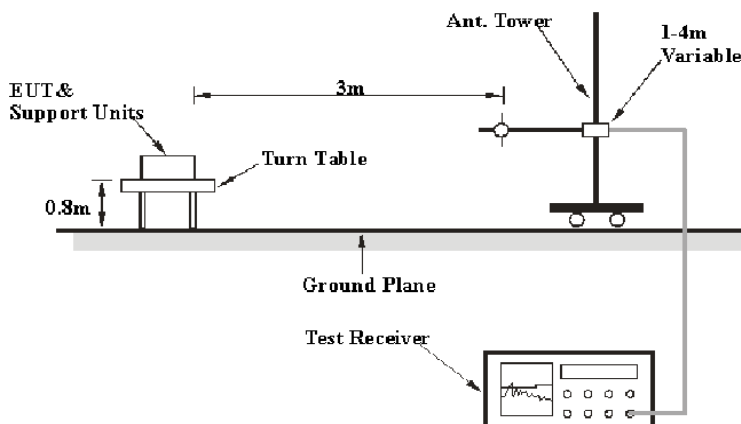

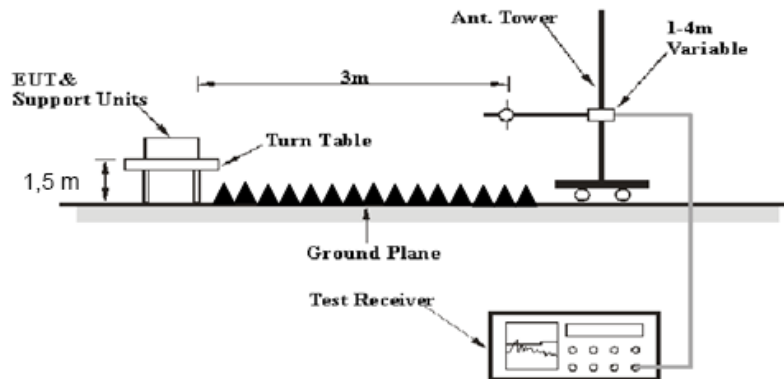
Above 1GHz:

The radiated emissions were performed in the 3 meters distance, using the setup accordance with the ANSI C63.10-2013. The specification used was the FCC 15.209, and FCC 15.247 limits.

The external I/O cables were draped along the test table and formed a bundle 30 to 40 cm long in the middle.

The spacing between the peripherals was 10 cm.

For 9kHz-30MHz test, the lowest height of the magnetic antenna shall be 1 m above the ground and three antenna orientations (parallel, perpendicular, and ground-parallel) shall be measured.

3.2.3 EMI Test Receiver & Spectrum Analyzer Setup

The system was investigated from 9kHz to 25 GHz.

During the radiated emission test, the EMI test receiver & Spectrum Analyzer Setup were set with the following configurations:

9kHz-1000MHz:

| Frequency Range | RBW | Video B/W | IF B/W | Measurement |
|-------------------|---------|-----------|---------|-------------|
| 9 kHz – 150 kHz | 300 Hz | 1 kHz | / | PK |
| | / | / | 200 Hz | QP/AV |
| 150 kHz – 30 MHz | 10 kHz | 30 kHz | / | PK |
| | / | / | 9 kHz | QP/AV |
| 30 MHz – 1000 MHz | 100 kHz | 300 kHz | / | PK |
| | / | / | 120 kHz | QP |

1GHz- 25GHz:

| Measurement | Duty cycle | RBW | Video B/W |
|-------------|------------|------|-----------|
| PK | Any | 1MHz | 3 MHz |
| AV | >98% | 1MHz | 10 Hz |
| | <98% | 1MHz | 1/T |

Note: T is minimum transmission duration

If the maximized peak measured value complies with under the QP/Average limit more than 6dB, then it is unnecessary to perform an QP/Average measurement.

The spurious emissions which below the limit more than 20dB was not be recorded.

3.2.4 Test Procedure

Maximizing procedure was performed on the highest emissions to ensure that the EUT complied with all installation combinations.

Data was recorded in Quasi-peak detection mode for frequency range of 9 kHz-1 GHz except 9–90 kHz, 110–490 kHz, employing an average detector, peak and Average detection modes for frequencies above 1 GHz.

All emissions under the average limit and under the noise floor have not recorded in the report.

3.2.5 Corrected Amplitude & Margin Calculation

The basic equation is as follows:

Result = Reading + Factor

Factor = Antenna Factor + Cable Loss- Amplifier Gain

The “**Margin**” column of the following data tables indicates the degree of compliance within the applicable limit. The equation for margin calculation is as follows:

Margin = Limit – Result

3.3 Minimum 6 dB Bandwidth:

3.3.1 Applicable Standard

FCC §15.247 (a)(2)

Systems using digital modulation techniques may operate in the 902-928 MHz, 2400-2483.5 MHz, and 5725-5850 MHz bands. The minimum 6 dB bandwidth shall be at least 500 kHz.

3.3.2 EUT Setup

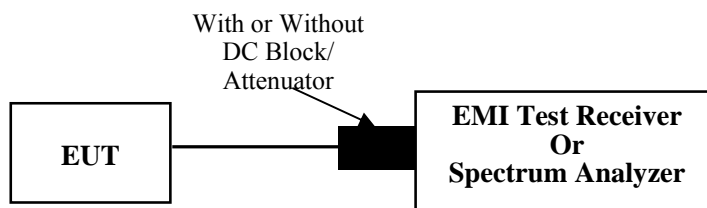

3.3.3 Test Procedure

According to ANSI C63.10-2013 Section 11.8

- a) Set RBW = 100 kHz.
- b) Set the video bandwidth (VBW) $\geq 3 \times$ RBW.
- c) Detector = Peak.
- d) Trace mode = max hold.
- e) Sweep = auto couple.
- f) Allow the trace to stabilize.
- g) Measure the maximum width of the emission that is constrained by the frequencies associated with the two outermost amplitude points (upper and lower frequencies) that are attenuated by 6 dB relative to the maximum level measured in the fundamental emission.

3.4 99% Occupied Bandwidth:

3.4.1 EUT Setup

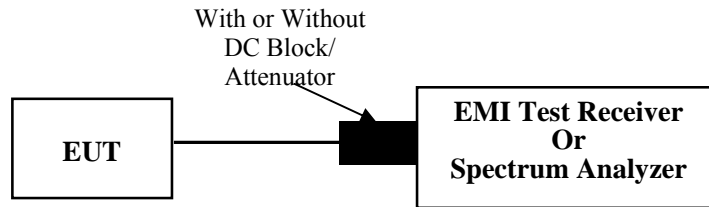

3.4.2 Test Procedure

According to ANSI C63.10-2013 Section 6.9.3

The occupied bandwidth is the frequency bandwidth such that, below its lower and above its upper frequency limits, the mean powers are each equal to 0.5% of the total mean power of the given emission. The following procedure shall be used for measuring 99% power bandwidth:

- a) The instrument center frequency is set to the nominal EUT channel center frequency. The frequency span for the spectrum analyzer shall be between 1.5 times and 5.0 times the OBW.
- b) The nominal IF filter bandwidth (3 dB RBW) shall be in the range of 1% to 5% of the OBW, and VBW shall be approximately three times the RBW, unless otherwise specified by the applicable requirement.
- c) Set the reference level of the instrument as required, keeping the signal from exceeding the maximum input mixer level for linear operation. In general, the peak of the spectral envelope shall be more than $[10 \log (OBW/RBW)]$ below the reference level. Specific guidance is given in 4.1.5.2.
- d) Step a) through step c) might require iteration to adjust within the specified range.
- e) Video averaging is not permitted. Where practical, a sample detection and single sweep mode shall be used. Otherwise, peak detection and max hold mode (until the trace stabilizes) shall be used.
- f) Use the 99% power bandwidth function of the instrument (if available) and report the measured bandwidth.
- g) If the instrument does not have a 99% power bandwidth function, then the trace data points are recovered and directly summed in linear power terms. The recovered amplitude data points, beginning at the lowest frequency, are placed in a running sum until 0.5% of the total is reached; that frequency is recorded as the lower frequency. The process is repeated until 99.5% of the total is reached; that frequency is recorded as the upper frequency. The 99% power bandwidth is the difference between these two frequencies.
- h) The occupied bandwidth shall be reported by providing plot(s) of the measuring instrument display; the plot axes and the scale units per division shall be clearly labeled. Tabular data may be reported in addition to the plot(s).

3.5 Maximum Conducted Output Power:

3.5.1 Applicable Standard

FCC §15.247 (b)(3)

For systems using digital modulation in the 902-928 MHz, 2400-2483.5 MHz, and 5725-5850 MHz bands: 1 Watt. As an alternative to a peak power measurement, compliance with the one Watt limit can be based on a measurement of the maximum conducted output power. Maximum Conducted Output Power is defined as the total transmit power delivered to all antennas and antenna elements averaged across all symbols in the signaling alphabet when the transmitter is operating at its maximum power control level. Power must be summed across all antennas and antenna elements. The average must not include any time intervals during which the transmitter is off or is transmitting at a reduced power level. If multiple modes of operation are possible (e.g., alternative modulation methods), the maximum conducted output power is the highest total transmit power occurring in any mode.

3.5.2 EUT Setup

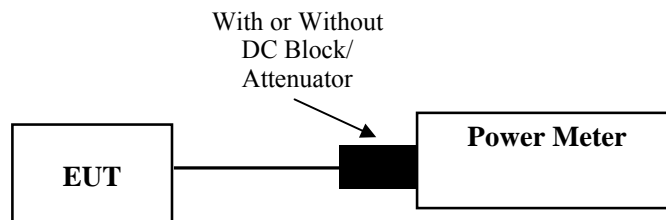

3.5.3 Test Procedure

According to ANSI C63.10-2013 Section 11.9.2.3.2

Method AVGPM-G is a measurement using a gated RF average power meter.

Alternatively, measurements may be performed using a wideband gated RF power meter provided that the gate parameters are adjusted such that the power is measured only when the EUT is transmitting at its maximum power control level. Because the measurement is made only during the ON time of the transmitter, no duty cycle correction factor is required.

According to ANSI C63.10-2013 Section 11.9.1.3

The maximum peak conducted output power may be measured using a broadband peak RF power meter. The power meter shall have a video bandwidth that is greater than or equal to the DTS bandwidth and shall use a fast-responding diode detector.

- a) Set the EUT in transmitting mode.
- b) Remove the antenna from the EUT and then connect a low loss RF cable from the antenna port to test equipment.
- c) Add a correction factor to the display.
- d) Set the power meter to test peak output power, record the result.

3.6 Maximum Power Spectral Density:

3.6.1 Applicable Standard

FCC §15.247 (e)

For digitally modulated systems, the power spectral density conducted from the intentional radiator to the antenna shall not be greater than 8 dBm in any 3 kHz band during any time interval of continuous transmission. This power spectral density shall be determined in accordance with the provisions of paragraph (b) of this section. The same method of determining the conducted output power shall be used to determine the power spectral density.

3.6.2 EUT Setup

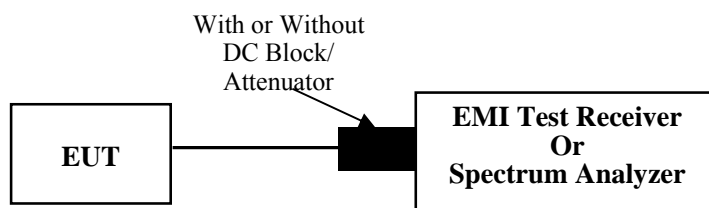

3.6.3 Test Procedure

According to ANSI C63.10-2013 Section 11.10.2

- a) Set analyzer center frequency to DTS channel center frequency.
- b) Set the span to 1.5 times the DTS bandwidth.
- c) Set the RBW to $3 \text{ kHz} \leq \text{RBW} \leq 100 \text{ kHz}$.
- d) Set the VBW $\geq [3 \cdot \text{RBW}]$.
- e) Detector = peak.
- f) Sweep time = auto couple.
- g) Trace mode = max hold.
- h) Allow trace to fully stabilize.
- i) Use the peak marker function to determine the maximum amplitude level within the RBW.
- j) If measured value exceeds requirement, then reduce RBW (but no less than 3 kHz) and repeat.

3.7 100 kHz Bandwidth of Frequency Band Edge:

3.7.1 Applicable Standard

FCC §15.247 (d);

In any 100 kHz bandwidth outside the frequency band in which the spread spectrum or digitally modulated intentional radiator is operating, the radio frequency power that is produced by the intentional radiator shall be at least 20 dB below that in the 100 kHz bandwidth within the band that contains the highest level of the desired power, based on either an RF conducted or a radiated measurement, provided the transmitter demonstrates compliance with the peak conducted power limits. If the transmitter complies with the conducted power limits based on the use of RMS averaging over a time interval, as permitted under paragraph (b)(3) of this section, the attenuation required under this paragraph shall be 30 dB instead of 20 dB. Attenuation below the general limits specified in §15.209(a) is not required. In addition, radiated emissions which fall in the restricted bands, as defined in §15.205(a), must also comply with the radiated emission limits specified in §15.209(a) (see §15.205(c)).

3.7.2 EUT Setup

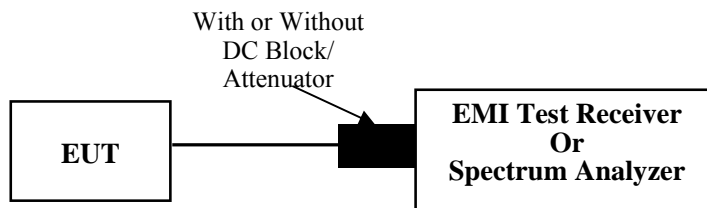

3.7.3 Test Procedure

According to ANSI C63.10-2013 Section 11.11

- a) Set the center frequency and span to encompass frequency range to be measured.
- b) Set the RBW = 100 kHz.
- c) Set the VBW $\geq [3 \times \text{RBW}]$.
- d) Detector = peak.
- e) Sweep time = auto couple.
- f) Trace mode = max hold.
- g) Allow trace to fully stabilize.
- h) Use the peak marker function to determine the maximum amplitude level.

Ensure that the amplitude of all unwanted emissions outside of the authorized frequency band (excluding restricted frequency bands) is attenuated by at least the minimum requirements specified in 11.11. Report the three highest emissions relative to the limit.

3.8 Duty Cycle:

3.8.1 EUT Setup

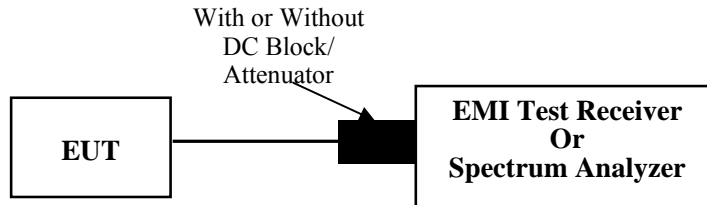

3.8.2 Test Procedure

According to ANSI C63.10-2013 Section 11.6

The zero-span mode on a spectrum analyzer or EMI receiver if the response time and spacing between bins on the sweep are sufficient to permit accurate measurements of the ON and OFF times of the transmitted signal:

- 1) Set the center frequency of the instrument to the center frequency of the transmission.
- 2) Set $RBW \geq OBW$ if possible; otherwise, set RBW to the largest available value.
- 3) Set $VBW \geq RBW$. Set detector = peak or average.
- 4) The zero-span measurement method shall not be used unless both RBW and VBW are $> 50/T$ and the number of sweep points across duration T exceeds 100. (For example, if VBW and/or RBW are limited to 3 MHz, then the zero-span method of measuring the duty cycle shall not be used if $T \leq 16.7 \mu s$.)

3.9 Antenna Requirement

3.9.1 Applicable Standard

FCC §15.203

An intentional radiator shall be designed to ensure that no antenna other than that furnished by the responsible party shall be used with the device. The use of a permanently attached antenna or of an antenna that uses a unique coupling to the intentional radiator shall be considered sufficient to comply with the provisions of this section. The manufacturer may design the unit so that a broken antenna can be replaced by the user, but the use of a standard antenna jack or electrical connector is prohibited. This requirement does not apply to carrier current devices or to devices operated under the provisions of §§15.211, 15.213, 15.217, 15.219, 15.221, or §15.236. Further, this requirement does not apply to intentional radiators that must be professionally installed, such as perimeter protection systems and some field disturbance sensors, or to other intentional radiators which, in accordance with §15.31(d), must be measured at the installation site. However, the installer shall be responsible for ensuring that the proper antenna is employed so that the limits in this part are not exceeded.

3.9.2 Judgment

Compliant. Please refer to the Antenna Information detail in Section 1.

4. Test DATA AND RESULTS

4.1 AC Line Conducted Emissions

| | | | |
|----------------|-------------|--------------|---|
| Serial Number: | 2CX3-1 | Test Date: | 2023/11/18 |
| Test Site: | CE | Test Mode: | Transmitting(Maximum Output Power Mode,802.11b, Middle Channel) |
| Tester: | David Huang | Test Result: | Pass |

Environmental Conditions:

| | | | | | |
|----------------------|------|---------------------------|----|------------------------|-------|
| Temperature: (°C) | 24.8 | Relative Humidity: (%) | 32 | ATM Pressure: (kPa) | 101.8 |
|----------------------|------|---------------------------|----|------------------------|-------|

Test Equipment List and Details:

| Manufacturer | Description | Model | Serial Number | Calibration Date | Calibration Due Date |
|--------------|-------------------|---------|---------------|------------------|----------------------|
| R&S | LISN | ENV216 | 101132 | 2023/3/31 | 2024/3/30 |
| R&S | EMI Test Receiver | ESR3 | 102726 | 2023/3/31 | 2024/3/30 |
| MICRO-COAX | Coaxial Cable | UTIFLEX | C-0200-01 | 2023/8/6 | 2024/8/5 |
| Audix | Test Software | E3 | 190306 (V9) | N/A | N/A |

* Statement of Traceability: China Certification ICT Co., Ltd (Dongguan) attests that all calibrations have been performed, traceable to National Primary Standards and International System of Units (SI).

Test Data:

Project No.: CR231063828-RF
 Tester: David Huang
 Port: Line
 Note: Transmitting(2.4G WIFI)

Date: 2023-11-18

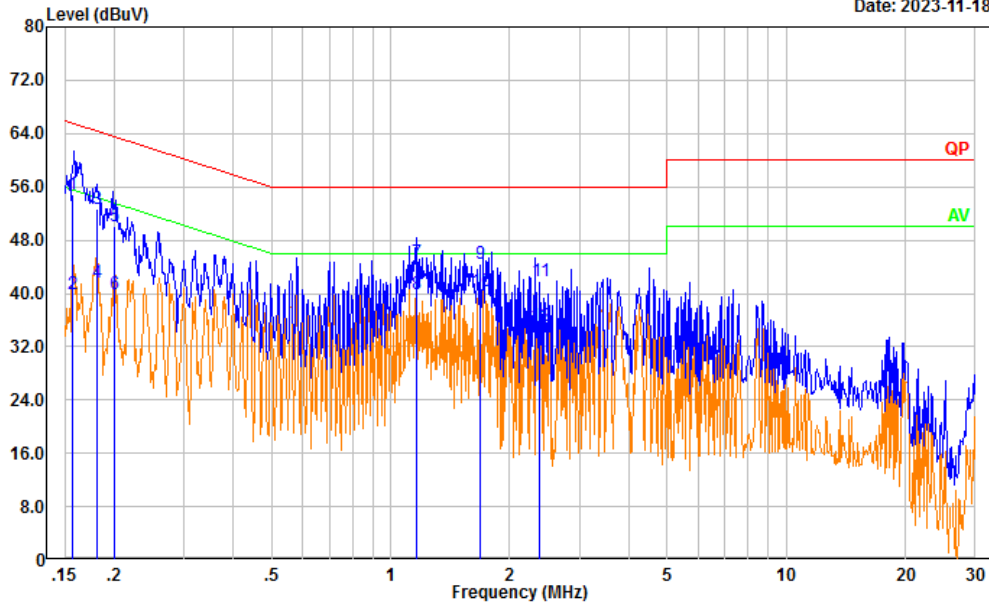

| No. | Frequency (MHz) | Reading (dBμV) | Factor (dB) | Result (dBμV) | Limit (dBμV) | Margin (dB) | Detector |
|-----|-----------------|----------------|-------------|---------------|--------------|-------------|----------|
| 1 | 0.157 | 45.29 | 9.61 | 54.90 | 65.60 | 10.70 | QP |
| 2 | 0.157 | 30.36 | 9.61 | 39.97 | 55.60 | 15.63 | Average |
| 3 | 0.181 | 43.16 | 9.61 | 52.77 | 64.45 | 11.68 | QP |
| 4 | 0.181 | 32.07 | 9.61 | 41.68 | 54.45 | 12.77 | Average |
| 5 | 0.201 | 40.53 | 9.61 | 50.14 | 63.58 | 13.44 | QP |
| 6 | 0.201 | 30.17 | 9.61 | 39.78 | 53.58 | 13.80 | Average |
| 7 | 1.158 | 34.95 | 9.62 | 44.57 | 56.00 | 11.43 | QP |
| 8 | 1.158 | 30.18 | 9.62 | 39.80 | 46.00 | 6.20 | Average |
| 9 | 1.680 | 34.71 | 9.63 | 44.34 | 56.00 | 11.66 | QP |
| 10 | 1.680 | 30.68 | 9.63 | 40.31 | 46.00 | 5.69 | Average |
| 11 | 2.380 | 32.14 | 9.64 | 41.78 | 56.00 | 14.22 | QP |
| 12 | 2.380 | 25.50 | 9.64 | 35.14 | 46.00 | 10.86 | Average |

Project No.: CR231063828-RF
 Tester: David Huang
 Port: neutral
 Note: Transmitting(2.4G WIFI)

Date: 2023-11-18

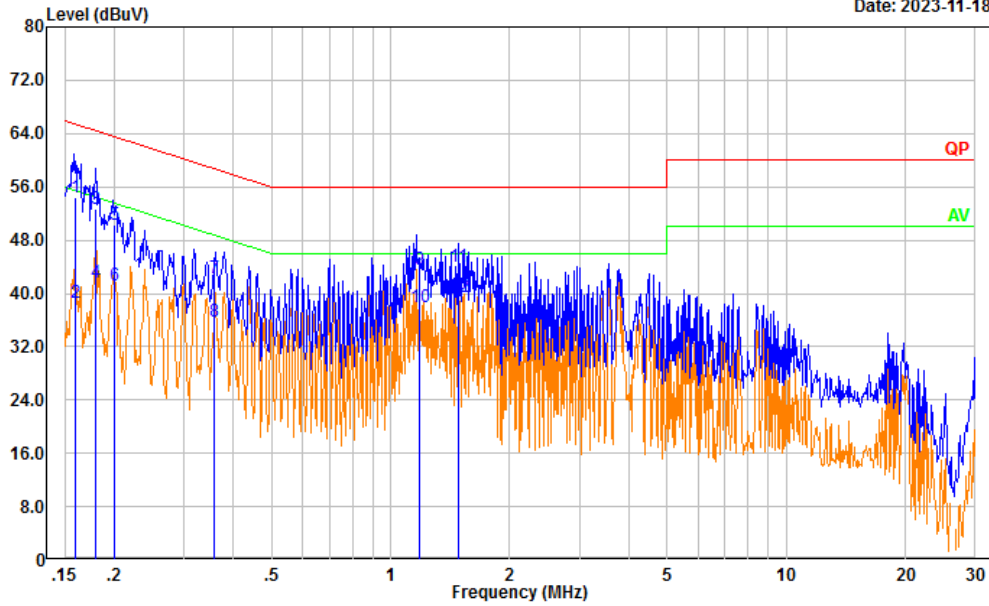

| No. | Frequency (MHz) | Reading (dBμV) | Factor (dB) | Result (dBμV) | Limit (dBμV) | Margin (dB) | Detector |
|-----|-----------------|----------------|-------------|---------------|--------------|-------------|----------|
| 1 | 0.159 | 44.84 | 9.61 | 54.45 | 65.49 | 11.04 | QP |
| 2 | 0.159 | 29.04 | 9.61 | 38.65 | 55.49 | 16.84 | Average |
| 3 | 0.180 | 43.13 | 9.61 | 52.74 | 64.49 | 11.75 | QP |
| 4 | 0.180 | 31.92 | 9.61 | 41.53 | 54.49 | 12.96 | Average |
| 5 | 0.200 | 40.78 | 9.61 | 50.39 | 63.60 | 13.21 | QP |
| 6 | 0.200 | 31.69 | 9.61 | 41.30 | 53.60 | 12.30 | Average |
| 7 | 0.359 | 32.74 | 9.61 | 42.35 | 58.76 | 16.41 | QP |
| 8 | 0.359 | 26.10 | 9.61 | 35.71 | 48.76 | 13.05 | Average |
| 9 | 1.180 | 33.94 | 9.62 | 43.56 | 56.00 | 12.44 | QP |
| 10 | 1.180 | 28.25 | 9.62 | 37.87 | 46.00 | 8.13 | Average |
| 11 | 1.480 | 34.33 | 9.62 | 43.95 | 56.00 | 12.05 | QP |
| 12 | 1.480 | 29.85 | 9.62 | 39.47 | 46.00 | 6.53 | Average |

4.2 Radiation Spurious Emissions

| | | | |
|----------------|-------------------|--------------|---|
| Serial Number: | 2CX3-1 | Test Date: | Below 1GHz: 2023/12/8 Above 1GHz: 2023/11/25 |
| Test Site: | 966-2,966-1 | Test Mode: | Transmitting |
| Tester: | Jeff Luo, Tao Zhu | Test Result: | Pass |

Environmental Conditions:

| | | | | | |
|----------------------|-----------|---------------------------|-------|------------------------|-------------|
| Temperature: (°C) | 25.1~25.3 | Relative Humidity: (%) | 45~57 | ATM Pressure: (kPa) | 101.1~101.4 |
|----------------------|-----------|---------------------------|-------|------------------------|-------------|

Test Equipment List and Details:

| Manufacturer | Description | Model | Serial Number | Calibration Date | Calibration Due Date |
|--|------------------------------------|---------------------------|---------------|------------------|----------------------|
| Radiation Spurious Emissions Below 1GHz | | | | | |
| Sunol Sciences | Antenna | JB6 | A082520-6 | 2023/9/18 | 2026/9/17 |
| BACL | Loop Antenna | 1313-1P | 3092721 | 2023/10/20 | 2026/10/19 |
| R&S | EMI Test Receiver | ESR3 | 102724 | 2023/3/31 | 2024/3/30 |
| TIMES MICROWAVE | Coaxial Cable | LMR-600- UltraFlex | C-0470-02 | 2023/7/16 | 2024/7/15 |
| TIMES MICROWAVE | Coaxial Cable | LMR-600- UltraFlex | C-0780-01 | 2023/7/16 | 2024/7/15 |
| Sonoma | Amplifier | 310N | 186165 | 2023/7/16 | 2024/7/15 |
| Audix | Test Software | E3 | 201021 (V9) | N/A | N/A |
| Radiation Spurious Emissions Above 1GHz | | | | | |
| AH | Double Ridge Guide Horn Antenna | SAS-571 | 1394 | 2023/2/22 | 2026/2/21 |
| R&S | Spectrum Analyzer | FSV40 | 101591 | 2023/3/31 | 2024/3/30 |
| MICRO-COAX | Coaxial Cable | UFA210A-1-1200- 70U300 | 217423-008 | 2023/8/6 | 2024/8/5 |
| MICRO-COAX | Coaxial Cable | UFA210A-1-2362- 300300 | 235780-001 | 2023/8/6 | 2024/8/5 |
| Mini | Pre-amplifier | ZVA-183-S+ | 5969001149 | 2023/11/8 | 2024/11/7 |
| Audix | Test Software | E3 | 201021 (V9) | N/A | N/A |
| PASTERNAK | Horn Antenna | PE9852/2F-20 | 112002 | 2021/2/5 | 2024/2/4 |
| Quinstar | Preamplifier | QLW-18405536-JO | 15964001005 | 2023/9/15 | 2024/9/14 |
| MICRO-COAX | Coaxial Cable | UFB142A-1-2362- 200200 | 235772-001 | 2023/8/6 | 2024/8/5 |
| E-Microwave | Band Rejection Filter | 2400-2483.5MHz | OE01902424 | 2023/8/6 | 2024/8/5 |
| Mini Circuits | High Pass Filter | VHF-6010+ | 31119 | 2023/8/6 | 2024/8/5 |

* Statement of Traceability: China Certification ICT Co., Ltd (Dongguan) attests that all calibrations have been performed, traceable to National Primary Standards and International System of Units (SI).

Test Data:

Please refer to the below table and plots.

After pre-scan in the X, Y and Z axes of orientation, the worst case is below:

For 9kHz-30MHz, The amplitude of spurious emissions attenuated more than 20 dB below the limit was not be recorded.

1) 30MHz-1GHz (Maximum Output Power Mode, 802.11b Mode)

Low channel:

Project No.: CR231063828-RF
 Tester: Jeff Luo
 Polarization: horizontal
 Note: Transmitting(2.4G WIFI 802.11b Mode)

Date: 2023-12-08

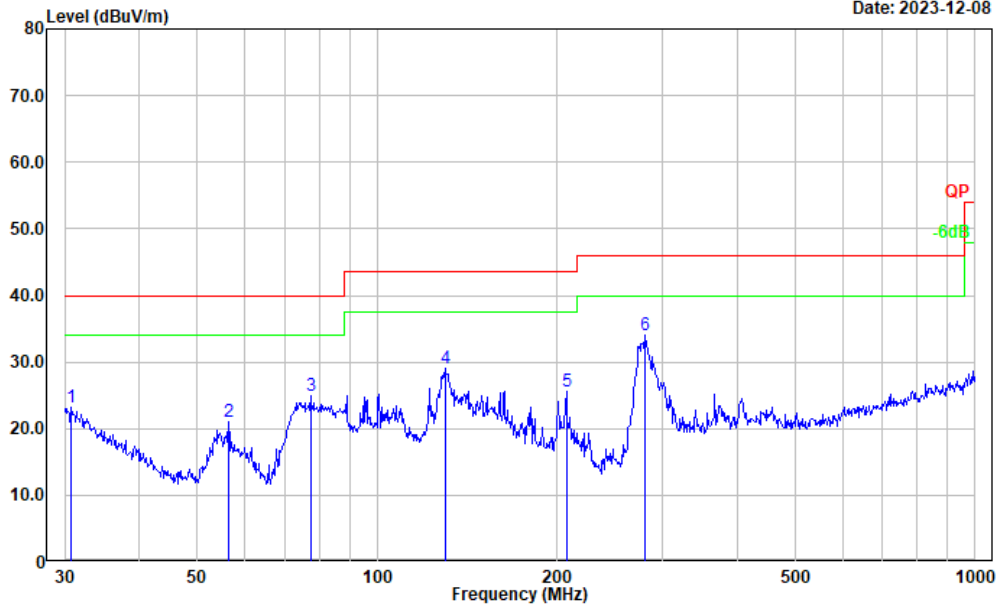

| No. | Frequency (MHz) | Reading (dBμV) | Factor (dB/m) | Result (dBμV/m) | Limit (dBμV/m) | Margin (dB) | Detector |
|-----|-----------------|----------------|---------------|-----------------|----------------|-------------|----------|
| 1 | 30.745 | 27.61 | -4.47 | 23.14 | 40.00 | 16.86 | Peak |
| 2 | 56.395 | 38.45 | -17.37 | 21.08 | 40.00 | 18.92 | Peak |
| 3 | 77.321 | 42.36 | -17.38 | 24.98 | 40.00 | 15.02 | Peak |
| 4 | 129.923 | 40.58 | -11.51 | 29.07 | 43.50 | 14.43 | Peak |
| 5 | 207.123 | 38.25 | -12.72 | 25.53 | 43.50 | 17.97 | Peak |
| 6 | 280.024 | 46.16 | -12.02 | 34.14 | 46.00 | 11.86 | Peak |

Project No.: CR231063828-RF
 Tester: Jeff Luo
 Polarization: vertical
 Note: Transmitting(2.4G WIFI 802.11b Mode)

Date: 2023-12-08

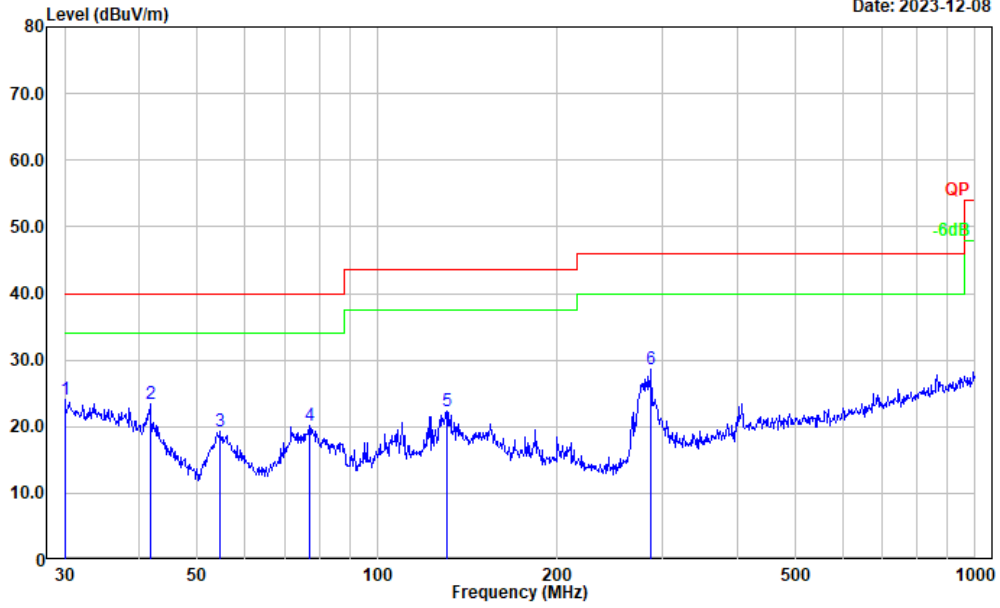

| No. | Frequency (MHz) | Reading (dBμV) | Factor (dB/m) | Result (dBμV/m) | Limit (dBμV/m) | Margin (dB) | Detector |
|-----|-----------------|----------------|---------------|-----------------|----------------|-------------|----------|
| 1 | 30.000 | 27.95 | -3.91 | 24.04 | 40.00 | 15.96 | Peak |
| 2 | 41.713 | 35.99 | -12.50 | 23.49 | 40.00 | 16.51 | Peak |
| 3 | 54.643 | 36.69 | -17.33 | 19.36 | 40.00 | 20.64 | Peak |
| 4 | 77.051 | 37.53 | -17.34 | 20.19 | 40.00 | 19.81 | Peak |
| 5 | 130.837 | 33.82 | -11.53 | 22.29 | 43.50 | 21.21 | Peak |
| 6 | 286.982 | 40.11 | -11.55 | 28.56 | 46.00 | 17.44 | Peak |

Middle channel:

Project No.: CR231063828-RF
 Tester: Jeff Luo
 Polarization: horizontal
 Note: Transmitting(2.4G WIFI 802.11b Mode)

Date: 2023-12-08

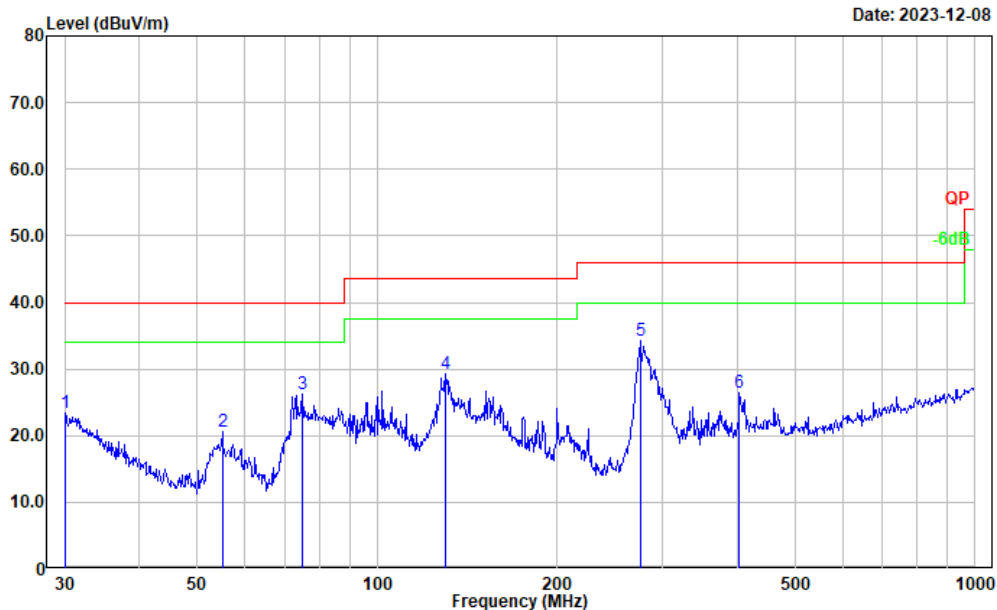

| No. | Frequency (MHz) | Reading (dBμV) | Factor (dB/m) | Result (dBμV/m) | Limit (dBμV/m) | Margin (dB) | Detector |
|-----|-----------------|----------------|---------------|-----------------|----------------|-------------|----------|
| 1 | 30.000 | 27.43 | -3.91 | 23.52 | 40.00 | 16.48 | Peak |
| 2 | 55.027 | 37.97 | -17.34 | 20.63 | 40.00 | 19.37 | Peak |
| 3 | 74.919 | 43.38 | -17.14 | 26.24 | 40.00 | 13.76 | Peak |
| 4 | 130.379 | 40.89 | -11.53 | 29.36 | 43.50 | 14.14 | Peak |
| 5 | 275.157 | 46.41 | -12.25 | 34.16 | 46.00 | 11.84 | Peak |
| 6 | 403.250 | 35.43 | -9.00 | 26.43 | 46.00 | 19.57 | Peak |

Project No.: CR231063828-RF
 Tester: Jeff Luo
 Polarization: vertical
 Note: Transmitting(2.4G WIFI 802.11b Mode)

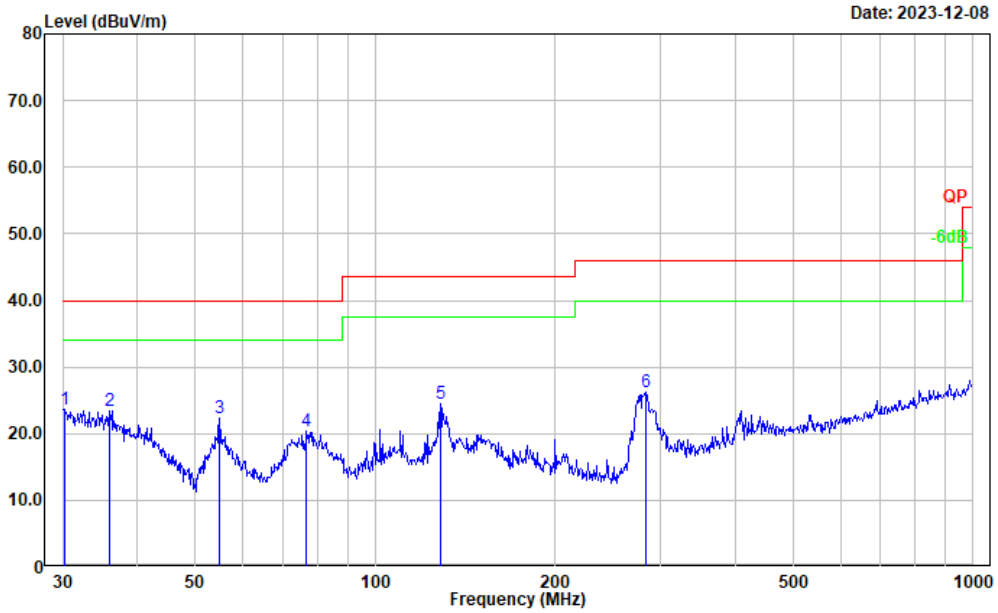

| No. | Frequency (MHz) | Reading (dBμV) | Factor (dB/m) | Result (dBμV/m) | Limit (dBμV/m) | Margin (dB) | Detector |
|-----|-----------------|----------------|---------------|-----------------|----------------|-------------|----------|
| 1 | 30.317 | 27.79 | -4.15 | 23.64 | 40.00 | 16.36 | Peak |
| 2 | 36.001 | 31.99 | -8.49 | 23.50 | 40.00 | 16.50 | Peak |
| 3 | 54.835 | 39.65 | -17.34 | 22.31 | 40.00 | 17.69 | Peak |
| 4 | 76.781 | 37.78 | -17.32 | 20.46 | 40.00 | 19.54 | Peak |
| 5 | 128.563 | 35.94 | -11.51 | 24.43 | 43.50 | 19.07 | Peak |
| 6 | 282.985 | 37.99 | -11.81 | 26.18 | 46.00 | 19.82 | Peak |

High channel:

Project No.: CR231063828-RF
 Tester: Jeff Luo
 Polarization: horizontal
 Note: Transmitting(2.4G WIFI 802.11b Mode)

Date: 2023-12-08

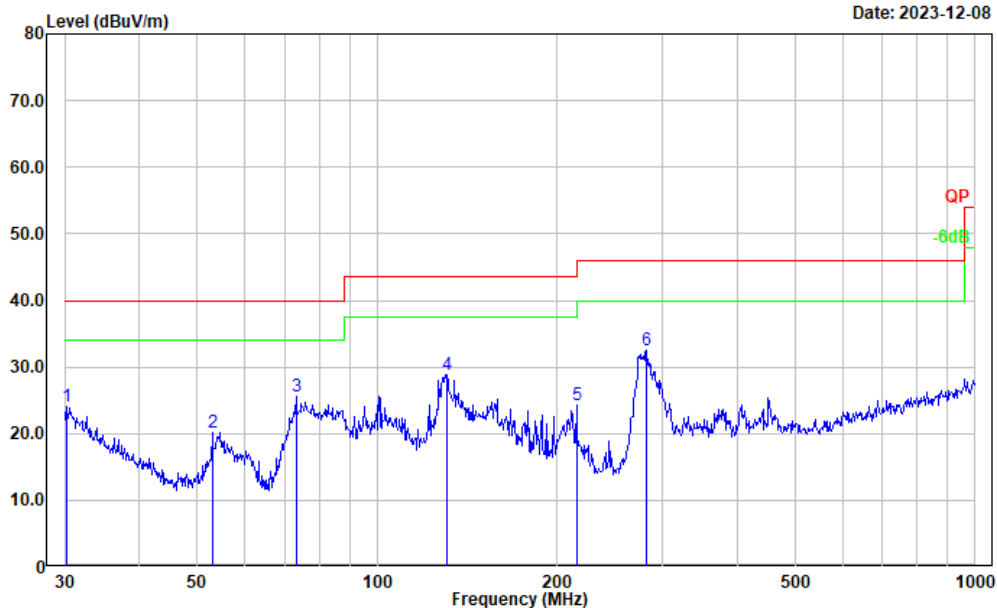

| No. | Frequency (MHz) | Reading (dBμV) | Factor (dB/m) | Result (dBμV/m) | Limit (dBμV/m) | Margin (dB) | Detector |
|-----|-----------------|----------------|---------------|-----------------|----------------|-------------|----------|
| 1 | 30.317 | 28.18 | -4.15 | 24.03 | 40.00 | 15.97 | Peak |
| 2 | 52.945 | 37.44 | -17.29 | 20.15 | 40.00 | 19.85 | Peak |
| 3 | 73.103 | 42.55 | -16.99 | 25.56 | 40.00 | 14.44 | Peak |
| 4 | 130.837 | 40.40 | -11.53 | 28.87 | 43.50 | 14.63 | Peak |
| 5 | 215.268 | 37.17 | -12.96 | 24.21 | 43.50 | 19.29 | Peak |
| 6 | 281.995 | 44.39 | -11.87 | 32.52 | 46.00 | 13.48 | Peak |

Project No.: CR231063828-RF
 Tester: Jeff Luo
 Polarization: vertical
 Note: Transmitting(2.4G WIFI 802.11b Mode)

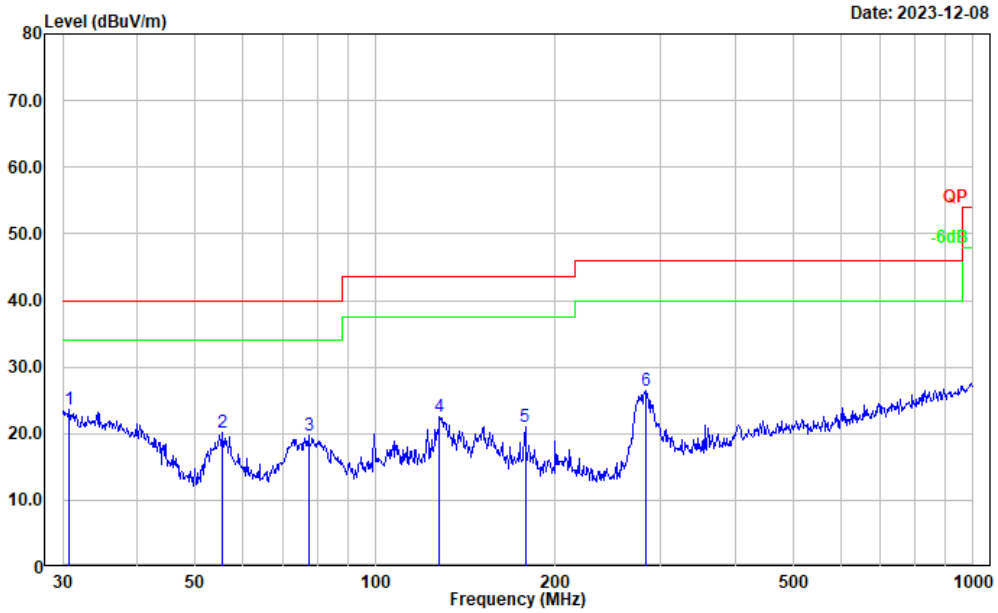

| No. | Frequency (MHz) | Reading (dBμV) | Factor (dB/m) | Result (dBμV/m) | Limit (dBμV/m) | Margin (dB) | Detector |
|-----|-----------------|----------------|---------------|-----------------|----------------|-------------|----------|
| 1 | 30.745 | 28.04 | -4.47 | 23.57 | 40.00 | 16.43 | Peak |
| 2 | 55.609 | 37.48 | -17.36 | 20.12 | 40.00 | 19.88 | Peak |
| 3 | 77.321 | 37.05 | -17.38 | 19.67 | 40.00 | 20.33 | Peak |
| 4 | 128.113 | 33.93 | -11.49 | 22.44 | 43.50 | 21.06 | Peak |
| 5 | 178.133 | 34.69 | -13.65 | 21.04 | 43.50 | 22.46 | Peak |
| 6 | 282.985 | 38.20 | -11.81 | 26.39 | 46.00 | 19.61 | Peak |

**3) 1-25GHz:
802.11b Mode**

| Frequency (MHz) | Receiver | | Polar (H/V) | Factor (dB/m) | Result (dB μ V/m) | Limit (dB μ V/m) | Margin (dB) |
|--------------------------|----------------------|----------|-------------|---------------|-----------------------|----------------------|-------------|
| | Reading (dB μ V) | Detector | | | | | |
| Low Channel: 2412 MHz | | | | | | | |
| 2390.000 | 27.20 | PK | H | 31.71 | 58.91 | 74.00 | 15.09 |
| 2390.000 | 14.15 | AV | H | 31.71 | 45.86 | 54.00 | 8.14 |
| 2390.000 | 26.96 | PK | V | 31.71 | 58.67 | 74.00 | 15.33 |
| 2390.000 | 14.06 | AV | V | 31.71 | 45.77 | 54.00 | 8.23 |
| 4824.000 | 38.12 | PK | H | 11.26 | 49.38 | 74.00 | 24.62 |
| 4824.000 | 30.20 | AV | H | 11.26 | 41.46 | 54.00 | 12.54 |
| 4824.000 | 37.66 | PK | V | 11.26 | 48.92 | 74.00 | 25.08 |
| 4824.000 | 29.65 | AV | V | 11.26 | 40.91 | 54.00 | 13.09 |
| 7236.000 | 45.21 | PK | H | 15.24 | 60.45 | 74.00 | 13.55 |
| 7236.000 | 34.17 | AV | H | 15.24 | 49.41 | 54.00 | 4.59 |
| 7236.000 | 44.10 | PK | V | 15.24 | 59.34 | 74.00 | 14.66 |
| 7236.000 | 34.82 | AV | V | 15.24 | 50.06 | 54.00 | 3.94 |
| Middle Channel: 2437 MHz | | | | | | | |
| 4874.000 | 38.42 | PK | H | 11.45 | 49.87 | 74.00 | 24.13 |
| 4874.000 | 29.66 | AV | H | 11.45 | 41.11 | 54.00 | 12.89 |
| 4874.000 | 37.64 | PK | V | 11.45 | 49.09 | 74.00 | 24.91 |
| 4874.000 | 29.01 | AV | V | 11.45 | 40.46 | 54.00 | 13.54 |
| 7311.000 | 45.36 | PK | H | 15.58 | 60.94 | 74.00 | 13.06 |
| 7311.000 | 34.25 | AV | H | 15.58 | 49.83 | 54.00 | 4.17 |
| 7311.000 | 43.55 | PK | V | 15.58 | 59.13 | 74.00 | 14.87 |
| 7311.000 | 34.28 | AV | V | 15.58 | 49.86 | 54.00 | 4.14 |
| High Channel: 2462 MHz | | | | | | | |
| 2483.500 | 28.86 | PK | H | 32.19 | 61.05 | 74.00 | 12.95 |
| 2483.500 | 16.71 | AV | H | 32.19 | 48.90 | 54.00 | 5.10 |
| 2483.500 | 27.69 | PK | V | 32.19 | 59.88 | 74.00 | 14.12 |
| 2483.500 | 15.49 | AV | V | 32.19 | 47.68 | 54.00 | 6.32 |
| 4924.000 | 38.52 | PK | H | 11.67 | 50.19 | 74.00 | 23.81 |
| 4924.000 | 29.66 | AV | H | 11.67 | 41.33 | 54.00 | 12.67 |
| 4924.000 | 37.41 | PK | V | 11.67 | 49.08 | 74.00 | 24.92 |
| 4924.000 | 28.42 | AV | V | 11.67 | 40.09 | 54.00 | 13.91 |
| 7386.000 | 45.36 | PK | H | 15.63 | 60.99 | 74.00 | 13.01 |
| 7386.000 | 35.36 | AV | H | 15.63 | 50.99 | 54.00 | 3.01 |
| 7386.000 | 43.78 | PK | V | 15.63 | 59.41 | 74.00 | 14.59 |
| 7386.000 | 34.62 | AV | V | 15.63 | 50.25 | 54.00 | 3.75 |

802.11g Mode

| Frequency (MHz) | Receiver | | Polar (H/V) | Factor (dB/m) | Result (dB μ V/m) | Limit (dB μ V/m) | Margin (dB) |
|--------------------------|----------------------|----------|-------------|---------------|-----------------------|----------------------|-------------|
| | Reading (dB μ V) | Detector | | | | | |
| Low Channel: 2412 MHz | | | | | | | |
| 2390.000 | 27.85 | PK | H | 31.71 | 59.56 | 74.00 | 14.44 |
| 2390.000 | 14.36 | AV | H | 31.71 | 46.07 | 54.00 | 7.93 |
| 2390.000 | 27.11 | PK | V | 31.71 | 58.82 | 74.00 | 15.18 |
| 2390.000 | 13.82 | AV | V | 31.71 | 45.53 | 54.00 | 8.47 |
| 4824.000 | 37.36 | PK | H | 11.26 | 48.62 | 74.00 | 25.38 |
| 4824.000 | 24.55 | AV | H | 11.26 | 35.81 | 54.00 | 18.19 |
| 4824.000 | 36.25 | PK | V | 11.26 | 47.51 | 74.00 | 26.49 |
| 4824.000 | 23.47 | AV | V | 11.26 | 34.73 | 54.00 | 19.27 |
| 7236.000 | 45.66 | PK | H | 15.24 | 60.90 | 74.00 | 13.10 |
| 7236.000 | 27.06 | AV | H | 15.24 | 42.30 | 54.00 | 11.70 |
| 7236.000 | 43.65 | PK | V | 15.24 | 58.89 | 74.00 | 15.11 |
| 7236.000 | 25.77 | AV | V | 15.24 | 41.01 | 54.00 | 12.99 |
| Middle Channel: 2437 MHz | | | | | | | |
| 4874.000 | 36.92 | PK | H | 11.45 | 48.37 | 74.00 | 25.63 |
| 4874.000 | 24.20 | AV | H | 11.45 | 35.65 | 54.00 | 18.35 |
| 4874.000 | 35.14 | PK | V | 11.45 | 46.59 | 74.00 | 27.41 |
| 4874.000 | 22.36 | AV | V | 11.45 | 33.81 | 54.00 | 20.19 |
| 7311.000 | 45.68 | PK | H | 15.58 | 61.26 | 74.00 | 12.74 |
| 7311.000 | 28.43 | AV | H | 15.58 | 44.01 | 54.00 | 9.99 |
| 7311.000 | 43.52 | PK | V | 15.58 | 59.10 | 74.00 | 14.90 |
| 7311.000 | 25.49 | AV | V | 15.58 | 41.07 | 54.00 | 12.93 |
| High Channel: 2462 MHz | | | | | | | |
| 2483.500 | 28.79 | PK | H | 32.19 | 60.98 | 74.00 | 13.02 |
| 2483.500 | 16.39 | AV | H | 32.19 | 48.58 | 54.00 | 5.42 |
| 2483.500 | 27.64 | PK | V | 32.19 | 59.83 | 74.00 | 14.17 |
| 2483.500 | 15.33 | AV | V | 32.19 | 47.52 | 54.00 | 6.48 |
| 4924.000 | 37.11 | PK | H | 11.67 | 48.78 | 74.00 | 25.22 |
| 4924.000 | 24.20 | AV | H | 11.67 | 35.87 | 54.00 | 18.13 |
| 4924.000 | 36.82 | PK | V | 11.67 | 48.49 | 74.00 | 25.51 |
| 4924.000 | 23.16 | AV | V | 11.67 | 34.83 | 54.00 | 19.17 |
| 7386.000 | 45.36 | PK | H | 15.63 | 60.99 | 74.00 | 13.01 |
| 7386.000 | 27.11 | AV | H | 15.63 | 42.74 | 54.00 | 11.26 |
| 7386.000 | 44.08 | PK | V | 15.63 | 59.71 | 74.00 | 14.29 |
| 7386.000 | 26.39 | AV | V | 15.63 | 42.02 | 54.00 | 11.98 |

802.11n ht20 Mode:

| Frequency (MHz) | Receiver | | Polar (H/V) | Factor (dB/m) | Result (dB μ V/m) | Limit (dB μ V/m) | Margin (dB) |
|--------------------------|----------------------|----------|-------------|---------------|-----------------------|----------------------|-------------|
| | Reading (dB μ V) | Detector | | | | | |
| Low Channel: 2412 MHz | | | | | | | |
| 2390.000 | 27.65 | PK | H | 31.71 | 59.36 | 74.00 | 14.64 |
| 2390.000 | 14.62 | AV | H | 31.71 | 46.33 | 54.00 | 7.67 |
| 2390.000 | 26.92 | PK | V | 31.71 | 58.63 | 74.00 | 15.37 |
| 2390.000 | 14.30 | AV | V | 31.71 | 46.01 | 54.00 | 7.99 |
| 4824.000 | 35.69 | PK | H | 11.26 | 46.95 | 74.00 | 27.05 |
| 4824.000 | 22.87 | AV | H | 11.26 | 34.13 | 54.00 | 19.87 |
| 4824.000 | 34.92 | PK | V | 11.26 | 46.18 | 74.00 | 27.82 |
| 4824.000 | 21.64 | AV | V | 11.26 | 32.90 | 54.00 | 21.10 |
| 7236.000 | 44.63 | PK | H | 15.24 | 59.87 | 74.00 | 14.13 |
| 7236.000 | 26.52 | AV | H | 15.24 | 41.76 | 54.00 | 12.24 |
| 7236.000 | 42.58 | PK | V | 15.24 | 57.82 | 74.00 | 16.18 |
| 7236.000 | 25.11 | AV | V | 15.24 | 40.35 | 54.00 | 13.65 |
| Middle Channel: 2437 MHz | | | | | | | |
| 4874.000 | 35.23 | PK | H | 11.45 | 46.68 | 74.00 | 27.32 |
| 4874.000 | 22.41 | AV | H | 11.45 | 33.86 | 54.00 | 20.14 |
| 4874.000 | 35.20 | PK | V | 11.45 | 46.65 | 74.00 | 27.35 |
| 4874.000 | 21.78 | AV | V | 11.45 | 33.23 | 54.00 | 20.77 |
| 7311.000 | 44.11 | PK | H | 15.58 | 59.69 | 74.00 | 14.31 |
| 7311.000 | 26.55 | AV | H | 15.58 | 42.13 | 54.00 | 11.87 |
| 7311.000 | 43.23 | PK | V | 15.58 | 58.81 | 74.00 | 15.19 |
| 7311.000 | 25.20 | AV | V | 15.58 | 40.78 | 54.00 | 13.22 |
| High Channel: 2462 MHz | | | | | | | |
| 2483.500 | 28.66 | PK | H | 32.19 | 60.85 | 74.00 | 13.15 |
| 2483.500 | 16.69 | AV | H | 32.19 | 48.88 | 54.00 | 5.12 |
| 2483.500 | 27.49 | PK | V | 32.19 | 59.68 | 74.00 | 14.32 |
| 2483.500 | 15.47 | AV | V | 32.19 | 47.66 | 54.00 | 6.34 |
| 4924.000 | 35.23 | PK | H | 11.67 | 46.90 | 74.00 | 27.10 |
| 4924.000 | 22.12 | AV | H | 11.67 | 33.79 | 54.00 | 20.21 |
| 4924.000 | 34.82 | PK | V | 11.67 | 46.49 | 74.00 | 27.51 |
| 4924.000 | 21.69 | AV | V | 11.67 | 33.36 | 54.00 | 20.64 |
| 7386.000 | 43.66 | PK | H | 15.63 | 59.29 | 74.00 | 14.71 |
| 7386.000 | 25.63 | AV | H | 15.63 | 41.26 | 54.00 | 12.74 |
| 7386.000 | 42.69 | PK | V | 15.63 | 58.32 | 74.00 | 15.68 |
| 7386.000 | 25.10 | AV | V | 15.63 | 40.73 | 54.00 | 13.27 |

802.11n ht40 Mode:

| Frequency (MHz) | Receiver | | Polar (H/V) | Factor (dB/m) | Result (dB μ V/m) | Limit (dB μ V/m) | Margin (dB) |
|--------------------------|----------------------|----------|-------------|---------------|-----------------------|----------------------|-------------|
| | Reading (dB μ V) | Detector | | | | | |
| Low Channel: 2422 MHz | | | | | | | |
| 2390.000 | 29.77 | PK | H | 31.71 | 61.48 | 74.00 | 12.52 |
| 2390.000 | 16.74 | AV | H | 31.71 | 48.45 | 54.00 | 5.55 |
| 2390.000 | 28.67 | PK | V | 31.71 | 60.38 | 74.00 | 13.62 |
| 2390.000 | 15.44 | AV | V | 31.71 | 47.15 | 54.00 | 6.85 |
| 4844.000 | 36.20 | PK | H | 11.31 | 47.51 | 74.00 | 26.49 |
| 4844.000 | 23.41 | AV | H | 11.31 | 34.72 | 54.00 | 19.28 |
| 4844.000 | 35.47 | PK | V | 11.31 | 46.78 | 74.00 | 27.22 |
| 4844.000 | 22.16 | AV | V | 11.31 | 33.47 | 54.00 | 20.53 |
| 7266.000 | 44.69 | PK | H | 15.43 | 60.12 | 74.00 | 13.88 |
| 7266.000 | 27.23 | AV | H | 15.43 | 42.66 | 54.00 | 11.34 |
| 7266.000 | 42.88 | PK | V | 15.43 | 58.31 | 74.00 | 15.69 |
| 7266.000 | 25.72 | AV | V | 15.43 | 41.15 | 54.00 | 12.85 |
| Middle Channel: 2437 MHz | | | | | | | |
| 4874.000 | 35.88 | PK | H | 11.45 | 47.33 | 74.00 | 26.67 |
| 4874.000 | 22.63 | AV | H | 11.45 | 34.08 | 54.00 | 19.92 |
| 4874.000 | 35.10 | PK | V | 11.45 | 46.55 | 74.00 | 27.45 |
| 4874.000 | 22.13 | AV | V | 11.45 | 33.58 | 54.00 | 20.42 |
| 7311.000 | 44.71 | PK | H | 15.58 | 60.29 | 74.00 | 13.71 |
| 7311.000 | 26.52 | AV | H | 15.58 | 42.10 | 54.00 | 11.90 |
| 7311.000 | 43.29 | PK | V | 15.58 | 58.87 | 74.00 | 15.13 |
| 7311.000 | 25.30 | AV | V | 15.58 | 40.88 | 54.00 | 13.12 |
| High Channel: 2452 MHz | | | | | | | |
| 2483.500 | 34.15 | PK | H | 32.19 | 66.34 | 74.00 | 7.66 |
| 2483.500 | 18.36 | AV | H | 32.19 | 50.55 | 54.00 | 3.45 |
| 2483.500 | 32.87 | PK | V | 32.19 | 65.06 | 74.00 | 8.94 |
| 2483.500 | 17.32 | AV | V | 32.19 | 49.51 | 54.00 | 4.49 |
| 4904.000 | 36.36 | PK | H | 11.58 | 47.94 | 74.00 | 26.06 |
| 4904.000 | 23.09 | AV | H | 11.58 | 34.67 | 54.00 | 19.33 |
| 4904.000 | 35.13 | PK | V | 11.58 | 46.71 | 74.00 | 27.29 |
| 4904.000 | 22.17 | AV | V | 11.58 | 33.75 | 54.00 | 20.25 |
| 7356.000 | 44.83 | PK | H | 15.55 | 60.38 | 74.00 | 13.62 |
| 7356.000 | 25.47 | AV | H | 15.55 | 41.02 | 54.00 | 12.98 |
| 7356.000 | 43.23 | PK | V | 15.55 | 58.78 | 74.00 | 15.22 |
| 7356.000 | 24.20 | AV | V | 15.55 | 39.75 | 54.00 | 14.25 |

Worst Radiation Spurious Emissions Margin Test plots (802.11b High Channel):

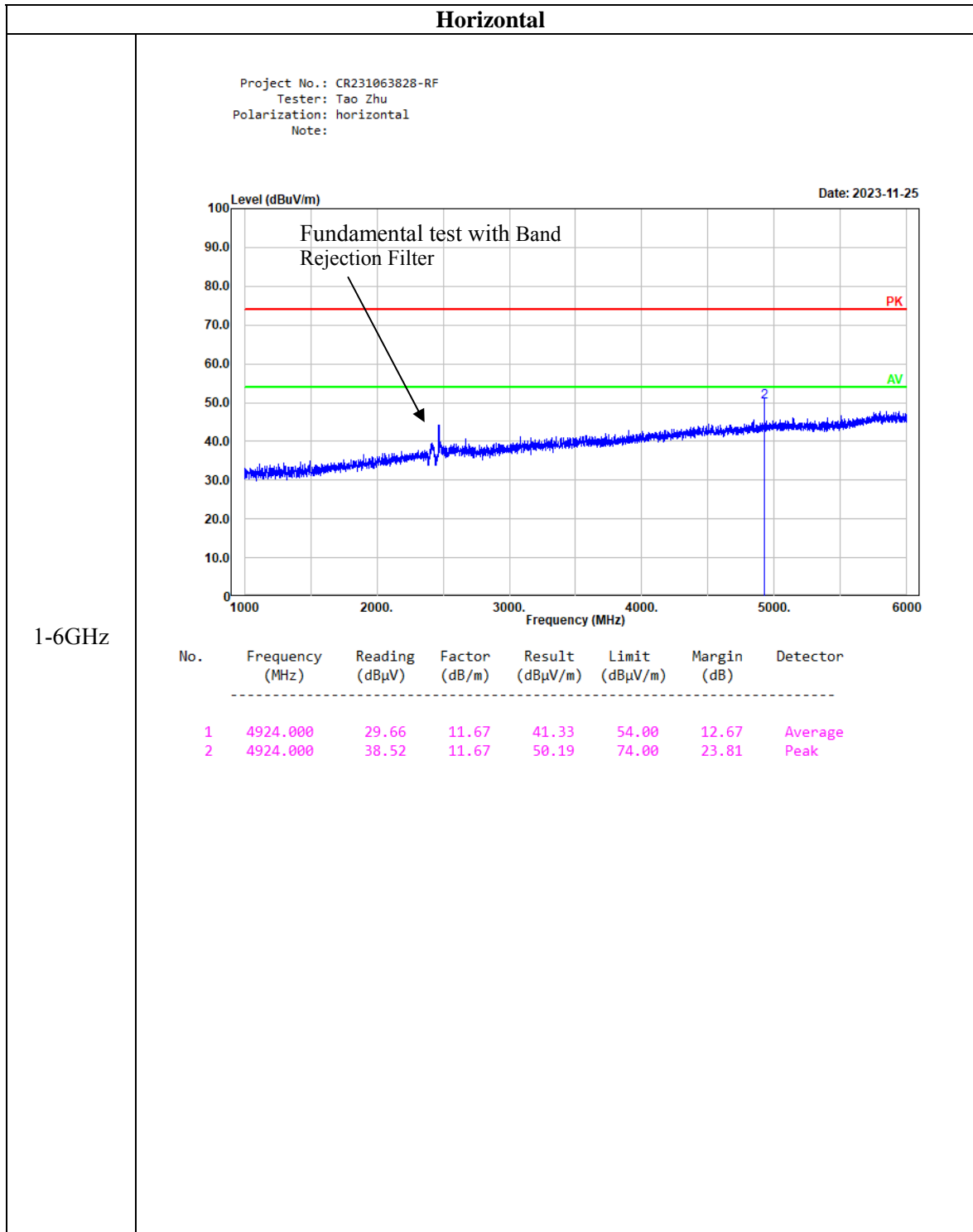

Horizontal

Project No.: CR231063828-RF
 Tester: Tao Zhu
 Polarization: horizontal
 Note:

Date: 2023-11-25

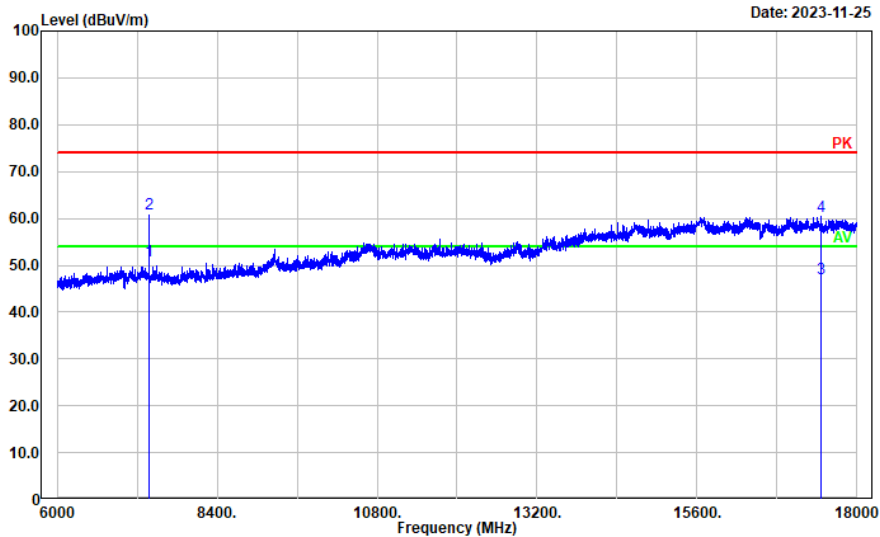

6-18GHz

| No. | Frequency (MHz) | Reading (dBμV) | Factor (dB/m) | Result (dBμV/m) | Limit (dBμV/m) | Margin (dB) | Detector |
|-----|-----------------|----------------|---------------|-----------------|----------------|-------------|----------|
| 1 | 7386.000 | 35.36 | 15.63 | 50.99 | 54.00 | 3.01 | Average |
| 2 | 7386.000 | 45.36 | 15.63 | 60.99 | 74.00 | 13.01 | Peak |
| 3 | 17455.090 | 17.44 | 29.84 | 47.28 | 54.00 | 6.72 | Average |
| 4 | 17455.090 | 30.64 | 29.84 | 60.48 | 74.00 | 13.52 | Peak |

Horizontal

Project No.: CR231063828-RF
 Tester: Tao Zhu
 Polarization: Horizontal
 Note:

Date: 2023-11-25

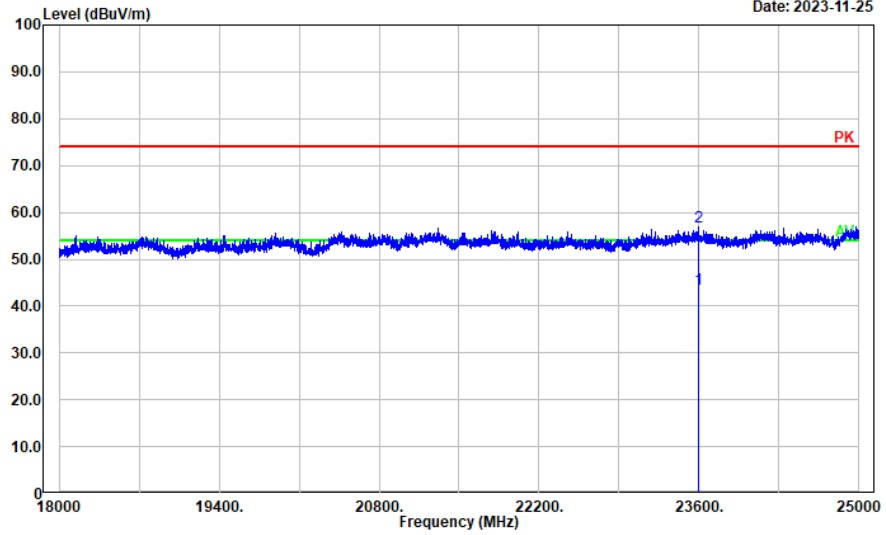

18-25GHz

| No. | Frequency (MHz) | Reading (dBμV) | Factor (dB/m) | Result (dBμV/m) | Limit (dBμV/m) | Margin (dB) | Detector |
|-----|-----------------|----------------|---------------|-----------------|----------------|-------------|----------|
| 1 | 23591.320 | 38.52 | 5.09 | 43.61 | 54.00 | 10.39 | Average |
| 2 | 23591.320 | 51.86 | 5.09 | 56.95 | 74.00 | 17.05 | Peak |

Vertical

Project No.: CR231063828-RF
 Tester: Tao Zhu
 Polarization: Vertical
 Note:

Date: 2023-11-25

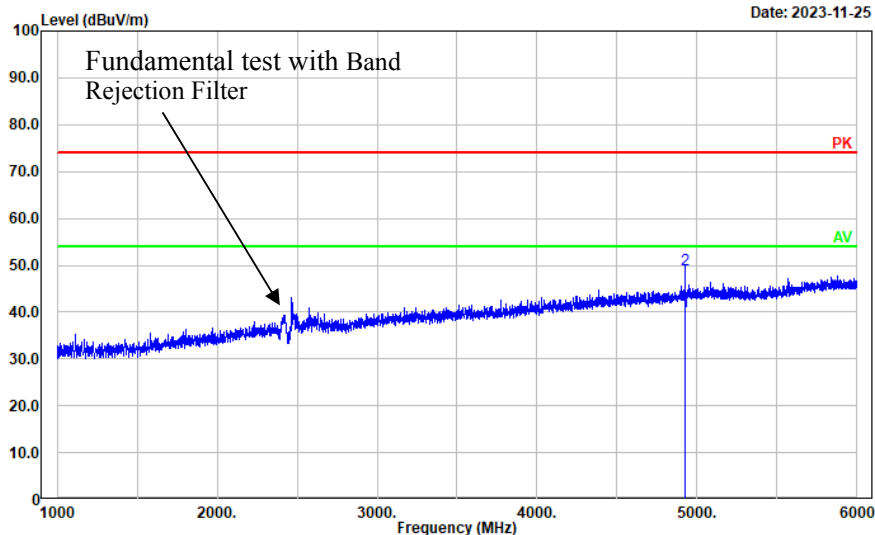

1-6GHz

| No. | Frequency (MHz) | Reading (dBμV) | Factor (dB/m) | Result (dBμV/m) | Limit (dBμV/m) | Margin (dB) | Detector |
|-----|-----------------|----------------|---------------|-----------------|----------------|-------------|----------|
| 1 | 4924.000 | 28.42 | 11.67 | 40.09 | 54.00 | 13.91 | Average |
| 2 | 4924.000 | 37.41 | 11.67 | 49.08 | 74.00 | 24.92 | Peak |

Vertical

Project No.: CR231063828-RF
 Tester: Tao Zhu
 Polarization: Vertical
 Note:

Date: 2023-11-25

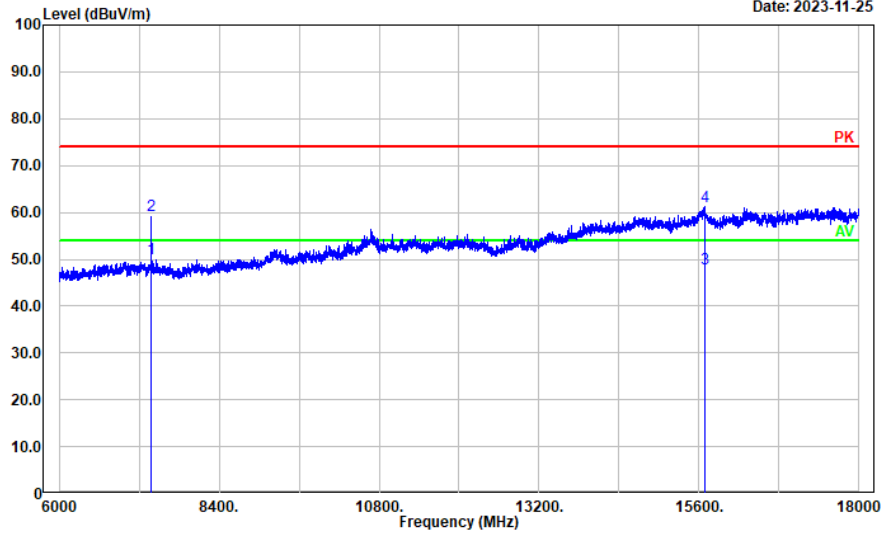

6-18GHz

| No. | Frequency (MHz) | Reading (dBμV) | Factor (dB/m) | Result (dBμV/m) | Limit (dBμV/m) | Margin (dB) | Detector |
|-----|-----------------|----------------|---------------|-----------------|----------------|-------------|----------|
| 1 | 7386.000 | 34.62 | 15.63 | 50.25 | 54.00 | 3.75 | Average |
| 2 | 7386.000 | 43.78 | 15.63 | 59.41 | 74.00 | 14.59 | Peak |
| 3 | 15678.740 | 23.12 | 24.77 | 47.89 | 54.00 | 6.11 | Average |
| 4 | 15678.740 | 36.43 | 24.77 | 61.20 | 74.00 | 12.80 | Peak |

Vertical

Project No.: CR231063828-RF
 Tester: Tao Zhu
 Polarization: Vertical
 Note:

Date: 2023-11-25

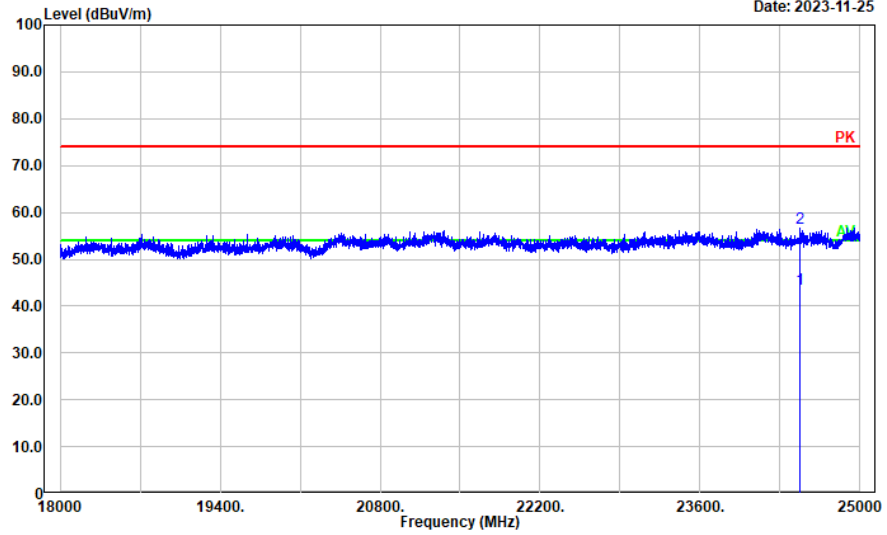

18-25GHz

| No. | Frequency (MHz) | Reading (dBμV) | Factor (dB/m) | Result (dBμV/m) | Limit (dBμV/m) | Margin (dB) | Detector |
|-----|-----------------|----------------|---------------|-----------------|----------------|-------------|----------|
| 1 | 24477.700 | 38.25 | 5.33 | 43.58 | 54.00 | 10.42 | Average |
| 2 | 24477.700 | 51.43 | 5.33 | 56.76 | 74.00 | 17.24 | Peak |

4.3 Minimum 6 dB Emission Bandwidth

| | | | |
|----------------|------------|--------------|--------------|
| Serial Number: | 2CX3-2 | Test Date: | 2023/11/7 |
| Test Site: | RF | Test Mode: | Transmitting |
| Tester: | Claire Liu | Test Result: | Pass |

Environmental Conditions:

| | | | | | |
|----------------------|------|---------------------------|----|------------------------|-----|
| Temperature: (°C) | 24.9 | Relative Humidity: (%) | 58 | ATM Pressure: (kPa) | 101 |
|----------------------|------|---------------------------|----|------------------------|-----|

Test Equipment List and Details:

| Manufacturer | Description | Model | Serial Number | Calibration Date | Calibration Due Date |
|--------------|-------------------|---------|---------------|------------------|----------------------|
| R&S | Spectrum Analyzer | FSU26 | 200256 | 2023/3/31 | 2024/3/30 |
| zhuoxiang | Coaxial Cable | SMA-178 | 211001 | Each time | N/A |

* Statement of Traceability: China Certification ICT Co., Ltd (Dongguan) attests that all calibrations have been performed, traceable to National Primary Standards and International System of Units (SI).

Test Data:

| Test Modes | Test Frequency (MHz) | 6 dB Bandwidth (MHz) | Limit (MHz) |
|--------------|----------------------|----------------------|-------------|
| 802.11b | 2412 | 12.56 | 0.5 |
| | 2437 | 12.16 | 0.5 |
| | 2462 | 12.08 | 0.5 |
| 802.11g | 2412 | 15.20 | 0.5 |
| | 2437 | 15.20 | 0.5 |
| | 2462 | 15.44 | 0.5 |
| 802.11n ht20 | 2412 | 15.12 | 0.5 |
| | 2437 | 15.04 | 0.5 |
| | 2462 | 14.96 | 0.5 |
| 802.11n ht40 | 2422 | 33.92 | 0.5 |
| | 2437 | 34.88 | 0.5 |
| | 2452 | 35.04 | 0.5 |

6dB Emission Bandwidth

802.11b
Lowest Channel

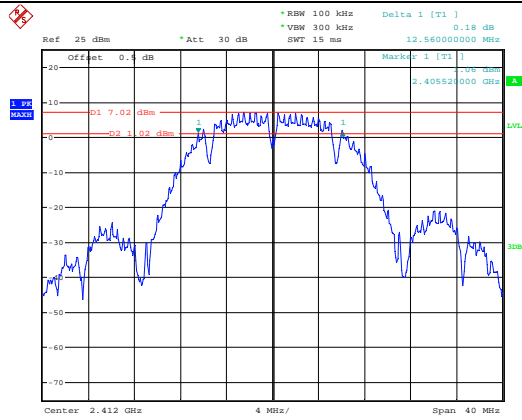

ProjectNo.:CR231063828-RF Tester: Claire Liu

Date: 7.NOV.2023 09:15:21

802.11b
Middle Channel

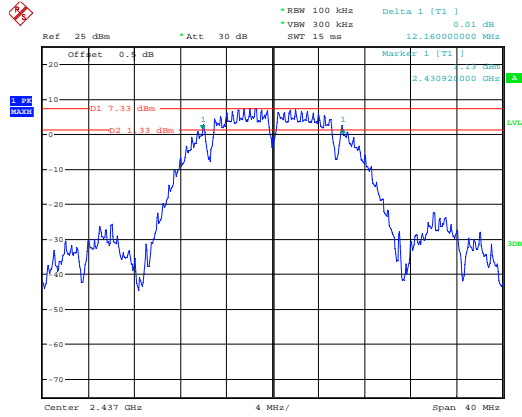

ProjectNo.:CR231063828-RF Tester: Claire Liu

Date: 7.NOV.2023 09:21:16

802.11b
Highest Channel

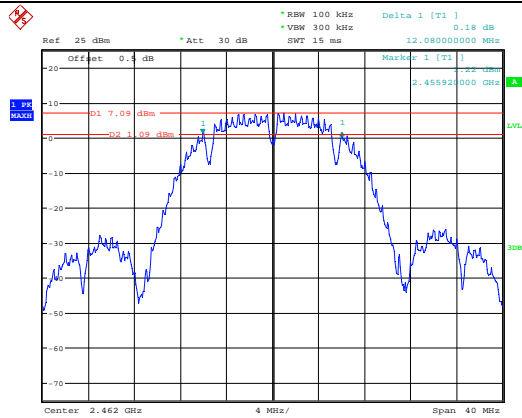

ProjectNo.:CR231063828-RF Tester: Claire Liu

Date: 7.NOV.2023 09:26:21

6dB Emission Bandwidth

802.11g
Lowest Channel

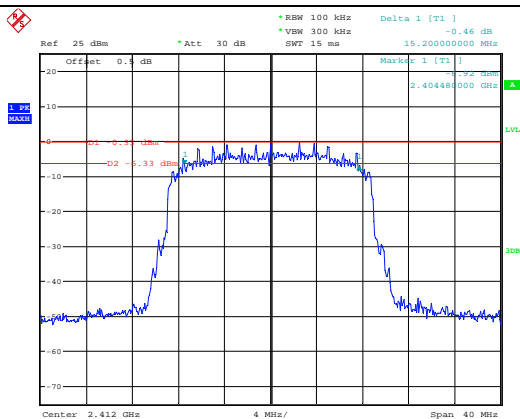

ProjectNo.:CR231063828-RF Tester: Claire Liu
Date: 7.NOV.2023 09:12:08

802.11g
Middle Channel

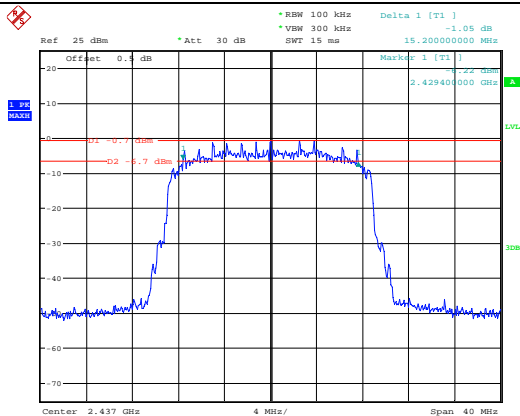

ProjectNo.:CR231063828-RF Tester: Claire Liu
Date: 7.NOV.2023 09:10:06

802.11g
Highest Channel

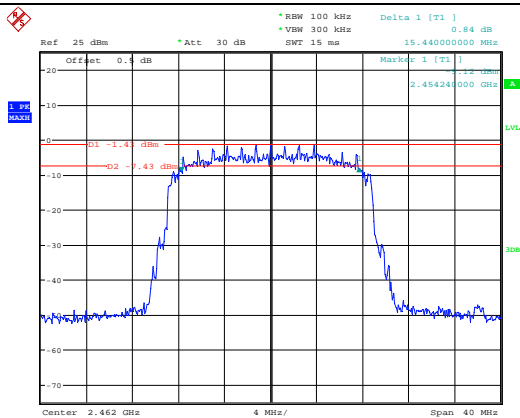

ProjectNo.:CR231063828-RF Tester: Claire Liu
Date: 7.NOV.2023 09:07:40

| 6dB Emission Bandwidth | |
|---|---|
| <p>802.11n ht20 Lowest Channel</p> | <p>ProjectNo.:CR231063828-RF Tester: Claire Liu Date: 7.NOV.2023 08:57:11</p> |
| <p>802.11n ht20 Middle Channel</p> | <p>ProjectNo.:CR231063828-RF Tester: Claire Liu Date: 7.NOV.2023 09:02:10</p> |
| <p>802.11n ht20 Highest Channel</p> | <p>ProjectNo.:CR231063828-RF Tester: Claire Liu Date: 7.NOV.2023 09:05:46</p> |

| 6dB Emission Bandwidth | |
|---------------------------------|---|
| 802.11n ht40 Lowest Channel | <p>ProjectNo.:CR231063828-RF Tester: Claire Liu Date: 7.NOV.2023 08:54:53</p> |
| 802.11n ht40 Middle Channel | <p>ProjectNo.:CR231063828-RF Tester: Claire Liu Date: 7.NOV.2023 08:48:50</p> |
| 802.11n ht40 Highest Channel | <p>ProjectNo.:CR231063828-RF Tester: Claire Liu Date: 7.NOV.2023 08:40:27</p> |

4.4 99% Occupied Bandwidth

| | | | |
|----------------|------------|--------------|--------------|
| Serial Number: | 2CX3-2 | Test Date: | 2023/11/7 |
| Test Site: | RF | Test Mode: | Transmitting |
| Tester: | Claire Liu | Test Result: | N/A |

Environmental Conditions:

| | | | | | |
|----------------------|------|---------------------------|----|------------------------|-----|
| Temperature: (°C) | 24.9 | Relative Humidity: (%) | 58 | ATM Pressure: (kPa) | 101 |
|----------------------|------|---------------------------|----|------------------------|-----|

Test Equipment List and Details:

| Manufacturer | Description | Model | Serial Number | Calibration Date | Calibration Due Date |
|--------------|-------------------|---------|---------------|------------------|----------------------|
| R&S | Spectrum Analyzer | FSU26 | 200256 | 2023/3/31 | 2024/3/30 |
| zhuoxiang | Coaxial Cable | SMA-178 | 211001 | Each time | N/A |

* Statement of Traceability: China Certification ICT Co., Ltd (Dongguan) attests that all calibrations have been performed, traceable to National Primary Standards and International System of Units (SI).

Test Data:

| Test Modes | Test Channel | Test Frequency (MHz) | 99% Occupied Bandwidth (MHz) |
|--------------|--------------|----------------------|------------------------------|
| 802.11b | Lowest | 2412 | 15.76 |
| | Middle | 2437 | 15.52 |
| | Highest | 2462 | 15.28 |
| 802.11g | Lowest | 2412 | 17.28 |
| | Middle | 2437 | 17.04 |
| | Highest | 2462 | 17.36 |
| 802.11n ht20 | Lowest | 2412 | 18.40 |
| | Middle | 2437 | 18.08 |
| | Highest | 2462 | 18.32 |
| 802.11n ht40 | Lowest | 2422 | 35.84 |
| | Middle | 2437 | 35.84 |
| | Highest | 2452 | 35.84 |

99% Occupied Bandwidth

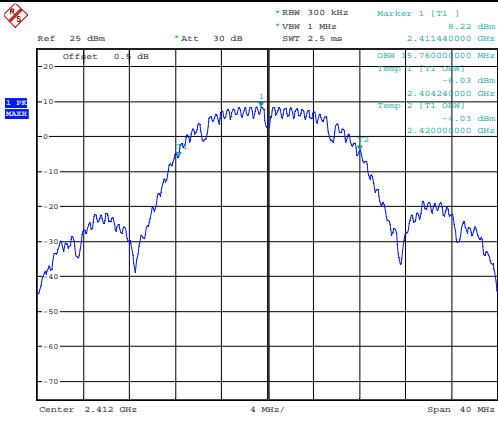
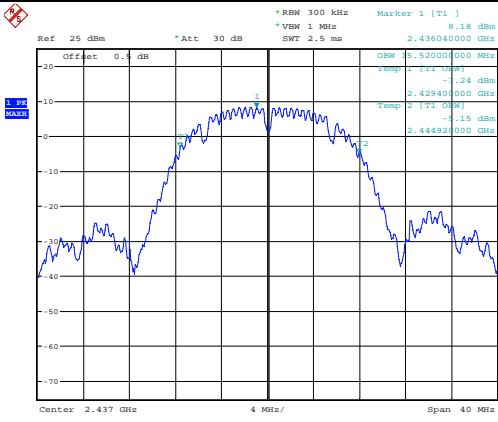
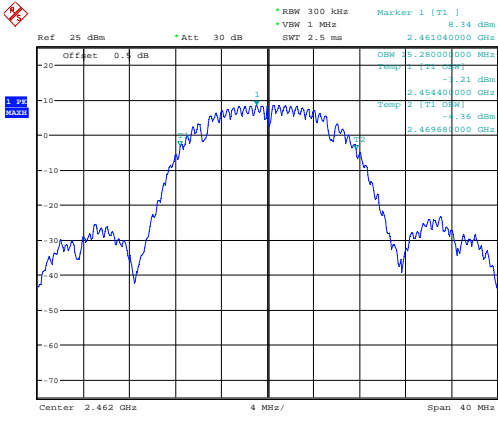
| | |
|------------------------------------|--|
| <p>802.11b Lowest Channel</p> |  <p>ProjectNo.:CR231063828-RF Tester: Claire Liu Date: 7.NOV.2023 09:14:00</p> |
| <p>802.11b Middle Channel</p> |  <p>ProjectNo.:CR231063828-RF Tester: Claire Liu Date: 7.NOV.2023 09:18:47</p> |
| <p>802.11b Highest Channel</p> |  <p>ProjectNo.:CR231063828-RF Tester: Claire Liu Date: 7.NOV.2023 09:23:19</p> |

99% Occupied Bandwidth

| | |
|------------------------------------|---|
| <p>802.11g Lowest Channel</p> | <p>ProjectNo.:CR231063828-RF Tester: Claire Liu Date: 7.NOV.2023 09:12:22</p> |
| <p>802.11g Middle Channel</p> | <p>ProjectNo.:CR231063828-RF Tester: Claire Liu Date: 7.NOV.2023 09:10:23</p> |
| <p>802.11g Highest Channel</p> | <p>ProjectNo.:CR231063828-RF Tester: Claire Liu Date: 7.NOV.2023 09:07:56</p> |

99% Occupied Bandwidth

802.11n ht20
Lowest Channel

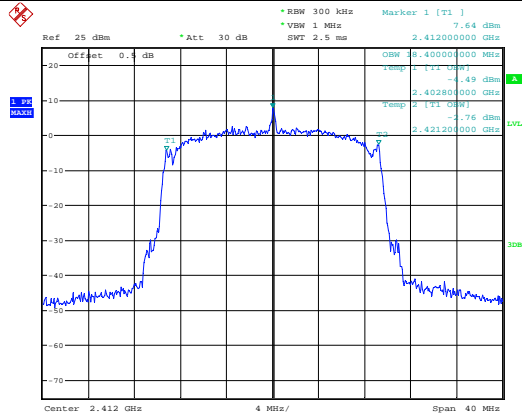

ProjectNo.:CR231063828-RF Tester: Claire Liu
Date: 7.NOV.2023 08:57:28

802.11n ht20
Middle Channel

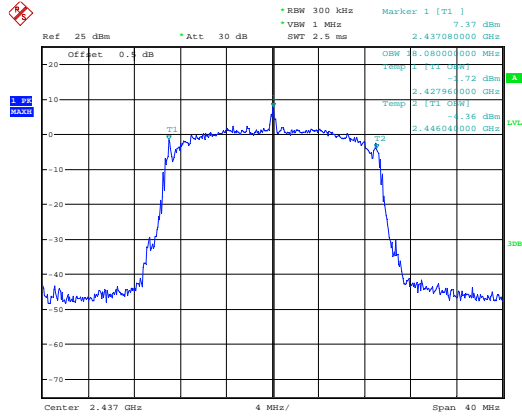

ProjectNo.:CR231063828-RF Tester: Claire Liu
Date: 7.NOV.2023 09:02:27

802.11n ht20
Highest Channel

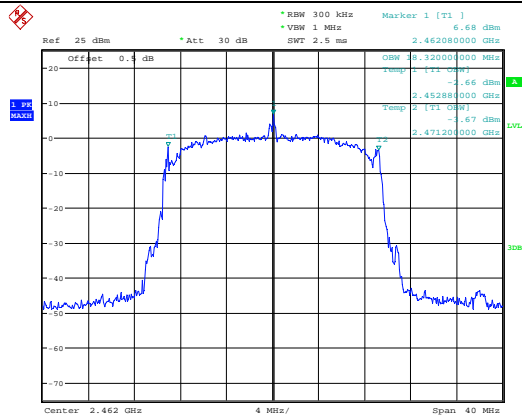

ProjectNo.:CR231063828-RF Tester: Claire Liu
Date: 7.NOV.2023 09:04:18

99% Occupied Bandwidth

802.11n ht40
Lowest Channel

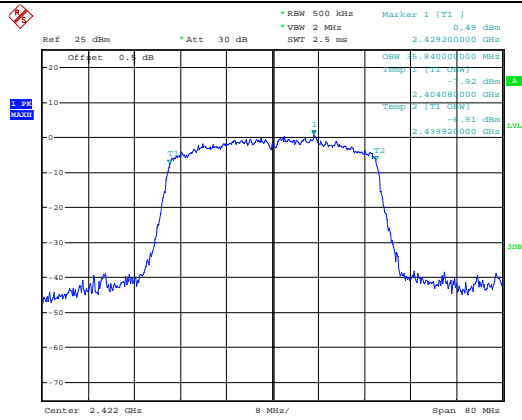

ProjectNo.:CR231063828-RF Tester: Claire Liu
Date: 7.NOV.2023 08:50:56

802.11n ht40
Middle Channel

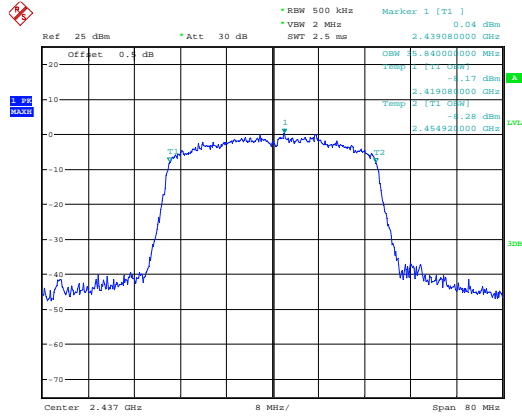

ProjectNo.:CR231063828-RF Tester: Claire Liu
Date: 7.NOV.2023 08:49:03

802.11n ht40
Highest Channel

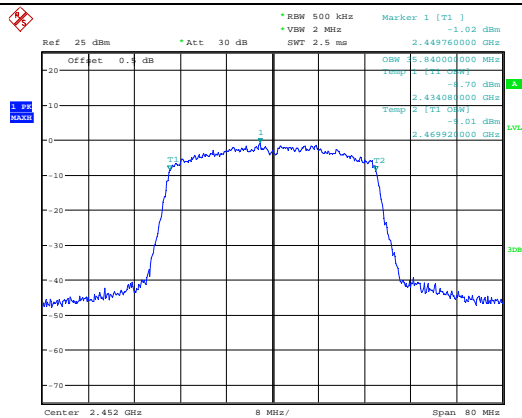

ProjectNo.:CR231063828-RF Tester: Claire Liu
Date: 7.NOV.2023 08:41:59

4.5 Maximum Conducted Output Power

| | | | |
|----------------|------------|--------------|--------------|
| Serial Number: | 2CX3-2 | Test Date: | 2023/11/7 |
| Test Site: | RF | Test Mode: | Transmitting |
| Tester: | Claire Liu | Test Result: | Pass |

Environmental Conditions:

| | | | | | |
|----------------------|------|---------------------------|----|------------------------|-----|
| Temperature: (°C) | 24.9 | Relative Humidity: (%) | 58 | ATM Pressure: (kPa) | 101 |
|----------------------|------|---------------------------|----|------------------------|-----|

Test Equipment List and Details:

| Manufacturer | Description | Model | Serial Number | Calibration Date | Calibration Due Date |
|--------------|--------------------|---------------|---------------|------------------|----------------------|
| zhuoxiang | Coaxial Cable | SMA-178 | 211001 | Each time | N/A |
| Anritsu | Power Meter | ML2495A | 1106009 | 2023/8/4 | 2024/8/3 |
| Anritsu | Pulse Power Sensor | MA2411A | 10780 | 2023/8/4 | 2024/8/3 |
| eastsheep | Coaxial Attenuator | 2W-SMA-JK-18G | 21060301 | Each time | N/A |

* Statement of Traceability: China Certification ICT Co., Ltd (Dongguan) attests that all calibrations have been performed, traceable to National Primary Standards and International System of Units (SI).

Test Data:

| Test Modes | Test Frequency (MHz) | Maximum Conducted Peak Output Power (dBm) | Limit (dBm) |
|--------------|----------------------|---|-------------|
| 802.11b | 2412 | 21.31 | 30 |
| | 2437 | 21.71 | 30 |
| | 2462 | 21.48 | 30 |
| 802.11g | 2412 | 19.89 | 30 |
| | 2437 | 19.74 | 30 |
| | 2462 | 19.69 | 30 |
| 802.11n ht20 | 2412 | 19.97 | 30 |
| | 2437 | 19.72 | 30 |
| | 2462 | 19.34 | 30 |
| 802.11n ht40 | 2422 | 19.91 | 30 |
| | 2437 | 19.78 | 30 |
| | 2452 | 19.49 | 30 |

4.6 Maximum Power Spectral Density

| | | | |
|----------------|------------|--------------|--------------|
| Serial Number: | 2CX3-2 | Test Date: | 2023/11/7 |
| Test Site: | RF | Test Mode: | Transmitting |
| Tester: | Claire Liu | Test Result: | Pass |

Environmental Conditions:

| | | | | | |
|----------------------|------|---------------------------|----|------------------------|-----|
| Temperature: (°C) | 24.9 | Relative Humidity: (%) | 58 | ATM Pressure: (kPa) | 101 |
|----------------------|------|---------------------------|----|------------------------|-----|

Test Equipment List and Details:

| Manufacturer | Description | Model | Serial Number | Calibration Date | Calibration Due Date |
|--------------|-------------------|---------|---------------|------------------|----------------------|
| R&S | Spectrum Analyzer | FSU26 | 200256 | 2023/3/31 | 2024/3/30 |
| zhuoxiang | Coaxial Cable | SMA-178 | 211001 | Each time | N/A |

* Statement of Traceability: China Certification ICT Co., Ltd (Dongguan) attests that all calibrations have been performed, traceable to National Primary Standards and International System of Units (SI).

Test Data:

| Test Modes | Test Frequency (MHz) | Power Spectral Density (dBm/3kHz) | Limit (dBm/3kHz) |
|--------------|----------------------|-----------------------------------|------------------|
| 802.11b | 2412 | -6.75 | 8.00 |
| | 2437 | -6.73 | 8.00 |
| | 2462 | -6.32 | 8.00 |
| 802.11g | 2412 | -7.95 | 8.00 |
| | 2437 | -8.17 | 8.00 |
| | 2462 | -8.02 | 8.00 |
| 802.11n ht20 | 2412 | -7.39 | 8.00 |
| | 2437 | -7.82 | 8.00 |
| | 2462 | -8.56 | 8.00 |
| 802.11n ht40 | 2422 | -8.68 | 8.00 |
| | 2437 | -8.53 | 8.00 |
| | 2452 | -9.56 | 8.00 |

Maximum Power Spectral Density

802.11b
Lowest Channel

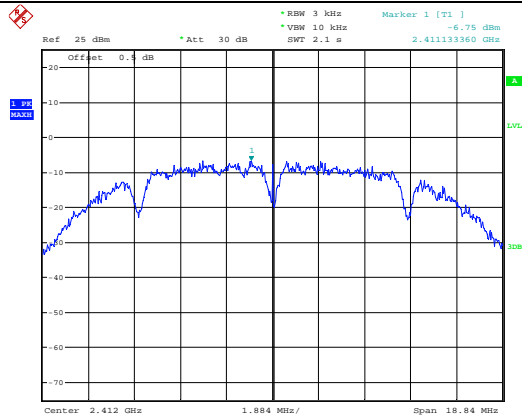

ProjectNo.:CR231063828-RF Tester: Claire Liu
Date: 7.NOV.2023 09:16:02

802.11b
Middle Channel

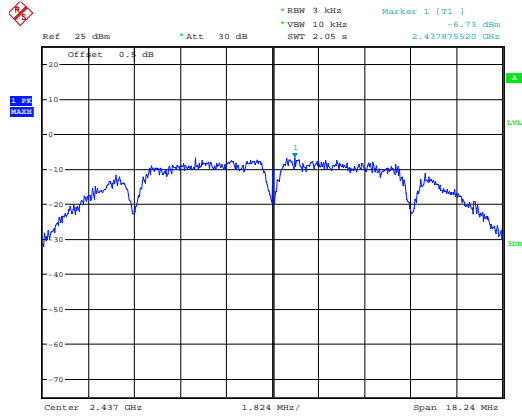

ProjectNo.:CR231063828-RF Tester: Claire Liu
Date: 7.NOV.2023 09:22:05

802.11b
Highest Channel

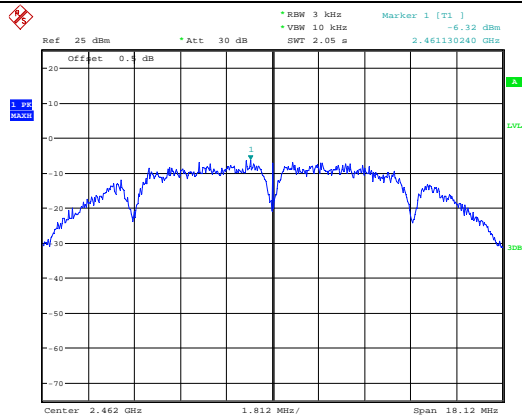

ProjectNo.:CR231063828-RF Tester: Claire Liu
Date: 7.NOV.2023 09:27:05

Maximum Power Spectral Density

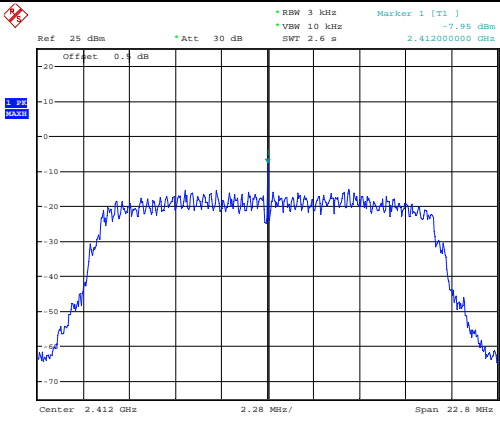
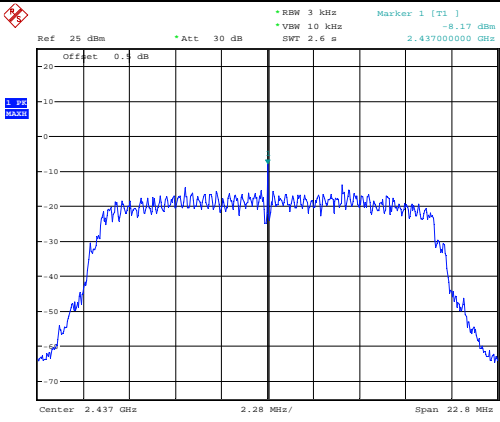
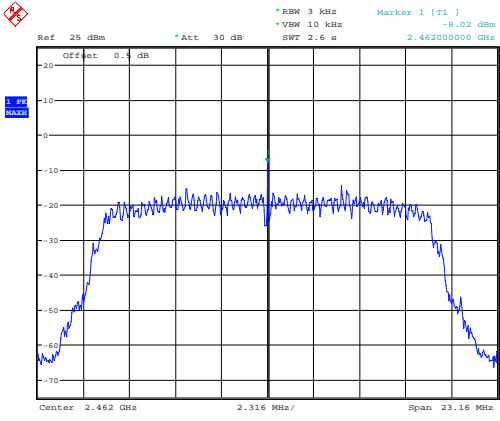
| | |
|------------------------------------|--|
| <p>802.11g Lowest Channel</p> |  <p>ProjectNo.:CR231063828-RF Tester: Claire Liu Date: 7.NOV.2023 09:12:54</p> |
| <p>802.11g Middle Channel</p> |  <p>ProjectNo.:CR231063828-RF Tester: Claire Liu Date: 7.NOV.2023 09:11:04</p> |
| <p>802.11g Highest Channel</p> |  <p>ProjectNo.:CR231063828-RF Tester: Claire Liu Date: 7.NOV.2023 09:08:29</p> |

Maximum Power Spectral Density

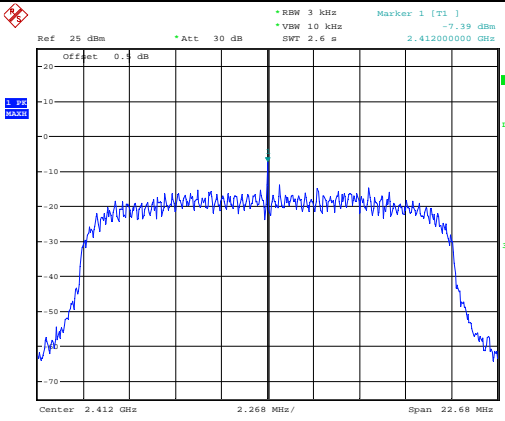
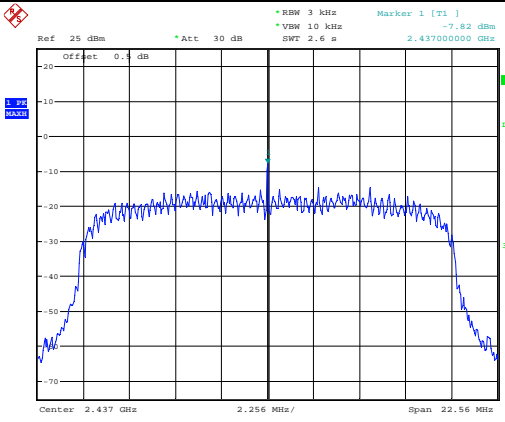
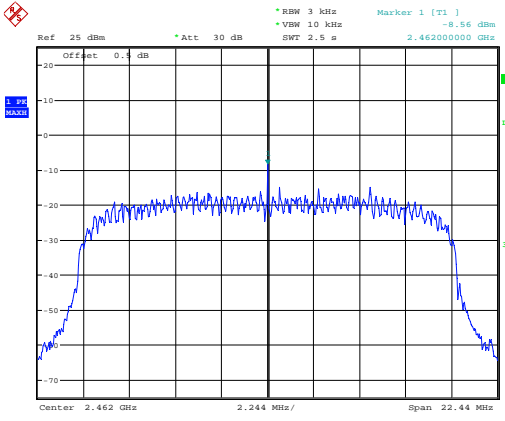
| | |
|---|--|
| <p>802.11n ht20 Lowest Channel</p> |  <p>ProjectNo.:CR231063828-RF Tester: Claire Liu Date: 7.NOV.2023 08:58:00</p> |
| <p>802.11n ht20 Middle Channel</p> |  <p>ProjectNo.:CR231063828-RF Tester: Claire Liu Date: 7.NOV.2023 09:02:51</p> |
| <p>802.11n ht20 Highest Channel</p> |  <p>ProjectNo.:CR231063828-RF Tester: Claire Liu Date: 7.NOV.2023 09:06:27</p> |

Maximum Power Spectral Density

| | |
|---|---|
| <p>802.11n ht40 Lowest Channel</p> | <p>ProjectNo.:CR231063828-RF Tester:Clair Liu Date: 7.NOV.2023 08:55:55</p> |
| <p>802.11n ht40 Middle Channel</p> | <p>ProjectNo.:CR231063828-RF Tester:Clair Liu Date: 7.NOV.2023 08:49:49</p> |
| <p>802.11n ht40 Highest Channel</p> | <p>ProjectNo.:CR231063828-RF Tester:Clair Liu Date: 7.NOV.2023 08:45:06</p> |

4.7 100 kHz Bandwidth of Frequency Band Edge

| | | | |
|----------------|------------|--------------|--------------|
| Serial Number: | 2CX3-2 | Test Date: | 2023/11/7 |
| Test Site: | RF | Test Mode: | Transmitting |
| Tester: | Claire Liu | Test Result: | Pass |

Environmental Conditions:

| | | | | | |
|----------------------|------|---------------------------|----|------------------------|-----|
| Temperature: (°C) | 24.9 | Relative Humidity: (%) | 58 | ATM Pressure: (kPa) | 101 |
|----------------------|------|---------------------------|----|------------------------|-----|

Test Equipment List and Details:

| Manufacturer | Description | Model | Serial Number | Calibration Date | Calibration Due Date |
|--------------|-------------------|---------|---------------|------------------|----------------------|
| R&S | Spectrum Analyzer | FSU26 | 200256 | 2023/3/31 | 2024/3/30 |
| zhuoxiang | Coaxial Cable | SMA-178 | 211001 | Each time | N/A |

* Statement of Traceability: China Certification ICT Co., Ltd (Dongguan) attests that all calibrations have been performed, traceable to National Primary Standards and International System of Units (SI).

Test Data:

100 kHz Bandwidth of Frequency Band Edge

802.11b
Lowest Band edge

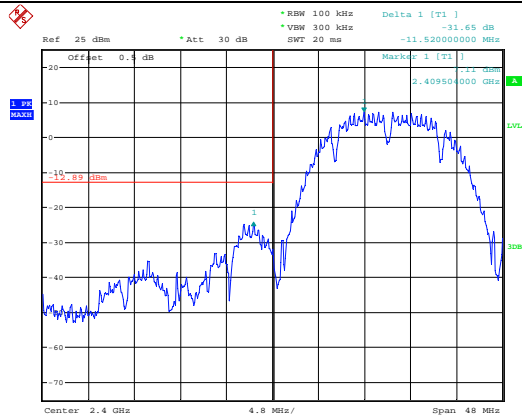

802.11b
Highest Band edge

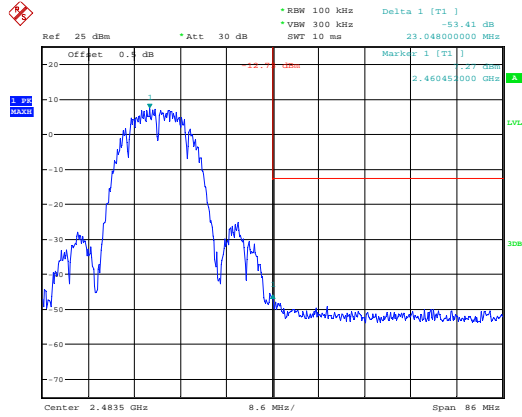

100 kHz Bandwidth of Frequency Band Edge

802.11g
Lowest Band edge

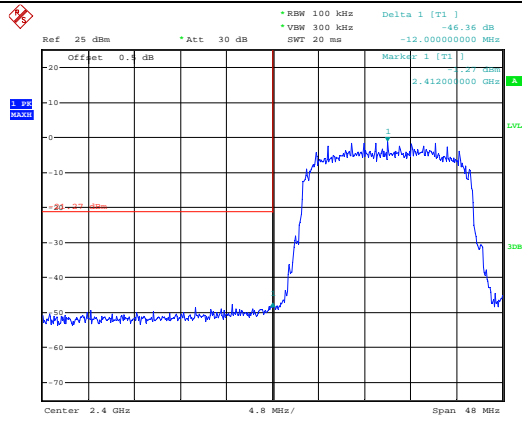

ProjectNo.:CR231063828-RF Tester: Claire Liu
 Date: 7.NOV.2023 09:13:07

802.11g
Highest Band edge

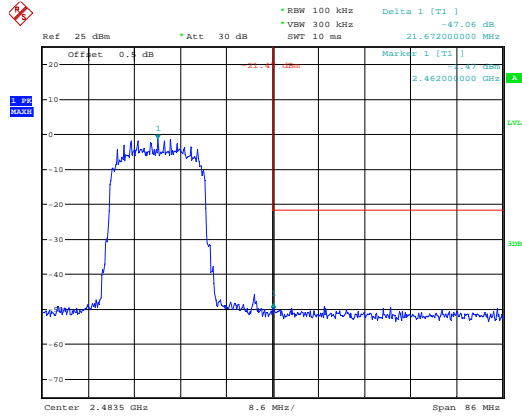

ProjectNo.:CR231063828-RF Tester: Claire Liu
 Date: 7.NOV.2023 09:08:45

100 kHz Bandwidth of Frequency Band Edge

802.11n ht20
Lowest Band edge

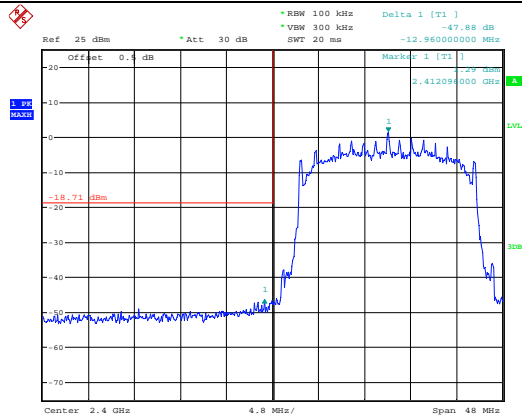

ProjectNo.:CR231063828-RF Tester: Claire Liu
 Date: 7.NOV.2023 08:58:17

802.11n ht20
Highest Band edge

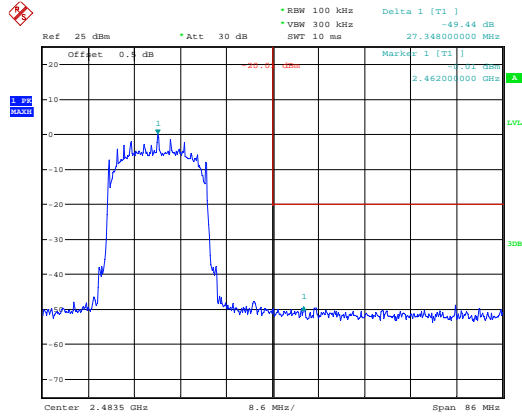

ProjectNo.:CR231063828-RF Tester: Claire Liu
 Date: 7.NOV.2023 09:05:05

100 kHz Bandwidth of Frequency Band Edge

802.11n ht40
Lowest Band edge

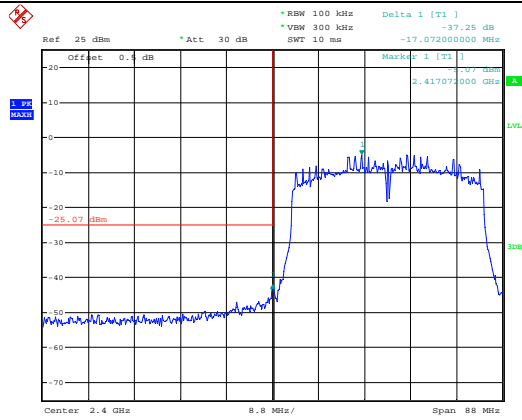

ProjectNo.:CR231063828-RF Tester: Claire Liu
Date: 7.NOV.2023 08:51:54

802.11n ht40
Highest Band edge

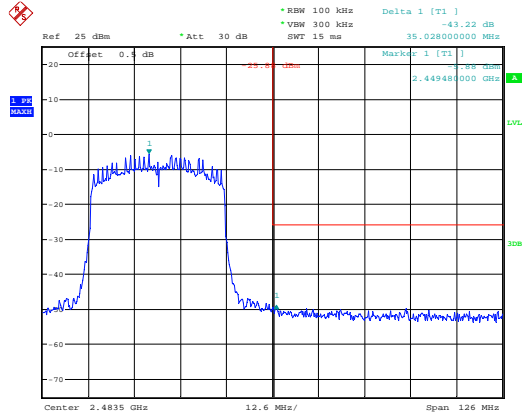

ProjectNo.:CR231063828-RF Tester: Claire Liu
Date: 7.NOV.2023 08:45:20

4.8 Duty Cycle

| | | | |
|----------------|------------|--------------|--------------|
| Serial Number: | 2CX3-2 | Test Date: | 2023/11/7 |
| Test Site: | RF | Test Mode: | Transmitting |
| Tester: | Claire Liu | Test Result: | N/A |

| | | | | | |
|----------------------------------|------|---------------------------|----|------------------------|-----|
| Environmental Conditions: | | | | | |
| Temperature: (°C) | 24.9 | Relative Humidity: (%) | 58 | ATM Pressure: (kPa) | 101 |

Test Equipment List and Details:

| Manufacturer | Description | Model | Serial Number | Calibration Date | Calibration Due Date |
|--------------|-------------------|---------|---------------|------------------|----------------------|
| R&S | Spectrum Analyzer | FSU26 | 200256 | 2023/3/31 | 2024/3/30 |
| zhuoxiang | Coaxial Cable | SMA-178 | 211001 | Each time | N/A |

* Statement of Traceability: China Certification ICT Co., Ltd (Dongguan) attests that all calibrations have been performed, traceable to National Primary Standards and International System of Units (SI).

Test Data:

| Test Modes | Ton (ms) | Ton+off (ms) | Duty cycle (%) | 1/T (Hz) | Duty Factor (dB) | VBW Setting (kHz) |
|--------------|----------|--------------|----------------|----------|------------------|-------------------|
| 802.11b | 100 | 100 | 100.00 | / | / | 0.01 |
| 802.11g | 100 | 100 | 100.00 | / | / | 0.01 |
| 802.11n ht20 | 100 | 100 | 100.00 | / | / | 0.01 |
| 802.11n ht40 | 100 | 100 | 100.00 | / | / | 0.01 |

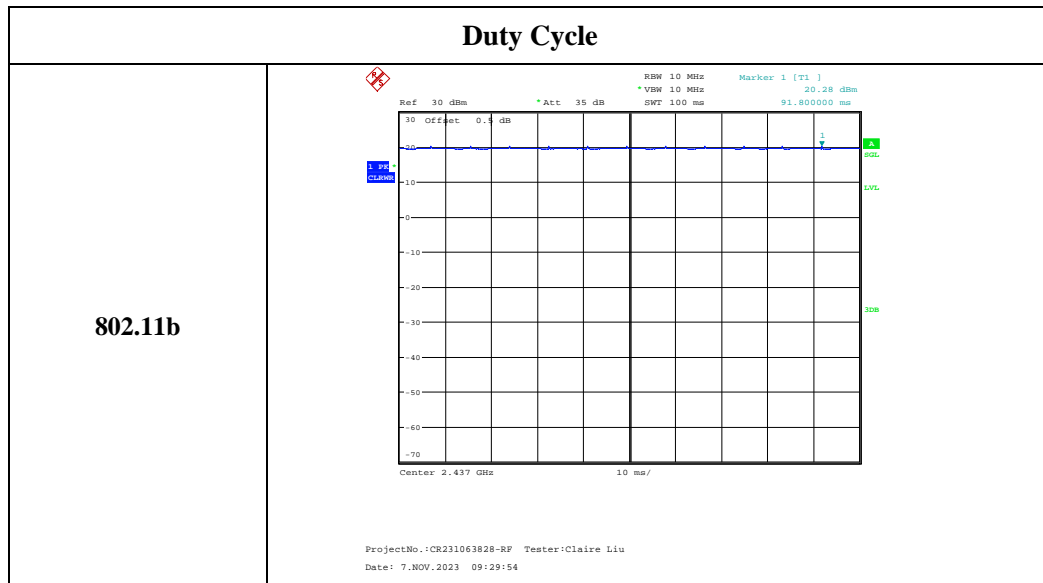

802.11g

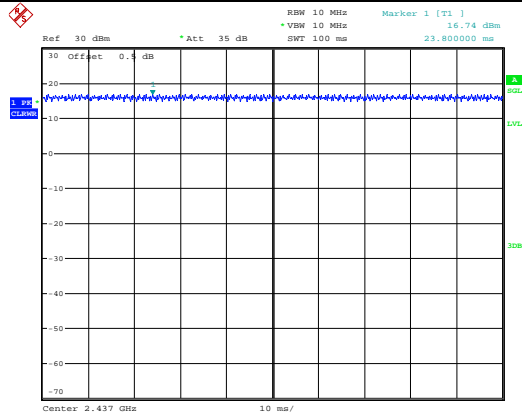

ProjectNo.:CR231063828-RP Tester: Claire Liu
 Date: 7.NOV.2023 09:30:33

802.11n ht20

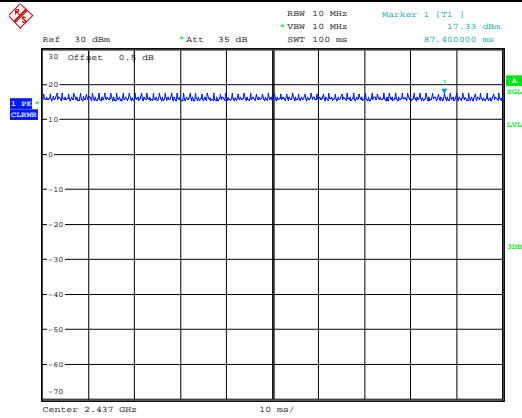

ProjectNo.:CR231063828-RP Tester: Claire Liu
 Date: 7.NOV.2023 09:30:59

802.11n ht40

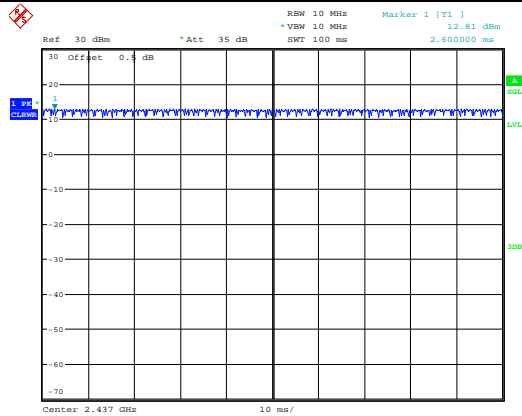

ProjectNo.:CR231063828-RP Tester: Claire Liu
 Date: 7.NOV.2023 09:31:30

5. EUT PHOTOGRAPHS

Please refer to the attachment CR231063828-EXP EUT EXTERNAL PHOTOGRAPHS and CR231063828-INP EUT INTERNAL PHOTOGRAPHS

6. TEST SETUP PHOTOGRAPHS

Please refer to the attachment CR231063828-00B-TSP TEST SETUP PHOTOGRAPHS.

===== END OF REPORT =====