

makeblock

Makeblock Co., Ltd.

Address: 4th Floor, Building C3, Nanshan iPark,
No.1001 Xueyuan Avenue, Nanshan District,
Shenzhen, Guangdong Province, China
www.makeblock.com

D1.2.3_KD010121000

makeblock

laserbox

User Manual

Model:MLN-K503-40W



Statement

Welcome to use Makeblock products!

Before installing and using the product for the first time, please carefully read all the accompanying materials of the product to improve your experience with it. If you fail to use the product according to the instructions and requirements of the Manual, or mis-operate the product due to misunderstanding, etc., Makeblock Co., Ltd. (Shenzhen) will bear no responsibility for any loss resulting therefrom, except for losses due to improper installation or operation by Makeblock professional maintenance personnel.

Makeblock Co., Ltd. (Shenzhen) has collated the Manual rigorously and carefully, but we cannot guarantee that the Manual is completely free of error or omission.

Makeblock Co., Ltd. (Shenzhen) is committed to continuously improving product functionality and service quality, and therefore reserves the right to change any product or software program described in the Manual and the contents of the Manual at any time without prior notice.

The Manual is intended to help you use the product correctly and does not include any description of the product hardware and software configuration. For product configuration, please refer to the relevant contract (if any) and packing list, or consult your distributor. Pictures in the Manual are for reference only and the actual product may vary.

Protected by copyright laws and regulations, the Manual shall not be reproduced or transcribed in any way, or be transmitted on any wired or wireless network in any manner, or be translated into any language without the prior written authorization of Makeblock Co., Ltd. (Shenzhen).

Makeblock service information

Please contact us if you find the actual product is inconsistent with the Manual during operation, or if you want to get the latest information, or have any questions or suggestions.

Technical support: support@makeblock.com

Note: The above information may be subject to change due to objective factors, and please refer to the latest release of Makeblock. If you use the internet or phone call to get our support, additional fees may apply.

Contents

- 01 Safety First (Important)
- 05 List of Items
- 06 Meet Your LaserBox
- 10 Quick Operation Guide
 - Connect the smart smoke purifier
 - Start the LaserBox
 - Connect a computer to the LaserBox
 - Start cutting / engraving
- 23 More Operations
 - Pause the task
 - Cancel the task
 - Clean chippings
- 26 More Features
 - Bring sketch to life
 - Image extraction
- 29 Appendix 1: Cutting/Engraving Material Requirements
- 30 Appendix 2: Annular Indicator Status Description
- 32 Product Warranty Information

Safety First (Important)

1. General safety

Read and get familiar with all safety protocols and procedures before operating the LaserBox. Users shall strictly follow all safety precautions and ensure that the LaserBox is properly assembled and in working order.

Please observe the following operating principles:

- Be sure to check the LaserBox for damage every time before use. Do not operate any damaged or defective LaserBox in any way.
- Please keep the workspace clean and flat. Note that the laser tube is made of glass and is very fragile. If it is broken, the LaserBox will fail to work.
- Without authorization, please do not disassemble or change the LaserBox structure in any other way; and please do not modify or decompile the operating system of the LaserBox.
- Please keep the inside of the LaserBox clean. Residues and chippings accumulated during cutting and engraving are dangerous and may cause fire. Clean the chippings and residues in the honeycomb panel and tray regularly.
- The working temperature of laser is between 5 °C and 25 °C. It is strictly prohibited to operate below 0 °C.

2. Laser safety

Under normal circumstances, the CO2 laser tube is completely enclosed in a casing during operation. The LaserBox has a safety interlock switch. If the lid is lifted during operation, the LaserBox will stop working to prevent harming people. No special precautions are required to ensure laser safety.

Please observe the following safety guidelines:

- Never operate the LaserBox with any parts removed, such as tray. Please note that the absence of any part of the LaserBox may expose the laser system and increase the risk of equipment damage. Remember that the CO2 laser beam is invisible.
- Do not engrave or cut any material that contains PVC or vinyl (processed plastics are not recommended). These materials (and other materials containing chlorine/chloride) can generate corrosive vapor that is extremely harmful to the human body and can cause damage to the LaserBox. Any damage caused by engraving or cutting any material containing PVC or vinyl is not covered by Makeblock's warranty.
- Do not engrave or cut any unknown material. Vaporization/melting of many materials, include, but not limited to, PVC and polycarbonate, will release harmful smoke.
- Laser operation is prohibited when the lid is lifted. Make sure that the LaserBox is closed by the lid during operation and do not tamper with the safety mechanism of the lid.
- Do not operate the LaserBox before properly connecting smoke purifier. Most materials produce irritating smoke when being processed. These include, but are not limited to, paints, varnishes, composite boards, and plastics that can produce hazardous compounds during processing.

The reference standard for laser safety is American National Standard for Safe Use of Lasers (Z136.1-2000), which is provided by the American National Standards Institute (ANSI). This reference is the basis for federal regulations and laser system manufacturers, as well as the laser safety guidelines of Occupational Safety and Health Administration (OSHA). It contains details on the proper installation and use of laser systems.

3.Fire safety

A high-density laser beam is used by the LaserBox to irradiate the material to be cut or engraved, so as to heat up the material surface and vaporize the material without burning. But most materials are inherently flammable and may be ignited to form an open flame that can burn down the LaserBox (even if it is made of flame-retardant materials) and its surroundings. Experience shows that vector cutting with a laser is most likely to produce an open flame. In particular, acrylic has proven to be extremely flammable in vector cutting.

Please read the following warnings and suggestions carefully:

- Please note that stacked materials (especially organic materials such as paper) may cause flame propagation or increase the risk of material ignition.
- Never leave the LaserBox unattended during operation. There is a risk of fire if the LaserBox is started due to incorrect settings and left unattended for long periods of time, or if the LaserBox is mechanically or electrically malfunctioning during operation.
- Clean the LaserBox regularly. Excessive accumulation of residues and chippings from cutting and engraving would increase the risk of fire. Honeycomb panel and tray should be removed and cleaned periodically to ensure that there is no residue or chipping in the LaserBox.
- Keep the area around the LaserBox clean and free of cluttered flammable materials, explosives or volatile solvents such as acetone, alcohol or gasoline. Provide fire extinguishers, and perform regular maintenance and inspection.

4.Electrical equipment safety

Laser tube of the LaserBox has a silicone rubber casing, which can effectively shield the internal power cord. If you find the cover is loose and the power cord is exposed, stop operating and contact customer service personnel.

Please carefully read and strictly observe the following warnings and suggestions:

- When the LaserBox is connected to the power supply, do not open any access panel on the LaserBox to avoid harm from accidental contact with the power supply.
- When the LaserBox is connected to the power supply, do not touch the electronic-related area with your hands or other tools.
- Power button of the LaserBox is at the rear of it. Pressing (-) to power it on and pressing "o" to power it off.

List of Items

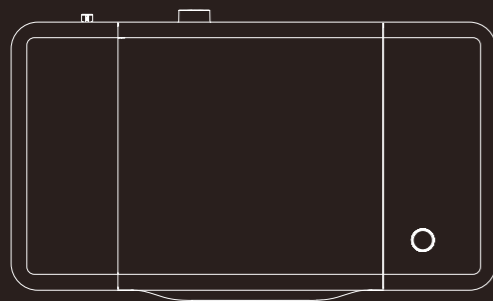

LaserBox × 1

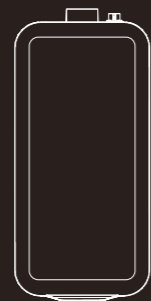

Smart Smoke Purifier × 1

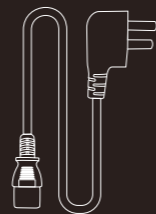

Power Cord ×



USB Cable × 1

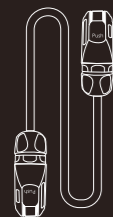

Aviation Connector ×

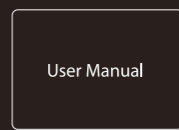

User Manual ×

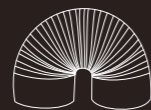

Smoke Exhaust Pipe × 2



Pipe Clamp × 3

Meet Your LaserBox

LaserBox

Button	1
Annular Indicator	2
Power Button	3
Power Interface	4
USB Interface	5
Ethernet Cable Interface	6
Smoke Outlet	7
Aviation Interface	8

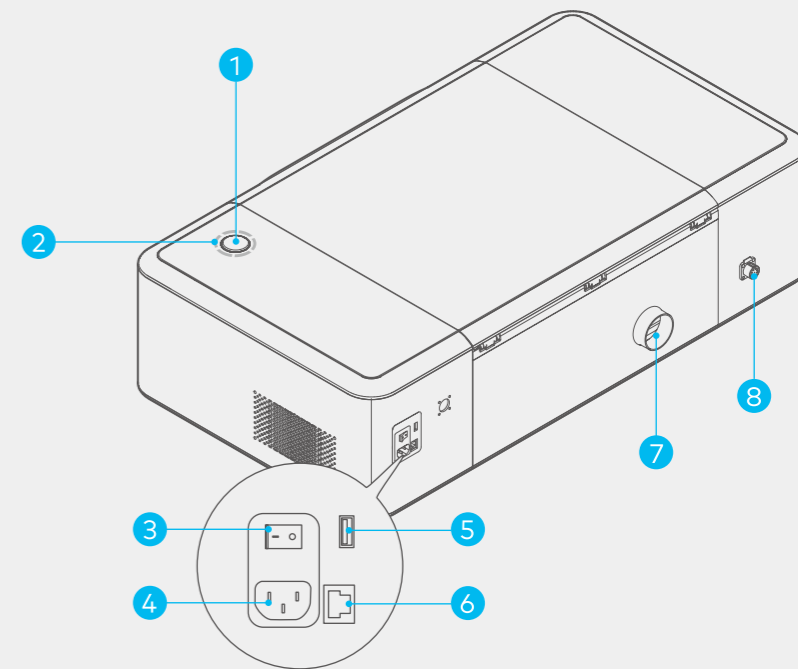

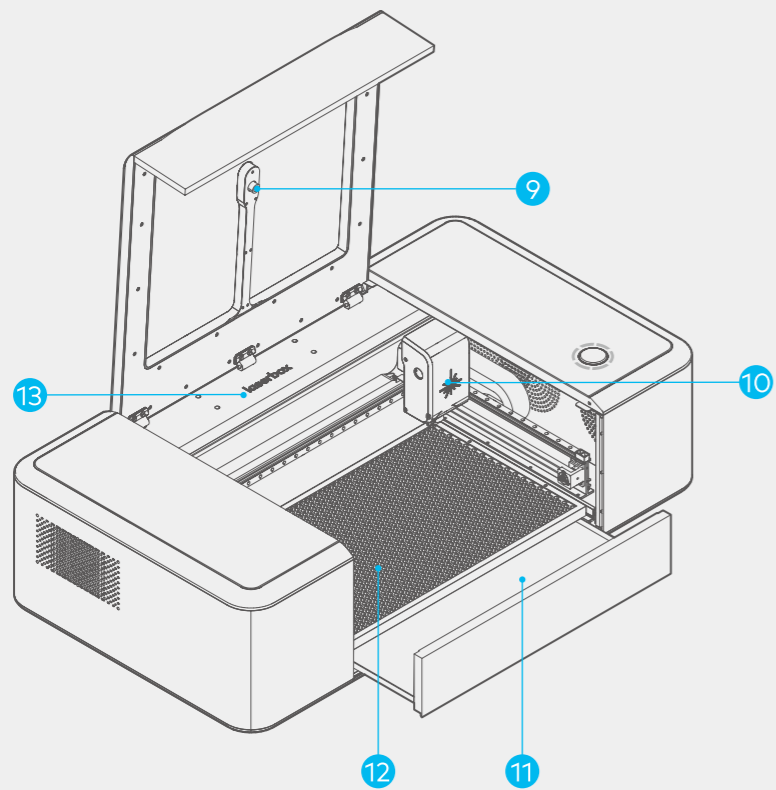

- Camera 9
- Laser Head 10
- Tray 11
- Honeycomb Panel 12
- Laser Tube 13

Smart Smoke Purifier

- HEPA Composite Filter 1
- Indicator 2
- Aviation Interface 3
- Smoke Inlet 4
- Smoke Outlet 5

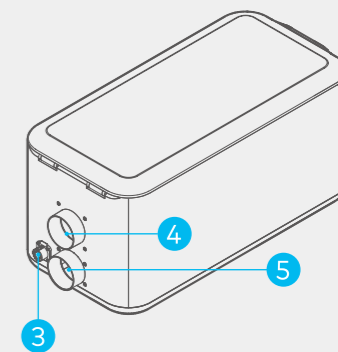
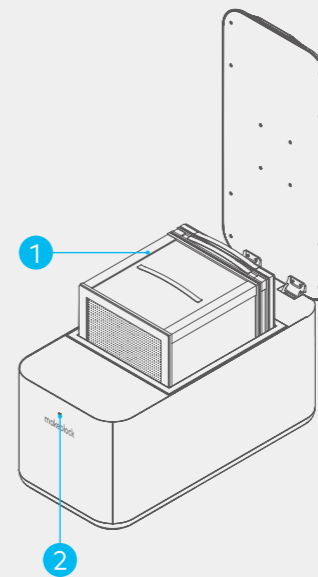



Quick Operation Guide

Connect the smart smoke purifier

1. Connect the purifier with the 2m-exhaust pipe and lay the pipe to the window.
2. Connect the LaserBox and purifier with the 1.5m-exhaust pipe.
3. Connect the LaserBox and purifier with the aviation connector.
4. Connect the power supply.

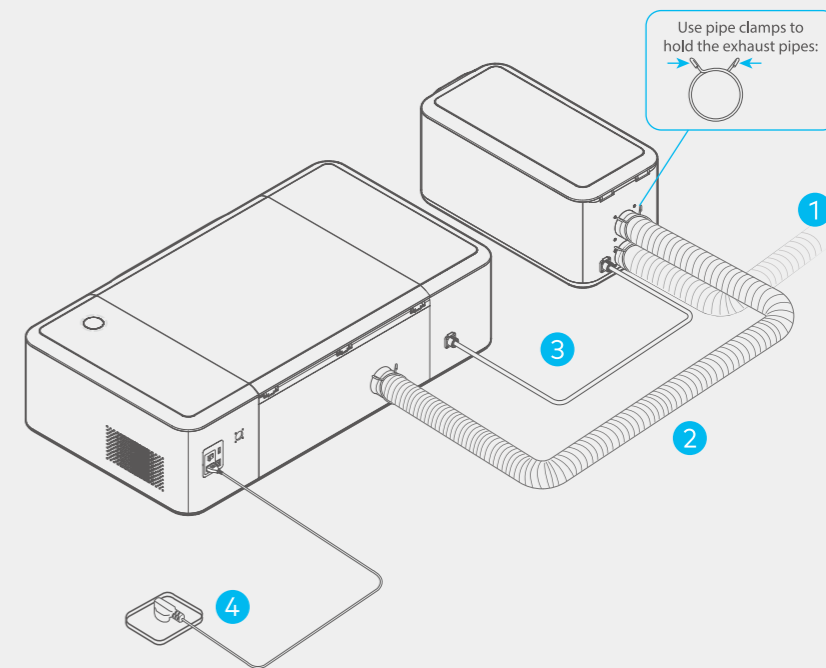

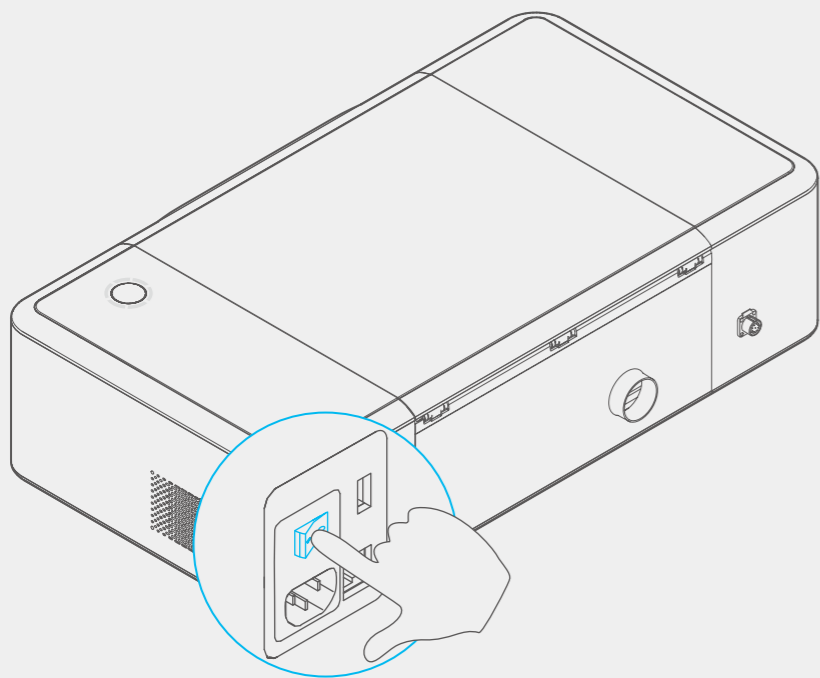

Start the LaserBox

After pressing the power button, the laser head will automatically reset and calibrate. After the first startup, the annular indicator will turn solid white. The startup process takes a while, and please be patient.

Connect a computer to the LaserBox

LaserBox software is required for the connection of a computer to the LaserBox. Please download and install the software at the following website.

<https://www.makeblock.com/maker-tools/laserbox>

There are three ways to connect a computer to the LaserBox. Choose the best according to your situation.

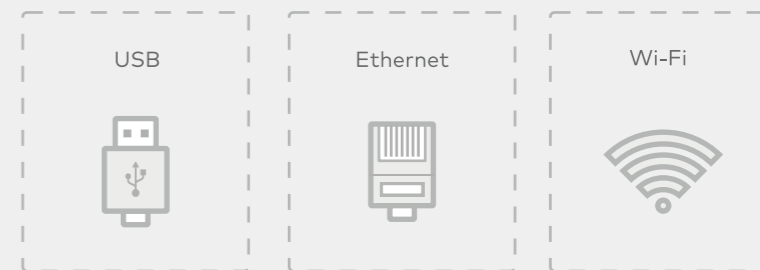

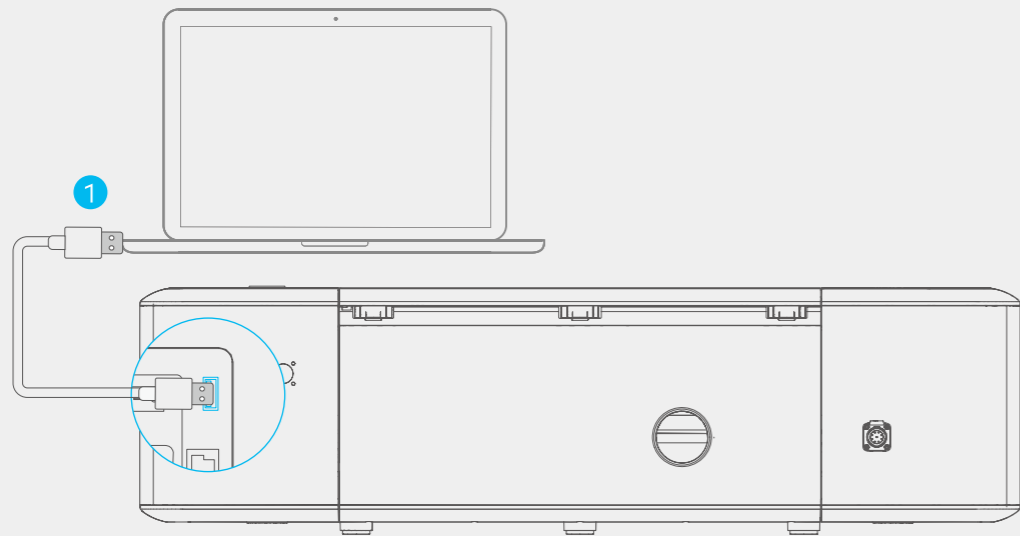

- Connect with the USB cable

1. Connect a computer to the LaserBox with the USB cable.

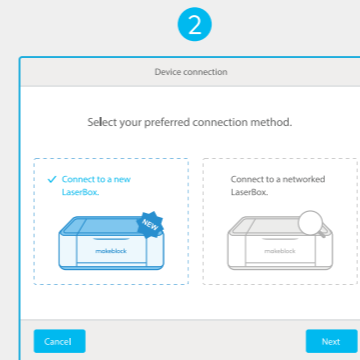

2. Open the software, select "Connect to a new LaserBox" and click "Next".

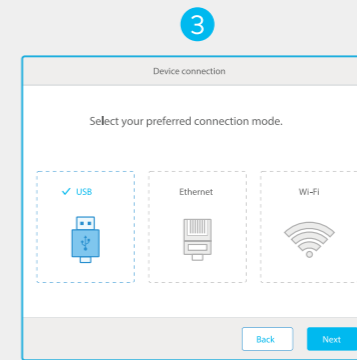

3. Select "USB" and click "Next" to start the connection.

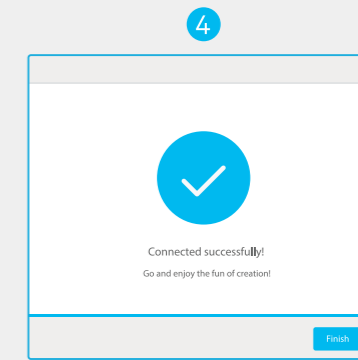

4. Successful connection.

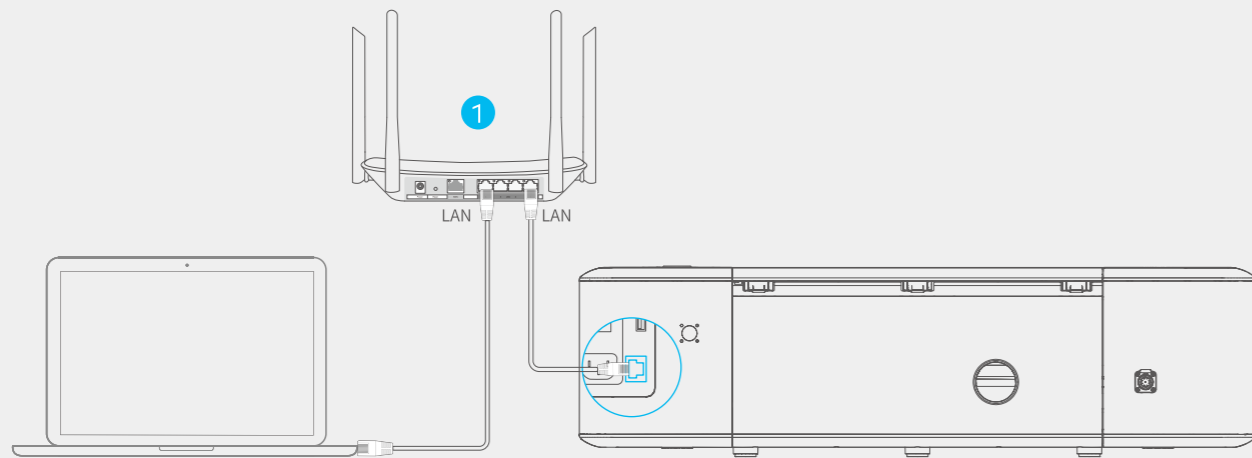

- Connect with an Ethernet cable (not included in the package)

1. Connect a computer and the LaserBox to the router's LAN ports with Ethernet cables.

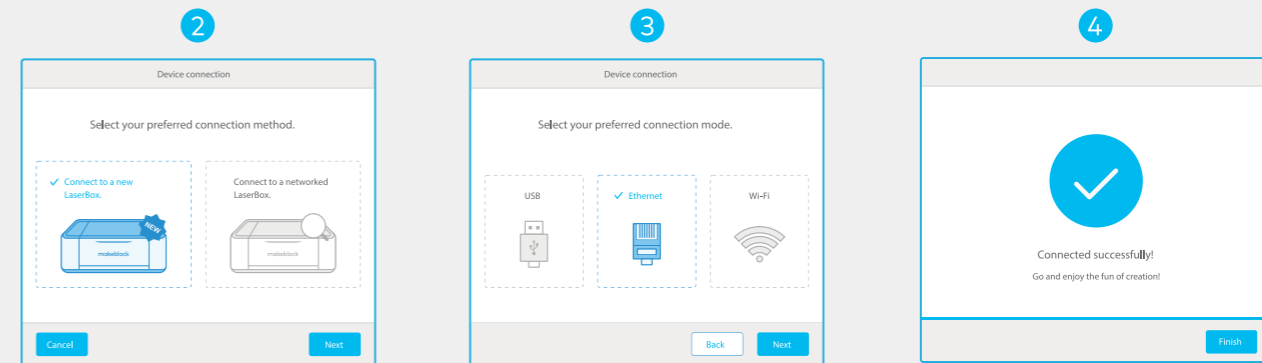

2. Open the software, select "Connect to a new LaserBox" and click "Next".

3. Select "Ethernet" and click "Next" to start the connection.

4. Successful connection.

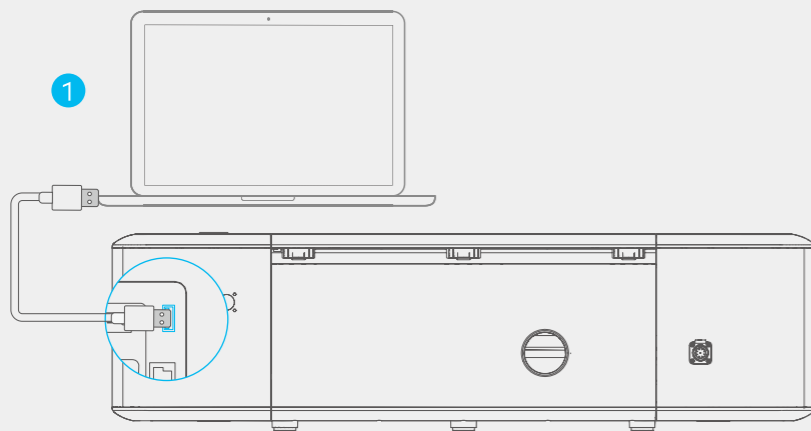

- Wi-Fi wireless connection

1. Connect a computer to the LaserBox with the USB cable.

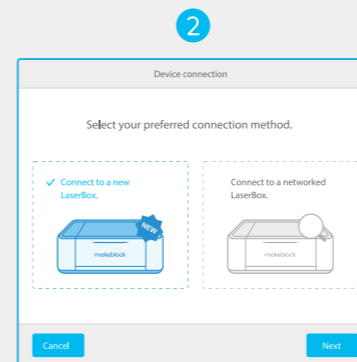

2. Open the software, select "Connect to a new LaserBox" and click "Next".

5. After successful connection, you can disconnect the USB cable and wirelessly control the LaserBox.

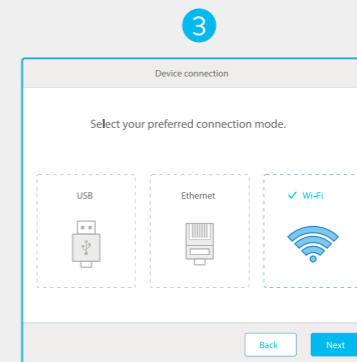

3. Select "Wi-Fi" and click "Next".

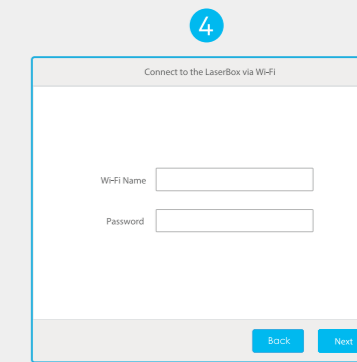

4. Connect to the existing Wi-Fi network.

Start cutting / engraving



1 Place the official materials in the LaserBox working area.

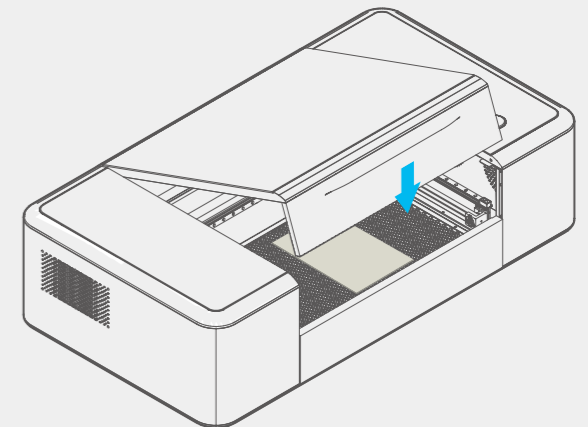
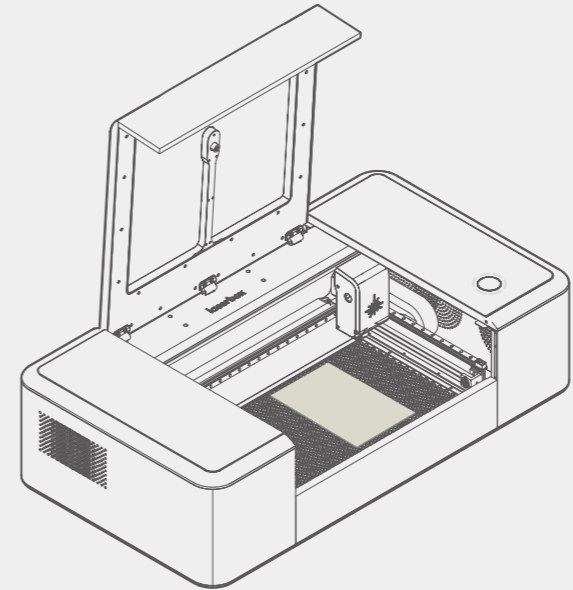

Note: Cutting/Engraving Material Requirements can be found in the appendix.

Open the LaserBox software and select the sample image. You can also import or draw images yourself.

2



Click "Send" to send the image to the LaserBox. After the transmission is completed, the LaserBox would be ready, and the annular indicator would turn flashing blue.

4

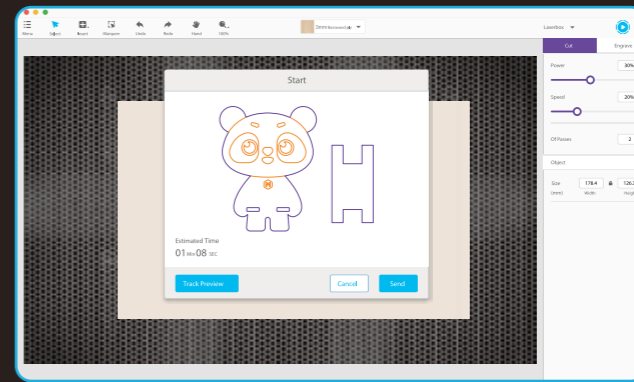

Click the "Start" button. The LaserBox can automatically identify official materials and set cutting/engraving parameters.

3

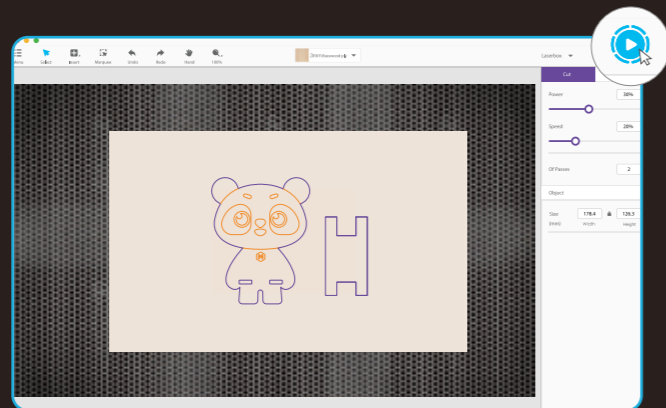

Press the button on the LaserBox to start cutting/engraving.

5

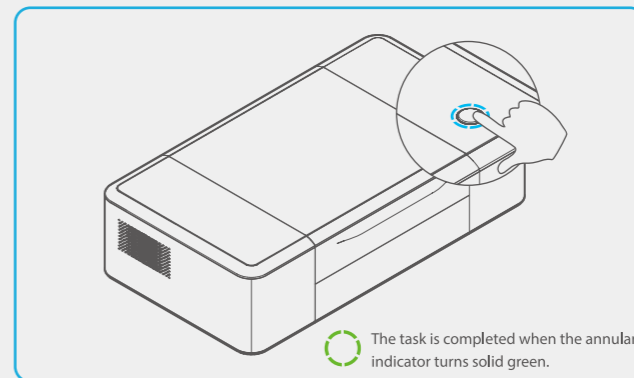

Method 1:

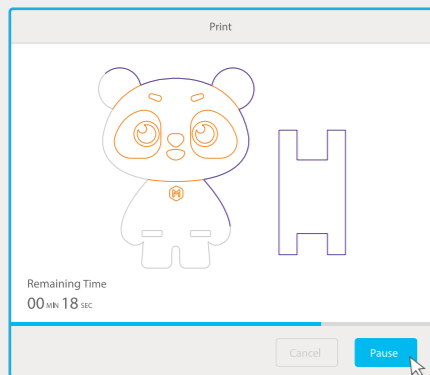

Method 2:

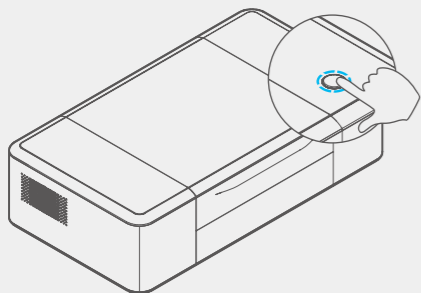

Method 3:

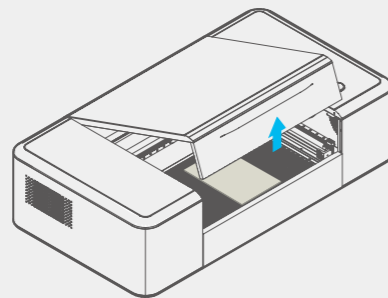

More Operations

Pause the task

Method 1: Click "Pause" in the software interface to pause the task.

Method 2: Press the button on the LaserBox to pause the task. Press again to continue with the task.

Method 3: Open the lid to pause the task. Close the lid and press the button on the LaserBox to continue with the task.

Cancel the task

1. Open the lid.

2. Press and hold the button for 5 seconds. After the task is cancelled successfully, you will hear a beep sound and the annular indicator turns from red to blue.

1

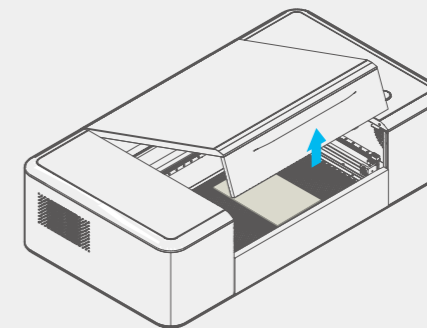

2

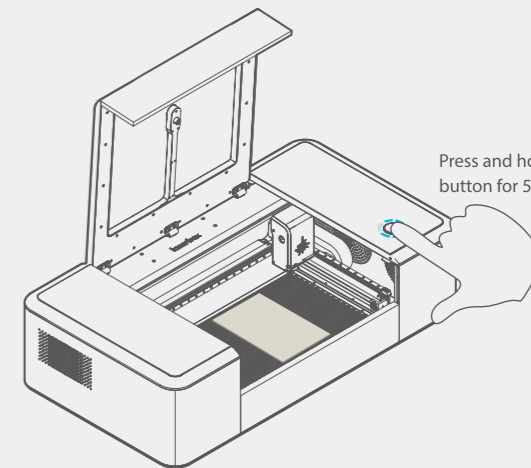

Press and hold the button for 5 seconds.

Note: After starting cutting/engraving, you can also cancel the task by clicking "Pause -> Cancel" in the LaserBox software interface.

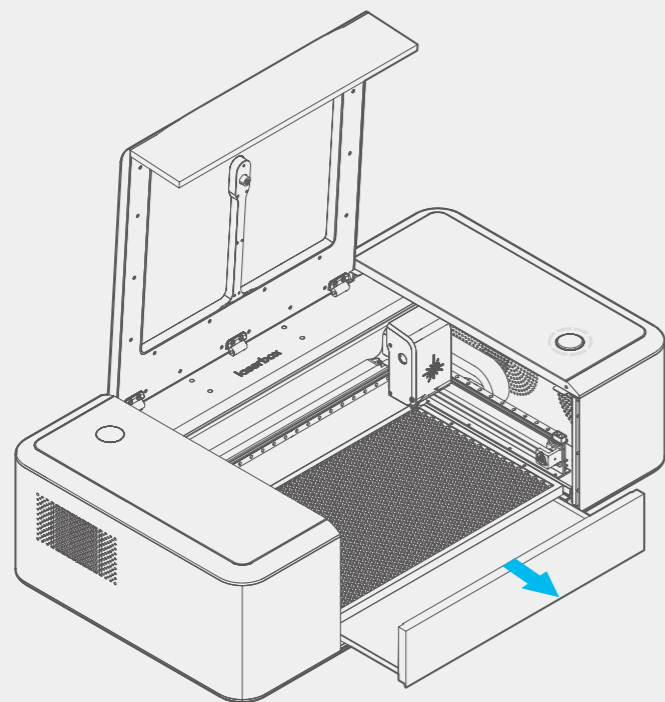

Clean chippings

Residues and chippings accumulated during operation of the LaserBox should be cleaned regularly, otherwise it may cause a fire. Pull out the tray as shown to clean up residues and chippings.

More Features

Bring sketch to life

Draw on copy paper or official materials with a black/red oil-based pen. For images drawn with a black oil-based pen, the LaserBox will cut along the contour and the black area will be engraved. Images drawn with a red oil-based pen will be cut directly along the handwriting.

1. Draw an image, preferably with a Deli S550 oil-based marker.
2. Place the material and close the lid.
3. Press the button on the LaserBox to start the task.

1

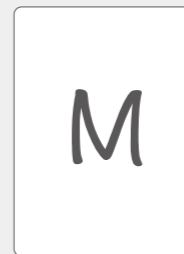

2

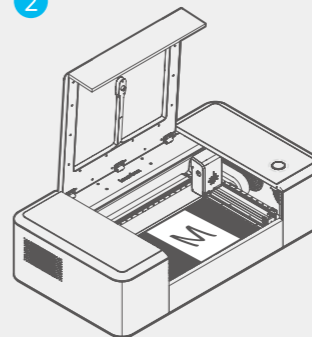

3

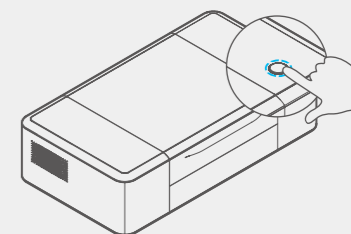

Note: For optimal cutting / engraving effect, it is recommended to use the Deli S550 oil-based marker, draw the image as far as possible from the ring code and the edge of the material, and place the material in the center of the honeycomb panel. Only with copy paper and official materials, you can bring sketch to life. Damages caused by the use of other materials are not covered by Makeblock's warranty service.

1

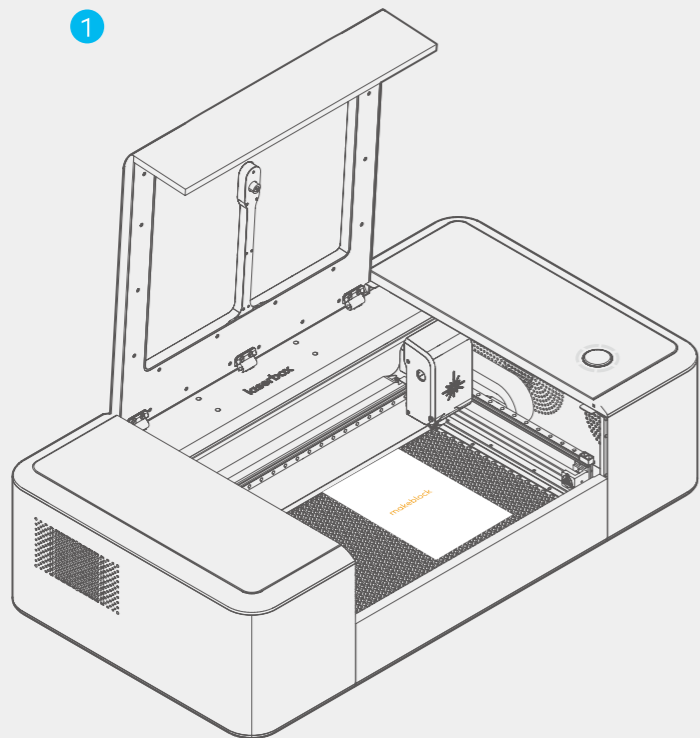

Image extraction

The LaserBox has a built-in camera that extracts the surface image for further creation.

1. Place the object for image extraction.

2. Start the LaserBox and select "Marquee" to put the image you want to extract in a selection box.

3. Successful image extraction.

2

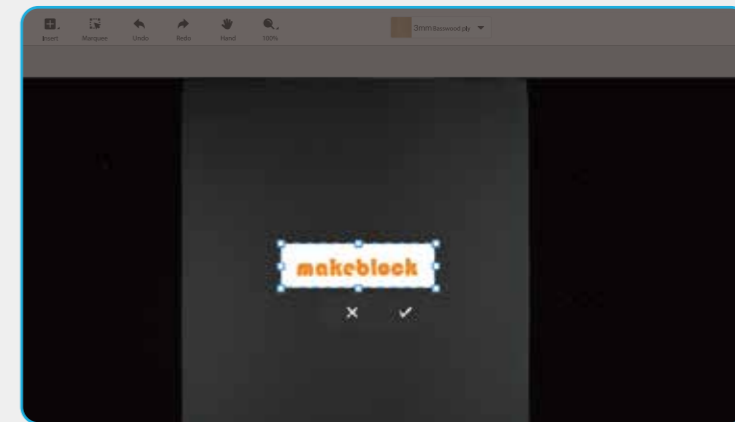

3



Appendix 1: Cutting/Engraving Material Require-

Maximum dimensions for cutting: 500 (length) * 300 (width) * 22 (thickness) mm

Materials for cutting/engraving:









Paper	Cordboard
Wood board	Acrylic
Cloth	Base plate
Leather	ABS-based color board
PET	Rubber
Wood veneer	Glass fiber
Plastic	Corian

Materials not recommended:

Uneven material
Humid material
Dirty material
Out-of-gauge material

Note: The use of poor quality materials may result in poor cutting/engraving. It is recommended to use Makeblock official materials.
The use of the materials not recommended above may damage the device, and the resulting damages are not covered by Makeblock's warranty service.

Appendix 2: Annular Indicator Status Description

Indicator status	Description
 Flashing white	The system gets started.
 Solid white	Waiting to connect.
 Flashing blue	It is ready and the image has been sent successfully.
 Solid blue	It is in the standby mode and the LaserBox has been connected to the computer.
 Six indicators light up gradually	It is in the working status, and the number of indicators that are ON indicates the current progress.
 Solid green	Completion.
 Green breathing indicator	Sleep mode. It goes into the sleep mode from the standby mode after 10 minutes idle.
 Solid red	Abnormal.
 Solid purple	The LaserBox firmware is being upgraded.

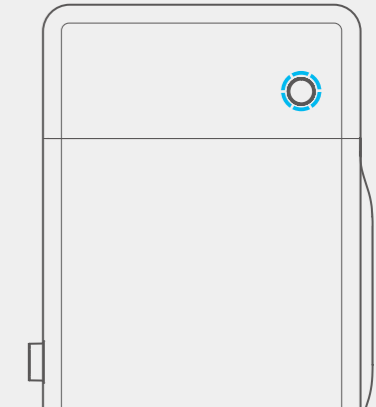



DECLARATION OF CONFORMITY

Declaration of conformity Hereby, Makeblock Co., Ltd., declares that this product is in compliance with the essential requirements and other relevant provisions of Directive RED 2014/53/EU and the RoHS directive 2011/65/EU

Product Warranty Information

Warranty coverage	Part name	Warranty period	Warranty service type
Main parts	PCB parts, motor, camera, and other parts other than consumable parts and materials	12 months (professional education version) 6 months (standard version)	On-site service / return for repair
Consumable parts	Laser tube, guide rail and conveyor belt, etc.		
Consumable materials	HEPA Composite Filter and wood board etc.	No warranty period (It can be replaced free of charge in case of factory damage)	
Accessories	Power cord, aviation connector, user manual, pack and honeycomb panel etc.		

Notes and instructions:

- ①The above "warranty period" is from the date of purchase on the receipt, with the invoice date as a reference. Please keep your purchase invoice on record. In the absence of a valid invoice, the warranty period will be counted from the ex-factory date.
- ②Warranty service mode is specified by Makeblock or an appropriately certified technical testing personnel based upon the technician's judgement of the problem. On-site service is only provided for hardware failures. Software failures will not be eligible for on-site service.

Beyond warranty coverage

The warranty under the document does not apply to the following:

- The warranty has expired for the products or parts;
- Failure or damage caused by incorrect or improper use, maintenance or storage, such as: improper handling; use for purposes not as properly intended; improper insertion and removal of external equipment; drop or improper external force extrusion; contact or exposure to inappropriate temperature, solvent, acid, alkali, water immersion and other environments; and breaking & cracking, rusting and damage of products or parts (such as casing, components, and circuits etc.) due to insect, rat bites, or any foreign materials;
- Failure or damage due to installation, repair, alteration, addition or removal by any agency or personnel not authorized by Makeblock;
- The original identification information of products or parts is modified, altered or removed;
- No valid purchase invoice or warranty card, except as otherwise provided herein;
- Failure or damage caused by the use of software that is not legally authorized, non-standard or non-publicly released;
- Failure or damage due to virus infection, hacker attack or other malicious infringements;
- Failure or damage due to force majeure or accident;
- Other failure or damage due to non-quality factors of the products;
- The product can run without interruption or error.

In the above circumstances, you shall seek resolution from the relevant responsible parties, and Makeblock assumes no responsibility for them. Product failure falling beyond the warranty coverage due to parts, accessories, or software not covered by warranty or whose warranty has expired, shall be dealt with by upgrading and repairing these parts, accessories, and software in accordance with the relevant warranty provisions. Normal discoloration, wear and tear during use of the product are not covered by the warranty.

Product information

Product serial number:

FCC STATEMENT :

This device complies with Part 15 of the FCC Rules. Operation is subject to the following two conditions:

- (1) This device may not cause harmful interference, and
- (2) This device must accept any interference received, including interference that may cause undesired operation.

Warning: Changes or modifications not expressly approved by the party responsible for compliance could void the user's authority to operate the equipment.

NOTE: This equipment has been tested and found to comply with the limits for a Class B digital device, pursuant to Part 15 of the FCC Rules. These limits are designed to provide reasonable protection against harmful interference in a residential installation. This equipment generates uses and can radiate radio frequency energy and, if not installed and used in accordance with the instructions, may cause harmful interference to radio communications. However, there is no guarantee that interference will not occur in a particular installation. If this equipment does cause harmful interference to radio or television reception, which can be determined by turning the equipment off and on, the user is encouraged to try to correct the interference by one or more of the following measures:

- Reorient or relocate the receiving antenna.

- Increase the separation between the equipment and receiver.

- Connect the equipment into an outlet on a circuit different from that to which the receiver is connected.

- Consult the dealer or an experienced radio/TV technician for help.

FCC Radiation Exposure Statement:

This equipment complies with FCC radiation exposure limits set forth for an uncontrolled environment. This equipment should be installed and operated with minimum distance 20cm between the radiator & your body.

- English: "

This device complies with Industry Canada licence-exempt RSS standard(s). Operation is subject to the following two conditions:

- (1) this device may not cause interference, and
- (2) this device must accept any interference, including interference that may cause undesired operation of the device."

- French:"

Le présent appareil est conforme aux CNR d'Industrie Canada applicables aux appareils radio exempts de licence. L'exploitation est autorisée aux deux conditions suivantes :

- (1) l'appareil n' doit pas produire de brouillage, et
- (2) l'utilisateur de l'appareil doit accepter tout brouillage radioélectrique subi, même si le brouillage est susceptible d'en compromettre le fonctionnement."