

此页不印刷

xTool_M2_用户手册_多语言_V1.0_D1.1.6

料号:KD010767000

成品尺寸:210*280mm

展开尺寸:420*280mm

材质:封面250g铜版纸,内页100g铜版纸

工艺:封面覆哑膜,双面CMYK印刷,胶装

XTOOL

User Manual | Benutzerhandbuch | Manual de Usuario | Manuel
d'utilisation | Manuale utente | Manual do Usuário |
Gebruikershandleiding | 取扱説明書 | 사용자 매뉴얼 | 用戶手冊 | 用戶手冊

XTOOL





EN	Video tutorial: support.xtool.com/article/1291	PT	Tutorial em vídeo: support.xtool.com/article/1291
DE	Video-Anleitung: support.xtool.com/article/1291	NL	Video-handleiding: support.xtool.com/article/1291
ES	Tutorial en vídeo: support.xtool.com/article/1291	JA	ビデオ・チュートリアル: support.xtool.com/article/1291
FR	Tutoriel vidéo: support.xtool.com/article/1291	KO	비디오 튜토리얼: support.xtool.com/article/1291
IT	Video tutorial: support.xtool.com/article/1291	ZH-TW	視頻教程: support.xtool.com/article/1291



ZH 视频教程: yuque.com/makeblock-help-center-zh/xgren8/video_tutorial

EN

Statement	02
Safety first (important)	02
List of items	04
Meet your xTool M2	06
Preparations	08
Use xTool M2	12
Indicator description	21
Maintenance	22
FAQs	24
Declaration of conformity	24
FCC statement	24
FCC Radiation Exposure Statement	24
After-sales services	24

Statement

Thank you for choosing xTool products!

If you use the product for the first time, read carefully all the accompanying materials of the product to improve your experience with it. If you do not use the product according to the instructions and requirements of the Manual, or mis-operate the product due to misunderstanding, etc., the Company shall bear no responsibility for any loss resulting therefrom.

The Company has collated the content of the Manual rigorously and carefully, but errors or omissions may remain.

The Company is committed to continuously improving product functions and service quality, and therefore reserves the right to change any product or software described in the Manual and the content of the Manual at any time.

The Manual is intended to help you use the product properly and

does not include any description of hardware and software configuration. For product configuration, refer to the related contract (if any) and packing list, or consult your distributor. Images in the Manual are for reference only and the actual product may vary.

Protected by copyright laws and regulations, the Manual shall not be reproduced or transcribed in any way, or be transmitted on any wired or wireless network in any manner, or be translated into any language, or be modified in any way, such as content, image, or layout modification, without the prior written authorization of the Company.

The Company is committed to continuously improving the product and related materials. The product and the Manual are subject to change, and updates can be found at xtool.com.

Safety first (important)

1. General safety

Read and get familiar with all safety precautions and procedures before using the machine. Strictly follow all safety precautions. Ensure that the machine is properly assembled.

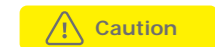

Follow the operating principles:

- Check the machine for damage every time before you use it. Do not operate it in any way when any damage or defect is found.
- Ensure that the workspace is clean and flat.
- Do not disassemble the machine or change its structure in any way without authorization. Do not modify or decompile its operating system.
- Do not leave the device unattended during operation. Pay attention to whether it is working properly.
- Keep the inside of the machine clean. Residues and chippings accumulated during cutting and engraving are dangerous and may cause a fire. Clean the chippings and residues inside the work area regularly.
- The machine works properly at the temperature of 0°C to +35°C and can be stored properly at the temperature of -10°C to +40°C. Do not operate it at a temperature lower than 0°C.

2. Laser safety

Generally, the laser module is completely enclosed in the casing and light shield during operation. The device has a safety interlock switch. If the lid is lifted during operation, the device will stop working and no harm will be done to people.



Follow the safety precautions:

- Do not operate the machine when any part of it is removed. Removing any part may expose the laser system and cause damage to the machine.
- Do not engrave or cut any material that contains PVC or vinyl (processing plastics is not recommended). These materials (and other materials containing chlorine/chloride) can generate corrosive vapor that is extremely harmful to the human body and can cause damage to the device. Any damage caused by engraving or cutting any material containing PVC or vinyl is not covered by the Company's warranty.
- Do not engrave or cut any unknown materials. Vaporization or melting of many materials, which include but are not limited to PVC and polycarbonate, may release harmful smoke.
- Laser operation is prohibited when the lid is lifted. Make sure that the lid is closed during operation and do not tamper with the safety mechanism of the lid.
- Do not leave the device unattended during operation. Pay attention to whether it is working properly.

The reference standards for laser safety are the American National Standard for Safe Use of Lasers (Z136.1-2022), International Electrotechnical Commission Standard (IEC 60825-1:2014), and European Standards (EN 60825-1:2014/A11:2021).

3. Fire safety

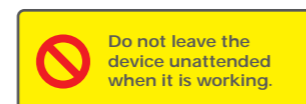

Do not leave the device unattended when it is working.

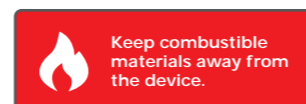

Keep combustible materials away from the device.

A high-density laser beam is used by the device to irradiate the material to be cut or engraved, so as to heat up the material surface and vaporize the material without burning. But most materials are inherently flammable and may be ignited to form an open flame that can burn down the device (even if it is made of flame-retardant materials) and its surroundings. Experience shows that vector cutting with a laser is most likely to produce an open flame. In particular, acrylic has proven to be extremely flammable in vector cutting.



Read the following warnings and suggestions carefully:

- Ensure that the workspace is well-ventilated so that the generated smoke can be discharged in time.
- Do not stack materials (especially organic ones, such as paper) around the machine. They may cause the spread of flames and increase the risk of material ignition.
- Do not leave the machine unattended when it is working. If the machine works with setting errors and is left unattended for a long period of time, or if a mechanical or electrical fault occurs, a fire may be caused.
- Clean the device regularly. Excessive accumulation of residues and chippings from cutting and engraving would increase the risk of fire. The internal working area needs to be cleaned periodically to ensure that there is no residue or chipping inside the device.
- Ensure that the area around the machine is clean without any cluttered flammable materials, explosives, or volatile solvents, such as acetone, alcohol, or gasoline.
- Keep a fire extinguisher and perform regular maintenance and inspection of it.
- If a fire occurs during processing, take good care of yourself. For a small flame, you can wait for it to go off; for a larger fire, please keep a safe distance and use a fire extinguisher to put it out.

4. Electrical safety



Read the following warnings and suggestions carefully:

- Do not open any access panel on the device when the device is connected to the power supply. Accidental contact with the power supply may cause injury.
- Do not touch any electronic area with your hands or other tools when the machine is connected to a power supply.

5. Blade safety



- Prevent blade contact with your fingers when removing the laser module or blade, or you may get hurt.
- Blades are very sharp. Be careful not to hurt your hands when installing or replacing them.
- Place the used blades in a container that can prevent sharps from hurting people, such as a metal box, seal the container, and dispose of it.

6. Warning and instruction signs

On xTool M2, the warning and instruction signs are labeled where physical injuries or damage to the machine may be caused before and/or during operation. If a sign is damaged or lost, replace it immediately. You can use the following template to print the sign you need.

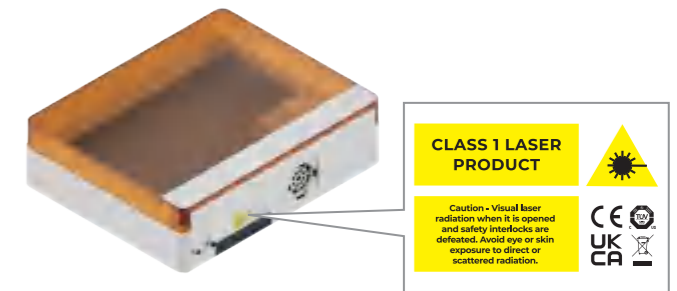

Maximum RF transmit power: Wi-Fi 2.4G (2412-2472 MHz) < 20 dBm

List of items

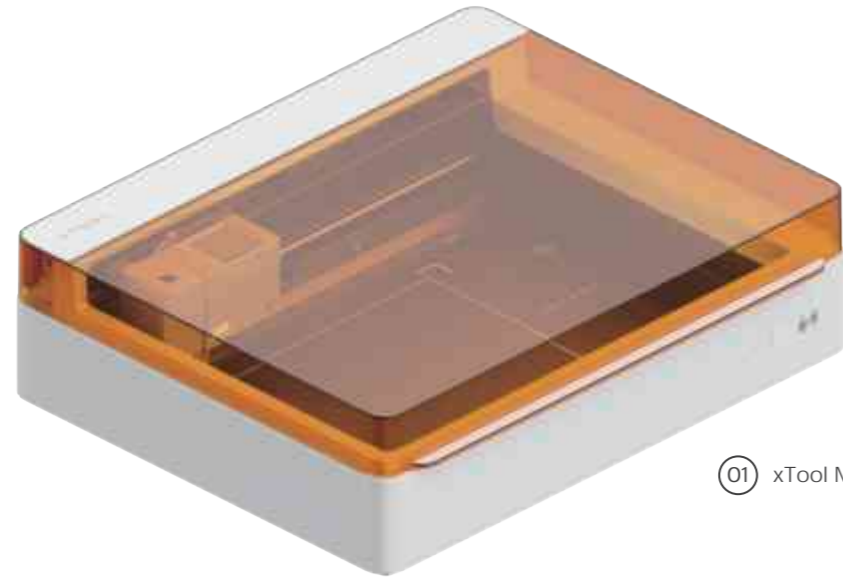

01 xTool M2



02 Laser module



03 Smoke exhaust module



04 USB cable



05 Power cable and adapter



06 Fine-point blade



07 Fine-point pen



08 Pen holder

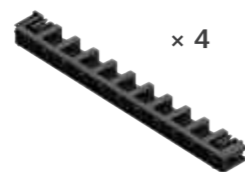

09 Triangular prism holder



10 Triangular prism



11 Cutting mat (LightGrip)



12 Cutting mat (FabricGrip)



13 Filter

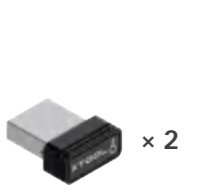

14 Key



15 Crease



16 Material pack



17 Lens mount (spare part)

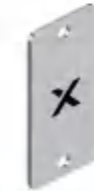

18 Lens mount rotating piece



19 Screwdriver



20 User manual



21 Multi-function carriage



22 Cutting blade

Not all the kits include the multi-function carriage and its accessories.

Meet your xTool M2

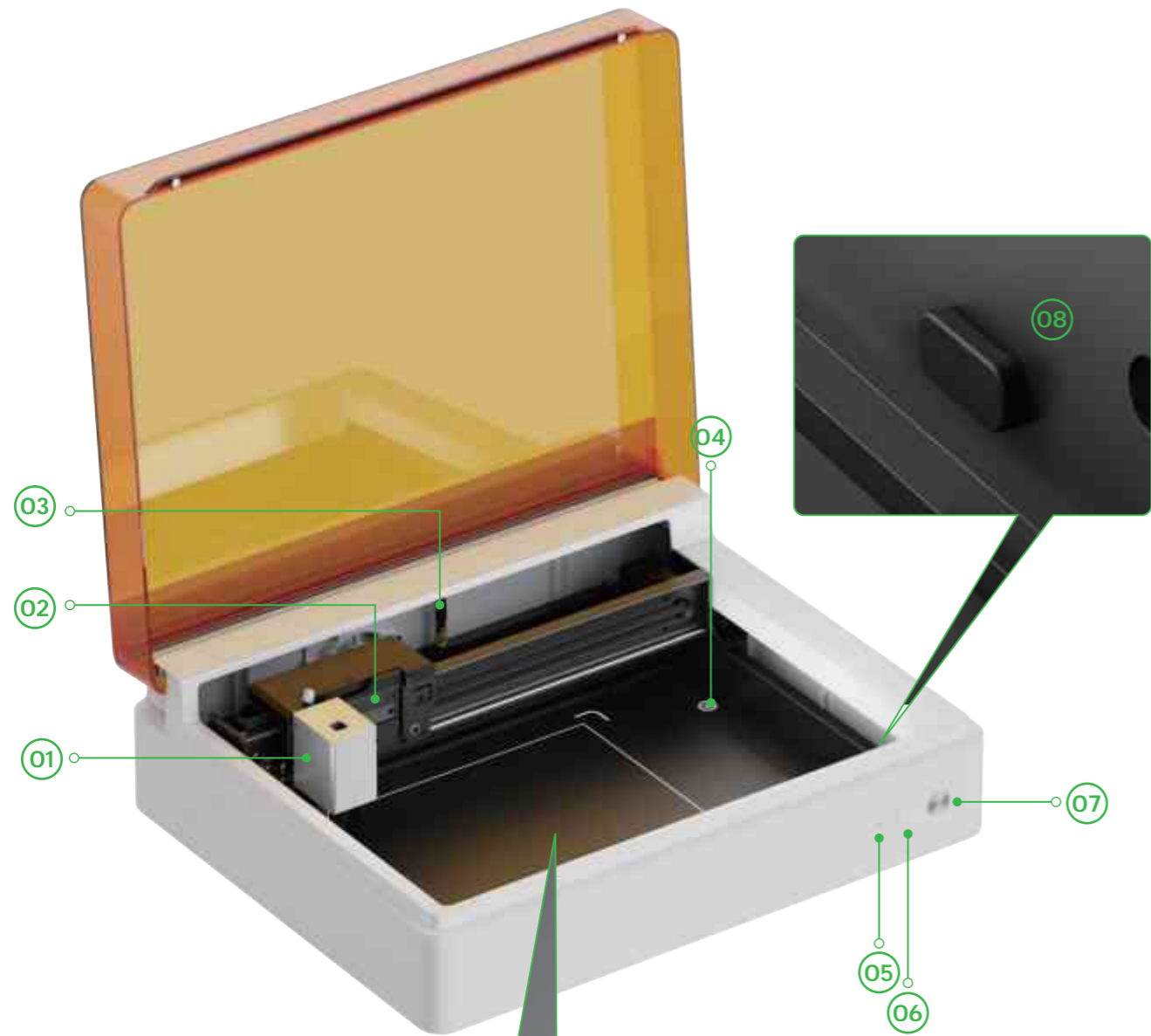

- | | | |
|----------------------------|---|-----------------------|
| 01 Basic carriage | 07 Start/Stop button | 13 Power port |
| 02 Multi-function carriage | 08 Rotary Attachment port | 14 Port for the key |
| 03 Wi-Fi antenna | 09 Thumb screw for the baseplate | 15 Extension port × 4 |
| 04 Camera viewfinder point | 10 Tube fitting for the air assist set | 16 USB port |
| 05 Indicator | 11 Tube fitting for the fire safety set | 17 Smoke outlet |
| 06 Point marking button | 12 Power switch | |

Preparations

1

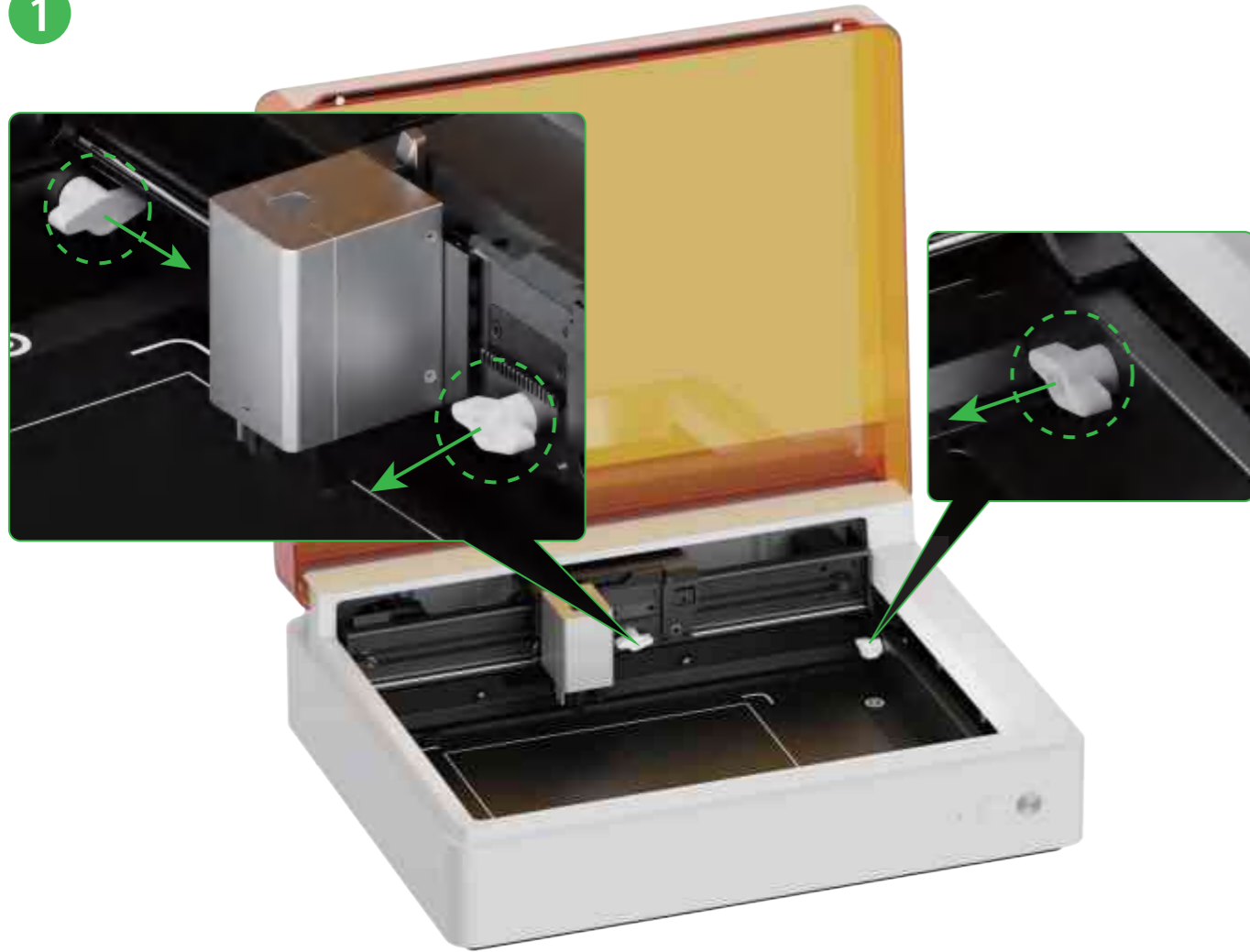

2

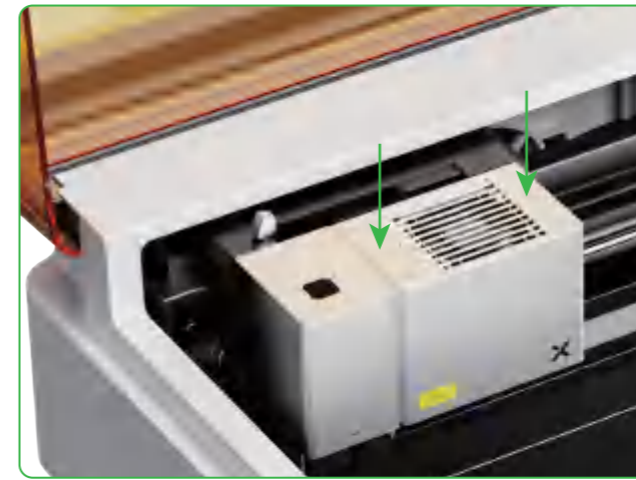
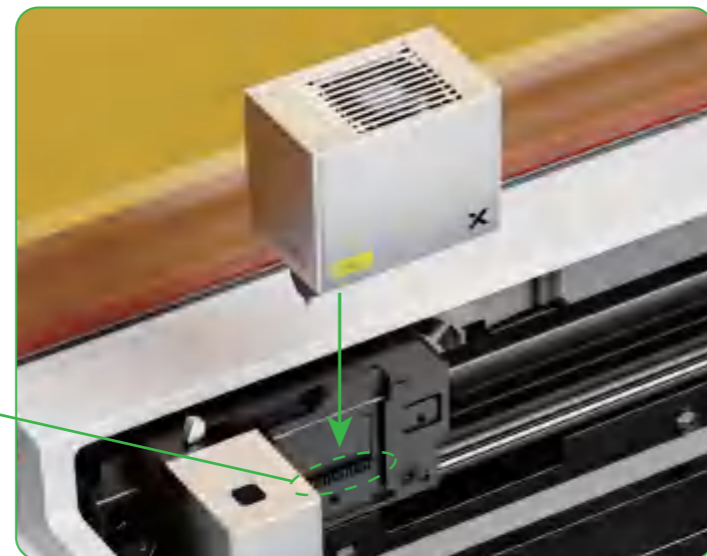

Press the laser module down until you hear a click.

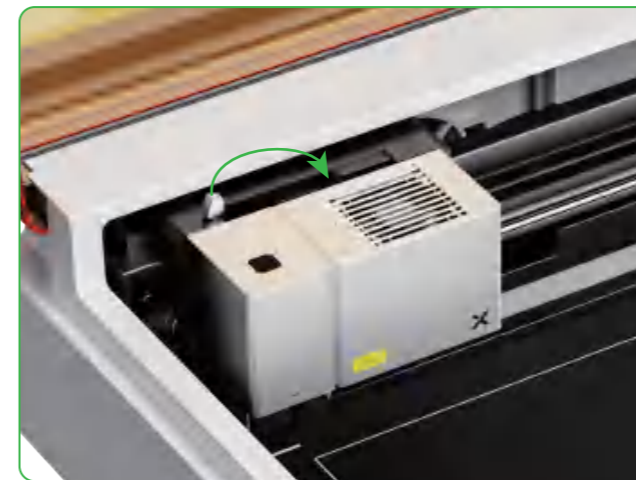

3



Do not use the smoke exhaust module without the filter. Or it may absorb smoke and dust and get damaged.



4



Insert the key to unlock the processing and related functions. You can remove the key to lock the processing and related functions.

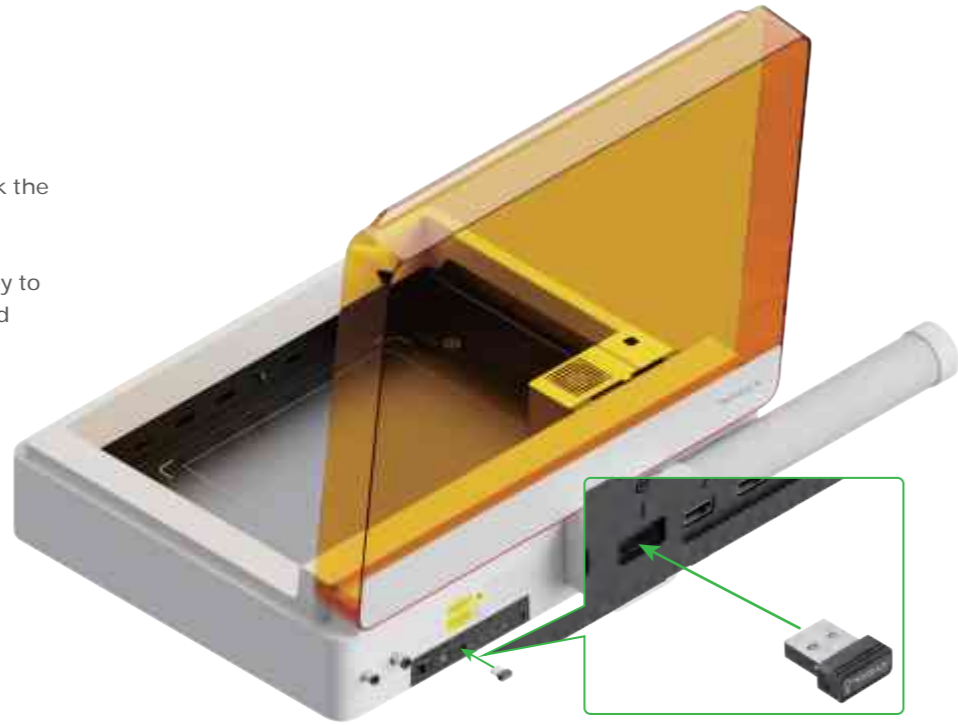

5

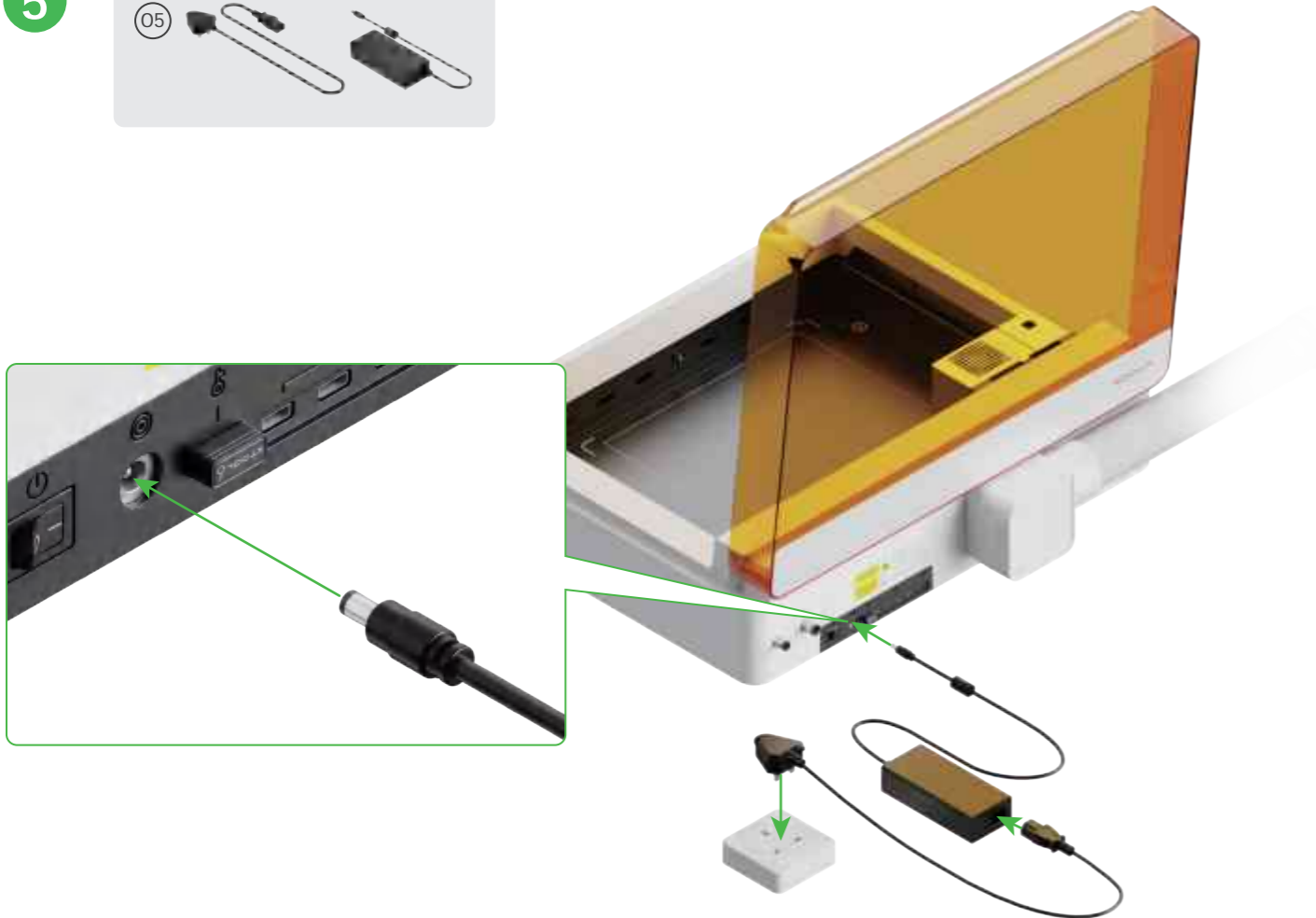
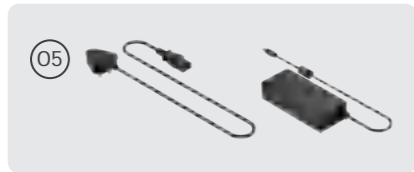

6



Go to xtool.com/software to download and install xTool Creative Space (XCS).

Search for **xTool Creative Space** in the App store or scan the following QR code to download the App.

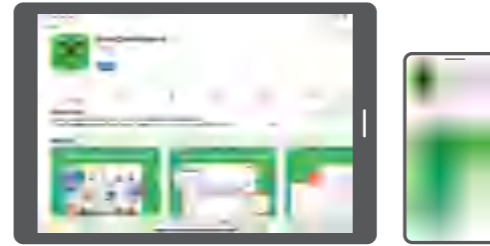

7

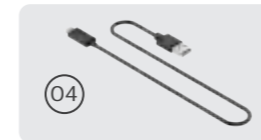

Turn on xTool M2, connect it to a device, and then connect it on XCS.



To know more details, scan the following QR code.



support@xtool.com

Use xTool M2

For laser cutting

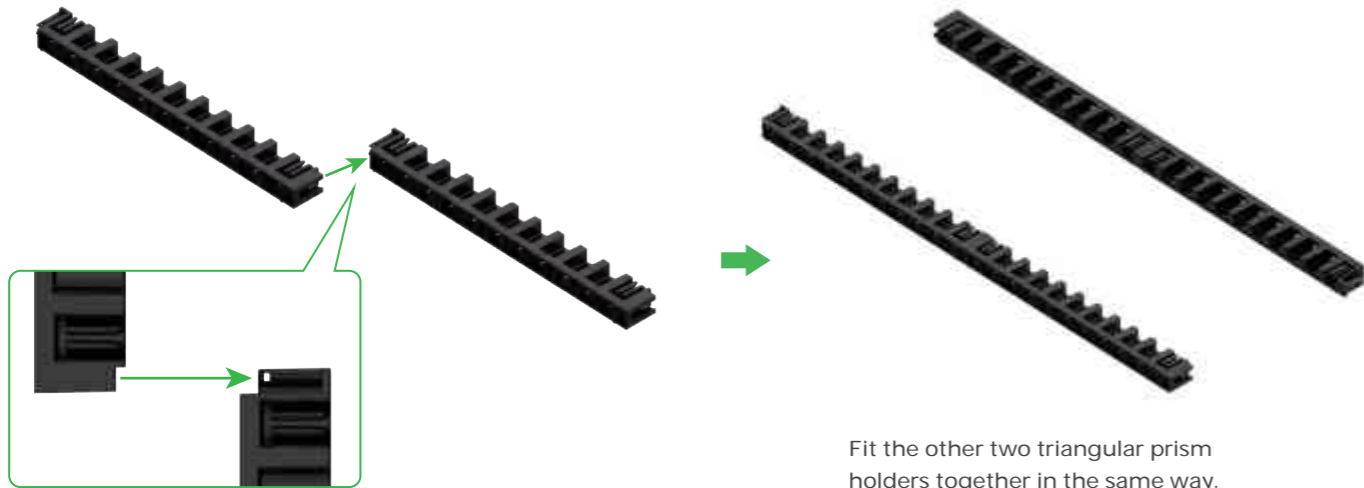
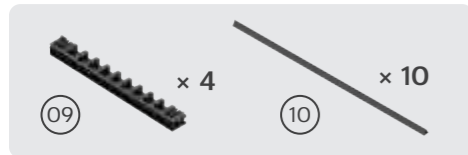

Fit the other two triangular prism holders together in the same way.

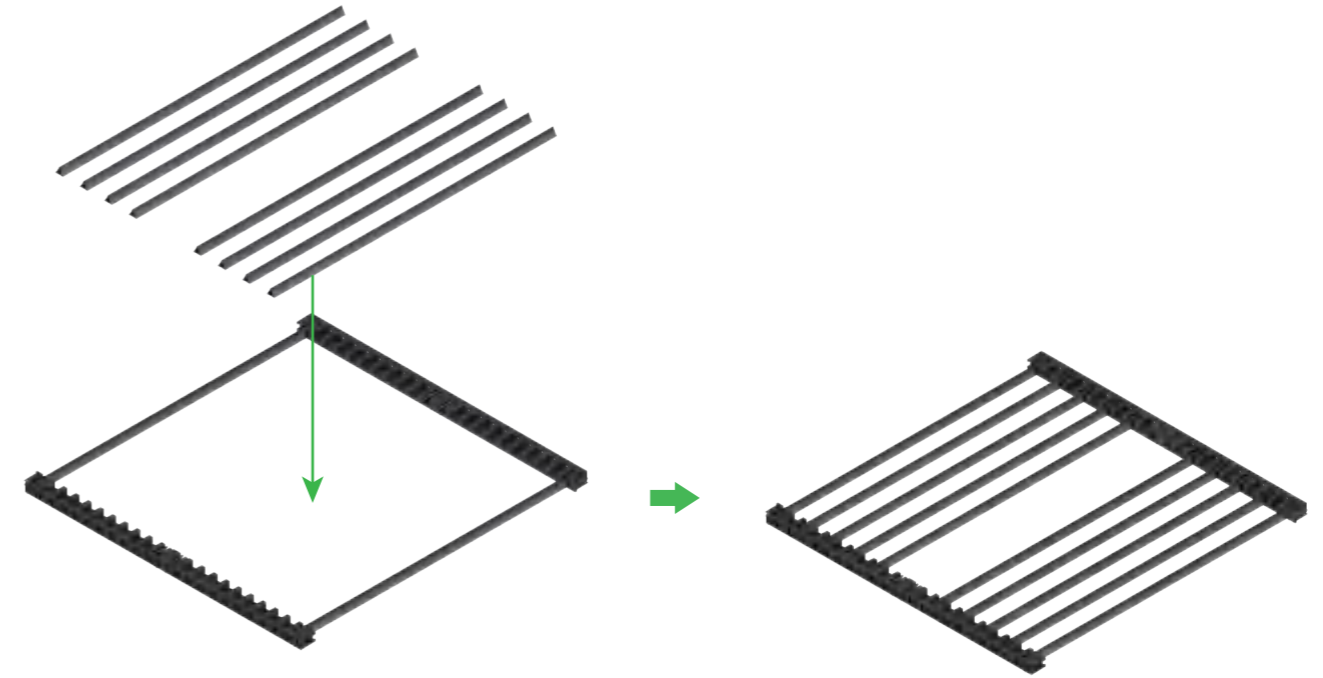
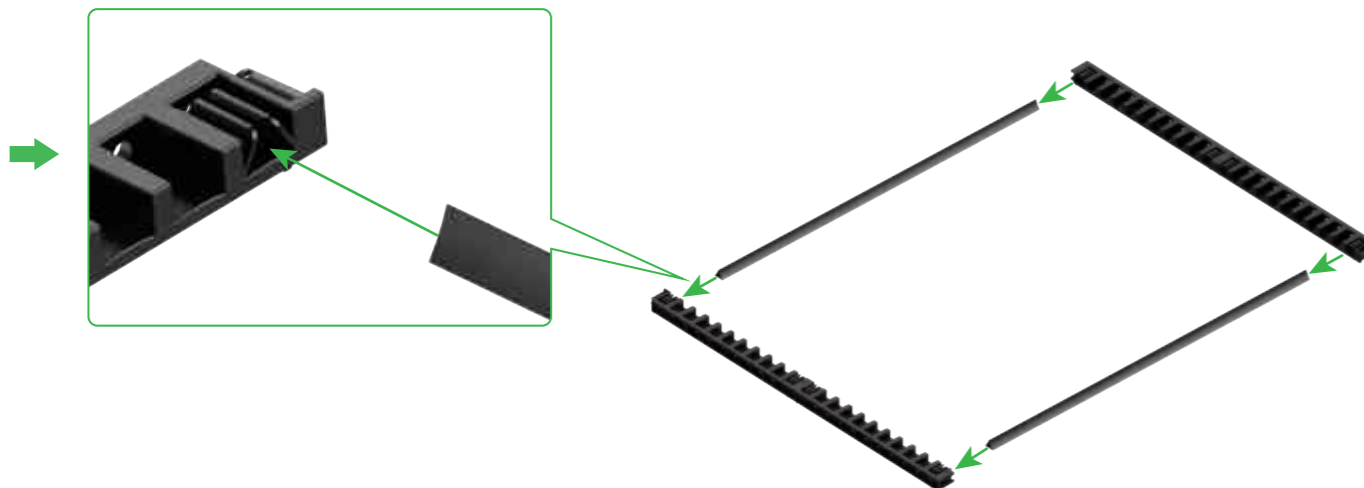

Determine the number of the triangular prisms based on the material to be processed.

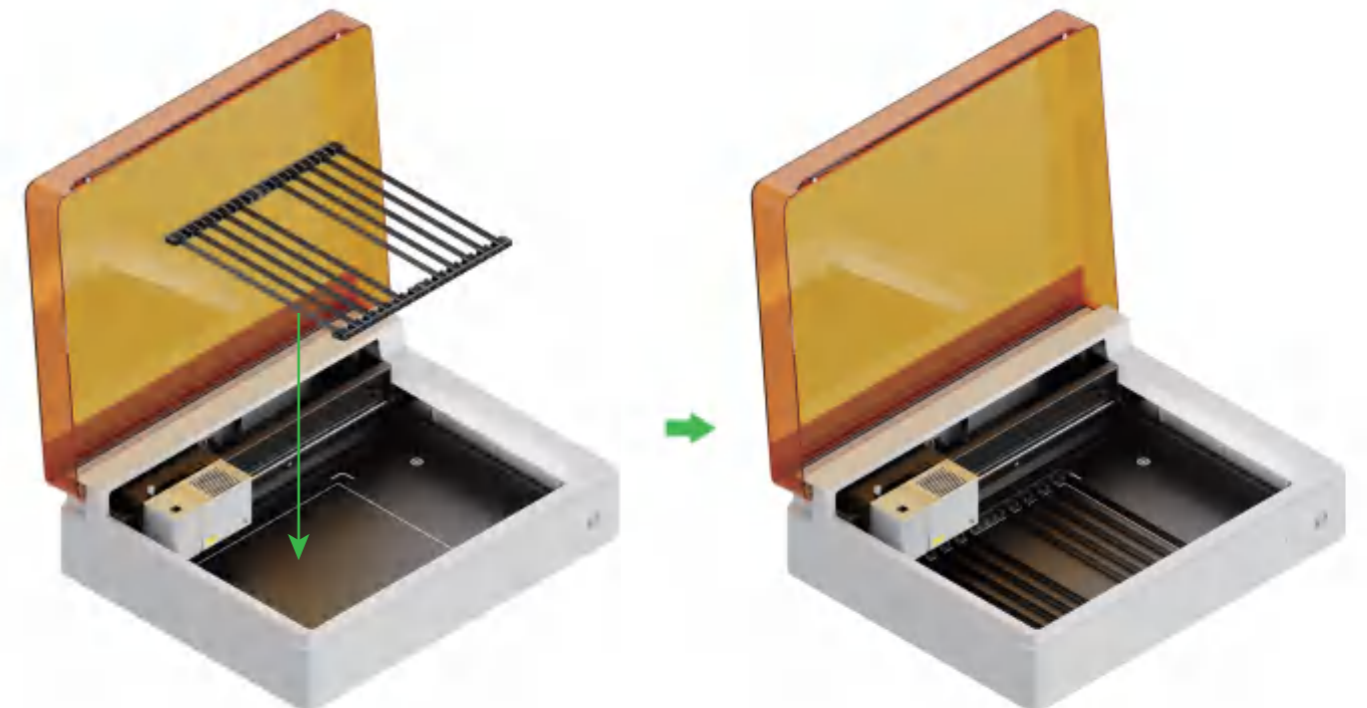

For blade cutting or combination of laser processing and blade cutting

1



Note: For paper materials such as cardboard and kraft paper, use the LightGrip cutting mat; and for fabric materials such as cloth, use the FabricGrip cutting mat.
Do not use any cutting mat when cutting a material with laser beams.

Cutting mat		
Color	Blue	Pink
Applicable to	Lightweight materials	Fabrics
Material	Cardboard, Wrapping paper, Printing paper Kraft paper, Pearl paper	Fabric

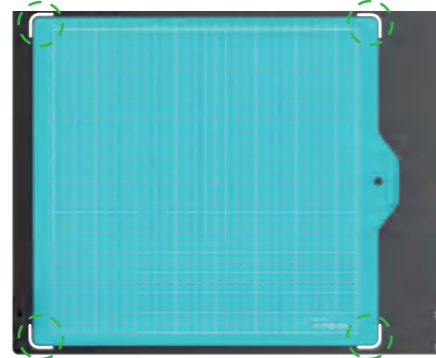
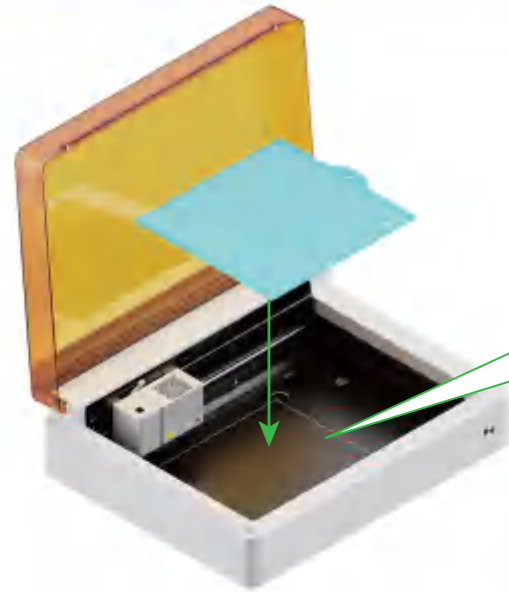

Remove the protective film before using the cutting mat.
When placing the cutting mat, align it with the markings in the four corners of the baseplate.



2

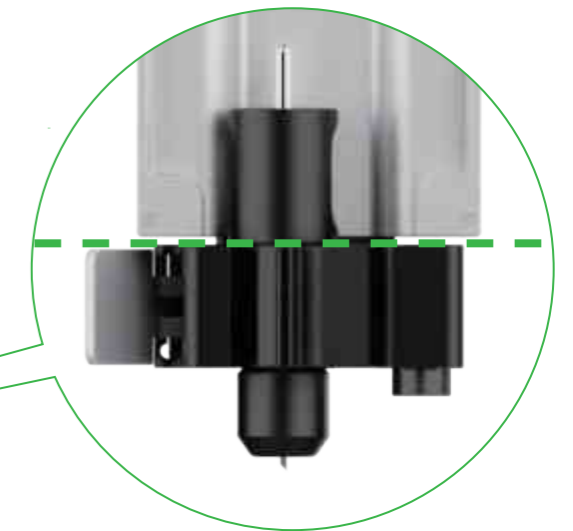
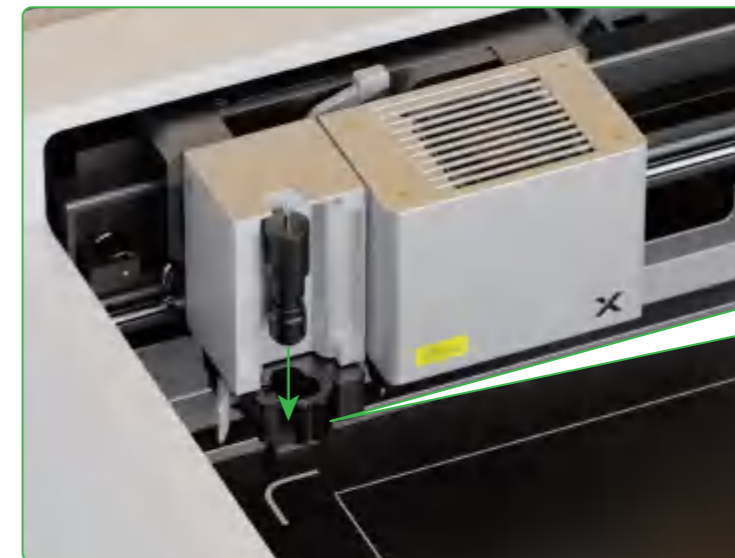
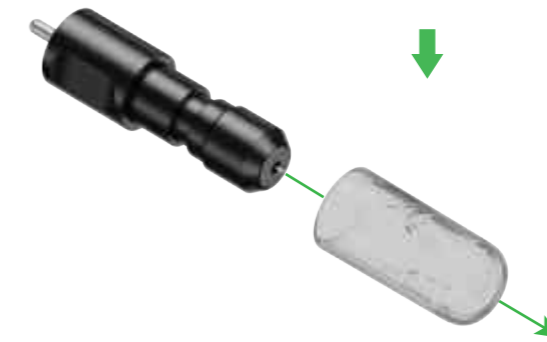
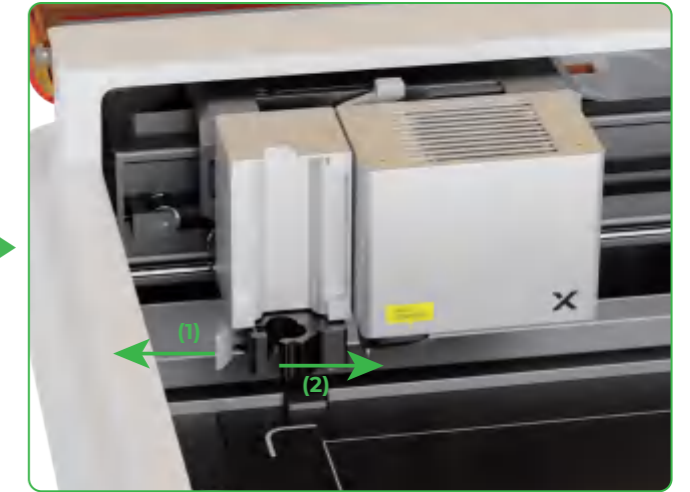
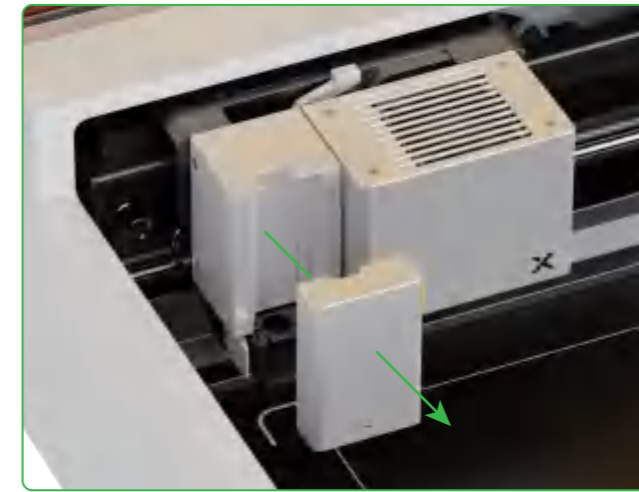

Caution!
Sharp blade

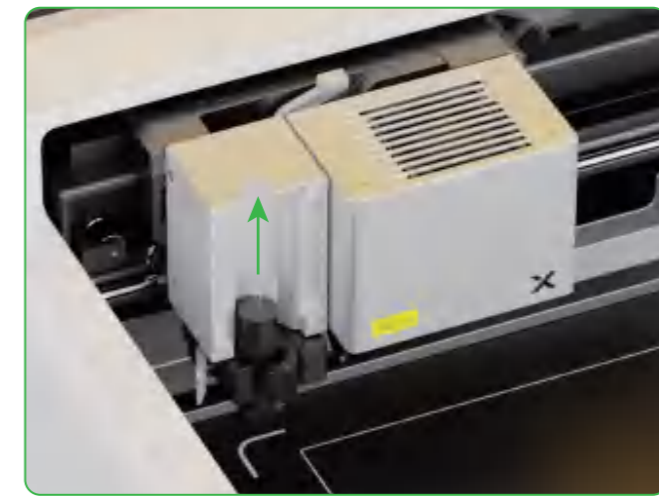
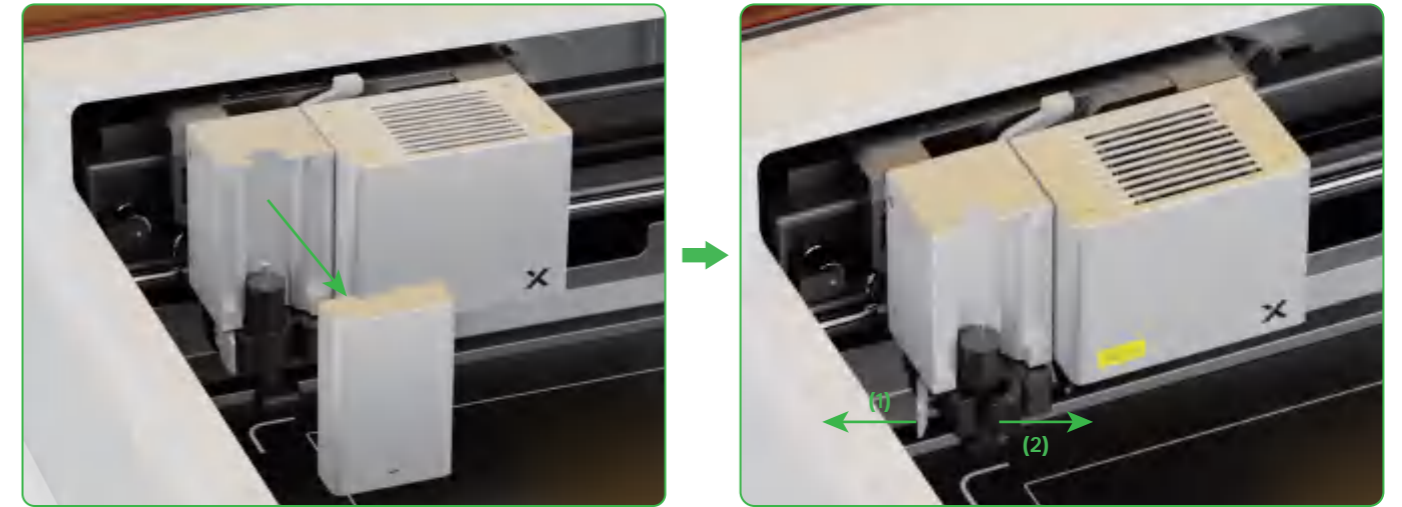
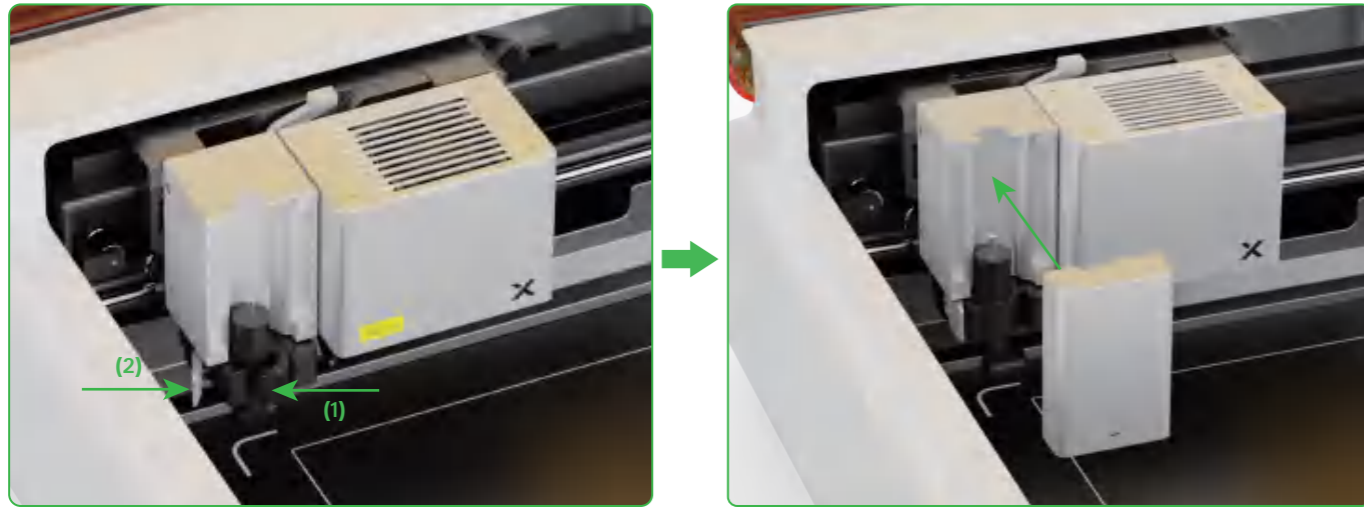

Caution!
Sharp blade

For pen drawing

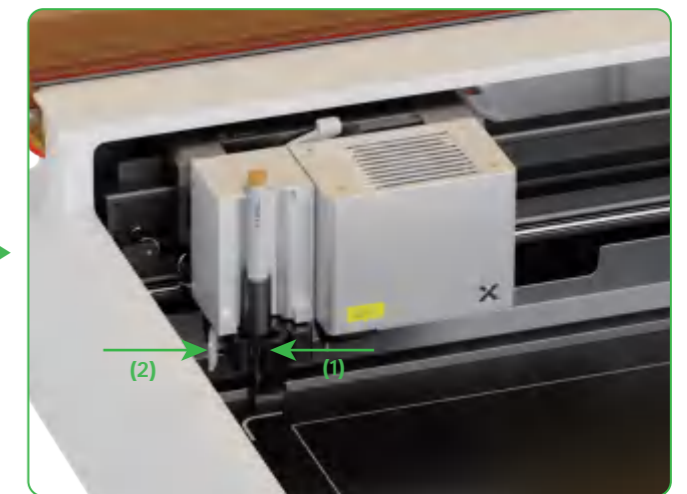
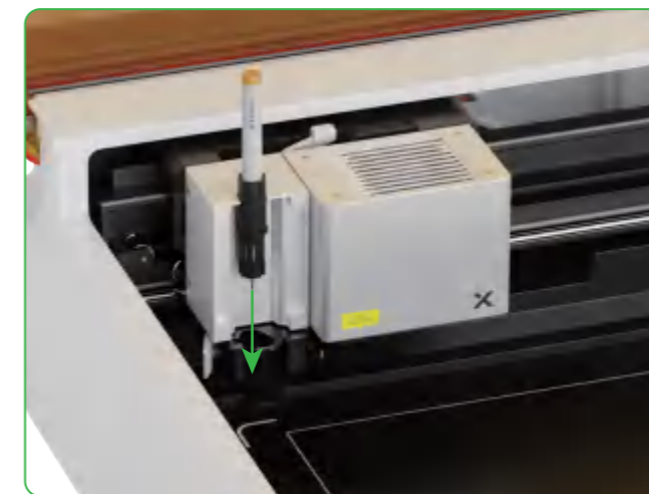



For more functions

 If the kit you've purchased does not include the multi-function carriage and its accessories, you can purchase them separately.

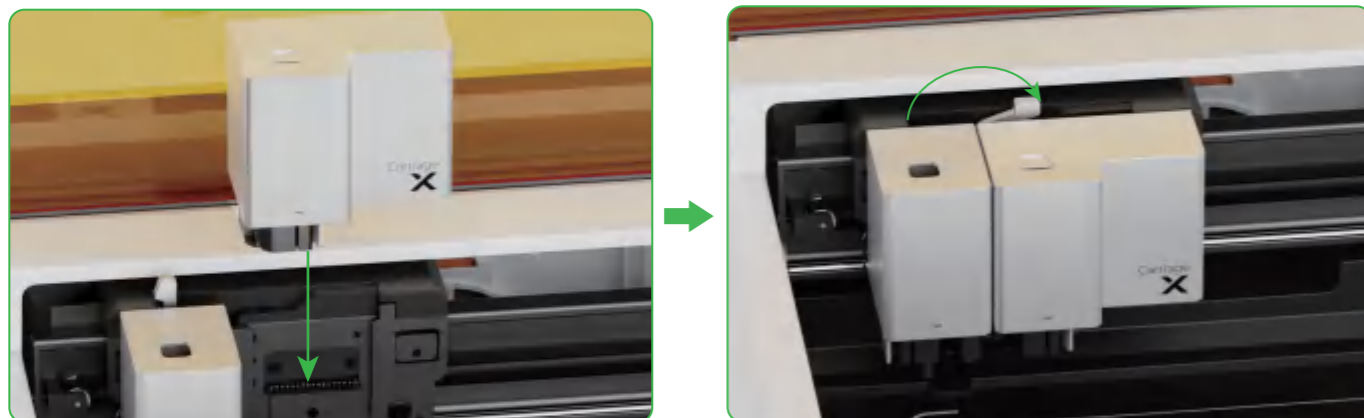
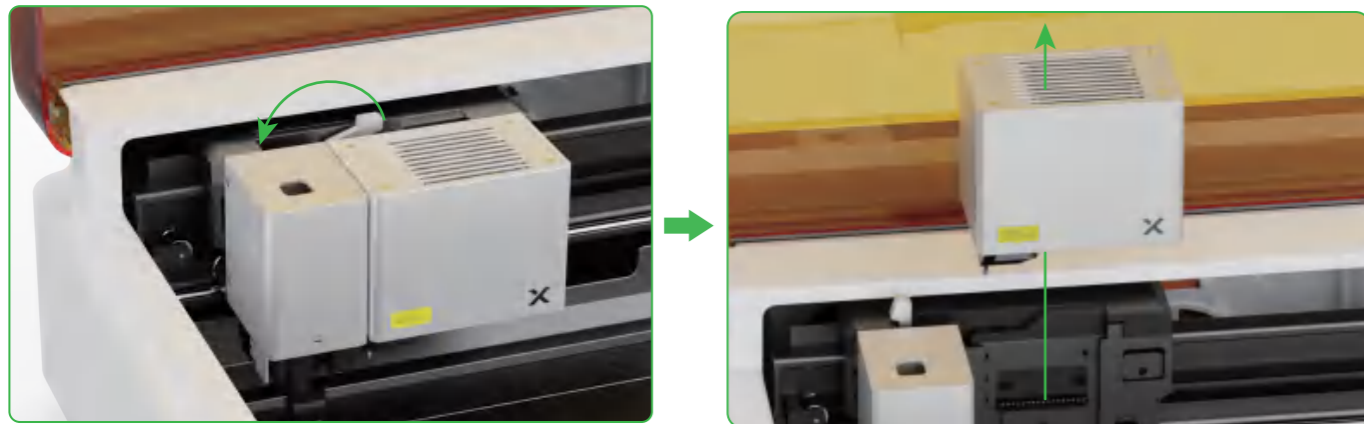

2

 Select accessories according to the processing needs.

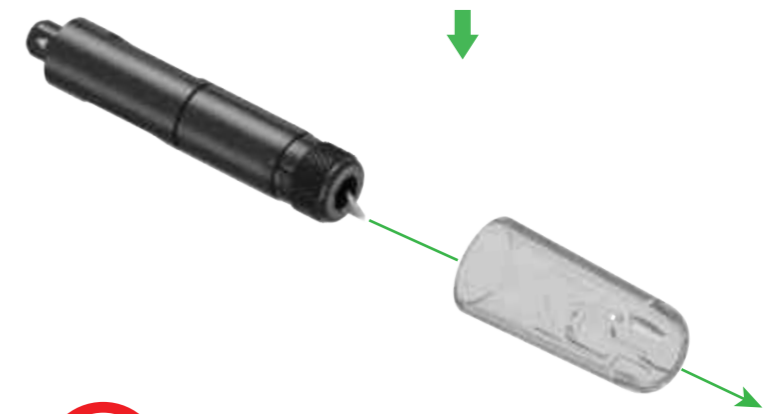
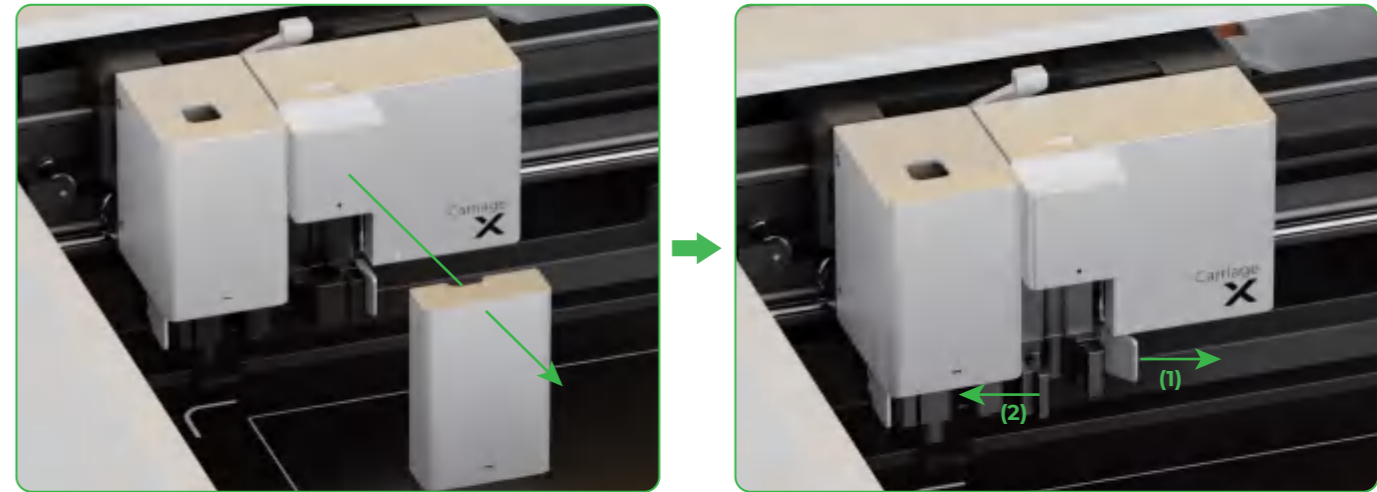

 Caution!
Sharp blade

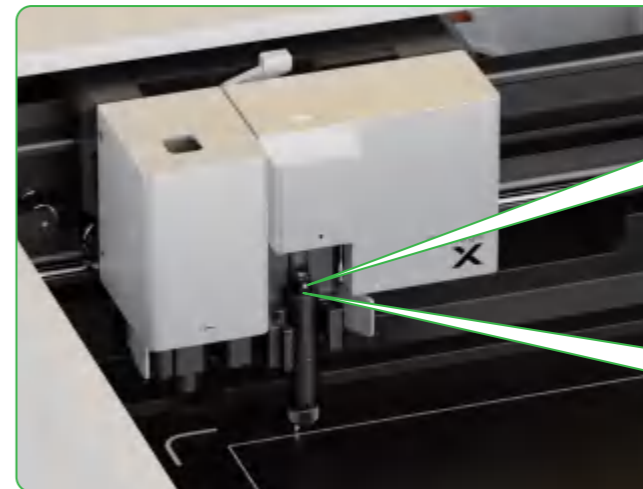

 Ensure that the sign faces you when fitting the cutting blade.

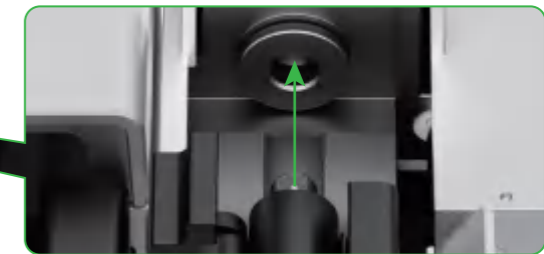

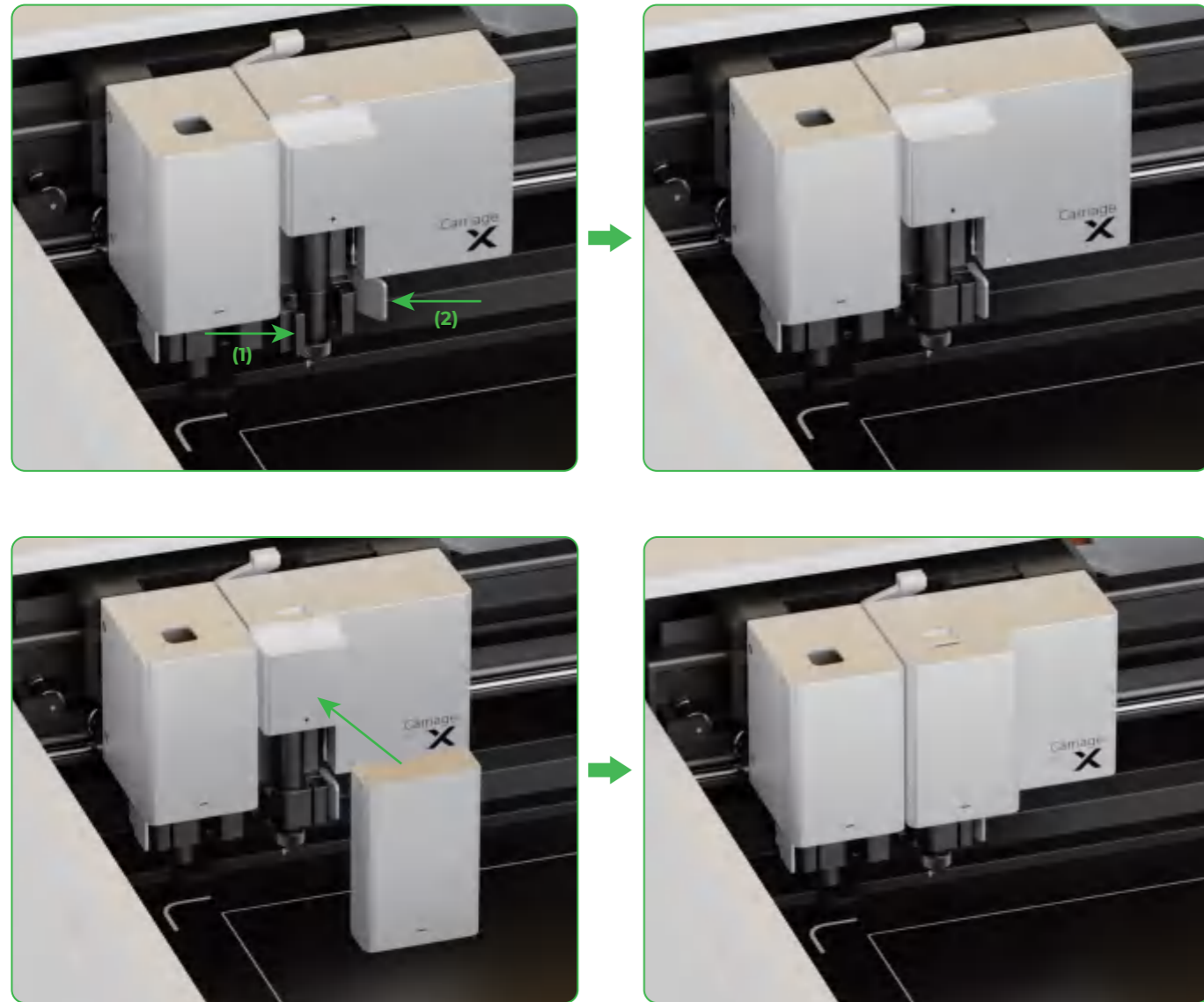

Indicator description

Indicator status	Buzzer status	Device status
Solid white	/	Standby, not connected to XCS
Solid purple	Sounding once	Standby, connected to XCS
Breathing white	/	Sleeping, not connected to XCS
Breathing purple	/	Sleeping, connected to XCS
Blinking purple slowly	/	Network setting / Firmware updating
Solid green	/	Processing area marking on XCS / Framing / Processing
Blinking blue slowly	Sounding once	Ready for framing / Ready to process
Solid blue	/	Task paused
Blinking yellow	Sounding once	The lid is open or not fully closed during operation.
Blinking yellow	Keeping sounding	Flame detected (small flame) / Device shaken
Blinking red	Keeping sounding	Flame detected (large flame)
Blinking yellow	Sounding three times	Exceptions occur
Blinking red	Sounding three times	Major exceptions occur

Maintenance

Replace the filter

13



Do not use the filter if it is moistened.



Replace the lens mount

18

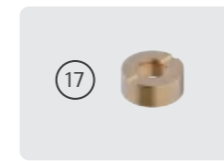
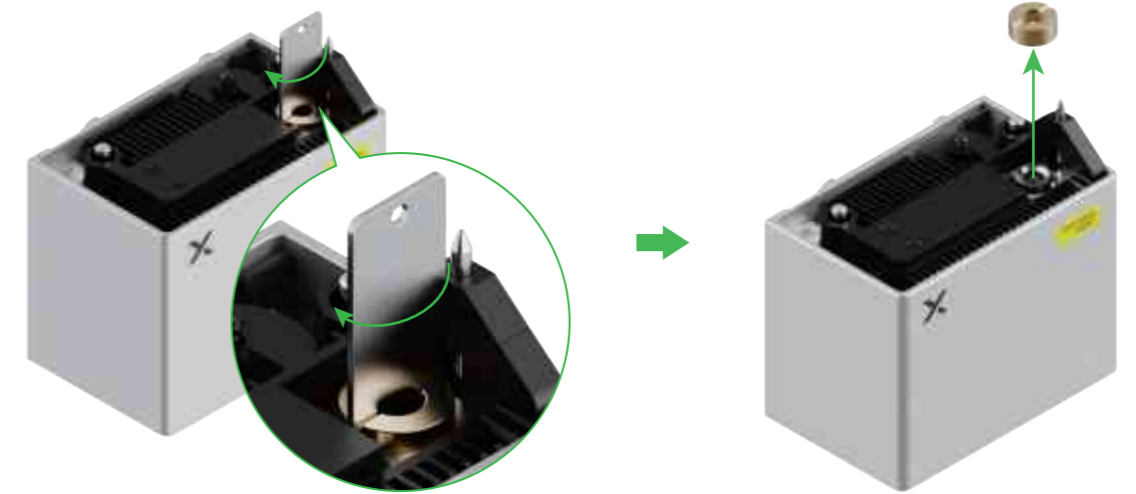
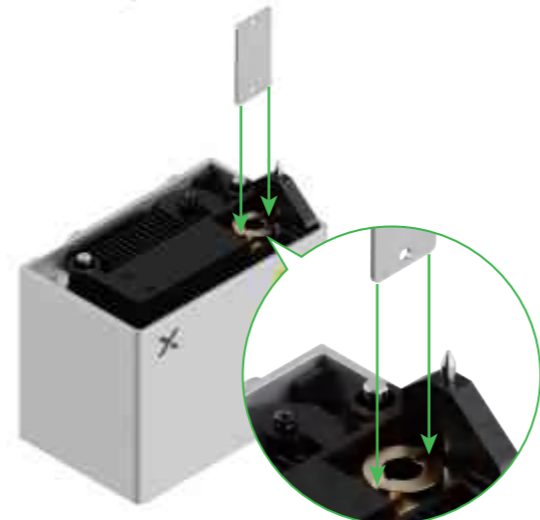
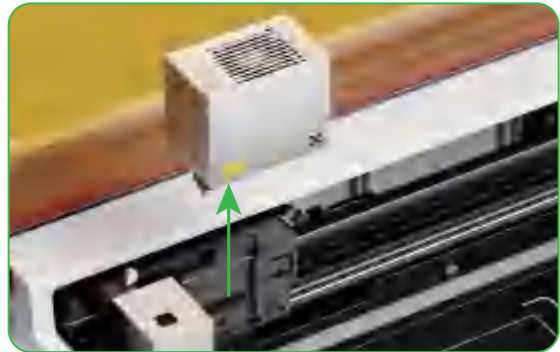

17

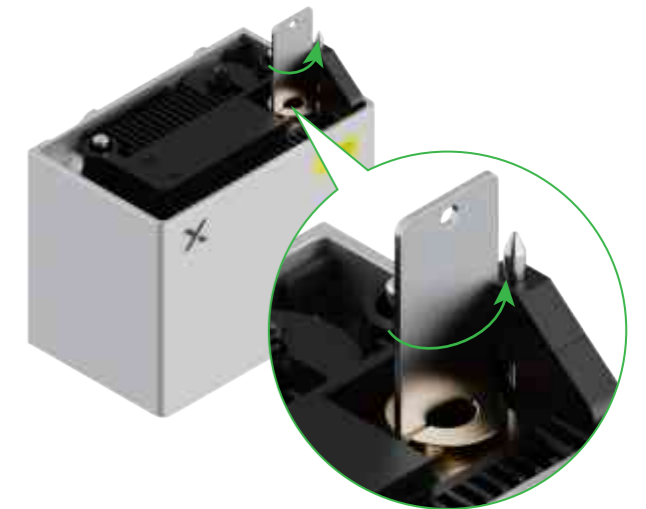
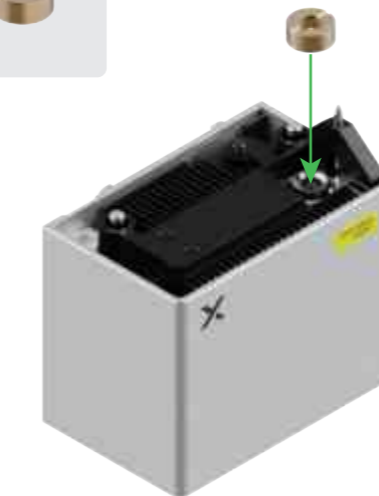

Clean the probe

The probe may get dirty after a long period of laser processing. Clean it in a timely manner, or the focusing accuracy may be reduced.

You are advised to clean the probe with a lint-free cloth moistened with alcohol.

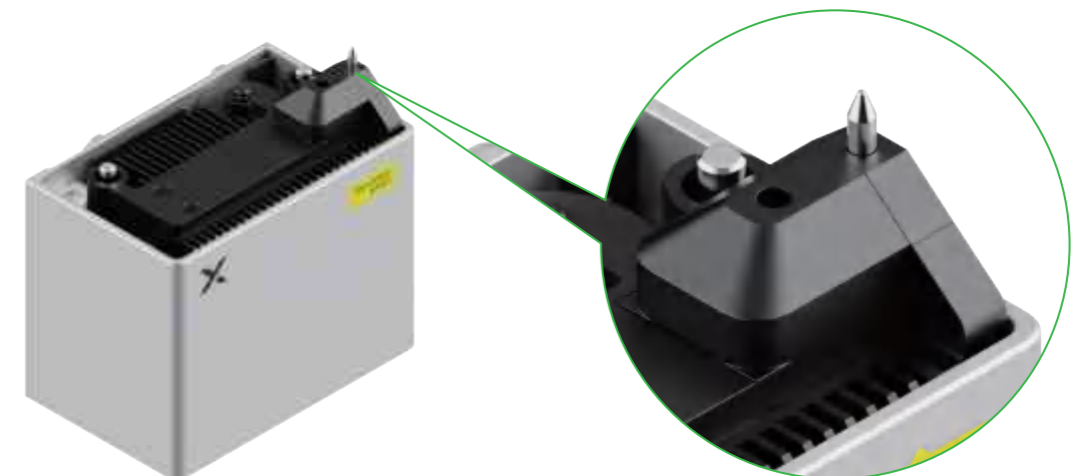

FAQs

1. The smoke exhaust module doesn't work during material processing. What can I do?

Possible causes:

Too much dust accumulates on the exhaust fan. / The filter gets blocked.

Solutions:

(1) Turn off xTool M2 and remove the smoke exhaust module.

(2) Replace the filter.

(3) Install the smoke exhaust module back to xTool M2.

Note: Ensure that you install the smoke exhaust module back to prevent laser leakage or fan contact.

2. The laser module / multi-function carriage doesn't work properly. Why?

Possible causes:

- The laser module / multi-function carriage is not installed properly.

- The locking bar above the laser module is not locked in place.

Solutions:

- Push the laser module / multi-function carriage down until you hear a click.

- After the laser module or multi-function carriage is fitted in place, toggle the locking bar to the right to lock it.

3. The baseplate or cutting mat is dirty due to long time processing. What can I do?

- Each time after you complete the processing, clean the baseplate or triangular prism with a cleaning cloth moistened with water and then dry it.

- If the baseplate is very dirty and hard to clean, wipe the dirt from it with a cleaning cloth moistened with absolute ethyl alcohol.

4. When do I need to replace the filter?

The replacement frequency varies according to material.

You need to replace the filter when:

- A pop-up window on XCS prompts you to replace the filter.

- The smoke and fumes accumulate a lot inside the device.

5. When I use an orange pen for processing, I can't see the lines drawn by the pen. Why?

Because the lid is orange.

Declaration of conformity

Hereby, Makeblock Co., Ltd., declares that this product is in compliance with the essential requirements and other relevant provisions of Directive RED 2014/53/EU and the RoHS directive 2011/65/EU.

FCC statement

This device complies with Part 15 of the FCC Rules.

Operation is subject to the following two conditions:

(1) This device may not cause harmful interference, and (2)

This device must accept any interference received, including interference that may cause undesired operation.

Warning: Changes or modifications not expressly approved by the party responsible for compliance could void the user's authority to operate the equipment.

NOTE: This equipment has been tested and found to comply with the limits for a Class B digital device, pursuant to Part 15 of the FCC Rules.

These limits are designed to provide reasonable protection against harmful interference in a residential installation. This equipment generates uses and can radiate radio frequency energy and, if not installed and used in accordance with the instructions, may cause harmful interference to radio communications. However, there is no guarantee that interference will not occur in a particular installation. If this equipment does cause harmful interference to radio or television reception, which can be determined by turning the equipment off and on, the user is encouraged to try to correct the interference by one or more of the following measures:

- Reorient or relocate the receiving antenna.

- Increase the separation between the equipment and receiver.

- Connect the equipment into an outlet on a circuit different from that to which the receiver is connected.

- Consult the dealer or an experienced radio/TV technician for help.

FCC Radiation Exposure Statement

This equipment complies with FCC radiation exposure limits set forth for an uncontrolled environment. This equipment should be installed and operated with minimum distance 20cm between the radiator & your body.

This device complies with Industry Canada licence-exempt RSS standard (s). Operation is subject to the following two conditions:

(1) this device may not cause interference, and (2) this device must accept any interference, including interference that may cause undesired operation of the device.

Le présent appareil est conforme aux CNR d'Industrie Canada applicables aux appareils radio exempts de licence. L'exploitation est autorisée aux deux conditions suivantes : (1) l'appareil nedoit pas produire de brouillage, et (2) l'utilisateur de l'appareil doit accepter tout brouillage radioélectrique subi, même si le brouillage est susceptible d'en compromettre le fonctionnement.

After-sales services

For technical support, contact us at support@xtool.com.

For more information about after-sales services, visit support.xtool.com.