

FCC Radio Test Report

FCC ID: 2AH4HATD600

This report concerns: Original Grant

Project No. : 2107C193
Equipment : LTE Cat-M1 Tracker
Brand Name : Mobilogix
Test Model : ATD600S
Series Model : N/A
Applicant : Mobilogix, Inc.
Address : 5500 Trabuco Rd Suite 150 Irvine, CA, USA
Manufacturer : Mobilogix, Inc.
Address : 5500 Trabuco Rd Suite 150 Irvine, CA, USA
Factory : Suga Electronics (Dongguan) Co., Ltd.
Address : No.8 Fulong Road, Qingxi Town, Dongguan City
Date of Receipt : Jul. 29, 2021
Date of Test : Jul. 30, 2021 ~ Sep. 10, 2021
Issued Date : Sep. 18, 2021
Report Version : R00
Test Sample : Engineering Sample No.: DG2021081225 for radiated, DG2021081224 for conducted.
Standard(s) : 47 CFR FCC Part 24 Subpart E
47 CFR FCC Part 2
ANSI/TIA/EIA-603-E-2016
FCC KDB 971168 D01 Power Meas License Digital Systems v03r01

The above equipment has been tested and found compliance with the requirement of the relative standards by BTL Inc.

Vegeta Li

Prepared by : Vegeta Li

Steven Lu

Approved by : Steven Lu



TESTING CERT #5123.02

Add: No. 3 Jinshagang 1st Rd. Shixia, Dalang Town, Dongguan City, Guangdong, People's Republic of China

Tel: +86-769-8318-3000

Web: www.newbtl.com

Declaration

BTL represents to the client that testing is done in accordance with standard procedures as applicable and that test instruments used has been calibrated with standards traceable to international standard(s) and/or national standard(s).

BTL's reports apply only to the specific samples tested under conditions. It is manufacture's responsibility to ensure that additional production units of this model are manufactured with the identical electrical and mechanical components. **BTL** shall have no liability for any declarations, inferences or generalizations drawn by the client or others from **BTL** issued reports.

The report must not be used by the client to claim product certification, approval, or endorsement by NIST, A2LA, or any agency of the U.S. Government.

This report is the confidential property of the client. As a mutual protection to the clients, the public and ourselves, the test report shall not be reproduced, except in full, without our written approval.

BTL's laboratory quality assurance procedures are in compliance with the **ISO/IEC 17025** requirements, and accredited by the conformity assessment authorities listed in this test report.

BTL is not responsible for the sampling stage, so the results only apply to the sample as received.

The information, data and test plan are provided by manufacturer which may affect the validity of results, so it is manufacturer's responsibility to ensure that the apparatus meets the essential requirements of applied standards and in all the possible configurations as representative of its intended use.

Limitation

For the use of the authority's logo is limited unless the Test Standard(s)/Scope(s)/Item(s) mentioned in this test report is (are) included in the conformity assessment authorities acceptance respective.

Please note that the measurement uncertainty is provided for informational purpose only and is not use in determining the Pass/Fail results.

Table of Contents**Page**

REPORT ISSUED HISTORY	5
1 . SUMMARY OF TEST RESULTS	6
1.1 TEST FACILITY	7
1.2 MEASUREMENT UNCERTAINTY	7
1.3 TEST ENVIRONMENT CONDITIONS	7
2 . GENERAL INFORMATION	8
2.1 GENERAL DESCRIPTION OF EUT	8
2.2 DESCRIPTION OF TEST MODES	9
2.3 BLOCK DIAGRAM SHOWING THE CONFIGURATION OF SYSTEM TESTED	10
2.4 DESCRIPTION OF SUPPORT UNITS	10
3 . TEST RESULT	11
3.1 OUTPUT POWER MEASUREMENT	11
3.1.1 LIMIT	11
3.1.2 TEST PROCEDURE	11
3.1.3 TEST SETUP LAYOUT	11
3.1.4 TEST DEVIATION	11
3.1.5 TEST RESULTS	11
3.2 OCCUPIED BANDWIDTH MEASUREMENT	12
3.2.1 TEST PROCEDURE	12
3.2.2 TEST SETUP LAYOUT	12
3.2.3 TEST DEVIATION	12
3.2.4 TEST RESULTS	12
3.3 CONDUCTED SPURIOUS EMISSIONS MEASUREMENT	13
3.3.1 LIMIT	13
3.3.2 TEST PROCEDURES	13
3.3.3 TEST SETUP LAYOUT	13
3.3.4 TEST DEVIATION	13
3.3.5 TEST RESULTS	13
3.4 RADIATED SPURIOUS EMISSIONS MEASUREMENT	14
3.4.1 LIMIT	14
3.4.2 TEST PROCEDURES	14
3.4.3 TEST SETUP LAYOUT	15
3.4.4 TEST DEVIATION	16
3.4.5 TEST RESULTS (9KHZ TO 30MHZ)	16
3.4.6 TEST RESULTS (30MHZ TO 1000MHZ)	16
3.4.7 TEST RESULTS (ABOVE 1000MHZ)	16
3.5 BAND EDGE MEASUREMENT	17
3.5.1 LIMIT	17
3.5.2 TEST PROCEDURES	17

Table of Contents	Page
3.5.3 TEST SETUP LAYOUT	17
3.5.4 TEST DEVIATION	17
3.5.5 TEST RESULTS	17
3.6 PEAK TO AVERAGE RATIO MEASUREMENT	18
3.6.1 LIMIT	18
3.6.2 TEST PROCEDURES	18
3.6.3 TEST SETUP LAYOUT	18
3.6.4 TEST DEVIATION	18
3.6.5 TEST RESULTS	18
3.7 FREQUENCY STABILITY MEASUREMENT	19
3.7.1 LIMIT	19
3.7.2 TEST PROCEDURES	19
3.7.3 TEST SETUP LAYOUT	19
3.7.4 TEST DEVIATION	19
3.7.5 TEST RESULTS	19
4. LIST OF MEASUREMENT EQUIPMENTS	20
APPENDIX A - OUTPUT POWER	22
APPENDIX B - OCCUPIED BANDWIDTH	24
APPENDIX C - CONDUCTED SPURIOUS EMISSIONS	35
APPENDIX D - RADIATED SPURIOUS EMISSIONS (9KHZ TO 30MHZ)	44
APPENDIX E - RADIATED SPURIOUS EMISSIONS (30MHZ TO 1000MHZ)	49
APPENDIX F - RADIATED SPURIOUS EMISSIONS (ABOVE 1000MHZ)	66
APPENDIX G - BAND EDGE	83
APPENDIX H - PEAK TO AVERAGE RATIO	90
APPENDIX I - FREQUENCY STABILITY	95

REPORT ISSUED HISTORY

Report Version	Description	Issued Date
R00	Original Issue.	Sep. 18, 2021

1. SUMMARY OF TEST RESULTS

Test procedures according to the technical standard(s):

FCC Part 24 Subpart E & Part 2			
Standard(s) Section	Test Item	Judgment	Remark
2.1046 24.232(c)	Output Power & Equivalent Isotropic Radiated Power	PASS	-----
2.1049	Occupied Bandwidth	PASS	-----
2.1051 24.238(a)	Conducted Spurious Emissions	PASS	-----
2.1053 24.238(a)	Radiated Spurious Emissions	PASS	-----
24.238(a)	Band Edge Measurements	PASS	-----
24.232(d)	Peak To Average Ratio	PASS	-----
2.1055 24.235	Frequency Stability	PASS	-----

Note:

(1) "N/A" denotes test is not applicable in this test report.

1.1 TEST FACILITY

The test facilities used to collect the test data in this report is at the location of No. 3 Jinshagang 1st Rd. Shixia, Dalang Town, Dongguan City, Guangdong, People's Republic of China.

BTL's Test Firm Registration Number for FCC: 357015

BTL's Designation Number for FCC: CN1240

1.2 MEASUREMENT UNCERTAINTY

ISO/IEC 17025 requires that an estimate of the measurement uncertainties associated with the emissions test results be included in the report. The measurement uncertainties given below are based on a 95% confidence level (based on a coverage factor (k=2))

The BTL measurement uncertainty as below table:

A. Radiated Measurement:

Test Site	Method	Measurement Frequency Range	Ant. H / V	U, (dB)
DG-CB03	CISPR	9kHz ~ 30MHz	-	2.36
		30MHz ~ 200MHz	V	4.36
		30MHz ~ 200MHz	H	3.32
		200MHz ~ 1,000MHz	V	4.08
		200MHz ~ 1,000MHz	H	3.96
		1GHz ~ 6GHz	-	3.80
		6GHz ~ 18GHz	-	4.82

B. Other Measurement:

Parameter	Uncertainty
Spectrum Bandwidth	±3.8 %
Maximum Output Power	±0.95 dB
Power Spectral Density	±0.86 dB
Frequency Stability	±0.16 dB
Temperature	±0.08 °C
Time	±0.58 %
Supply voltages	±0.3 %

Note: Unless specifically mentioned, the uncertainty of measurement has not been taken into account to declare the compliance or non-compliance to the specification.

1.3 TEST ENVIRONMENT CONDITIONS

Test Item	Temperature	Humidity	Test Voltage	Tested By
Output Power & EIRP	23.5°C	43%	DC 3.6 V	Tate Liu
Occupied Bandwidth	23.5°C	43%	DC 3.6 V	Tate Liu
Conducted Spurious Emissions	23.5°C	43%	DC 3.6 V	Tim Yang
Radiated Spurious Emissions	26°C	52%	DC 3.6 V	Kwok Guo
Band Edge	23.5°C	43%	DC 3.6 V	Tate Liu
Peak to Average Ratio	23.5°C	43%	DC 3.6 V	Tate Liu
Frequency Stability	Normal & Extreme	43%	Normal & Extreme	Tate Liu

2. GENERAL INFORMATION

2.1 GENERAL DESCRIPTION OF EUT

Equipment	LTE Cat-M1 Tracker			
Brand Name	Mobilogix			
Test Model	ATD600S			
Series Model	N/A			
Model Difference(s)	N/A			
Hardware Version	1.1			
Software Version	1.1.45			
Power Source	Supplied from battery.			
Power Rating	DC 3.6V			
IEMI No.	Conducted	867730051961021		
	Radiated	867730051961708		
Category	NB2			
Sub-carrier Spacing	3.75KHz, 15KHz			
Modulation Type	UL: BPSK, QPSK DL: BPSK, QPSK			
Max. EIRP	LTE	Sub-carrier Spacing (kHz)	BPSK (dBm)	QPSK (dBm)
	Band 2	3.75	22.96	23.04
		15	23.60	23.78
	Band 25	3.75	23.64	23.64
		15	23.72	23.90

Note:

- For a more detailed features description, please refer to the manufacturer's specifications or the user's manual.

2. Table for Filed Antenna:

Brand	P/N	Antenna Type	Connector	Gain (dBi)	Note
ethertronics	1004795	Chip	N/A	3.1	LTE Band 2
ethertronics	1004795	Chip	N/A	3.1	LTE Band 25

Note: The antenna gain is provided by the manufacturer.

2.2 DESCRIPTION OF TEST MODES

Following mode(s) is (were) found to be the worst case(s) and selected for the final test.

LTE Band 2 MODE				
Test Item	Tested Channel	Sub-carrier Spacing(kHz)	Modulation	Mode
Output Power & EIRP	18601, 18900, 19199	3.75	BPSK, QPSK	1RB
		15		
Occupied Bandwidth	18601, 18900, 19199	3.75	BPSK, QPSK	1RB
		15		1RB/12RB
Conducted Spurious Emissions	18900	3.75	BPSK, QPSK	1RB
		15		
Radiated Spurious Emissions	18900	3.75	BPSK, QPSK	1RB
		15		
Band Edge	18602, 19198	3.75	BPSK, QPSK	1RB
		15		1RB/12RB
Peak To Average Ratio	18601, 18900, 19199	3.75	BPSK, QPSK	1RB
		15		
Frequency Stability	18900	3.75	BPSK, QPSK	1RB
		15		

LTE Band 25 MODE				
Test Item	Tested Channel	Sub-carrier Spacing(kHz)	Modulation	Mode
Output Power & EIRP	26041, 26365, 26689	3.75	BPSK, QPSK	1RB
		15		
Occupied Bandwidth	26041, 26365, 26689	3.75	BPSK, QPSK	1RB
		15		1RB/12RB
Conducted Spurious Emissions	26365	3.75	BPSK, QPSK	1RB
		15		
Radiated Spurious Emissions	26365	3.75	BPSK, QPSK	1RB
		15		
Band Edge	26042, 26688	3.75	BPSK, QPSK	1RB
		15		1RB/12RB
Peak To Average Ratio	26041, 26365, 26689	3.75	BPSK, QPSK	1RB
		15		
Frequency Stability	26365	3.75	BPSK, QPSK	1RB
		15		

2.3 BLOCKDIGRAMSHOWINGTHECONFIGURATIONOFSYSTEMTESTED**2.4 DESCRIPTION OF SUPPORT UNITS**

The EUT has been tested as an independent unit together with other necessary accessories or support units. The following support units or accessories were used to form a representative test configuration during the tests.

Item	Equipment	Brand	Model No.	Series No.
-	-	-	-	-

Item	Cable Type	Shielded Type	Ferrite Core	Length
-	-	-	-	-

3. TEST RESULT

3.1 OUTPUT POWER MEASUREMENT

3.1.1 LIMIT

Mobile / Portable station are limited to 2 watts e.i.r.p.

3.1.2 TEST PROCEDURE

The testing follows FCC KDB 971168 v03r01 Section 5.

EIRP:

$EIRP = \text{Output Power} + \text{Antenan gain}$

Output Power:

The EUT was set up for the maximum power with GSM, GPRS, EDGE, WCDMA and LTE link data modulation and link up with simulator. Set the EUT to transmit under low, middle and high channel and record the power level shown on simulator.

3.1.3 TEST SETUP LAYOUT

Output Power Measurement

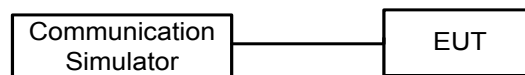

3.1.4 TEST DEVIATION

No deviation

3.1.5 TEST RESULTS

Please refer to the APPENDIX A.

3.2 OCCUPIED BANDWIDTH MEASUREMENT

3.2.1 TEST PROCEDURE

The testing follows FCC KDB 971168 v03r01 Section 4.

1. The EUT makes a call to the communication simulator. All measurements were done at low, middle and high operational frequency range. The communication simulator station system controlled a EUT to export maximum output power under transmission mode and specific channel frequency. Use OBW measurement function of Spectrum analyzer to measure 99 % occupied bandwidth and 26dB bandwidth.
2. The EUT was connected to spectrum analyzer and system simulator via a power divider.
3. $RBW=(1\% \sim 5\%)*EBW$
 $VBW \geq 3* RBW$
4. Set spectrum analyzer with Peak detector.

3.2.2 TEST SETUP LAYOUT

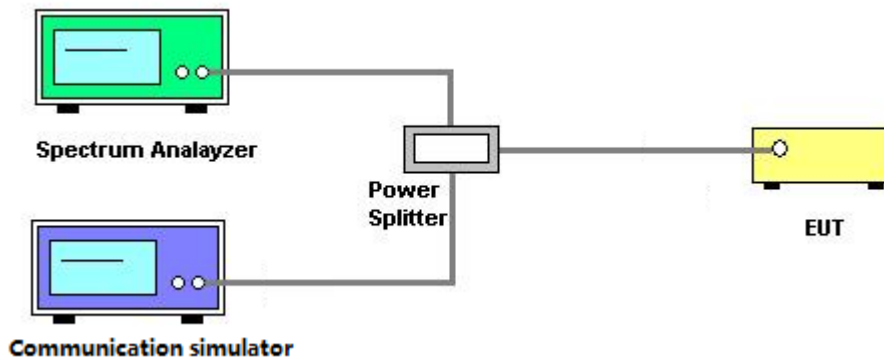

3.2.3 TEST DEVIATION

No deviation

3.2.4 TEST RESULTS

Please refer to the APPENDIX B.

3.3 CONDUCTED SPURIOUS EMISSIONS MEASUREMENT

3.3.1 LIMIT

The power of any emission outside of the authorized operating frequency ranges must be attenuated below the transmitting power (P) by a factor of at least $43 + 10 \log(P)$ dB. The emission limit equal to -13dBm.

3.3.2 TEST PROCEDURES

The testing follows FCC KDB 971168 v03r01 Section 6.

1. The EUT was connected to spectrum analyzer and system simulator via a power divider.
2. The band edges of low and high channels for the highest RF powers were measured. Set RBW $\geq 1\%$ EBW in the 1MHz band immediately outside and adjacent to the band edge.
3. Set spectrum analyzer with Peak detector.
4. The RF fundamental frequency should be excluded against the limit line in the operating frequency band.

3.3.3 TEST SETUP LAYOUT

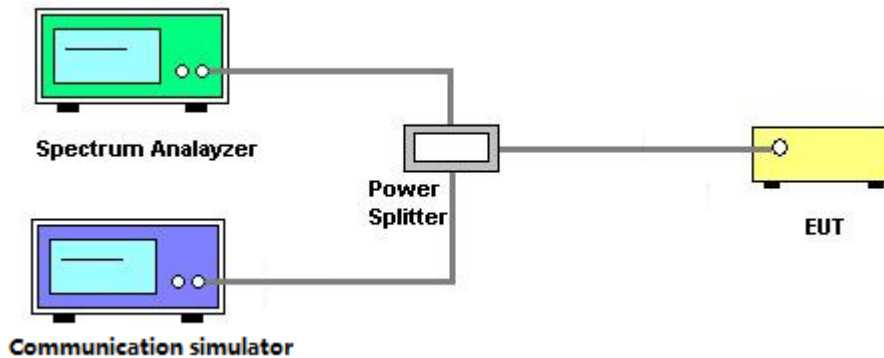

3.3.4 TEST DEVIATION

No deviation

3.3.5 TEST RESULTS

Please refer to the APPENDIX C.

3.4 RADIATED SPURIOUS EMISSIONS MEASUREMENT

3.4.1 LIMIT

The power of any emission outside of the authorized operating frequency ranges must be attenuated below the transmitting power (P) by a factor of at least $43 + 10 \log(P)$ dB. The emission limit equal to -13dBm.

3.4.2 TEST PROCEDURES

The testing follows FCC KDB 971168 v03r01 Section 6.2.

1. In the semi-anechoic chamber, EUT placed on the 0.8m height of Turn Table, rotated the table around 360 degrees to search the maximum radiation power and receiver antenna shall be rotated vertical and horizontal polarization and moved height from 1m to 4m to find the maximum polar radiated power. The "Read Value" is the spectrum reading the maximum power value.
2. The substitution horn antenna is substituted for EUT at the same position and signals generator export the CW signal to the substitution antenna via a TX cable. Rotated the Turn Table and moved receiving antenna to find the maximum radiation power. Adjust output power level of S.G to get a Value of spectrum reading equal to "Read Value " of step a. Record the power level of S.G
3. $EIRP = \text{Output power level of S.G} - \text{TX cable loss} + \text{Antenna gain of substitution horn.}$
4. ERP can be calculated form $EIRP$ by subtracting the gain of dipole, $ERP = EIPR - 2.15\text{dBi.}$
5. The resolution bandwidth and video bandwidth of test receiver/spectrum analyzer is 1MHz/3MHz.

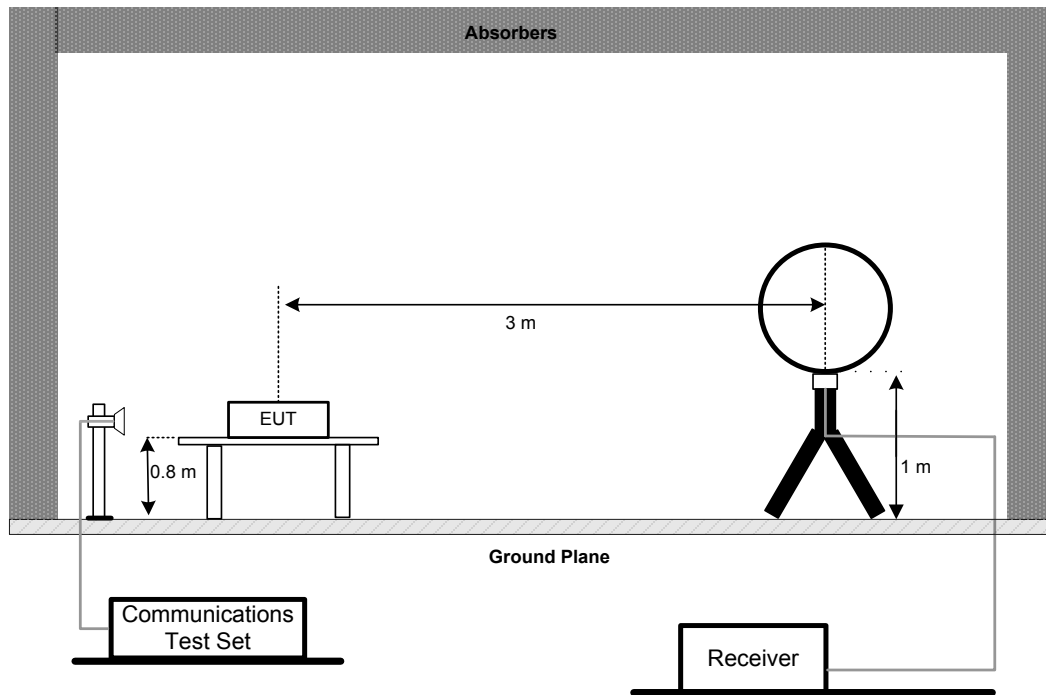
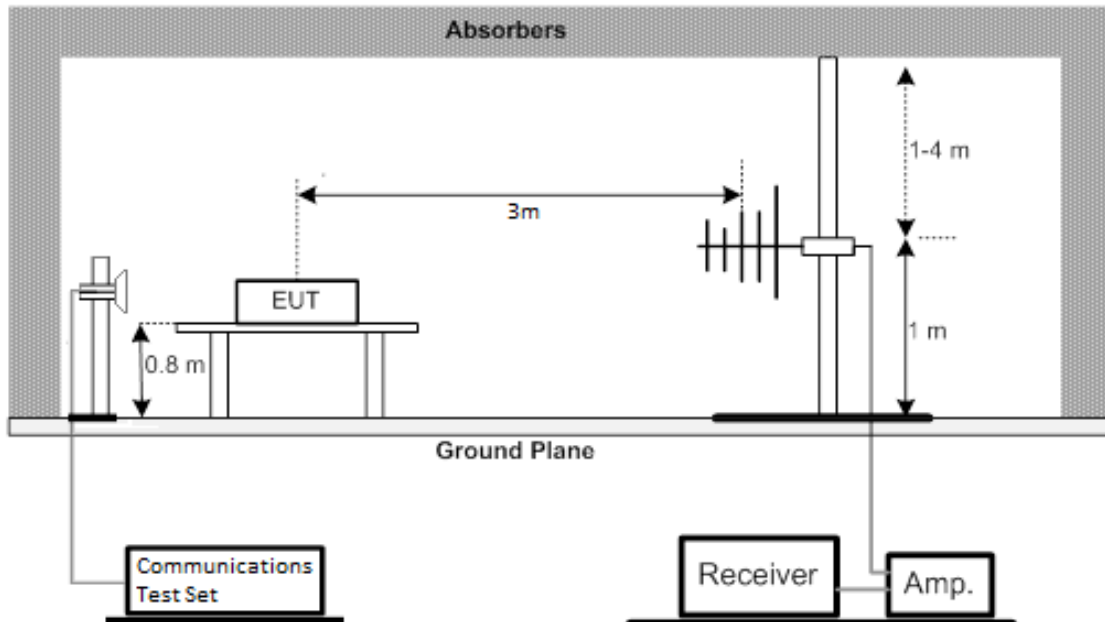
3.4.3 TEST SETUP LAYOUT**Below 30MHz****30MHz to 1000MHz**

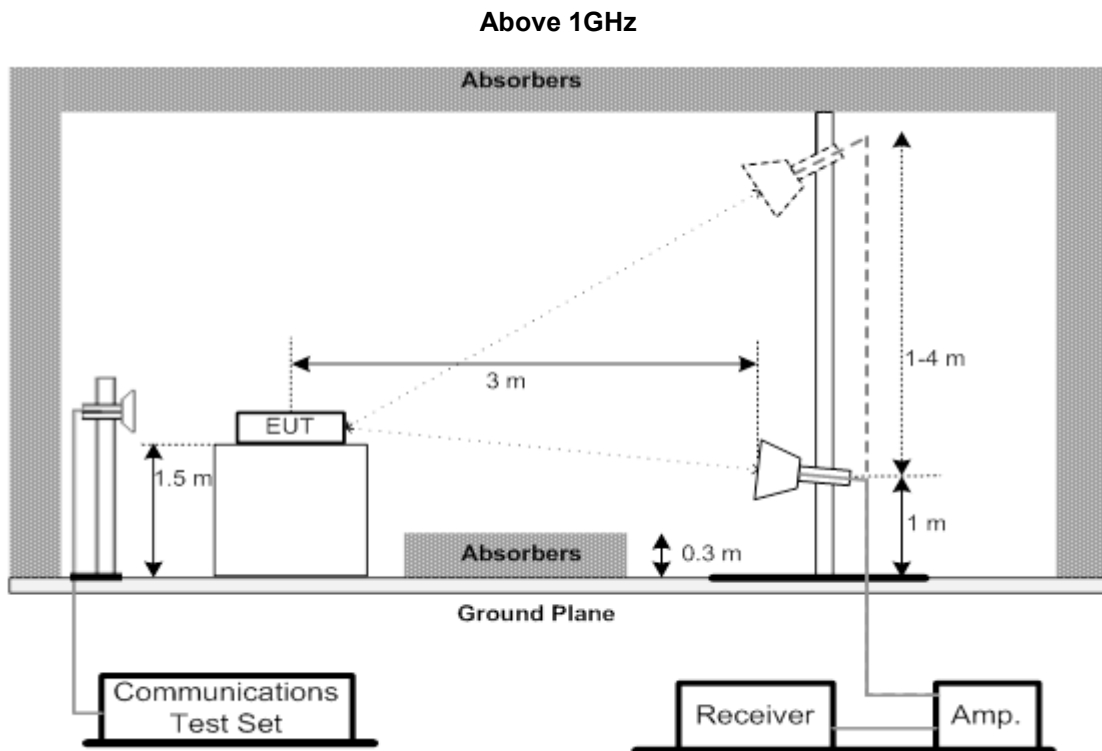

3.4.4 TEST DEVIATION

No deviation

3.4.5 TEST RESULTS (9KHZ TO 30MHZ)

Please refer to the APPENDIX D.

3.4.6 TEST RESULTS (30MHZ TO 1000MHZ)

Please refer to the APPENDIX E.

3.4.7 TEST RESULTS (ABOVE 1000MHZ)

Please refer to the APPENDIX F.

3.5 BAND EDGE MEASUREMENT

3.5.1 LIMIT

A Power of any emission outside of the authorized operating frequency ranges must be attenuated below the transmitting power (P) by a factor of at least $43 + 10 \log(P)$ dB. In the 1 MHz bands immediately outside and adjacent to the frequency block a resolution bandwidth of at least one percent of the emission bandwidth of the fundamental emission of the transmitter may be employed.

3.5.2 TEST PROCEDURES

The testing follows FCC KDB 971168 v03r01 Section 6.

1. All measurements were done at low and high operational frequency range.
2. Record the max trace plot into the test report.

3.5.3 TEST SETUP LAYOUT

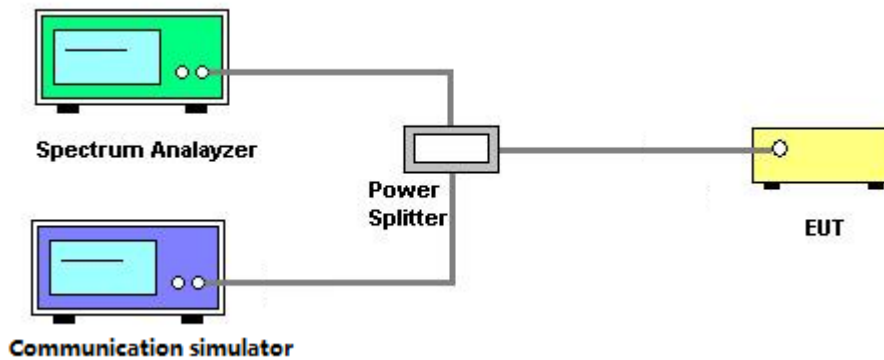

3.5.4 TEST DEVIATION

No deviation

3.5.5 TEST RESULTS

Please refer to the APPENDIX G.

3.6 PEAK TO AVERAGE RATIO MEASUREMENT

3.6.1 LIMIT

In measuring transmissions in this band using an average power technique, the peak to-average ratio (PAR) of the transmission may not exceed 13 dB.

3.6.2 TEST PROCEDURES

The testing follows FCC KDB 971168 v03r01 Section 5.7.

1. Set resolution/measurement bandwidth \geq signal's occupied bandwidth;
2. Set the number of counts to a value that stabilizes the measured CCDF curve;
3. Record the maximum PAPR level associated with a probability of 0.1%.

3.6.3 TEST SETUP LAYOUT

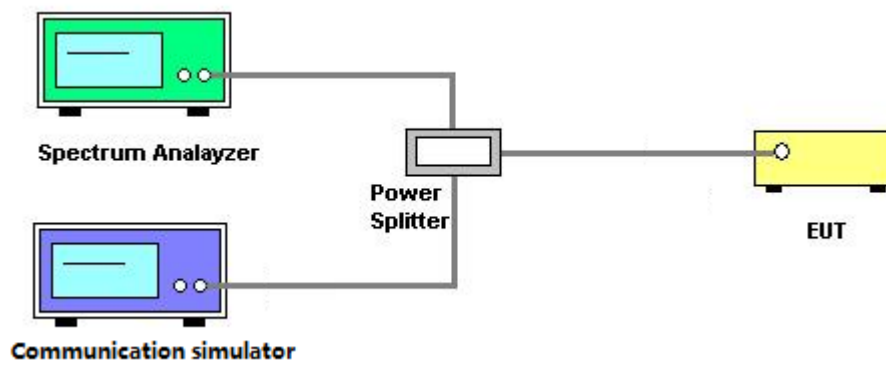

3.6.4 TEST DEVIATION

No deviation

3.6.5 TEST RESULTS

Please refer to the APPENDIX H.

3.7 FREQUENCY STABILITY MEASUREMENT

3.7.1 LIMIT

± 1.5 ppm is for base and fixed station. ± 2.5 ppm is for mobile station.

3.7.2 TEST PROCEDURES

The testing follows FCC KDB 971168 v03r01 Section 9.

1. Device is placed at the oven room. The oven room could control the temperatures and humidity. Power warm up is at least 15 min and power applied should perform before recording frequency error.
2. EUT is connected the external power supply to control the DC input power. The test voltage range is from minimum to maximum working voltage. Each step shall be record the frequency error rate.
3. The temperature range step is 10 degrees in this test items. All temperature levels shall be hold the $\pm 0.5^{\circ}\text{C}$ during the measurement testing. The each temperature step shall be at least 0.5 hours, consider the EUT could be test under the stability condition.
4. The frequency error was recorded frequency error from the communication simulator.

3.7.3 TEST SETUP LAYOUT

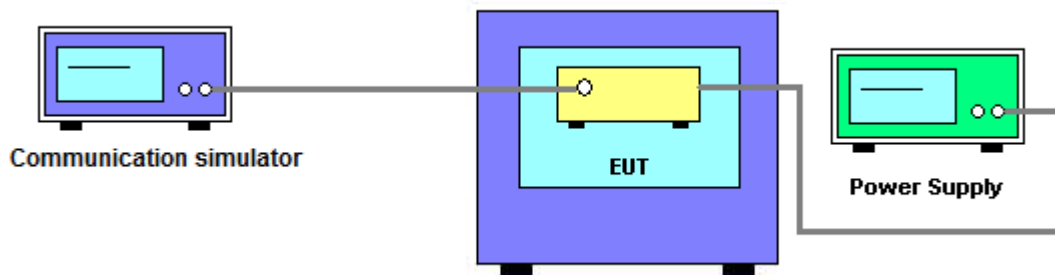

3.7.4 TEST DEVIATION

No deviation

3.7.5 TEST RESULTS

Please refer to the APPENDIX I.

4. LIST OF MEASUREMENT EQUIPMENTS

Radiated Spurious Emission Measurement					
Item	Kind of Equipment	Manufacturer	Type No.	Serial No.	Calibrated until
1	Antenna	Schwarzbeck	VULB9160	9160-3232	Mar. 15, 2022
2	Amplifier	Agilent	8449B	3008A02334	Feb. 27, 2022
3	High Pass Filter	Wairwright Instruments Gmbh	WHK 1.5/15G-10ST	11	Feb. 27, 2022
4	Band Reject Filter	Wairwright Instruments Gmbh	WRCG 1710/1785-1690/1805-60/ 12SS	38	Feb. 27, 2022
5	Band Reject Filter	Wairwright Instruments Gmbh	WRCG 824/849-810/863-60/9SS	7	Feb. 27, 2022
6	Band Reject Filter	Wairwright Instruments Gmbh	WRCG 880/915-860/935-60/9SS	14	Feb. 27, 2022
7	Band Reject Filter	Wairwright Instruments Gmbh	WRCG 1850/1910-1830/1930-60/ 10SS	17	Feb. 27, 2022
8	High Pass Filter	Wairwright Instruments Gmbh	WHK3.1/18G-10SS	24	Feb. 27, 2022
9	Wireless Communication Test SET	Agilent	E5515C	MY48364183	Feb. 28, 2022
10	Microwave Preamplifier With Adaptor	EMC INSTRUMENT	EMC2654045	980039 & HA01	Feb. 28, 2022
11	Receiver	Agilent	N9038A	MY52130039	Mar. 19, 2022
12	wideband radio communication tester	R&S	CMW500	152372	Feb. 27, 2022
13	High pass filter	KANGMAIWEI	ZHPF-M3-12.75G-3869	B2015073763	Feb. 07, 2022
14	High pass filter	KANGMAIWEI	ZHPF-M1000-4000-1	B2015073762	Feb. 07, 2022
15	High pass filter	KANGMAIWEI	ZHPF-M6-186-1727	B2015073764	Feb. 07, 2022
16	Cable	emci	LMR-400(30MHz-1GHz) (8m+5m)	N/A	May 20, 2022
17	Cable	mitron	RWLP50-4.0A-KJ-SMSM- 12M	N/A	Nov. 23, 2021
18	Controller	ETS-Lindgren	2090	N/A	N/A
19	Measurement Software	Farad	EZ-EMC Ver.NB-03A1-01	N/A	N/A
20	Loop Antenna	EM	EM-6876-1	230	Apr. 28, 2022
21	Double Ridged Guide Antenna	ETS	3115	75846	Mar. 17, 2022
22	Broad-Band Horn Antenna	Schwarzbeck	BBHA 9170	9170319	Jun. 30, 2022

Conducted Measurement					
Item	Kind of Equipment	Manufacturer	Type No.	Serial No.	Calibrated until
1	Wireless Communication Test SET	Agilent	E5515C	MY48364183	Feb. 28, 2022
2	EXA Spectrum Analyzer	Agilent	N9010A	MY50520044	Feb. 28, 2022
3	POWER SPLITTER	Mini-Circuits	ZFRSC-123-S+	331000910-1	Feb. 27, 2022
4	wideband radio communication tester	R&S	CMW500	152372	Feb. 27, 2022

Frequency Stability Measurement					
Item	Kind of Equipment	Manufacturer	Type No.	Serial No.	Calibrated until
1	Wireless Communication Test SET	Agilent	E5515C	MY48364183	Feb. 28, 2022
2*	Multi-output DC Power Supply	GW Instek	GPC-3030DN	EK880675	Jul. 25, 2023
3	POWER SPLITTER	Mini-Circuits	ZFRSC-123-S+	331000910-1	Feb. 27, 2022
4	wideband radio communication tester	R&S	CMW500	152372	Feb. 27, 2022
5	Const Temp, & Humidity Chamber	Bell	BTH-50C	20170306001	Feb. 27, 2022

Remark: "N/A" denotes no model name, serial no. or calibration specified.

"*" calibration period of equipment list is three year.

Except * item, all calibration period of equipment list is one year.

APPENDIX A - OUTPUT POWER

Output Power (dBm):

LTE Band	Sub-carrier Spacing (kHz)	Modulation	N _{tones}	Tone offset	Low CH	Mid CH	High CH
					CH18601	CH18900	CH19199
					1850.1MHz	1880MHz	1909.9MHz
2	3.75	BPSK	1	0	19.46	19.74	19.86
			1	47	19.32	19.64	19.76
		QPSK	1	0	19.43	19.76	19.94
			1	47	19.38	19.66	19.71
	15	BPSK	1	0	19.87	20.50	20.48
			1	11	19.83	20.41	20.47
		QPSK	1	0	19.98	20.68	20.64
			1	11	19.91	20.59	20.58

LTE Band	Sub-carrier Spacing (kHz)	Modulation	N _{tones}	Tone offset	Low CH	Mid CH	High CH
					CH26041	CH26365	CH26689
					1850.1MHz	1882.5MHz	1914.9MHz
25	3.75	BPSK	1	0	20.36	20.54	19.44
			1	47	20.29	20.49	19.37
		QPSK	1	0	20.28	20.52	19.48
			1	47	20.22	20.54	19.35
	15	BPSK	1	0	19.93	20.62	20.24
			1	11	19.84	20.56	20.33
		QPSK	1	0	20.00	20.80	20.44
			1	11	19.92	20.73	20.44

EIRP (dBm):

LTE Band	Sub-carrier Spacing (kHz)	Modulation	N _{tones}	Tone offset	Low CH	Mid CH	High CH
					CH18601	CH18900	CH19199
					1850.1MHz	1880MHz	1909.9MHz
2	3.75	BPSK	1	0	22.56	22.84	22.96
			1	47	22.42	22.74	22.86
		QPSK	1	0	22.53	22.86	23.04
			1	47	22.48	22.76	22.81
	15	BPSK	1	0	22.97	23.60	23.58
			1	11	22.93	23.51	23.57
		QPSK	1	0	23.08	23.78	23.74
			1	11	23.01	23.69	23.68

LTE Band	Sub-carrier Spacing (kHz)	Modulation	N _{tones}	Tone offset	Low CH	Mid CH	High CH
					CH26041	CH26365	CH26689
					1850.1MHz	1882.5MHz	1914.9MHz
25	3.75	BPSK	1	0	23.46	23.64	22.54
			1	47	23.39	23.59	22.47
		QPSK	1	0	23.38	23.62	22.58
			1	47	23.32	23.64	22.45
	15	BPSK	1	0	23.03	23.72	23.34
			1	11	22.94	23.66	23.43
		QPSK	1	0	23.10	23.90	23.54
			1	11	23.02	23.83	23.54

APPENDIX B - OCCUPIED BANDWIDTH

LTE Band 2_3.75KHz					
BPSK			1RB#0		
Channel	Frequency (MHz)	99% Occupied Bandwidth (KHz)	Channel	Frequency (MHz)	26dB Bandwidth (KHz)
18601	1850.1	61.068	18601	1850.1	41.40
18900	1880	61.205	18900	1880	41.75
19199	1909.9	61.440	19199	1909.9	41.36
QPSK			1RB#0		
Channel	Frequency (MHz)	99% Occupied Bandwidth (KHz)	Channel	Frequency (MHz)	26dB Bandwidth (KHz)
18601	1850.1	65.495	18601	1850.1	42.55
18900	1880	66.308	18900	1880	40.52
19199	1909.9	62.092	19199	1909.9	38.97

Spectrum Plot

1RB#0

BPSK-18601

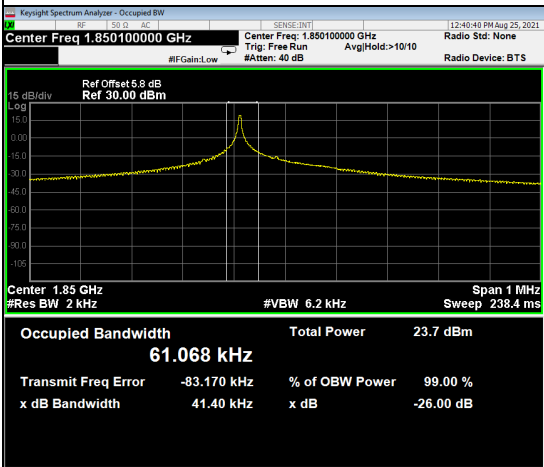

BPSK-18900



BPSK-19199

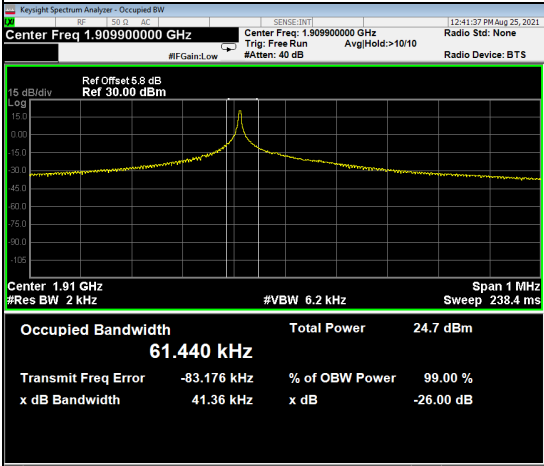

QPSK-18601

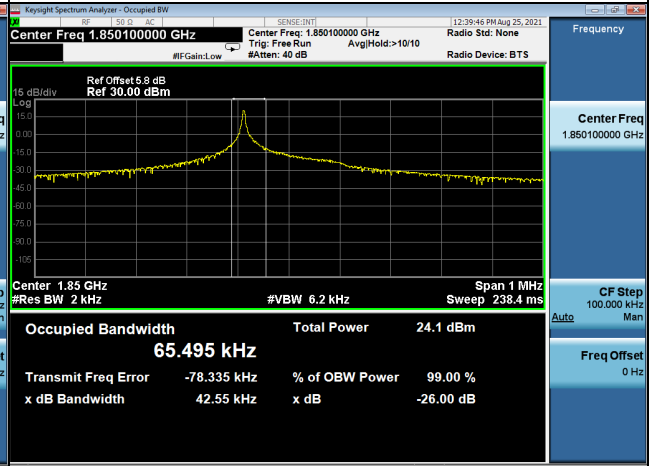

QPSK-18900

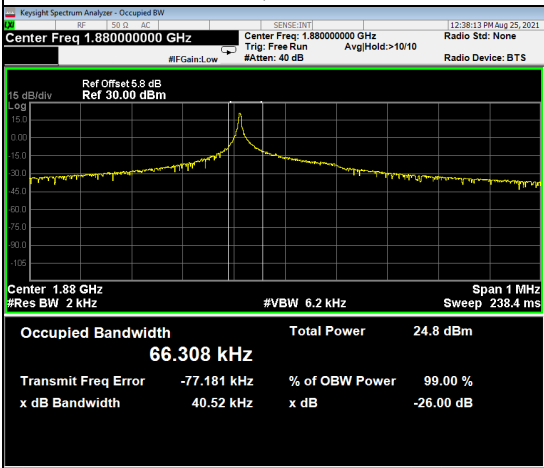

QPSK-19199

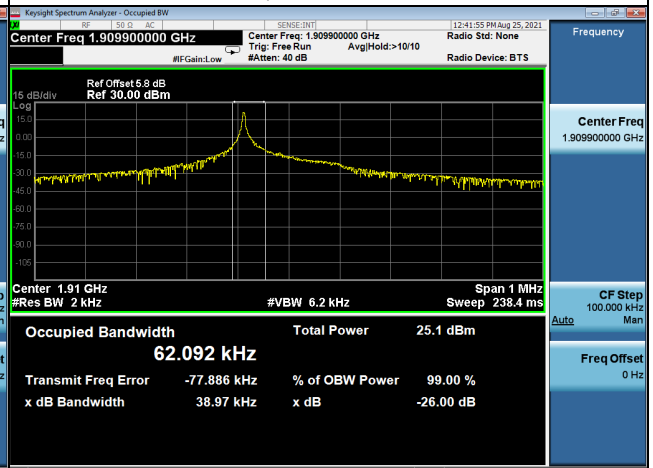

LTE Band 2_15KHz					
BPSK			1RB#0		
Channel	Frequency (MHz)	99% Occupied Bandwidth (KHz)	Channel	Frequency (MHz)	26dB Bandwidth (KHz)
18601	1850.1	120.91	18601	1850.1	104.6
18900	1880	120.91	18900	1880	112.4
19199	1909.9	122.54	19199	1909.9	106.6
QPSK			1RB#0		
Channel	Frequency (MHz)	99% Occupied Bandwidth (KHz)	Channel	Frequency (MHz)	26dB Bandwidth (KHz)
18601	1850.1	119.57	18601	1850.1	118.4
18900	1880	130.62	18900	1880	130.8
19199	1909.9	126.32	19199	1909.9	116.9
QPSK			12RB#0		
Channel	Frequency (MHz)	99% Occupied Bandwidth (KHz)	Channel	Frequency (MHz)	26dB Bandwidth (KHz)
18601	1850.1	185.51	18601	1850.1	247.8
18900	1880	185.72	18900	1880	250.0
19199	1909.9	187.46	19199	1909.9	251.4

Spectrum Plot

1RB#0

BPSK-18601

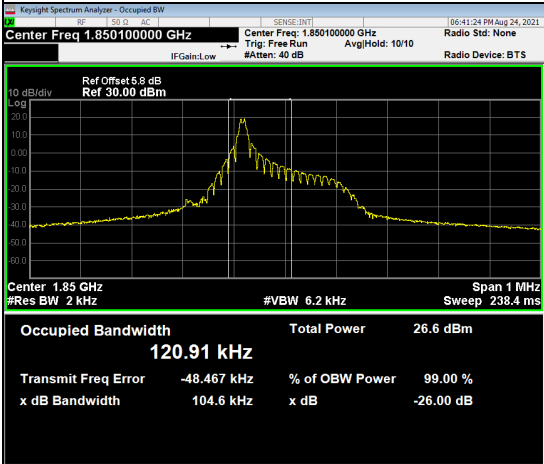

BPSK-18900

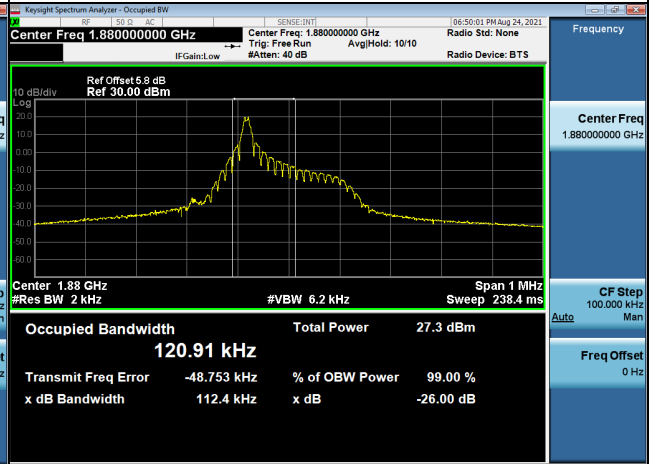

BPSK-19199

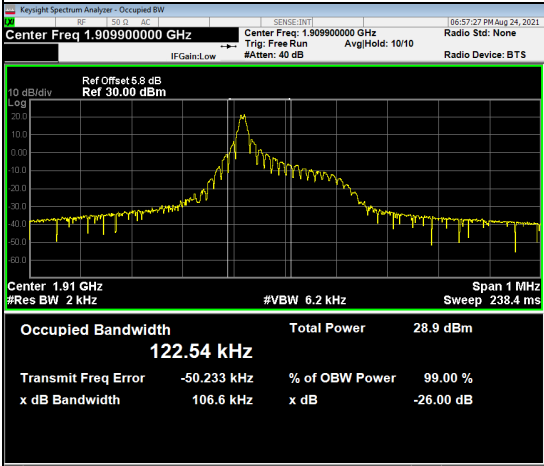

QPSK-18601

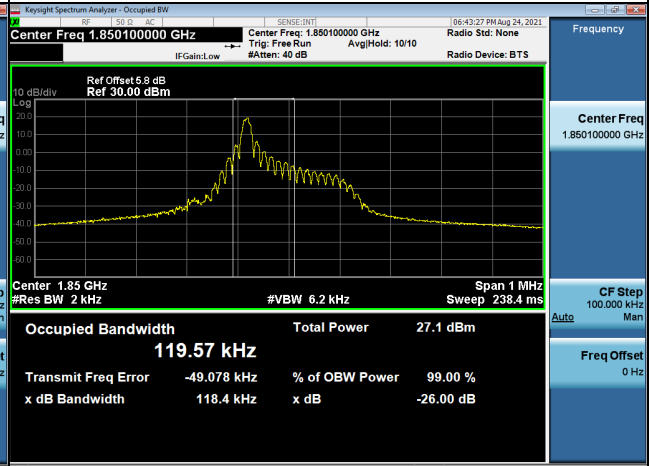

QPSK-18900

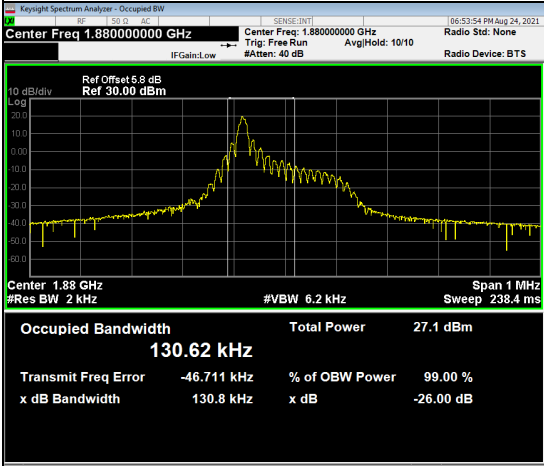

QPSK-19199

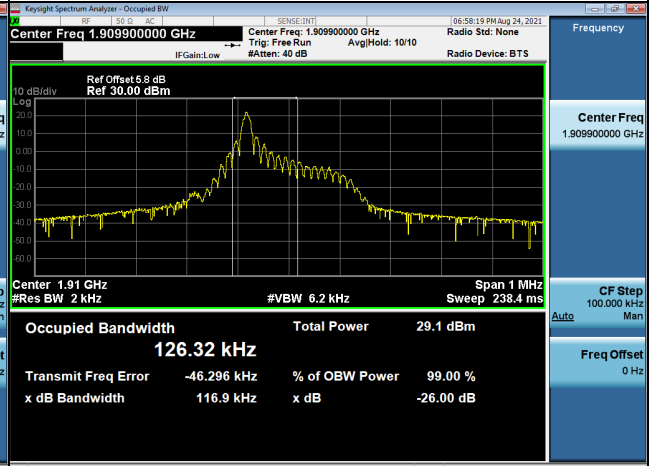

Spectrum Plot

12RB#0

QPSK-18601

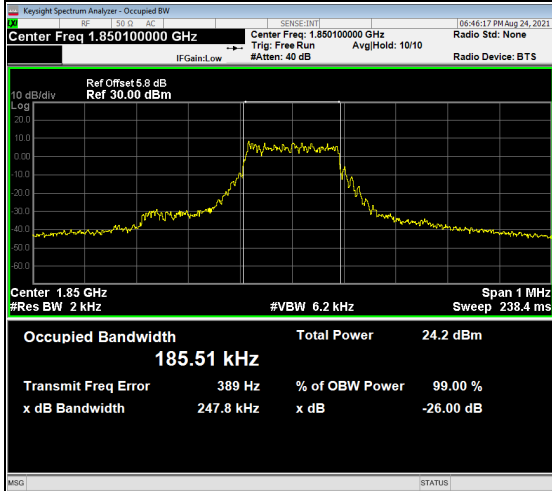

QPSK-18900

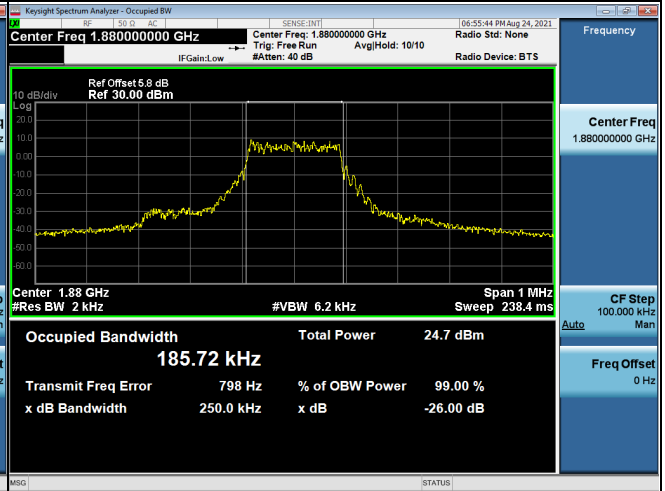

QPSK-19199

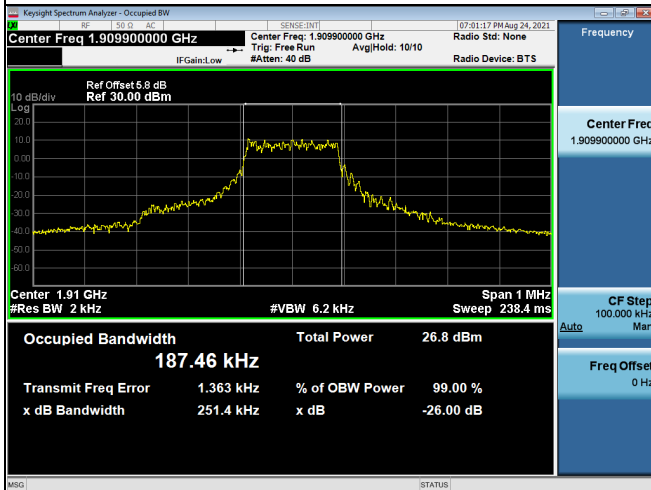

LTE Band 25_3.75KHz					
BPSK			1RB#0		
Channel	Frequency (MHz)	99% Occupied Bandwidth (KHz)	Channel	Frequency (MHz)	26dB Bandwidth (KHz)
26041	1850.1	60.028	26041	1850.1	40.64
26365	1882.5	61.238	26365	1882.5	41.33
26689	1914.9	60.646	26689	1914.9	41.46
QPSK			1RB#0		
Channel	Frequency (MHz)	99% Occupied Bandwidth (KHz)	Channel	Frequency (MHz)	26dB Bandwidth (KHz)
26041	1850.1	66.085	26041	1850.1	39.92
26365	1882.5	64.989	26365	1882.5	42.37
26689	1914.9	66.660	26689	1914.9	40.59

Spectrum Plot

1RB#0

BPSK-26041

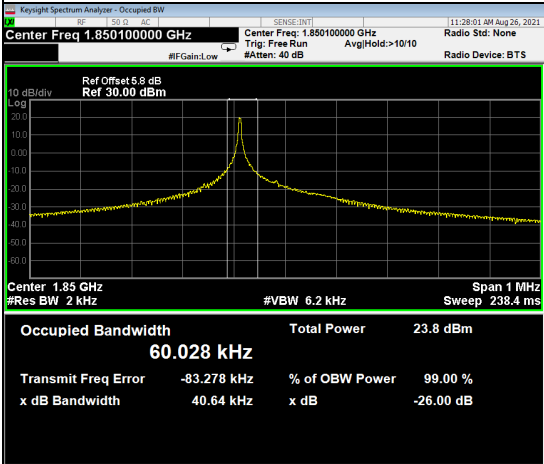

BPSK-26365

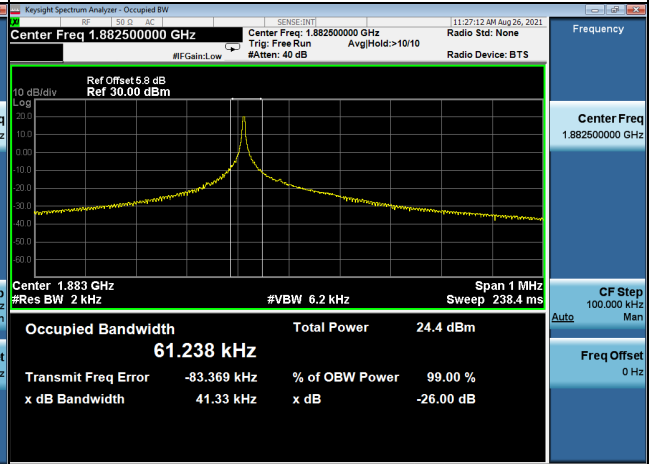

BPSK-26689

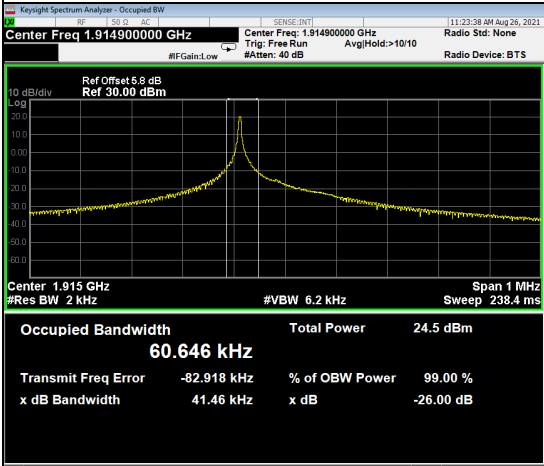

QPSK-26041

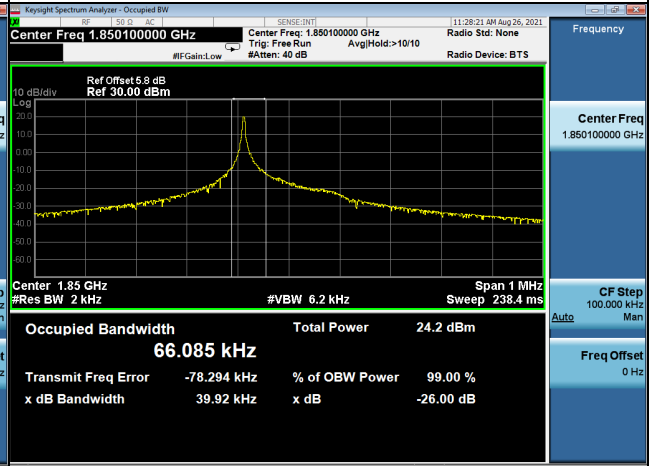

QPSK-26365

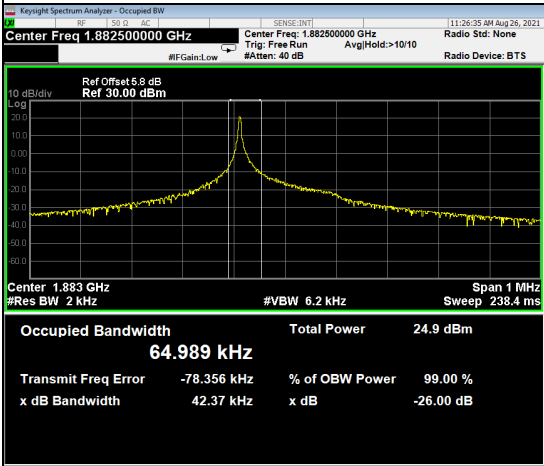

QPSK-26689

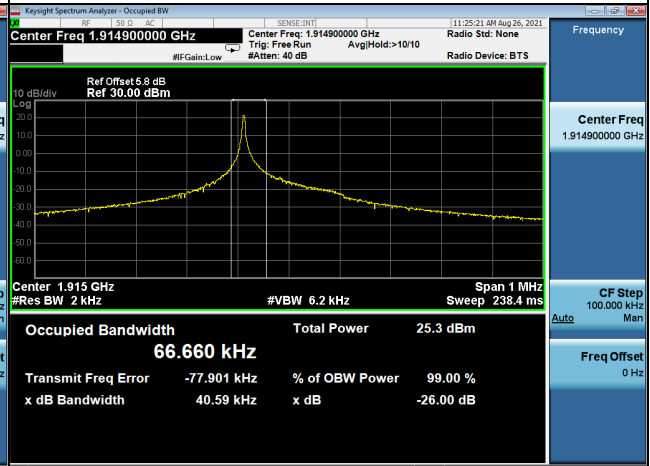

LTE Band 25_15KHz					
BPSK			1RB#0		
Channel	Frequency (MHz)	99% Occupied Bandwidth (KHz)	Channel	Frequency (MHz)	26dB Bandwidth (KHz)
26041	1850.1	121.07	26041	1850.1	105.4
26365	1882.5	119.58	26365	1882.5	106.5
26689	1914.9	121.30	26689	1914.9	106.4
QPSK			1RB#0		
Channel	Frequency (MHz)	99% Occupied Bandwidth (KHz)	Channel	Frequency (MHz)	26dB Bandwidth (KHz)
26041	1850.1	120.33	26041	1850.1	129.7
26365	1882.5	117.15	26365	1882.5	104.2
26689	1914.9	122.83	26689	1914.9	117.8
QPSK			12RB#0		
Channel	Frequency (MHz)	99% Occupied Bandwidth (KHz)	Channel	Frequency (MHz)	26dB Bandwidth (KHz)
26041	1850.1	185.02	26041	1850.1	249.3
26365	1882.5	185.59	26365	1882.5	248.5
26689	1914.9	183.82	26689	1914.9	248.1

Spectrum Plot

1RB#0

BPSK-26041

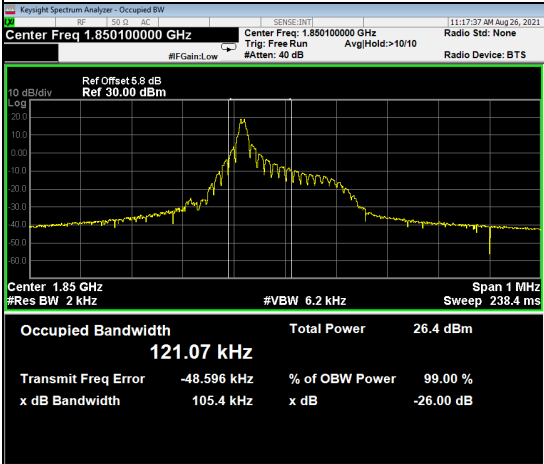

BPSK-26365

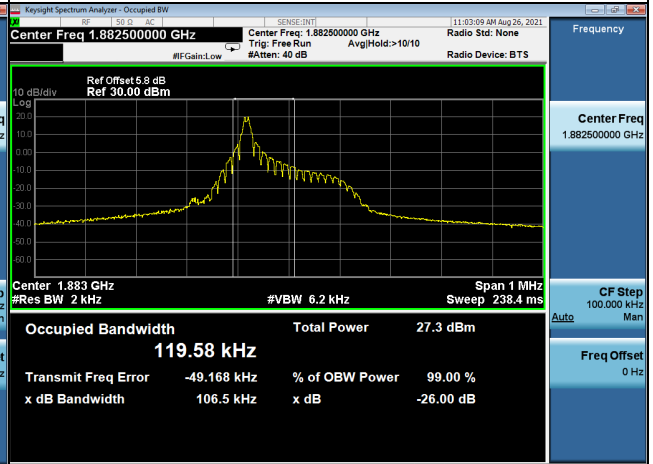

BPSK-26689

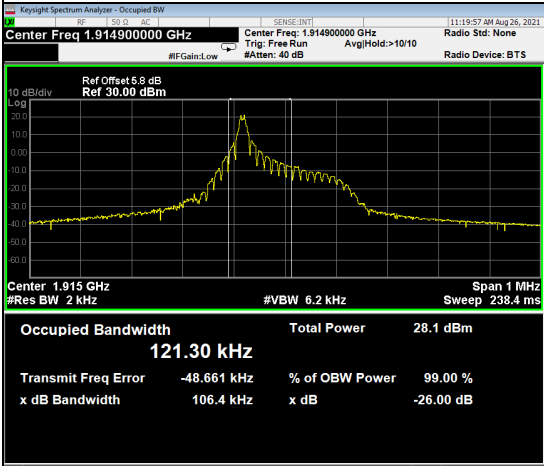

QPSK-26041

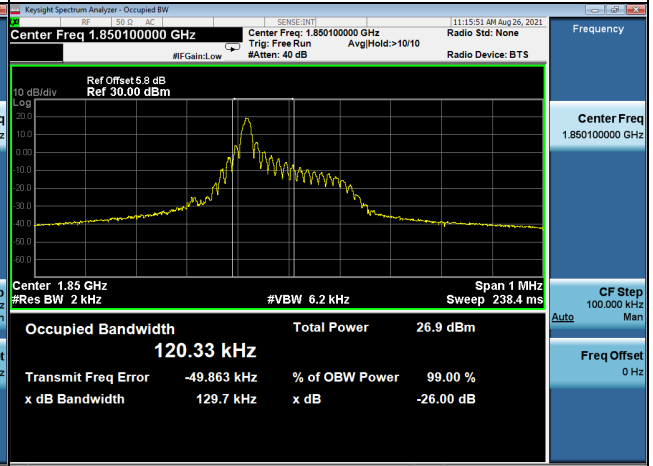

QPSK-26365

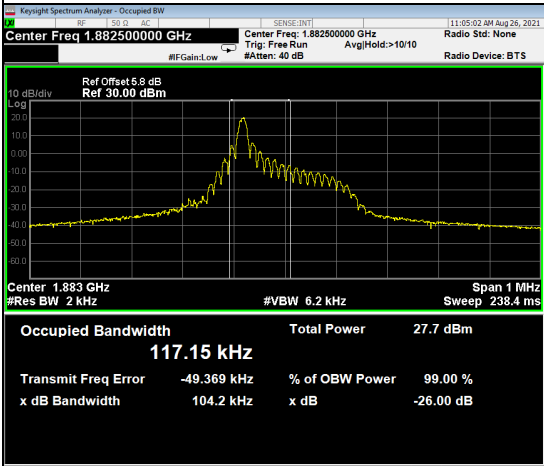

QPSK-26689

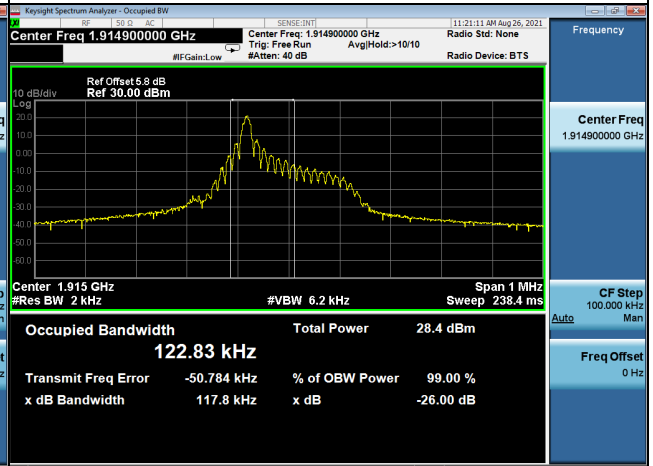

Spectrum Plot

12RB#0

QPSK-26041

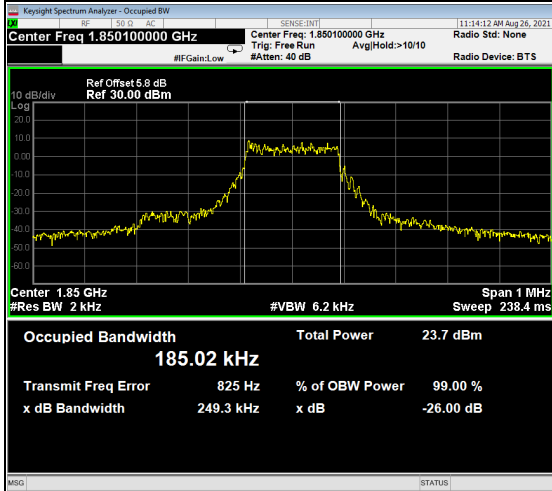

QPSK-26365

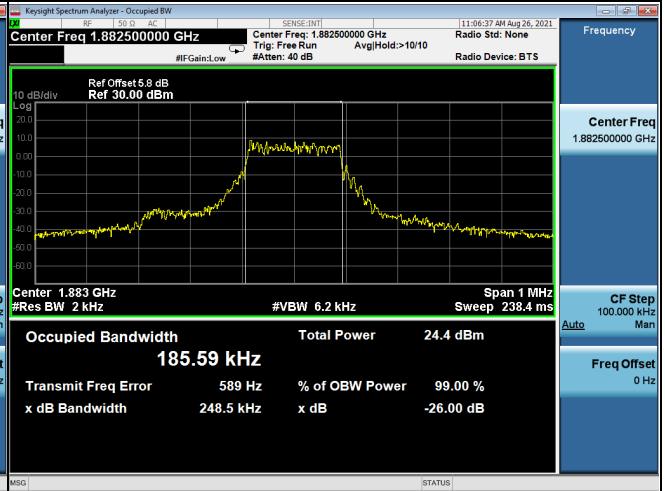

QPSK-26689

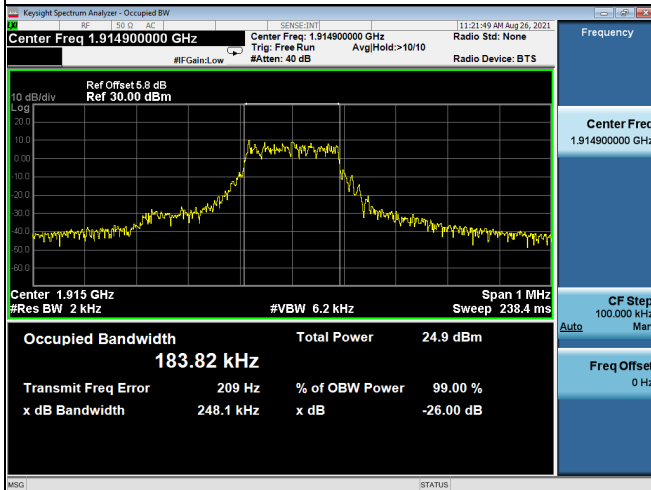

APPENDIX C - CONDUCTED SPURIOUS EMISSIONS

LTE Band 2_BPSK_3.75KHz Spectrum Plot

Channel	Frequency(MHz)	Channel	Frequency(MHz)
18900	1880	18900	1880
Channel	Frequency(MHz)	-	-
18900	1880	-	-

LTE Band 2_BPSK_15KHz Spectrum Plot

Channel	Frequency(MHz)	Channel	Frequency(MHz)
18900	1880	18900	1880
<p>Date: 26.AUG.2021 15:25:41</p>		<p>Date: 26.AUG.2021 14:28:43</p>	
Channel	Frequency(MHz)	-	-
18900	1880	-	-
<p>Date: 26.AUG.2021 15:27:00</p>			

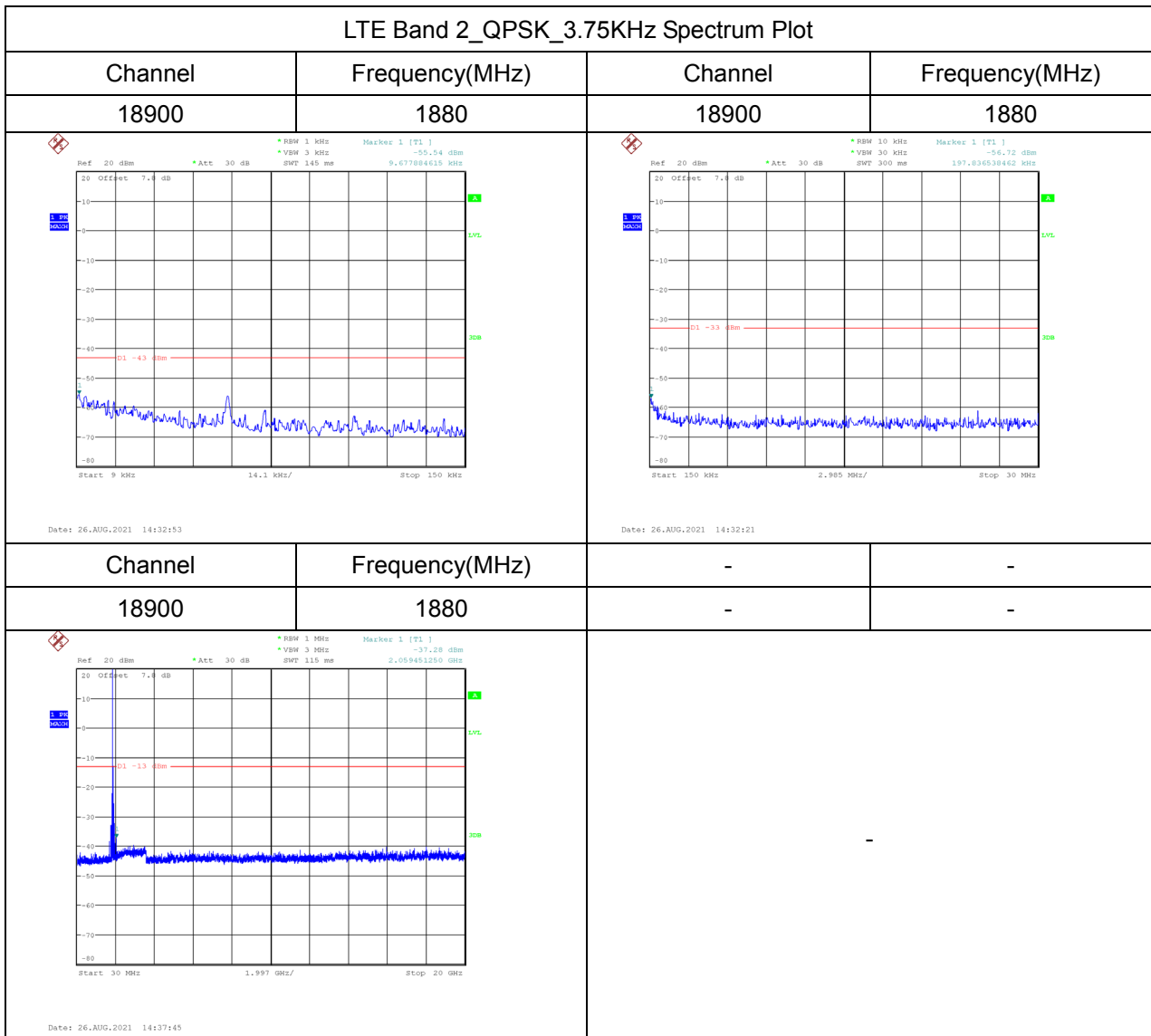

LTE Band 2_QPSK_15KHz Spectrum Plot			
Channel	Frequency(MHz)	Channel	Frequency(MHz)
18900	1880	18900	1880
<p>Ref 20 dBm Att 30 dB RBW 1 kHz VBW 3 kHz SWT 145 ms MacRece 1 (T1) -54.80 dBm 10.308769231 kHz</p> <p>Start 9 kHz 14.1 kHz/ Stop 150 kHz</p> <p>Date: 26.AUG.2021 15:25:55</p>	<p>Ref 20 dBm Att 30 dB RBW 30 kHz VBW 30 kHz SWT 300 ms MacRece 1 (T1) -55.35 dBm 107.036538462 kHz</p> <p>Start 150 kHz 2.985 MHz/ Stop 30 kHz</p> <p>Date: 26.AUG.2021 14:29:24</p>		
Channel	Frequency(MHz)	-	-
18900	1880	-	-
<p>Ref 20 dBm Att 30 dB RBW 1 MHz VBW 3 MHz SWT 115 ms MacRece 1 (T1) -30.07 dBm 1.659601250 GHz</p> <p>Start 30 MHz 1.997 GHz/ Stop 20 GHz</p> <p>Date: 26.AUG.2021 15:26:41</p>			

LTE Band 25_BPSK_3.75KHz Spectrum Plot			
Channel	Frequency(MHz)	Channel	Frequency(MHz)
26365	1882.5	26365	1882.5
<p>Ref 20 dBm Offset 7.4 dB Att 30 dB RBW 1 KHz VBM 3 KHz SWF 145 ms MacRec 1 (T1) -55.49 dBm 63.486730769 MHz</p> <p>Date: 26.AUG.2021 14:44:01</p>		<p>Ref 20 dBm Offset 7.4 dB Att 30 dB RBW 30 KHz VBM 30 KHz SWF 300 ms MacRec 1 (T1) -55.63 dBm 107.036538462 MHz</p> <p>Date: 26.AUG.2021 14:43:13</p>	
Channel	Frequency(MHz)	-	-
26365	1882.5	-	-
<p>Ref 20 dBm Offset 7.4 dB Att 30 dB RBW 1 MHz VBM 3 MHz SWF 115 ms MacRec 1 (T1) -37.43 dBm 2.061647500 GHz</p> <p>Date: 26.AUG.2021 14:45:00</p>			

LTE Band 25_BPSK_15KHz Spectrum Plot

Channel	Frequency(MHz)	Channel	Frequency(MHz)
26365	1882.5	26365	1882.5
Date: 26.AUG.2021 15:30:08		Date: 26.AUG.2021 15:29:47	
Channel	Frequency(MHz)	-	-
26365	1882.5	-	-
		-	
Date: 26.AUG.2021 15:31:39			

LTE Band 25_QPSK_3.75kHz Spectrum Plot

Channel	Frequency(MHz)	Channel	Frequency(MHz)
26365	1882.5	26365	1882.5
Date: 26.AUG.2021 14:43:44		Date: 26.AUG.2021 14:43:28	
Channel	Frequency(MHz)	-	-
26365	1882.5	-	-
		-	
Date: 26.AUG.2021 14:46:03			

LTE Band 25_QPSK_15KHz Spectrum Plot

Channel	Frequency(MHz)	Channel	Frequency(MHz)
26365	1882.5	26365	1882.5
Channel	Frequency(MHz)	-	-
26365	1882.5	-	-
		-	

APPENDIX D - RADIATED SPURIOUS EMISSIONS (9KHZ TO 30MHZ)

Test Mode	TX Mode
-----------	---------

Ant 0°

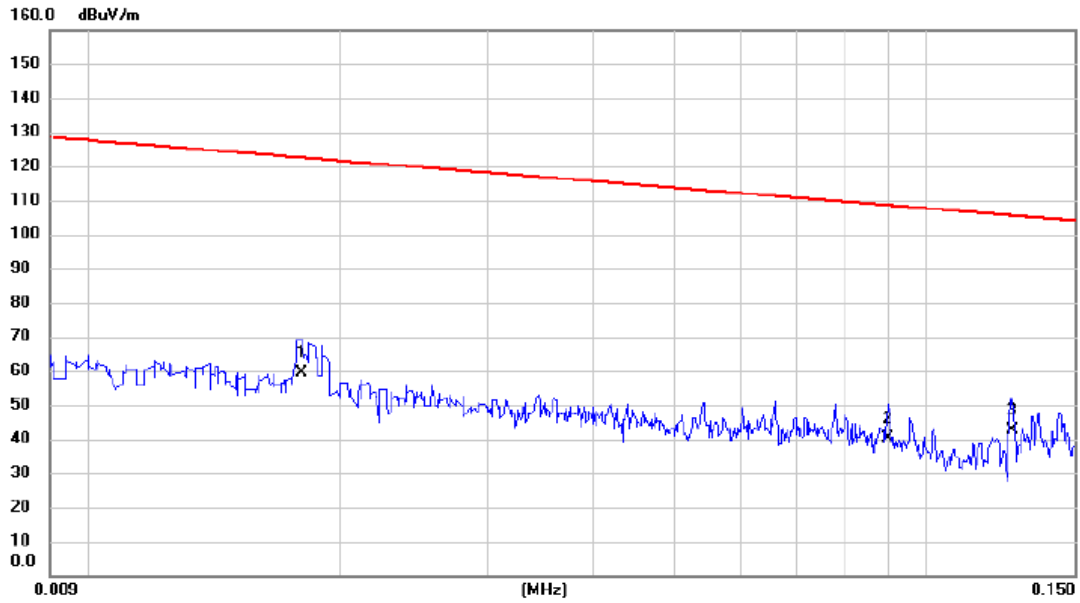

No.	Mk.	Freq.	Reading Level	Correct Factor	Measurement	Limit	Margin	Antenna Height	Table Degree	
		MHz	dBuV	dB	dBuV/m	dBuV/m	dB	cm	degree	Comment
1	*	0.0180	45.65	13.84	59.49	122.50	-63.01	AVG		
2		0.0900	27.48	12.66	40.14	108.52	-68.38	AVG		
3		0.1263	29.68	12.73	42.41	105.58	-63.17	AVG		

Test Mode TX Mode

Ant 0°

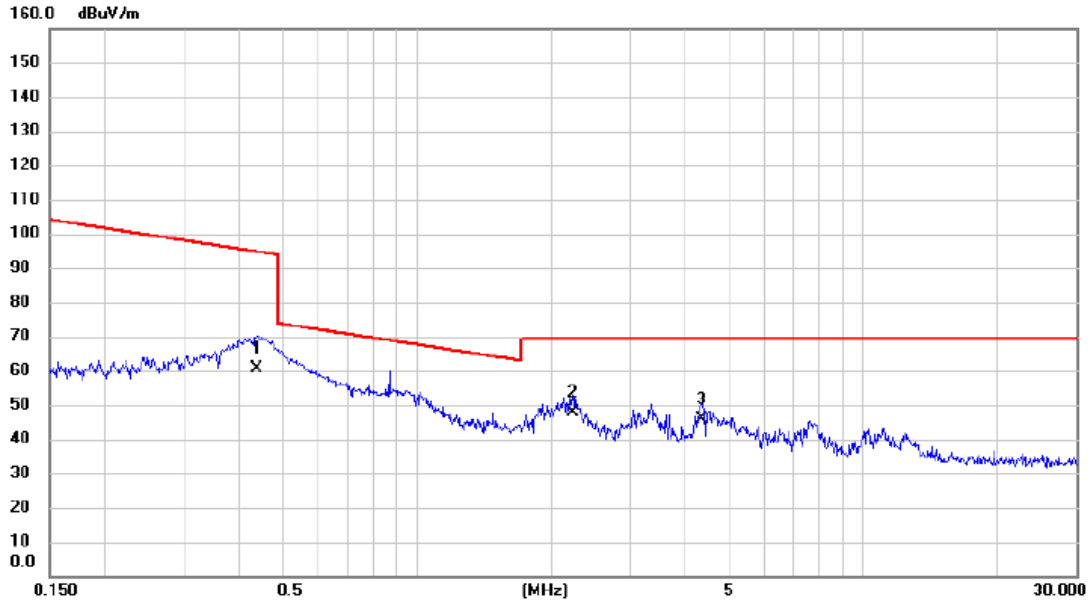

No.	Mk.	Freq.	Reading Level	Correct Factor	Measurement	Limit	Margin	Antenna Height	Table Degree	
		MHz	dBuV	dB	dBuV/m	dBuV/m	dB	cm	degree	Comment
1		0.4374	48.25	12.17	60.42	94.79	-34.37			AVG
2	*	2.2367	36.79	11.19	47.98	69.54	-21.56			QP
3		4.3606	34.85	11.00	45.85	69.54	-23.69			QP

Test Mode TX Mode

Ant 90°

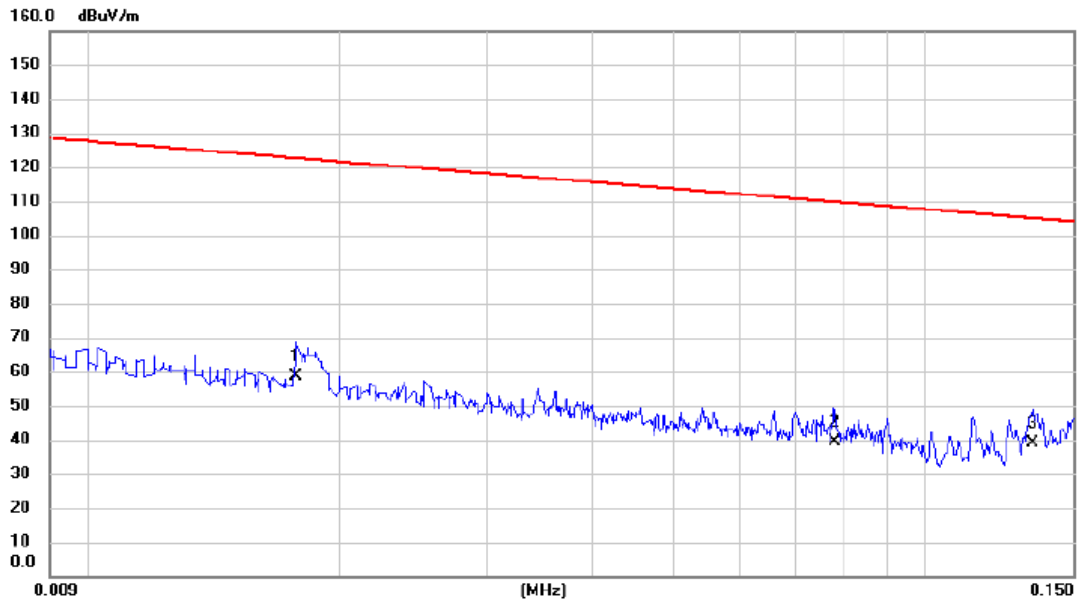

No.	Mk.	Freq.	Reading Level	Correct Factor	Measurement	Limit	Margin	Antenna Height	Table Degree	
		MHz	dBuV	dB	dBuV/m	dBuV/m	dB	cm	degree	Comment
1	*	0.0177	44.51	13.93	58.44	122.65	-64.21	AVG		
2		0.0780	26.89	12.59	39.48	109.76	-70.28	AVG		
3		0.1344	26.43	12.73	39.16	105.04	-65.88	AVG		

Test Mode	TX Mode
-----------	---------

Ant 90°

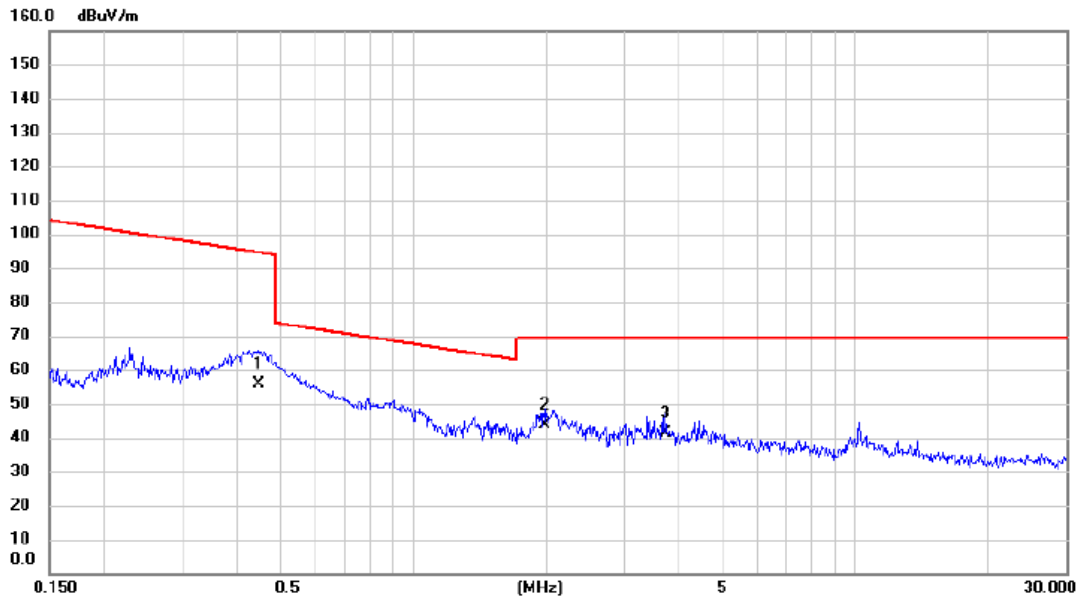

No.	Mk.	Freq.	Reading Level	Correct Factor	Measurement	Limit	Margin	Antenna Height	Table Degree	
		MHz	dBuV	dB	dBuV/m	dBuV/m	dB	cm	degree	Comment
1		0.4468	43.83	12.14	55.97	94.60	-38.63			AVG
2	*	1.9906	32.57	11.31	43.88	69.54	-25.66			QP
3		3.7198	30.49	10.91	41.40	69.54	-28.14			QP

APPENDIX E - RADIATED SPURIOUS EMISSIONS (30MHZ TO 1000MHZ)

Test Mode LTE Band 2_BPSK_TX CH18900_3.75KHz

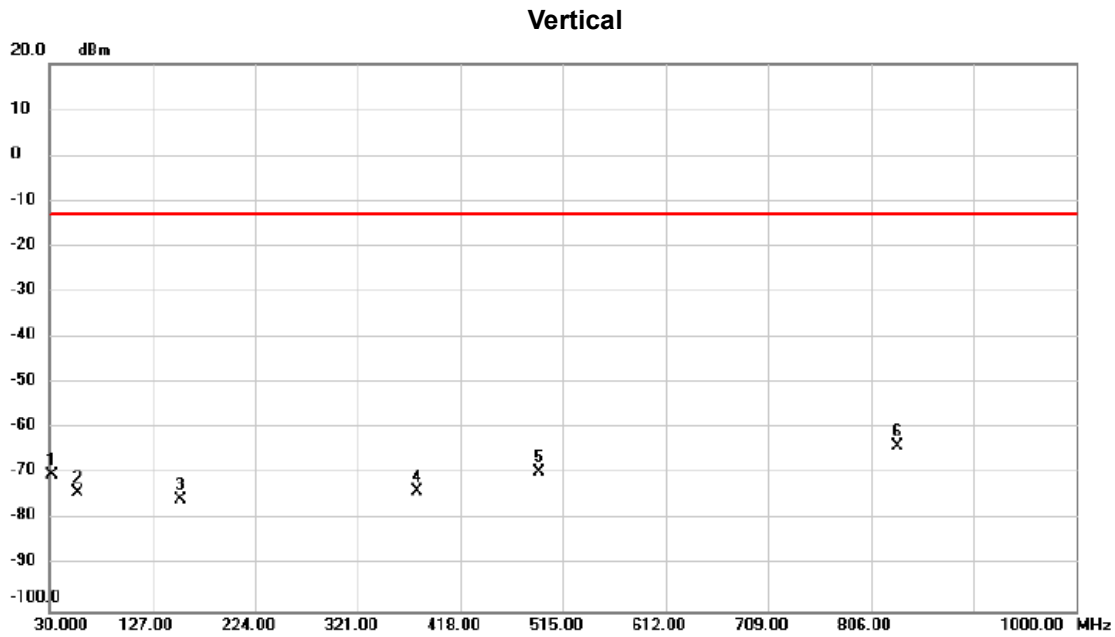

No.	Mk.	Freq. MHz	Reading Level dBm	Correct Factor dB	Measure- ment dBm	Limit dBm	Margin dB	Detector	Comment
1		31.941	-64.33	-5.76	-70.09	-13.00	-57.09	peak	
2		56.199	-69.59	-4.58	-74.17	-13.00	-61.17	peak	
3		153.878	-72.42	-3.00	-75.42	-13.00	-62.42	peak	
4		377.376	-73.85	0.12	-73.73	-13.00	-60.73	peak	
5		492.197	-72.35	2.68	-69.67	-13.00	-56.67	peak	
6	*	830.840	-72.77	8.80	-63.97	-13.00	-50.97	peak	

Test Mode: LTE Band 2_BPSK_TX CH18900_1.4M_3.75KHz

Horizontal

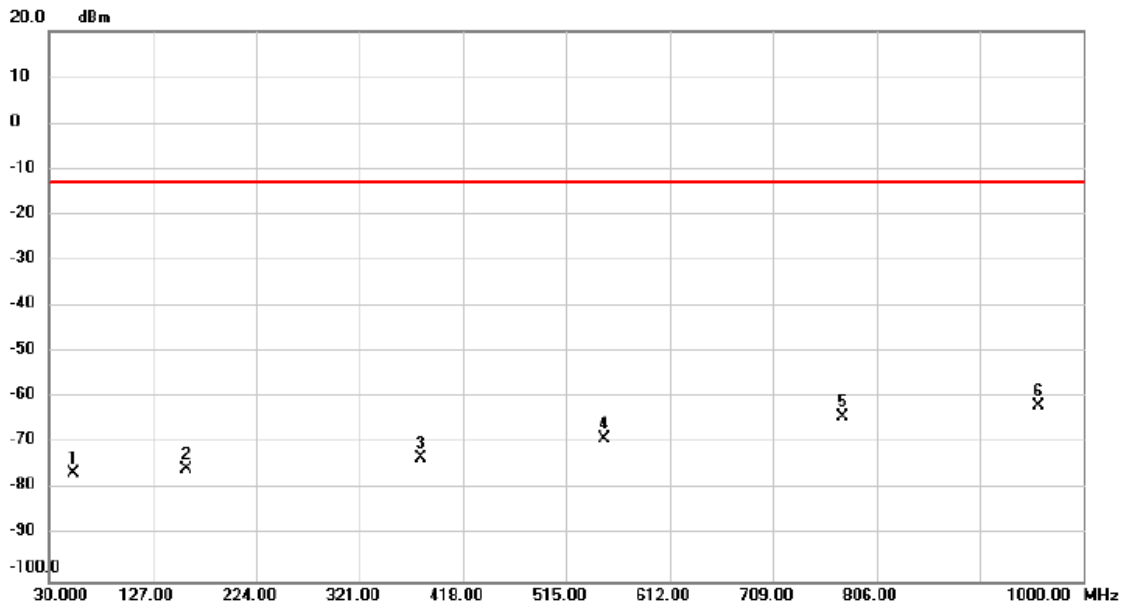

No.	Mk.	Freq. MHz	Reading Level dBm	Correct Factor dB	Measure- ment dBm	Limit dBm	Margin dB	Detector	Comment
1		51.994	-72.31	-4.20	-76.51	-13.00	-63.51	peak	
2		158.730	-72.77	-2.88	-75.65	-13.00	-62.65	peak	
3		378.023	-73.25	0.13	-73.12	-13.00	-60.12	peak	
4		550.417	-72.29	3.44	-68.85	-13.00	-55.85	peak	
5		774.562	-72.20	8.10	-64.10	-13.00	-51.10	peak	
6	*	957.629	-73.00	11.30	-61.70	-13.00	-48.70	peak	

Test Mode LTE Band 2_BPSK_TX CH18900_15KHz

Vertical

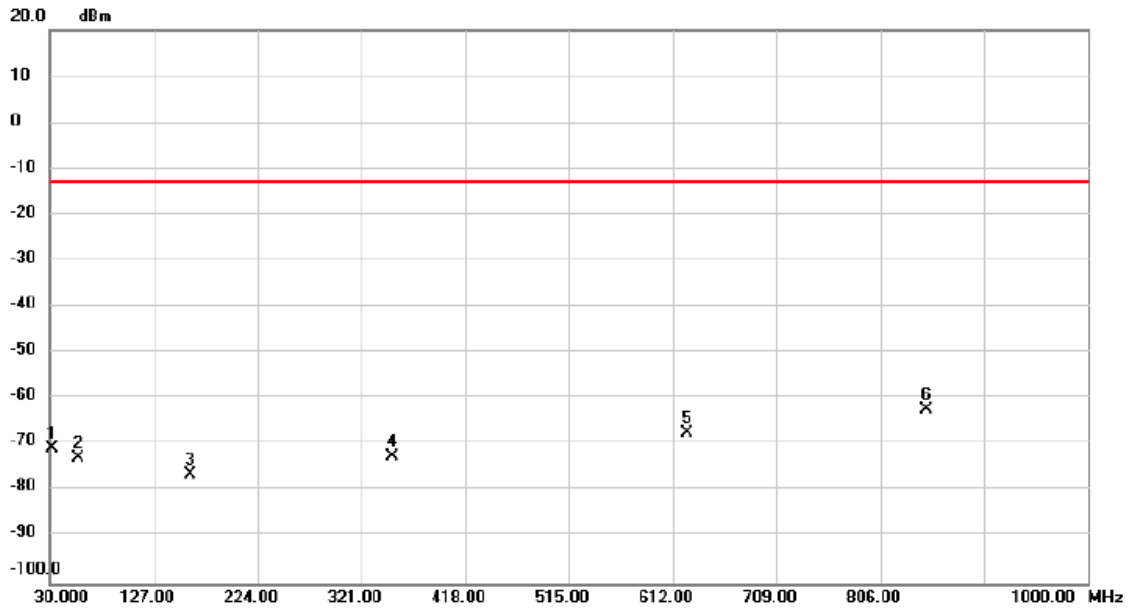

No. Mk.	Freq. MHz	Reading Level dBm	Correct Factor dB	Measurement dBm	Limit dBm	Margin dB	Detector	Comment
1	31.941	-65.01	-5.76	-70.77	-13.00	-57.77	peak	
2	56.522	-68.24	-4.59	-72.83	-13.00	-59.83	peak	
3	160.670	-73.58	-2.86	-76.44	-13.00	-63.44	peak	
4	349.883	-72.09	-0.52	-72.61	-13.00	-59.61	peak	
5	625.132	-72.63	5.17	-67.46	-13.00	-54.46	peak	
6 *	848.953	-71.16	8.82	-62.34	-13.00	-49.34	peak	

Test Mode LTE Band 2_BPSK_TX CH18900_15KHz

Horizontal

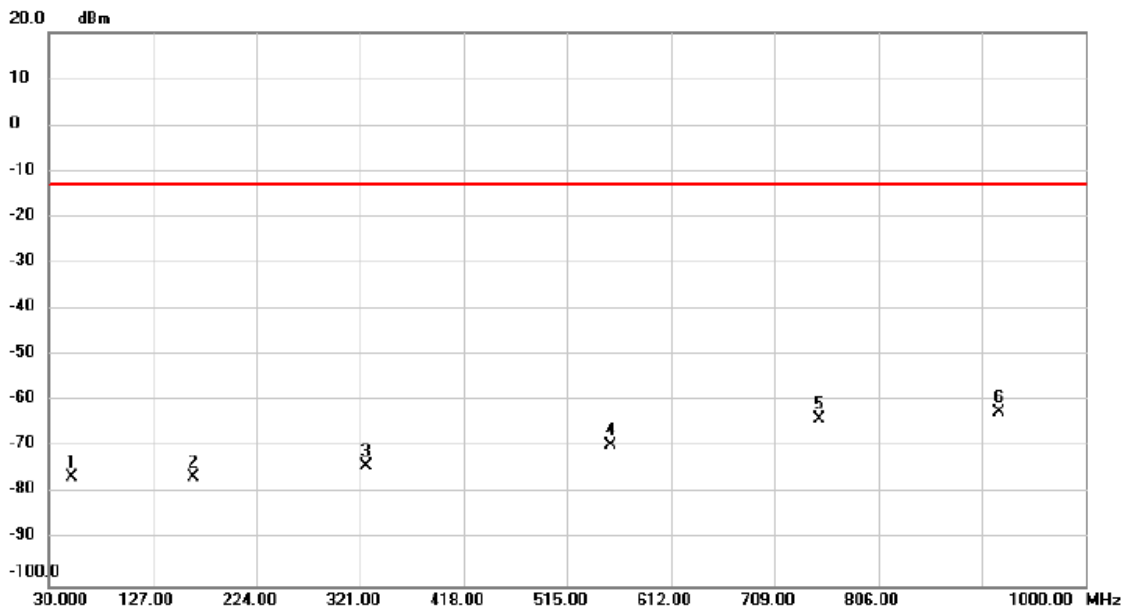

No. Mk.	Freq. MHz	Reading Level dBm	Correct Factor dB	Measure- ment dBm	Limit dBm	Margin dB	Detector	Comment
1	51.671	-72.36	-4.18	-76.54	-13.00	-63.54	peak	
2	164.875	-73.52	-2.95	-76.47	-13.00	-63.47	peak	
3	326.596	-73.03	-0.94	-73.97	-13.00	-60.97	peak	
4	555.915	-72.98	3.58	-69.40	-13.00	-56.40	peak	
5	750.627	-71.24	7.47	-63.77	-13.00	-50.77	peak	
6 *	919.787	-72.71	10.36	-62.35	-13.00	-49.35	peak	

Test Mode LTE Band 2_QPSK_TX CH18900_3.75KHz

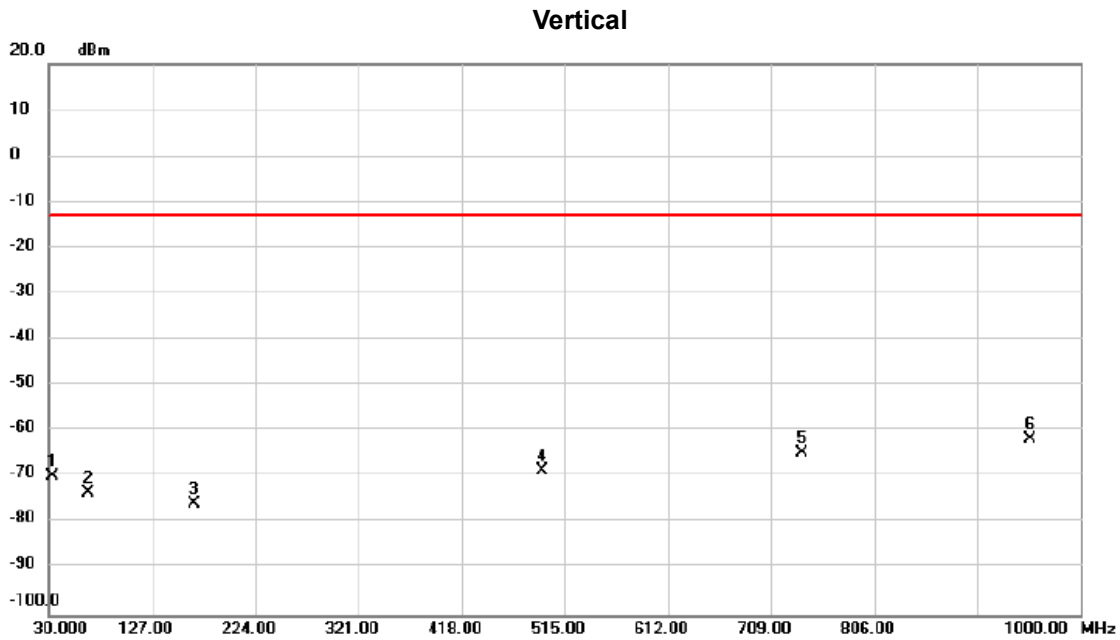

No.	Mk.	Freq. MHz	Reading Level dBm	Correct Factor dB	Measure- ment dBm	Limit dBm	Margin dB	Detector	Comment
1		32.587	-64.15	-5.66	-69.81	-13.00	-56.81	peak	
2		66.872	-67.47	-6.00	-73.47	-13.00	-60.47	peak	
3		166.169	-72.72	-2.99	-75.71	-13.00	-62.71	peak	
4		493.491	-71.42	2.69	-68.73	-13.00	-55.73	peak	
5		738.660	-72.04	7.19	-64.85	-13.00	-51.85	peak	
6	*	953.101	-73.18	11.29	-61.89	-13.00	-48.89	peak	

Test Mode LTE Band 2_QPSK_TX CH18900_3.75KHz

Horizontal

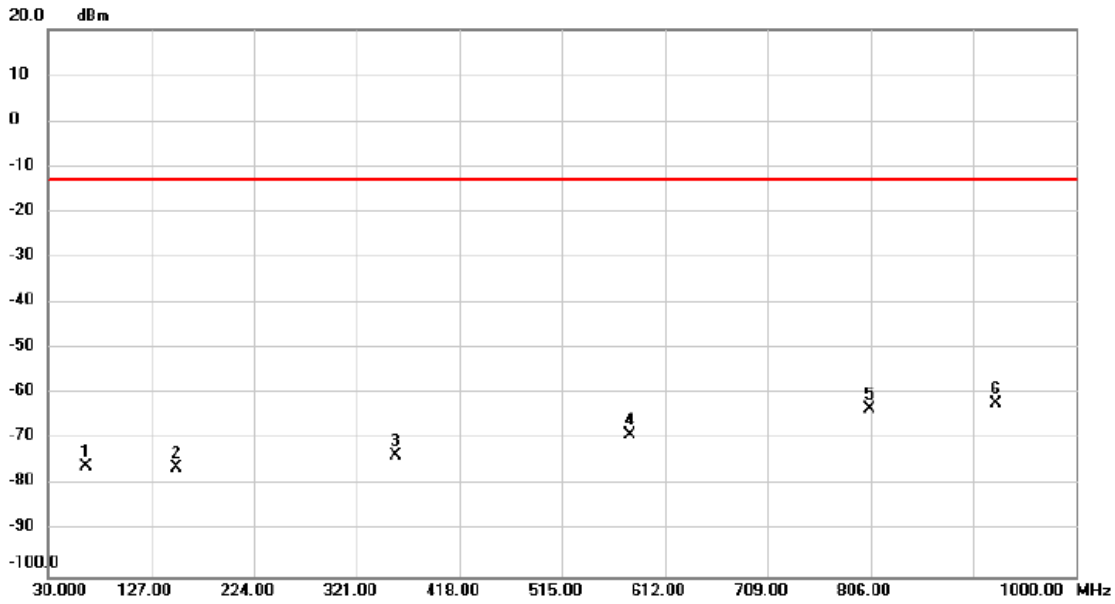

No.	Mk.	Freq. MHz	Reading Level dBm	Correct Factor dB	Measure- ment dBm	Limit dBm	Margin dB	Detector	Comment
1		65.579	-70.15	-5.74	-75.89	-13.00	-62.89	peak	
2		150.643	-73.07	-3.08	-76.15	-13.00	-63.15	peak	
3		358.293	-73.27	-0.32	-73.59	-13.00	-60.59	peak	
4		579.203	-73.28	4.19	-69.09	-13.00	-56.09	peak	
5		805.612	-72.13	8.77	-63.36	-13.00	-50.36	peak	
6	*	923.991	-72.44	10.48	-61.96	-13.00	-48.96	peak	

Test Mode LTE Band 2_QPSK_TX CH18900_15KHz

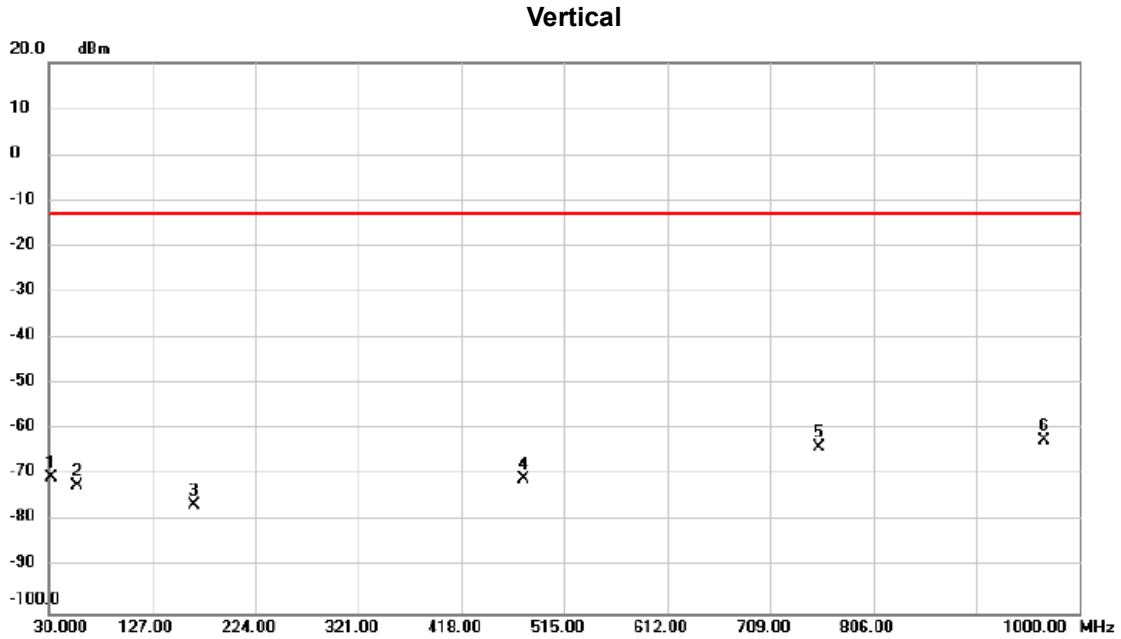

No.	Mk.	Freq. MHz	Reading Level dBm	Correct Factor dB	Measure- ment dBm	Limit dBm	Margin dB	Detector	Comment
1		32.264	-64.70	-5.72	-70.42	-13.00	-57.42	peak	
2		56.199	-67.74	-4.58	-72.32	-13.00	-59.32	peak	
3		166.169	-73.40	-2.99	-76.39	-13.00	-63.39	peak	
4		476.672	-73.10	2.42	-70.68	-13.00	-57.68	peak	
5		755.479	-71.58	7.60	-63.98	-13.00	-50.98	peak	
6	*	967.332	-73.59	11.31	-62.28	-13.00	-49.28	peak	

Test Mode LTE Band 2_QPSK_TX CH18900_15KHz

Horizontal

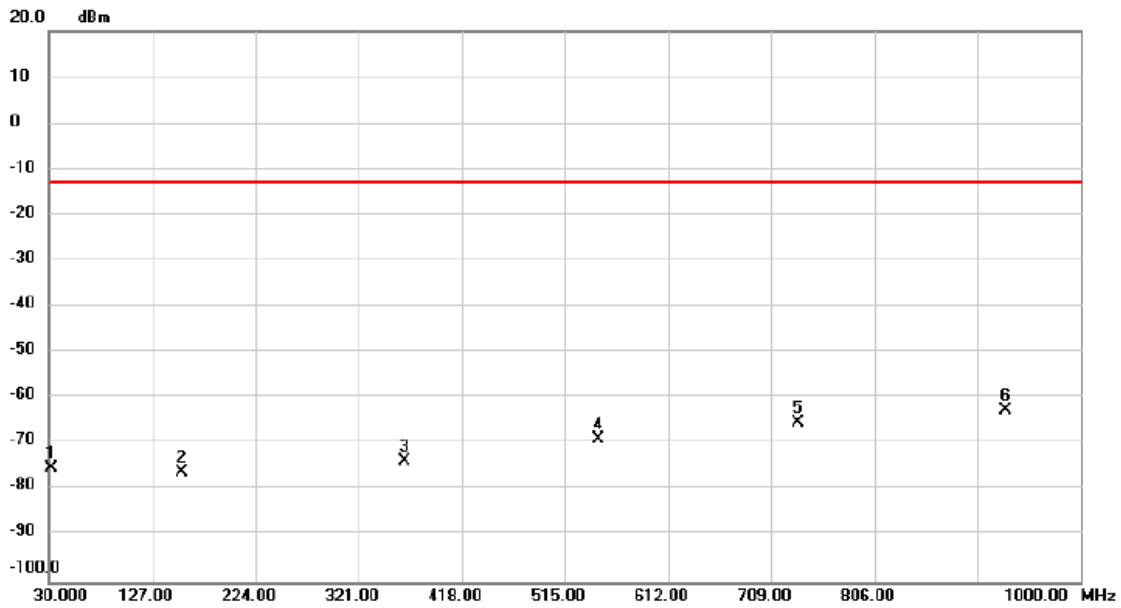

No.	Mk.	Freq. MHz	Reading Level dBm	Correct Factor dB	Measure- ment dBm	Limit dBm	Margin dB	Detector	Comment
1		32.264	-69.55	-5.72	-75.27	-13.00	-62.27	peak	
2		154.525	-73.24	-2.99	-76.23	-13.00	-63.23	peak	
3		363.791	-73.52	-0.19	-73.71	-13.00	-60.71	peak	
4		547.182	-72.31	3.38	-68.93	-13.00	-55.93	peak	
5		734.455	-72.34	7.09	-65.25	-13.00	-52.25	peak	
6	*	929.166	-73.44	10.65	-62.79	-13.00	-49.79	peak	

Test Mode LTE Band 25_BPSK_TX CH26365_3.75KHz

Vertical

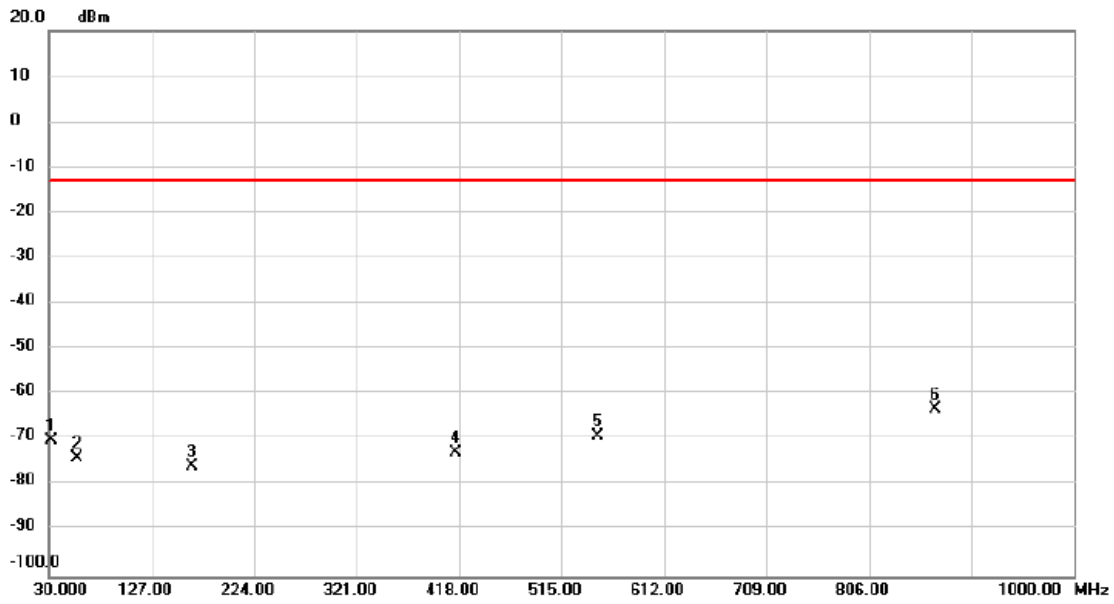

No.	Mk.	Freq. MHz	Reading Level dBm	Correct Factor dB	Measure- ment dBm	Limit dBm	Margin dB	Detector	Comment
1		31.941	-64.44	-5.76	-70.20	-13.00	-57.20	peak	
2		55.875	-69.47	-4.57	-74.04	-13.00	-61.04	peak	
3		165.198	-73.02	-2.96	-75.98	-13.00	-62.98	peak	
4		414.895	-73.98	1.04	-72.94	-13.00	-59.94	peak	
5		549.123	-72.76	3.41	-69.35	-13.00	-56.35	peak	
6	*	869.006	-72.43	9.17	-63.26	-13.00	-50.26	peak	

Test Mode LTE Band 25_BPSK_TX CH26365_3.75KHz

Horizontal

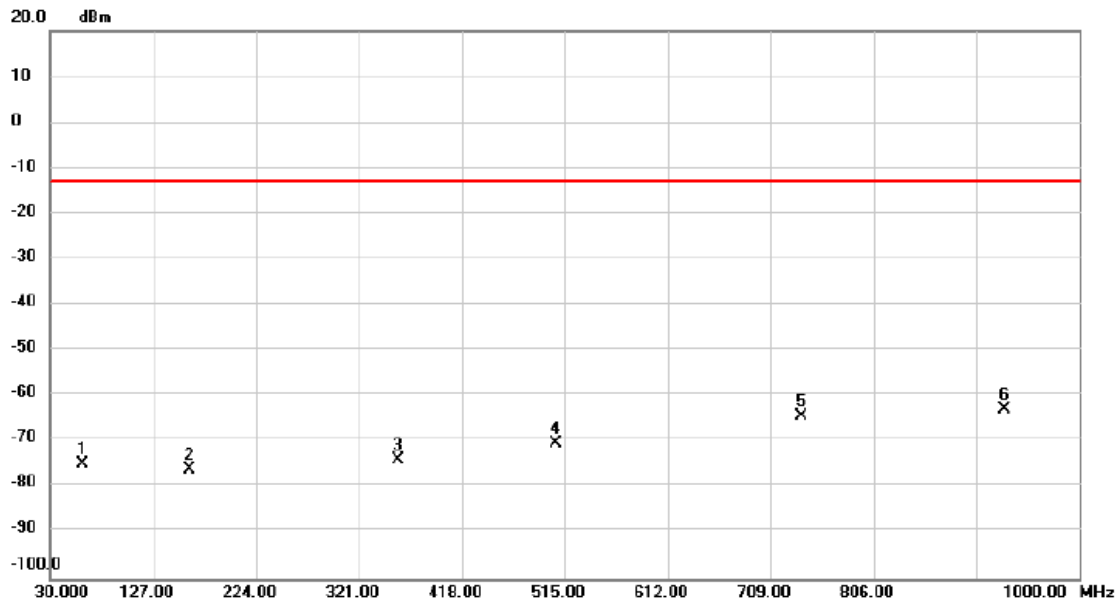

No.	Mk.	Freq. MHz	Reading Level dBm	Correct Factor dB	Measure- ment dBm	Limit dBm	Margin dB	Detector	Comment
1		60.404	-70.09	-4.94	-75.03	-13.00	-62.03	peak	
2		160.670	-73.23	-2.86	-76.09	-13.00	-63.09	peak	
3		357.646	-73.74	-0.34	-74.08	-13.00	-61.08	peak	
4		506.429	-73.39	2.89	-70.50	-13.00	-57.50	peak	
5		738.336	-71.57	7.19	-64.38	-13.00	-51.38	peak	
6	*	929.166	-73.50	10.65	-62.85	-13.00	-49.85	peak	

Test Mode LTE Band 25_BPSK_TX CH26365_15KHz

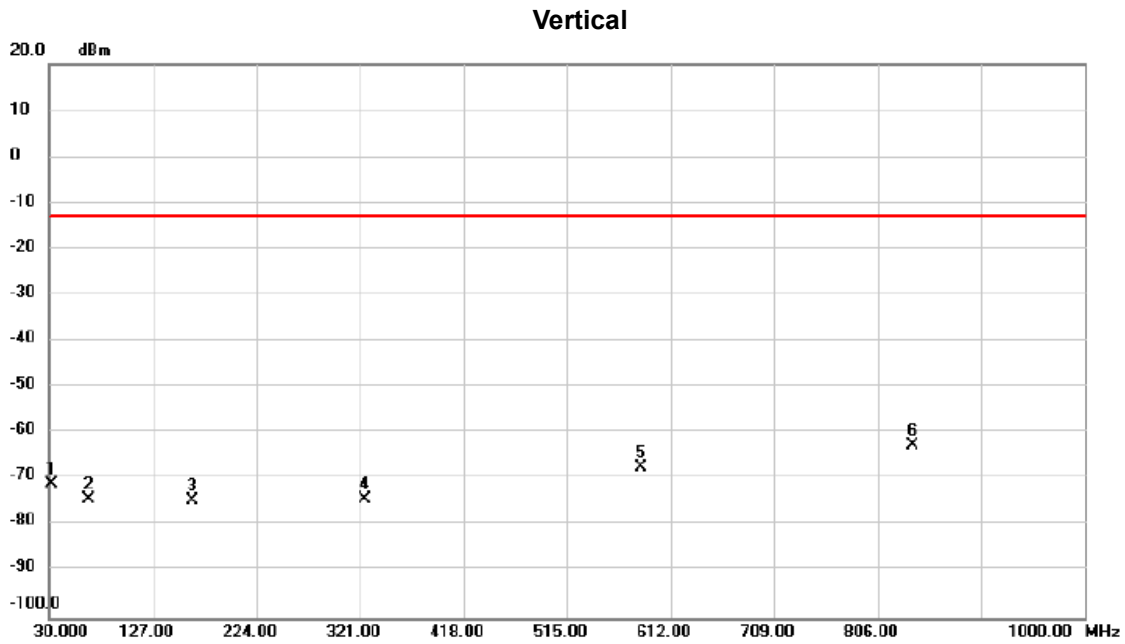

No.	Mk.	Freq. MHz	Reading Level dBm	Correct Factor dB	Measure- ment dBm	Limit dBm	Margin dB	Detector	Comment
1		32.264	-65.37	-5.72	-71.09	-13.00	-58.09	peak	
2		66.225	-68.33	-5.88	-74.21	-13.00	-61.21	peak	
3		164.228	-71.59	-2.94	-74.53	-13.00	-61.53	peak	
4		325.949	-73.28	-0.94	-74.22	-13.00	-61.22	peak	
5		584.702	-71.72	4.33	-67.39	-13.00	-54.39	peak	
6	*	839.573	-71.59	8.80	-62.79	-13.00	-49.79	peak	

Test Mode LTE Band 25_BPSK_TX CH26365_15KHz

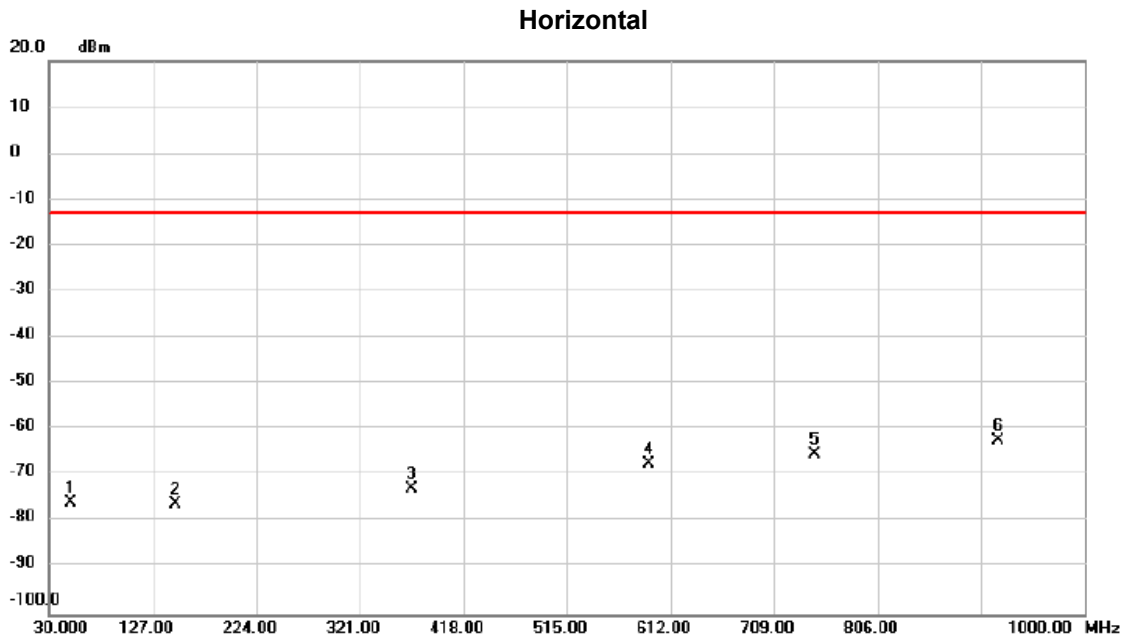

No.	Mk.	Freq. MHz	Reading Level dBm	Correct Factor dB	Measure- ment dBm	Limit dBm	Margin dB	Detector	Comment
1		49.730	-71.74	-4.10	-75.84	-13.00	-62.84	peak	
2		148.056	-72.94	-3.15	-76.09	-13.00	-63.09	peak	
3		369.613	-72.66	-0.06	-72.72	-13.00	-59.72	peak	
4		591.817	-72.08	4.52	-67.56	-13.00	-54.56	peak	
5		747.716	-72.84	7.41	-65.43	-13.00	-52.43	peak	
6	*	918.816	-72.61	10.34	-62.27	-13.00	-49.27	peak	

Test Mode LTE Band 25_QPSK_TX CH26365_3.75KHz

Vertical

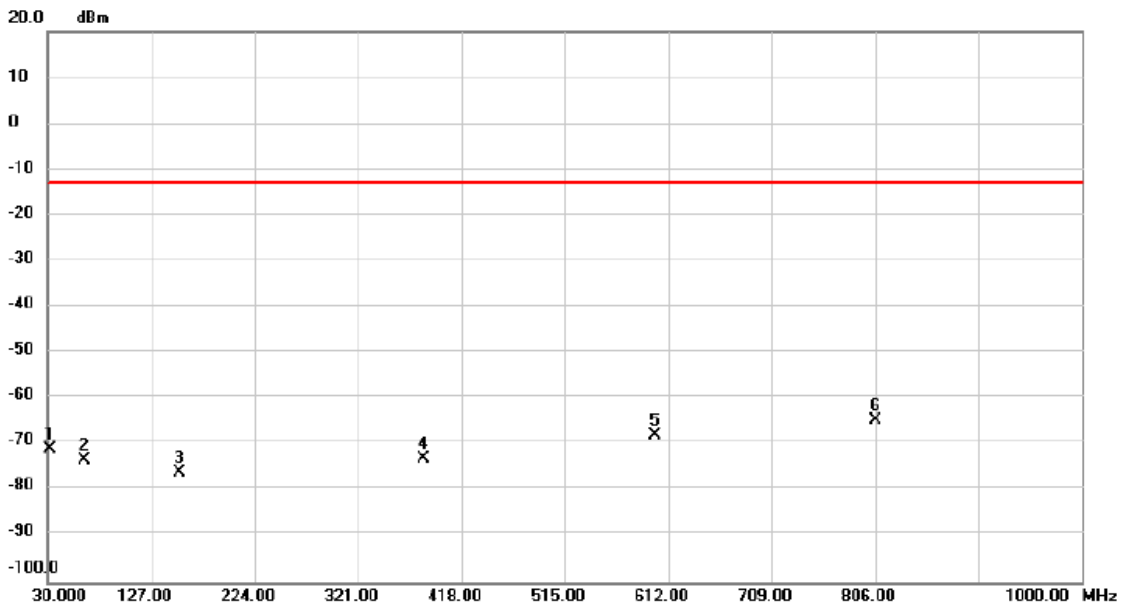

No.	Mk.	Freq. MHz	Reading Level dBm	Correct Factor dB	Measure- ment dBm	Limit dBm	Margin dB	Detector	Comment
1		32.264	-65.28	-5.72	-71.00	-13.00	-58.00	peak	
2		64.608	-67.95	-5.57	-73.52	-13.00	-60.52	peak	
3		153.878	-73.09	-3.00	-76.09	-13.00	-63.09	peak	
4		382.874	-73.24	0.24	-73.00	-13.00	-60.00	peak	
5		599.256	-72.65	4.72	-67.93	-13.00	-54.93	peak	
6	*	807.229	-73.37	8.76	-64.61	-13.00	-51.61	peak	

Test Mode LTE Band 25_QPSK_TX CH26365_3.75KHz

Horizontal

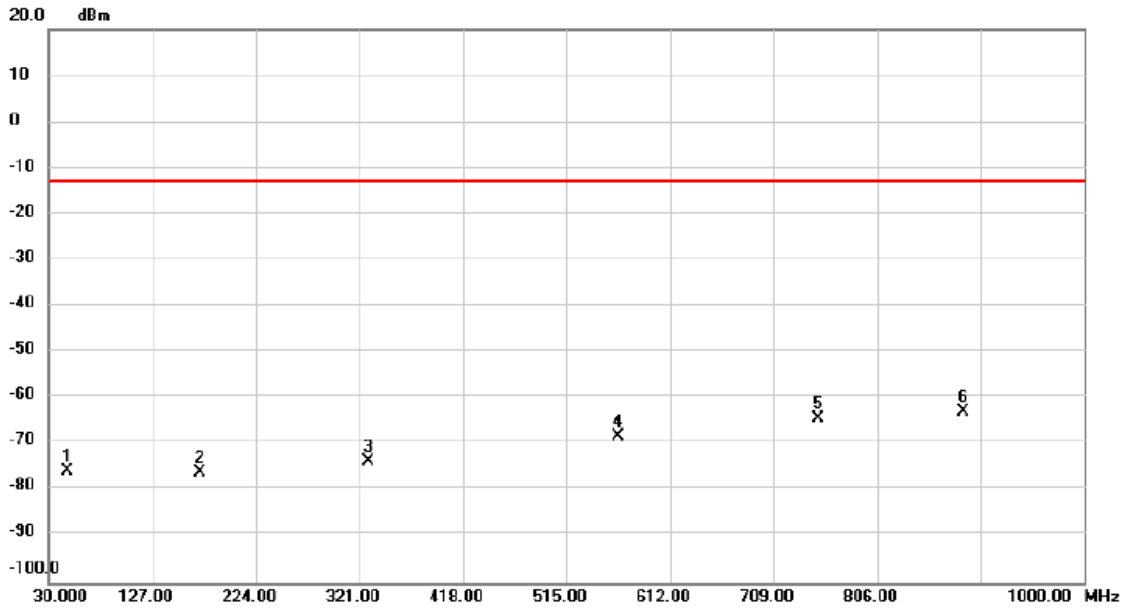

No.	Mk.	Freq. MHz	Reading Level dBm	Correct Factor dB	Measure- ment dBm	Limit dBm	Margin dB	Detector	Comment
1		47.142	-71.73	-4.26	-75.99	-13.00	-62.99	peak	
2		171.020	-73.05	-3.17	-76.22	-13.00	-63.22	peak	
3		329.830	-72.77	-0.89	-73.66	-13.00	-60.66	peak	
4		564.001	-72.06	3.80	-68.26	-13.00	-55.26	peak	
5		751.597	-71.97	7.50	-64.47	-13.00	-51.47	peak	
6	*	887.442	-72.54	9.51	-63.03	-13.00	-50.03	peak	

Test Mode LTE Band 25_QPSK_TX CH26365_15KHz

Vertical

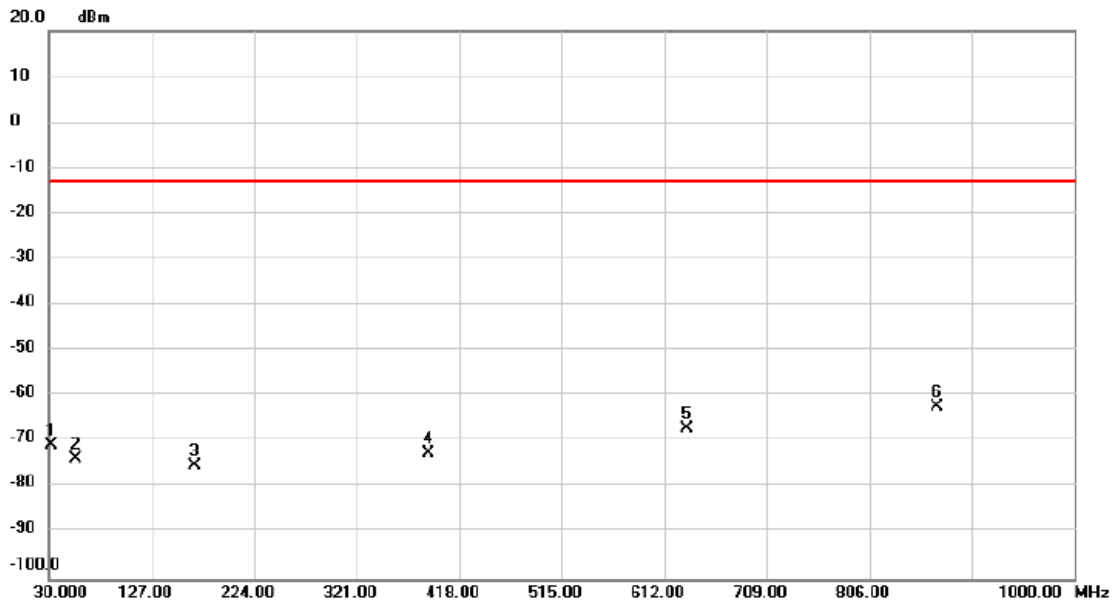

No.	Mk.	Freq. MHz	Reading Level dBm	Correct Factor dB	Measure- ment dBm	Limit dBm	Margin dB	Detector	Comment
1		31.941	-65.12	-5.76	-70.88	-13.00	-57.88	peak	
2		55.552	-69.09	-4.56	-73.65	-13.00	-60.65	peak	
3		168.109	-72.26	-3.01	-75.27	-13.00	-62.27	peak	
4		388.696	-73.03	0.38	-72.65	-13.00	-59.65	peak	
5		633.865	-72.41	5.32	-67.09	-13.00	-54.09	peak	
6	*	870.300	-71.58	9.20	-62.38	-13.00	-49.38	peak	

Test Mode LTE Band 25_QPSK_TX CH26365_15KHz

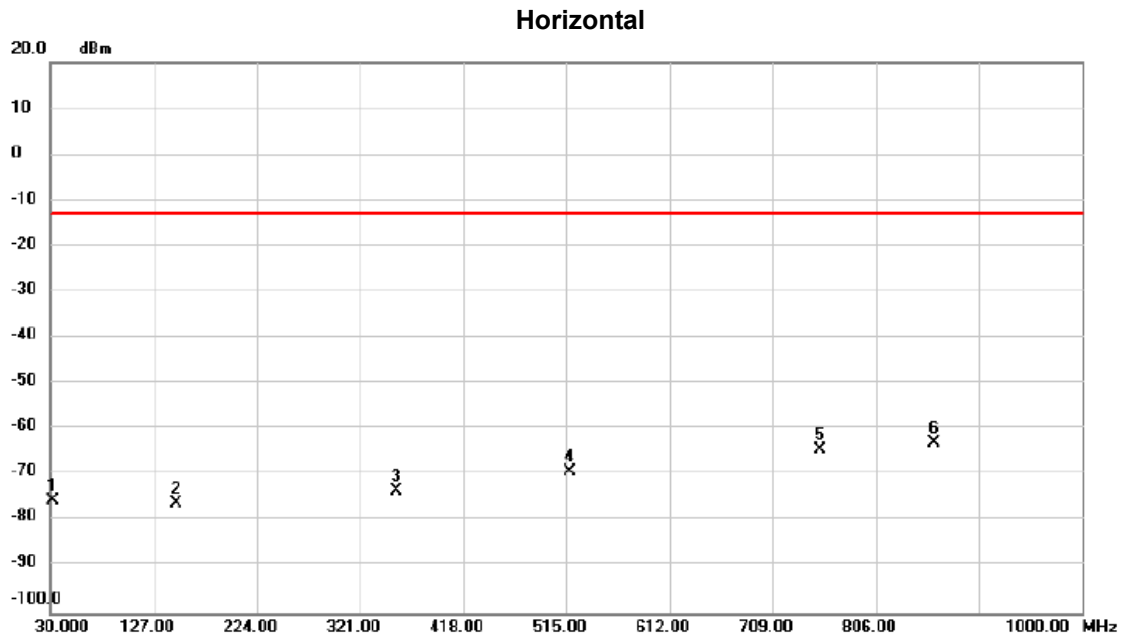

No.	Mk.	Freq. MHz	Reading Level dBm	Correct Factor dB	Measure- ment dBm	Limit dBm	Margin dB	Detector	Comment
1		31.941	-69.73	-5.76	-75.49	-13.00	-62.49	peak	
2		147.733	-72.97	-3.16	-76.13	-13.00	-63.13	peak	
3		354.735	-73.10	-0.40	-73.50	-13.00	-60.50	peak	
4		518.396	-72.15	3.03	-69.12	-13.00	-56.12	peak	
5		753.214	-71.90	7.54	-64.36	-13.00	-51.36	peak	
6	*	860.920	-72.11	9.02	-63.09	-13.00	-50.09	peak	

APPENDIX F - RADIATED SPURIOUS EMISSIONS (ABOVE 1000MHZ)

Test Mode LTE Band 2_BPSK_TX CH18900_3.75KHz

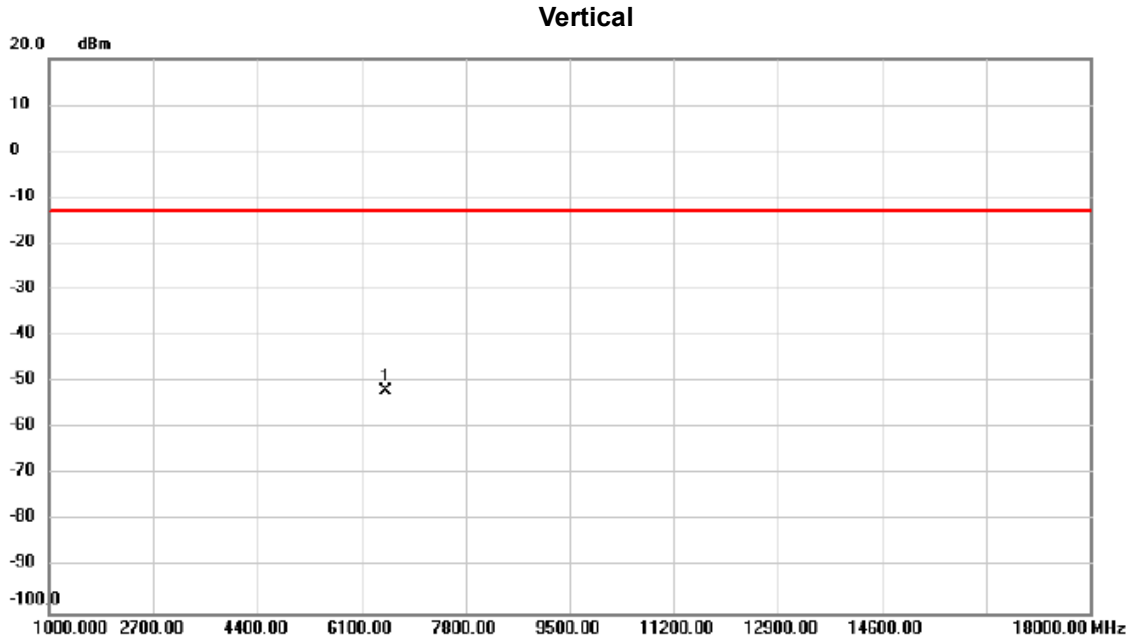

No.	Mk.	Freq.	Reading Level	Correct Factor	Measurement	Limit	Margin	Detector	Comment
		MHz	dBm	dB	dBm	dBm	dB		
1	*	6499.500	-71.47	19.64	-51.83	-13.00	-38.83	peak	

Test Mode | LTE Band 2_BPSK_TX CH18900_3.75KHz

Horizontal

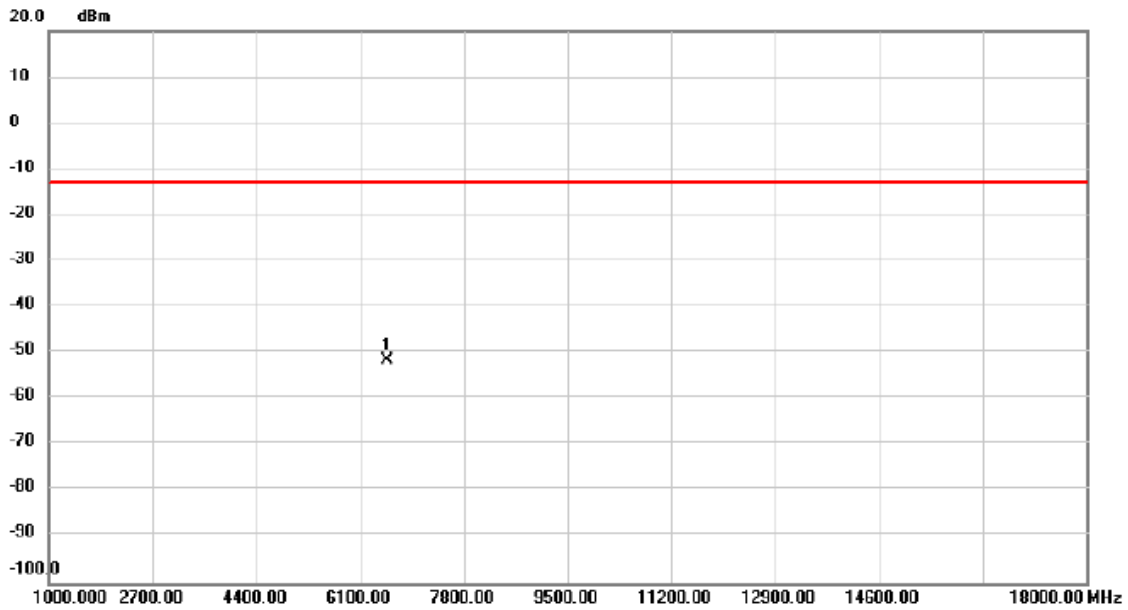

No. Mk.	Freq. MHz	Reading Level dBm	Correct Factor dB	Measure- ment dBm	Limit dBm	Margin dB	Detector	Comment
1 *	6533.500	-71.29	19.80	-51.49	-13.00	-38.49	peak	

Test Mode LTE Band 2_BPSK_TX CH18900_15KHz

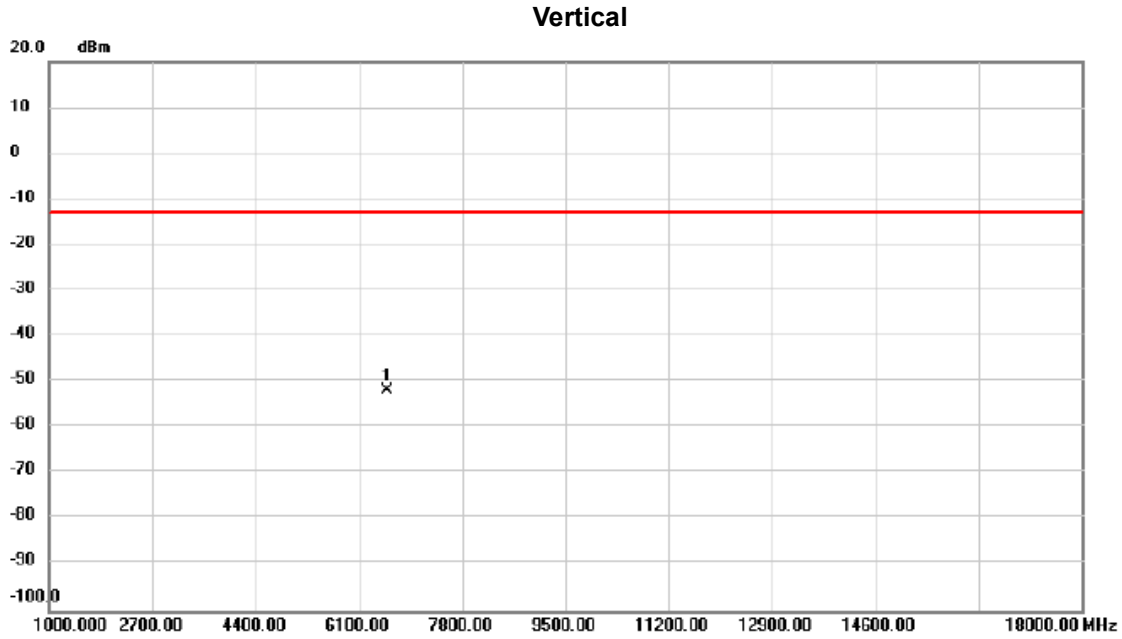

No.	Mk.	Freq.	Reading Level	Correct Factor	Measurement	Limit	Margin	Detector	Comment
		MHz	dBm	dB	dBm	dBm	dB		
1	*	6559.000	-71.82	19.92	-51.90	-13.00	-38.90	peak	

Test Mode | LTE Band 2_BPSK_TX CH18900_15KHz

Horizontal

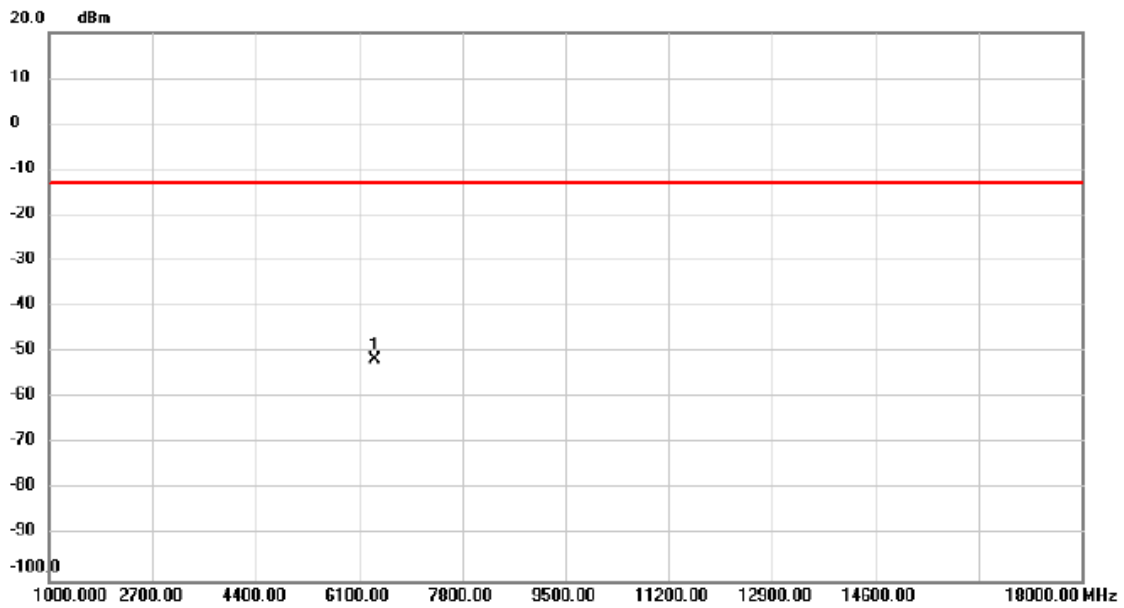

No. Mk.	Freq. MHz	Reading Level dBm	Correct Factor dB	Measure- ment dBm	Limit dBm	Margin dB	Detector	Comment
1 *	6363.500	-71.07	19.39	-51.68	-13.00	-38.68	peak	

Test Mode LTE Band 2_QPSK_TX CH18900_3.75KHz

Vertical

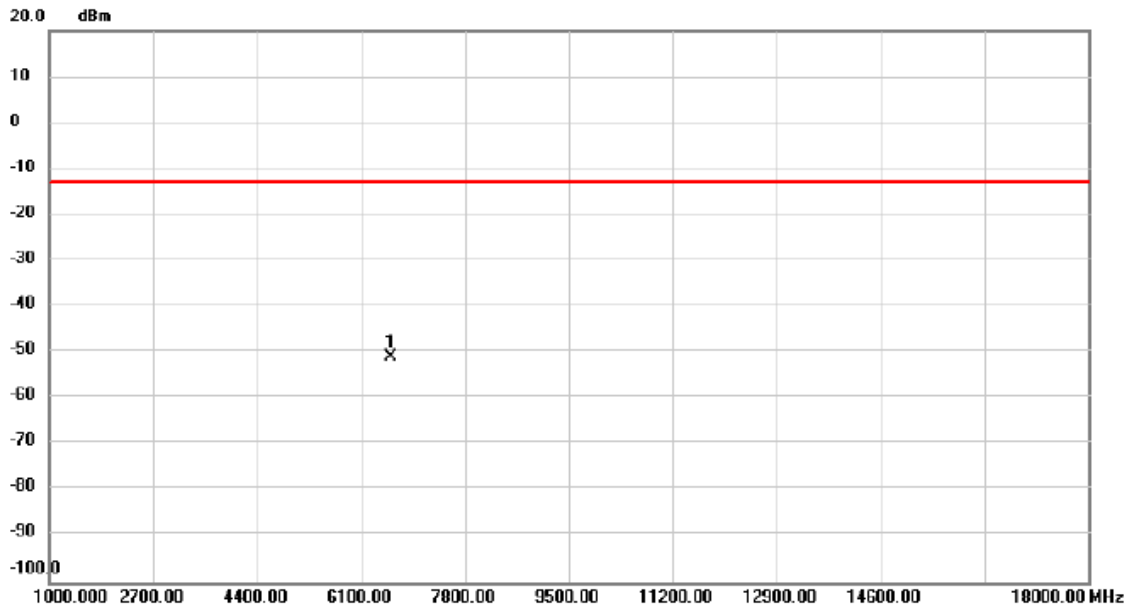

No. Mk.	Freq. MHz	Reading Level dBm	Correct Factor dB	Measure- ment dBm	Limit dBm	Margin dB	Detector	Comment
1 *	6576.000	-71.00	20.00	-51.00	-13.00	-38.00	peak	

Test Mode LTE Band 2_QPSK_TX CH18900_3.75KHz

Horizontal

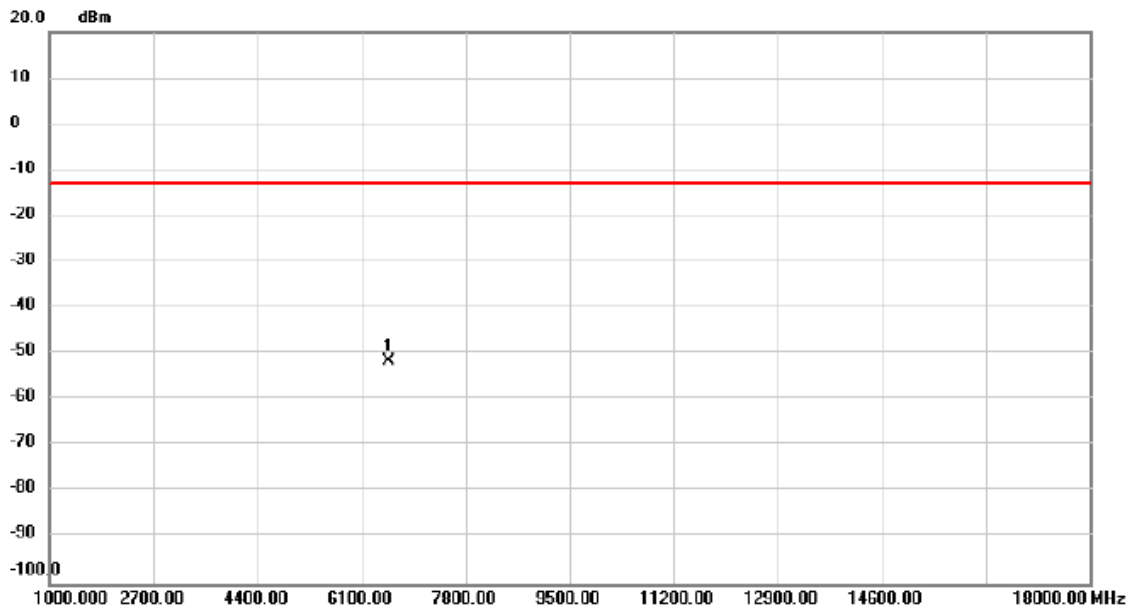

No.	Mk.	Freq. MHz	Reading Level dBm	Correct Factor dB	Measure- ment dBm	Limit dBm	Margin dB	Detector	Comment
1	*	6533.500	-71.35	19.80	-51.55	-13.00	-38.55	peak	

Test Mode LTE Band 2_QPSK_TX CH18900_15KHz

Vertical

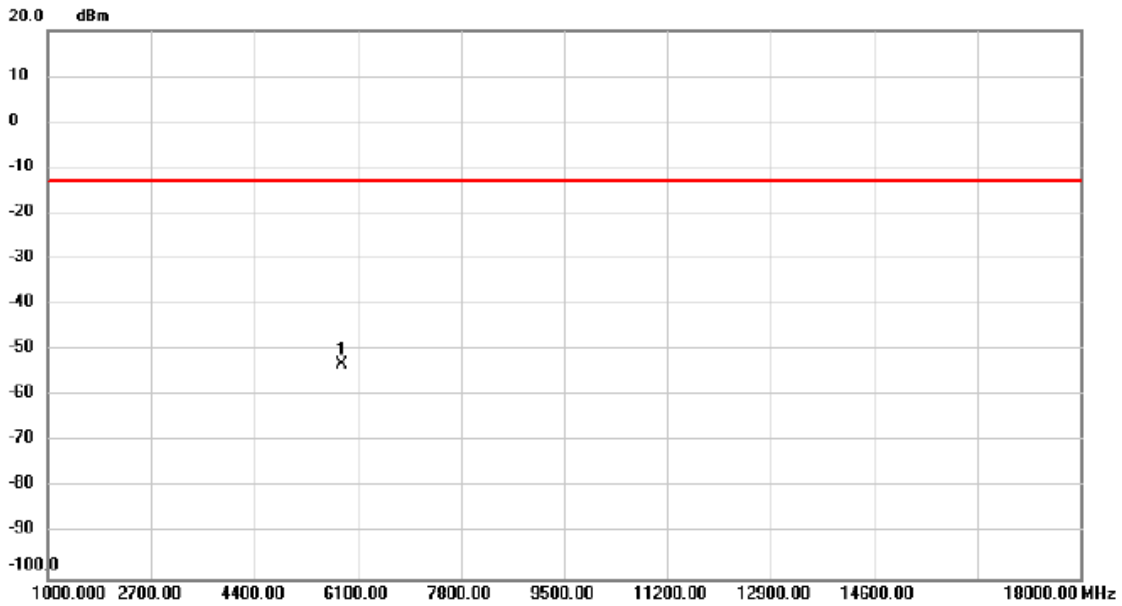

No.	Mk.	Freq.	Reading Level	Correct Factor	Measurement	Limit	Margin	Detector	Comment
		MHz	dBm	dB	dBm	dBm	dB		
1	*	5836.500	-71.71	18.60	-53.11	-13.00	-40.11	peak	

Test Mode LTE Band 2_QPSK_TX CH18900_15KHz

Horizontal

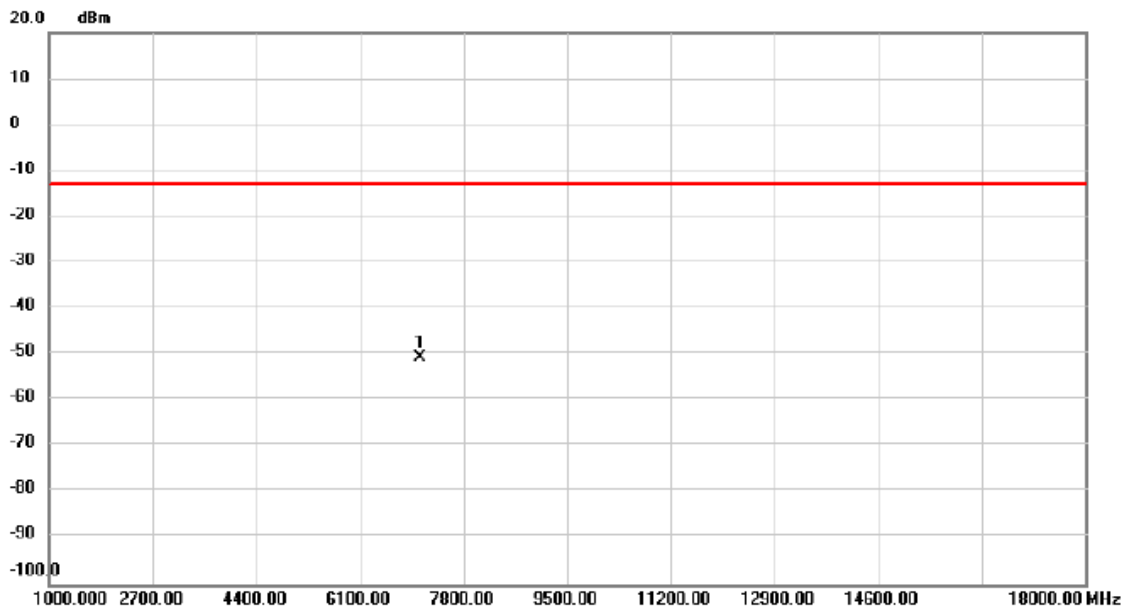

No. Mk.	Freq. MHz	Reading Level dBm	Correct Factor dB	Measure- ment dBm	Limit dBm	Margin dB	Detector	Comment
1 *	7094.500	-72.88	22.15	-50.73	-13.00	-37.73	peak	

Test Mode: LTE Band 2_BPSK_TX CH18900_3.75KHz

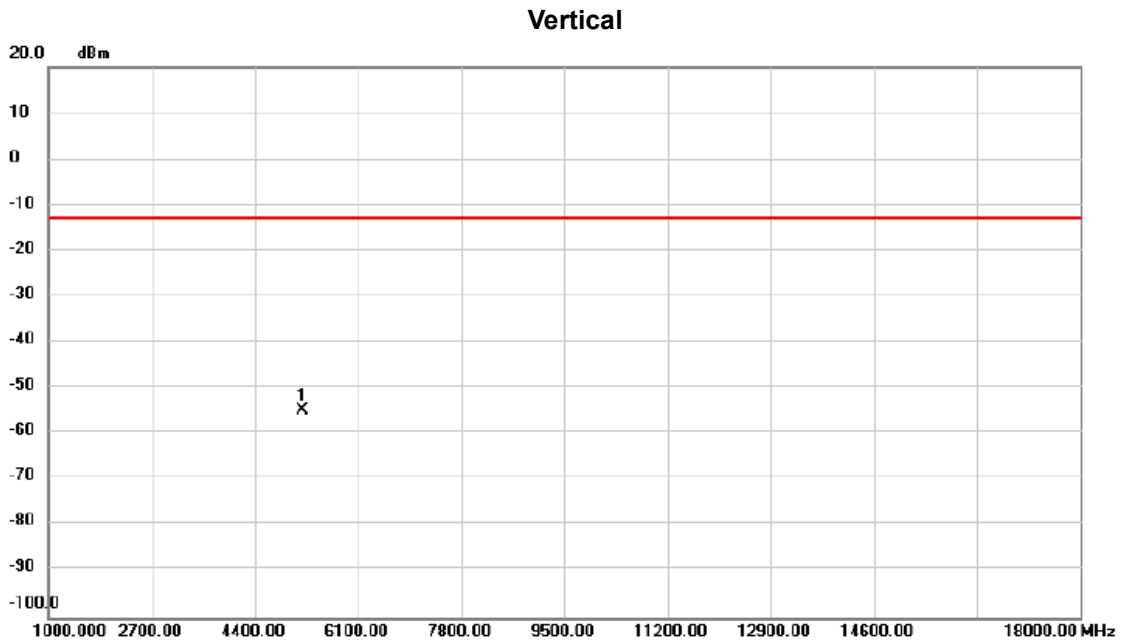

No.	Mk.	Freq. MHz	Reading Level dBm	Correct Factor dB	Measure- ment dBm	Limit dBm	Margin dB	Detector	Comment
1	*	5182.000	-72.90	18.06	-54.84	-13.00	-41.84	peak	

Test Mode LTE Band 25_BPSK_TX CH26365_3.75KHz

Horizontal

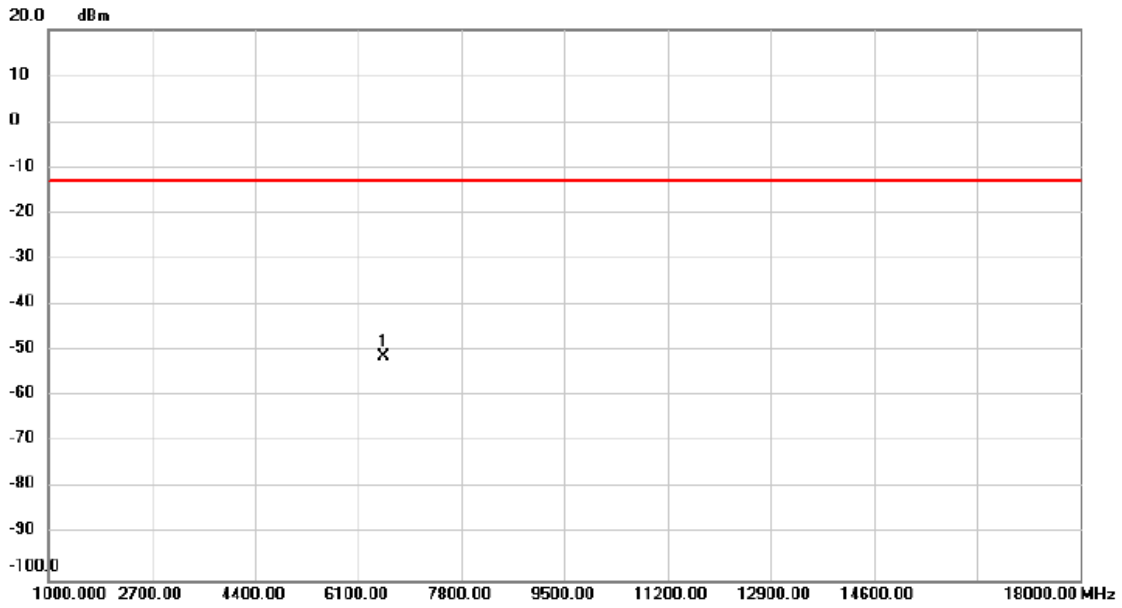

No.	Mk.	Freq.	Reading Level	Correct Factor	Measurement	Limit	Margin	Detector	Comment
		MHz	dBm	dB	dBm	dBm	dB		
1	*	6525.000	-71.08	19.76	-51.32	-13.00	-38.32	peak	

Test Mode | LTE Band 25_BPSK_TX CH26365_15KHz

Vertical

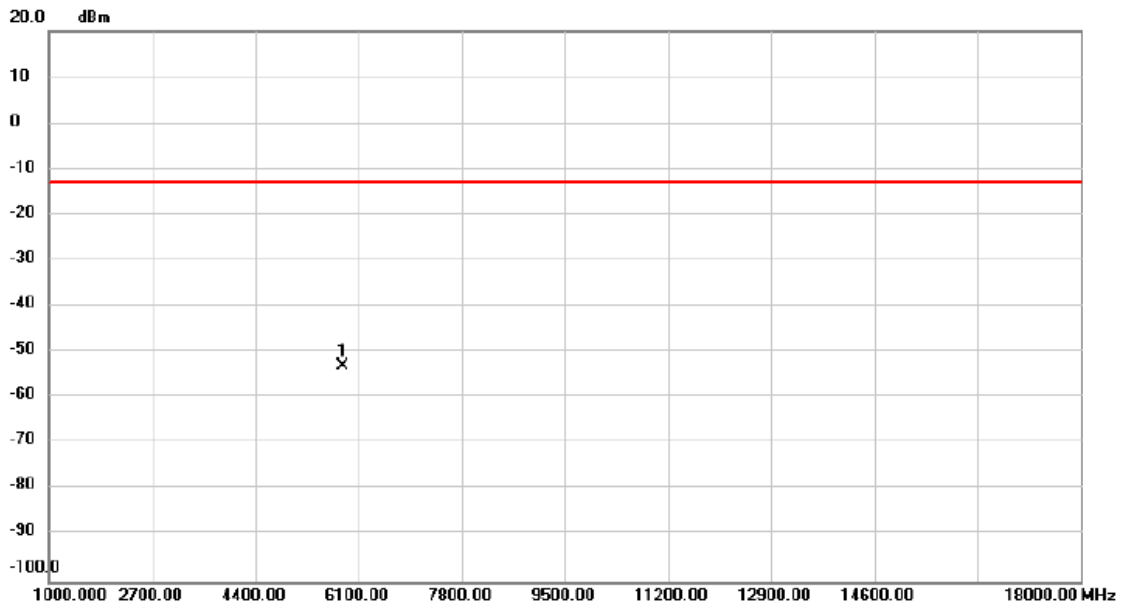

No.	Mk.	Freq.	Reading Level	Correct Factor	Measurement	Limit	Margin	Detector	Comment
		MHz	dBm	dB	dBm	dBm	dB		
1	*	5845.000	-71.73	18.61	-53.12	-13.00	-40.12	peak	

Test Mode | LTE Band 25_BPSK_TX CH26365_15KHz

Horizontal

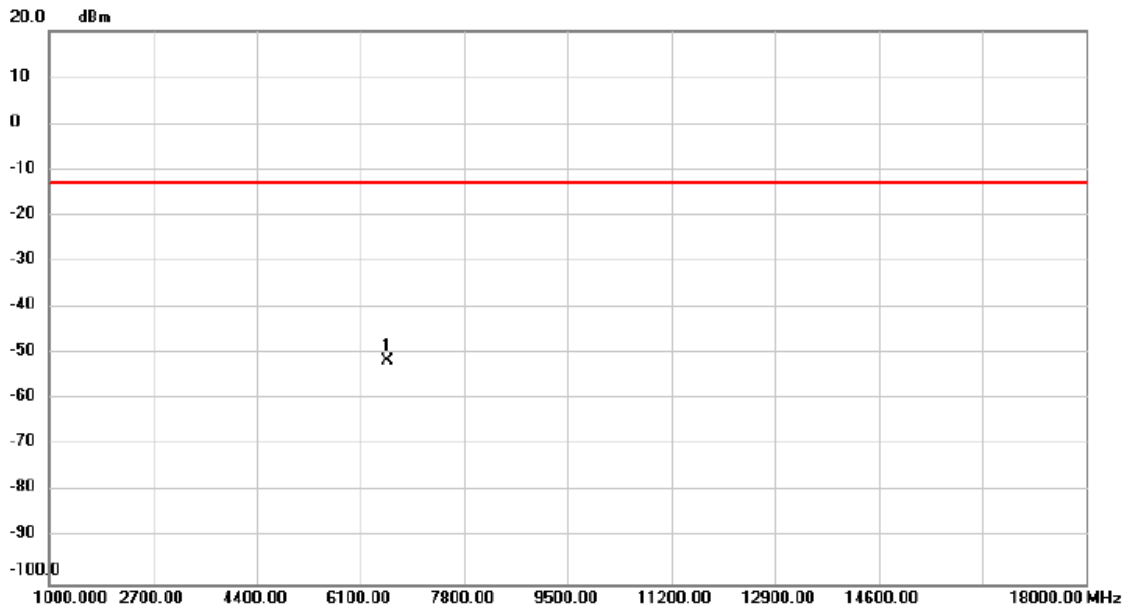

No. Mk.	Freq. MHz	Reading Level dBm	Correct Factor dB	Measure- ment dBm	Limit dBm	Margin dB	Detector	Comment
1 *	6542.000	-71.48	19.84	-51.64	-13.00	-38.64	peak	

Test Mode LTE Band 25_QPSK_TX CH26365_3.75KHz

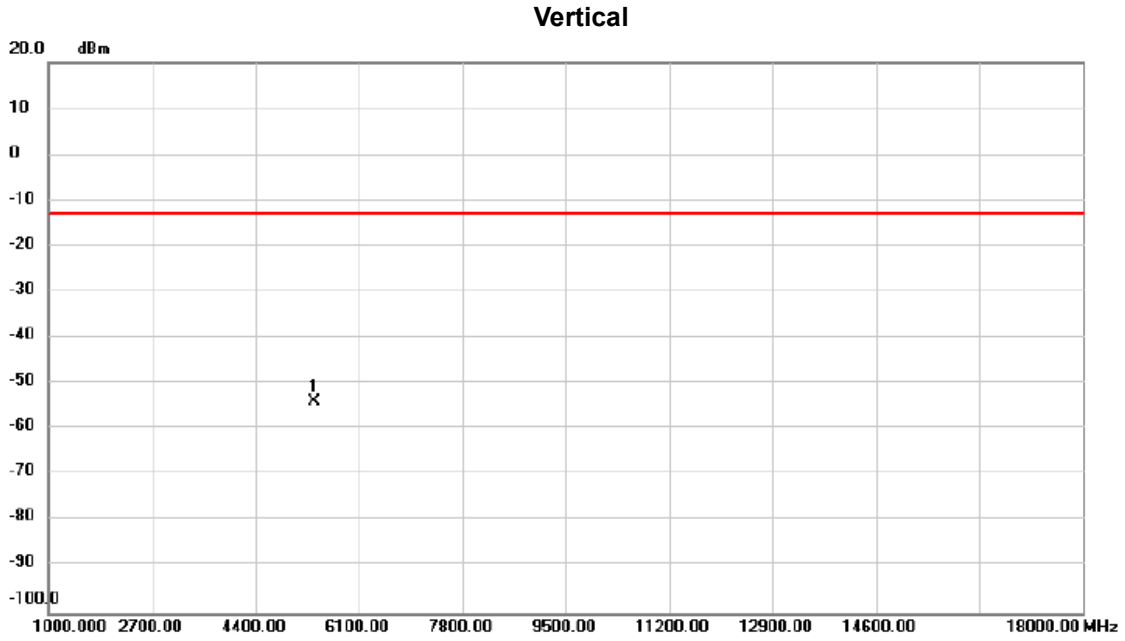

No. Mk.	Freq. MHz	Reading Level dBm	Correct Factor dB	Measure- ment dBm	Limit dBm	Margin dB	Detector	Comment
1 *	5360.500	-72.24	18.25	-53.99	-13.00	-40.99	peak	

Test Mode LTE Band 25_QPSK_TX CH26365_3.75KHz

Horizontal

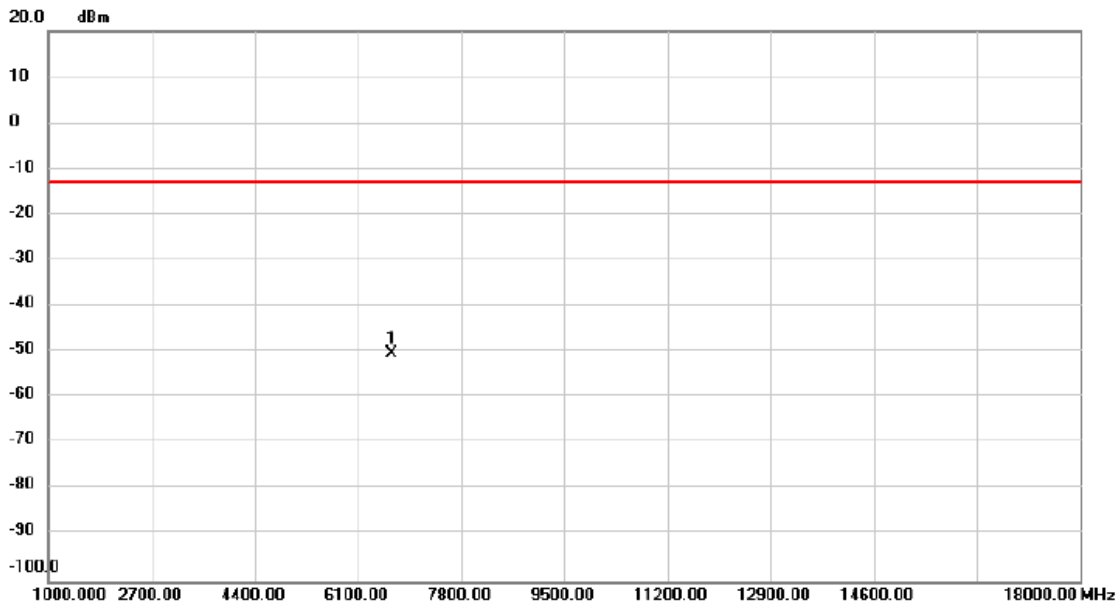

No.	Mk.	Freq.	Reading Level	Correct Factor	Measurement	Limit	Margin	Detector	Comment
		MHz	dBm	dB	dBm	dBm	dB		
1	*	6652.500	-70.80	20.37	-50.43	-13.00	-37.43	peak	

Test Mode LTE Band 25_QPSK_TX CH26365_15KHz

Vertical

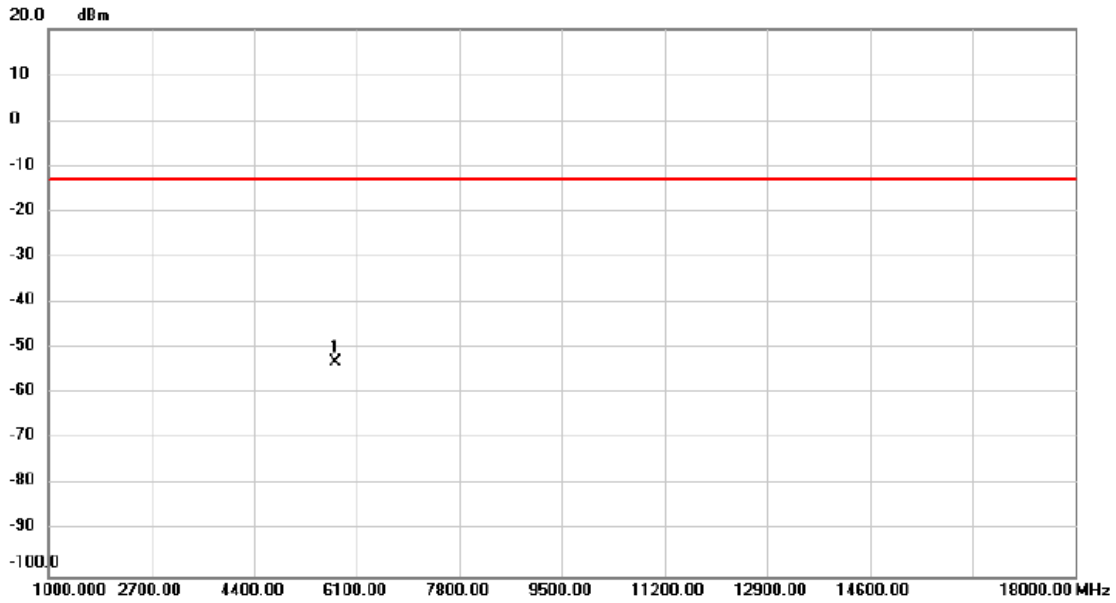

No.	Mk.	Freq.	Reading Level	Correct Factor	Measurement	Limit	Margin	Detector	Comment
		MHz	dBm	dB	dBm	dBm	dB		
1	*	5743.000	-71.60	18.54	-53.06	-13.00	-40.06	peak	

Test Mode | LTE Band 25_QPSK_TX CH26365_15KHz

Horizontal

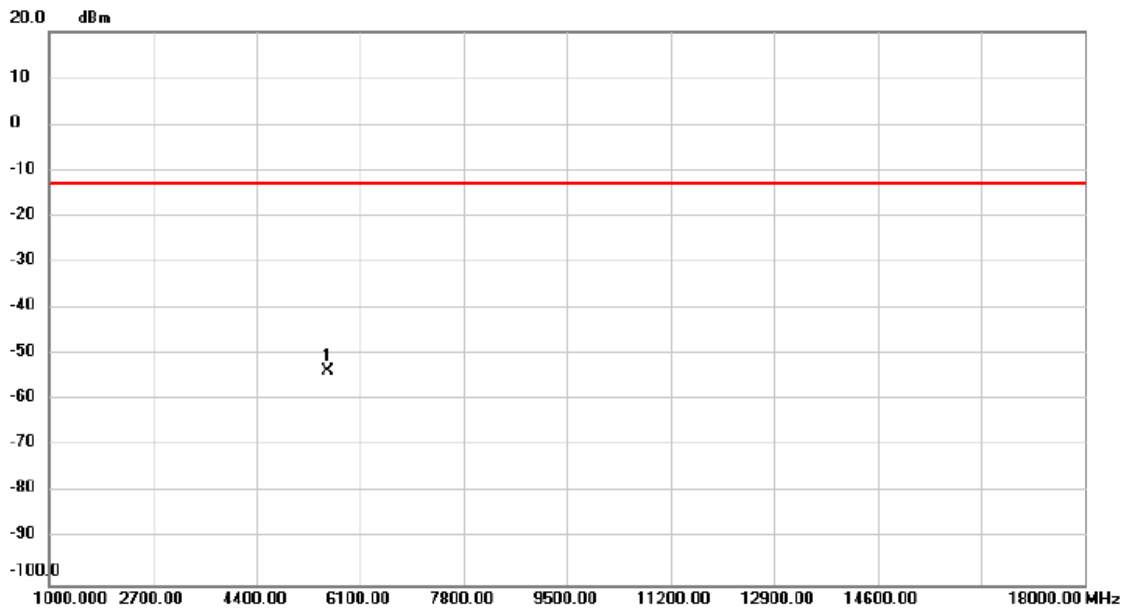

No.	Mk.	Freq.	Reading Level	Correct Factor	Measurement	Limit	Margin	Detector	Comment
		MHz	dBm	dB	dBm	dBm	dB		
1	*	5556.000	-71.97	18.44	-53.53	-13.00	-40.53	peak	

APPENDIX G - BAND EDGE

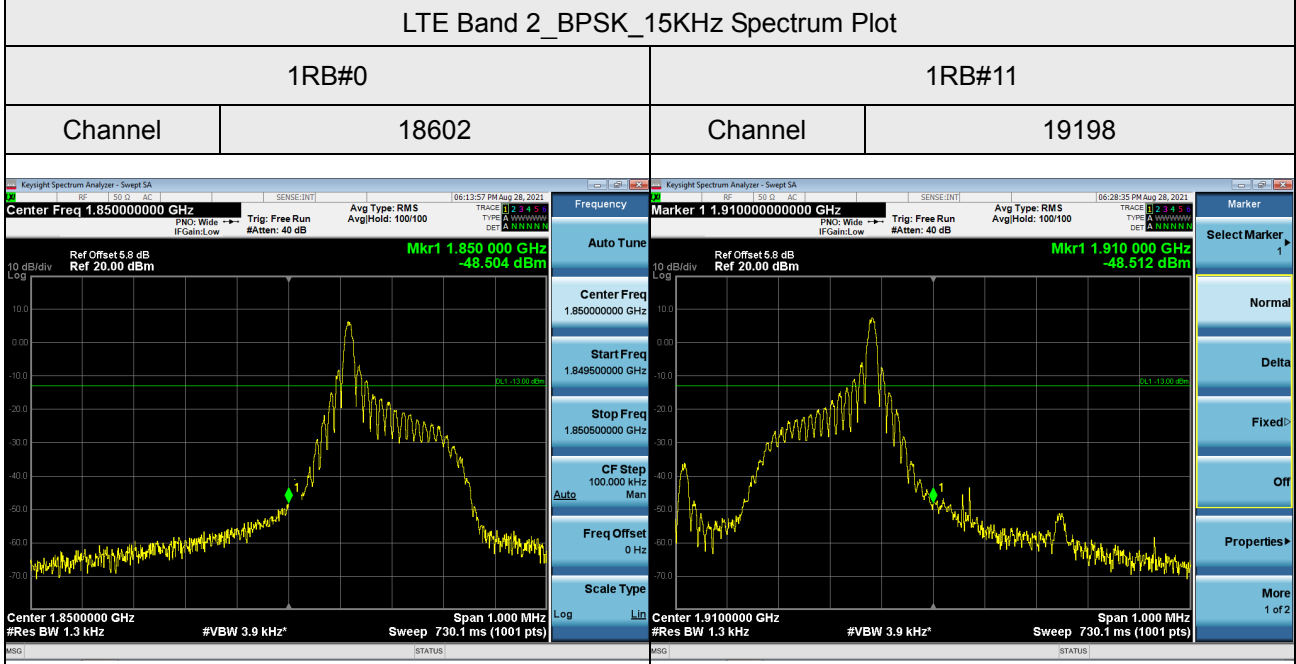
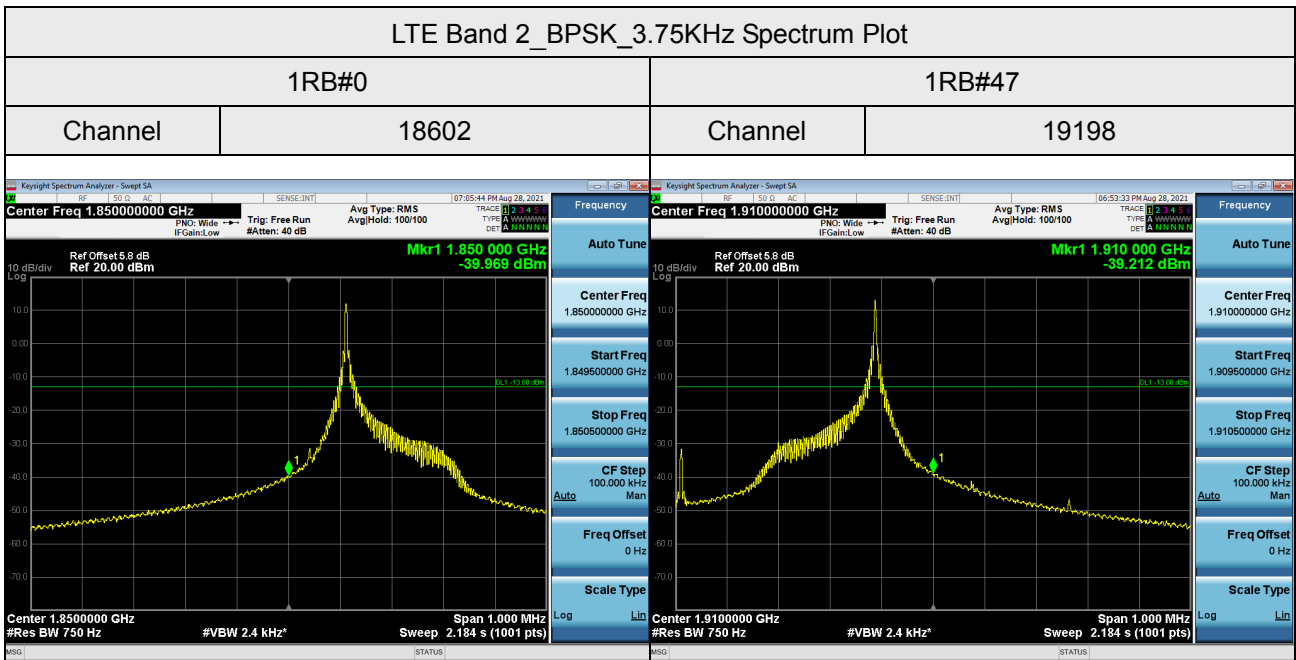

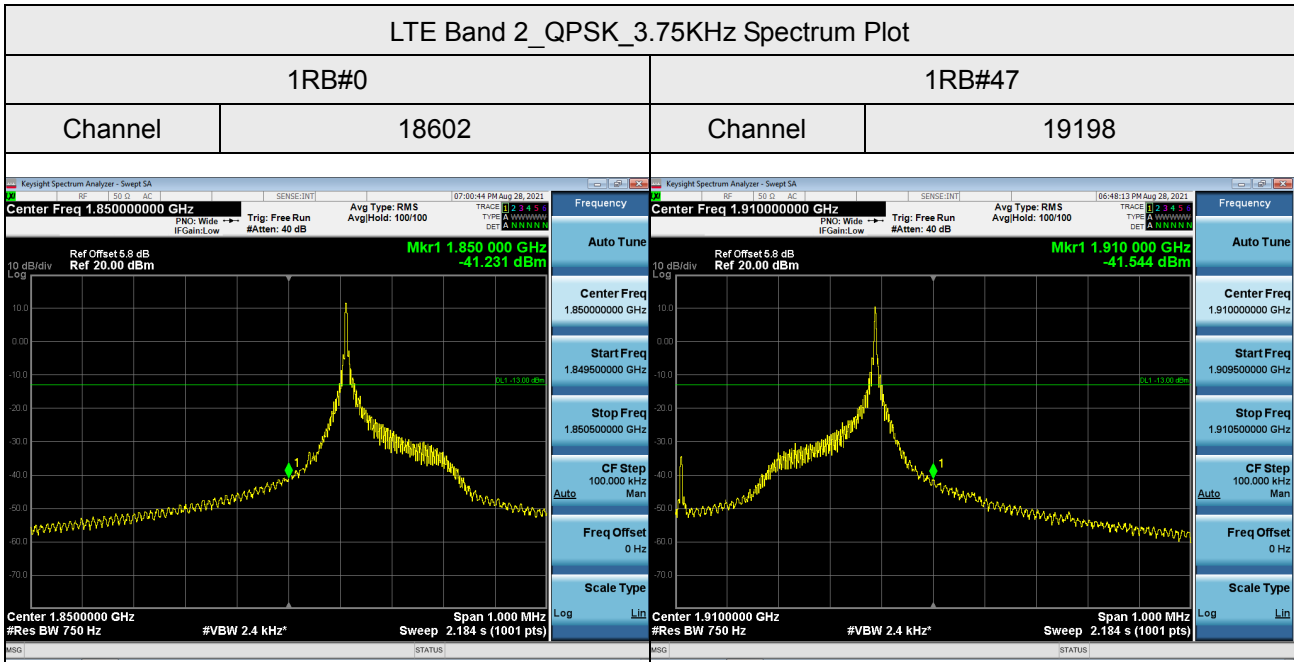

LTE Band 2_QPSK_15KHz Spectrum Plot

1RB#0

1RB#11

Channel

18602

Channel

19198

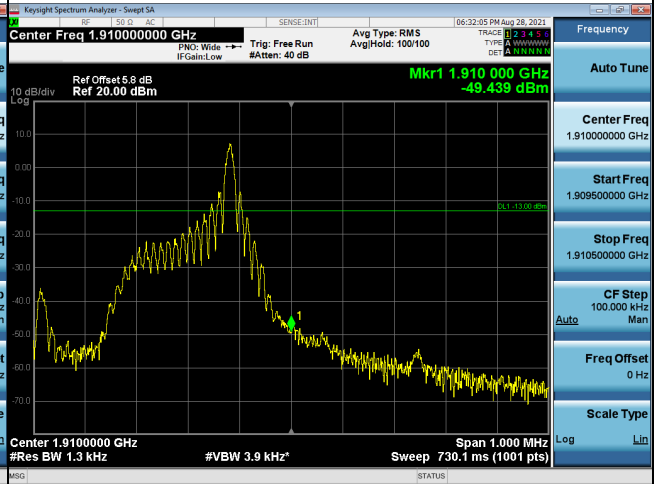
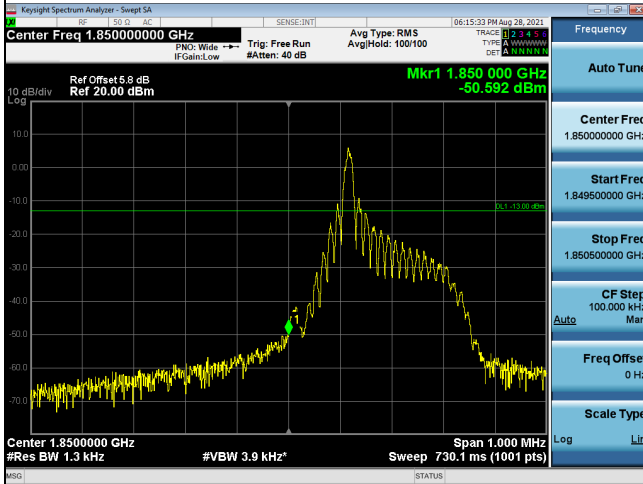

12RB#0

Channel

18602

Channel

19198

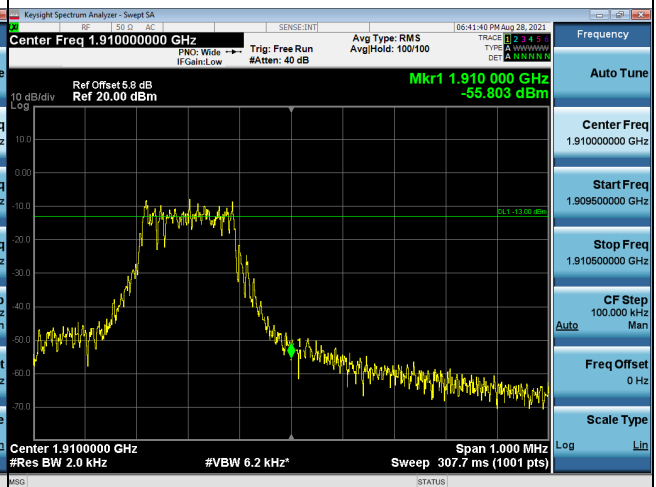
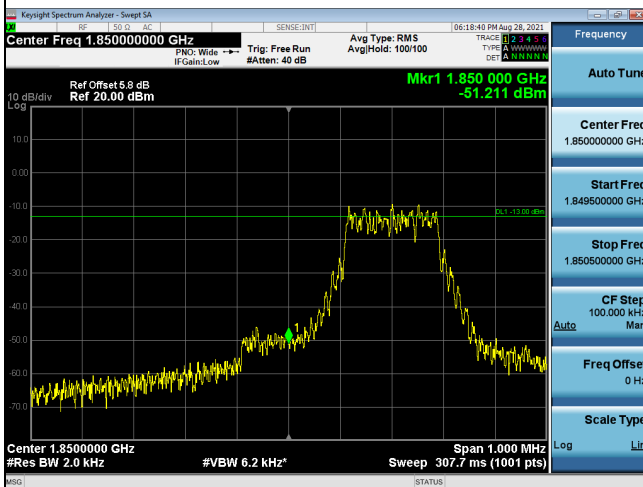

LTE Band 25_BPSK_3.75KHz Spectrum Plot

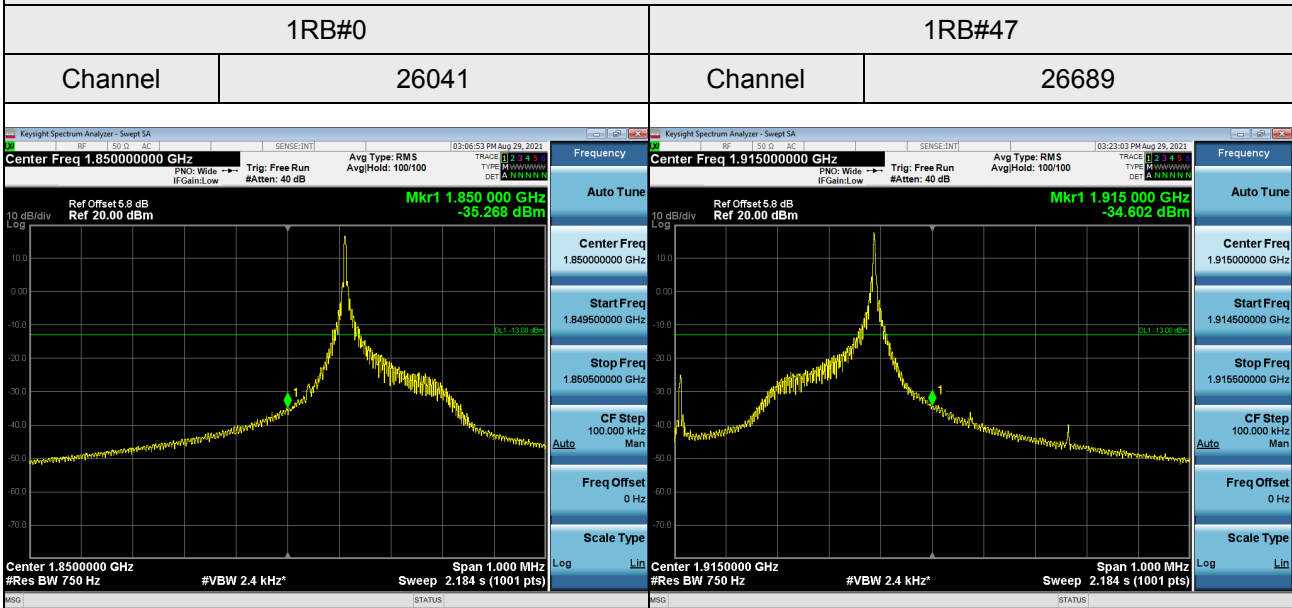

LTE Band 25_BPSK_15KHz Spectrum Plot

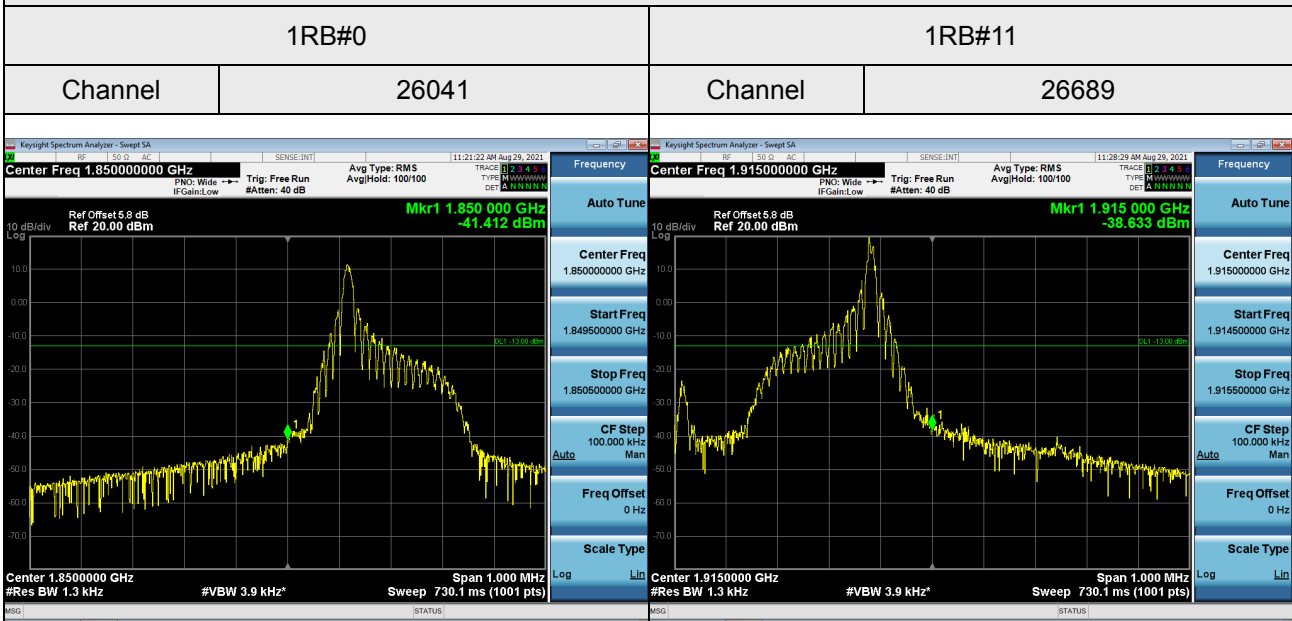

LTE Band 25_QPSK_3.75KHz Spectrum Plot

1RB#0

1RB#47

Channel

26041

Channel

26689

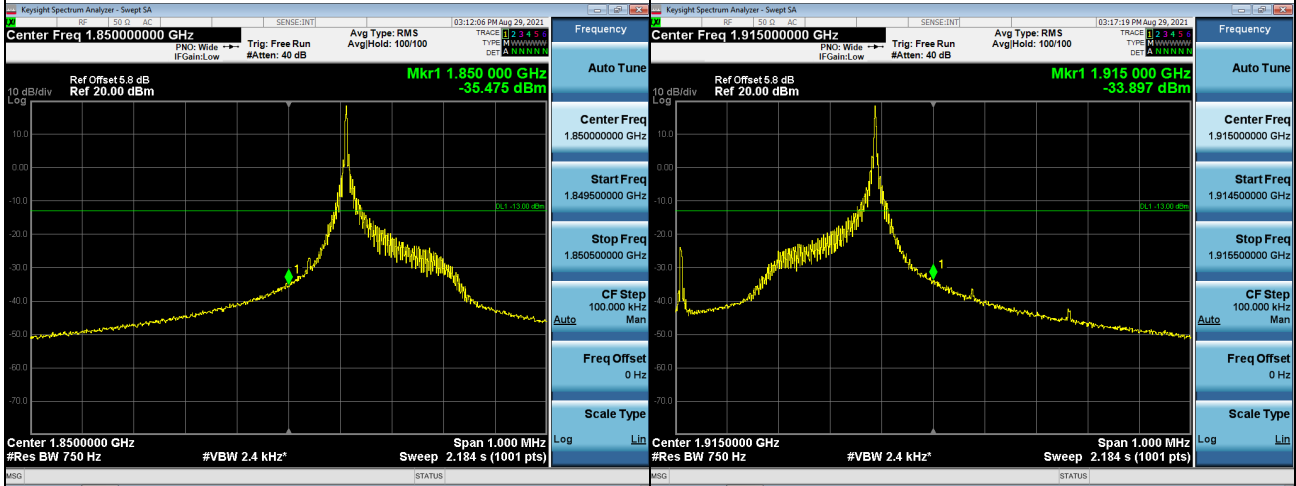

LTE Band 25_QPSK_15KHz Spectrum Plot

1RB#0

1RB#11

Channel

26041

Channel

26689

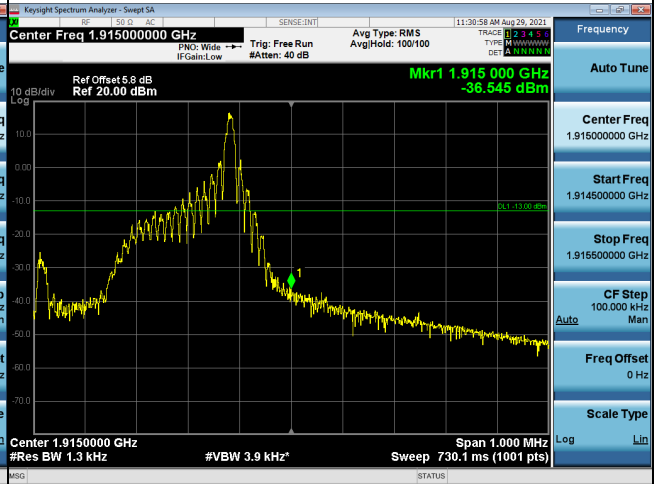
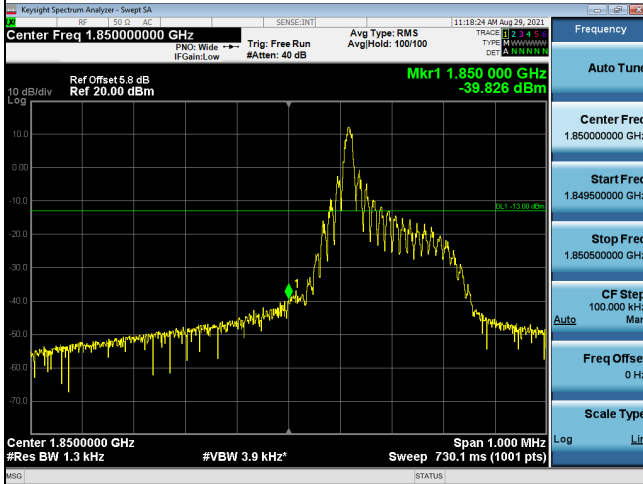

12RB#0

Channel

26041

Channel

26689

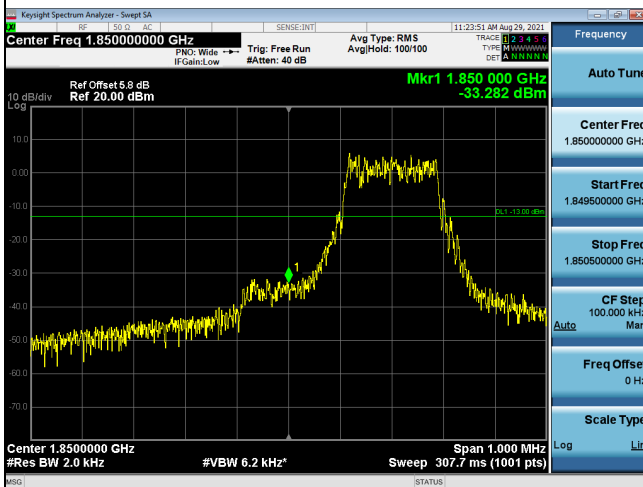

APPENDIX H - PEAK TO AVERAGE RATIO

LTE Band 2_3.75KHz Spectrum Plot



LTE Band 2_15KHz Spectrum Plot



LTE Band 25_3.75KHz Spectrum Plot

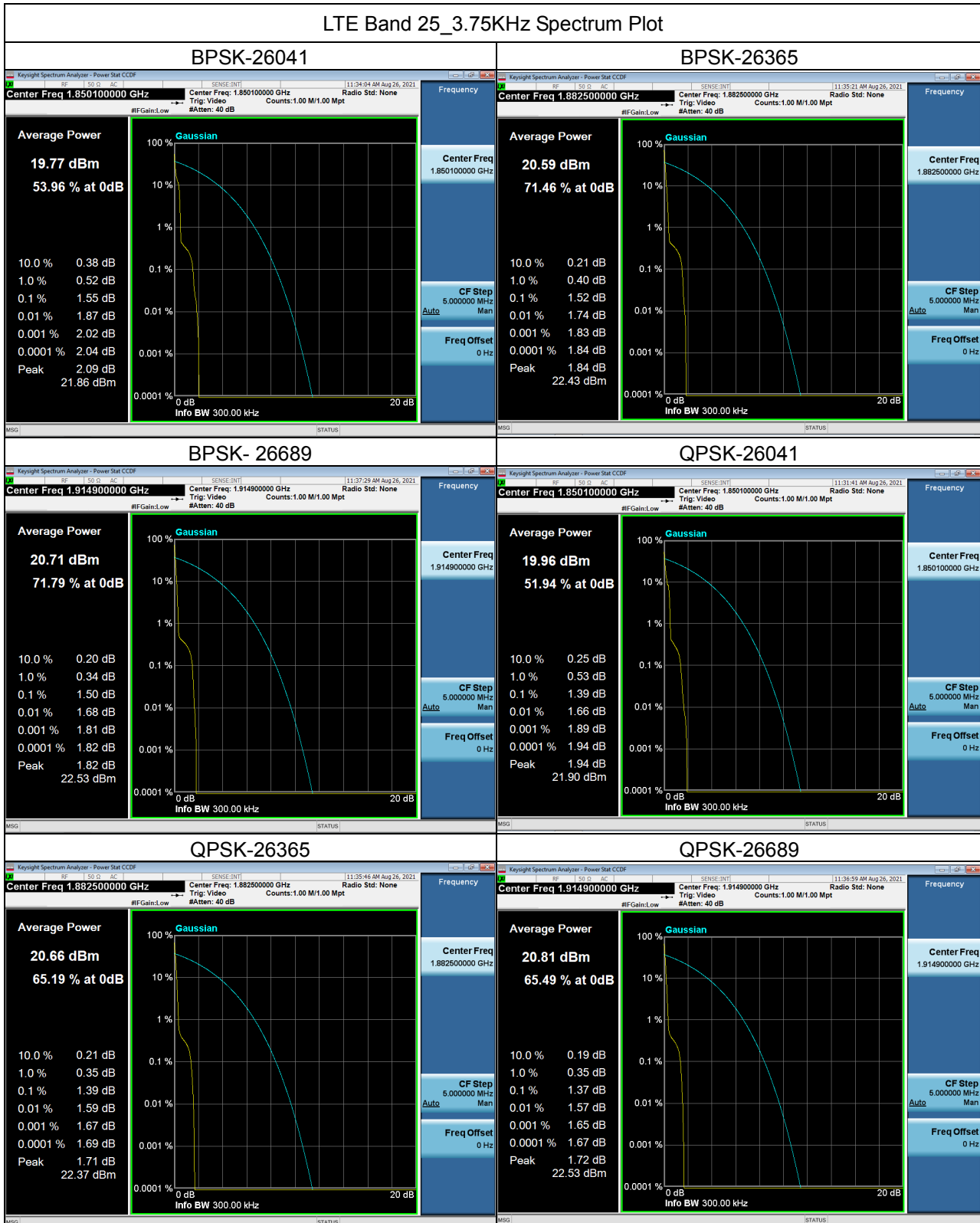

LTE Band 25_15KHz Spectrum Plot



APPENDIX I - FREQUENCY STABILITY

Test Mode	LTE Band 2_BPSK_CH18900_3.75KHz
-----------	---------------------------------

Temperature vs. Frequency Stability

Temperature(°C)	Frequency Error (Hz)	Frequency Error (ppm)	Limit(ppm)
-30	1.25	0.000664894	±2.5
-20	-8.53	-0.004537234	
-10	-9.65	-0.005132979	
0	6.19	0.003292553	
10	13.01	0.006920213	
20	-9.22	-0.004904255	
30	0.19	0.000101064	
40	-14.80	-0.00787234	
50	-9.89	-0.005260638	
Max. Deviation (ppm)	-14.8	-0.00787234	

Voltage vs. Frequency Stability

Voltage(Volts)	Frequency Error (Hz)	Frequency Error (ppm)	Limit(ppm)
3.8	-1.23	-0.000654255	±2.5
3.6	-5.76	-0.00306383	
2.0	-2.83	-0.001505319	
Max. Deviation (ppm)	-5.76	-0.00306383	

Test Mode	LTE Band 2_BPSK_CH18900_15KHz
-----------	-------------------------------

Temperature vs. Frequency Stability

Temperature(°C)	Frequency Error (Hz)	Frequency Error (ppm)	Limit(ppm)
-30	4.10	0.002180851	±2.5
-20	-8.62	-0.004585106	
-10	13.61	0.007239362	
0	-13.39	-0.00712234	
10	-10.44	-0.005553191	
20	-14.57	-0.00775	
30	-12.15	-0.006462766	
40	-7.30	-0.003882979	
50	7.57	0.004026596	
Max. Deviation (ppm)	-14.57	-0.00775	

Voltage vs. Frequency Stability

Voltage(Volts)	Frequency Error (Hz)	Frequency Error (ppm)	Limit(ppm)
3.8	10.65	0.005664894	±2.5
3.6	0.43	0.000228723	
2.0	9.61	0.005111702	
Max. Deviation (ppm)	10.65	0.005664894	

Test Mode	LTE Band 2_QPSK_CH18900_3.75KHz
-----------	---------------------------------

Temperature vs. Frequency Stability

Temperature(°C)	Frequency Error (Hz)	Frequency Error (ppm)	Limit(ppm)
-30	11.99	0.00637766	±2.5
-20	-8.26	-0.004393617	
-10	-9.94	-0.005287234	
0	4.24	0.002255319	
10	9.36	0.004978723	
20	-0.56	-0.000297872	
30	-14.19	-0.007547872	
40	9.24	0.004914894	
50	-13.40	-0.00712766	
Max. Deviation (ppm)	-14.19	-0.007547872	

Voltage vs. Frequency Stability

Voltage(Volts)	Frequency Error (Hz)	Frequency Error (ppm)	Limit(ppm)
3.8	12.28	0.006531915	±2.5
3.6	-13.95	-0.007420213	
2.0	10.23	0.005441489	
Max. Deviation (ppm)	-13.95	-0.007420213	

Test Mode	LTE Band 2_QPSK_CH18900_15KHz
-----------	-------------------------------

Temperature vs. Frequency Stability

Temperature(°C)	Frequency Error (Hz)	Frequency Error (ppm)	Limit(ppm)
-30	11.29	0.006005319	±2.5
-20	4.67	0.002484043	
-10	0.62	0.000329787	
0	7.01	0.003728723	
10	-5.02	-0.002670213	
20	-3.28	-0.001744681	
30	4.42	0.002351064	
40	4.03	0.002143617	
50	6.82	0.00362766	
Max. Deviation (ppm)	7.01	0.003728723	

Voltage vs. Frequency Stability

Voltage(Volts)	Frequency Error (Hz)	Frequency Error (ppm)	Limit(ppm)
3.8	-7.41	-0.003941489	±2.5
3.6	-7.95	-0.004228723	
2.0	-7.45	-0.003962766	
Max. Deviation (ppm)	-7.95	-0.004228723	

Test Mode	LTE Band 25_BPSK_CH26365_3.75KHz
-----------	----------------------------------

Temperature vs. Frequency Stability

Temperature(°C)	Frequency Error (Hz)	Frequency Error (ppm)	Limit(ppm)
-30	1.25	0.000664894	±2.5
-20	-8.53	-0.004537234	
-10	-9.65	-0.005132979	
0	6.19	0.003292553	
10	13.01	0.006920213	
20	-9.22	-0.004904255	
30	0.19	0.000101064	
40	-14.80	-0.00787234	
50	-9.89	-0.005260638	
Max. Deviation (ppm)	-14.8	-0.00787234	

Voltage vs. Frequency Stability

Voltage(Volts)	Frequency Error (Hz)	Frequency Error (ppm)	Limit(ppm)
3.8	-1.23	-0.000654255	±2.5
3.6	-5.76	-0.00306383	
2.0	-2.83	-0.001505319	
Max. Deviation (ppm)	-5.76	-0.00306383	

Test Mode	LTE Band 25_BPSK_CH26365_15KHz
-----------	--------------------------------

Temperature vs. Frequency Stability

Temperature(°C)	Frequency Error (Hz)	Frequency Error (ppm)	Limit(ppm)
-30	4.10	0.002180851	±2.5
-20	-8.62	-0.004585106	
-10	13.61	0.007239362	
0	-13.39	-0.00712234	
10	-10.44	-0.005553191	
20	-14.57	-0.00775	
30	-12.15	-0.006462766	
40	-7.30	-0.003882979	
50	7.57	0.004026596	
Max. Deviation (ppm)	-14.57	-0.00775	

Voltage vs. Frequency Stability

Voltage(Volts)	Frequency Error (Hz)	Frequency Error (ppm)	Limit(ppm)
3.8	10.65	0.005664894	±2.5
3.6	0.43	0.000228723	
2.0	9.61	0.005111702	
Max. Deviation (ppm)	10.65	0.005664894	

Test Mode	LTE Band 25_QPSK_CH26365_3.75KHz
-----------	----------------------------------

Temperature vs. Frequency Stability

Temperature(°C)	Frequency Error (Hz)	Frequency Error (ppm)	Limit(ppm)
-30	11.99	0.00637766	±2.5
-20	-8.26	-0.004393617	
-10	-9.94	-0.005287234	
0	4.24	0.002255319	
10	9.36	0.004978723	
20	-0.56	-0.000297872	
30	-14.19	-0.007547872	
40	9.24	0.004914894	
50	-13.40	-0.00712766	
Max. Deviation (ppm)	-14.19	-0.007547872	

Voltage vs. Frequency Stability

Voltage(Volts)	Frequency Error (Hz)	Frequency Error (ppm)	Limit(ppm)
3.8	12.28	0.006531915	±2.5
3.6	-13.95	-0.007420213	
2.0	10.23	0.005441489	
Max. Deviation (ppm)	-13.95	-0.007420213	

Test Mode	LTE Band 25_QPSK_CH26365_15KHz
-----------	--------------------------------

Temperature vs. Frequency Stability

Temperature(°C)	Frequency Error (Hz)	Frequency Error (ppm)	Limit(ppm)
-30	11.29	0.006005319	±2.5
-20	4.67	0.002484043	
-10	0.62	0.000329787	
0	7.01	0.003728723	
10	-5.02	-0.002670213	
20	-3.28	-0.001744681	
30	4.42	0.002351064	
40	4.03	0.002143617	
50	6.82	0.00362766	
Max. Deviation (ppm)	7.01	0.003728723	

Voltage vs. Frequency Stability

Voltage(Volts)	Frequency Error (Hz)	Frequency Error (ppm)	Limit(ppm)
3.8	-7.41	-0.003941489	±2.5
3.6	-7.95	-0.004228723	
2.0	-7.45	-0.003962766	
Max. Deviation (ppm)	-7.95	-0.004228723	

End of Test Report