



Certification Test Report

**FCC ID: HSW2832
IC: 4492A-2832**

**FCC Rule Part: 15.247
ISED Canada Radio Standards Specification: RSS-247**

Report Number: AT72126480-1C1

**Manufacturer: Murata Electronics North America
Model: MBN52832**

**Test Begin Date: April 11, 2017
Test End Date: April 19, 2017**

Report Issue Date: August 25, 2017



FOR THE SCOPE OF ACCREDITATION UNDER Certificate Number: AT-2021

This report must not be used by the client to claim product certification, approval, or endorsement by ANAB, NIST, or any agency of the Federal Government.

Prepared by:

**Ryan McGann
Senior Engineer
TÜV SÜD America Inc.**

Reviewed by:

**Thierry Jean-Charles
EMC Engineer
TÜV SÜD America Inc.**

This test report shall not be reproduced except in full. This report may be reproduced in part with prior written consent of TÜV SÜD America Inc. The results contained in this report are representative of the sample(s) submitted for evaluation.

This report contains 25 pages

TABLE OF CONTENTS

1	GENERAL	3
1.1	PURPOSE	3
1.2	PRODUCT DESCRIPTION	3
1.3	TEST METHODOLOGY AND CONSIDERATIONS	4
2	TEST FACILITIES	5
2.1	LOCATION	5
2.2	LABORATORY ACCREDITATIONS/RECOGNITIONS/CERTIFICATIONS	5
2.3	RADIATED EMISSIONS TEST SITE DESCRIPTION	6
2.3.1	<i>Semi-Anechoic Chamber Test Site</i>	6
2.3.2	<i>Open Area Tests Site (OATS)</i>	7
2.4	CONDUCTED EMISSIONS TEST SITE DESCRIPTION	8
3	APPLICABLE STANDARD REFERENCES	8
4	LIST OF TEST EQUIPMENT	9
5	SUPPORT EQUIPMENT	10
6	EQUIPMENT UNDER TEST SETUP BLOCK DIAGRAM	11
7	SUMMARY OF TESTS	12
7.1	ANTENNA REQUIREMENT – FCC: SECTION 15.203	12
7.2	POWER LINE CONDUCTED EMISSIONS – FCC: SECTION 15.207; ISED CANADA: RSS-GEN 8.8	12
7.2.1	<i>Measurement Procedure</i>	12
7.2.2	<i>Measurement Results</i>	12
7.3	6 DB / 99 % BANDWIDTH – FCC: SECTION 15.247(A)(2); ISED CANADA: RSS-247 5.2(A)	16
7.3.1	<i>Measurement Procedure</i>	16
7.3.2	<i>Measurement Results</i>	16
7.4	FUNDAMENTAL EMISSION OUTPUT POWER – FCC: SECTION 15.247(B)(3); ISED CANADA: RSS-247 5.4(D)	18
7.4.1	<i>Measurement Procedure</i>	18
7.4.2	<i>Measurement Results</i>	18
7.5	EMISSION LEVELS	19
7.5.1	<i>Emissions into Non-restricted Frequency Bands – FCC: Section 15.247(d); ISED Canada: RSS-247 5.5</i>	19
7.5.1.1	<i>Measurement Procedure</i>	19
7.5.1.2	<i>Measurement Results</i>	19
7.5.2	<i>Emissions into Restricted Frequency Bands – FCC: Section 15.205, 15.209; ISED Canada: RSS-Gen 8.9 / 8.10</i>	21
7.5.2.1	<i>Measurement Procedure</i>	21
7.5.2.2	<i>Duty Cycle Correction</i>	21
7.5.2.3	<i>Measurement Results</i>	21
7.5.2.4	<i>Sample Calculation</i>	23
7.6	MAXIMUM POWER SPECTRAL DENSITY IN THE FUNDAMENTAL EMISSION – FCC: SECTION 15.247(E); ISED CANADA: RSS-247 5.2(B)	24
7.6.1	<i>Measurement Procedure</i>	24
7.6.2	<i>Measurement Results</i>	24
8	ESTIMATION OF MEASUREMENT UNCERTAINTY	25
9	CONCLUSION	25

1 GENERAL

1.1 Purpose

The purpose of this report is to demonstrate compliance with Part 15 Subpart C of the FCC's Code of Federal Regulations and Innovation, Science, and Economic Development Canada's Radio Standards Specification RSS-247 Certification for modular approval.

1.2 Product Description

The MBN52832 is a Bluetooth Low Energy (BLE) module designed for IoT applications. The module consists of an nRF52832 SoC from Nordic Semiconductor. This SoC contains a 2.4 GHz BLE radio along with an integrated microprocessor to run the BLE software stack. Customers can load application software into the device that allows the module to do various tasks – measure a voltage, set an output bit, transmit data to another unit, etc. Basic radio operation (output power, channelization, etc.) is operated by the lower levels of the BLE stack and is not accessible to the module user.

Technical Information:

Detail	Description
Frequency Range	2402 - 2480 MHz
Number of Channels	40
Modulation Format	GFSK
Data Rates	1 MBPS
Operating Voltage	Coin Cell Battery: 3Vdc External Power Supply: 5Vdc Universal Serial Bus: 5Vdc
Antenna Type / Gain	Printed Trace Antenna: -2.5 dBi CUSHCRAFT S2406PL Patch Antenna: 6 dBi LCom HG2407RD-RSP Dipole Antenna: 7dBi

Manufacturer Information:

Murata Electronics North America
2200 Lake Park Drive
Smyrna, GA 30080

Test Sample Serial Number: Radiated Emissions: FCC Unit 2, FCC Conducted 1
Power Line Conducted Emissions: FCC Conducted 1
RF Conducted: FCC Conducted 1

Test Sample Condition: The test samples were provided in good working order with no visible defects.

1.3 Test Methodology and Considerations

The EUT is capable of being powered from a coin cell battery, commercially available wall-wart power supply, and the USB communication cable from a laptop. All modes of operation, including all data rates, were evaluated and the data presented in this report represents the worst case where applicable. The module was tested in a standalone condition on an evaluation board.

For radiated emissions, the EUT was evaluated in three orthogonal orientations. The worst-case orientation was Z-orientation. The EUT was evaluated with the coin cell battery, wall-wart power supply, and over USB from a representative laptop computer. The worst-case power mode was the wall-wart power supply. See test setup photos for more information. The EUT was evaluated with the highest gain antenna of each type. See the Theory of Operations for more information.

For AC power line conducted emissions, the EUT was evaluated with a commercially available wall-wart power supply and over USB from a laptop computer. The worst-case power mode was over USB from a laptop computer and was evaluated with the highest gain antenna of each type.

For RF Conducted Emissions, the EUT was evaluated using the external U.FL antenna connector with suitable attenuation. The coupling cable and external attenuation were considered for all RF conducted measurements.

Power setting during test: 0

2 TEST FACILITIES

2.1 Location

The radiated and conducted emissions test sites are located at the following address:

TÜV SÜD America, Inc.
5015 B.U. Bowman Drive
Buford, GA 30518
Phone: (770) 831-8048
Fax: (770) 831-8598

2.2 Laboratory Accreditations/Recognitions/Certifications

TÜV SÜD America, Inc. is accredited to ISO/IEC 17025 by the ANSI-ASQ National Accreditation Board/ANAB accreditation program, and has been issued certificate number AT-2021 in recognition of this accreditation. Unless otherwise specified, all tests methods described within this report are covered under the ISO/IEC 17025 scope of accreditation.

The Semi-Anechoic Chamber Test Site, Open Area Test Site (OATS) and Conducted Emissions Site have been fully described, submitted to, and accepted by the FCC, ISED Canada and the Japanese Voluntary Control Council for Interference by information technology equipment.

FCC Registration Number: 391271

ISED Canada Lab Code: IC 4175A

VCCI Member Number: 1831

- VCCI OATS Registration Number R-1526
- VCCI Conducted Emissions Site Registration Number: C-1608

2.3 Radiated Emissions Test Site Description

2.3.1 Semi-Anechoic Chamber Test Site

The Semi-Anechoic Chamber Test Site consists of a 20' x 30' x 18' shielded enclosure. The chamber is lined with Toyo Ferrite Grid Absorber, model number FFG-1000. The ferrite tile grid is 101 x 101 x 19mm thick and weighs approximately 550 grams. These tiles are mounted on steel panels and installed directly on the inner walls of the chamber.

The turntable is 150cm in diameter and is located 160cm from the back wall of the chamber. The chamber is grounded via 1 - 8' copper ground rod, installed at the center of the back wall, it is bound to the ground plane using 3/4" stainless steel braided cable.

The turntable is all steel, flush mounted table installed in an all steel frame. The table is remotely operated from inside the control room located 25' from the range. The turntable is electrically bonded to the surrounding ground plane via steel fingers installed on the edge of the turn table. The steel fingers make constant contact with the ground plane during operation.

Behind the turntable is a 3' x 6' x 4' deep shielded pit used for support equipment if necessary. The pit is equipped with 1 - 4" PVC chases from the turntable to the pit that allow for cabling to the EUT if necessary. The underside of the turntable can be accessed from the pit so cables can be supplied to the EUT from the pit.

A diagram of the Semi-Anechoic Chamber Test Site is shown in Figure 2.3-1 below:

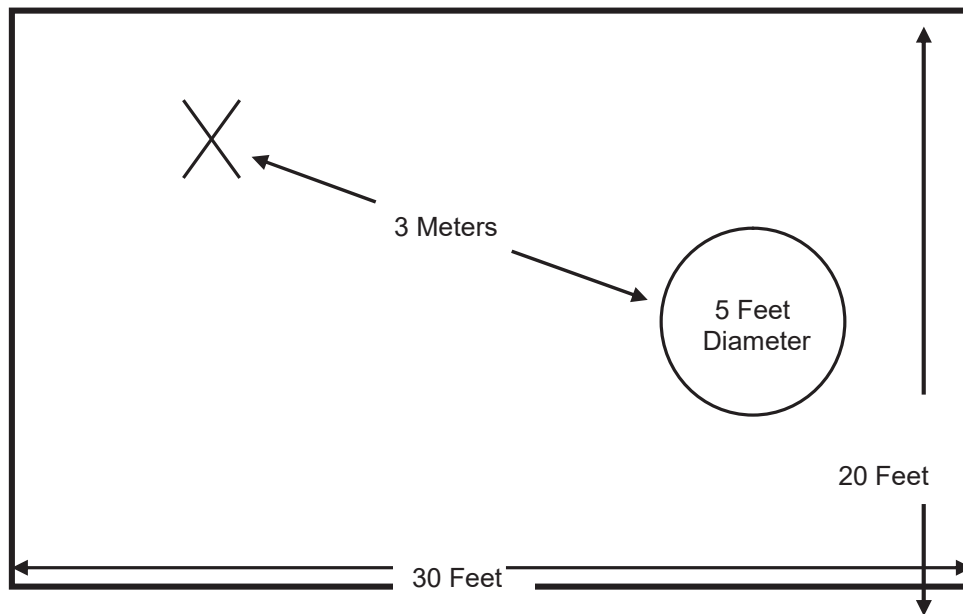

Figure 2.3-1: Semi-Anechoic Chamber Test Site

2.3.2 Open Area Tests Site (OATS)

The open area test site consists of a 40' x 66' concrete pad covered with a perforated electro-plated galvanized sheet metal. The perforations in the sheet metal are 1/8" holes that are staggered every 3/16". The individual sheets are placed to overlap each other by 1/4" and are riveted together to provide a continuous seam. Rivets are spaced every 3" in a 3 x 20 meter perimeter around the antenna mast and EUT area. Rivets in the remaining area are spaced as necessary to properly secure the ground plane and maintain the electrical continuity.

The entire ground plane extends 12' beyond the turntable edge and 16' beyond the antenna mast when set to a 10 meter measurement distance. The ground plane is grounded via 4 - 8' copper ground rods, each installed at a corner of the ground plane and bound to the ground plane using 3/4" stainless steel braided cable.

The turntable is an all aluminum 10' flush mounted table installed in an all aluminum frame. The table is remotely operated from inside the control room located 40' from the range. The turntable is electrically bonded to the surrounding ground plane via steel fingers installed on the edge of the turn table. The steel fingers make constant contact with the ground plane during operation.

Adjacent to the turntable is a 7' x 7' square and 4' deep concrete pit used for support equipment if necessary. The pit is equipped with 5 - 4" PVC chases from the pit to the control room that allow for cabling to the EUT if necessary. The underside of the turntable can be accessed from the pit so cables can be supplied to the EUT from the pit. The pit is covered with 2 sheets of 1/4" diamond style re-enforced steel sheets. The sheets are painted to match the perforated steel ground plane; however the underside edges have been masked off to maintain the electrical continuity of the ground plane. All reflecting objects are located outside of the ellipse defined in ANSI C63.10.

A diagram of the Open Area Test Site is shown in Figure 2.3-2 below:

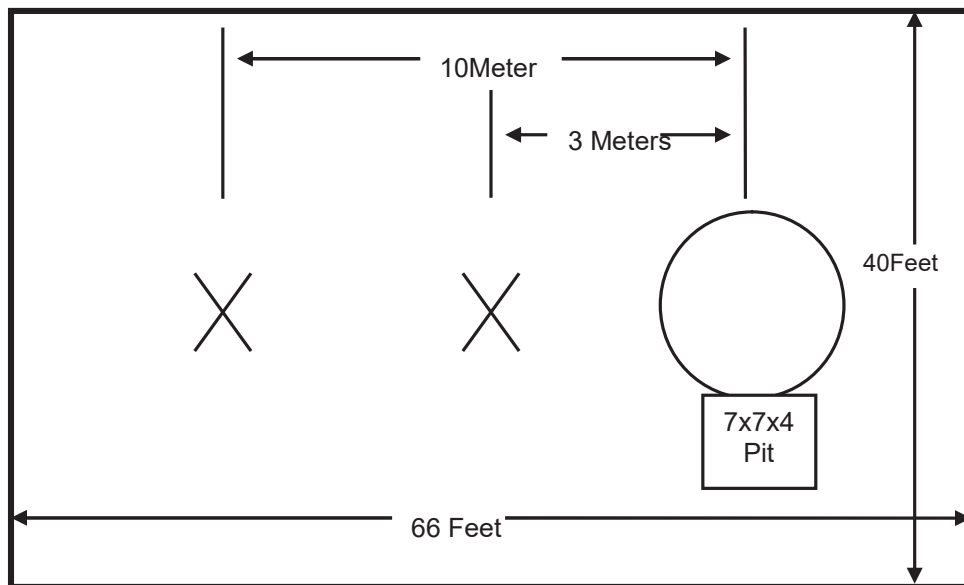

Figure 2.3-2: Open Area Test Site

2.4 Conducted Emissions Test Site Description

The AC mains conducted EMI site is located in the main EMC lab. It consists of an 8' x 8' solid aluminum horizontal ground reference plane (GRP) bonded every 3" to an 8' X 8' vertical ground plane.

The site is of sufficient size to test table top and floor standing equipment in accordance with ANSI C63.10.

A diagram of the room is shown below in figure 2.4-1:

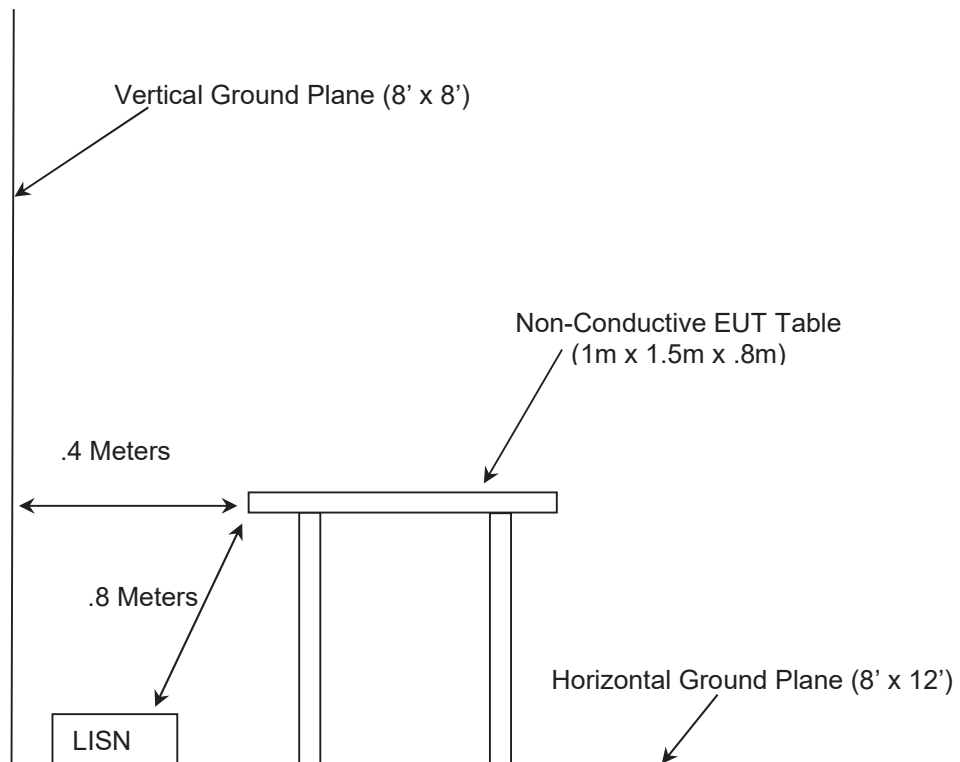

Figure 2.4-1: AC Mains Conducted EMI Site

3 APPLICABLE STANDARD REFERENCES

The following standards were used:

- ❖ ANSI C63.10-2013: American National Standard of Procedures for Compliance Testing of Unlicensed Wireless Devices.
- ❖ US Code of Federal Regulations (CFR): Title 47, Part 2, Subpart J: Equipment Authorization Procedures, 2017
- ❖ US Code of Federal Regulations (CFR): Title 47, Part 15, Subpart C: Radio Frequency Devices, Intentional Radiators, 2017
- ❖ FCC KDB 558074 D01 DTS Meas Guidance v04 - Guidance for Performing Compliance Measurements on Digital Transmission Systems (DTS) Operating Under §15.247, April 5, 2017
- ❖ ISED Canada Radio Standards Specification: RSS-247 – Digital Transmission Systems (DTSs), Frequency Hopping Systems (FHSs) and Licence-Exempt Local Area Network (LE-LAN) Devices, Issue 2, Feb 2017.
- ❖ ISED Canada Radio Standards Specification: RSS-GEN – General Requirements for Compliance of Radio Apparatus, Issue 4, Nov 2014.

4 LIST OF TEST EQUIPMENT

The calibration interval of test equipment is annually or the manufacturer's recommendations. Where the calibration interval deviates from the annual cycle based on the instrument manufacturer's recommendations, it shall be stated below.

Table 4-1: Test Equipment

AssetID	Manufacturer	Model #	Equipment Type	Serial #	Last Calibration Date	Calibration Due Date
30	Spectrum Technologies	DRH-0118	Antennas	970102	4/30/2015	4/30/2017
40	EMCO	3104	Antennas	3211	6/8/2016	6/8/2018
73	Agilent	8447D	Amplifiers	2727A05624	7/21/2016	7/21/2017
167	ACS	Chamber EMI Cable Set	Cable Set	167	9/30/2016	9/30/2017
267	Agilent	N1911A	Meters	MY45100129	8/24/2015	8/24/2017
268	Agilent	N1921A	Sensors	MY45240184	8/13/2015	8/13/2017
324	ACS	Belden	Cables	8214	3/21/2017	3/21/2018
334	Rohde&Schwarz	3160-09	Antennas	49404	11/4/2010	NCR
335	Suhner	SF-102A	Cables	882/2A	7/12/2016	7/12/2017
338	Hewlett Packard	8449B	Amplifiers	3008A01111	8/21/2015	8/21/2017
340	Aeroflex/Weinschel	AS-20	Attenuators	7136	7/12/2016	7/12/2017
345	Suhner Sucoflex	102A	Cables	1077/2A	7/12/2016	7/12/2017
412	Electro Metrics	LPA-25	Antennas	1241	8/8/2016	8/8/2018
422	Florida RF	SMS-200AW-72.0- SMR	Cables	805	10/27/2016	10/27/2017
432	Microwave Circuits	H3G020G4	Filters	264066	5/13/2016	5/13/2017
616	Florida RF Cables	SMRE-200W-12.0- SMRE	Cables	N/A	9/2/2016	9/2/2017
622	Rohde & Schwarz	FSV40	Analyzers	101338	7/15/2016	7/15/2018
676	Florida RF Labs	SMS-290AW- 480.0-SMS	Cables	MFR2Y194	11/4/2016	11/4/2017
812	PMM	9030	Receiver	121WW30401	2/6/2017	2/6/2018
3010	Rohde & Schwarz	ENV216	LISN	3010	7/11/2016	7/11/2017
RE135	Rohde & Schwarz	FSP30	Spectrum Analyzers	835618/031	10/31/2016	10/31/2017

NCR = No Calibration Required

NOTE: All test equipment was used only during active calibration cycles.

5 SUPPORT EQUIPMENT

Table 5-1: Support Equipment – Radiated Emissions

Item	Equipment Type	Manufacturer	Model/Part Number	Serial Number
1	Wall Wart Power Supply	Cnet Enterprise Corp.	AD1605C	N/A

Table 5-2: Cable Description – Radiated Emissions

Cable	Cable Type	Length	Shield	Termination
A	RF Cable	10 cm (Lcom Antenna) 45 cm (CUSHCRAFT Antenna)	Yes	EUT to Antenna
B	DC Power Cable	250 cm	No	EUT to Wall Wart Power Supply

Table 5-3: Support Equipment – Power Line Conducted Emissions

Item	Equipment Type	Manufacturer	Model/Part Number	Serial Number
1	Laptop	Dell	Latitude E5450	N/A
2	Laptop Power Brick	Dell	LA65NM130	N/A
3	Headphones	Micro Innovations	N/A	N/A

Table 5-4: Cable Description – Power Line Conducted Emissions

Cable	Cable Type	Length	Shield	Termination
A	RF Cable	10 cm (Lcom Antenna) 45 cm (CUSHCRAFT Antenna)	Yes	EUT to Antenna
B	USB Cable	200 cm	No	EUT to Laptop
C	DC Power Cable	200 cm	No	Laptop to Power Brick
D	AC Power Cable	150 cm	No	Power Brick to AC Mains
E	Stereo Cable	200 cm	No	Laptop to Headphones

6 EQUIPMENT UNDER TEST SETUP BLOCK DIAGRAM

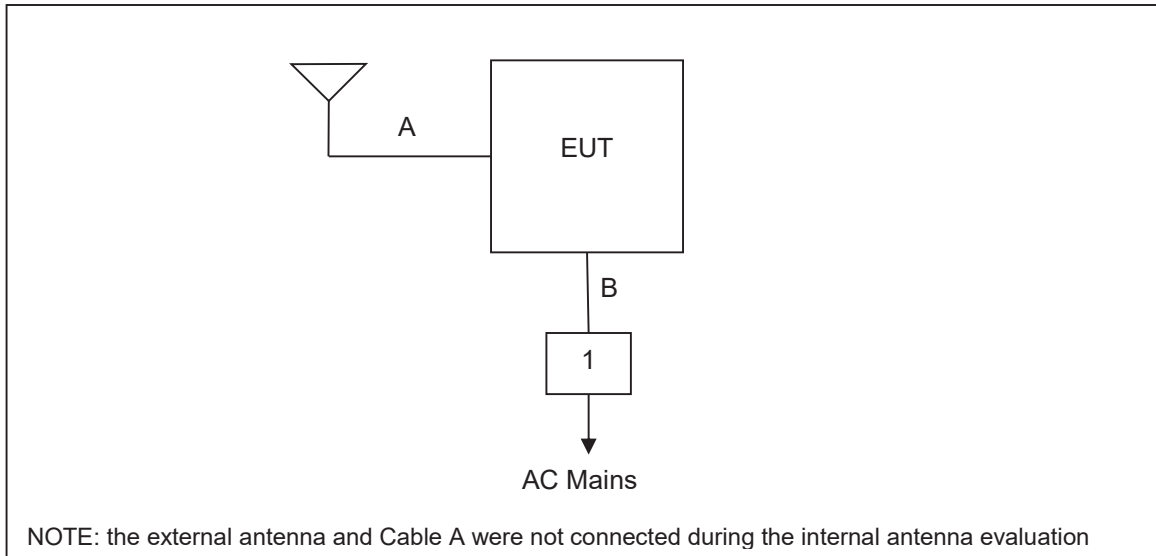

Figure 6-1: Test Setup Block Diagram – Radiated Emissions

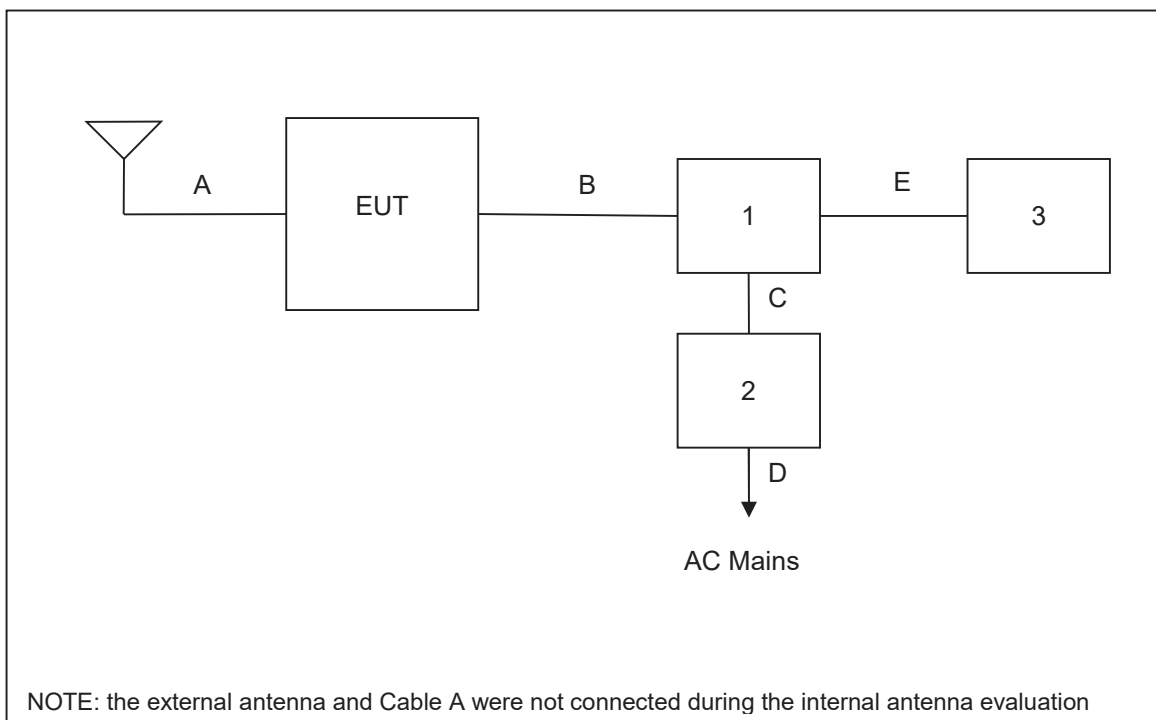

Figure 6-2: Test Setup Block Diagram – Power Line Conducted Emissions

7 SUMMARY OF TESTS

Along with the tabular data shown below, plots were taken of all signals deemed important enough to document.

7.1 Antenna Requirement – FCC: Section 15.203

The internal antenna is integrated to the PCB and cannot be removed without damage to the EUT, therefore satisfying the requirements of Section 15.203. The gain of the internal antenna is -2.5dBi. The external patch antenna and external dipole antenna interface with the EUT via a coax cable and U.FL connector. The gain of the patch antenna is 6 dBi. The gain of the dipole antenna is 7dBi.

7.2 Power Line Conducted Emissions – FCC: Section 15.207; ISED Canada: RSS-Gen 8.8

7.2.1 Measurement Procedure

Conducted emissions were performed from 150 kHz to 30 MHz with the spectrum analyzer's resolution bandwidth set to 9 kHz and the video bandwidth set to 30 kHz. The calculation for the conducted emissions is as follows:

Corrected Reading = Analyzer Reading + LISN Loss + Cable Loss
Margin = Applicable Limit - Corrected Reading

7.2.2 Measurement Results

Performed by: Ryan McGann

Table 7.2.2-1: Conducted EMI Results Line 1 – Internal Antenna

Frequency (MHz)	Corrected Reading		Limit		Margin		Correction (dB)
	Quasi-Peak (dBuV)	Average (dBuV)	Quasi-Peak (dBuV)	Average (dBuV)	Quasi-Peak (dB)	Average (dB)	
0.15	43.18	23.86	66	56	-22.82	-32.14	9.59
0.158	44.91	29.11	65.57	55.57	-20.66	-26.46	9.58
0.174	43.16	22.82	64.77	54.77	-21.61	-31.95	9.58
0.19	41.21	24.21	64.04	54.04	-22.83	-29.83	9.58
0.226	40.27	22.54	62.6	52.6	-22.33	-30.06	9.58
0.414	39.34	22.41	57.57	47.57	-18.23	-25.16	9.59
0.454	41.74	30.75	56.8	46.8	-15.06	-16.05	9.59
0.65	36.13	22.43	56	46	-19.87	-23.57	9.59
2.37	35.12	22.86	56	46	-20.88	-23.14	9.71
15.714	32.97	23.39	60	50	-27.03	-26.61	9.82

Table 7.2.2-2: Conducted EMI Results Line 2 – Internal Antenna

Frequency (MHz)	Corrected Reading		Limit		Margin		Correction (dB)
	Quasi-Peak (dBuV)	Average (dBuV)	Quasi-Peak (dBuV)	Average (dBuV)	Quasi-Peak (dB)	Average (dB)	
0.15	54.27	32.23	66	56	-11.73	-23.77	9.59
0.158	54.53	32.1	65.57	55.57	-11.04	-23.47	9.58
0.174	53.31	22.7	64.77	54.77	-11.46	-32.07	9.58
0.198	48.76	24.58	63.69	53.69	-14.93	-29.11	9.58
0.234	46.81	22.36	62.31	52.31	-15.5	-29.95	9.58
0.25	42.03	22.3	61.76	51.76	-19.73	-29.46	9.58
0.378	43.95	22.27	58.32	48.32	-14.37	-26.05	9.59
0.402	44.6	22.27	57.81	47.81	-13.21	-25.54	9.59
0.458	46.72	27.13	56.73	46.73	-10.01	-19.6	9.59
0.486	44.37	22.35	56.24	46.24	-11.87	-23.89	9.59

Table 7.2.2-3: Conducted EMI Results Line 1 – Patch Antenna

Frequency (MHz)	Corrected Reading		Limit		Margin		Correction (dB)
	Quasi-Peak (dBuV)	Average (dBuV)	Quasi-Peak (dBuV)	Average (dBuV)	Quasi-Peak (dB)	Average (dB)	
0.15	54.78	36.91	66	56	-11.22	-19.09	9.59
0.17	46.38	22.7	64.96	54.96	-18.58	-32.26	9.58
0.182	50.41	25.44	64.39	54.39	-13.98	-28.95	9.58
0.19	49.92	29.32	64.04	54.04	-14.12	-24.72	9.58
0.23	48.22	22.4	62.45	52.45	-14.23	-30.05	9.58
0.242	41.82	22.35	62.03	52.03	-20.21	-29.68	9.58
0.378	40.84	24.04	58.32	48.32	-17.48	-24.28	9.59
0.438	41.03	24.17	57.1	47.1	-16.07	-22.93	9.59
0.47	42.8	29.47	56.51	46.51	-13.71	-17.04	9.59
0.486	42.47	27.25	56.24	46.24	-13.77	-18.99	9.59

Table 7.2.2-4: Conducted EMI Results Line 2 – Patch Antenna

Frequency (MHz)	Corrected Reading		Limit		Margin		Correction (dB)
	Quasi-Peak (dBuV)	Average (dBuV)	Quasi-Peak (dBuV)	Average (dBuV)	Quasi-Peak (dB)	Average (dB)	
0.15	52.78	29.98	66	56	-13.22	-26.02	9.59
0.194	48.46	24.45	63.86	53.86	-15.4	-29.41	9.58
0.23	45.96	22.4	62.45	52.45	-16.49	-30.05	9.58
0.29	41.88	22.33	60.52	50.52	-18.64	-28.19	9.59
0.35	39.04	22.32	58.96	48.96	-19.92	-26.64	9.59
0.394	43.48	24.12	57.98	47.98	-14.5	-23.86	9.59
0.406	45.79	27.63	57.73	47.73	-11.94	-20.1	9.59
0.434	45.29	25.5	57.18	47.18	-11.89	-21.68	9.59
0.45	43.75	29.08	56.88	46.88	-13.13	-17.8	9.59
0.478	43.73	25.1	56.37	46.37	-12.64	-21.27	9.59

Table 7.2.2-5: Conducted EMI Results Line 1 – Dipole Antenna

Frequency (MHz)	Corrected Reading		Limit		Margin		Correction (dB)
	Quasi-Peak (dBuV)	Average (dBuV)	Quasi-Peak (dBuV)	Average (dBuV)	Quasi-Peak (dB)	Average (dB)	
0.15	55.39	38.46	66	56	-10.61	-17.54	9.59
0.154	49.69	28.91	65.78	55.78	-16.09	-26.87	9.58
0.162	47.34	27.89	65.36	55.36	-18.02	-27.47	9.58
0.198	48.73	28.42	63.69	53.69	-14.96	-25.27	9.58
0.23	46.76	22.98	62.45	52.45	-15.69	-29.47	9.58
0.298	41.45	22.36	60.3	50.3	-18.85	-27.94	9.58
0.374	42.75	23.39	58.41	48.41	-15.66	-25.02	9.59
0.39	44.63	27.01	58.06	48.06	-13.43	-21.05	9.59
0.422	44.15	26.26	57.41	47.41	-13.26	-21.15	9.59
0.442	43.39	24.02	57.02	47.02	-13.63	-23	9.59

Table 7.2.2-6: Conducted EMI Results Line 2 – Dipole Antenna

Frequency (MHz)	Corrected Reading		Limit		Margin		Correction (dB)
	Quasi-Peak (dBuV)	Average (dBuV)	Quasi-Peak (dBuV)	Average (dBuV)	Quasi-Peak (dB)	Average (dB)	
0.15	53.82	32.85	66	56	-12.18	-23.15	9.59
0.19	48.74	23.17	64.04	54.04	-15.3	-30.87	9.58
0.222	45.21	22.43	62.74	52.74	-17.53	-30.31	9.58
0.39	44.59	23.84	58.06	48.06	-13.47	-24.22	9.59
0.406	45.09	27.44	57.73	47.73	-12.64	-20.29	9.59
0.418	44.82	26.23	57.49	47.49	-12.67	-21.26	9.59
0.438	42.96	26.58	57.1	47.1	-14.14	-20.52	9.59
0.454	45.58	29.2	56.8	46.8	-11.22	-17.6	9.59
0.474	44.79	25.75	56.44	46.44	-11.65	-20.69	9.59
0.49	43.56	22.36	56.17	46.17	-12.61	-23.81	9.59

7.3 6 dB / 99 % Bandwidth – FCC: Section 15.247(a)(2); ISED Canada: RSS-247 5.2(a)

7.3.1 Measurement Procedure

The 6 dB bandwidth was measured in accordance with the FCC KDB 558074 D01 DTS Meas Guidance. The Resolution Bandwidth (RBW) of the spectrum analyzer was set to 100 kHz. The Video Bandwidth (VBW) was set to ≥ 3 times the RBW. The trace was set to max hold with a peak detector active. The n-dB down function of the spectrum analyzer was utilized to determine the 6 dB bandwidth of the emission.

The occupied bandwidth measurement function of the spectrum analyzer was used to measure the 99 % bandwidth. The span of the analyzer was set to capture all products of the modulation process, including the emission sidebands. The resolution bandwidth was set from 1 % to 5 % of the occupied bandwidth and the video bandwidth set to at least 3 times the resolution bandwidth. A peak detector was used.

7.3.2 Measurement Results

Performed by: Ryan McGann

Table 7.3.2-1: 6 dB / 99 % Bandwidth

Frequency [MHz]	6 dB Bandwidth [kHz]	99 % Bandwidth [kHz]
2402	718.57	1063.09
2440	721.23	1068.25
2480	719.98	1060.12

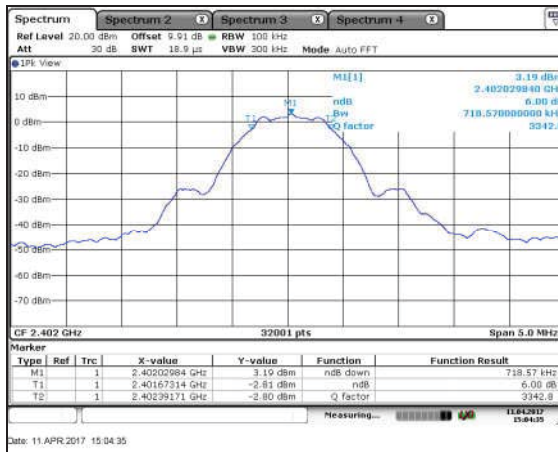

Figure 7.3.2-1: 6dB BW – LCH

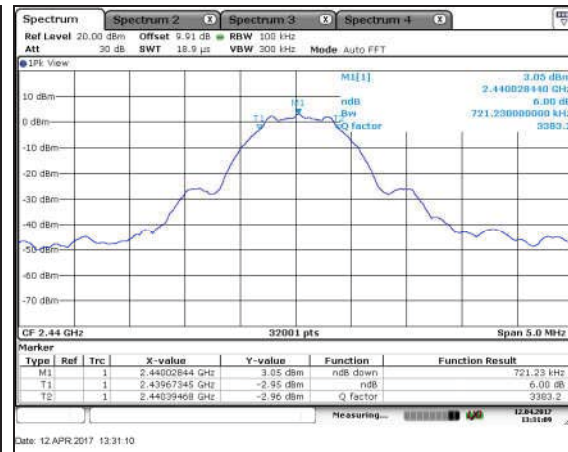

Figure 7.3.2-2: 6dB BW – MCH

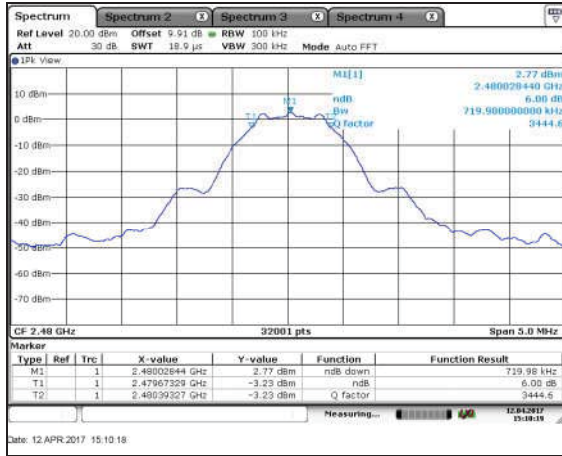

Figure 7.3.2-3: 6dB BW – HCH

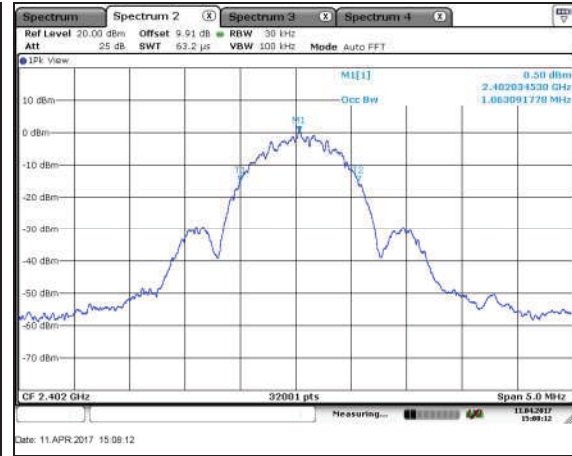

Figure 7.3.2-4: 99% OBW – LCH

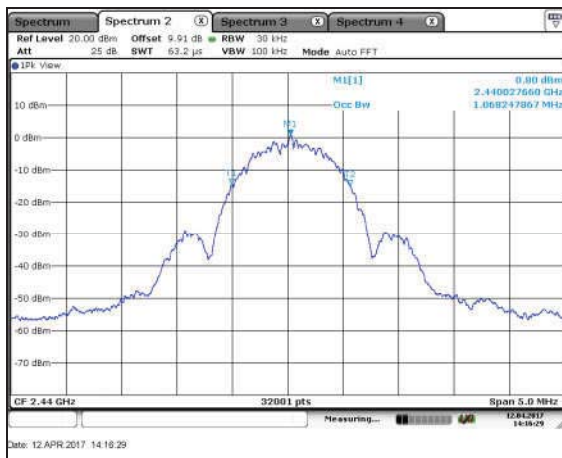

Figure 7.3.2-5: 99% OBW – MCH

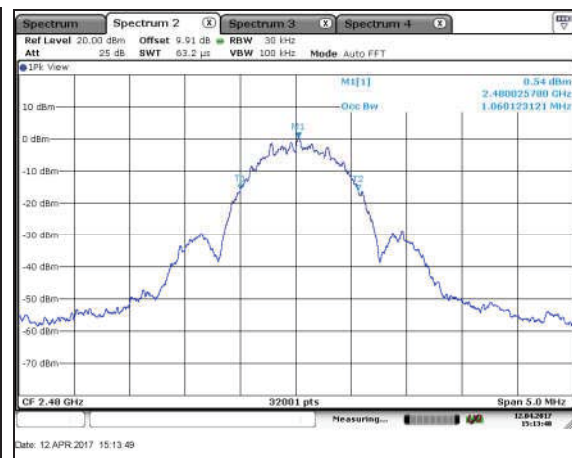

Figure 7.3.2-6: 99% OBW – HCH

7.4 Fundamental Emission Output Power – FCC: Section 15.247(b)(3); ISED Canada: RSS-247 5.4(d)**7.4.1 Measurement Procedure**

The maximum conducted output power was measured in accordance with FCC KDB 558074 D01 DTS Meas Guidance utilizing the PKPM procedure. The RF output of the equipment under test was directly connected to the input of the power meter applying suitable attenuation.

7.4.2 Measurement Results

Performed by: Ryan McGann

Table 7.4.2-1: Maximum Peak Conducted Output Power

Frequency [MHz]	Level [dBm]
2402	3.35
2440	3.13
2480	3.01

7.5 Emission Levels

7.5.1 Emissions into Non-restricted Frequency Bands – FCC: Section 15.247(d); ISED Canada: RSS-247 5.5

7.5.1.1 Measurement Procedure

The unwanted emissions into non-restricted bands were measured conducted in accordance with FCC KDB 558074 D01 DTS Meas Guidance. The RF output of the equipment under test was directly connected to the input of the spectrum analyzer applying suitable attenuation. The Resolution Bandwidth (RBW) of the spectrum analyzer was set to 100 kHz. The Video Bandwidth (VBW) was set to ≥ 300 kHz. Span was set to 1.5 times the DTS bandwidth. The trace was set to max hold with a peak detector active. The resulting spectrum analyzer peak level was used to determine the reference level with respect to the 20 dBc limit. The spectrum span was then adjusted for the measurement of spurious emissions from 30 MHz to 25 GHz, 10 times the highest fundamental frequency.

Band-edge compliance was determined using the conducted marker-delta method in which the radio frequency power that is produced by the EUT is at least 20 dB below that in the 100 kHz bandwidth within the band that contains the highest level of desired power.

7.5.1.2 Measurement Results

Performed by: Ryan McGann

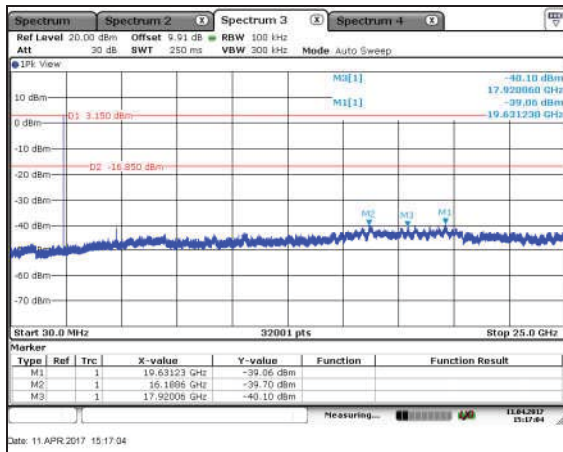

Figure 7.5.1.2-1: RF Conducted Emissions – LCH

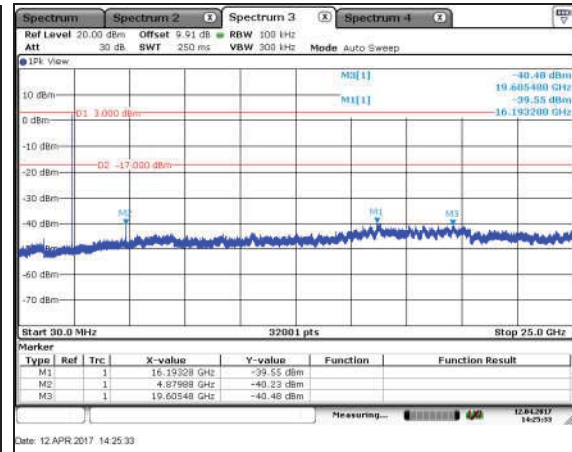

Figure 7.5.1.2-2: RF Conducted Emissions – MCH

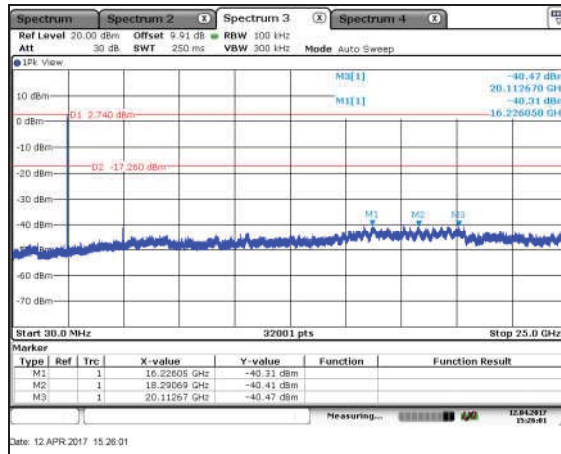

Figure 7.5.1.2-3: RF Conducted Emissions – HCH

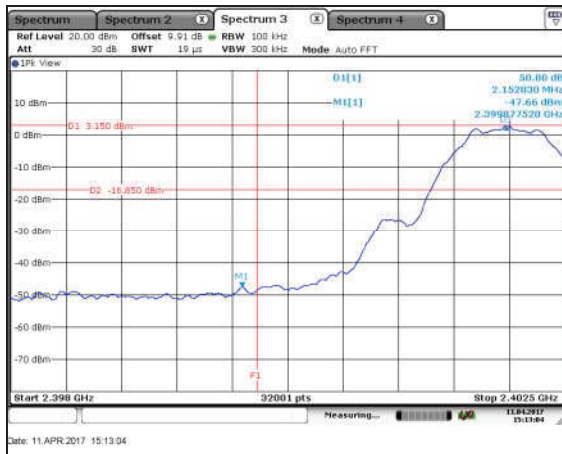

Figure 7.5.1.2-4: Lower Band-edge

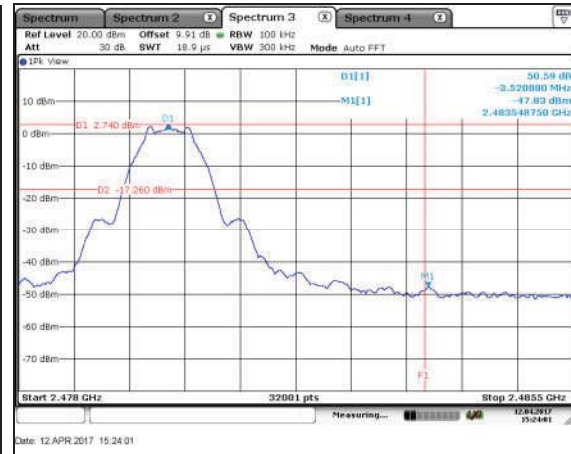

Figure 7.5.1.2-5: Upper Band-edge

7.5.2 Emissions into Restricted Frequency Bands – FCC: Section 15.205, 15.209; ISED Canada: RSS-Gen 8.9 / 8.10

7.5.2.1 Measurement Procedure

The unwanted emissions into restricted bands were measured radiated over the frequency range of 30 MHz to 25 GHz, 10 times the highest fundamental frequency.

The EUT was rotated through 360° and the receive antenna height was varied from 1 meter to 4 meters so that the maximum radiated emissions level would be detected. For frequencies below 1000 MHz, quasi-peak measurements were made using a resolution bandwidth RBW of 120 kHz and a video bandwidth VBW of 300 kHz. For frequencies above 1000 MHz, peak and average measurements were made with RBW and VBW of 1 MHz and 3 MHz respectively.

Each emission found to be in a restricted band as defined by section 15.205, including any emission at the operational band-edge, was compared to the radiated emission limits as defined in section 15.209.

7.5.2.2 Duty Cycle Correction

For average radiated measurements, using a 2.12% duty cycle, the measured level was reduced by a factor of 33.47 dB. The duty cycle correction factor is determined using the formula: $20\log(2.12/100) = -33.47$ dB. A detailed analysis of the duty cycle timing is provided in the Theory of Operation accompanying the application for certification.

7.5.2.3 Measurement Results

Performed by: Alton Smith, Arthur Sumner

Table 7.5.2.3-1: Radiated Spurious Emissions Tabulated Data – Internal Antenna

Frequency (MHz)	Level (dBuV)		Antenna Polarity (H/V)	Correction Factors (dB)	Corrected Level (dBuV/m)		Limit (dBuV/m)		Margin (dB)	
	pk	Qpk/Avg			pk	Qpk/Avg	pk	Qpk/Avg	pk	Qpk/Avg
Lowest Channel										
2390	36.45	35.86	H	-5.40	31.05	-3.01	74.0	54.0	42.9	57.0
2390	36.77	35.64	V	-5.40	31.37	-3.23	74.0	54.0	42.6	57.2
Middle Channel										
7320	39.96	37.30	H	7.74	47.70	11.57	74.0	54.0	26.3	42.4
7320	38.67	37.63	V	7.74	46.41	11.90	74.0	54.0	27.6	42.1
Highest Channel										
2483.5	63.92	60.60	H	-4.94	58.98	22.18	74.0	54.0	15.0	31.8
2483.5	55.76	51.17	V	-4.94	50.82	12.75	74.0	54.0	23.2	41.2
7440	51.15	41.60	H	7.84	58.99	15.96	74.0	54.0	15.0	38.0

Table 7.5.2.3-2: Radiated Spurious Emissions Tabulated Data – Patch Antenna

Frequency (MHz)	Level (dBuV)		Antenna Polarity (H/V)	Correction Factors (dB)	Corrected Level (dBuV/m)		Limit (dBuV/m)		Margin (dB)	
	pk	Qpk/Avg			pk	Qpk/Avg	pk	Qpk/Avg	pk	Qpk/Avg
Lowest Channel										
2390	38.55	37.34	H	-5.40	33.15	-1.53	74.0	54.0	40.8	55.5
2390	40.80	39.27	V	-5.40	35.40	0.40	74.0	54.0	38.6	53.6
4804	51.16	49.93	H	1.80	52.96	18.26	74.0	54.0	21.0	35.7
4804	48.45	47.37	V	1.80	50.25	15.70	74.0	54.0	23.7	38.3
Middle Channel										
4880	48.89	47.26	H	2.04	50.93	15.83	74.0	54.0	23.1	38.2
4880	45.76	44.61	V	2.04	47.80	13.18	74.0	54.0	26.2	40.8
7320	44.26	41.81	H	7.74	52.00	16.08	74.0	54.0	22.0	37.9
Highest Channel										
2483.5	54.91	54.00	H	-4.94	49.97	15.58	74.0	54.0	24.0	38.4
2483.5	66.32	65.19	V	-4.94	61.38	26.77	74.0	54.0	12.6	27.2
4960	50.42	49.25	H	2.29	52.71	18.07	74.0	54.0	21.3	35.9
4960	47.30	46.18	V	2.29	49.59	15.00	74.0	54.0	24.4	39.0

Table 7.5.2.2-3: Radiated Spurious Emissions Tabulated Data – Dipole Antenna

Frequency (MHz)	Level (dBuV)		Antenna Polarity (H/V)	Correction Factors (dB)	Corrected Level (dBuV/m)		Limit (dBuV/m)		Margin (dB)	
	pk	Qpk/Avg			pk	Qpk/Avg	pk	Qpk/Avg	pk	Qpk/Avg
Lowest Channel										
2390	38.69	37.11	H	-5.40	33.29	-1.76	74.0	54.0	40.7	55.8
2390	38.39	37.20	V	-5.40	32.99	-1.67	74.0	54.0	41.0	55.7
4804	46.00	45.04	H	1.80	47.80	13.37	74.0	54.0	26.2	40.6
4804	52.68	51.96	V	1.80	54.48	20.29	74.0	54.0	19.5	33.7
Middle Channel										
4880	46.75	45.70	H	2.04	48.79	14.27	74.0	54.0	25.2	39.7
4880	55.05	54.16	V	2.04	57.09	22.73	74.0	54.0	16.9	31.3
Highest Channel										
2483.5	54.55	53.10	H	-4.94	49.61	14.68	74.0	54.0	24.4	39.3
2483.5	60.43	58.76	V	-4.94	55.49	20.34	74.0	54.0	18.5	33.7
4960	44.79	43.35	H	2.29	47.08	12.17	74.0	54.0	26.9	41.8
4960	51.88	50.79	V	2.29	54.17	19.61	74.0	54.0	19.8	34.4
7440	43.20	41.95	H	7.84	51.04	16.31	74.0	54.0	23.0	37.7

7.5.2.4 Sample Calculation:

$$R_C = R_U + CF_T$$

Where:

CF_T	=	Total Correction Factor (AF+CA+AG)-DC (Average Measurements Only)
R_U	=	Uncorrected Reading
R_C	=	Corrected Level
AF	=	Antenna Factor
CA	=	Cable Attenuation
AG	=	Amplifier Gain
DC	=	Duty Cycle Correction Factor

Example Calculation: Peak – Internal AntennaCorrected Level: $36.45 - 5.40 = 31.05\text{dBuV/m}$ Margin: $74\text{dBuV/m} - 31.05\text{dBuV/m} = 42.9\text{dB}$ **Example Calculation: Average – Internal Antenna**Corrected Level: $35.86 - 5.40 - 33.47 = -3.01\text{dBuV}$ Margin: $54\text{dBuV} - -3.01\text{dBuV} = 57.0\text{dB}$

7.6 Maximum Power Spectral Density in the Fundamental Emission – FCC: Section 15.247(e); ISED Canada: RSS-247 5.2(b)

7.6.1 Measurement Procedure

The power spectral density was measured in accordance with the FCC KDB 558074 D01 DTS Meas Guidance utilizing the PKPSD method. The RF output of the equipment under test was directly connected to the input of the spectrum analyzer applying suitable attenuation. The Resolution Bandwidth (RBW) of the spectrum analyzer was set to 3 kHz. The Video Bandwidth (VBW) was set to 10 kHz. Span was set to 1.5 times the DTS Bandwidth. The trace was set to max peak with a peak detector active.

7.6.2 Measurement Results

Performed by: Ryan McGann

Table 7.6.2-1: Power Spectral Density

Frequency [MHz]	PSD Level [dBm]
2402	-10.14
2440	-9.79
2480	-10.44

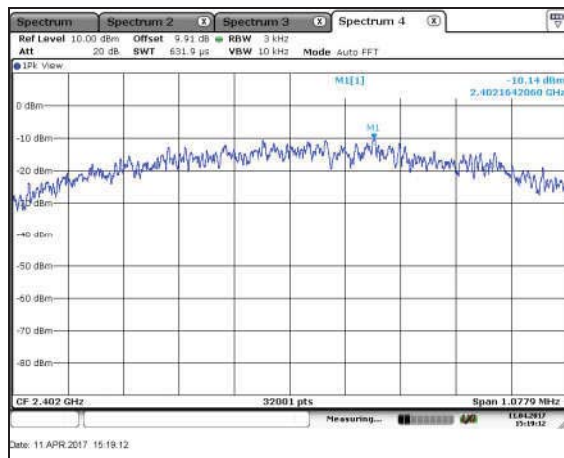

Figure 7.6.2-1: PSD – LCH

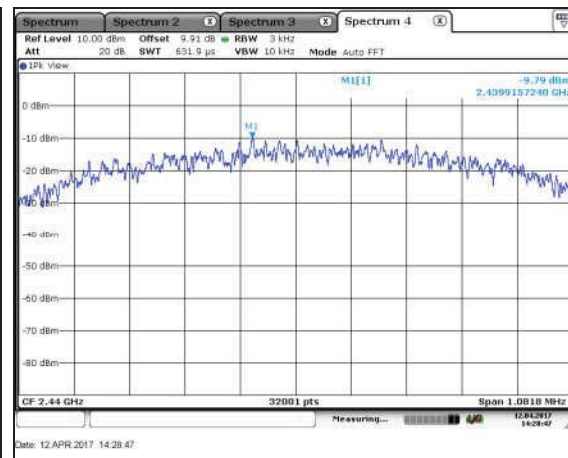

Figure 7.6.2-2: PSD – MCH

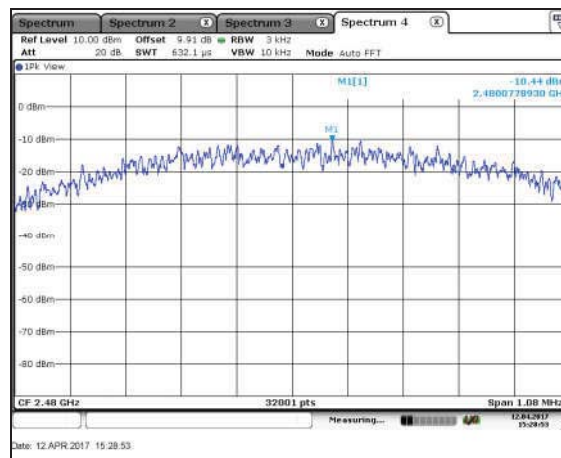

Figure 7.6.2-3: PSD – HCH

8 ESTIMATION OF MEASUREMENT UNCERTAINTY

The expanded laboratory measurement uncertainty figures (U_{Lab}) provided below correspond to an expansion factor (coverage factor) $k = 1.96$ which provide confidence levels of 95%.

Table 8-1: Estimation of Measurement Uncertainty

Parameter	U_{lab}
Occupied Channel Bandwidth	$\pm 0.009 \%$
RF Conducted Output Power	$\pm 0.349 \text{ dB}$
Power Spectral Density	$\pm 0.372 \text{ dB}$
Antenna Port Conducted Emissions	$\pm 1.264 \text{ dB}$
Radiated Emissions $\leq 1 \text{ GHz}$	$\pm 5.814 \text{ dB}$
Radiated Emissions $> 1 \text{ GHz}$	$\pm 4.318 \text{ dB}$
Temperature	$\pm 0.860 \text{ }^\circ\text{C}$
Radio Frequency	$\pm 2.832 \times 10^{-8}$
AC Power Line Conducted Emissions	$\pm 3.360 \text{ dB}$

9 CONCLUSION

In the opinion of TÜV SÜD America, Inc. the MBN52832, manufactured by Murata Electronics North America meets the requirements of FCC Part 15 subpart C and Innovation, Science, and Economic Development Canada's Radio Standards Specification RSS-247 for the tests documented in this test report.

END REPORT