



RF TEST REPORT

Report No.: SET2016-06124

Product: GPS Tracker

FCC ID: 2AH3LSVR2

Model No.: SVR-2

Applicant: ITrax, Inc.

Address: 2201 Francisco Drive Suite 140-257 El Dorado Hills, CA 95762

Dates of Testing: 04/12/2016 — 04/21/2016

Issued by: CCIC-SET

Lab Location: Electronic Testing Building, Shahe Road, Xili, Nanshan District,
Shenzhen, 518055, P. R. China

Tel: 86 755 26627338 **Fax:** 86 755 26627238

This test report consists of 47 pages in total. It may be duplicated completely for legal use with the approval of the applicant. It should not be reproduced except in full, without the written approval of our laboratory. The client should not use it to claim product endorsement by CCIC-SET. The test results in the report only apply to the tested sample. The test report shall be invalid without all the signatures of testing engineers, reviewer and approver. Any objections must be raised to CCIC-SET within 15 days since the date when the report is received. It will not be taken into consideration beyond this limit.



Test Report

Product.....: GPS Tracker

Brand Name.....: ITRAX

Trade Name.....: ITRAX

Applicant.....: ITrax, Inc.

Applicant Address.....: 2201 Francisco Drive Suite 140-257 El Dorado Hills, CA 95762

Manufacturer.....: SHENZHEN EELINK COMMUNICATION TECHNOLOGY CO., LTD.

Manufacturer Address.....: 3 Floor ,Yu yang mansion, 2nd Road of Langshan, Science and Technology Park, Nanshan District ,ShenZhen ,CHINA

Test Standards.....: 47 CFR FCC Part 2: Frequency Allocations and Radio Treaty Matters; General Rules and Regulations
47 CFR FCC Part 22(H): Cellular Radiotelephone Service
47 CFR FCC Part 24(E): Personal Communications Services

Test Result.....: PASS

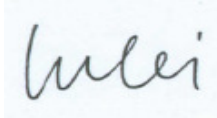
Tested by.....:  2016.04.21

Lu Lei, Test Engineer

Reviewed by.....:  2016.04.21

Zhu Qi, Senior EGINEER

Approved by.....:  2016.04.21

Wu Li'an, Manager



Table of Contents

- 1. GENERAL INFORMATION4
- 1.1 EUT Description4
- 1.2 Maximum ERP/EIRP Power, Frequency Tolerance, and Emission Designator5
- 1.3 Test Standards and Results6
- 1.4 Test Configuration of Equipment under Test.....7
- 1.5 Measurement Results Explanation Example8
- 1.6 Facilities and Accreditations8
- 2. 47 CFR PART 2, PART 22H & 24E REQUIREMENTS9
- 2.1 Conducted RF Output Power9
- 2.2 Peak to Average Ratio 11
- 2.3 99% Occupied Bandwidth and 26dB Bandwidth Measurement15
- 2.4 Frequency Stability23
- 2.5 Conducted Out of Band Emissions26
- 2.6 Band Edge34
- 2.7 Transmitter Radiated Power (EIRP/ERP)38
- 2.8 Radiated Spurious Emissions41
- 3. LIST OF MEASURING EQUIPMENT46
- 4. UNCERTAINTY OF EVALUATION47

Change History		
Issue	Date	Reason for change
1.0	2016.04.21	First edition



1. GENERAL INFORMATION

1.1 EUT Description

EUT Type	GPS Tracker
Hardware Version	GPT09_V13
Software Version	M6100_V1.9.8
EUT supports Radios application	GPRS
Multi Slot Class	GPRS: Multi slot Class12
Frequency Range	GPRS 850MHz: Tx: 824.2 - 848.8MHz (at intervals of 200kHz); Rx: 869.2 - 893.8MHz (at intervals of 200kHz) GPRS 1900MHz: Tx: 1850.2 - 1909.8MHz (at intervals of 200kHz); Rx: 1930.2 - 1989.8MHz (at intervals of 200kHz)
Maximum Output Power to Antenna	GPRS 850: 32.21dBm GPRS 1900: 28.98dBm
Type of Modulation	GPRS:GMSK
Antenna Type	PIFA Antenna
Antenna Gain	-1dBi



1.2 Maximum ERP/EIRP Power, Frequency Tolerance, and Emission Designator

System	Type of Modulation	Emission Designator	Frequency Tolerance (ppm)	Maximum ERP/EIRP(W)
GPRS 850	GMSK	246KGXW	0.03	1.358
GPRS 1900	GMSK	248KGXW	0.03	0.649



1.3 Test Standards and Results

1. 47 CFR Part 2, 22(H), 24(E)
2. ANSI / TIA / EIA-603-D-2010
3. FCC KDB 971168 D01 Power Meas. License Digital Systems v02r02

Remark:

1. All test items were verified and recorded according to the standards and without any deviation during the test.
2. This EUT has also been tested and complied with the requirements of FCC Part 15, Subpart B, recorded in a separate test report.

Test detailed items/section required by FCC rules and results are as below:

No.	Section	Description	Limit	Result
	FCC			
1	2.1046	Conducted Output Power	Reporting Only	PASS
2	24.232(d)	Peak to Average Ratio	< 13dBm	PASS
3	2.1049 22.917(b) 24.238(b)	Occupied Bandwidth	Reporting Only	PASS
4	2.1055 22.355 24.235	Frequency Stability	$\leq \pm 2.5\text{ppm}$	PASS
5	2.1051 22.917 24.238	Conducted Out of Band Emissions	$< 43+10\log_{10}$ (P[Watts])	PASS
6	2.1051 22.917 24.238	Band Edge	$< 43+10\log_{10}$ (P[Watts])	PASS
7	22.913	Effective Radiated Power	< 7Watts	PASS
	24.232	Equivalent Isotropic Radiated Power	< 2Watts	PASS
8	2.1053 22.917 24.238	Radiated Spurious Emissions	$< 43+10\log_{10}$ (P[Watts])	PASS



1.4 Test Configuration of Equipment under Test

Antenna port conducted and radiated test items were performed according to KDB 971168 D01 Power Meas. License Digital Systems v02r02 with maximum output power.

Radiated measurements were performed with rotating EUT in different three orthogonal test planes to find the maximum emission.

Radiated emissions were investigated as following frequency range:

1. 30 MHz to 9000 MHz for GPRS 850.
2. 30 MHz to 20000 MHz for GPRS 1900.

All modes and data rates and positions were investigated.

Test modes are chosen to be reported as the worst case configuration below:

Test Modes		
Band	Radiated TCs	Conducted TCs
GPRS 850	GPRS Link	GRPS Link
GPRS 1900	GPRS Link	GRPS Link

Note: The maximum power levels are chosen to test as the worst case configuration as follows:
GPRS mode for GMSK modulation, only these modes were used for all tests.



1.5 Measurement Results Explanation Example

For all conducted test items:

The offset level is set in the spectrum analyzer to compensate the RF cable loss and attenuator factor between EUT conducted output port and spectrum analyzer. With the offset compensation, the spectrum analyzer reading level is exactly the EUT RF output level.

The spectrum analyzer offset is derived from RF cable loss and attenuator factor.

Offset = RF cable loss + attenuator factor.

Following shows an offset computation example with cable loss 7dB and 10dB attenuator.

Example:

$$\begin{aligned}\text{Offset (dB)} &= \text{RF cable loss(dB)} + \text{attenuator factor(dB)} \\ &= 7 + 10 = 17 \text{ (dB)}\end{aligned}$$

1.6 Facilities and Accreditations

1.6.1 Test Facilities

CNAS-Lab Code: L1659

CCIC Southern Electronic Product Testing (Shenzhen) Co., Ltd. CCIC is a third party testing organization accredited by China National Accreditation Service for Conformity Assessment (CNAS) according to ISO/IEC 17025. The accreditation certificate number is L1659. A 12.8*6.8*6.4 (m) fully anechoic chamber was used for the radiated spurious emissions test.

FCC-Registration No.: 406086

CCIC Southern Electronic Product Testing (Shenzhen) Co., Ltd. EMC Laboratory has been registered and fully described in a report filed with the FCC (Federal Communications Commission). The acceptance letter from the FCC is maintained in our files. Registration 406086, October 28, 2017.

IC-Registration No.: 11185A-1

CCIC Southern Electronic Product Testing (Shenzhen) Co., Ltd. EMC Laboratory has been registered by Certification and Engineering Bureau of Industry Canada for the performance of radiated measurements with Registration No. 11185A-1 on July. 15, 2013, valid time is until July. 15, 2016.

1.6.2 Test Environment Conditions

During the measurement, the environmental conditions were within the listed ranges:

Temperature (°C):	15°C - 35°C
Relative Humidity (%):	30% -60%
Atmospheric Pressure (kPa):	86KPa-106KPa

2. 47 CFR PART 2, PART 22H & 24E REQUIREMENTS

2.1 Conducted RF Output Power

2.1.1 Definition

A system simulator was used to establish communication with the EUT. Its parameters were set to enforce EUT transmitting at the maximum power. The measured power in the radio frequency on the transmitter output terminals shall be reported.

2.1.2 Measuring Instruments

The measuring equipment is listed in the section 3 of this test report.

2.1.3 Test Procedures

1. The transmitter output port was connected to the system simulator.
2. Set EUT at maximum power through system simulator.
3. Select lowest, middle, and highest channels for each band and different modulation.
4. Measure and record the power level from the system simulator.

2.1.4 Test Setup

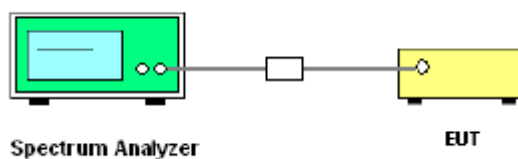



2.1.5 Test Results of Conducted Output Power

Conducted Power (Unit: dBm)						
Band	GPRS 850			GPRS 1900		
Channel	128	188	251	512	661	810
Frequency	824.2	836.2	848.8	1850.2	1880.0	1909.8
GPRS 8	32.09	32.16	32.21	28.91	28.98	28.94
GPRS 10	31.51	31.43	31.46	28.66	28.59	28.67
GPRS 12	28.89	28.81	28.79	25.68	25.61	25.71

2.2 Peak to Average Ratio

2.2.1 Definition

Power Complementary Cumulative Distribution Function (CCDF) curves provide a means for characterizing the power peaks of a digitally modulated signal on a statistical basis. A CCDF curve depicts the probability of the peak signal amplitude exceeding the average power level. Most contemporary measurement instrumentation include the capability to produce CCDF curves for an input signal provided that the instrument's resolution bandwidth can be set wide enough to accommodate the entire input signal bandwidth. In measuring transmissions in this band using an average power technique, the peak-to-average ratio (PAR) of the transmission may not exceed 13 dB.

2.2.2 Measuring Instruments

The measuring equipment is listed in the section 3 of this test report.

2.2.3 Test Procedures

1. The testing follows FCC KDB 971168 D01v02r02 Section 5.7.1.
2. The EUT was connected to the spectrum analyzer and system simulator via a power divider.
3. For GSM/EGPRS operating modes:
 - a. Set EUT in maximum power output.
 - b. Set the RBW = 1MHz, VBW = 3MHz, Peak detector on spectrum analyzer for first trace.
 - c. Set the RBW = 1MHz, VBW = 3MHz, RMS detector on spectrum analyzer for second trace.
 - d. The wanted burst signal is triggered by spectrum analyzer, and measured respectively the peak level and Mean level without burst-off time, after system simulator has synchronized with the spectrum analyzer.
4. For UMTS operating modes:
 - a. Set the CCDF (Complementary Cumulative Distribution Function) option on the spectrum analyzer.
 - b. The highest RF powers were measured and recorded the maximum PAPR level associated with a probability of 0.1 %.
5. Record the deviation as Peak to Average Ratio.

2.2.4 Test Setup

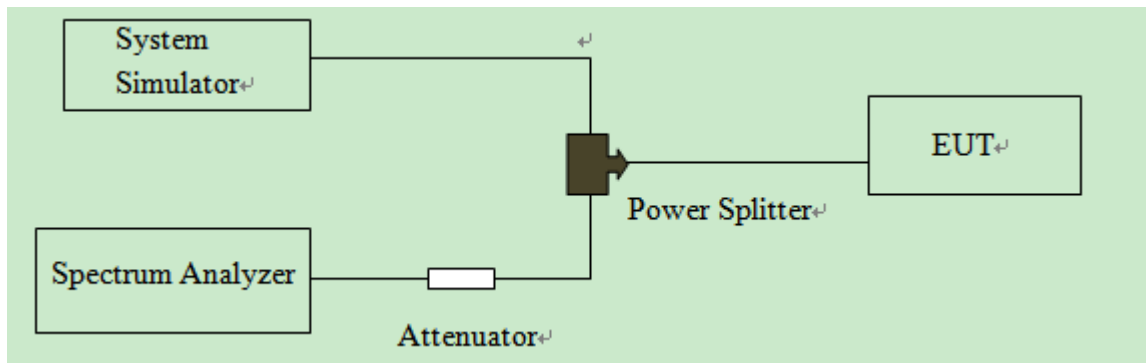

2.2.5 Test Results of Peak-to-Average Ratio

Band	Channel	Frequency (MHz)	Peak to Average ratio		Limit dB	Verdict
			dB	Refer to Plot		
GPRS 1900MHz	512	1850.2	0.23	Plot A1 to A3	13	PASS
	661	1880.0	0.57			PASS
	810	1909.8	0.87			PASS

2.2.6 Test Results (Plots) of Peak-to-Average Ratio

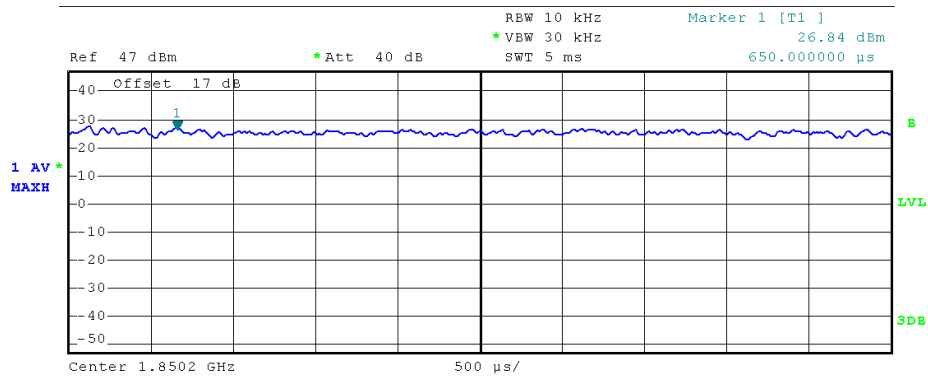
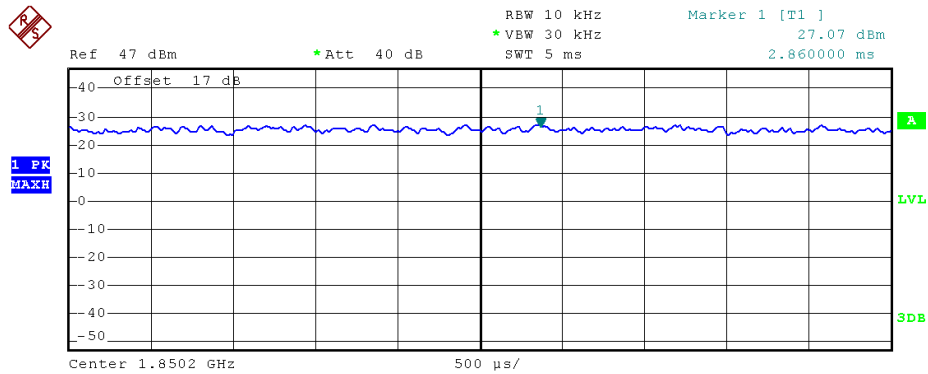

(Plot A1: GPRS 1900 MHz Channel = 512)

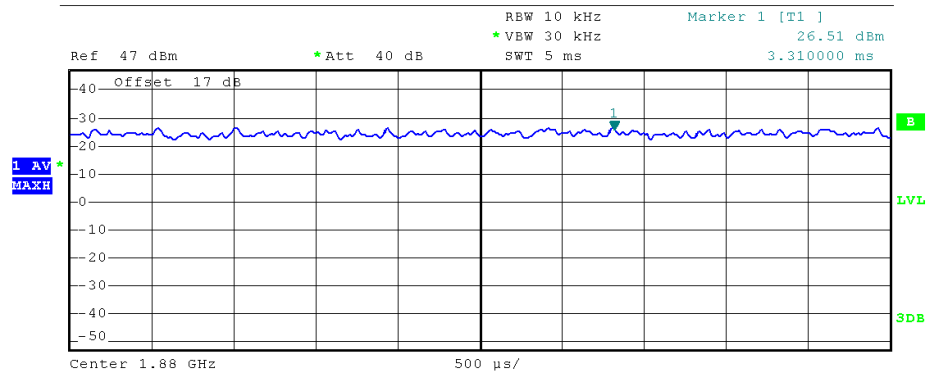
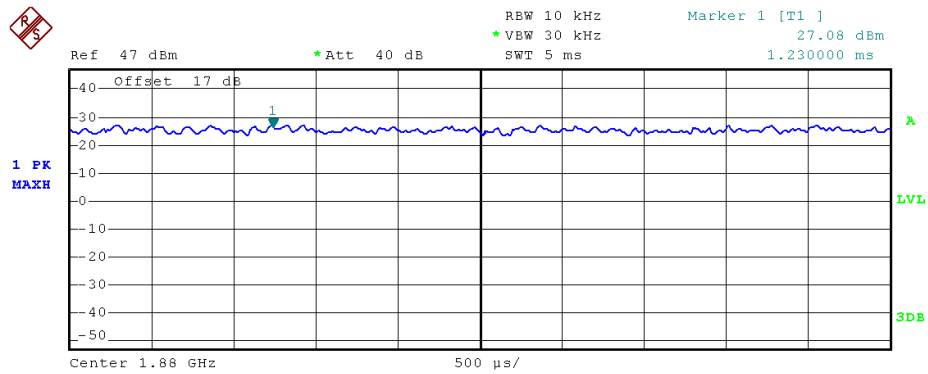

(Plot A2: GPRS 1900 MHz Channel = 661)

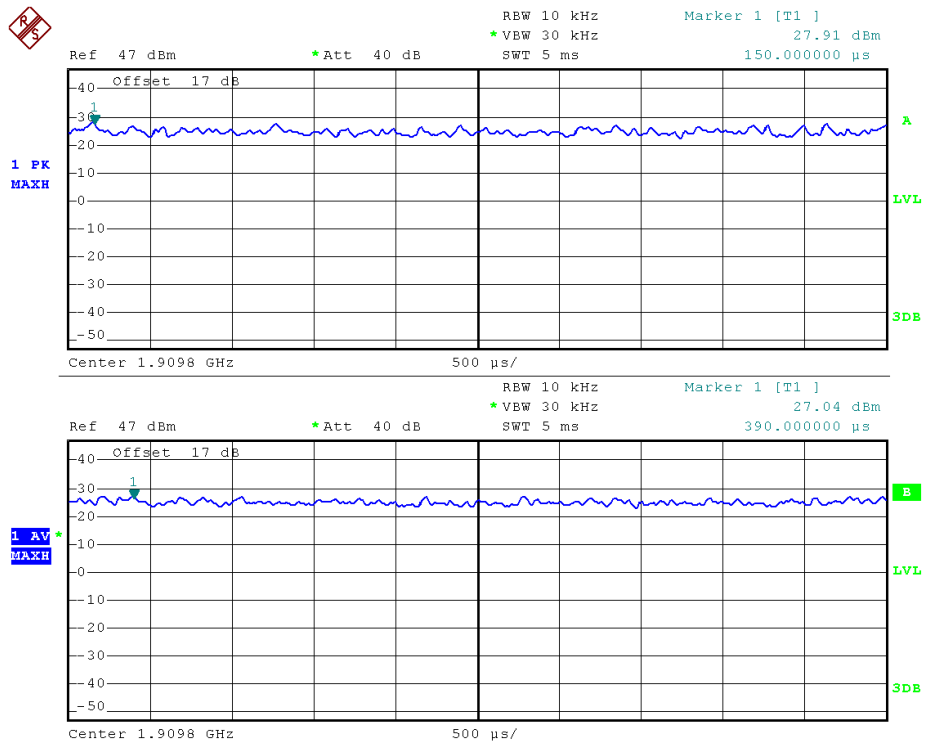

(Plot A3: GPRS 1900MHz Channel = 810)

2.3 99% Occupied Bandwidth and 26dB Bandwidth Measurement

2.3.1 Definition

The 99% occupied bandwidth is the width of a frequency band such that, below the lower and above the upper frequency limits, the mean powers emitted are each equal to a specified percentage 0.5% of the total mean transmitted power.

The emission bandwidth is defined as the width of the signal between two points, located at the 2 sides of the carrier frequency, outside of which all emissions are attenuated at least 26 dB below the transmitter power.

2.3.2 Measuring Instruments

The measuring equipment is listed in the section 3 of this test report.

2.3.3 Test Procedures

1. The testing follows FCC KDB 971168 D01v02r02 Section 4.2.
2. The EUT was connected to the spectrum analyzer and system simulator via a power divider.
3. The RF output of the EUT was connected to the spectrum analyzer by RF cable and attenuator.

The path loss was compensated to the results for each measurement.

4. The 99% occupied bandwidth were measured, set RBW= 1% of span, VBW= 3*RBW, sample detector, trace maximum hold.

5. The 26dB bandwidth were measured, set RBW= 1% of EBW, VBW= 3*RBW, peak detector, trace maximum hold.

2.3.4 Test Setup

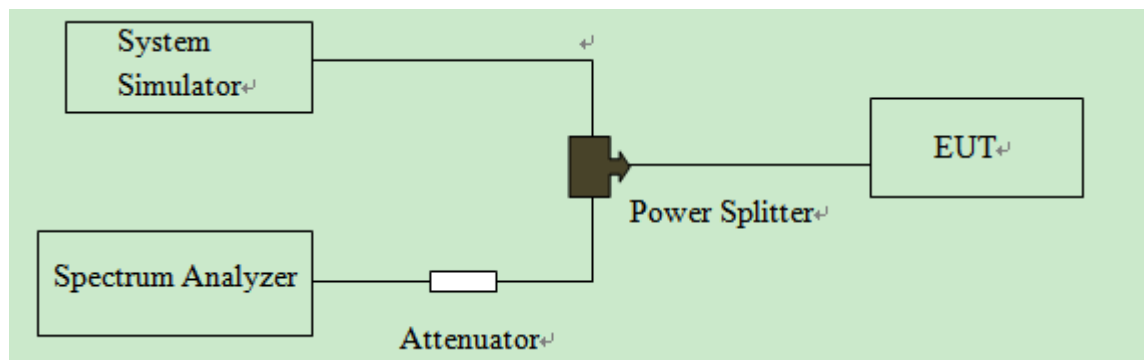

**2.3.5 Test Results of 99% Occupied Bandwidth and 26dB Bandwidth**

Band	Channel	Frequency (MHz)	26dB bandwidth	99% Occupied Bandwidth	Refer to Plot
GPRS 850MHz	128	824.2	316 kHz	246 kHz	Plot A1-A2
	190	836.6	316 kHz	244 kHz	Plot A3-A4
	251	848.8	314 kHz	242 kHz	Plot A5-A6
GPRS 1900MHz	512	1850.2	314 kHz	246 kHz	Plot B1-B2
	661	1880.0	310 kHz	242 kHz	Plot B3-B4
	810	1909.8	314 kHz	248 kHz	Plot B5-B6

2.3.6 Test Results (Plots) of 99% Occupied Bandwidth and 26dB Bandwidth

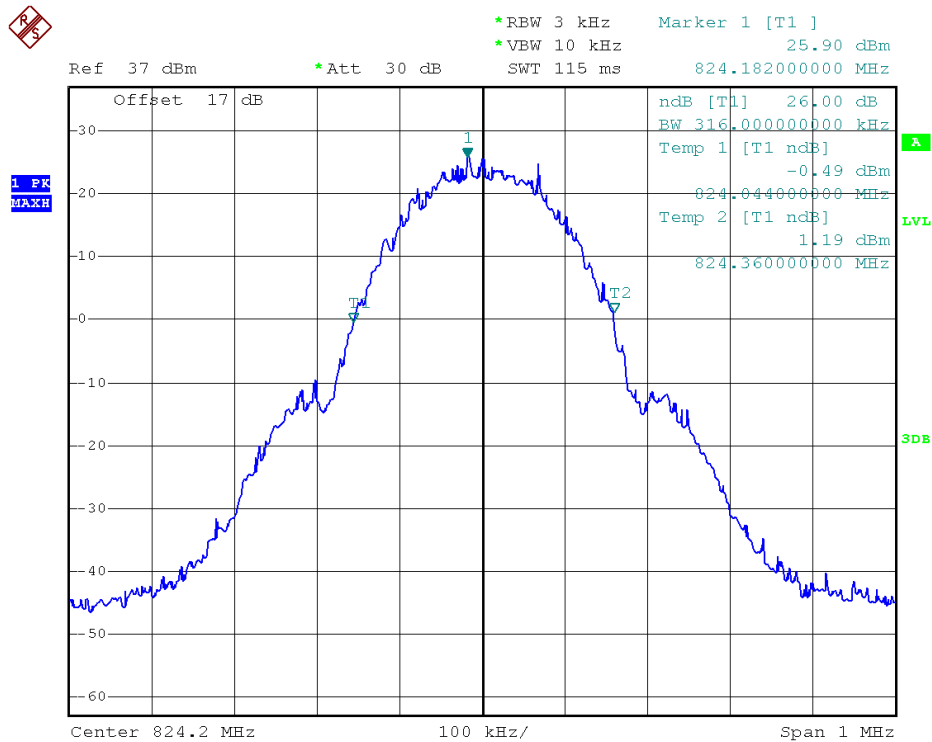

(Plot A1: GPRS 850MHz Channel = 128 26dB bandwidth)

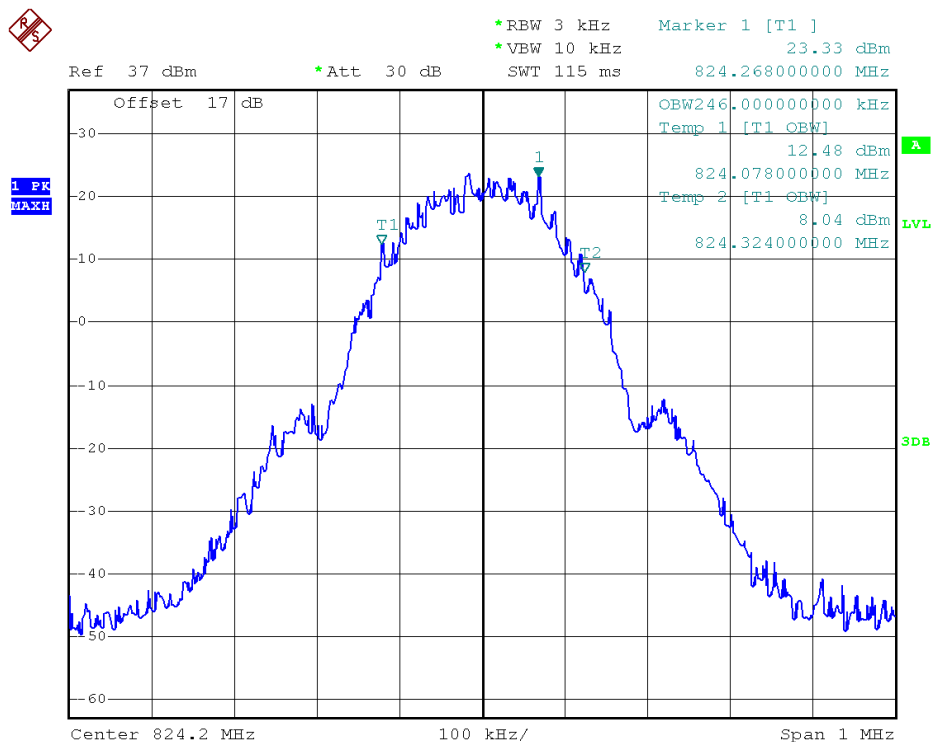

(Plot A2: GPRS 850MHz Channel = 128 99% Occupied Bandwidth)

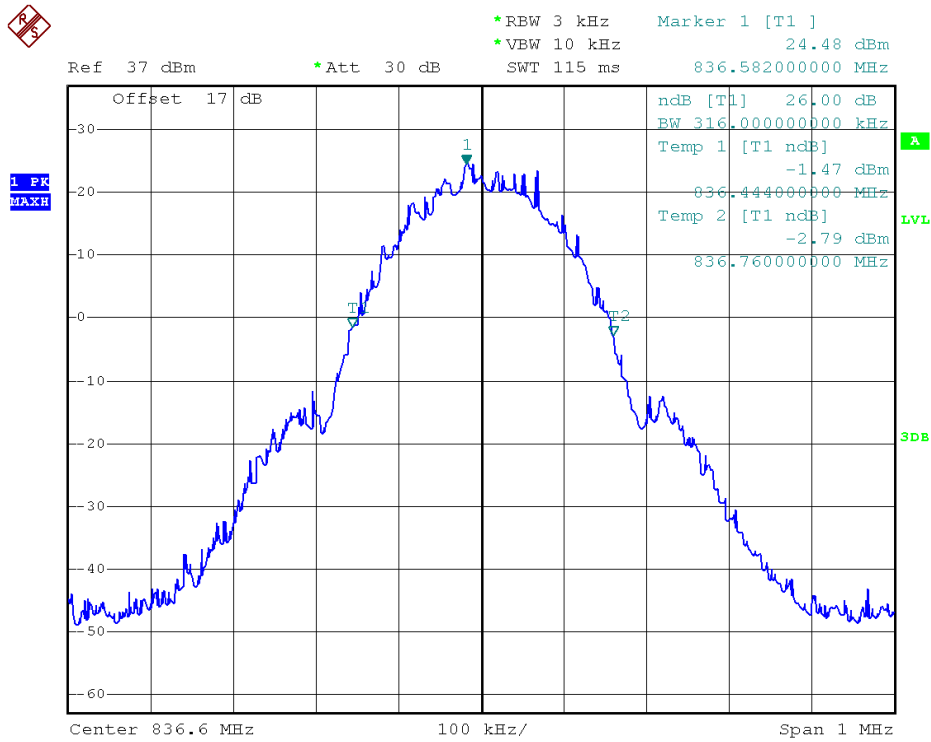

(Plot A3: GPRS 850MHz Channel = 190 26dB bandwidth)

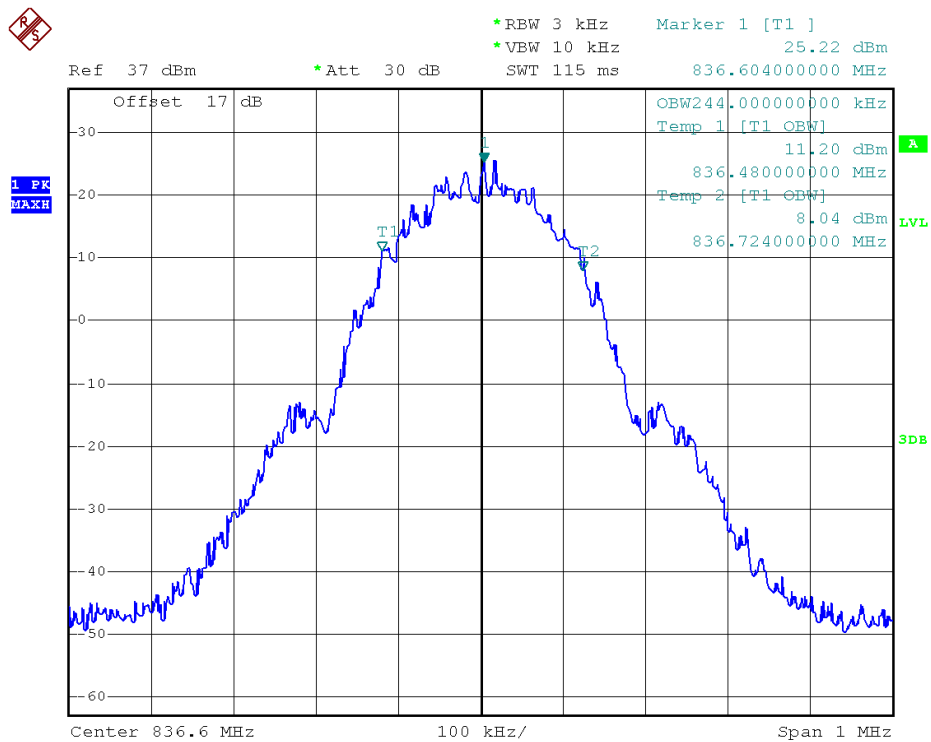

(Plot A4: GPRS 850MHz Channel = 190 99% Occupied Bandwidth)

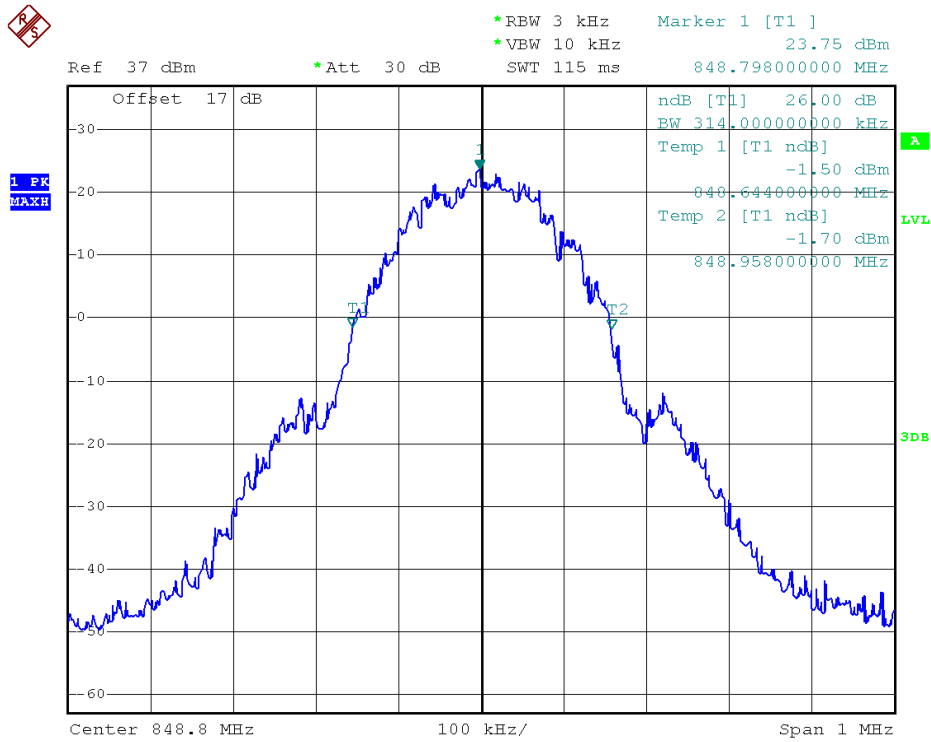

(Plot A5: GPRS 850MHz Channel = 251 26dB bandwidth)

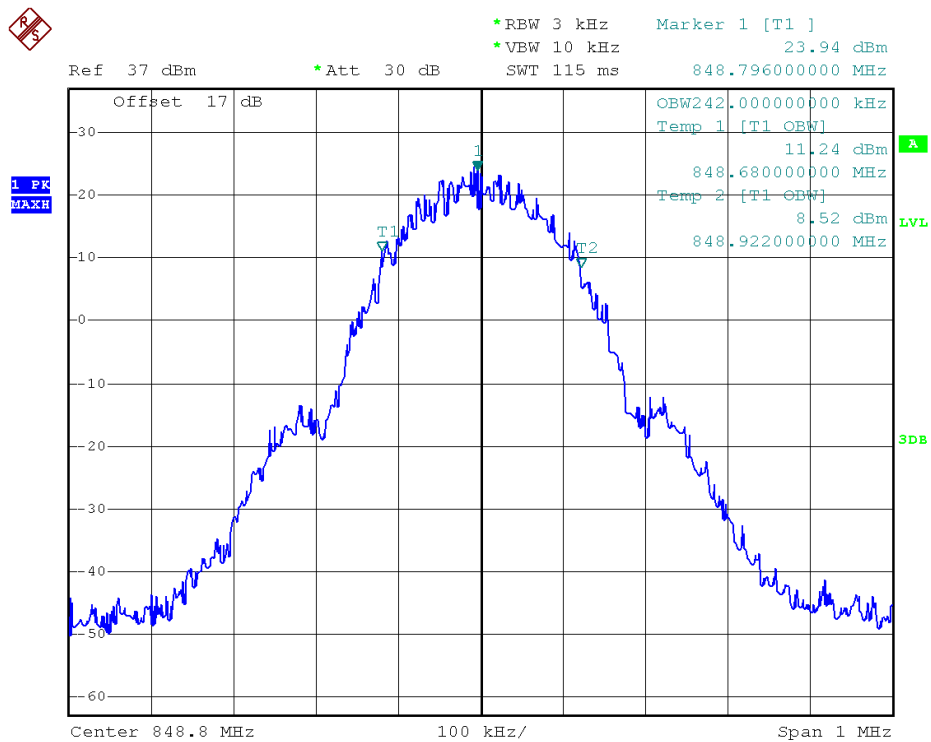

(Plot A6: GPRS 850MHz Channel = 251 99% Occupied Bandwidth)

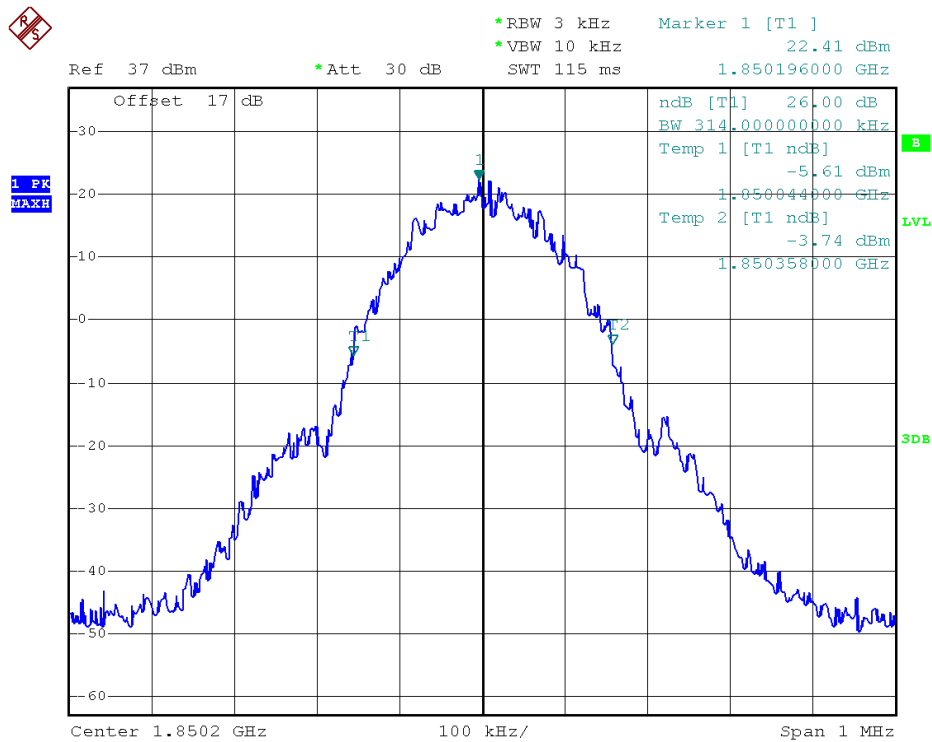

(Plot B1: GPRS 1900MHz Channel = 512 26dB bandwidth)

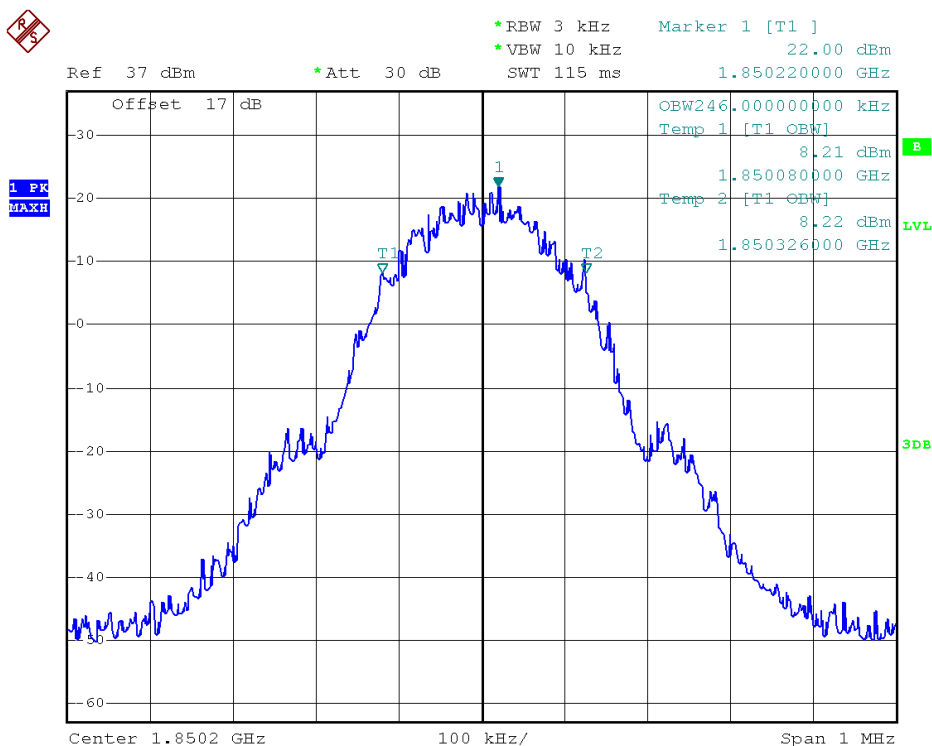

(Plot B2: GPRS 1900MHz Channel = 512 99% Occupied Bandwidth)

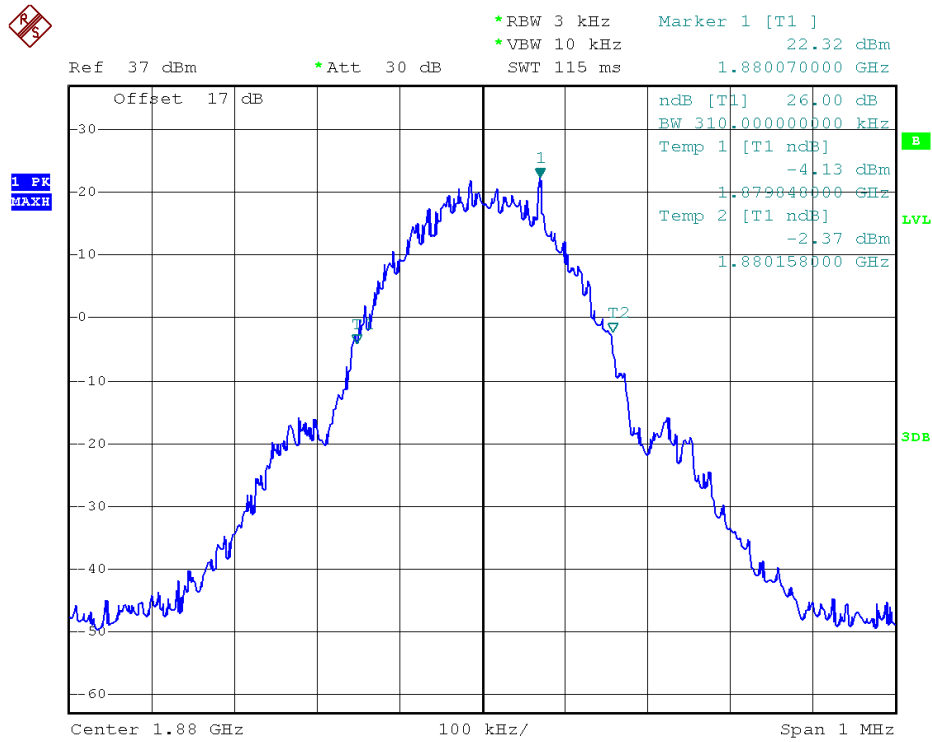

(Plot B3: GPRS 1900MHz Channel = 661 26dB bandwidth)

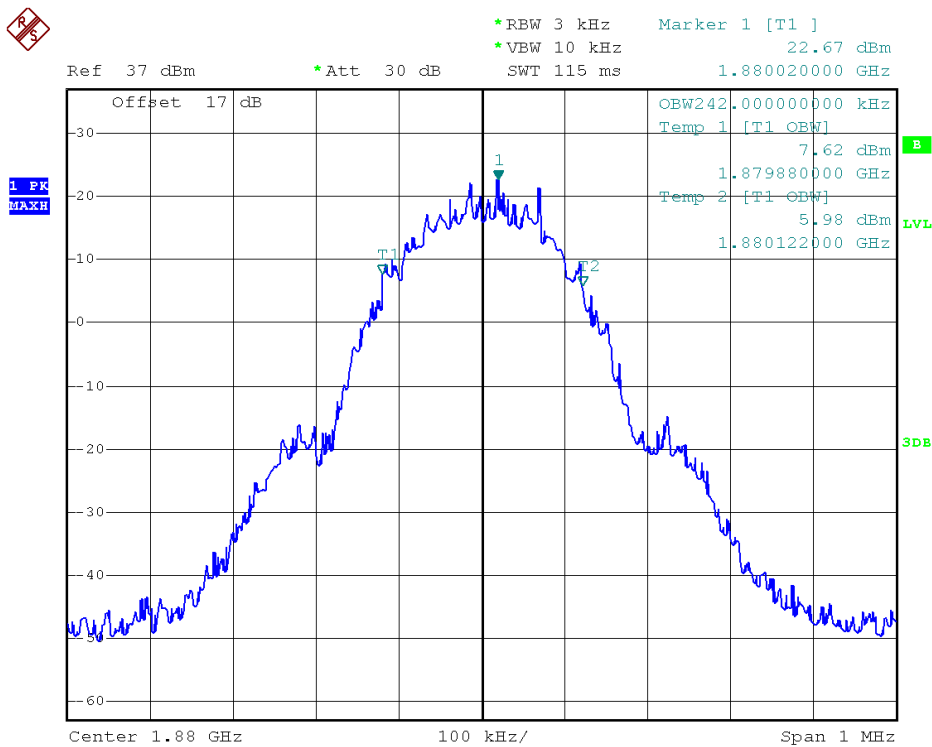

(Plot B4: GPRS 1900MHz Channel = 661 99% Occupied Bandwidth)

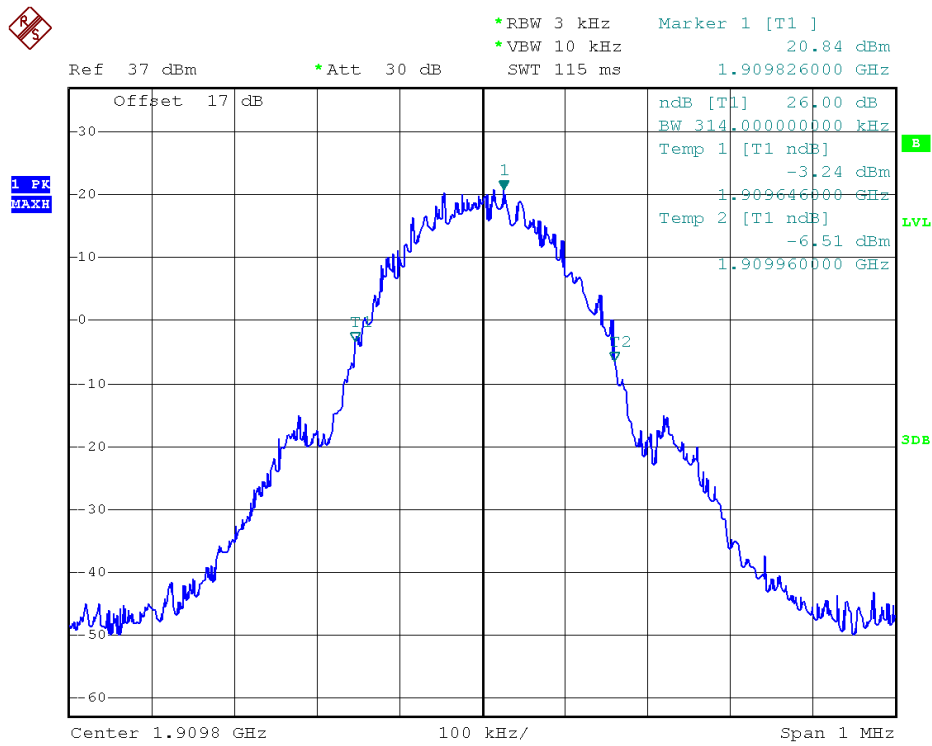

(Plot B5: GPRS 1900MHz Channel = 810 26dB bandwidth)

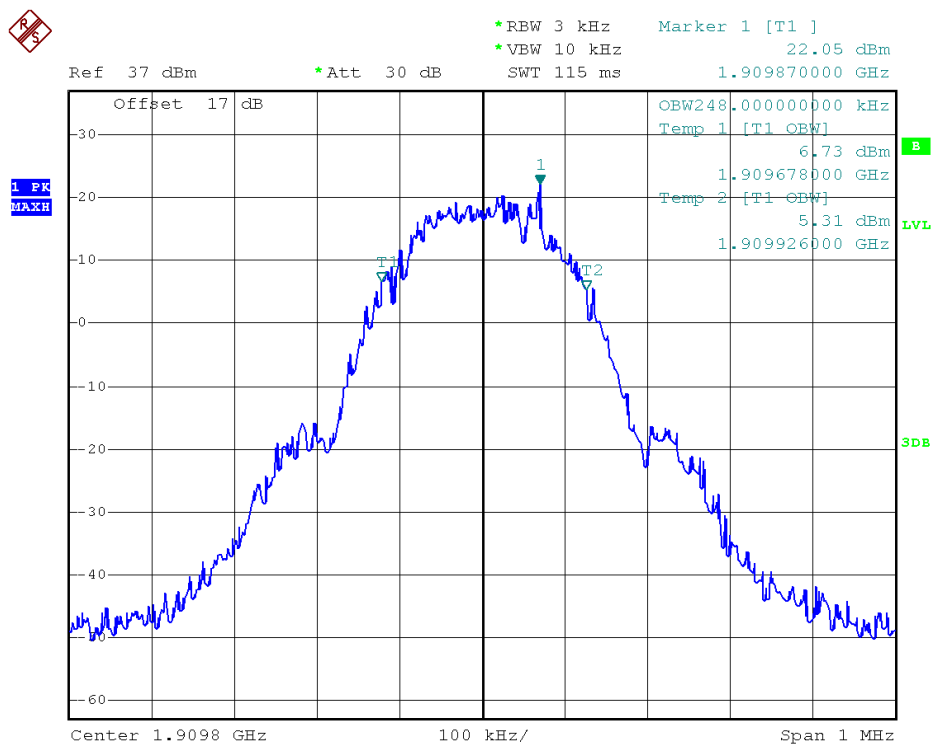

(Plot B6: GPRS 1900MHz Channel = 810 99% Occupied Bandwidth)

2.4 Frequency Stability

2.4.1 Requirement

The frequency stability shall be measured by variation of ambient temperature and variation of primary supply voltage to ensure that the fundamental emission stays within the authorized frequency block. The frequency stability of the transmitter shall be maintained within $\pm 0.00025\%$ ($\pm 2.5\text{ppm}$) of the center frequency.

2.4.2 Measuring Instruments

The measuring equipment is listed in the section 3 of this test report.

2.4.3 Test Procedures for Temperature Variation

1. The testing follows FCC KDB 971168 D01v02r02 Section 9.0.
2. The EUT was set up in the thermal chamber and connected with the system simulator.
3. With power OFF, the temperature was decreased to -30°C and the EUT was stabilized before testing. Power was applied and the maximum change in frequency was recorded within one minute.
4. With power OFF, the temperature was raised in 10°C steps up to 50°C . The EUT was stabilized at each step for at least half an hour. Power was applied and the maximum frequency change was recorded within one minute.

2.4.4 Test Procedures for Voltage Variation

1. The testing follows FCC KDB 971168 D01v02r02 Section 9.0.
2. The EUT was placed in a temperature chamber at $25\pm 5^{\circ}\text{C}$ and connected with the system simulator.
3. The power supply voltage to the EUT was varied from BEP to 115% of the nominal value measured at the input to the EUT.
4. The variation in frequency was measured for the worst case.

2.4.5 Test Setup

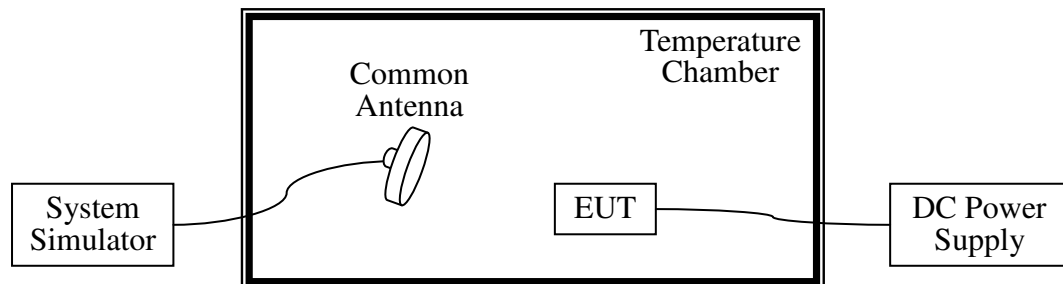

2.4.6 Test Results of Frequency Stability

1. GPRS 850MHz Band

Band:	GPRS 850	Channel:	190
Limit(ppm):	2.5	Frequency:	836.6MHz

Power (VDC)	Temperature (°C)	GPRS 850		Result
		Freq. Dev. (Hz)	Deviation (ppm)	
3.7	-30	17	0.02	PASS
	-20	10	0.01	
	-10	25	0.03	
	0	15	0.02	
	+10	12	0.01	
	+20	18	0.02	
	+30	17	0.02	
	+40	25	0.03	
	+50	8	0.01	
4.2	+25	11	0.01	
3.5	+25	26	0.03	



2. GPRS 1900MHz Band

Band:	GPRS 1900	Channel:	661
Limit(ppm):	2.5	Frequency:	1880.0MHz

Power (VDC)	Temperature (°C)	GPRS		Result
		Freq. Dev. (Hz)	Deviation (ppm)	
3.7	-30	38	0.02	PASS
	-20	47	0.02	
	-10	26	0.01	
	0	57	0.03	
	+10	44	0.02	
	+20	22	0.01	
	+30	41	0.02	
	+40	56	0.03	
	+50	25	0.01	
4.2	+25	58	0.03	
3.5	+25	22	0.01	

2.5 Conducted Out of Band Emissions

2.5.1 Requirement

The power of any emission outside of the authorized operating frequency ranges must be lower than the transmitter power (P) by a factor of at least $43 + 10 \log (P)$ dB.

It is measured by means of a calibrated spectrum analyzer and scanned from 30 MHz up to a frequency including its 10th harmonic.

2.5.2 Measuring Instruments

The measuring equipment is listed in the section 3 of this test report.

2.5.3 Test Procedures

1. The testing follows FCC KDB 971168 D01v02r02 Section 6.0.
2. The EUT was connected to the spectrum analyzer and system simulator via a power divider.
3. The RF output of EUT was connected to the spectrum analyzer by an RF cable and attenuator. The path loss was compensated to the results for each measurement.
4. The middle channel for the highest RF power within the transmitting frequency was measured.
5. The conducted spurious emission for the whole frequency range was taken.
6. The RF fundamental frequency should be excluded against the limit line in the operating frequency band.
7. The limit line is derived from $43 + 10\log(P)$ dB below the transmitter power P(Watts)
 $= P(W) - [43 + 10\log(P)]$ (dB)
 $= [30 + 10\log(P)]$ (dBm) - $[43 + 10\log(P)]$ (dB)
 $= -13\text{dBm}$.
8. For 9KHz to 30MHz: the amplitude of spurious emissions are attenuated by more than 20dB below the permissible value has no need to be reported.

2.5.4 Test Setup

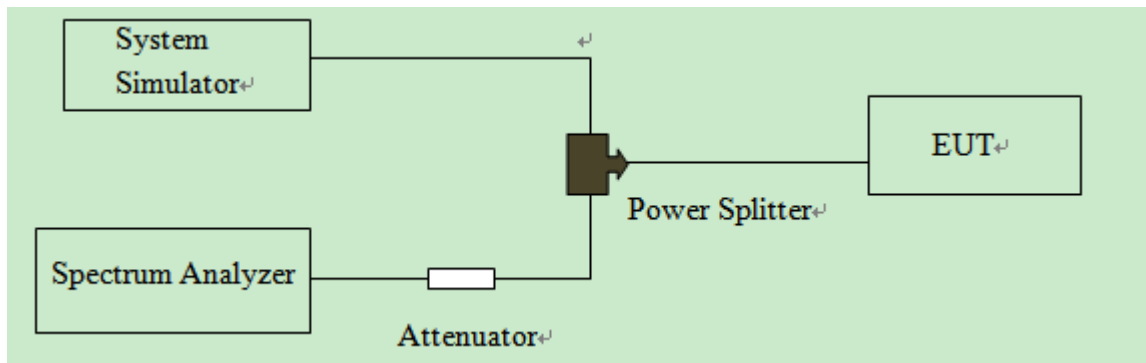



2.5.5 Test Result (Plots) of Conducted Spurious Emission

Note: For 9 KHz to 30MHz: the amplitude of spurious emissions is attenuated by more than 20dB below the permissible value, so we not provide the test result here.

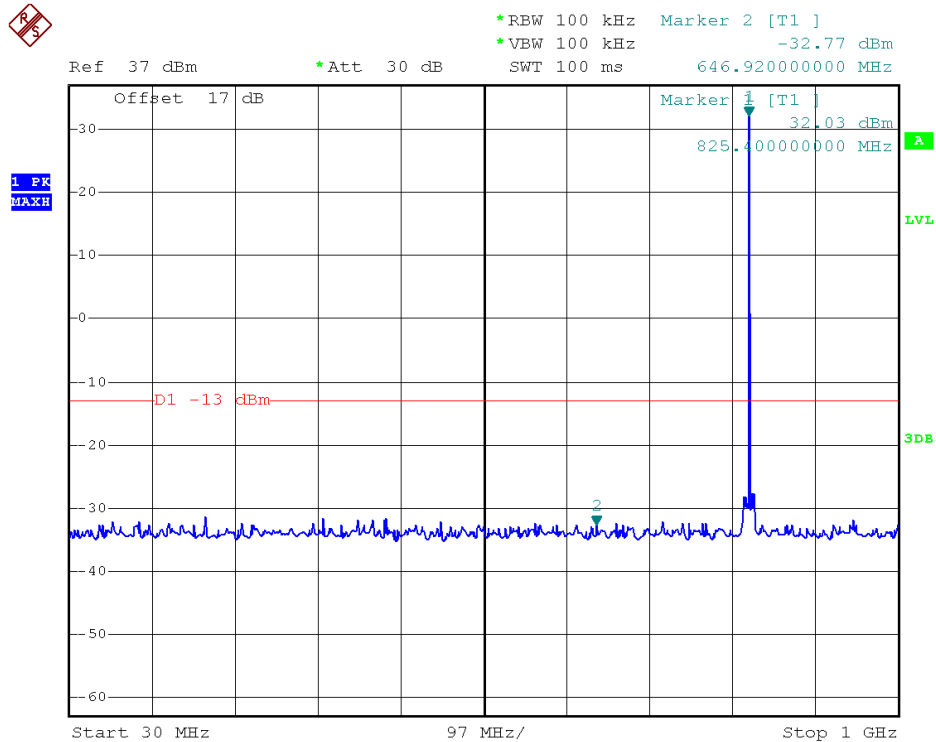

GPRS 850MHz Channel = 128, 30MHz to 1GHz

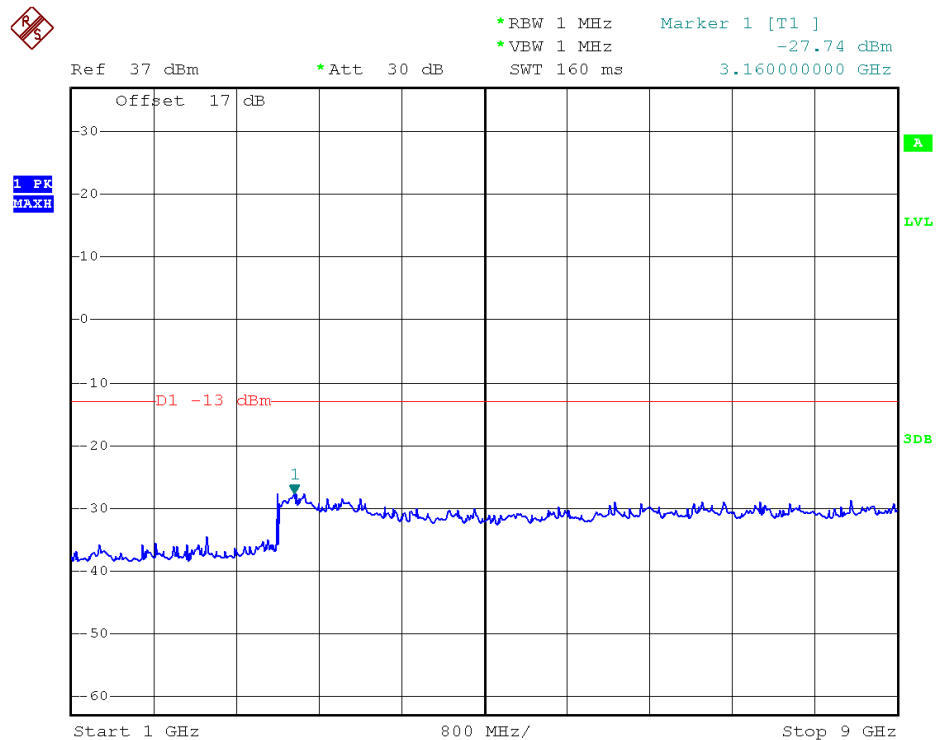

GPRS 850MHz Channel = 128, 1GHz to 9GHz

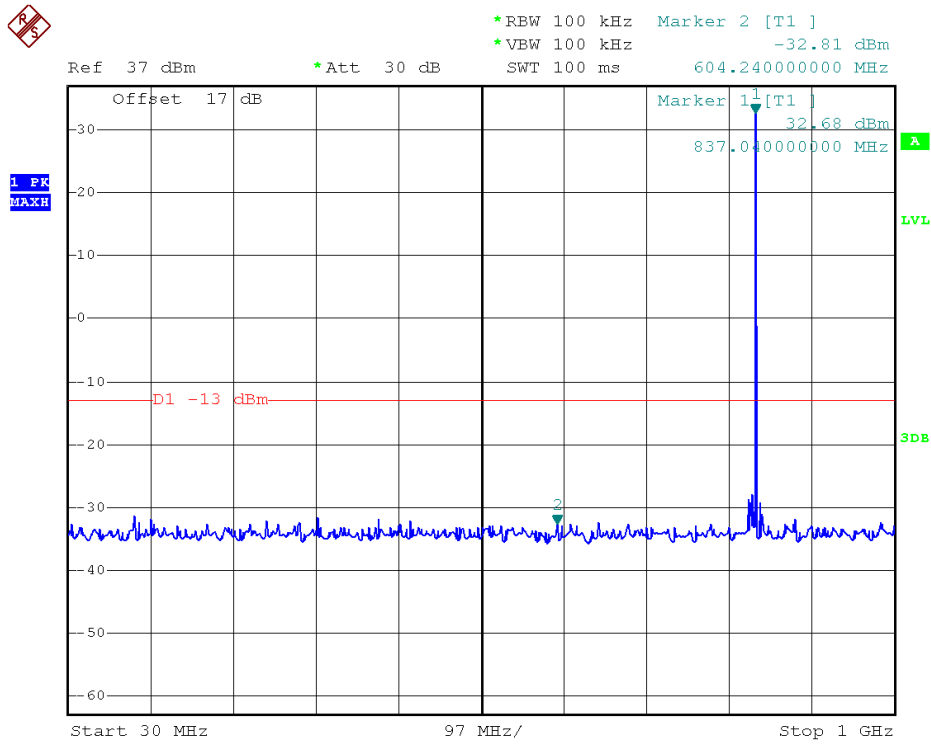

GPRS 850MHz Channel = 190, 30MHz to 1GHz

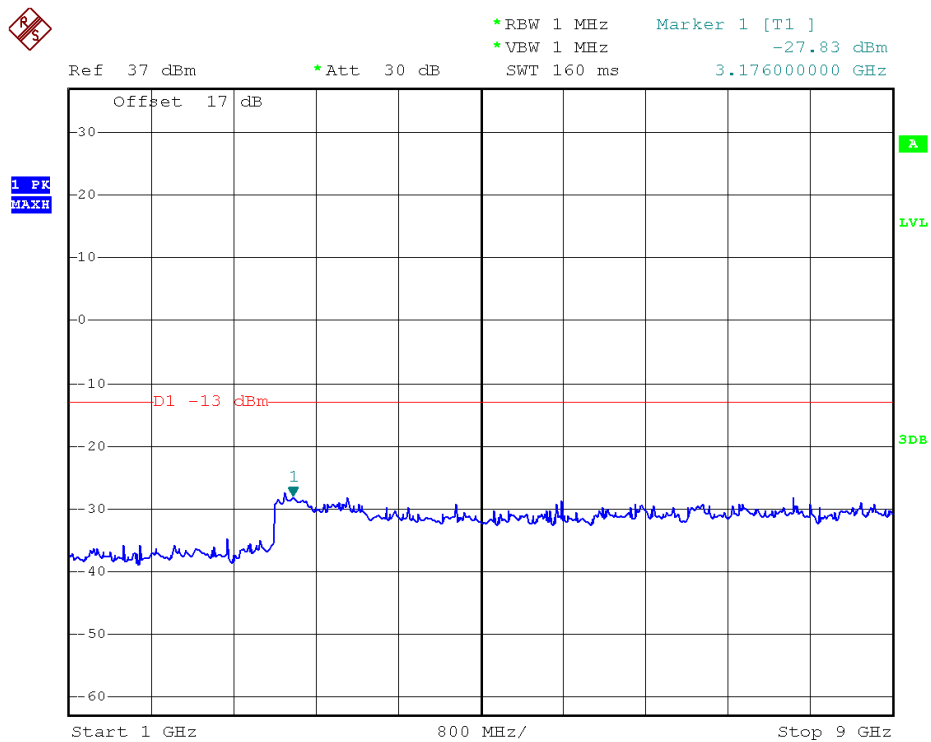

GPRS 850MHz Channel = 190, 1GHz to 9GHz

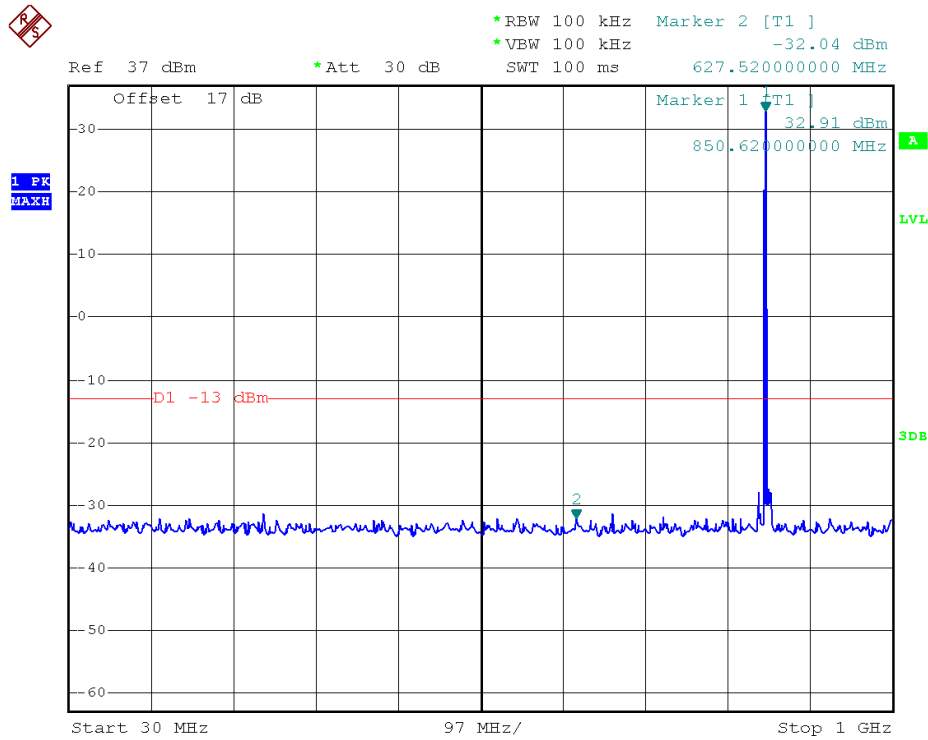

GPRS 850MHz Channel = 251, 30MHz to 1GHz

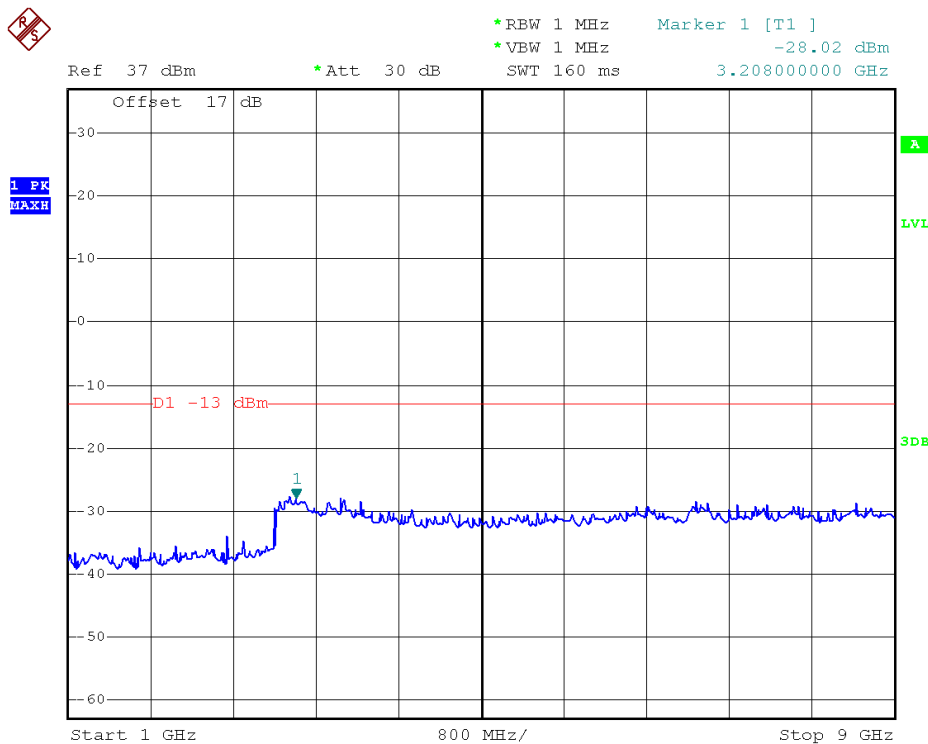

GPRS 850MHz Channel = 251, 1GHz to 9GHz

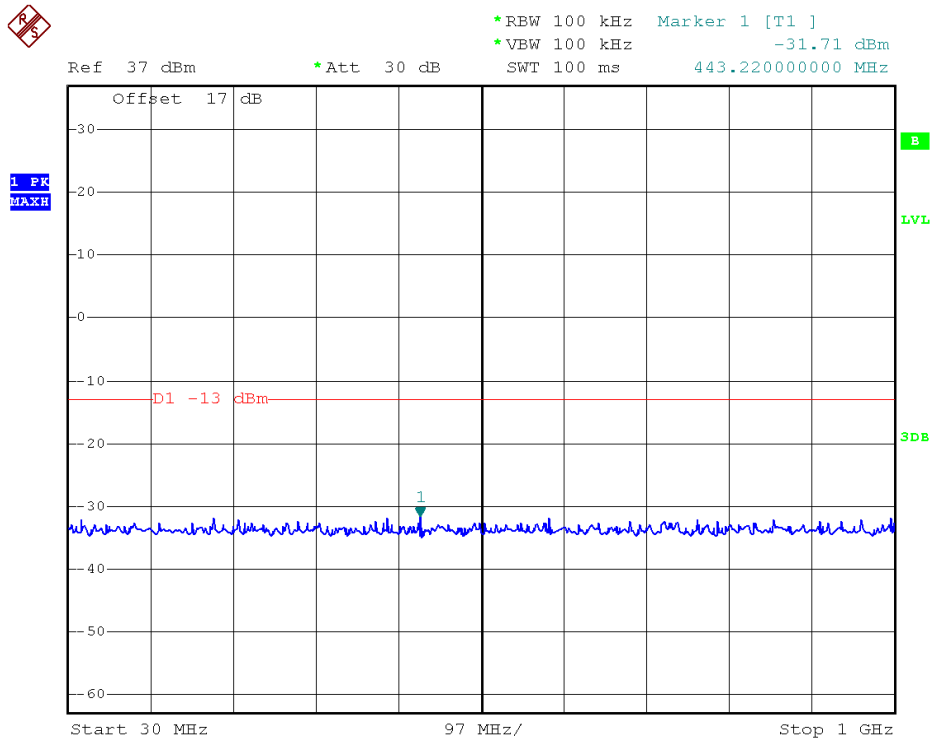

GPRS 1900MHz Channel = 512, 30MHz to 1GHz

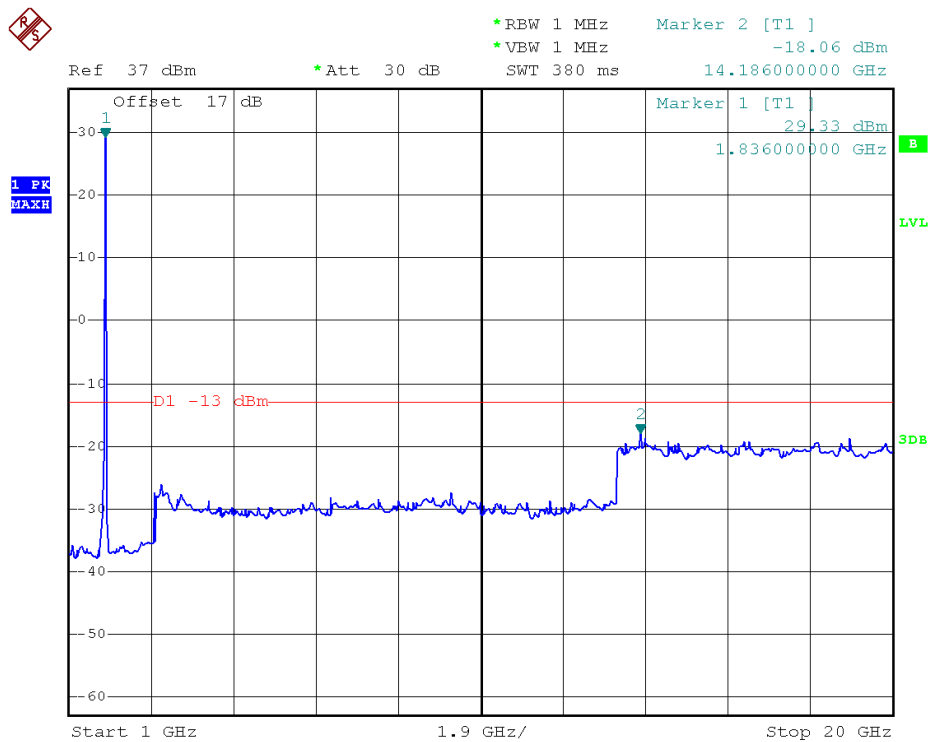

GPRS 1900MHz Channel = 512, 1GHz to 20GHz

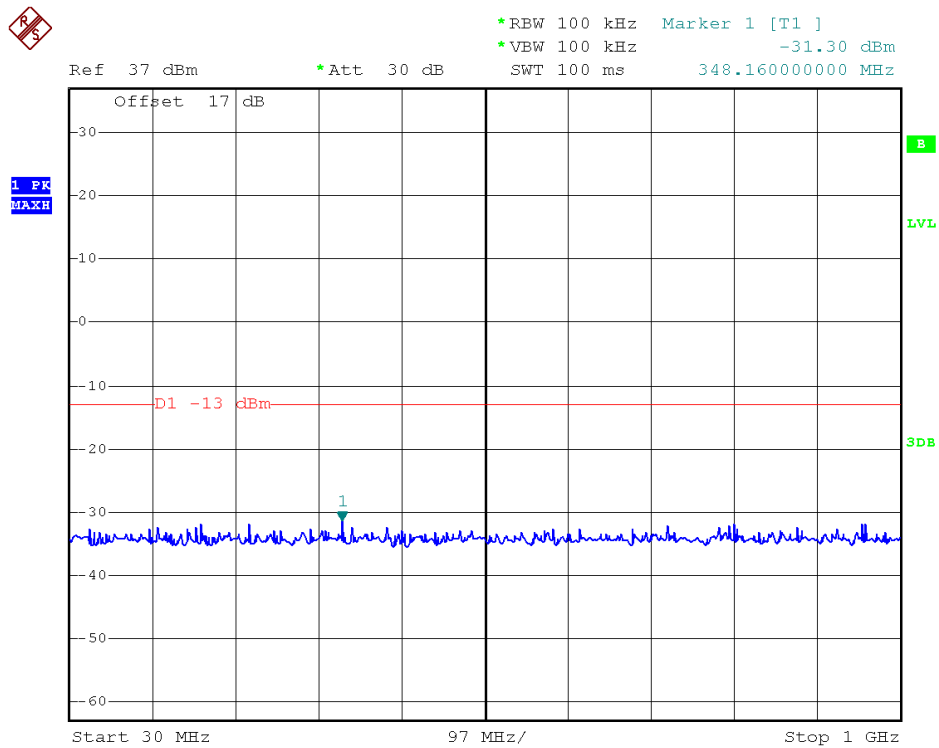

GPRS 1900MHz Channel = 661, 30MHz to 1GHz

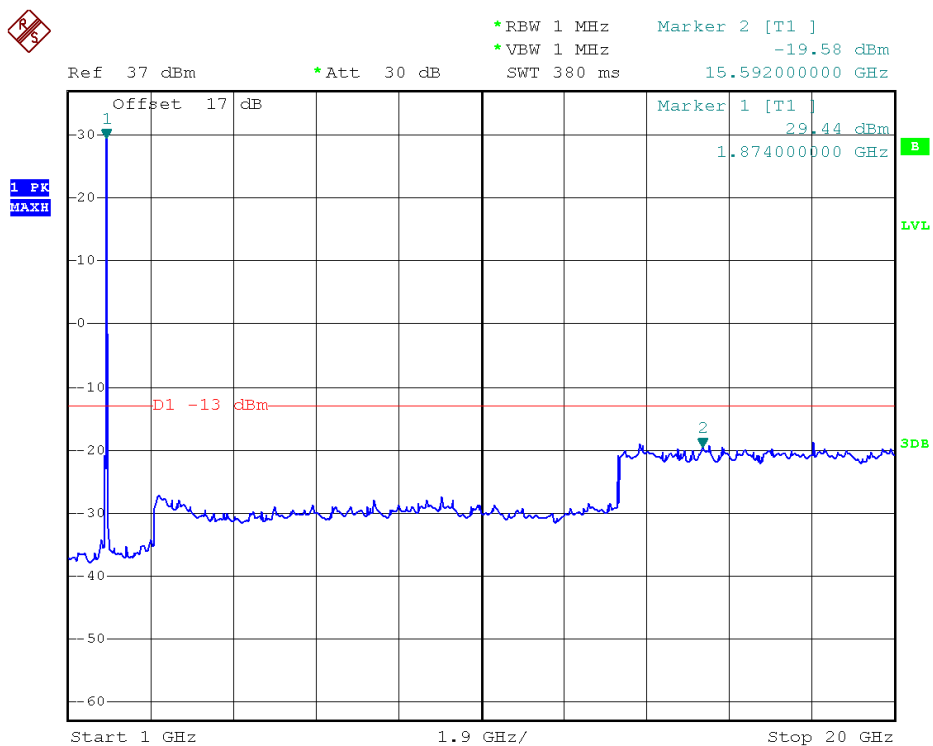

GPRS 1900MHz Channel = 661, 1GHz to 20GHz

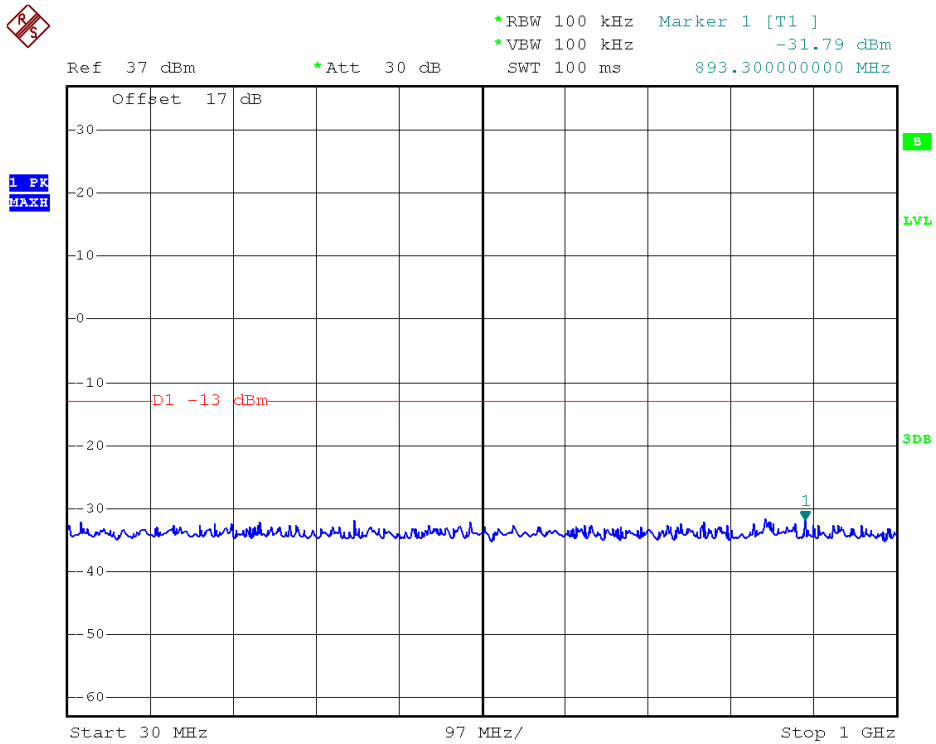

GPRS 1900MHz Channel = 810, 30MHz to 1GHz

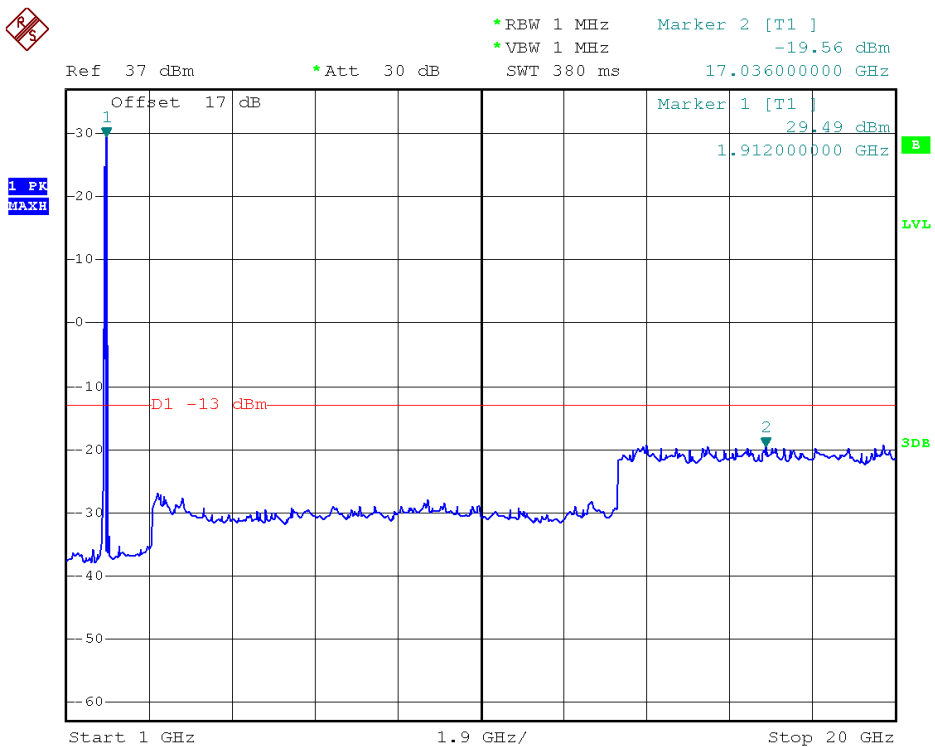

GPRS 1900MHz Channel = 810, 1GHz to 20GHz

2.6 Band Edge

2.6.1 Requirement

The power of any emission outside of the authorized operating frequency ranges must be lower than the transmitter power (P) by a factor of at least $43 + 10 \log (P)$ dB.

2.6.2 Measuring Instruments

The measuring equipment is listed in the section 3 of this test report.

2.6.3 Test Procedures

1. The testing follows FCC KDB 971168 D01v02r02 Section 6.0.
2. The EUT was connected to the spectrum analyzer and system simulator via a power divider.
3. The RF output of EUT was connected to the spectrum analyzer by an RF cable and attenuator. The path loss was compensated to the results for each measurement.
4. The band edges of low and high channels for the highest RF powers were measured.
5. The RF fundamental frequency should be excluded against the limit line in the operating frequency band.
6. The limit line is derived from $43 + 10\log(P)$ dB below the transmitter power P(Watts)

$$= P(W) - [43 + 10\log(P)] \text{ (dB)}$$

$$= [30 + 10\log(P)] \text{ (dBm)} - [43 + 10\log(P)] \text{ (dB)}$$

$$= -13\text{dBm}.$$

2.6.4 Test Setup

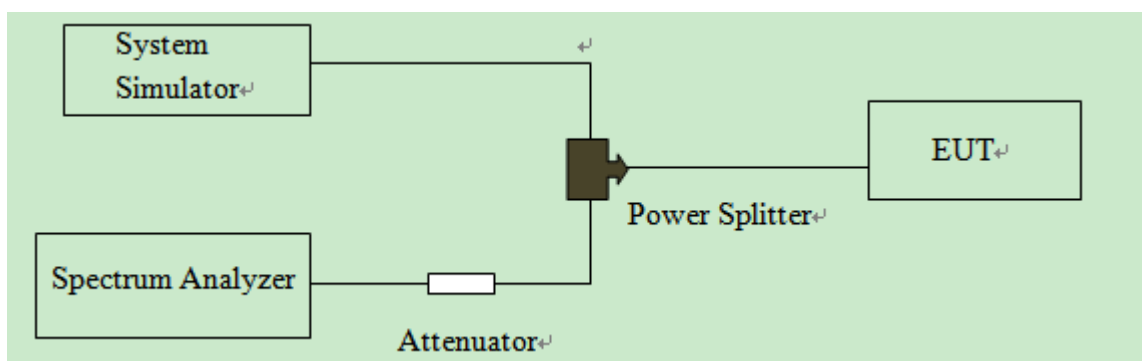

**2.6.5 Test Result of Conducted Band Edge**

Band	Channel	Frequency (MHz)	Measured Max. Band Edge Emission (dBm)	Refer to Plot	Limit (dBm)	Verdict
GPRS 850MHz	128	824.2	-14.59	Plat A	-13	PASS
	251	848.8	-13.83	Plot B		PASS
GPRS 1900MHz	512	1850.2	-15.67	Plat C	-13	PASS
	810	1909.8	-16.14	Plot D		PASS

2.6.6 Test Result (Plots) of Conducted Band Edge

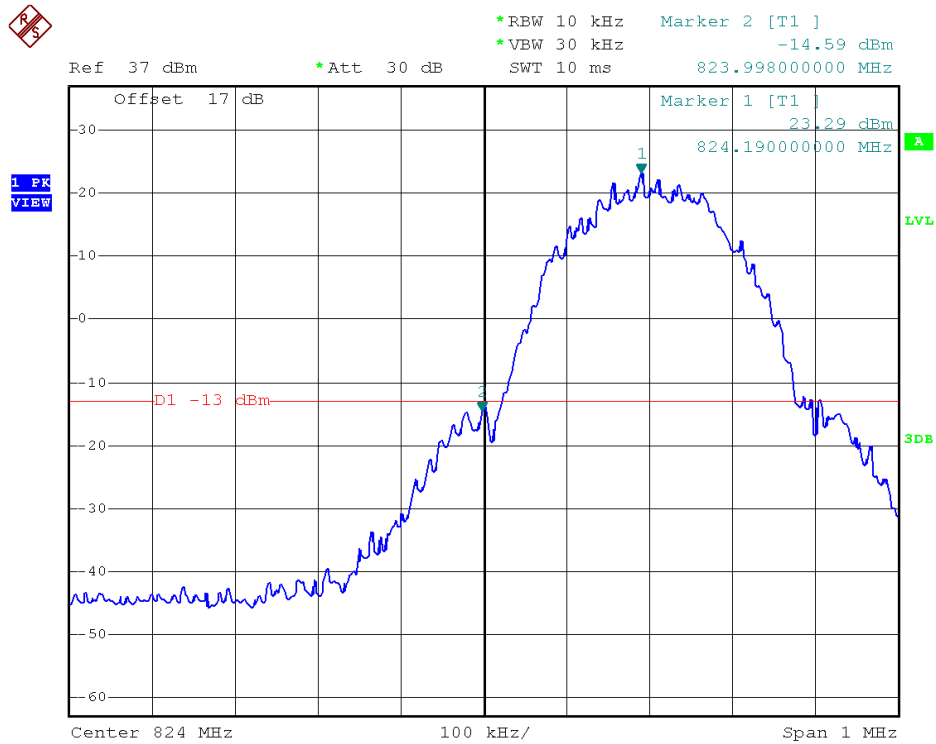

(Plot A: GPRS 850 Channel = 128)

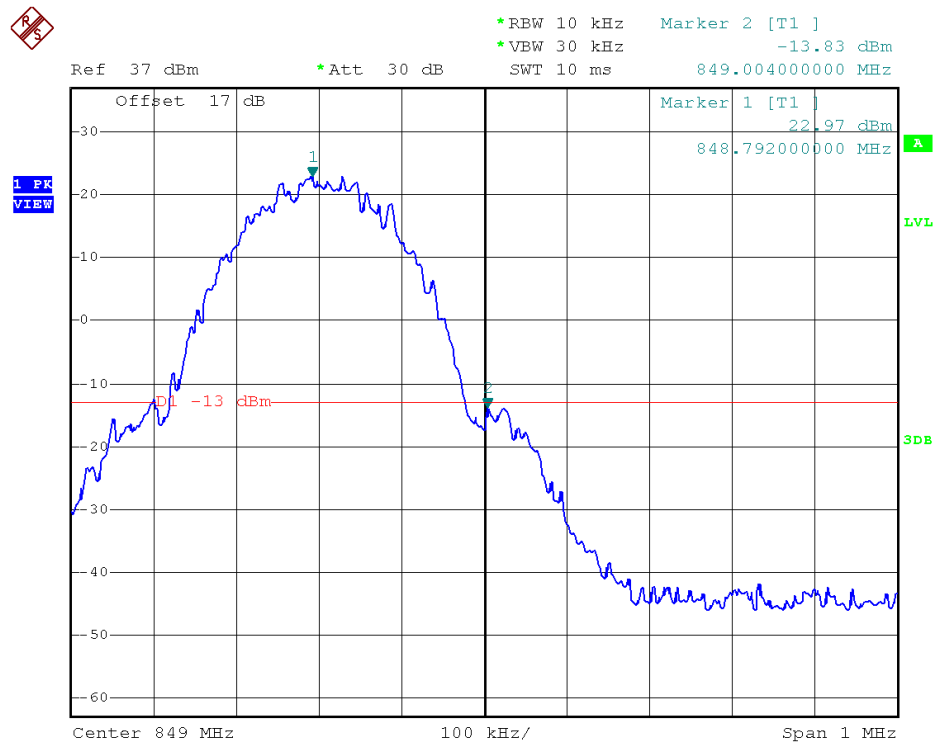

(Plot B: GPRS 850 Channel = 251)

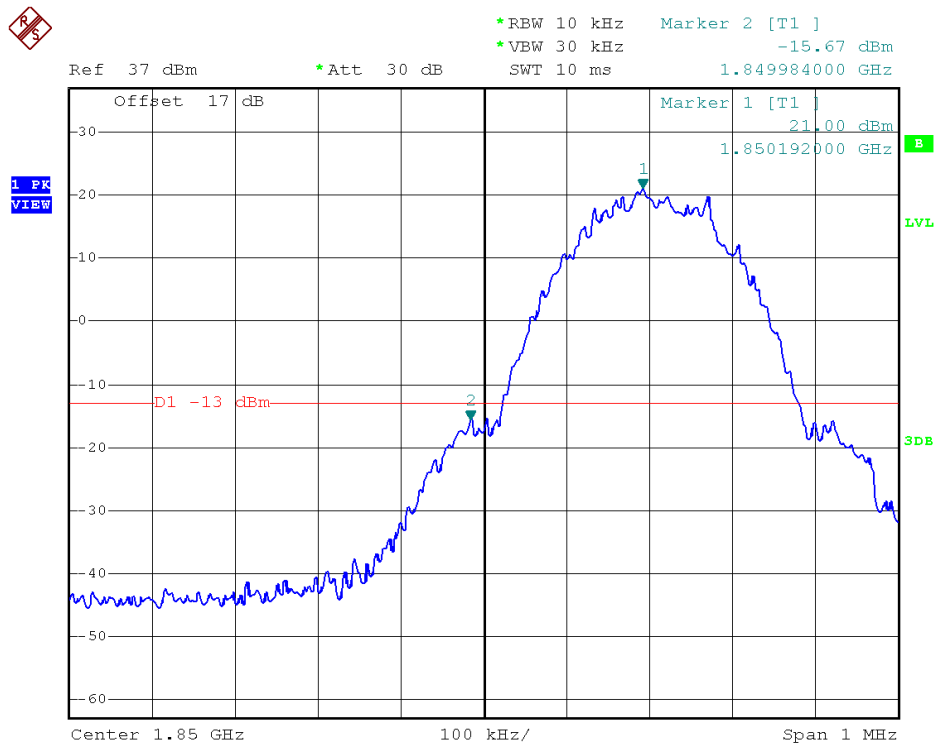

(Plot C: GPRS 1900 Channel = 512)

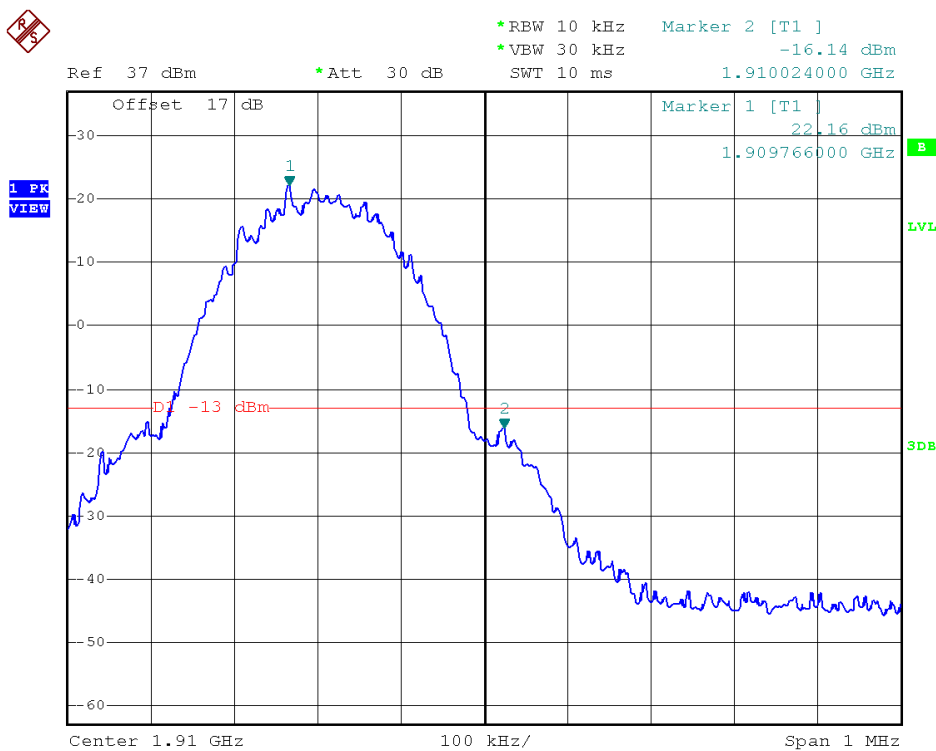

(Plot D: GPRS 1900 Channel = 810)

2.7 Transmitter Radiated Power (EIRP/ERP)

2.7.1 Requirement

The substitution method, in ANSI / TIA / EIA-603-D-2010, was used for ERP/EIRP measurement, and the spectrum analyzer configuration follows KDB 971168 D01 Power Meas. License Digital Systems v02r02. The ERP of mobile transmitters must not exceed 7 Watts (Cellular Band) and the EIRP of mobile transmitters are limited to 2 Watts (PCS Band) and 1 Watts (AWS Band).

2.7.2 Measuring Instruments

The measuring equipment is listed in the section 3 of this test report.

2.7.3 Test Procedures

1. The EUT was placed on a turntable with 1.5 meter height on a wooden turntable in a fully anechoic chamber.
2. The EUT was set at 3 meters from the receiving antenna, which was mounted on the antenna tower.
3. The radiated emission at the fundamental frequency was measured at 3 m with a test antenna and a spectrum analyzer which used a channel power option across EUT's signal bandwidth per section 4.0 of KDB 971168 D01v02r02.
4. The table was rotated 360 degrees and Both Horizontal & Vertical antenna polarities were tested and performed pretest to three orthogonal axis. The worst case emissions were reported.
5. The height of the receiving antenna is adjusted to look for the maximum value.
6. Taking the record of maximum value on spectrum analyzer.
7. Remove the EUT and replace it with substitution antenna. A signal generator was connected to the substitution antenna by a non-radiating cable. The absolute levels of the spurious emissions were measured by the substitution.
8. A Broadband antenna (for below 1GHz) and horn antenna (for above 1GHz) was substituted in place of the EUT and was driven by a signal generator.
9. The conducted power at the terminal of the antenna is measured.
10. Repeat step 3 to step 9 to get the maximum ERP/EIRP of the substitution antenna.

$$11. \text{ERP/EIRP} = P_s + E_t - E_s + G_s = P_s + R_t - R_s + G_s$$

P_s (dBm): Input power to substitution antenna.

G_s (dBi or dBd): Substitution antenna Gain.

$$E_t = R_t + \text{AF} \quad E_s = R_s + \text{AF}$$

AF (dB/m): Receive antenna factor

R_t : The highest received signal in spectrum analyzer for EUT.

R_s : The highest received signal in spectrum analyzer for substitution antenna.

2.7.4 Test Setup

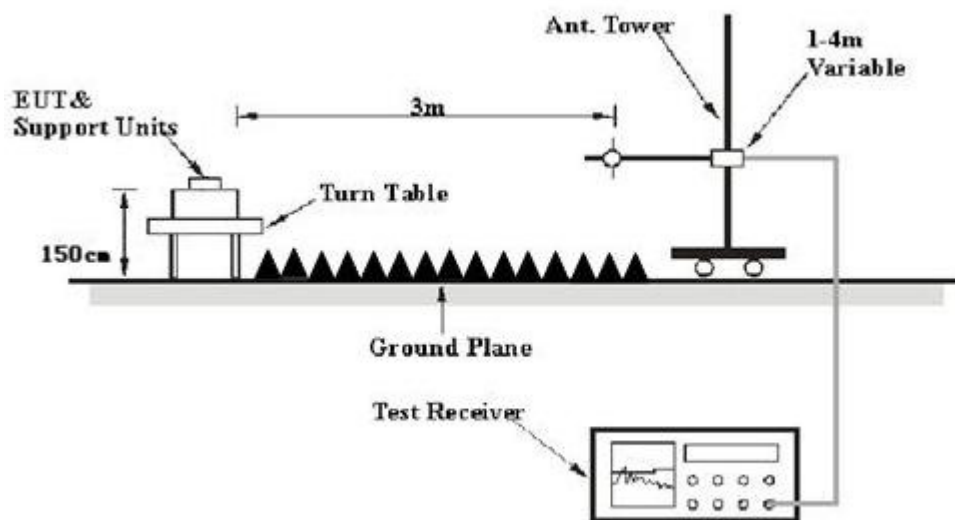



2.7.5 Test Result of Transmitter Radiated Power

Test Notes:

1. This device employs GMSK technology with GSM and GPRS capabilities. All configurations were investigated and the worst case emissions were found in GRPS 8 mode.
2. This unit was tested with its standard battery.
3. The worst case test configuration was found in the vertical positioning where the EUT is laying on its side. The data reported in the tables below were measured in this test setup.

Band	Channel	Frequency (MHz)	PCL	Antenna Pol (H/V)	Measured ERP dBm	Limit dBm	Verdict
GPRS 850MHz (GPRS 8)	128	824.20	5	V	31.28	38.5	PASS
				H	31.24		
	190	836.60	5	V	31.32		PASS
				H	31.30		
	251	848.80	5	V	31.33		PASS
				H	31.28		

Band	Channel	Frequency (MHz)	PCL	Antenna Pol (H/V)	Measured EIRP dBm	Limit dBm	Verdict
GPRS 1900MHz (GPRS 8)	512	1850.2	0	V	28.04	33	PASS
				H	28.10		
	661	1880.0	0	V	28.12		PASS
				H	28.07		
	810	1909.8	0	V	28.08		PASS
				H	28.09		

2.8 Radiated Spurious Emissions

2.8.1 Requirement

The power of any emission outside of the authorized operating frequency ranges must be attenuated below the transmitter power (P) by a factor of at least $43 + 10 \log (P)$ dB. The spectrum is scanned from 30 MHz up to a frequency including its 10th harmonic.

2.8.2 Measuring Instruments

The measuring equipment is listed in the section 3 of this test report.

2.8.3 Test Setup

For radiated emissions from 9 kHz to 30MHz

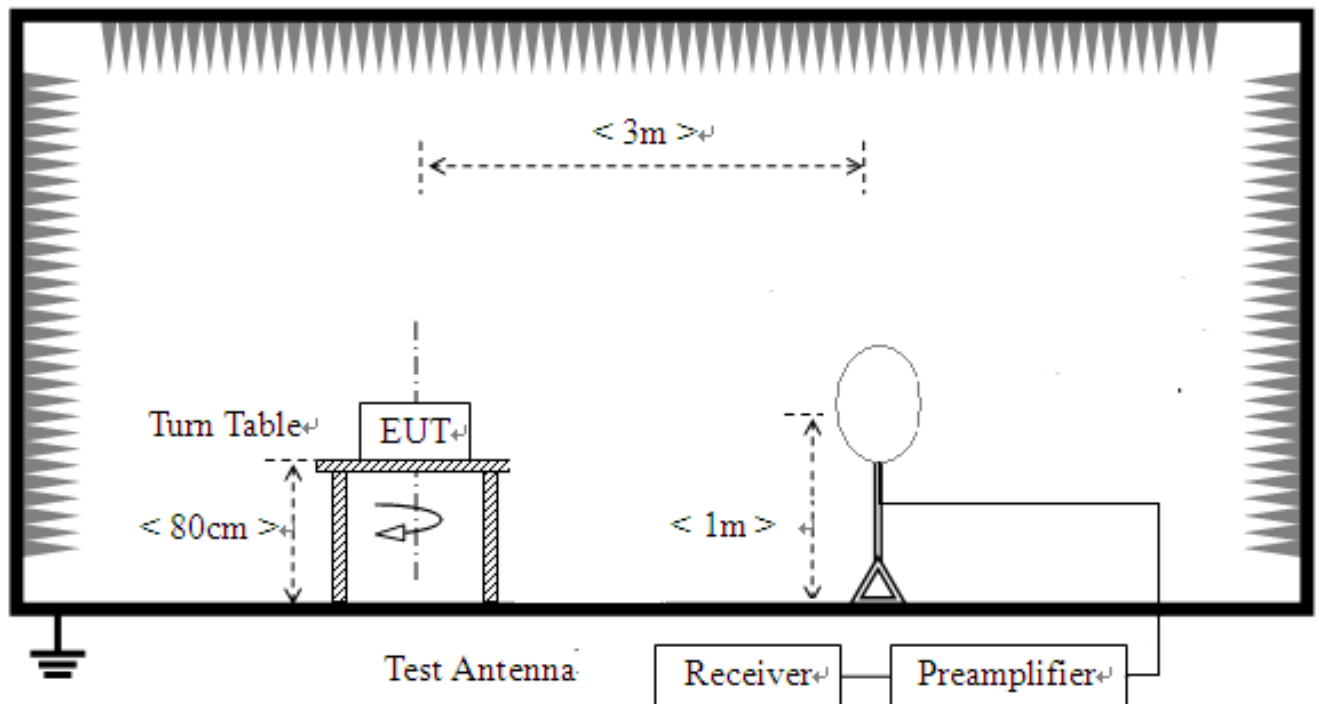

For radiated emissions from 30MHz to 1GHz

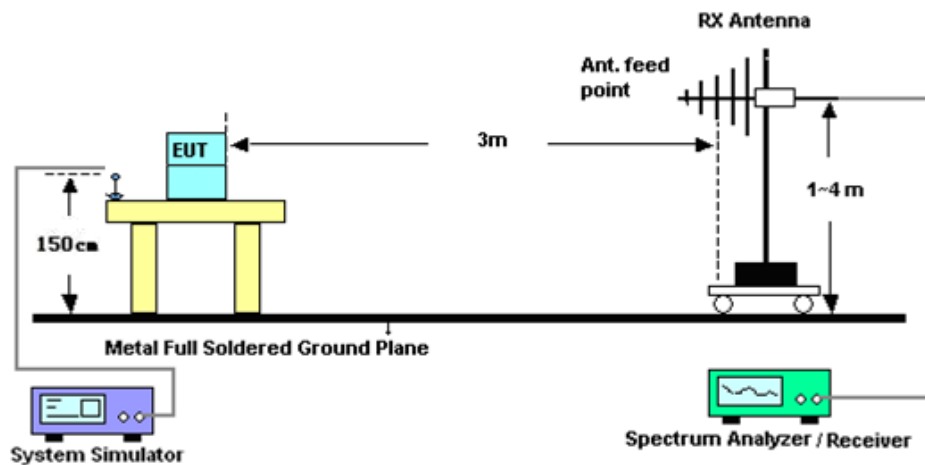

For radiated emissions above 1GHz

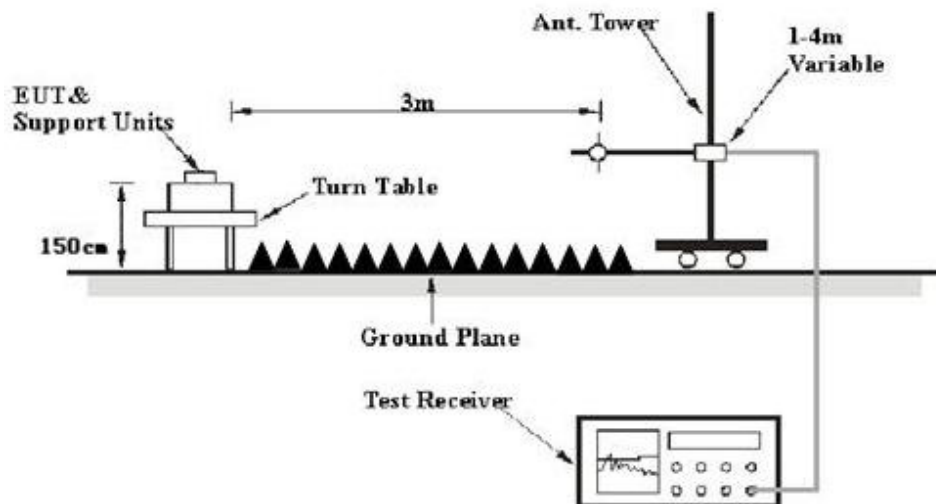

2.8.4 Test Procedures

1. The EUT was placed on a rotatable wooden table with 1.5 meter above ground.
2. The EUT was set 3 meters from the receiving antenna, which was mounted on the antenna tower.
3. The table was rotated 360 degrees and 3-orthogonal axis to determine the position of the highest spurious emission.
4. The height of the receiving antenna is varied between one meter and four meters to search the maximum spurious emission for both horizontal and vertical polarizations.

5. Make the measurement with the spectrum analyzer's RBW = 1MHz, VBW = 3MHz, taking the record the maximum spurious emission.
6. Remove the EUT and replace it with substitution antenna. A signal generator was connected to the substitution antenna by a non-radiating cable. The absolute levels of the spurious emissions were measured by the substitution.
7. A Broadband antenna (for below 1GHz) and horn antenna (for above 1GHz) was substituted in place of the EUT and was driven by a signal generator.
8. Tune the output power of signal generator to the same emission level with EUT maximum spurious emission.
9. Taking the record of output power at antenna port.
10. Repeat step 3 to step 9 for another polarization.
11. The RF fundamental frequency should be excluded against the limit line in the operating frequency band.

$$\begin{aligned} & \text{The limit line is derived from } 43 + 10\log(P)\text{dB below the transmitter power } P(\text{Watts}) \\ & = P(\text{W}) - [43 + 10\log(P)] \text{ (dB)} \\ & = [30 + 10\log(P)] \text{ (dBm)} - [43 + 10\log(P)] \text{ (dB)} \\ & = -13\text{dBm}. \end{aligned}$$

<For Band 7>

$$\begin{aligned} & \text{The limit line is derived from } 55 + 10\log(P)\text{dB below the transmitter power } P(\text{Watts}) \\ & = P(\text{W}) - [55 + 10\log(P)] \text{ (dB)} \\ & = [30 + 10\log(P)] \text{ (dBm)} - [55 + 10\log(P)] \text{ (dB)} \\ & = -25\text{dBm}. \end{aligned}$$

12. The spectrum is measured from 9 KHz to the 10th harmonic of the fundamental frequency of the transmitter using CISPR quasi peak detector below 1GHz. The worst case emissions are reported however emissions whose levels were not within 20dB of the respective limits were not reported.
13. For 9KHz to 30MHz: the amplitude of spurious emissions which are attenuated by more than 20dB below the permissible value has no need to be reported.
14. All Spurious Emission tests were performed in X, Y, Z axis direction and low, middle, high channel. And only the worst axis test condition was recorded in this test report.

2.8.5 Test Results of Radiated Spurious Emissions

Note: For 9 KHz to 30MHz: the amplitude of spurious emissions is attenuated by more than 20dB below the permissible value, so we not provide the test result here.

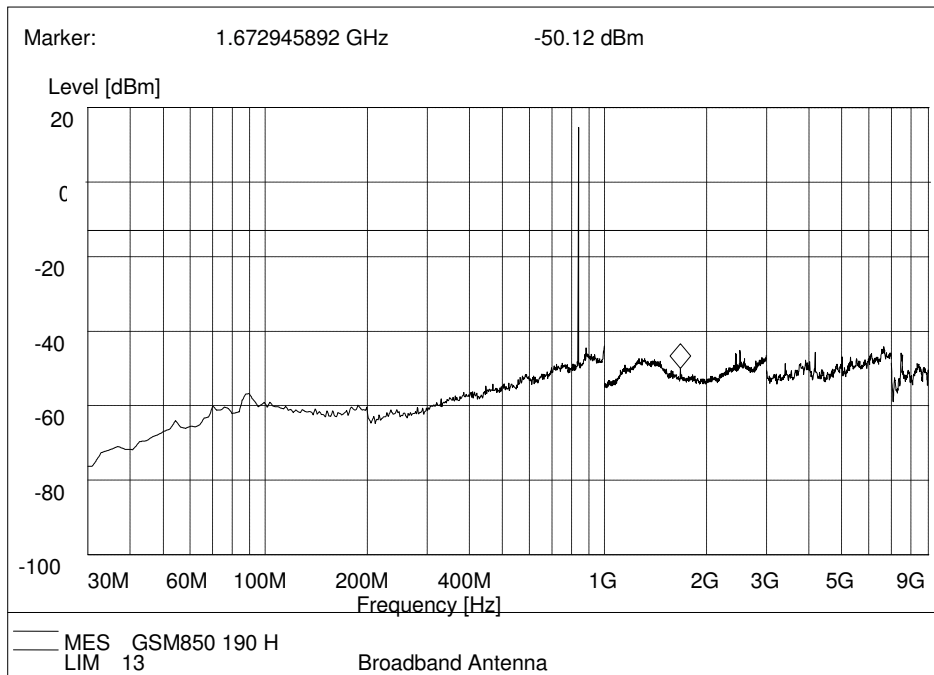

GPRS 850MHz, Test Antenna Horizontal

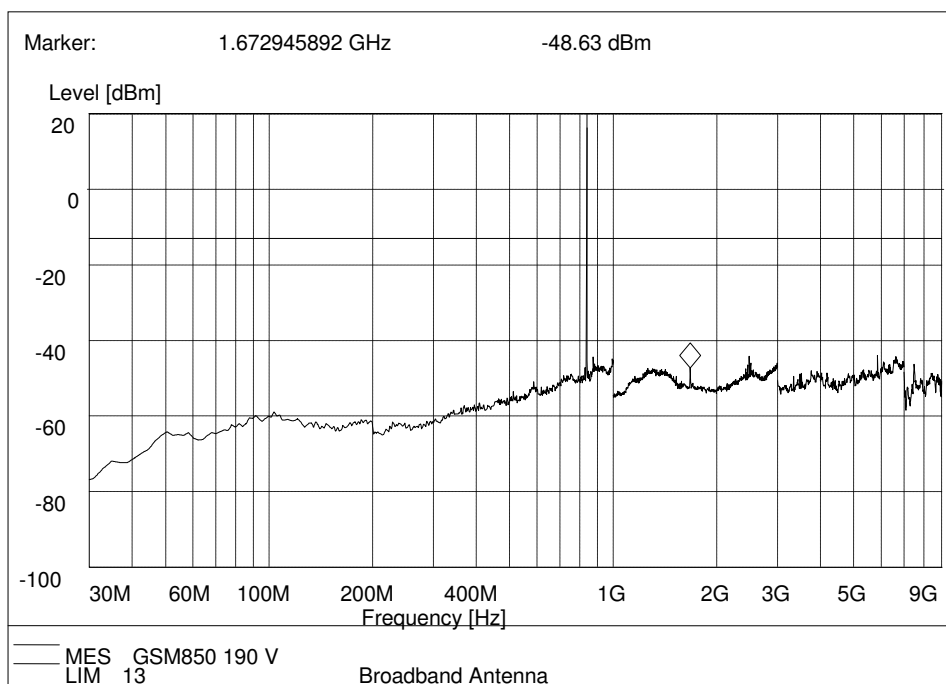

GPRS 850MHz, Test Antenna Vertical

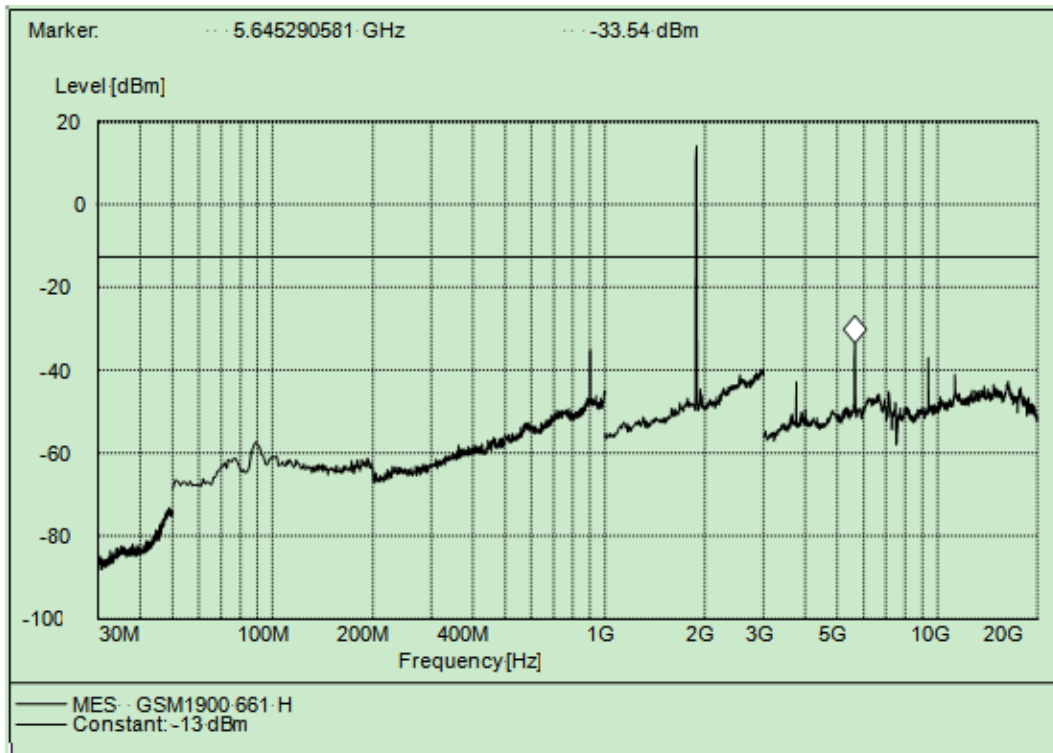

GPRS 1900MHz, Test Antenna Horizontal

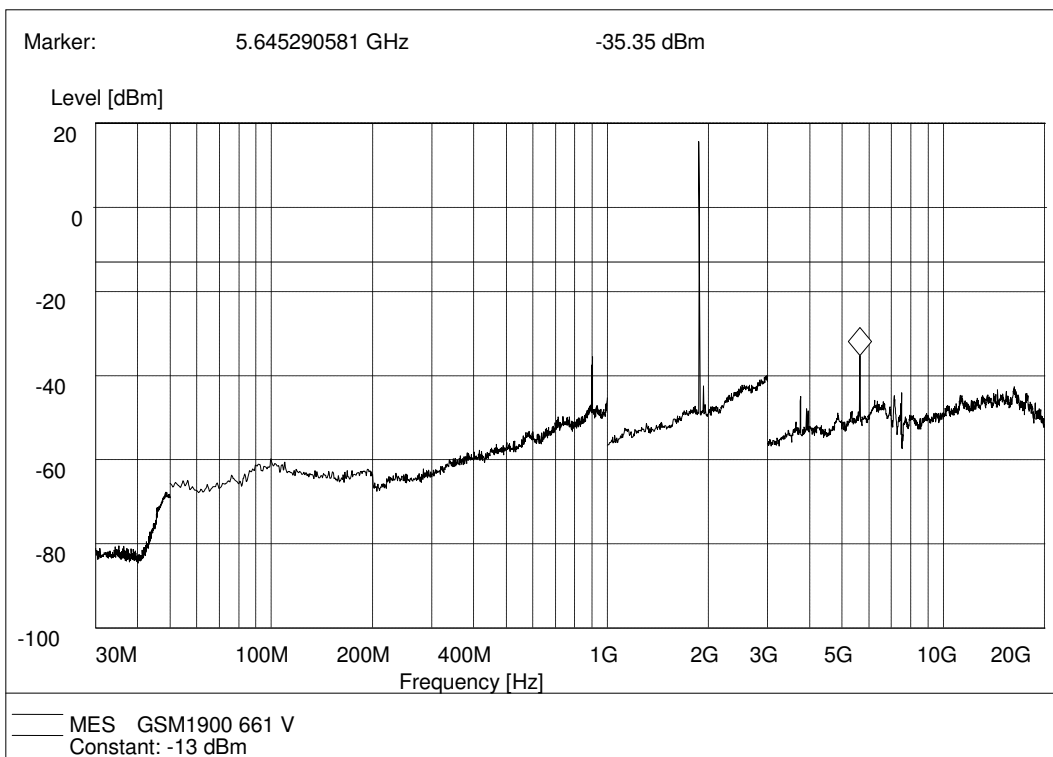

GPRS 1900MHz, Test Antenna Vertical



3. LIST OF MEASURING EQUIPMENT

Description	Manufacturer	Model	Serial No.	Test Date	Due Date	Remark
EMI Test Receiver	R&S	ESIB26	A0304218	2015.06.02	2016.06.01	Radiation
Full-Anechoic Chamber	Albatross	12.8m*6.8m*6.4m	A0412372	2015.06.02	2016.06.01	Radiation
Loop Antenna	Schwarz beck	HFH2-Z2	100047	2015.06.02	2016.06.01	Radiation
Bilog Antenna	Schwarzbeck	VULB 9163	9163-274	2015.06.02	2016.06.01	Radiation
Broadband antenna (30MHz~1GHz)	R&S	HL562	101341	2015.06.02	2016.06.01	Radiation
Broadband antenna (30MHz~1GHz)	R&S	HL562	101339	2015.06.02	2016.06.01	Radiation
Double ridge horn antenna (1GHz~18GHz)	R&S	HF906	100150	2015.06.02	2016.06.01	Radiation
Double ridge horn antenna (1GHz~18GHz)	R&S	HF906	100148	2015.06.02	2016.06.01	Radiation
Horn antenna (18GHz~26.5GHz)	R&S	HM118	101286	2015.06.02	2016.06.01	Radiation
Horn antenna (18GHz~26.5GHz)	R&S	HM118	101284	2015.06.02	2016.06.01	Radiation
Amplifier 20M~3GHz	R&S	PAP-0203H	22018	2015.06.02	2016.06.01	Radiation
Ampilier 1G~18GHz	R&S	MITEQ AFS42-00101800	25-S-42	2015.06.02	2016.06.01	Radiation
Ampilier 18G~40GHz	R&S	JS42-18002600-28-5A	12111.0980.00	2015.06.02	2016.06.01	Radiation
Spectrum Analyzer	R&S	FSP40	1164.4391.40	2015.07.07	2016.07.06	Conducted
Power Meter	R&S	NRP2	1020.1809.02	2015.06.02	2016.06.01	Conducted
Power Sensor	R&S	NRP-Z81	823.3618.03	2015.06.02	2016.06.01	Conducted
LISN	ROHDE&SCHWARZ	ESH2-Z5	A0304221	2015.06.02	2016.06.01	Conducted
Test Receiver	R&S	ESCS30	A0304260	2015.06.02	2016.06.01	Conducted
Cable	SUNHNER	SUCOFLEX 100	/	2015.06.02	2016.06.01	Radiation
Cable	SUNHNER	SUCOFLEX 104	/	2015.06.02	2016.06.01	Radiation



4. UNCERTAINTY OF EVALUATION

Where relevant, the following measurement uncertainty levels have been estimated for tests performed on the EUT as specified in CISPR 16-4-2

Measurement	Frequency	Uncertainty
Conducted emissions	9kHz~30MHz	2.35dB
Radiated emissions	9kHz~30MHz	2.59dB
	30MHz~1000MHz	2.45dB
	1G~18GHz	2.21dB
	18G~40GHz	1.96dB

This uncertainty represents an expanded uncertainty expressed at approximately the 95% confidence level using a coverage factor of $k=2$.

**** END OF REPORT ****